



(19) **United States**

(12) **Patent Application Publication**
SINELNIKOV et al.

(10) **Pub. No.: US 2016/0374710 A1**

(43) **Pub. Date: Dec. 29, 2016**

(54) **CAROTID BODY ABLATION WITH A
TRANSVENOUS ULTRASOUND IMAGING
AND ABLATION CATHETER**

(22) Filed: **Sep. 12, 2016**

Related U.S. Application Data

(71) Applicants: **Yegor D. SINELNIKOV**, Port Jefferson, NY (US); **Zoar Jacob ENGELMAN**, Salt Lake City, UT (US); **Mark GELFAND**, New York, NY (US); **Martin M. GRASSE**, San Francisco, CA (US); **Timothy A. KOSS**, Discovery Bay, CA (US); **Michael Brick MARKHAM**, Redwood City, CA (US); **Kenneth M. MARTIN**, Woodside, CA (US); **Veijo T. SUORSA**, Sunnyvale, CA (US); **Miriam H. TAIMISTO**, San Jose, CA (US); **Xian WEI**, Mountain View, CA (US); **Brice Arnault DE LA MENARDIERE**, Santa Cruz, CA (US); **Clayton Miles BALDWIN**, Santa Cruz, CA (US); **Jason MILLER**, Los Altos, CA (US)

(63) Continuation-in-part of application No. 15/069,531, filed on Mar. 14, 2016, which is a continuation-in-part of application No. 14/656,635, filed on Mar. 12, 2015.
(60) Provisional application No. 62/132,459, filed on Mar. 12, 2015, provisional application No. 61/952,015, filed on Mar. 12, 2014, provisional application No. 62/017,148, filed on Jun. 25, 2014, provisional application No. 62/049,980, filed on Sep. 12, 2014, provisional application No. 62/217,570, filed on Sep. 11, 2015, provisional application No. 62/219,595, filed on Sep. 16, 2015.

Publication Classification

(72) Inventors: **Yegor D. SINELNIKOV**, Port Jefferson, NY (US); **Zoar Jacob ENGELMAN**, Salt Lake City, UT (US); **Mark GELFAND**, New York, NY (US); **Martin M. GRASSE**, San Francisco, CA (US); **Timothy A. KOSS**, Discovery Bay, CA (US); **Michael Brick MARKHAM**, Redwood City, CA (US); **Kenneth M. MARTIN**, Woodside, CA (US); **Veijo T. SUORSA**, Sunnyvale, CA (US); **Miriam H. TAIMISTO**, San Jose, CA (US); **Xian WEI**, Mountain View, CA (US); **Brice Arnault DE LA MENARDIERE**, Santa Cruz, CA (US); **Clayton Miles BALDWIN**, Santa Cruz, CA (US); **Jason MILLER**, Los Altos, CA (US)

(51) **Int. Cl.**
A61B 17/32 (2006.01)
A61B 17/3207 (2006.01)
A61B 8/08 (2006.01)
A61B 8/12 (2006.01)
A61B 8/00 (2006.01)
(52) **U.S. Cl.**
CPC *A61B 17/320068* (2013.01); *A61B 8/12* (2013.01); *A61B 8/445* (2013.01); *A61B 8/481* (2013.01); *A61B 17/3207* (2013.01); *A61B 2017/0023* (2013.01)

(21) Appl. No.: **15/263,174**

(57) **ABSTRACT**

Methods and devices for assessing, and treating patients having sympathetically mediated disease, involving augmented peripheral chemoreflex and heightened sympathetic tone by reducing chemosensor input to the nervous system via carotid body ablation. The methods may be performed using an ultrasound ablation catheter. The methods may also include imaging using at least one ultrasound imaging catheter.

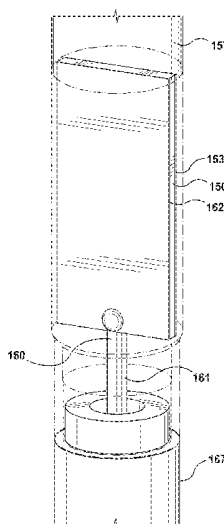

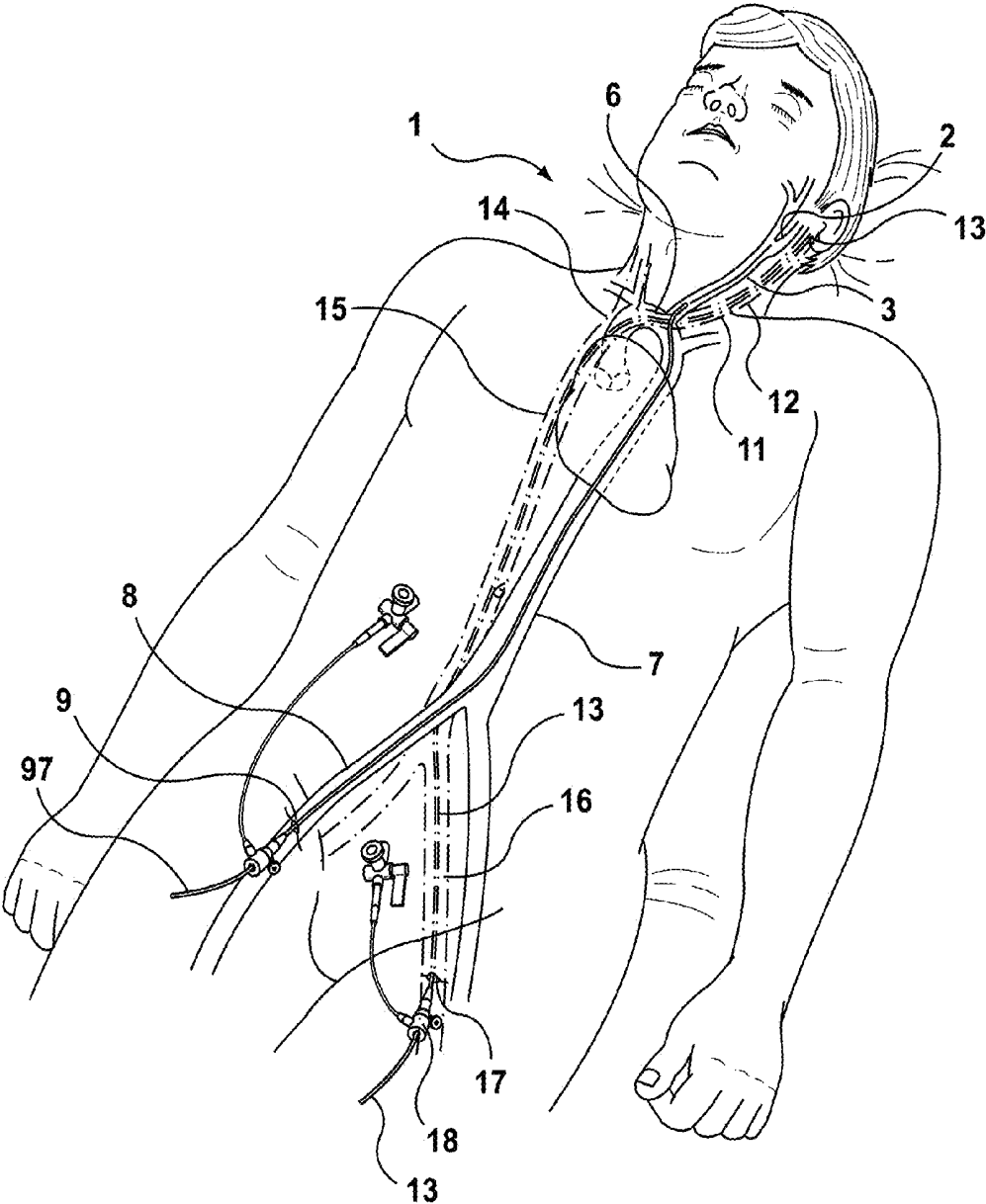

FIG. 1

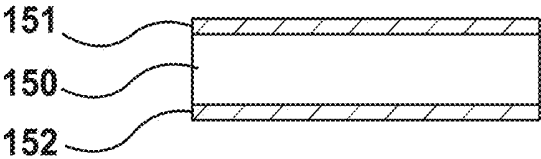

FIG. 3A

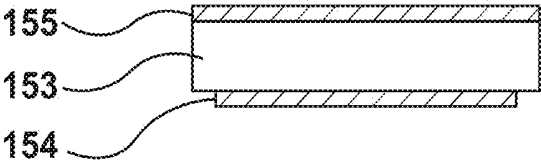

FIG. 3B

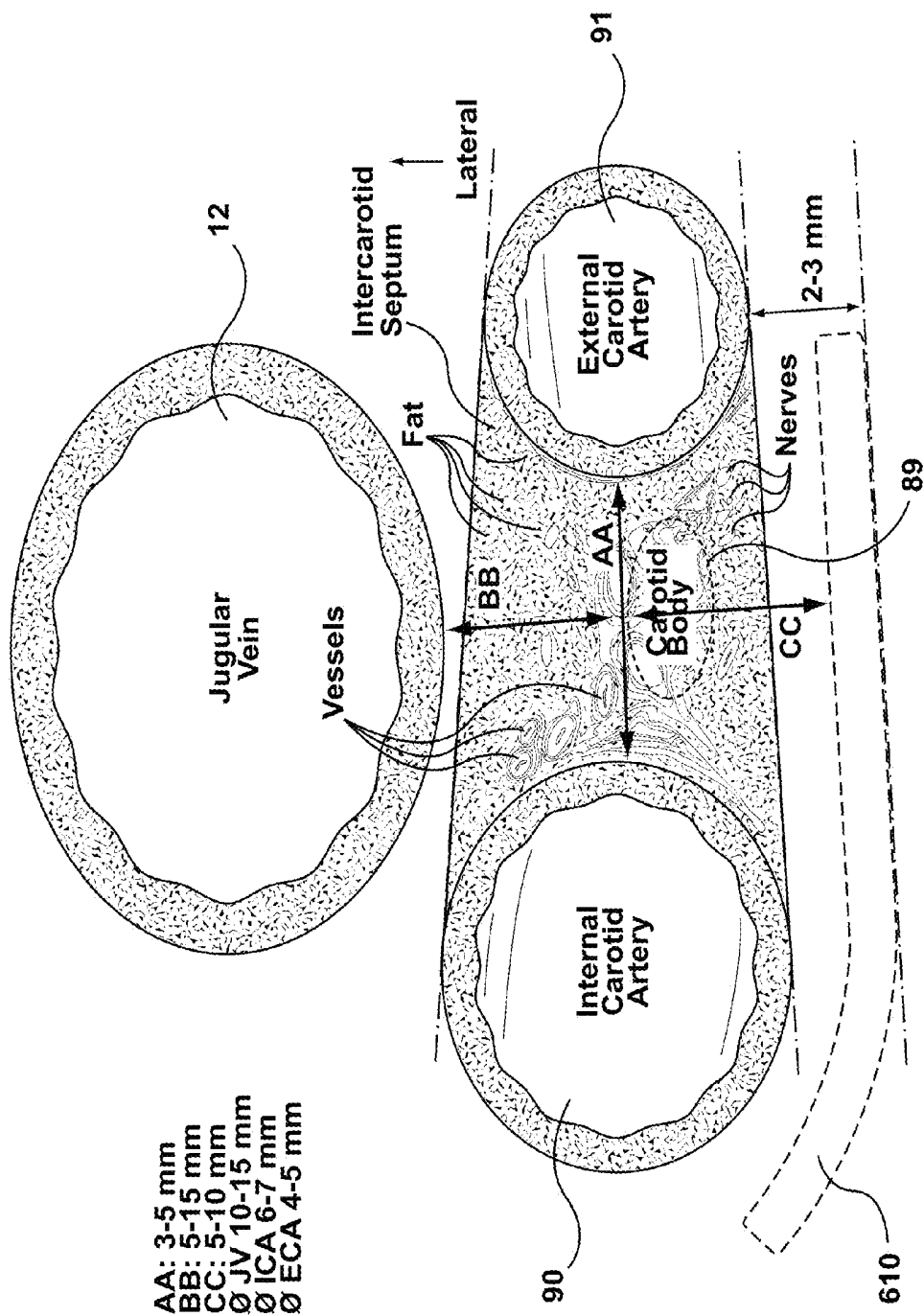

FIG. 2

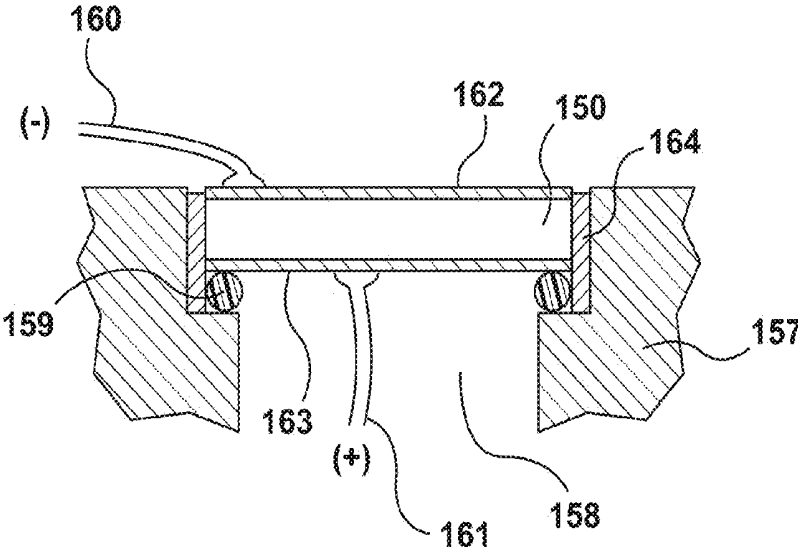

FIG. 3C

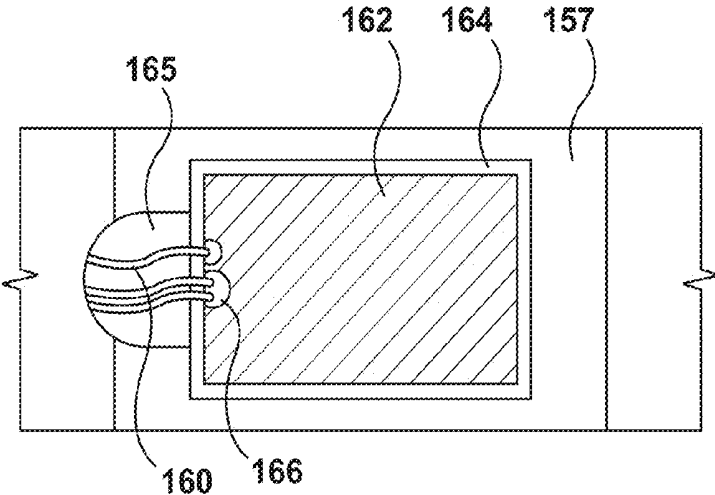

FIG. 3D

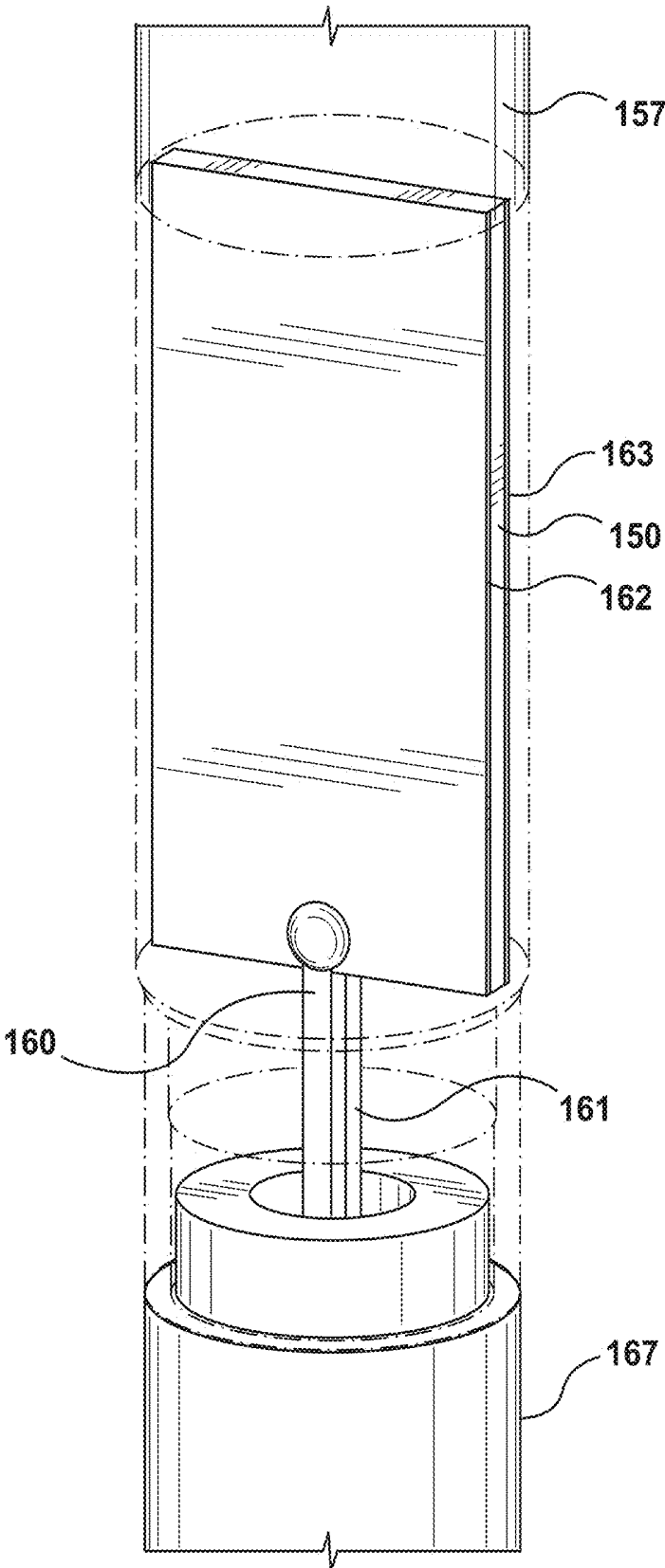

FIG. 3E

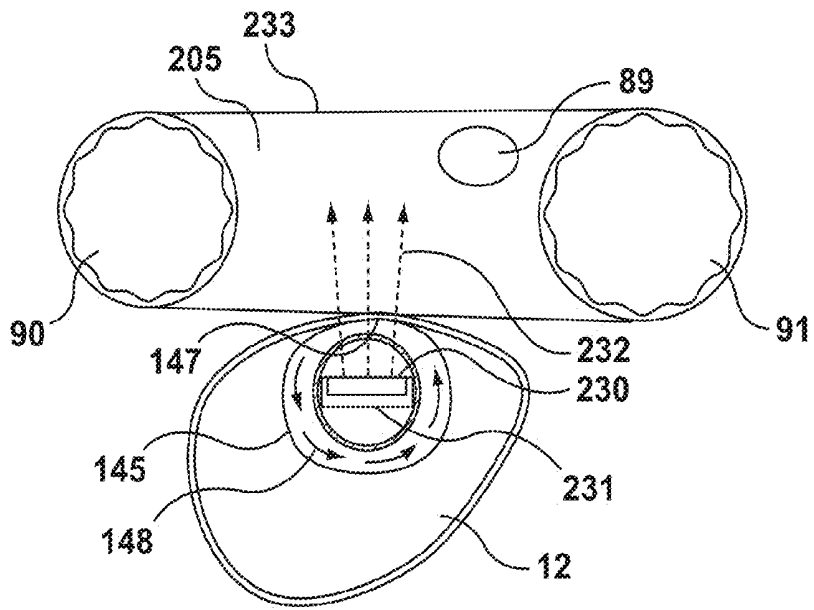

FIG. 4A

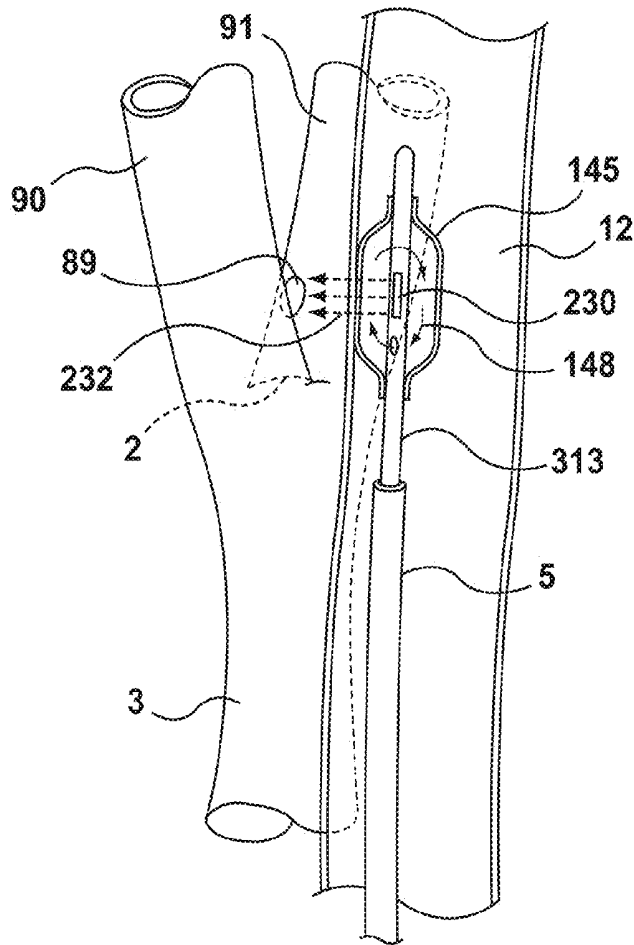

FIG. 4B

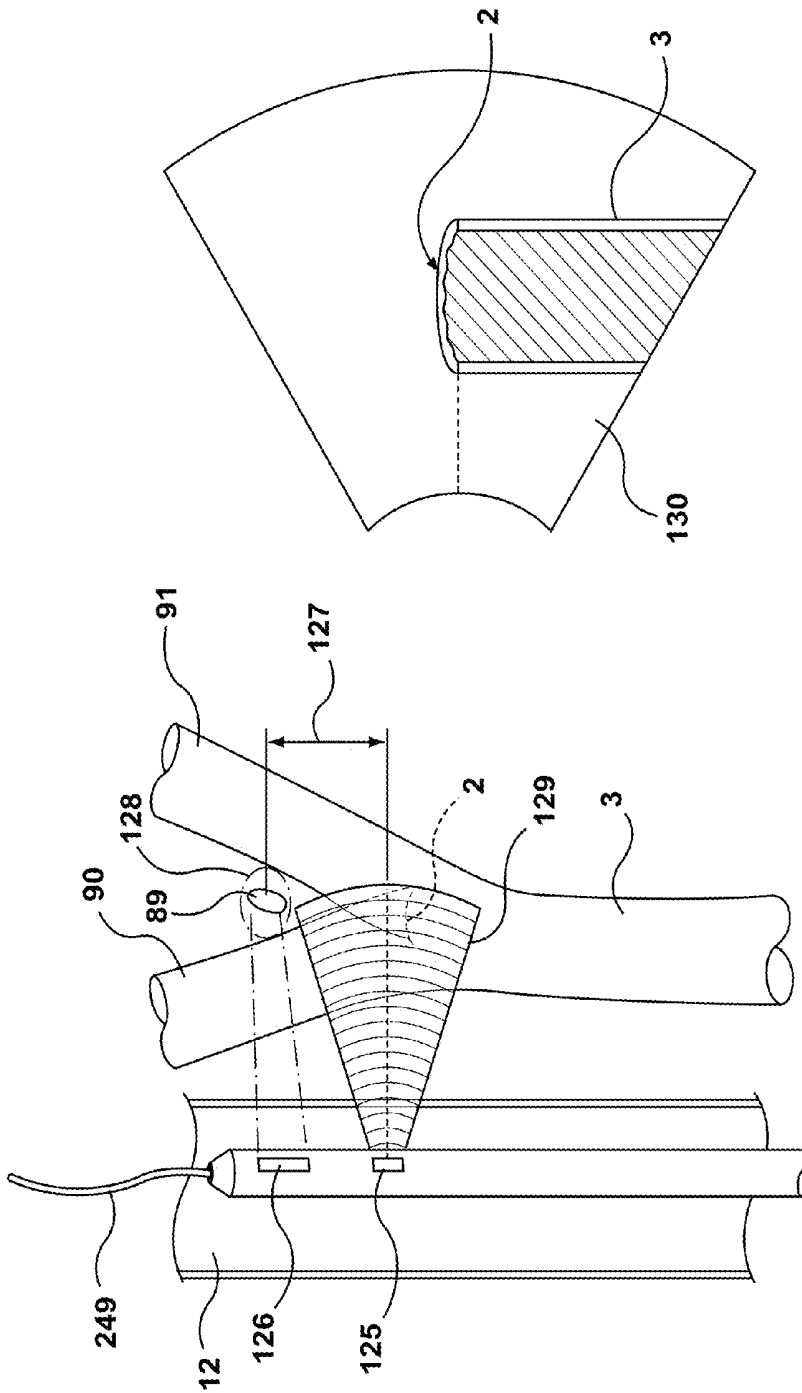

FIG. 5B

FIG. 5A

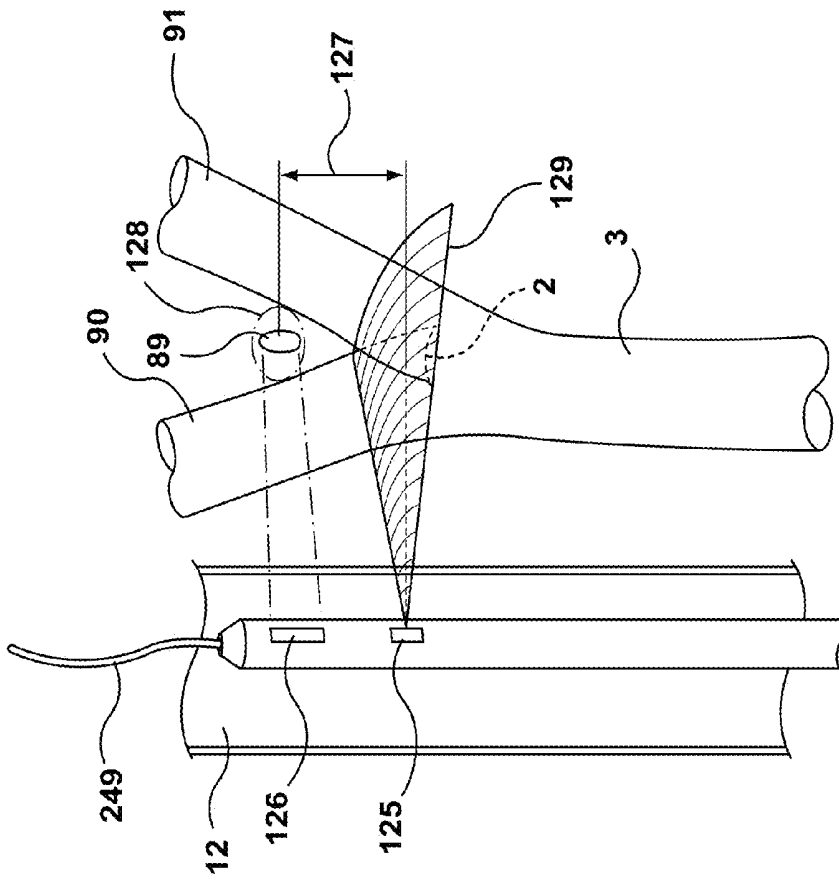

FIG. 6A

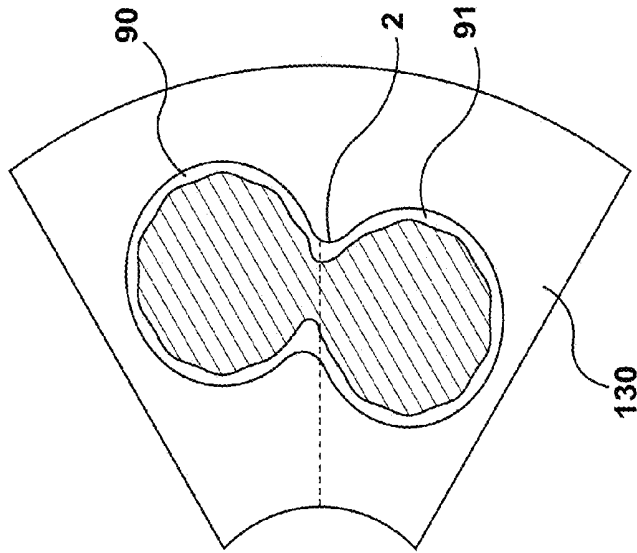

FIG. 6B

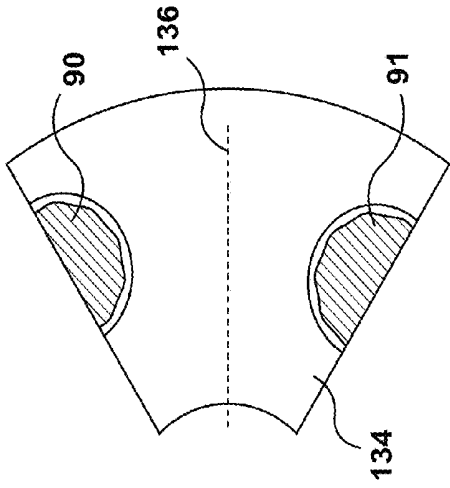

FIG. 7B

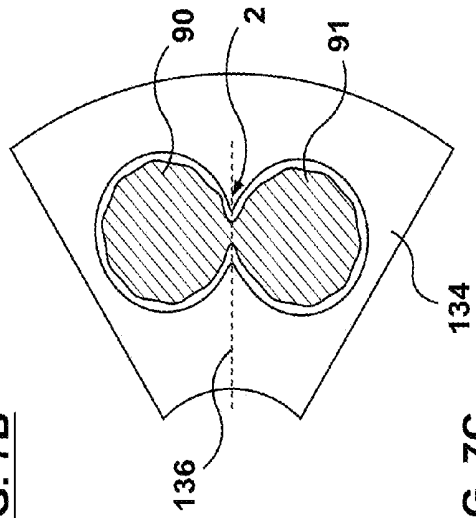

FIG. 7C

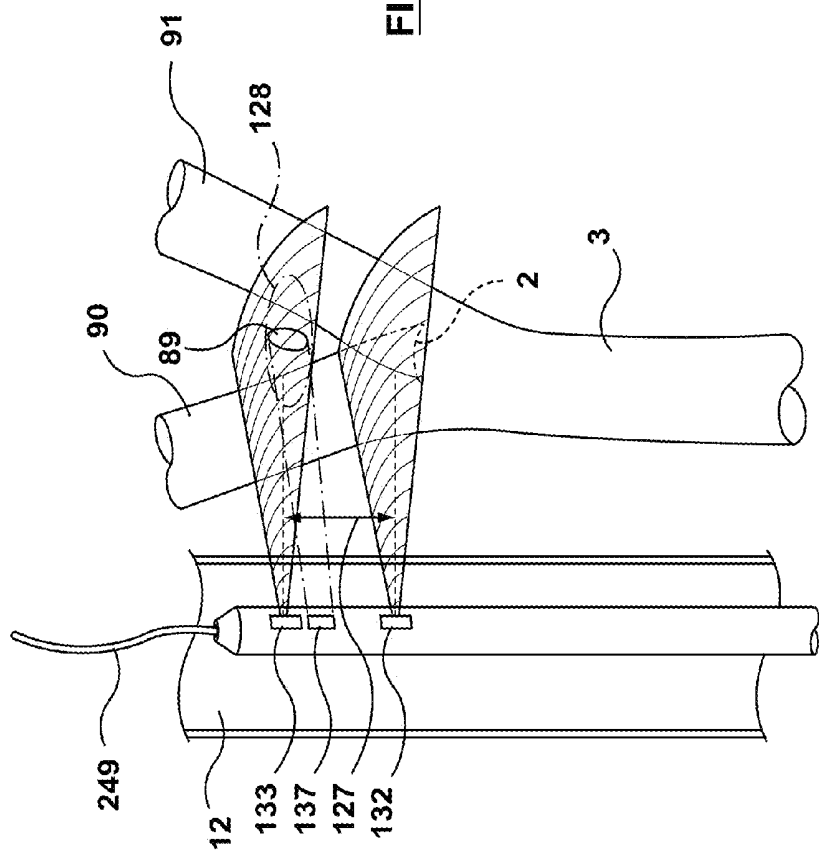

FIG. 7A

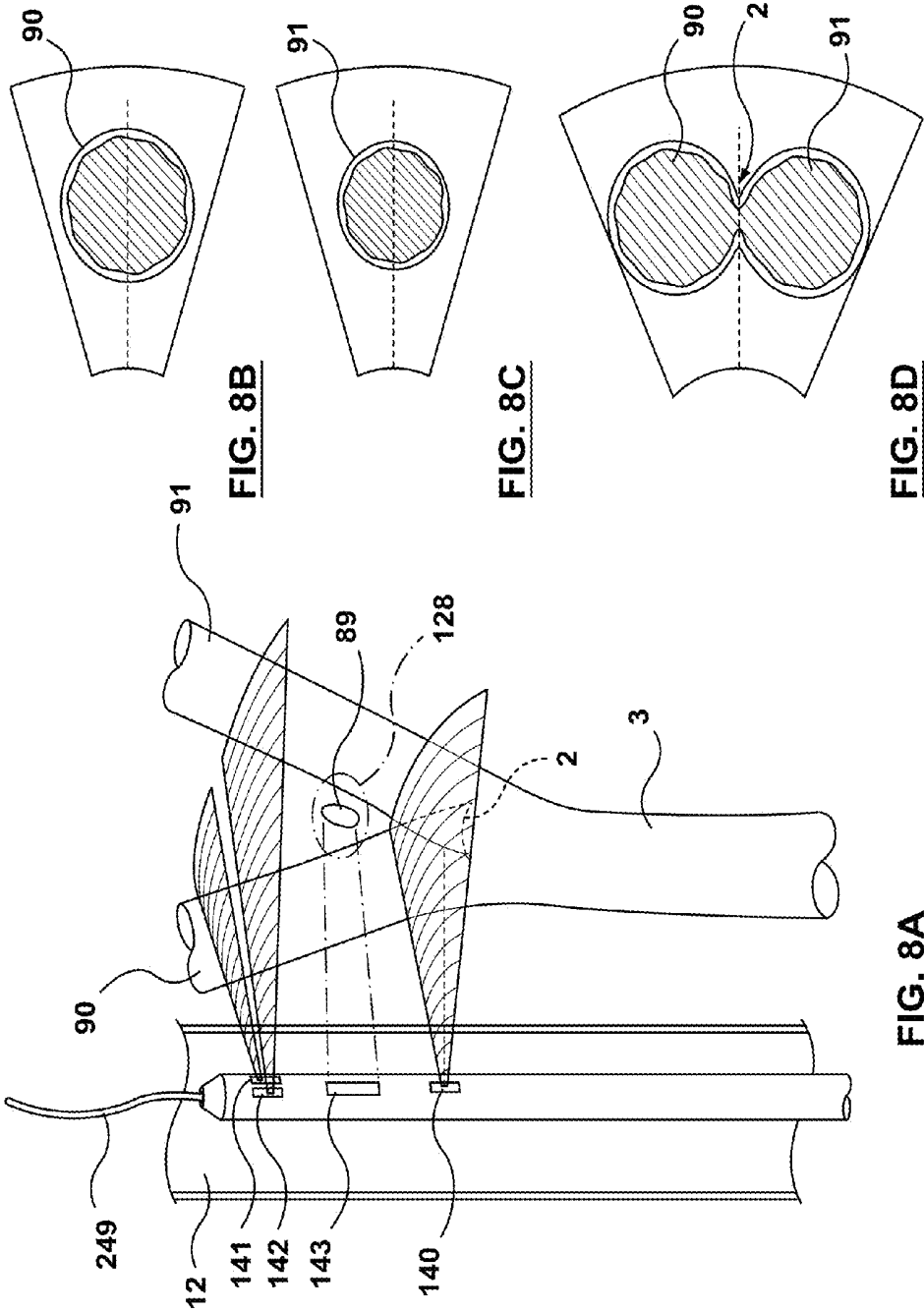

FIG. 8B

FIG. 8C

FIG. 8D

FIG. 8A

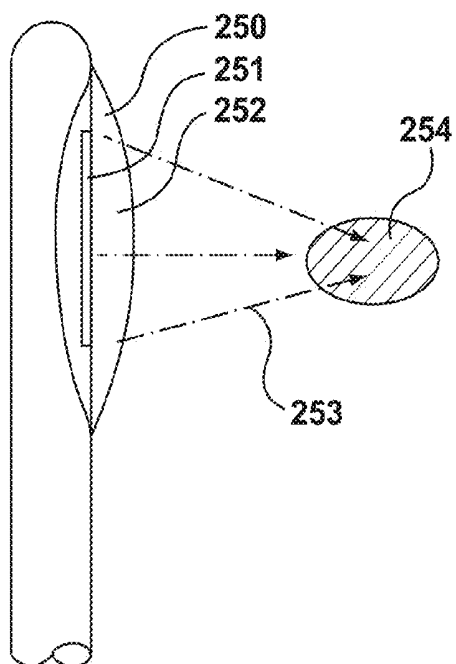

FIG. 9A

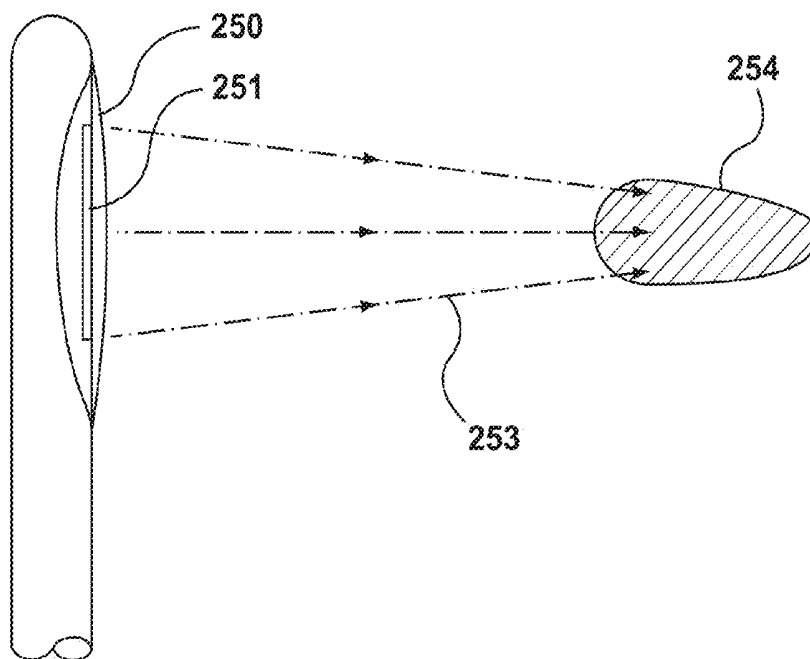

FIG. 9B

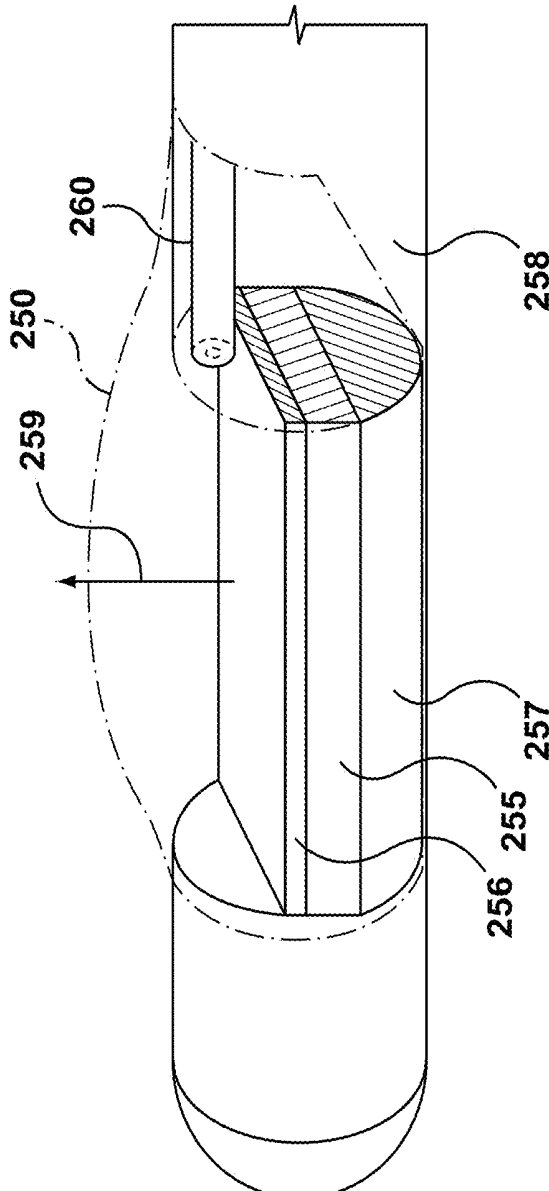

FIG. 10

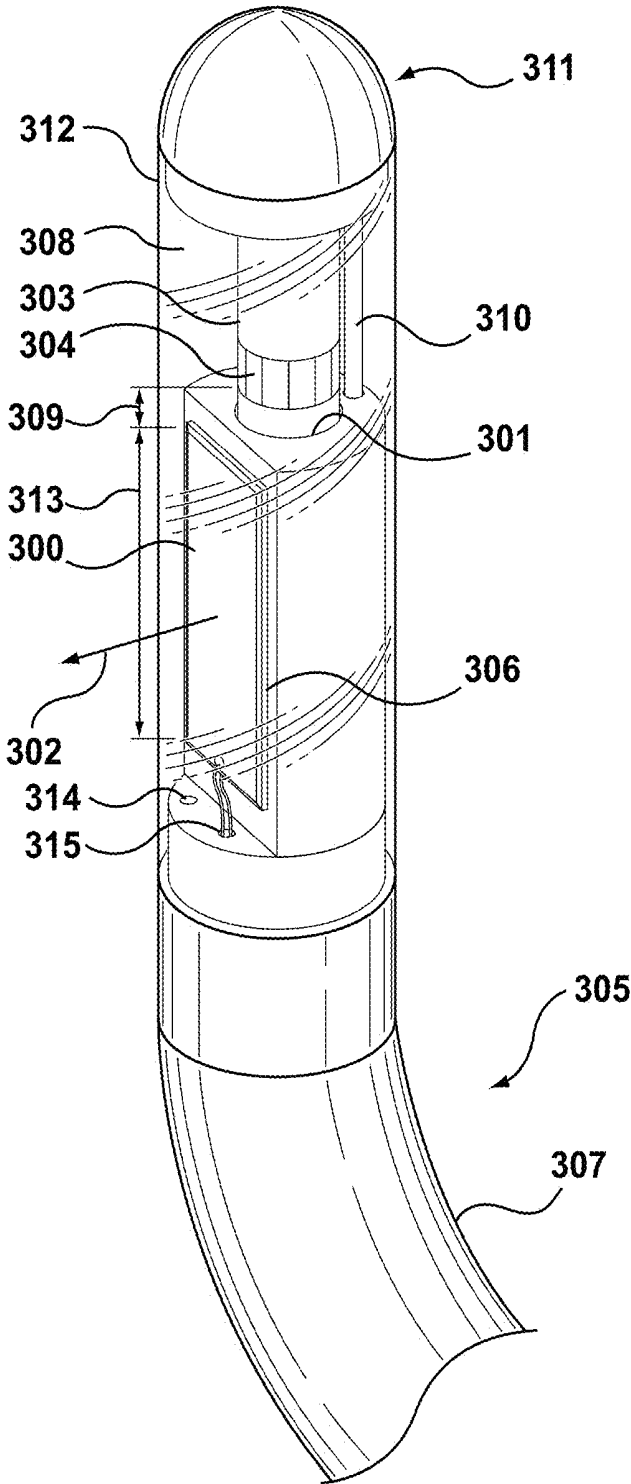

FIG. 11

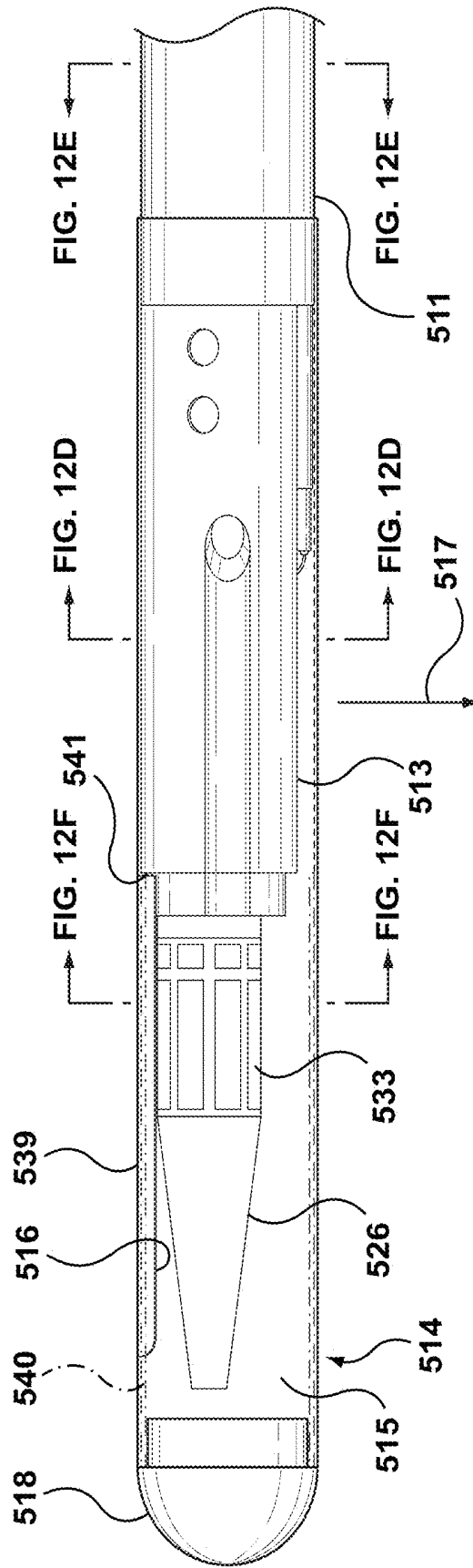

FIG. 12A

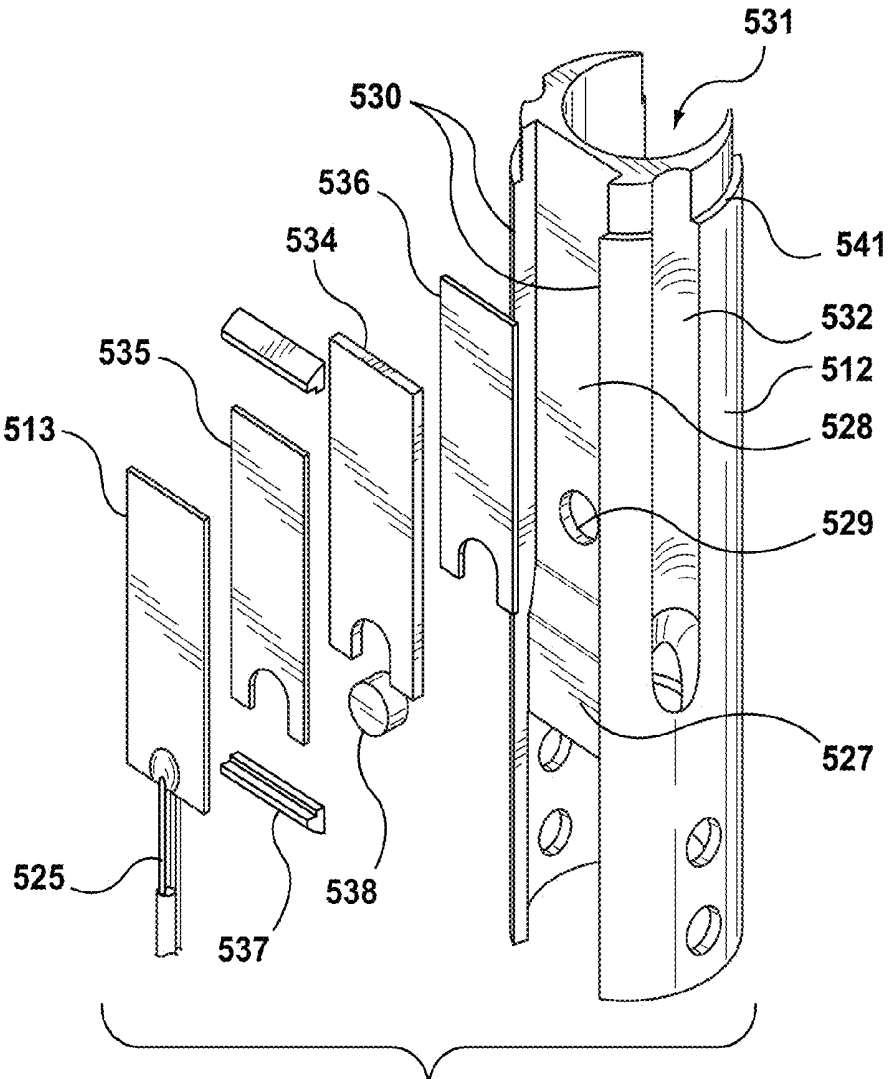

FIG. 12B

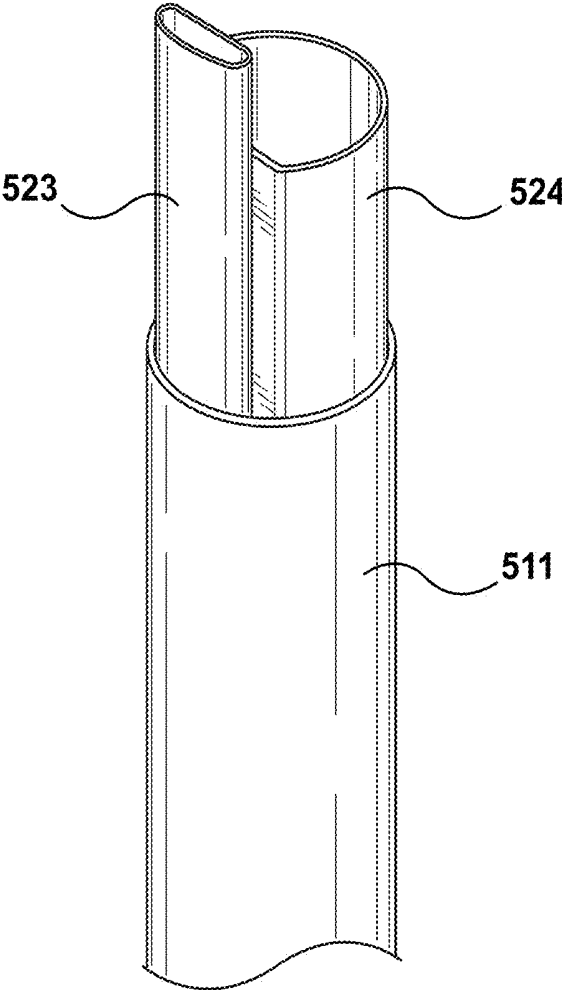

FIG. 12C

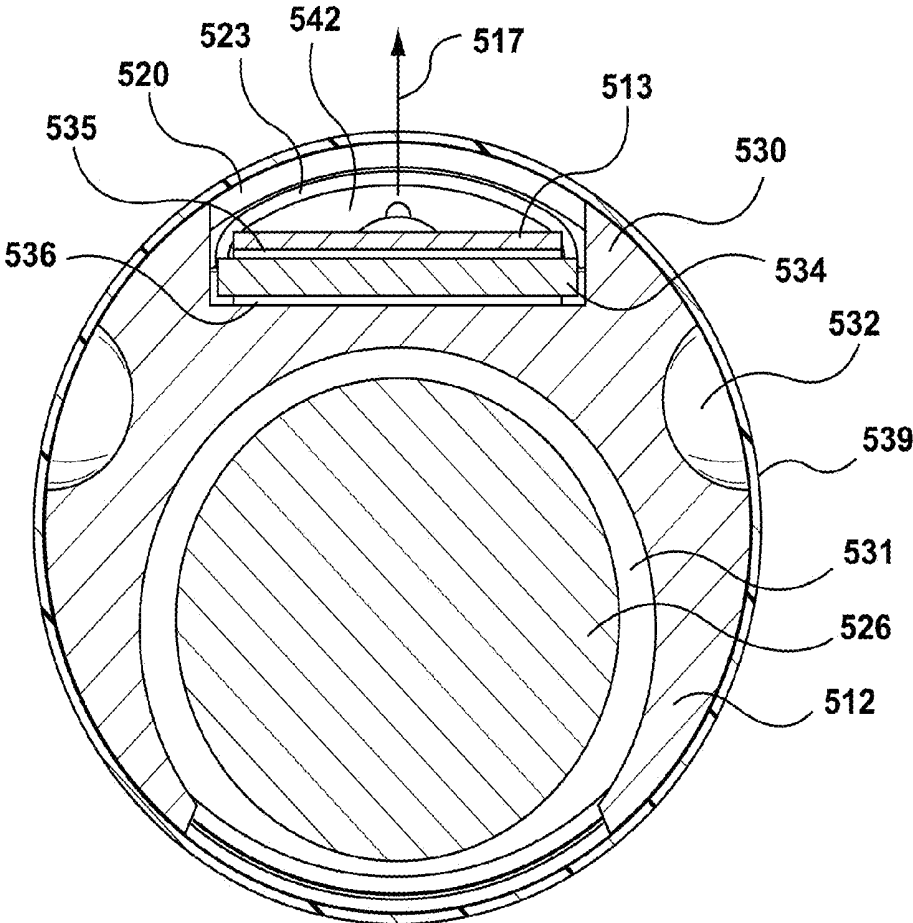

FIG. 12D

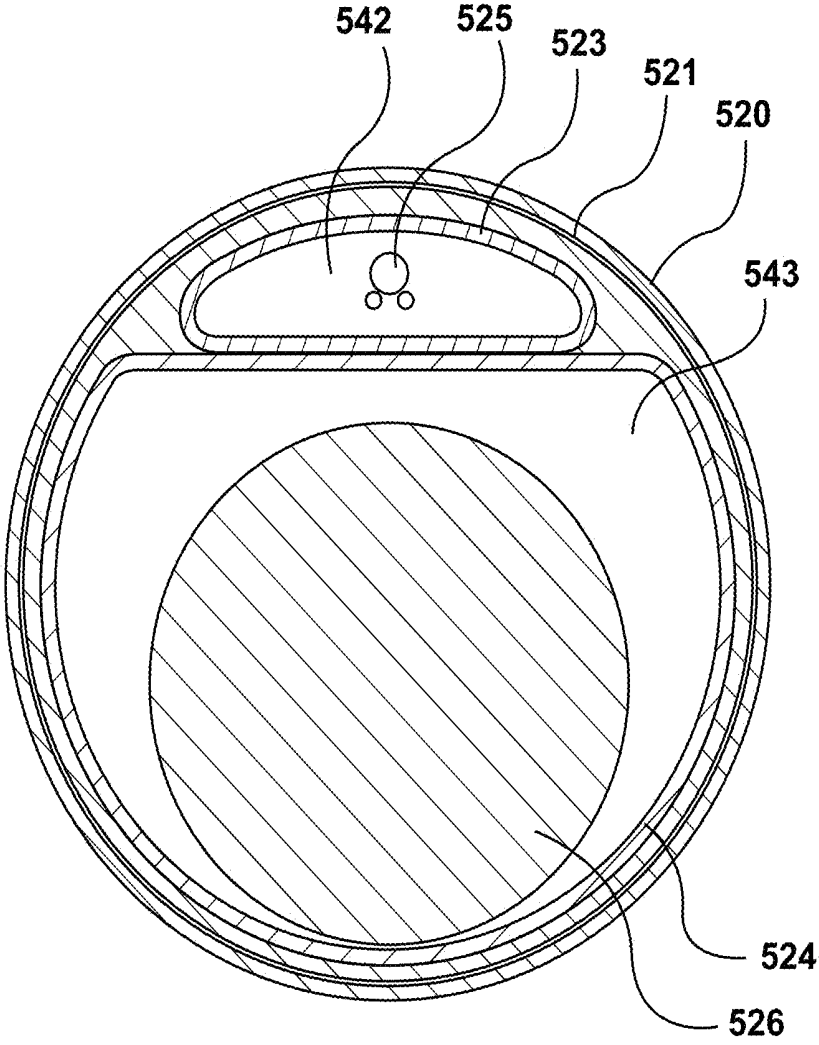

FIG. 12E

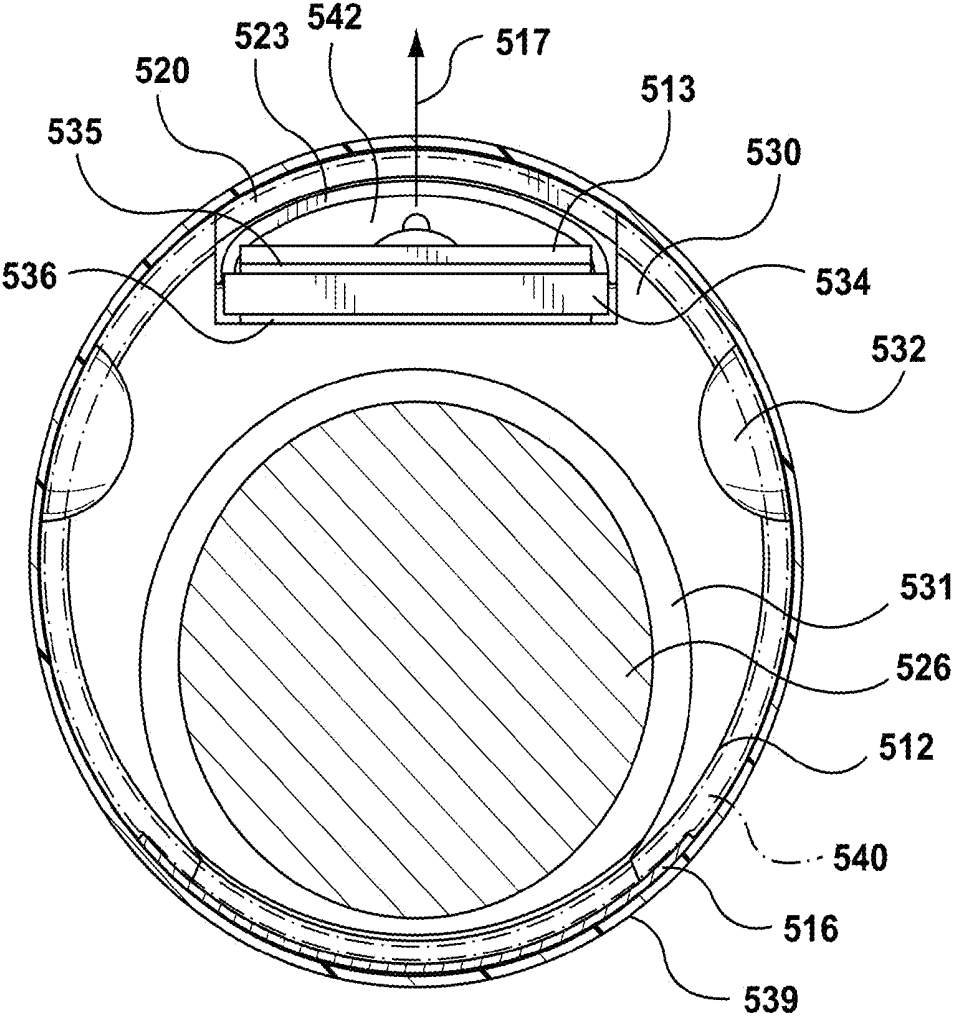

FIG. 12F

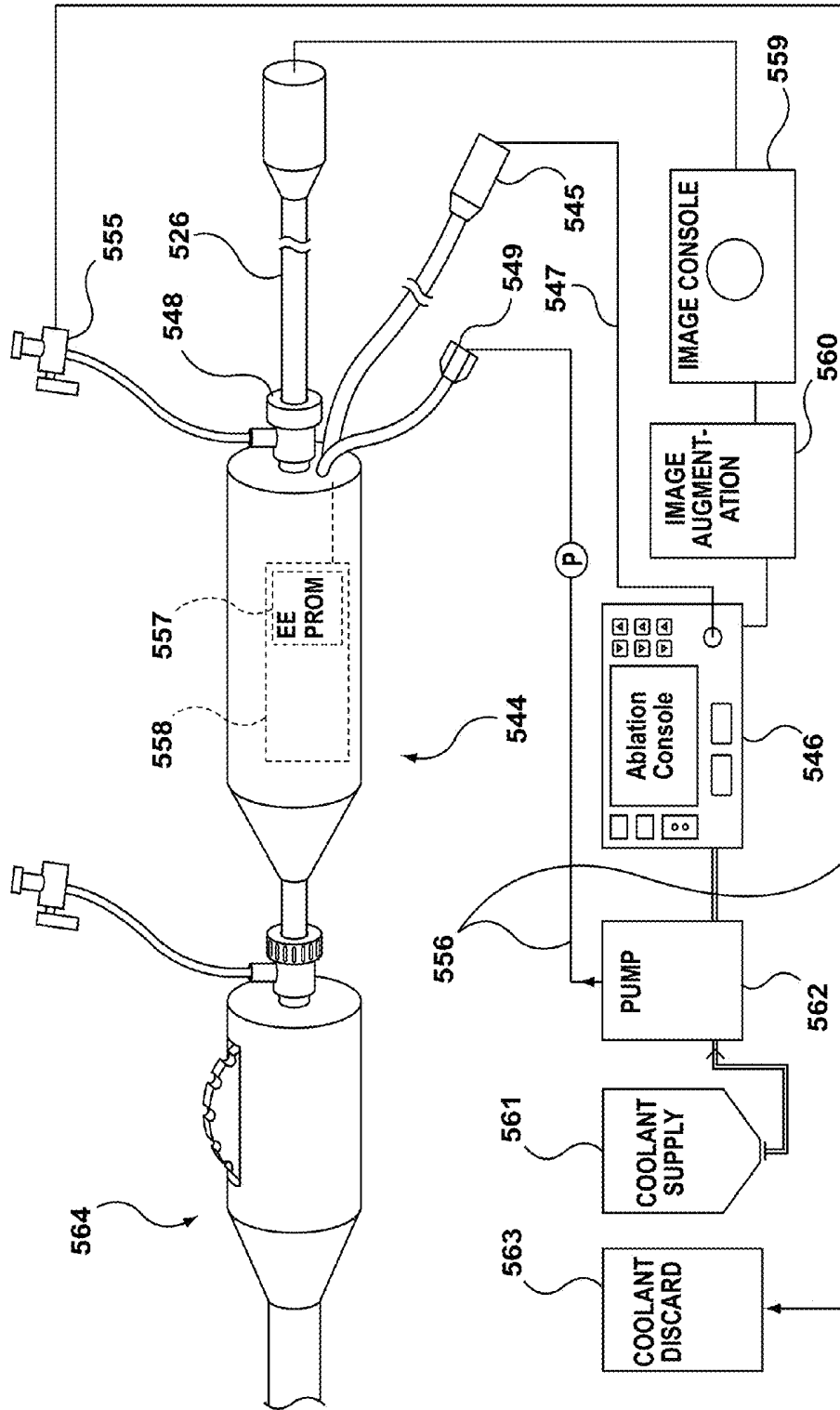

FIG. 12G

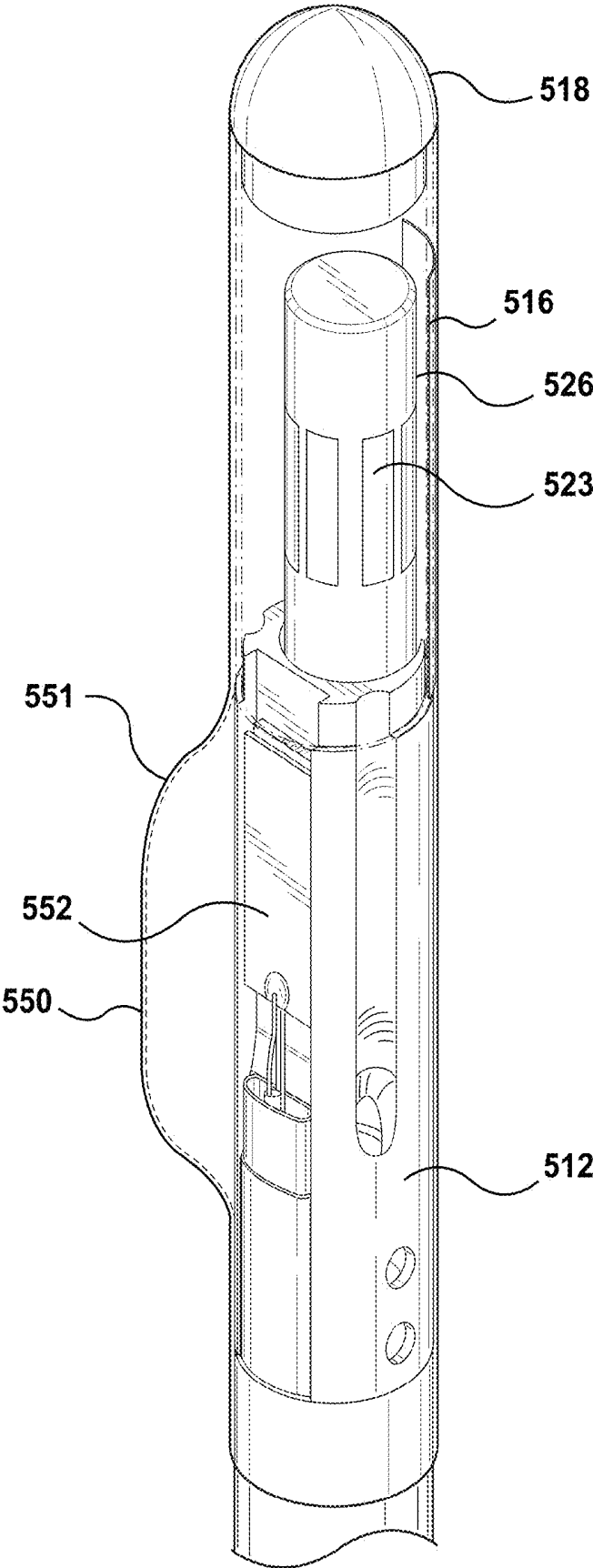

FIG. 12H

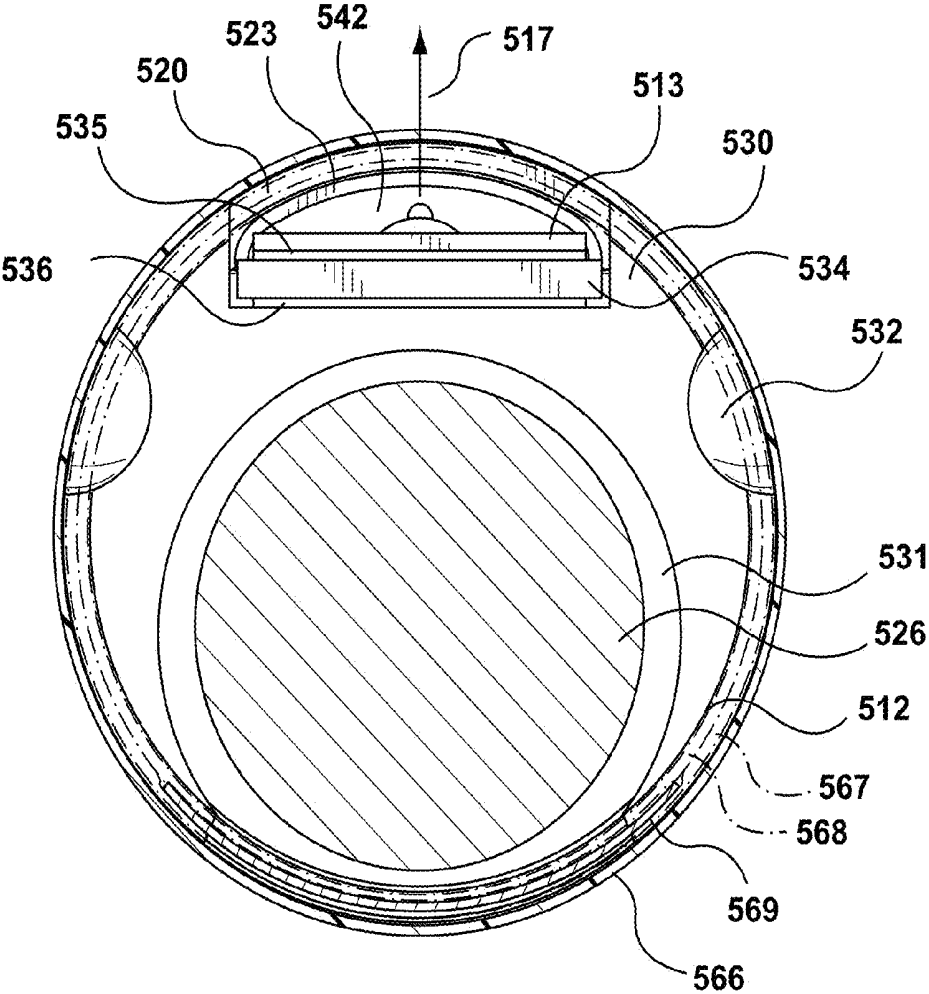

FIG. 12I

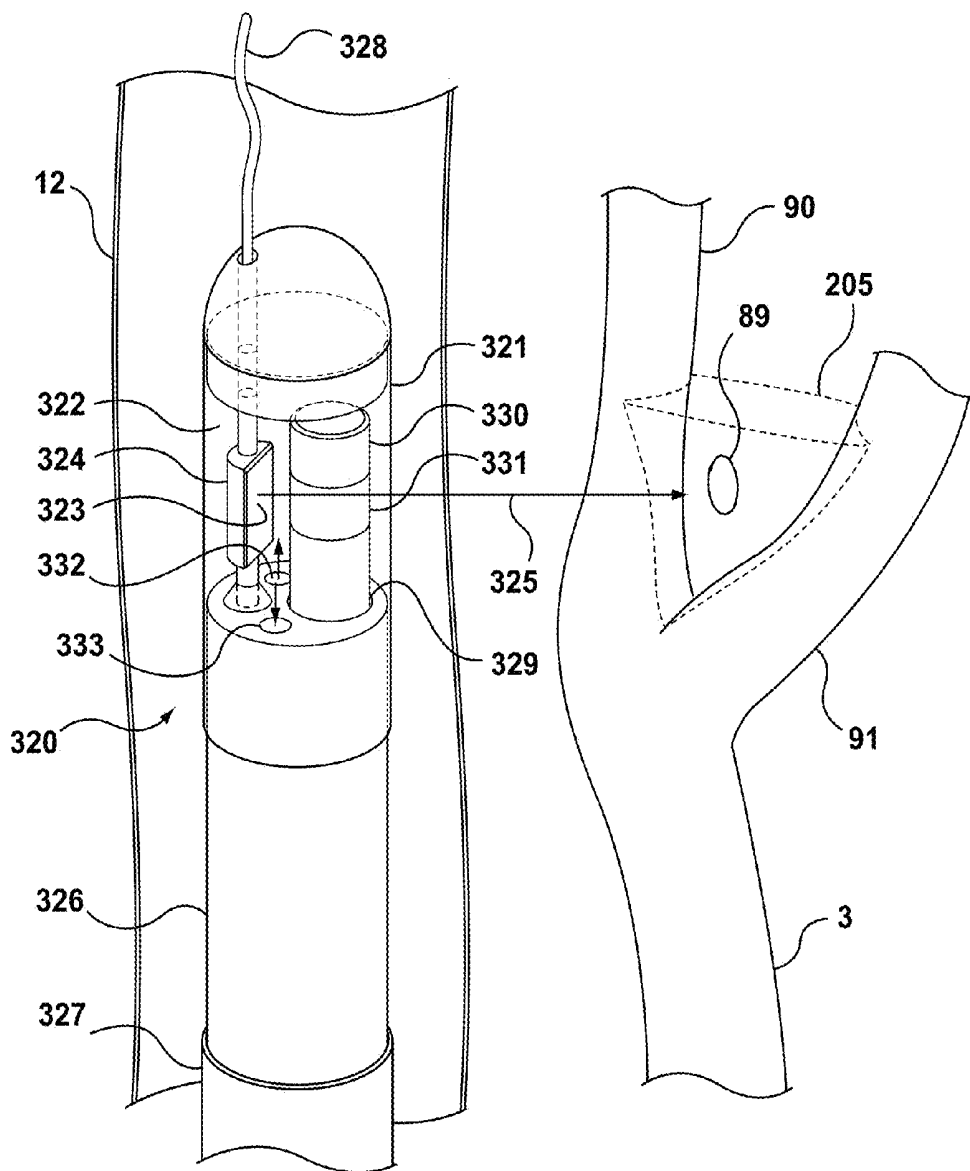

FIG. 13

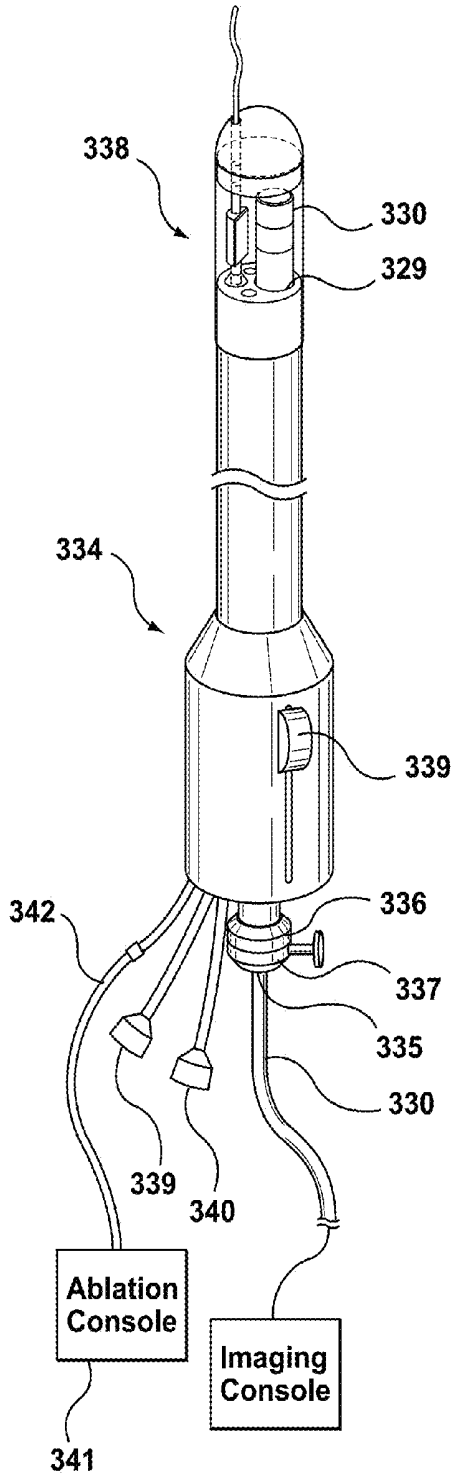

FIG. 14A

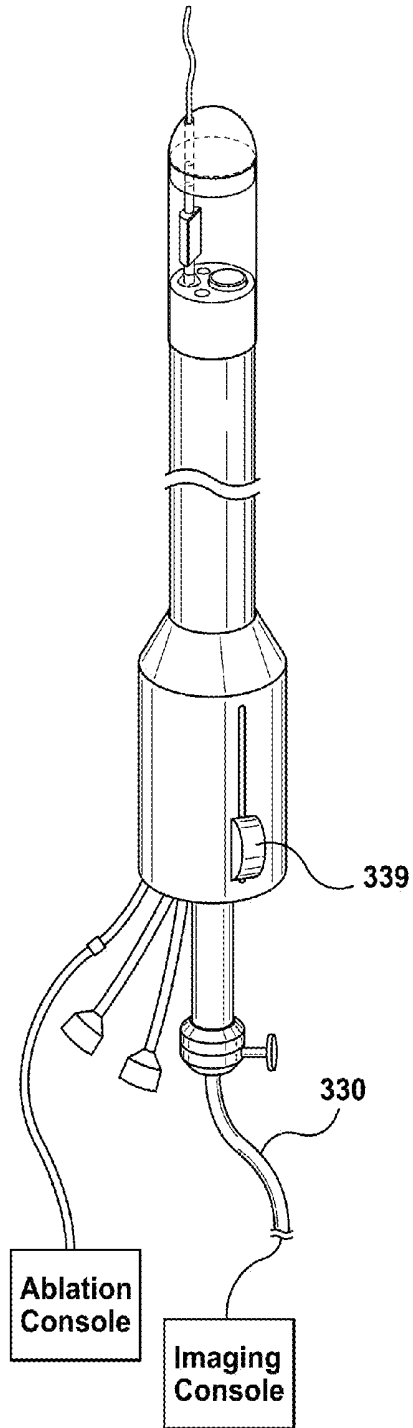

FIG. 14B

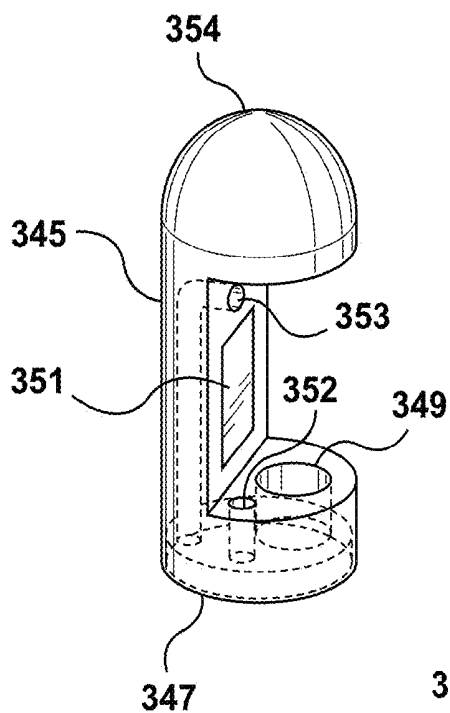

FIG. 15A

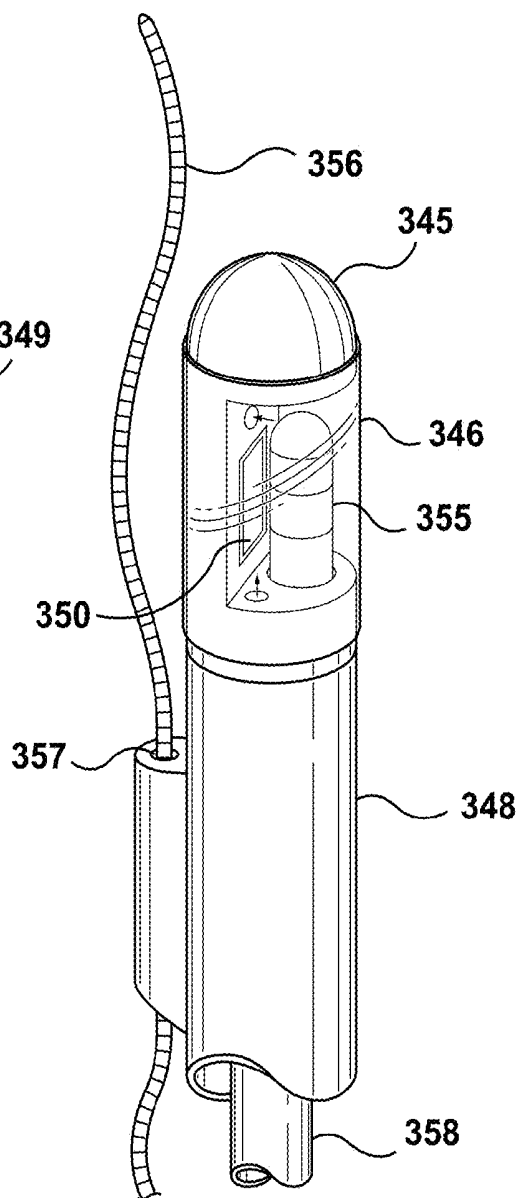

FIG. 15B

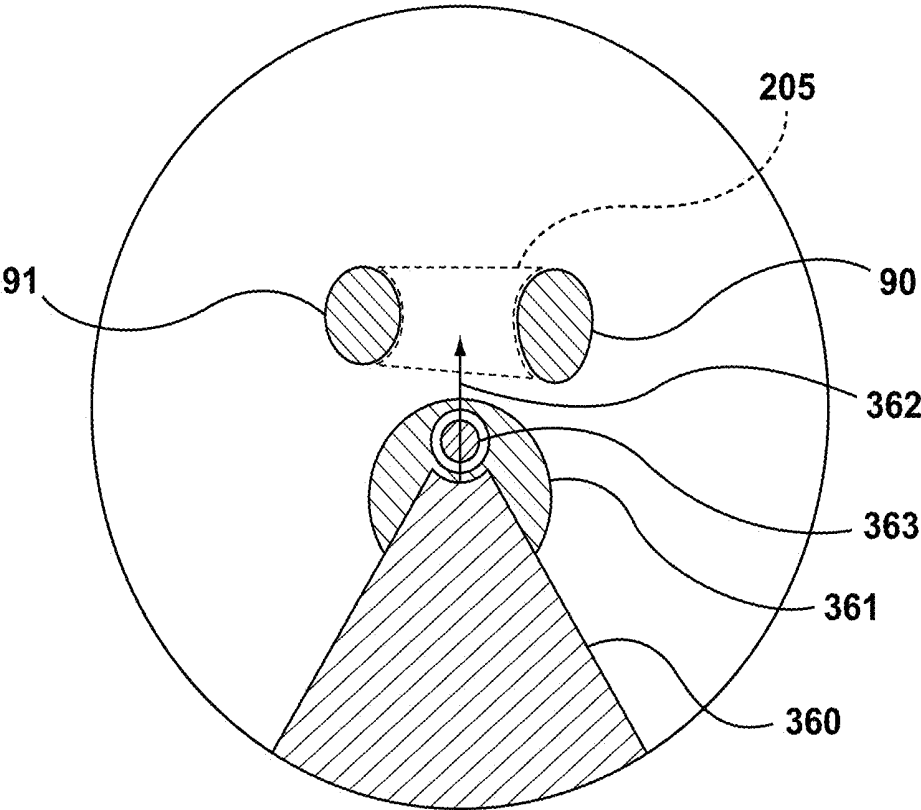

FIG. 16

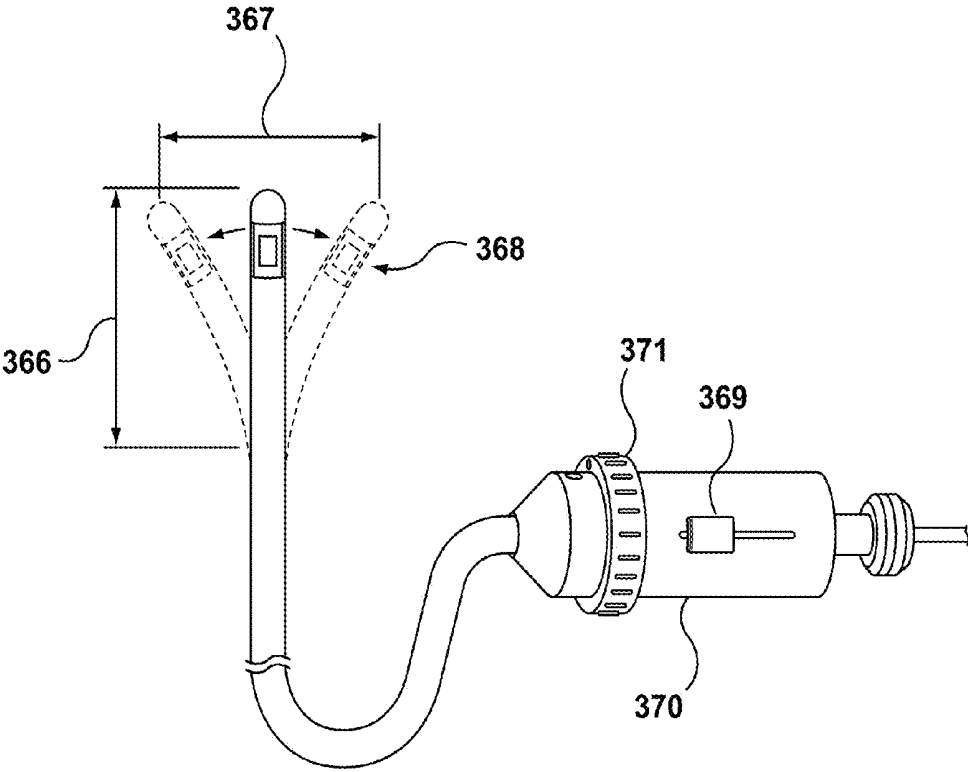

FIG. 17

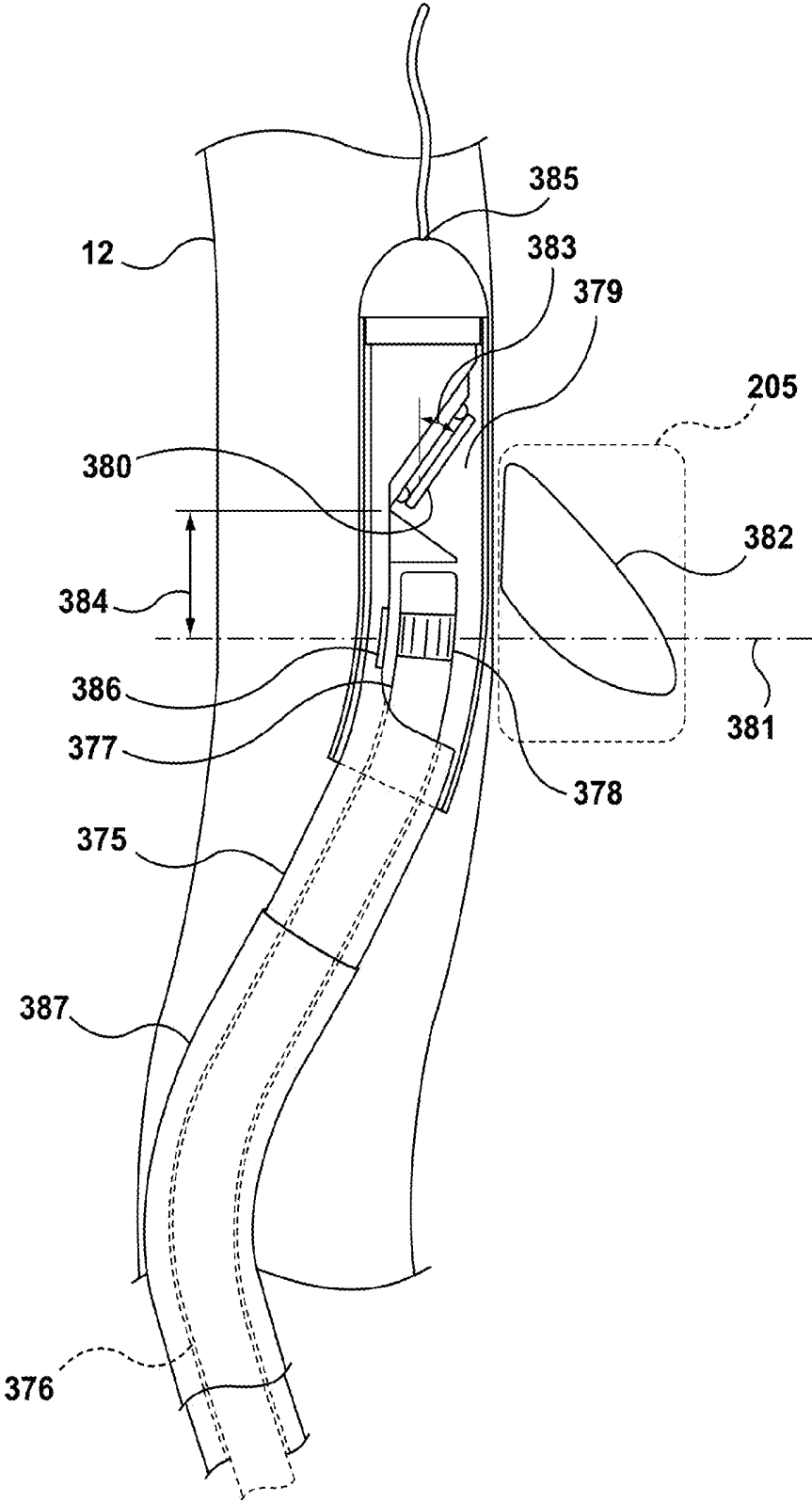

FIG. 18

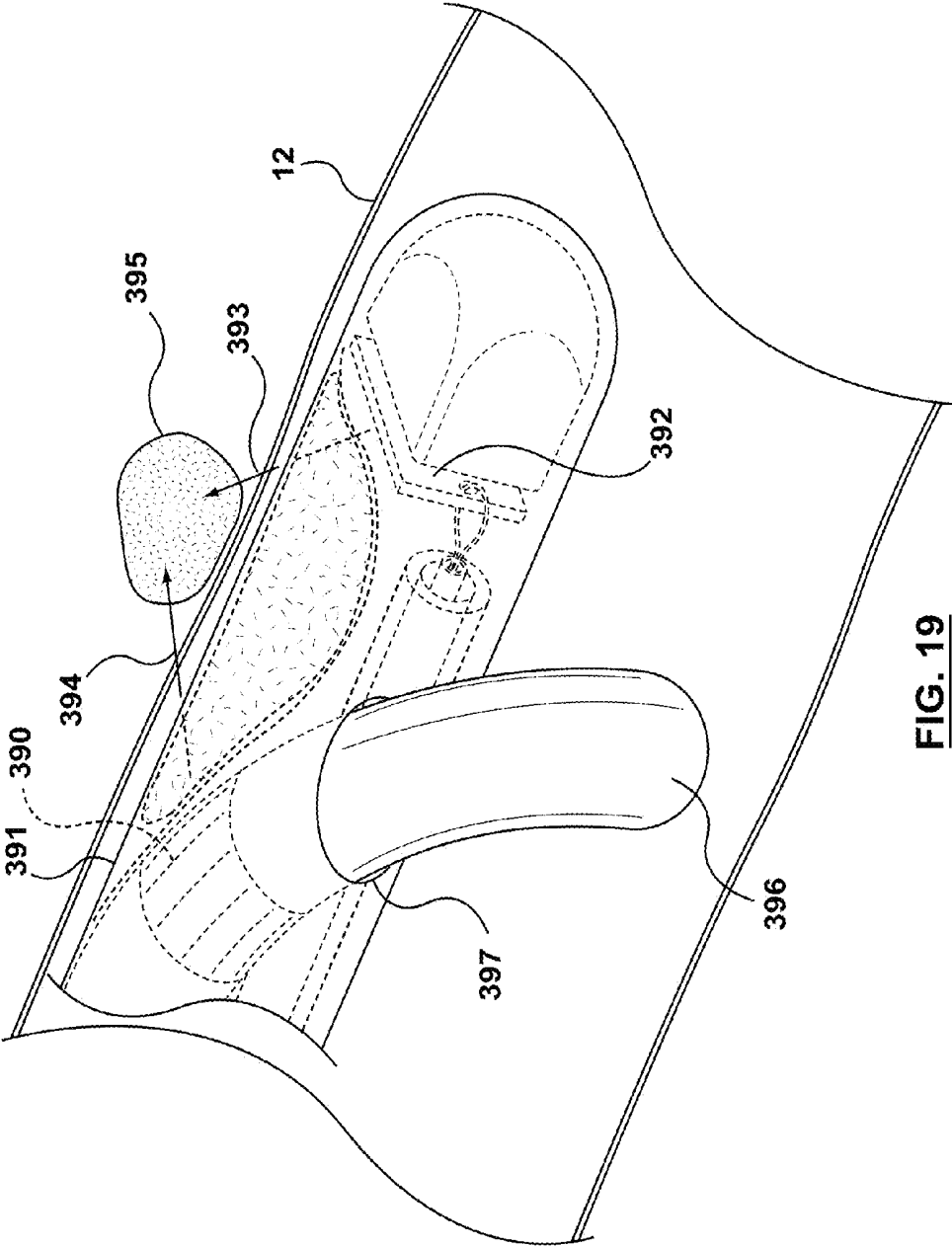

FIG. 19

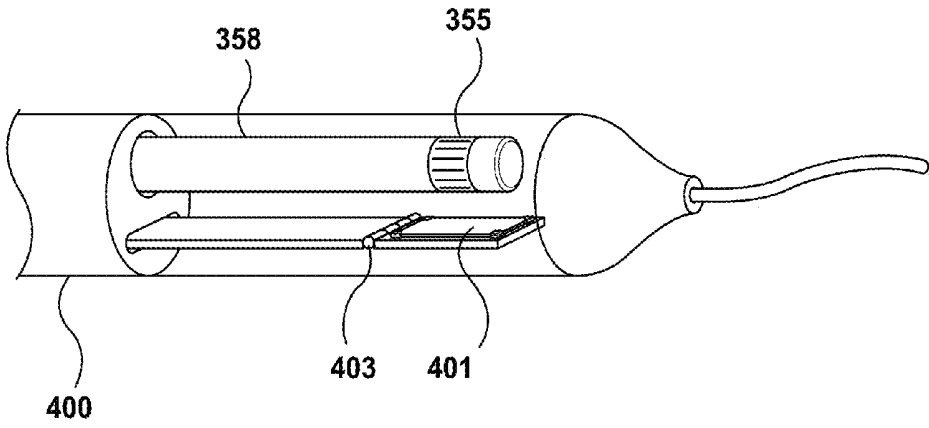

FIG. 20A

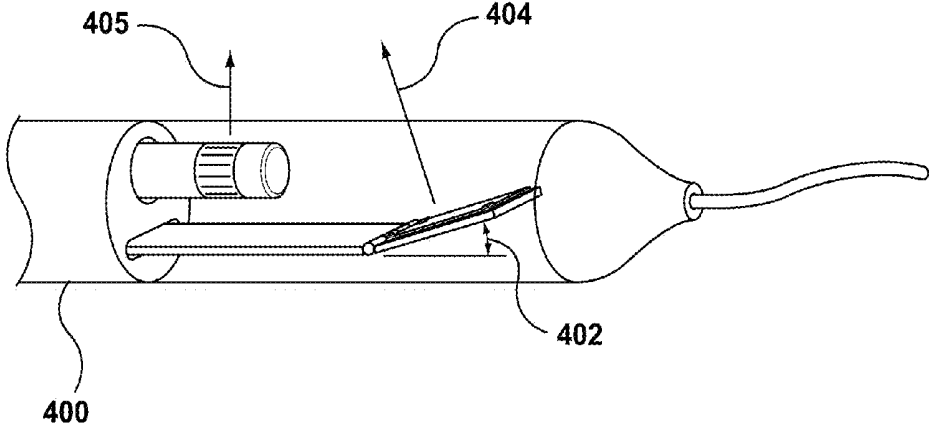

FIG. 20B

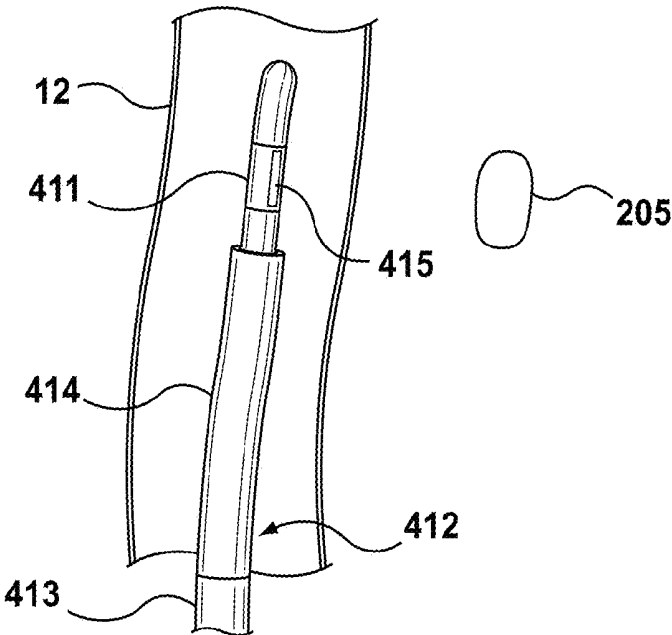

FIG. 21A

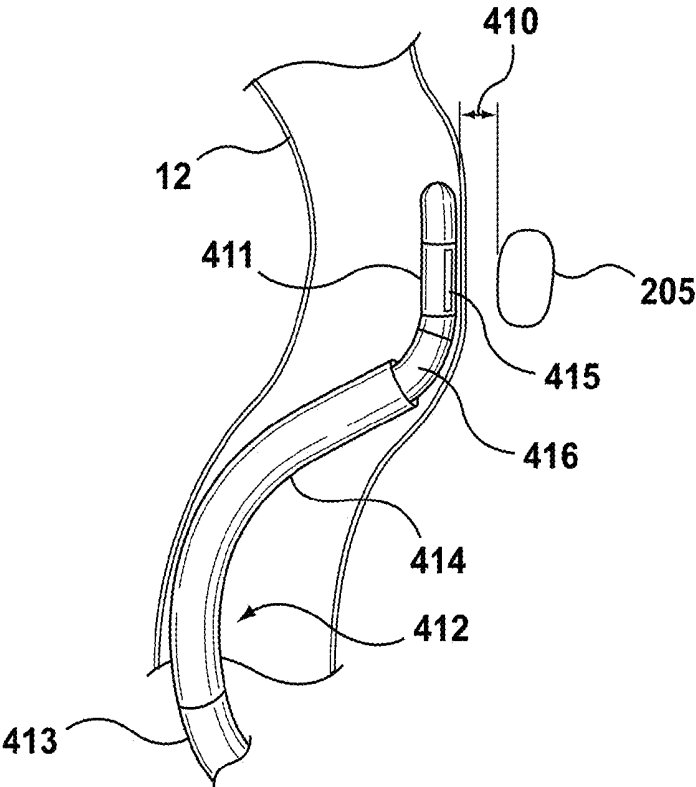

FIG. 21B

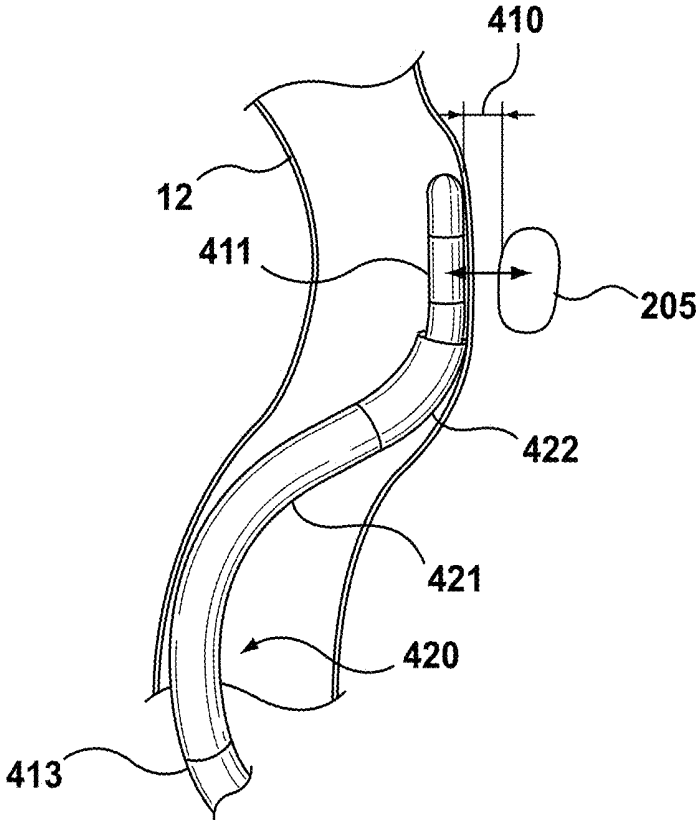

FIG. 21C

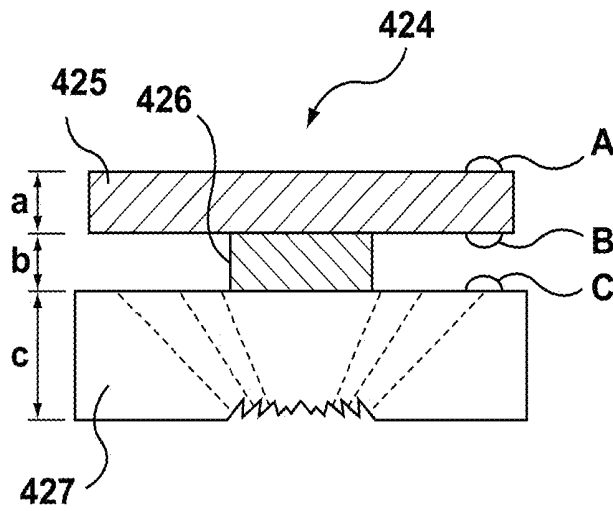

FIG. 22A

Mode	Electrodes	Frequency
Ablation	A B	$\sim \frac{1}{a}$
Imaging	A C	$\sim \frac{1}{a + b}$

FIG. 22B

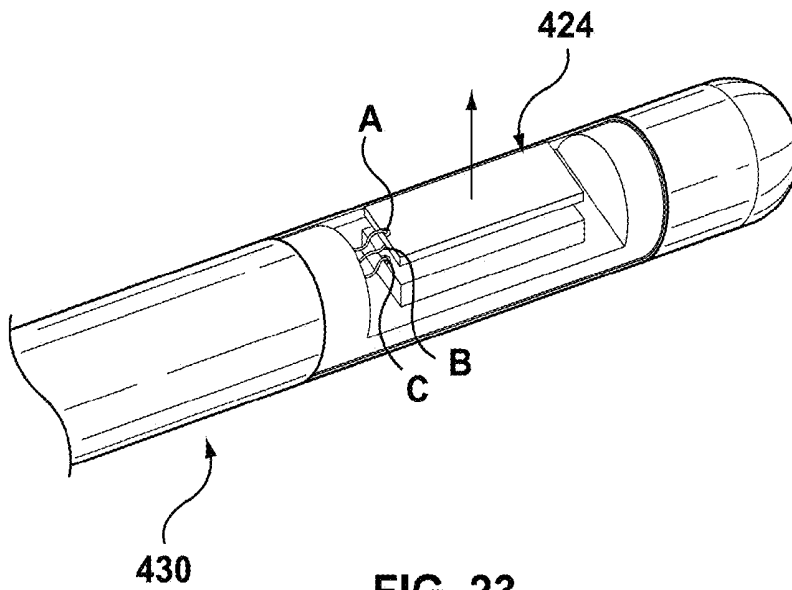

FIG. 23

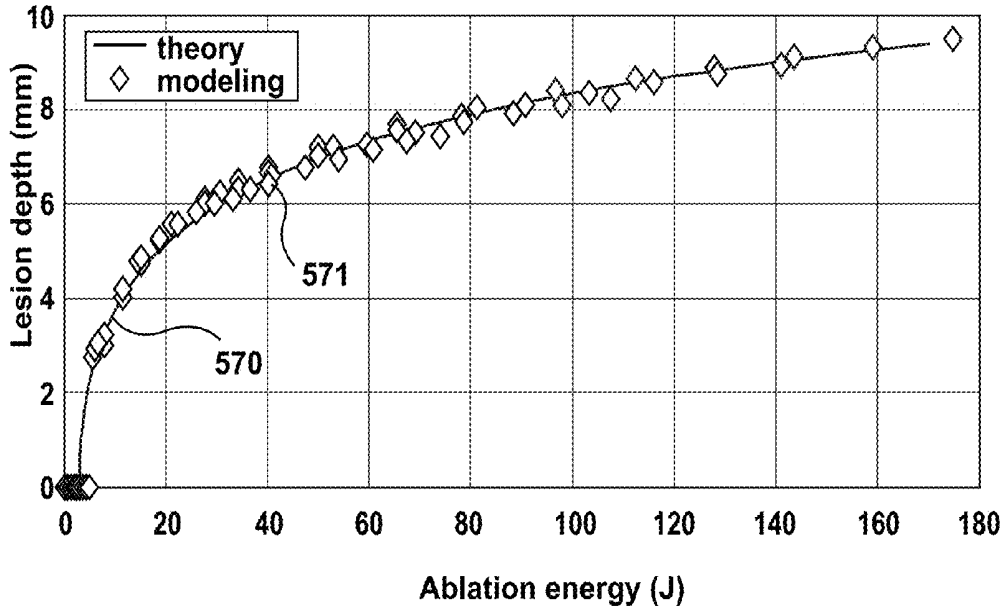

FIG. 24A

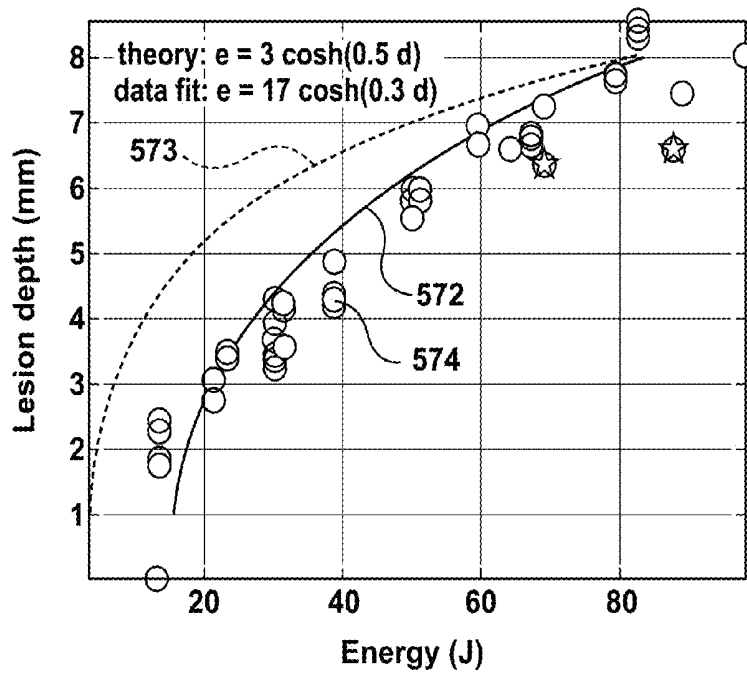
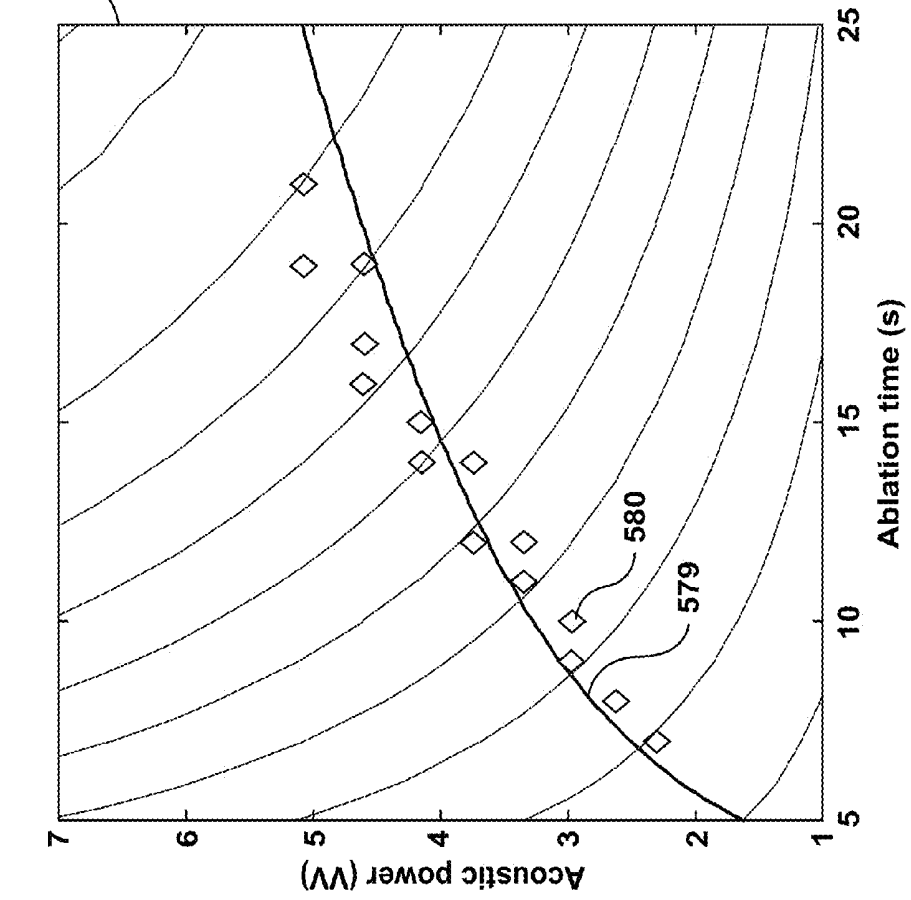
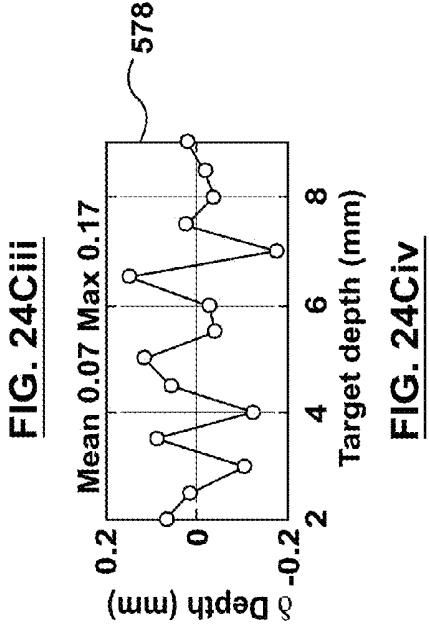
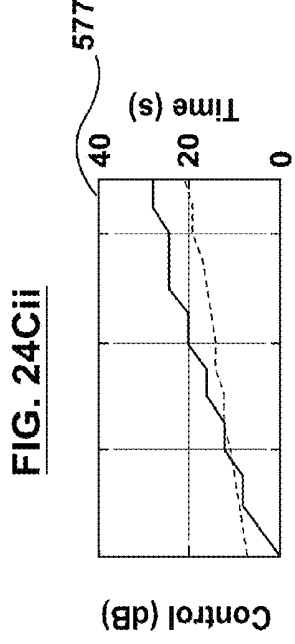
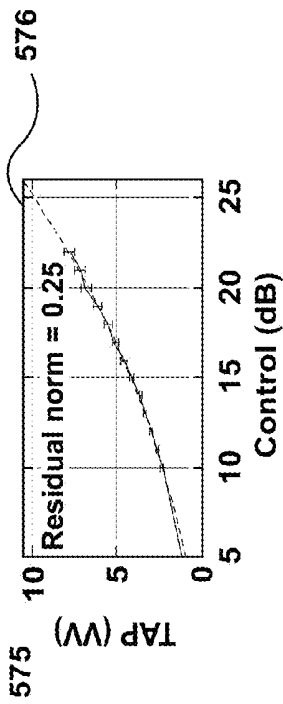

FIG. 24B



0002 20150115 20150117T213425
TAP residual norm 0.34W
Depth deviation mean max 0.08 0.18 mm
2.00 16 07 2.29 1.93
2.50 17 08 2.57 2.44
3.00 18 09 2.90 3.04
3.50 19 09 3.27 3.40
4.00 19 11 3.27 4.06
4.50 19 12 3.27 4.37
5.00 20 12 3.70 4.85
5.50 20 14 3.70 5.51
6.00 20 15 3.70 5.82
6.50 21 15 4.18 6.40
7.00 21 17 4.18 7.01
7.50 22 17 4.73 7.63
8.00 22 18 4.73 7.91
8.50 22 20 4.73 8.43
9.00 22 23 4.73 9.08

FIG. 25

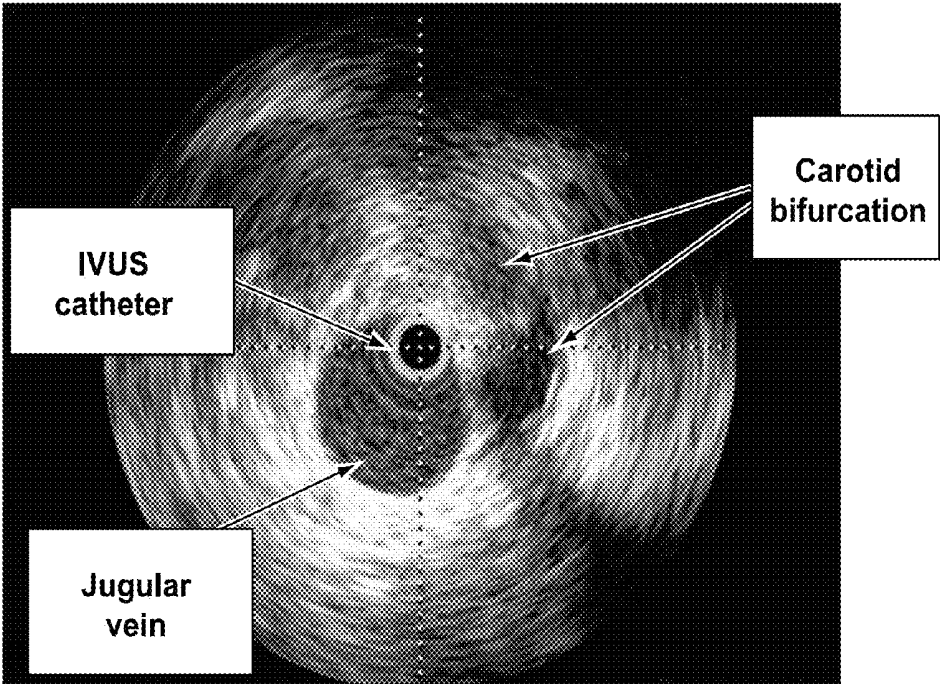

FIG. 26

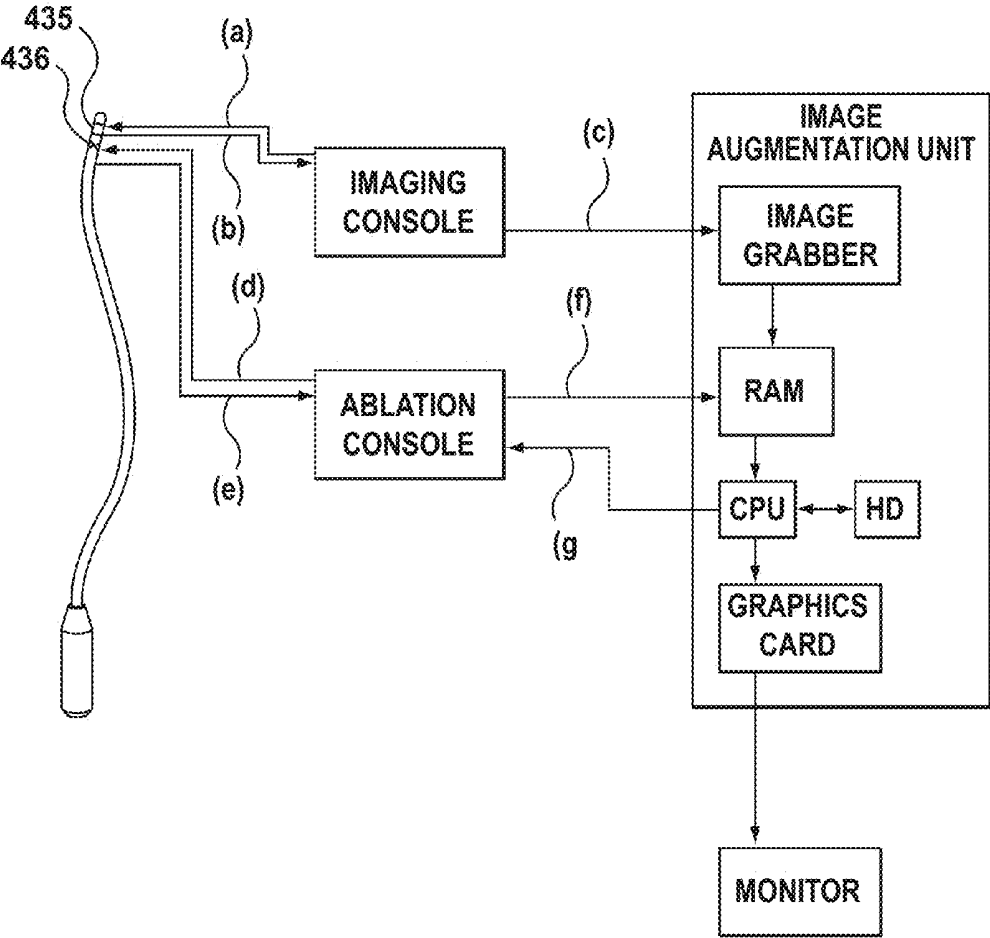

FIG. 27

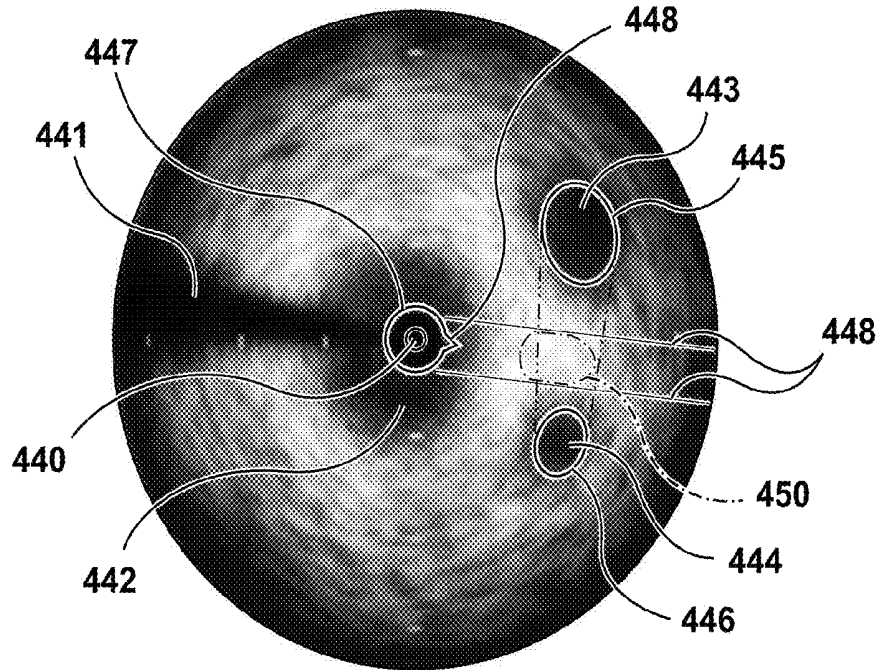

FIG. 28

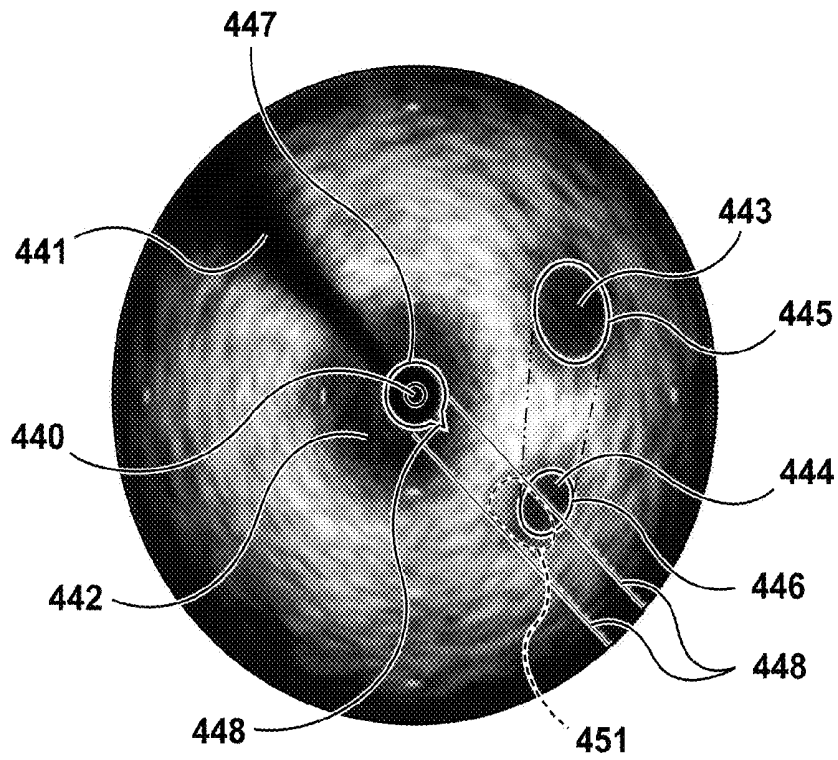

FIG. 29

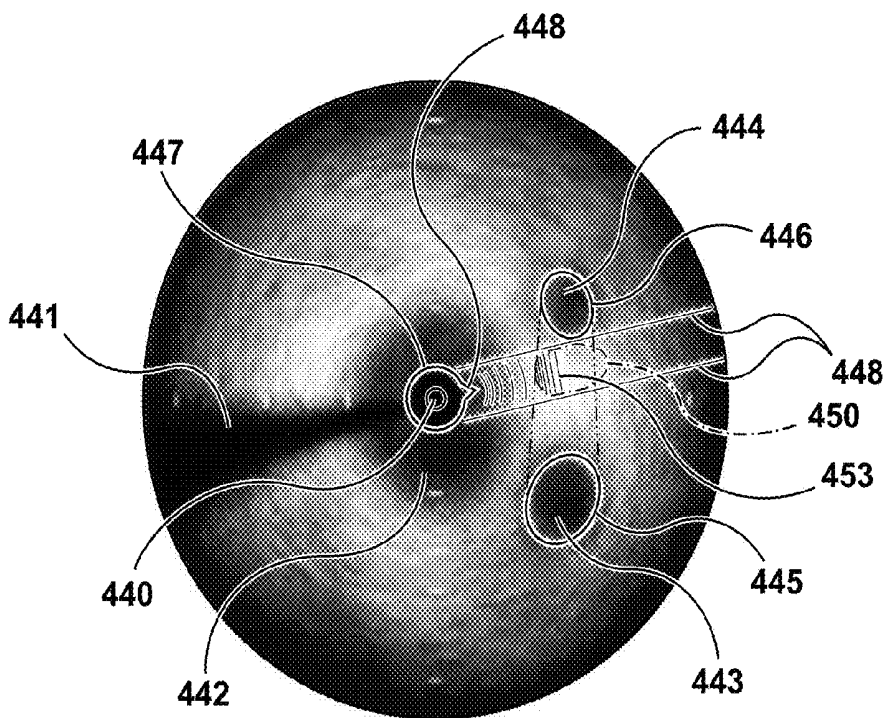

FIG. 30

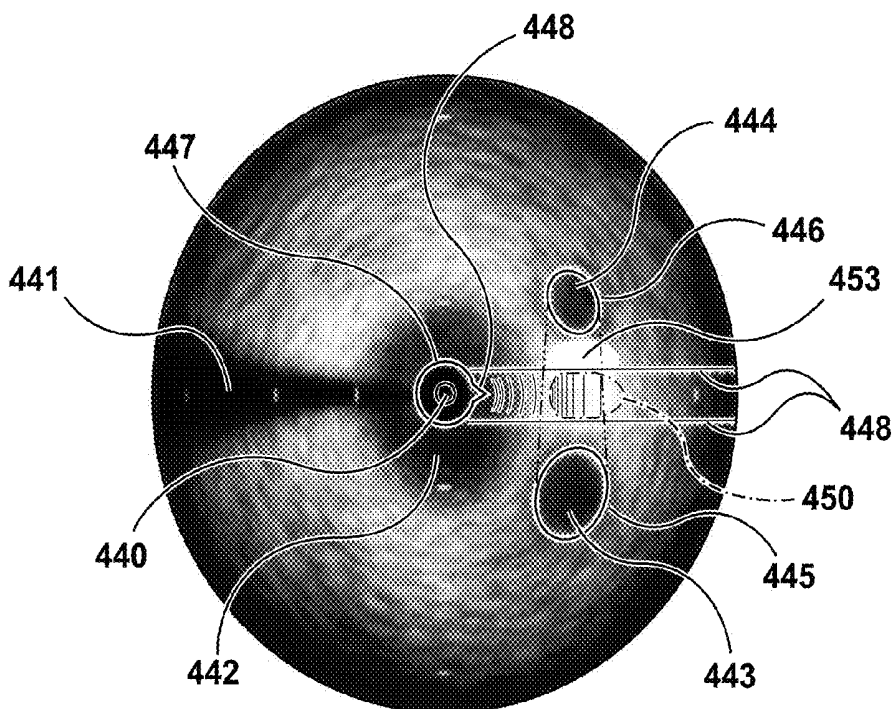

FIG. 31

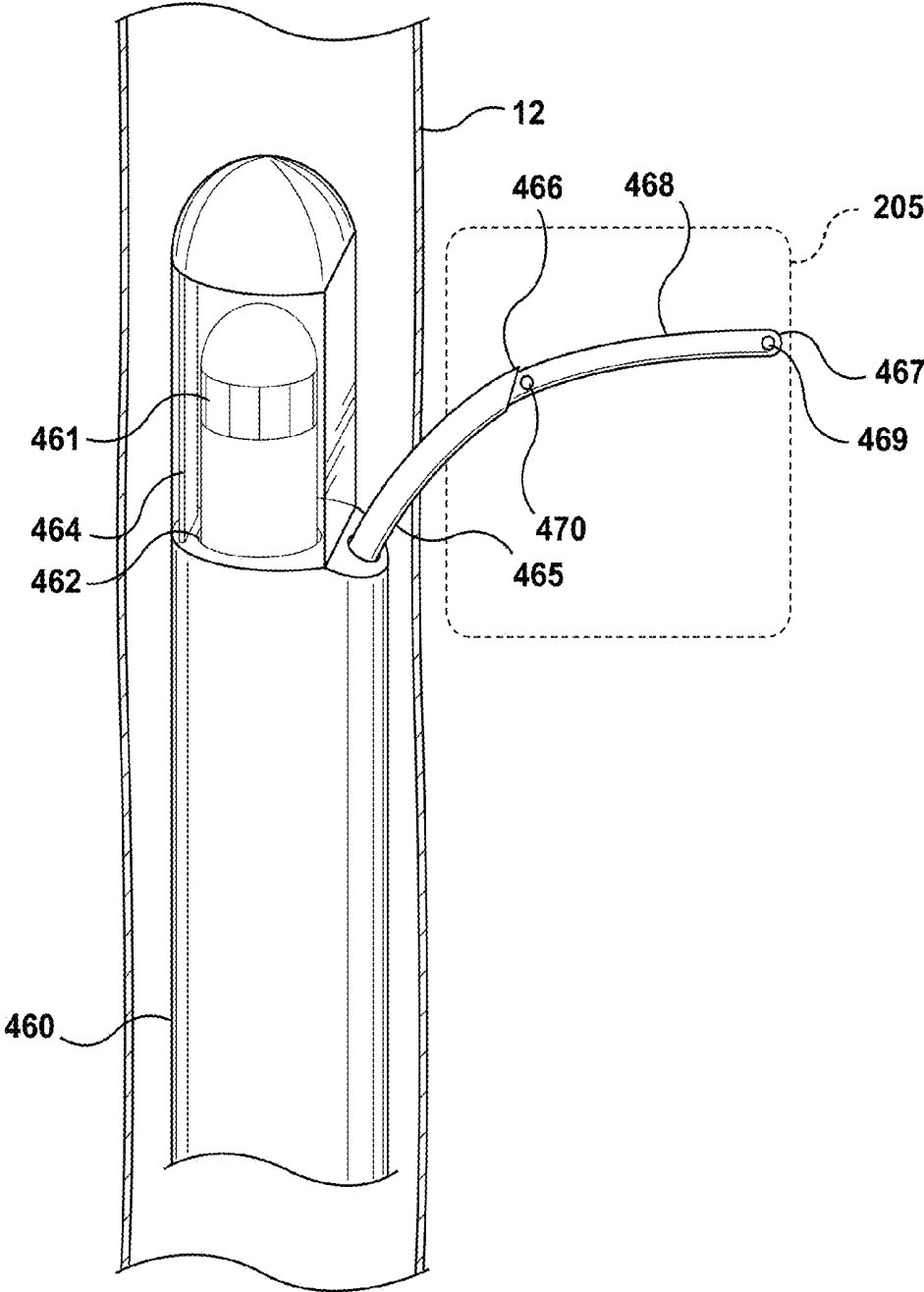

FIG. 32

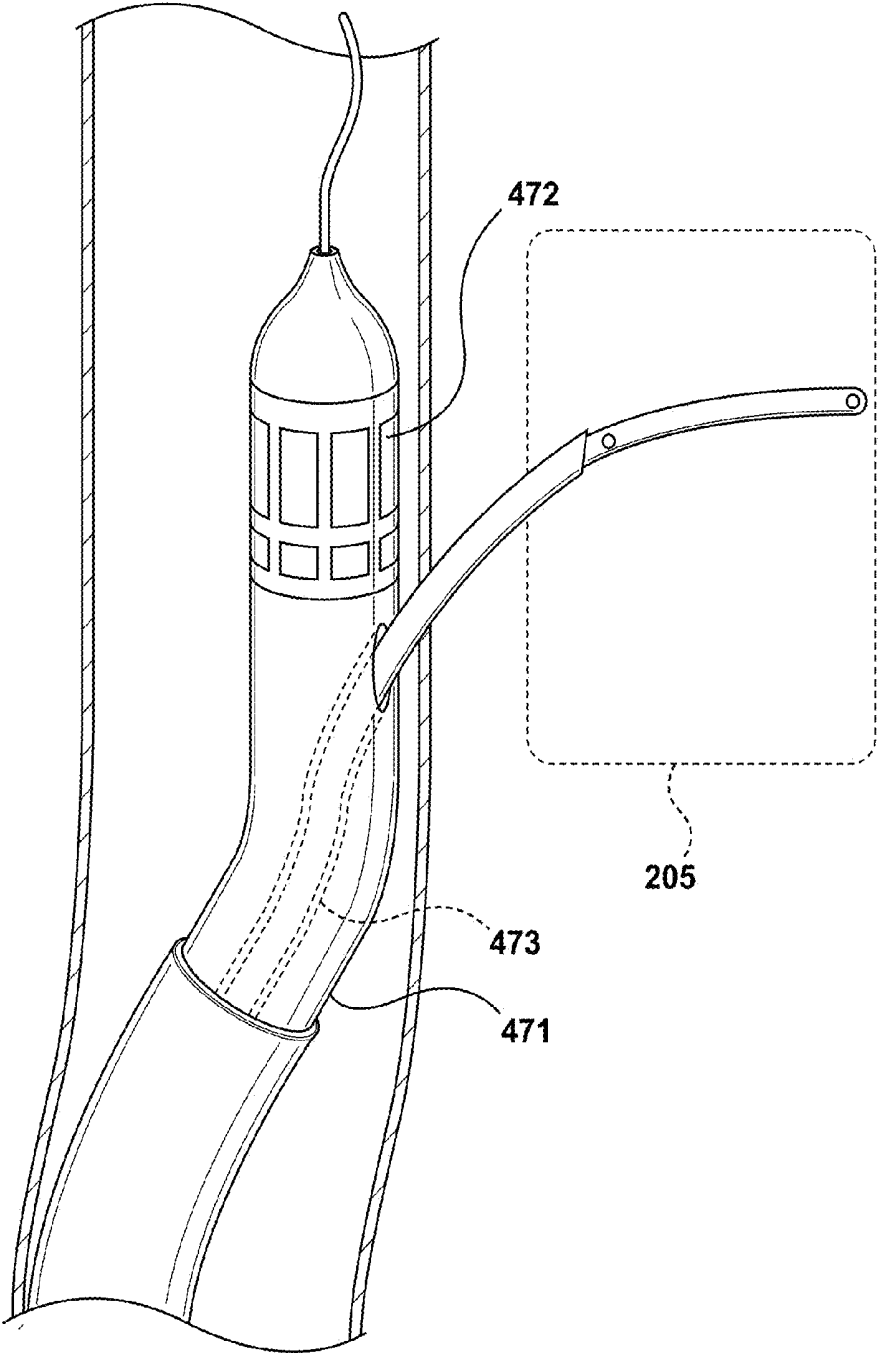

FIG. 33

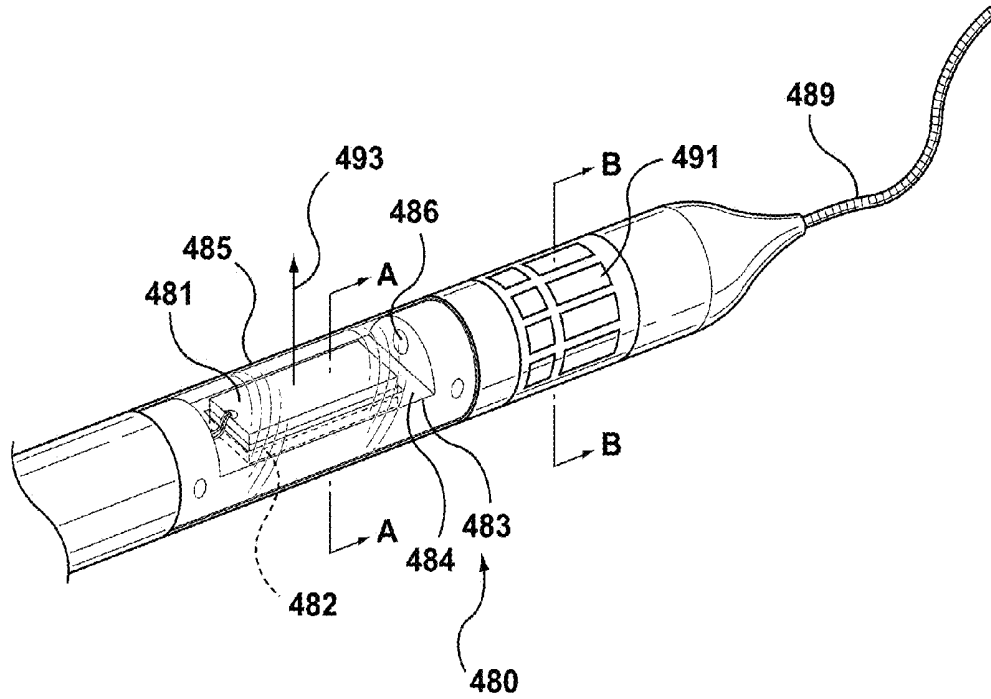
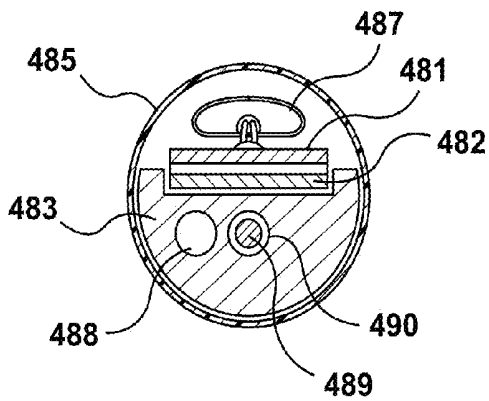
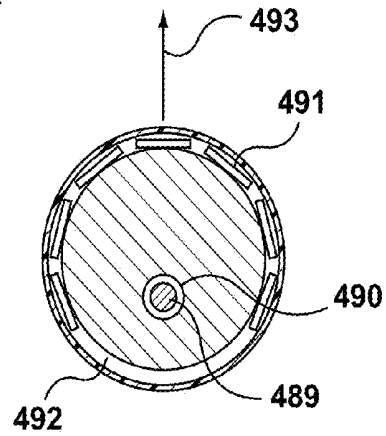

FIG. 34A



Section A - A

FIG. 34B



Section B - B

FIG. 34C

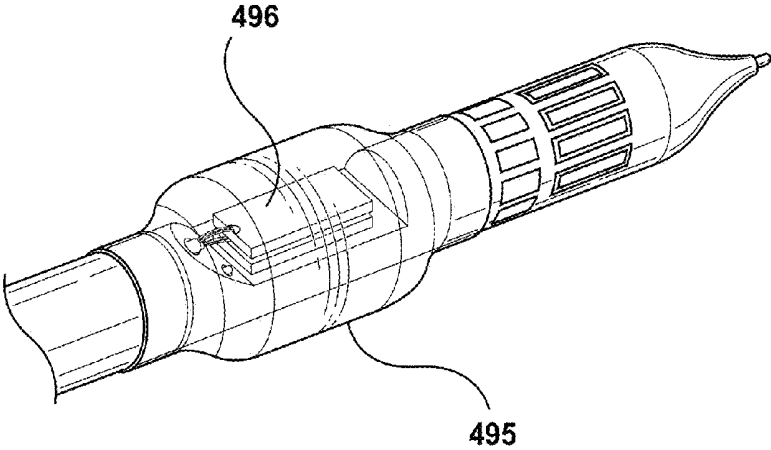

FIG. 35

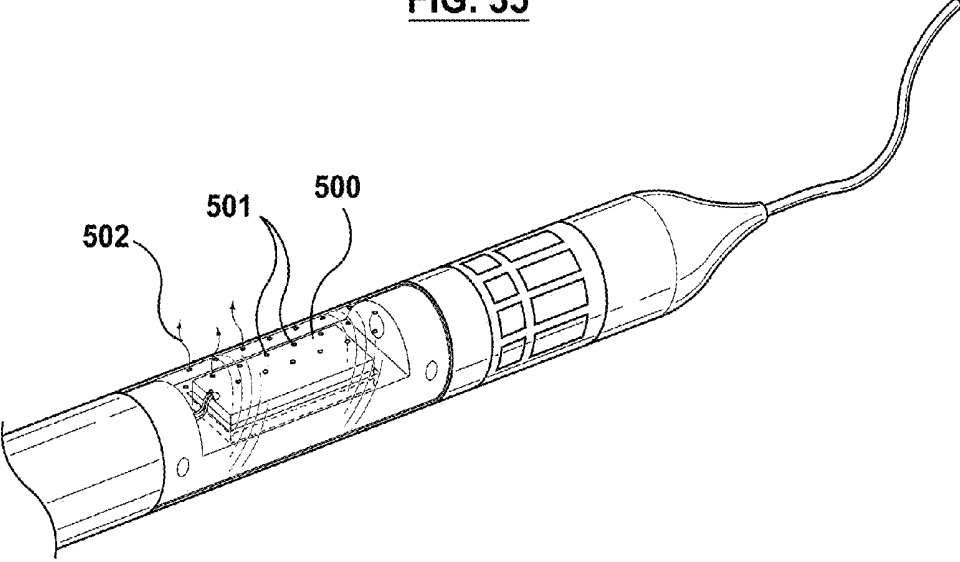

FIG. 36

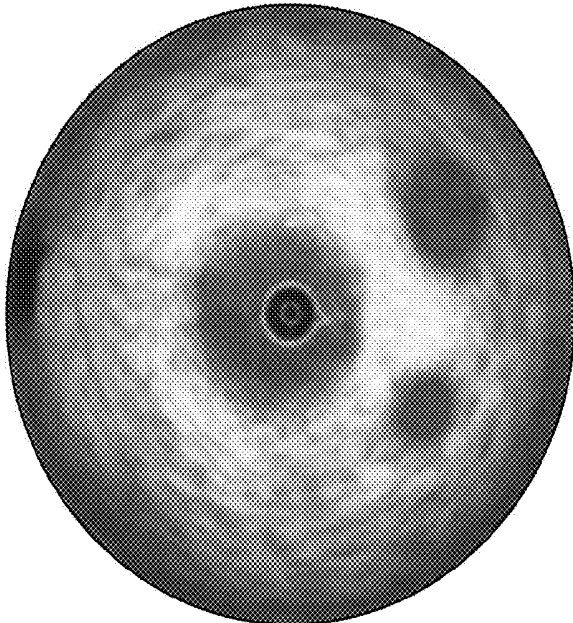

FIG. 37A

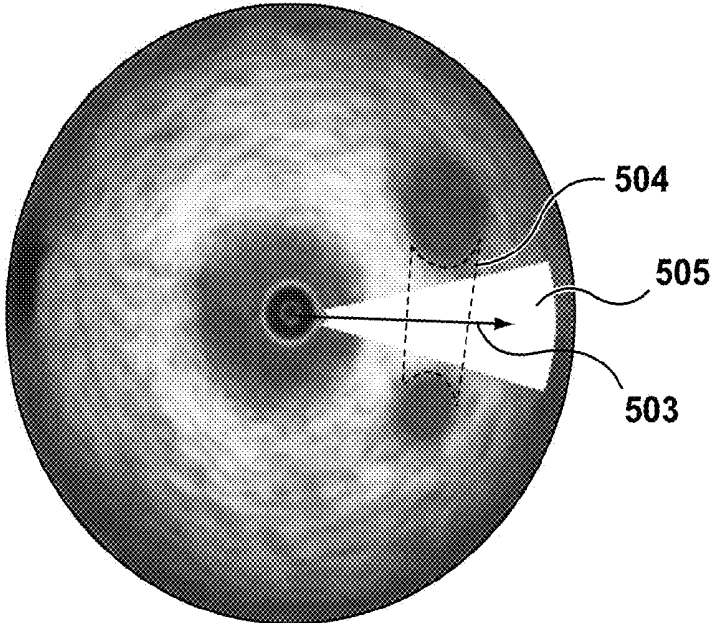

FIG. 37B

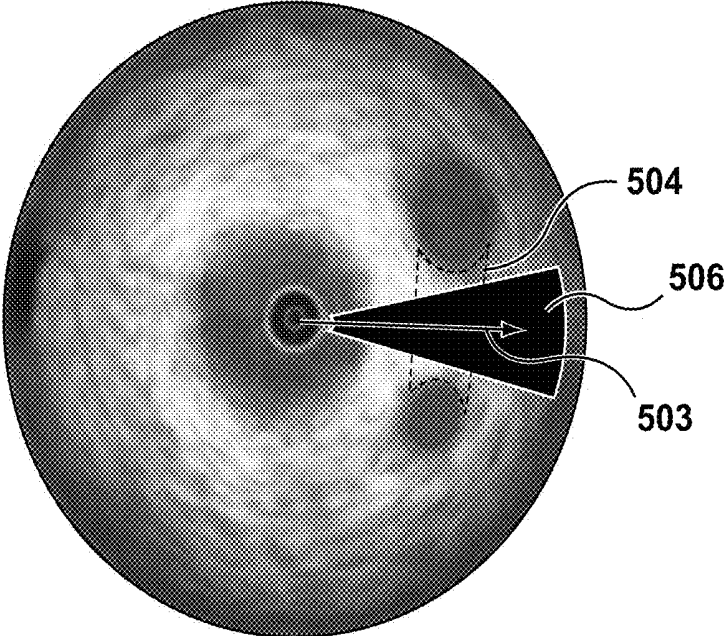

FIG. 37C

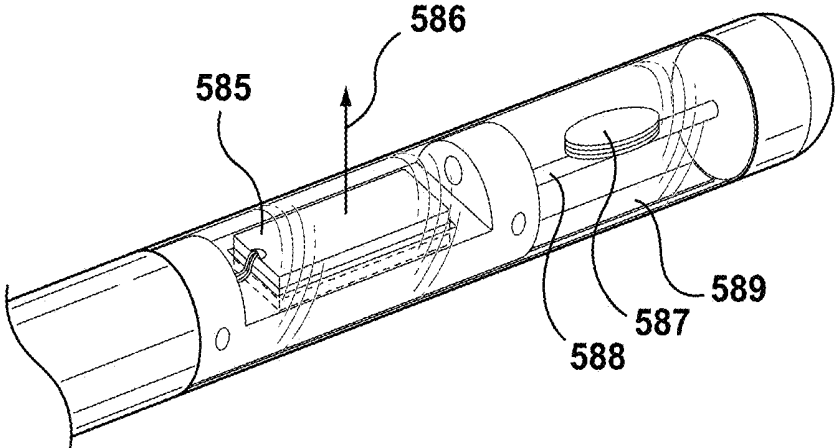

FIG. 38

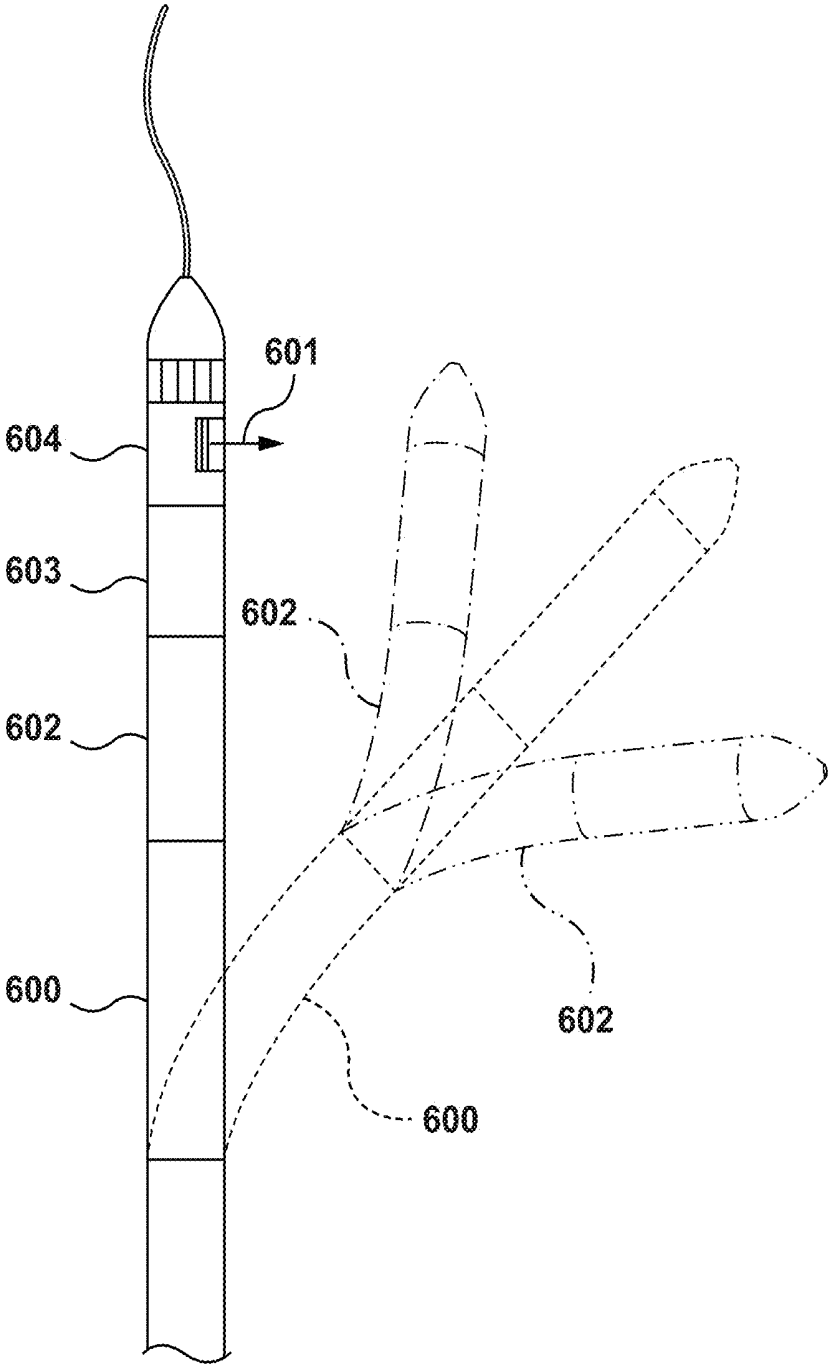

FIG. 39

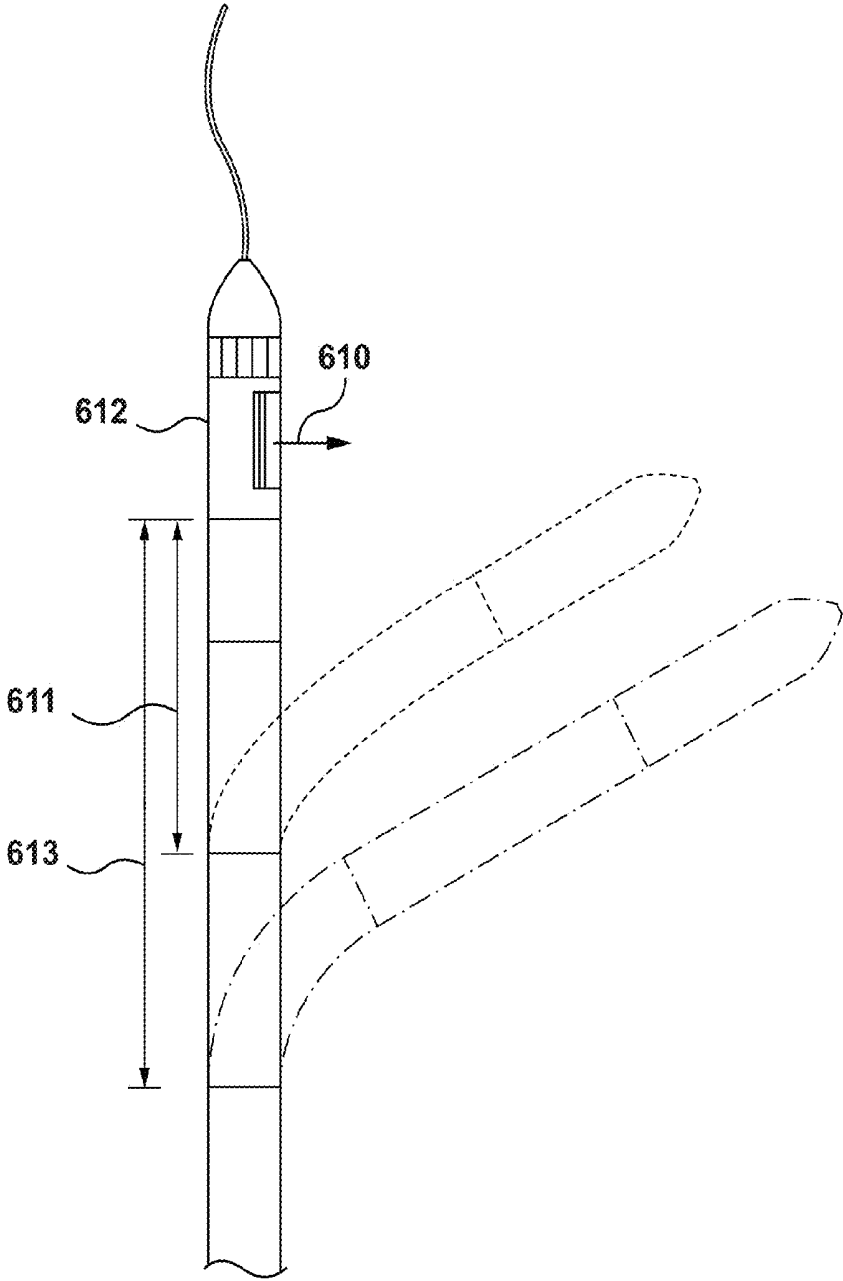

FIG. 40

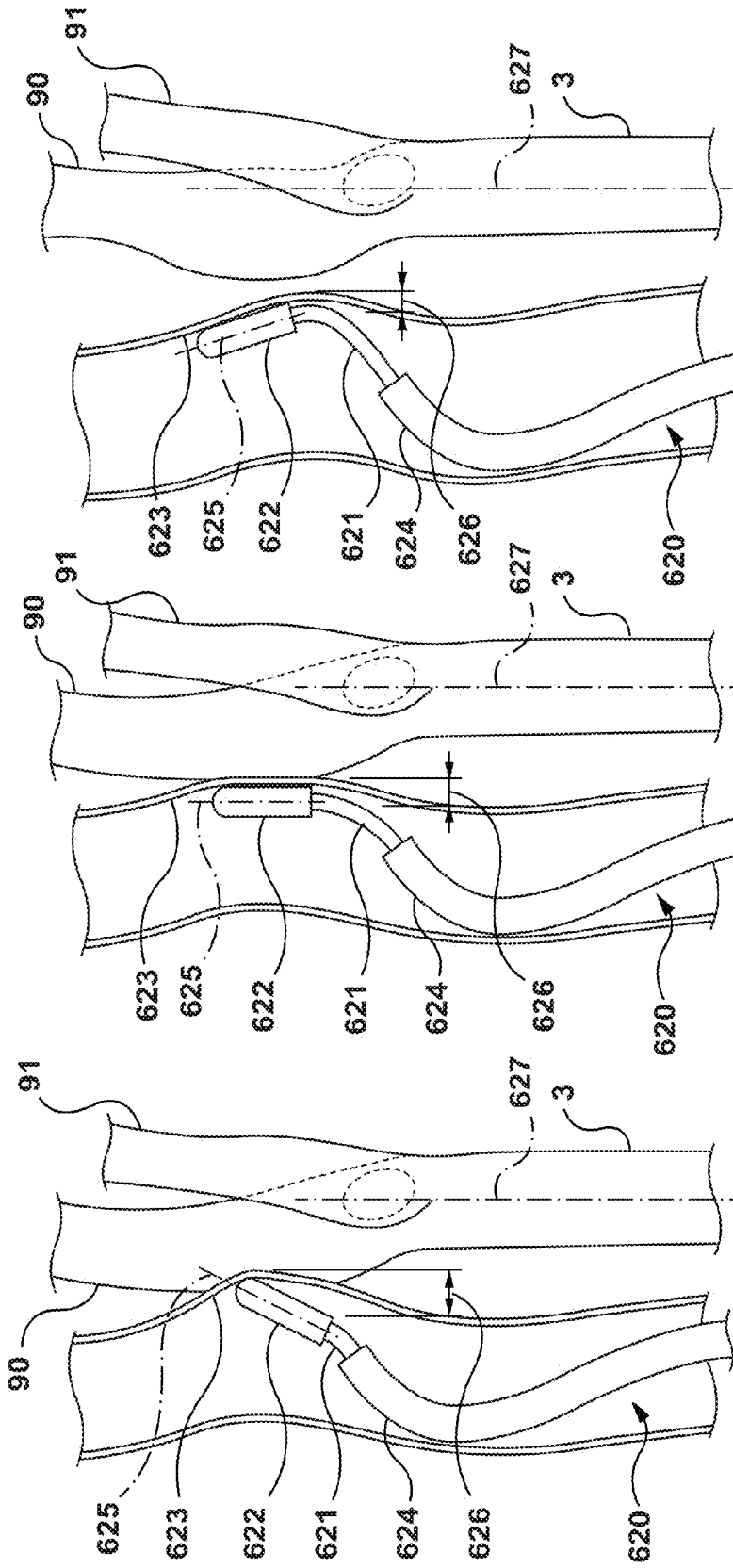

FIG. 41A

FIG. 41B

FIG. 41C

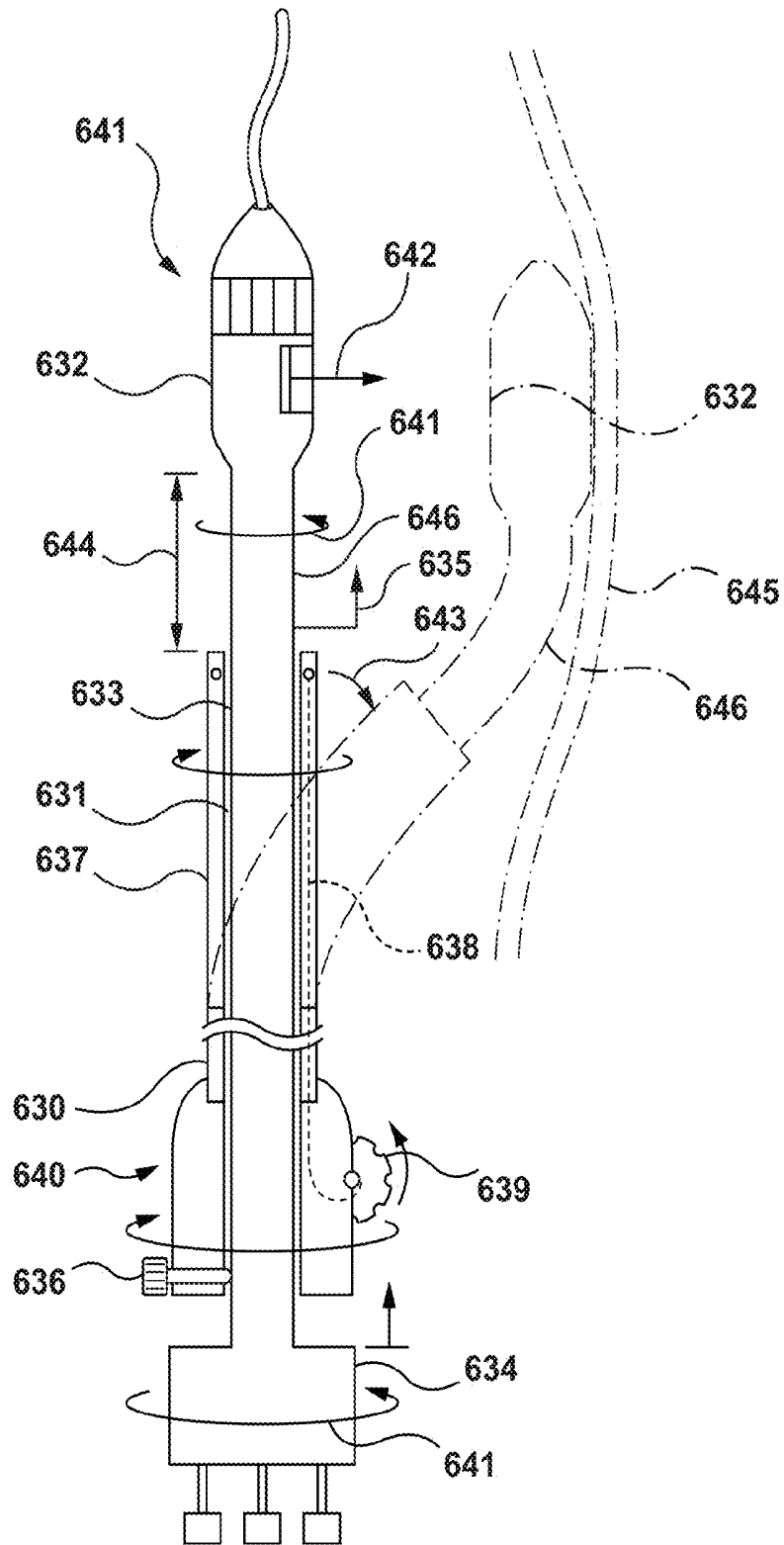

FIG. 42

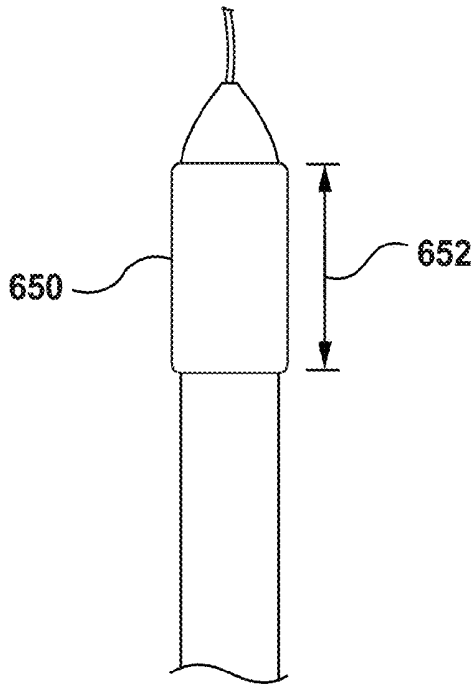

FIG. 43A

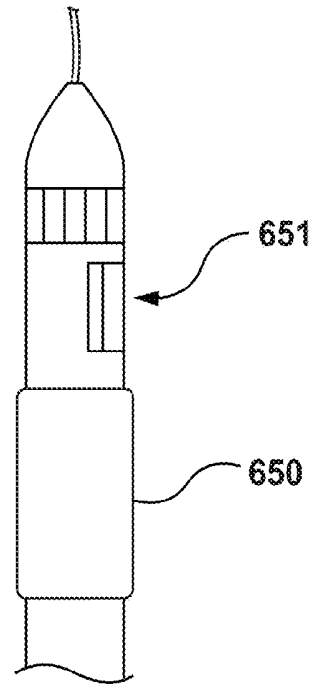

FIG. 43B

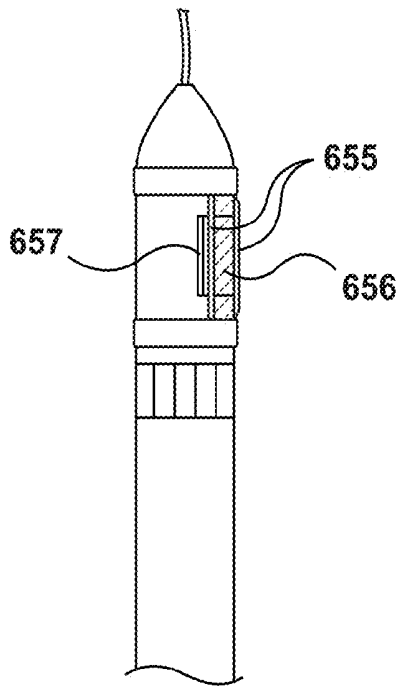

FIG. 43C

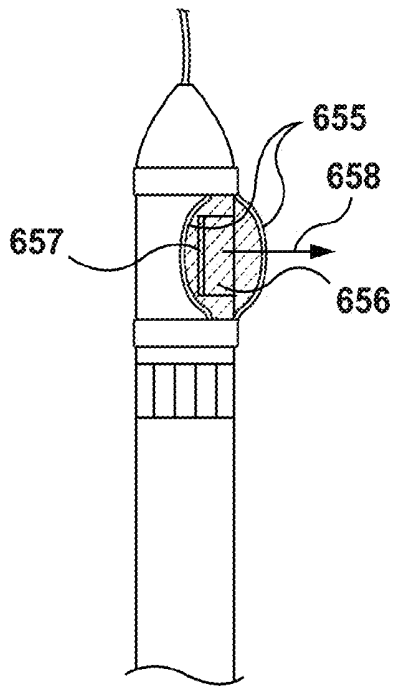

FIG. 43D

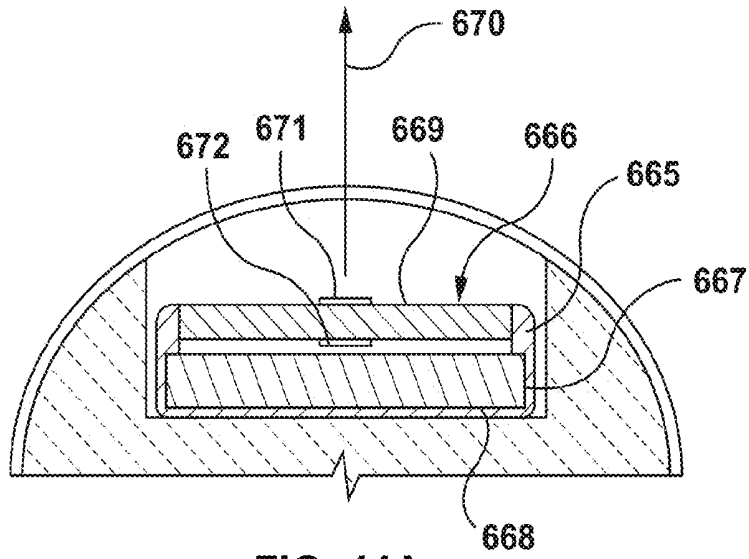

FIG. 44A

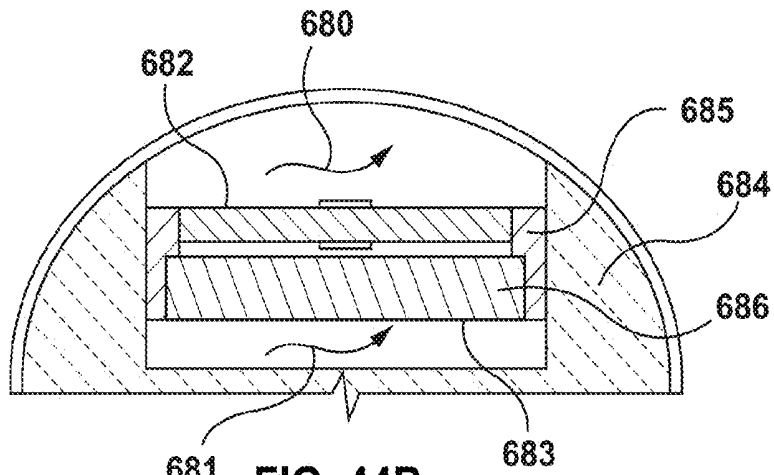

FIG. 44B

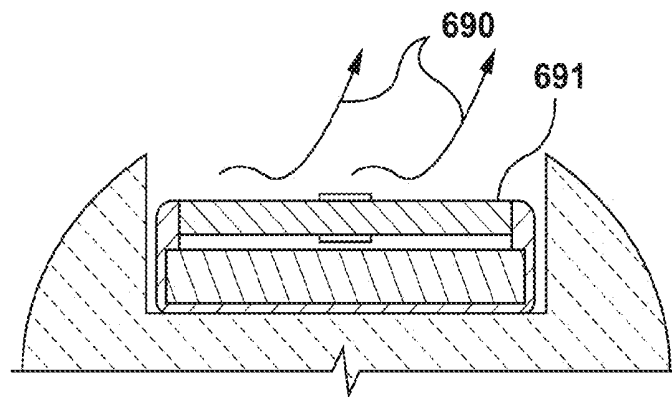

FIG. 44C

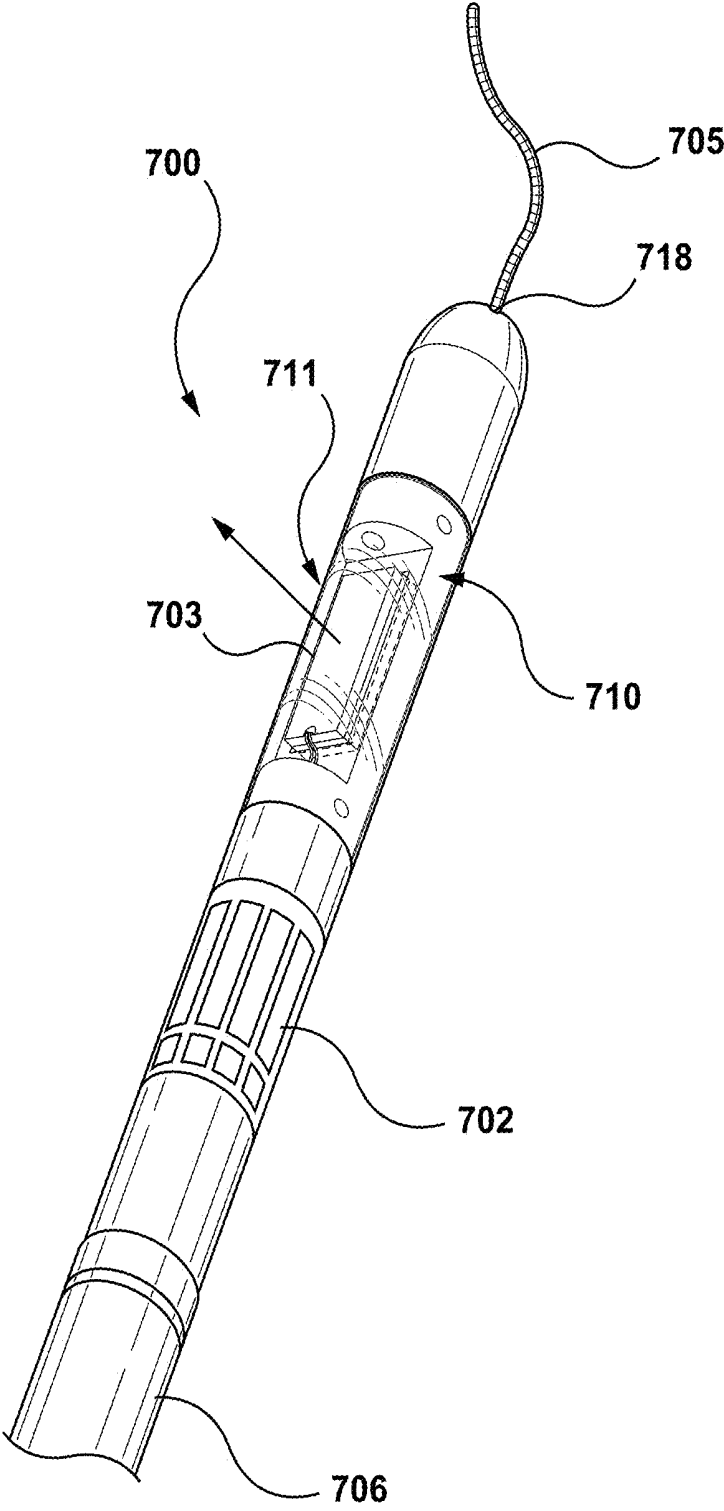

FIG. 45A

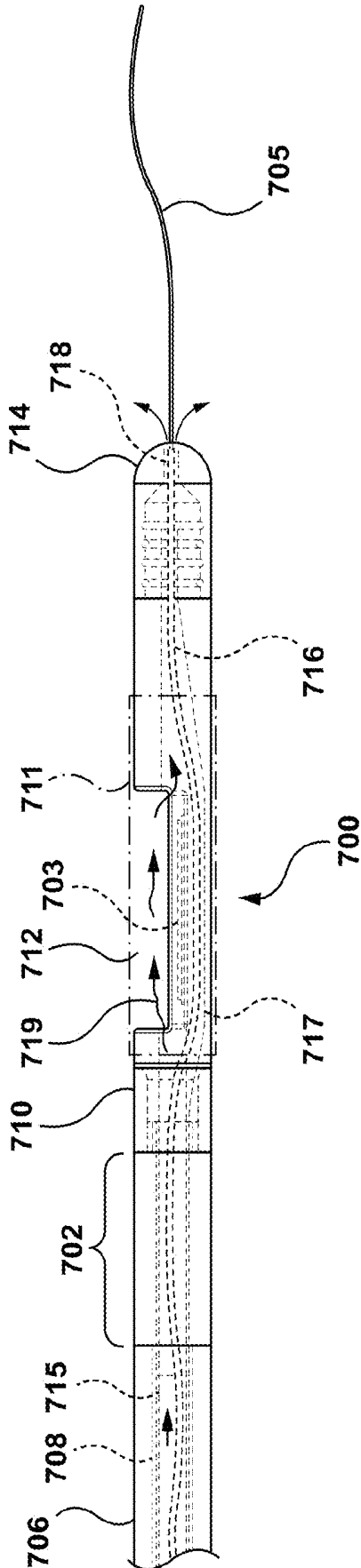

FIG. 45B

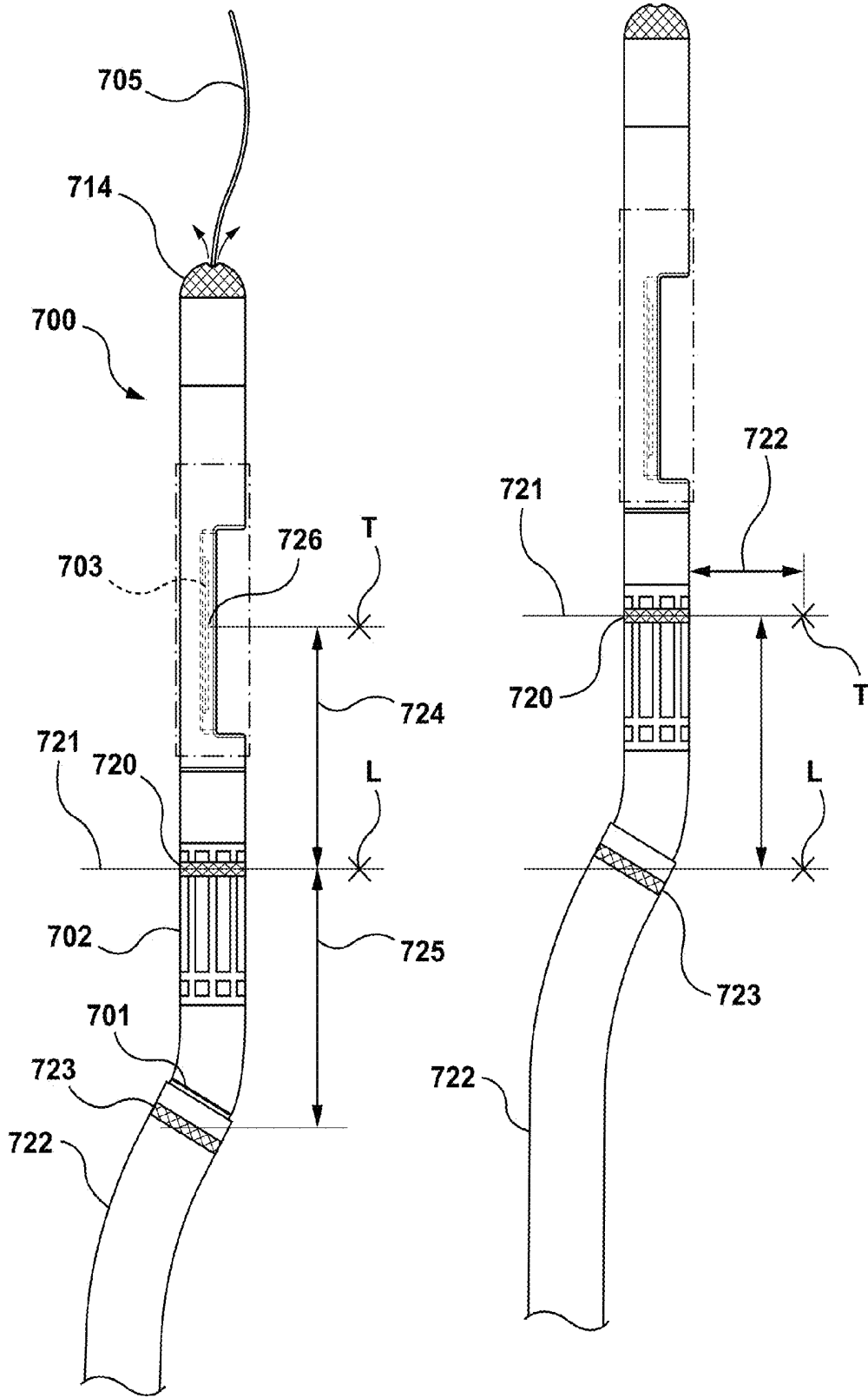

FIG. 45C

FIG. 45D

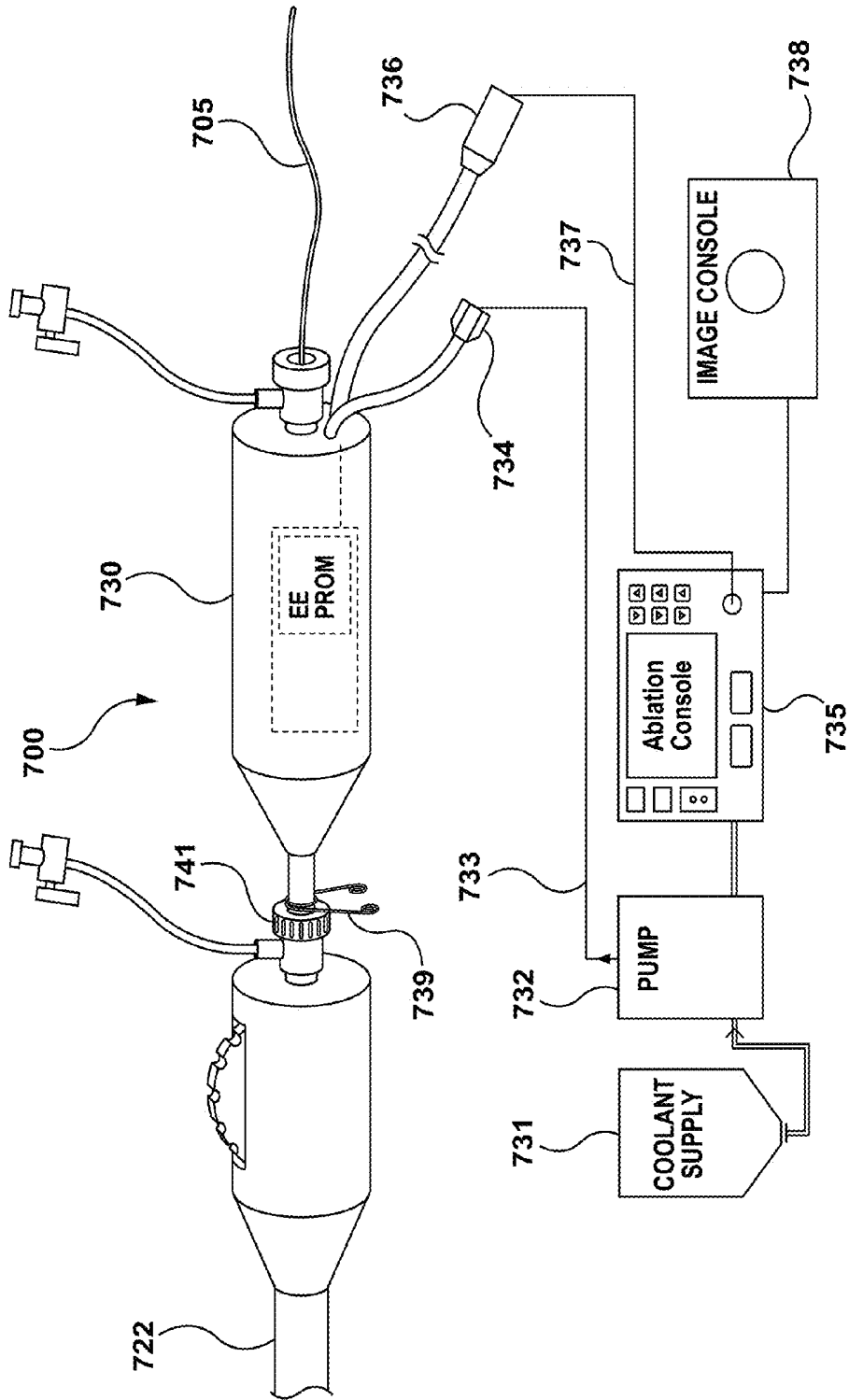

FIG. 45E

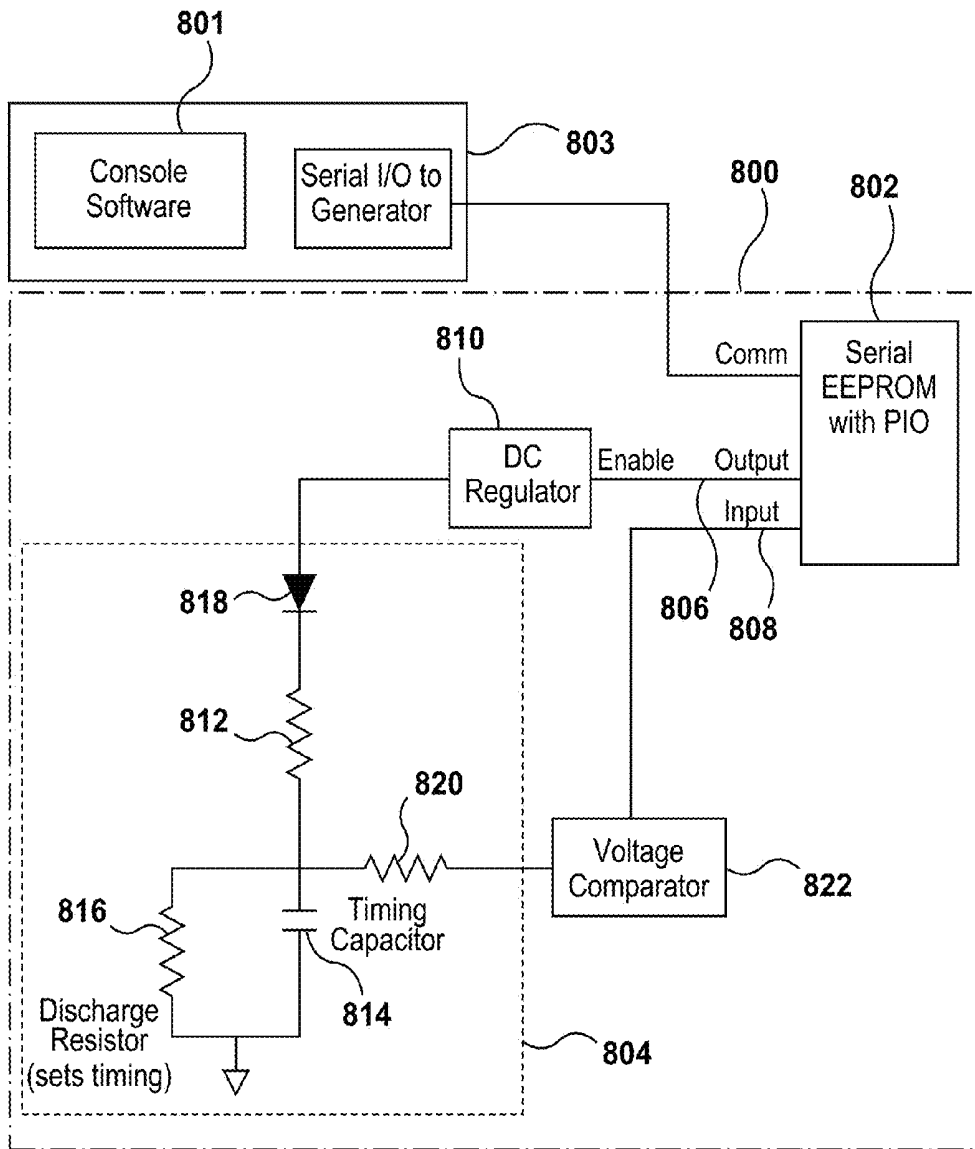

FIG. 46A

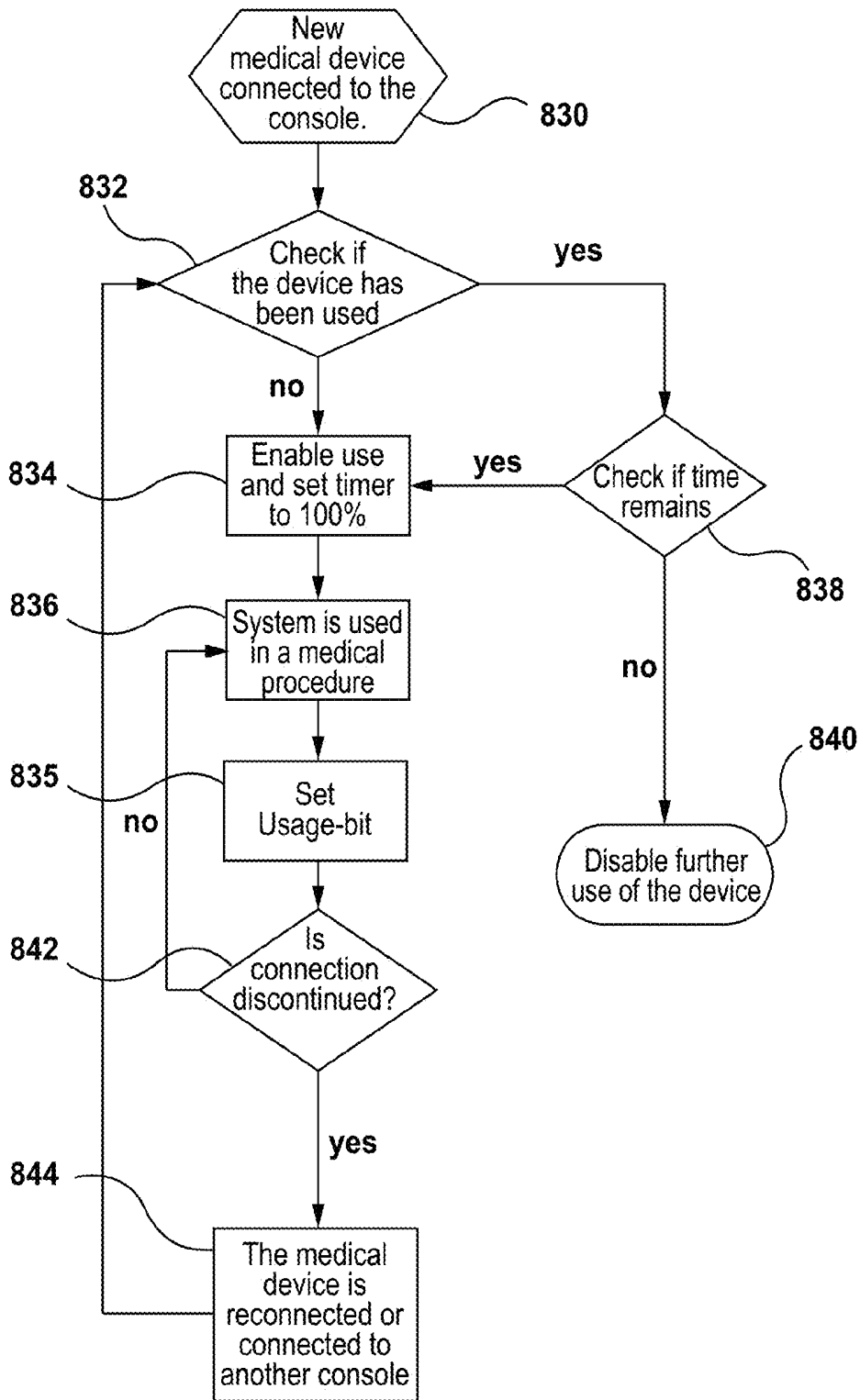

FIG. 46B

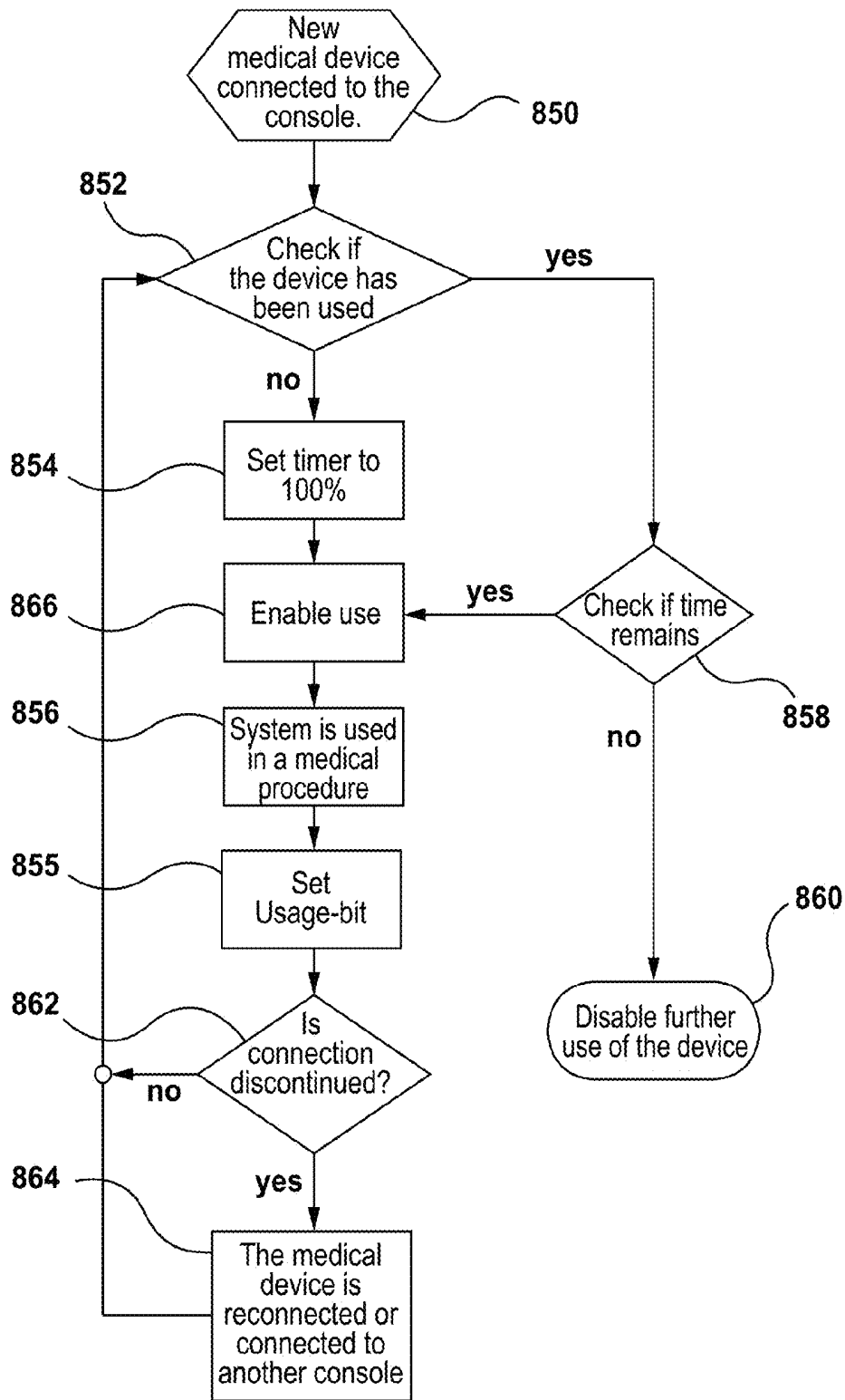

FIG. 46C

**CAROTID BODY ABLATION WITH A
TRANSVENOUS ULTRASOUND IMAGING
AND ABLATION CATHETER**

INCORPORATION BY REFERENCE

[0001] This application is a continuation-in-part of U.S. application Ser. No. 15/069,531, filed Mar. 14, 2016, which claims priority to U.S. Provisional Application No. 62/132,459, filed Mar. 12, 2015, the disclosures of which are all incorporated by reference herein.

[0002] U.S. application Ser. No. 15/069,531 is a continuation-in-part of U.S. application Ser. No. 14/656,635, filed Mar. 12, 2015, which claims priority to the following U.S. Provisional Applications: App. No. 61/952,015, filed Mar. 12, 2014; App. No. 62/017,148, filed Jun. 25, 2014; and App. No. 62/049,980, filed Sep. 12, 2014. The disclosures of the aforementioned applications are all incorporated by reference herein.

[0003] This application also claims the benefit of the following U.S. Provisional Applications, the disclosures of which are both incorporated by reference herein: App. No. 62/217,570, filed Sep. 11, 2015, and App. No. 62/219,595, filed Sep. 16, 2015.

[0004] The following applications are also incorporated herein by reference: U.S. Pat. No. 9,283,033, issued Mar. 15, 2016; and U.S. Publication 2014/0350401, which published on Nov. 27, 2014.

[0005] All publications and patent applications mentioned in this specification are herein incorporated by reference to the same extent as if each individual publication or patent application was specifically and individually indicated to be incorporated by reference.

TECHNICAL FIELD

[0006] The present disclosure is directed generally to systems and methods for treating patients having sympathetically mediated disease associated at least in part with augmented peripheral chemoreflex or heightened sympathetic activation by ablating at least one of a carotid body, two carotid bodies, and a nerve associated therewith.

BACKGROUND

[0007] It is known that an imbalance of the autonomic nervous system is associated with several disease states. Restoration of autonomic balance has been a target of several medical treatments including modalities such as pharmacological, device-based, and electrical stimulation. For example, beta blockers are a class of drugs used to reduce sympathetic activity to treat cardiac arrhythmias and hypertension; Gelfand and Levin (U.S. Pat. No. 7,162,303) describe a device-based treatment used to decrease renal sympathetic activity to treat heart failure, hypertension, and renal failure; Yun and Yuarn-Bor (U.S. Pat. No. 7,149,574; U.S. Pat. No. 7,363,076; U.S. Pat. No. 7,738,952) describe a method of restoring autonomic balance by increasing parasympathetic activity to treat disease associated with parasympathetic attrition; Kieval, Burns and Serdar (U.S. Pat. No. 8,060,206) describe an electrical pulse generator that stimulates a baroreceptor, increasing parasympathetic activity, in response to high blood pressure; Hlavka and Elliott (US 2010/0070004) describe an implantable electrical stimulator in communication with an afferent neural pathway of a carotid body chemoreceptor to control dyspnea

via electrical neuromodulation. More recently, Carotid Body Ablation (CBA) has been conceived for treating sympathetically mediated diseases.

SUMMARY

[0008] This disclosure is related to methods, devices, and systems for reducing afferent signaling between a peripheral chemoreceptor and the central nervous system. The disclosure includes methods, devices, and systems for directed energy ablation of a carotid body or its associated nerves. In particular, methods and devices for ablating tissue such as a carotid body, carotid septum or nerves associated with a carotid body that is proximate a vessel such as a vein or artery with an endovascular carotid body ablation (CBA) catheter having means for imaging and ablation.

[0009] A carotid body may be ablated by placing a directed energy emitter within or against the wall of an internal jugular vein or one of its tributaries adjacent to the carotid body of interest, then aiming and activating the directed energy emitter thereby raising the temperature of the perivenous space containing the carotid body or its nerves to an extent and duration sufficient to ablate tissue of a carotid septum, carotid body or its nerves.

[0010] In an exemplary procedure a location of perivenous space associated with a carotid body is identified, then a directed energy emitter is placed against or within the interior wall of an internal jugular vein adjacent to the identified location, then directed energy ablation parameters are selected and the directed energy emitter is activated thereby ablating the carotid body, whereby the orientation and position of the directed energy emitter and the selection of directed energy ablation parameters provides for ablation of the carotid body without substantial collateral damage to adjacent functional structures.

[0011] In a further exemplary procedure a location of extravascular space associated with a carotid body is identified, then a directed energy emitter is placed proximate to the identified location, then directed energy ablation parameters are selected and the directed energy emitter is activated thereby ablating the carotid body, whereby the position of the directed energy emitter and the selection of directed energy ablation parameters provides for ablation of the carotid body without substantial collateral damage to adjacent functional structures.

[0012] One aspect of the disclosure is an ultrasound ablation catheter configured to interact with an imaging catheter such as an intravascular ultrasound (“IVUS”) imaging catheter or an intracardiac echocardiography (ICE) catheter, the ultrasound ablation catheter comprising: a distal region and a proximal region; an Imaging catheter lumen to receive therethrough an imaging catheter extending from the proximal region to the distal region; an echolucent chamber at the distal region; and an ultrasound ablation transducer within the echolucent chamber, wherein the Imaging catheter lumen is configured to position the imaging catheter within a direction of aim of the ultrasound ablation transducer in a deployed state and out of the direction of aim in a retracted state.

[0013] One aspect of the disclosure is an ultrasound ablation catheter configured to interact with an ultrasound imaging catheter having an ultrasound imaging transducer, the ultrasound ablation catheter comprising: a distal region and a proximal region; an Imaging catheter lumen configured to receive therethrough an imaging catheter extending from the

proximal region to the distal region; an echolucent chamber at the distal region; and an ultrasound ablation transducer within the echolucent chamber, wherein the Imaging catheter lumen is configured to position the ultrasound imaging transducer of the imaging catheter distal to the ultrasound ablation transducer such that the ultrasound ablation transducer may deliver ablation energy while the ultrasound imaging transducer is transmitting and receiving waves to provide an image while ablating.

[0014] One aspect of the disclosure is an ultrasound ablation catheter, comprising: a distal assembly comprising an ultrasound ablation transducer, an echolucent shell, and an ablation direction fiducial marker, the echolucent shell at least partially defining a distal chamber, the ultrasound ablation transducer disposed within the distal chamber, the distal assembly adapted to house therein an ultrasound imaging transducer, the ablation direction fiducial marker positioned relative to the ultrasound ablation transducer and adapted to, when an ultrasound imaging transducer is positioned and activated within the distal assembly, create an aiming artifact on an image created by the ultrasound imaging transducer, the aiming artifact adapted to be used to indicate a direction of ablation; and an elongate shaft extending proximally from the distal assembly.

[0015] One aspect of the disclosure herein is an ultrasound ablation catheter, comprising: a distal assembly comprising an ultrasound ablation transducer and an echolucent shell, the echolucent shell at least partially defining a distal chamber, the ultrasound ablation transducer disposed within the distal chamber, the distal assembly adapted to house therein an ultrasound imaging transducer, wherein the echolucent shell has a first thickness at a first axial location of the ablation ultrasound transducer, and a second thickness greater than the first thickness at a second axial location distal to a distal end of the ablation ultrasound transducer; and an elongate shaft extending proximally from the distal assembly.

[0016] One aspect of the disclosure herein is an ultrasound ablation catheter, comprising: a distal assembly comprising an ultrasound ablation transducer and an echolucent shell, the echolucent shell at least partially defining a distal chamber, the ultrasound ablation transducer disposed within the distal chamber, the distal assembly adapted to house therein an ultrasound imaging transducer; a fluid lumen, the fluid lumen in fluid communication with the ultrasound ablation transducer, the fluid lumen also comprising an electrical connector in electrical communication with the ablation ultrasound transducer; and an elongate shaft extending proximally from the distal assembly.

[0017] One aspect of the disclosure herein is an ultrasound ablation catheter, comprising: a distal assembly comprising an ultrasound ablation transducer and an echolucent shell, the echolucent shell at least partially defining a distal chamber, the ultrasound ablation transducer disposed within the distal chamber, the distal assembly adapted to house therein an ultrasound imaging transducer; an elongate shaft extending proximally from the distal assembly; and an ablation transducer support secured to and extending distally from at least a portion the elongate shaft, the ablation ultrasound transducer mounted to the ablation transducer support.

[0018] In any of the ablation catheters herein the catheter can further comprise a cooling fluid lumen for cooling the therapeutic or ablation ultrasound transducer, which may be

contained in an echolucent chamber. Delivering fluid to a space around ultrasound transducer(s) furthermore provides an acoustic coupling medium. In any of the ablation catheters herein a direction of aim of the ultrasound ablation catheter can be in a radial direction from the catheter within an imaging plane generated by the Imaging catheter when in a deployed state. In any of the ablation catheters herein the catheter can further comprise a mating feature at the proximal region for coupling with the Imaging catheter wherein the mating feature is associated with an actuator that transitions the Imaging catheter between a deployed state and a retracted state. In any of the ablation catheters herein the catheter can be configured for controllable deflection of the distal region, wherein a plane of deflection is coplanar with the ultrasound ablation transducer. In any of the ablation catheters herein the catheter can further comprise a lumen configured to receive a guidewire.

[0019] In any of the ablation catheters herein the catheter can further comprise an acoustic insulator to shield passage of ultrasound ablation energy, wherein the acoustic insulator comprises microspheres of air embedded in epoxy. The acoustic insulator can have a thickness of about 200 to 300 microns and comprises microspheres having a diameter in a range of about 15 to 25 microns and microspheres having a diameter in a range of about 180 to 210 microns.

[0020] In any of the ablation catheters herein the catheter can further comprise a fiducial marker having a position with respect to the imaging transducer and the direction of aim of the ablation transducer. The fiducial marker can be a hollow tube filled with air. The fiducial marker can be axially aligned with the ultrasound imaging catheter when the ultrasound image transducer is in an active position in the distal assembly. The fiducial marker can be disposed relative to the ultrasound ablation transducer such that the direction of the ablation energy emitted from the ultrasound ablation transducer can be determined based on the location of the indicator on the image. The fiducial marker can be secured to the echolucent shell. The echolucent shell can comprise first and second membranes, and the fiducial marker can be secured between the first and second membranes. The fiducial marker has a curved configuration, such as a partial tubular member. The fiducial marker can be an extension of a support member disposed proximal to the ablation direction fiducial marker. The fiducial marker can be an echopaque material, such as stainless steel, or a radio-opaque material such as platinum-iridium.

[0021] In any of the ablation catheters herein the ablation catheter can be configured to be inserted through a jugular vein of a patient and wherein the ultrasound ablation transducer can be configured to be placed in proximity to a target ablation site including a carotid body.

[0022] In any of the ablation catheters herein the catheter can comprise a distal assembly further comprising a lumen therein configured to receive therethrough an ultrasound imaging catheter.

[0023] In any of the ablation catheters herein the ablation transducer can be a flat transducer with an axial axis that is parallel to the longitudinal axis of the elongate shaft in a straight configuration. A flat transducer can be disposed in an outer radial portion of the distal region of the catheter.

[0024] In any of the ablation catheters herein an echolucent shell can have a first thickness at a first axial location of the ablation ultrasound transducer, and a second thickness greater than the first thickness at a second axial location

distal to the ablation ultrasound transducer. The echolucent shell can comprise at least first and second membrane sections that are affixed together in the second axial location.

[0025] In any of the ablation catheters herein the catheter can further comprise a fluid lumen, the fluid lumen in fluid communication with the ultrasound ablation transducer, the fluid lumen also comprising an electrical connector in electrical communication with the ablation ultrasound transducer.

[0026] In any of the ablation catheters herein the catheter can further comprise a ablation transducer support secured to and extending distally from at least a portion the elongate shaft, and the ablation ultrasound transducer can be mounted to the ablation transducer support. The catheter can further comprise a plate secured between the ablation ultrasound transducer and the ablation transducer support. The ablation transducer support can comprise a lumen adapted to receive an ultrasound imaging catheter therein. The ablation transducer support can further comprise at least one fluid exit lumen in communication with a proximal region of the catheter. The ablation transducer support can comprise a recess defined by side edges and a back plate, the recess adapted to receive therein the ultrasound ablation transducer, wherein the ablation transducer is secured within the recess such that the side edges extend radially outward relative to the ablation transducer to allow the free flow of cooling fluid over the ablation transducer.

[0027] The ablation transducer support can be configured to induce turbulent flow of cooling fluid over the ablation transducer.

[0028] One aspect of the disclosure is a method in a computer system, comprising: receiving as input an ultrasound-based image, the ultrasound-based image derived from signals received from an ultrasound imaging transducer; determining the location of an artifact in the ultrasound-based image, the artifact having been created by a fiducial marker on an ultrasound ablation transducer in response to ultrasound waves generated by the ultrasound imaging transducer; based on the location of the artifact, determining a direction of aim of ablation energy from the ultrasound ablation transducer; and creating an augmented ultrasound-based image as output for display on a monitor, the augmented ultrasound-based image including the ultrasound-based image and the direction of aim of the of ablation energy from the ultrasound ablation transducer.

[0029] One aspect of the disclosure is a computer-implemented method comprising: receiving a video or ultrasound-based image of a target ablation site for carotid body ablation created from ultrasound signals transmitted from an ultrasound transceiver, the video or ultrasound-based image having been captured while an ultrasound ablation transducer is located proximate to the target ablation site for carotid body ablation; augmenting the video or ultrasound-based image by one or more visual aids, animations or messages, wherein the one or more visual aids, animations or messages include information regarding a direction of aim of ablation energy from the ultrasound ablation transducer for carotid body ablation; and displaying the augmented video or ultrasound-based image on a user interface.

[0030] One aspect of the disclosure is a computer-implemented method comprising: receiving a video or ultrasound-based image of a target ablation site for carotid body ablation created from ultrasound signals transmitted from an ultrasound transceiver, the video or ultrasound-based image

having been captured while an ultrasound ablation transducer is located proximate to the target ablation site for carotid body ablation; augmenting the video or ultrasound-based image by one or more visual aids, animations or messages, wherein the one or more visual aids, animations or messages include information regarding an estimated location of an ablation area of an ultrasound ablation transducer being located proximate to the target ablation site for carotid body ablation; and displaying the augmented video or ultrasound-based image on a user interface.

[0031] One aspect of the disclosure is a system for imaging and ablation of a carotid body having image augmentation comprising: a catheter with an ultrasound imaging transducer and an ablation element; an ablation console; an ultrasound imaging console configured for transmitting and receiving signals to and from the imaging transducer; a computer executed algorithm that creates an ultrasound-based image from signals received from the imaging transducer; an image augmentation unit that processes the ultrasound-based image with a computer algorithm that creates an augmented image; and a monitor to display the augmented image.

[0032] In any of the methods or systems herein that can create and/or display an augmented video or ultrasound-based image, determining a location of an artifact in the ultrasound-based image can comprise recognizing a portion of the ultrasound-based image that substantially does not change shape when the orientation of the ultrasound-based image changes in response to movement of the ultrasound imaging transducer.

[0033] In any of the methods or systems herein that can create and/or display an augmented video or ultrasound-based image, one or more visual aids, animations or messages can include information regarding an estimated location of an ablation area of the ultrasound ablation transducer.

[0034] In any of the methods or systems herein that can create and/or display an augmented video or ultrasound-based image, information regarding an estimated location of an ablation area can include a direction in which the ultrasound ablation transducer is facing and/or a direction in which the ultrasound ablation transducer will deliver ablation energy.

[0035] In any of the methods or systems herein that can create and/or display an augmented video or ultrasound-based image, information regarding an estimated location of an ablation area can include an estimated depth and/or width of an ablation area of the ultrasound ablation transducer.

[0036] In any of the methods or systems herein that can create and/or display an augmented video or ultrasound-based image, information regarding an estimated location of an ablation area can include an estimated outline of the ablation area.

[0037] In any of the methods or systems herein that can create and/or display an augmented video or ultrasound-based image, information regarding an estimated location of an ablation area of an ultrasound ablation transducer can be determined by taking into account user defined and/or automatically set parameters of an ablation procedure.

[0038] In any of the methods or systems herein that can create and/or display an augmented video or ultrasound-based image, an estimated location of an ablation area of an ultrasound ablation transducer can be determined at least partially based on a selected ablation energy profile.

[0039] In any of the methods or systems herein that can create and/or display an augmented video or ultrasound-based image, an estimated location of an ablation area of an ultrasound ablation transducer can be determined by taking into account one or more anatomical parameters of a candidate for ablation treatment.

[0040] In any of the methods or systems herein that can create and/or display an augmented video or ultrasound-based image, an estimated location of an ablation area of an ultrasound ablation transducer can be determined by taking into account information regarding ablation properties of a specific type of catheter carrying the ultrasound ablation transducer.

[0041] In any of the methods or systems herein that can create and/or display an augmented video or ultrasound-based image, information regarding ablation properties of a type of a catheter carrying the ultrasound ablation transducer can include information correlating an estimated lesion depth and/or width with ablation energy and duration for the specific type of catheter.

[0042] In any of the methods or systems herein that can create and/or display an augmented video or ultrasound-based image, one or more visual aids, animations or messages can further include information regarding a direction of aim of ablation energy from an ultrasound ablation transducer for carotid body ablation.

[0043] In any of the methods or systems herein that can create and/or display an augmented video or ultrasound-based image, information regarding the direction of aim of ablation energy from the ultrasound ablation transducer for carotid body ablation can be determined by using a position of a fiducial marker or an aiming artifact in a video or ultrasound-based image.

[0044] In any of the methods or systems herein that can create and/or display an augmented video or ultrasound-based image, a fiducial marker can be arranged in a pre-defined position relative to the direction of aim of an ablation catheter carrying the ultrasound ablation transducer.

[0045] In any of the methods or systems herein that can create and/or display an augmented video or ultrasound-based image, a fiducial marker can include a band or tube of echo-opaque material or structure or a structure having distinctly hyperechoic or hypoechoic material or structure compared to surrounding structures and/or surrounding tissue when located proximate to the target ablation site.

[0046] In any of the methods or systems herein that can create and/or display an augmented video or ultrasound-based image, a fiducial marker can include a piezoelectric element.

[0047] In any of the methods or systems herein that can create and/or display an augmented video or ultrasound-based image, a fiducial marker is positioned on an ablation catheter carrying the ultrasound ablation transducer to indicate on an ultrasound-based image the opposite direction of delivery of ablation energy.

[0048] In any of the methods or systems herein that can create and/or display an augmented video or ultrasound-based image, information regarding the direction of aim of ablation energy from the ultrasound ablation transducer for carotid body ablation can be determined by using a position of multiple fiducial markers or aiming artifacts in a video or ultrasound-based image.

[0049] In any of the methods or systems herein that can create and/or display an augmented video or ultrasound-

based image, a video or ultrasound-based image can be created with an ultrasound imaging catheter such as an IVUS catheter or an ICE catheter.

[0050] In any of the methods or systems herein that can create and/or display an augmented video or ultrasound-based image, an ultrasound imaging catheter can be placed in a jugular vein of a candidate for carotid body ablation in proximity to a carotid bifurcation.

[0051] Any of the methods or systems herein that can create and/or display an augmented video or ultrasound-based image can further comprise determining a scale of the video or ultrasound-based image based of a known dimension of a catheter or aiming artifact visible in the video or ultrasound-based image.

[0052] In any of the methods or systems herein that can create and/or display an augmented video or ultrasound-based image, one or more visual aids, animations or messages can include information of one or more distances between anatomical features of the target ablation site.

[0053] In any of the methods or systems herein that can create and/or display an augmented video or ultrasound-based image, one or more distances can include one or more of a relative position of an internal jugular vein, a carotid septum, an internal carotid artery, an external carotid artery, or carotid septum boundaries to a reference point, artery diameters, changes in artery diameters, changes in relative position of anatomical features, size and relative position of an estimated ablation or created ablation.

[0054] Any of the methods or systems herein that can create and/or display an augmented video or ultrasound-based image can further comprise providing a user with ablation therapy instructions or suggestions based on the one or more distances between anatomical features of the target ablation site.

[0055] One aspect of the disclosure is a computer system for monitoring a carotid ablation procedure being configured to perform the operations of any of the methods herein. The computer systems can comprise a display configured to display augmented video or ultrasound-based image and an input interface configured for receiving the video or ultrasound-based image from an ultrasound imaging device. A computer readable medium can include instructions which when executed by a computer system let the computer system carry out the operations of any of the methods herein.

[0056] In any of the methods or systems herein that can create and/or display an augmented video or ultrasound-based image, an augmented image can be overlaid on the ultrasound-based image and indicates the direction of delivery of ablation energy, carotid arteries, an estimated ablation outline, estimated ablation depth, and estimated created ablation positions. A computer algorithm can control the ablation console using calculations of relative positions of estimated ablation position and carotid arteries.

[0057] One aspect of the disclosure a computer implemented method for determining parameters for a carotid body ablation procedure, the method comprising: receiving information characterizing a dimension of a desired ablation volume of an ultrasound carotid body ablation procedure; and automatically determining one or more ultrasound ablation delivery parameters based on the received information; and providing as output to an ultrasound ablation delivery system the delivery parameters.

[0058] One aspect of the disclosure is a method in a computer system, comprising: receiving as input a distance,

measured from an ultrasound-based image derived from a signal received from an ultrasound transducer positioned in a jugular vein, from a wall of a jugular vein to a line connecting portions of an internal and external carotid arteries; determining ultrasound ablation delivery parameters based on the input distance; and providing as output to an ultrasound ablation delivery system the delivery parameters.

[0059] In any of the methods or systems herein that can determine parameters for a carotid body ablation procedure, one or more ultrasound ablation delivery parameters can include an ablation energy profile to be used by the ablation delivery system.

[0060] In any of the methods or systems herein that can determine parameters for a carotid body ablation procedure, an ablation energy profile can specify a profile of an amount of acoustic power and duration of delivery of the ablation energy during a treatment procedure.

[0061] In any of the methods or systems herein that can determine parameters for a carotid body ablation procedure, one or more ultrasound ablation delivery parameters can be determined by taking into account one or more anatomical parameters of a candidate for ablation treatment.

[0062] In any of the methods or systems herein that can determine parameters for a carotid body ablation procedure, one or more ultrasound ablation delivery parameters can be determined by taking into account information regarding ablation transducer properties of a specific catheter carrying the ultrasound ablation transducer.

[0063] In any of the methods or systems herein that can determine parameters for a carotid body ablation procedure, information regarding ablation transducer properties of a catheter carrying the ultrasound ablation transducer can include information correlating an estimated lesion depth and/or width with electrical power and duration for the specific ablation catheter.

[0064] In any of the methods or systems herein that can determine parameters for a carotid body ablation procedure, a desired ablation volume of an ultrasound carotid body ablation procedure can be automatically determined based on a video or ultrasound-based image created from ultrasound signals transmitted from an ultrasound transducer of a target ablation site for carotid body ablation.

[0065] In any of the methods or systems herein that can determine parameters for a carotid body ablation procedure, an automatic determination can include assessing position or size of one or more anatomic features in the target ablation site.

[0066] In any of the methods or systems herein that can determine parameters for a carotid body ablation procedure, one or more anatomic features can include a carotid septum, a carotid body, internal and external carotid arteries and a jugular vein.

[0067] In any of the methods or systems herein that can determine parameters for a carotid body ablation procedure, determining one or more ultrasound ablation delivery parameters can include using information retrieved from prior ablation procedures and/or evaluation of numerical models of simulation procedures.

[0068] Any of the methods or systems herein that can determine parameters for a carotid body ablation procedure can further include automatically monitoring a movement of a patient's body or head; identifying a movement that meets a predetermined significance criterion indicating a risk for

the patient; and generating a signal indicating that a movement has met a predetermined significance criterion.

[0069] In any of the methods or systems herein that can determine parameters for a carotid body ablation procedure, one or more ultrasound ablation delivery parameters can include duration of energy delivery and acoustic power, wherein the acoustic power is in a range between 2 watts and 25 watts and the duration is in a range between 3 seconds and 25 seconds.

[0070] One aspect of the disclosure is a computer system for monitoring a carotid ablation procedure being configured to perform the operations of any one of the methods herein. A computer readable medium can include instructions which when executed by a computer system let the computer system carry out the operations of any of the methods herein.

[0071] One aspect of the disclosure is an ultrasound ablation catheter that includes an insulating member engaging at least one surface of the ablation transducer, the insulating member electrically isolating at least one pole of the ablation transducer from conductive fluid in the echolucent chamber.

[0072] One aspect of the disclosure is an ultrasound ablation catheter that includes a cooling fluid inlet port proximal to the ablation transducer and a cooling fluid exit port distal to the ablation transducer.

[0073] One aspect of the disclosure is an ultrasound ablation catheter that includes a membrane (e.g., extending over an outer surface of the ablation transducer support at least one of proximal and distal ends of the ablation transducer support). In one aspect, the ultrasound ablation catheter includes a membrane (e.g., extending over an outer surface of the ablation transducer support at least one of proximal and distal ends of the ablation transducer support) in combination with an insulating member engaging at least one surface of the ablation transducer, the insulating member electrically isolating at least one pole of the ablation transducer from conductive fluid in the echolucent chamber

[0074] One aspect of the disclosure is an ultrasound ablation catheter that includes an ablation transducer support.

[0075] One aspect of the disclosure is an ultrasound ablation catheter that includes a plurality of ultrasound imaging transducers (e.g., three or more ultrasound imaging transducers) disposed at least partly around the circumference of the catheter. In one aspect, the ultrasound ablation catheter that includes a plurality of ultrasound imaging transducers (e.g., three or more ultrasound imaging transducers) disposed at least partly around the circumference of the catheter in combination with an insulating member engaging at least one surface of the ablation transducer, the insulating member electrically isolating at least one pole of the ablation transducer from conductive fluid in the echolucent chamber and/or in combination with a membrane (e.g., extending over an outer surface of the ablation transducer support at least one of proximal and distal ends of the ablation transducer support). One aspect of the disclosure is an ultrasound ablation catheter that includes a recessed region within the cross-section of the ultrasound ablation catheter. In one aspect, the wherein the ultrasound ablation transducer is arranged within a recessed region and the ultrasound imaging transducer is not arranged within the recessed region.

[0076] One aspect of the disclosure is an ultrasound ablation catheter that includes an ultrasound imaging transducer that is carried by an external catheter shaft surface.

[0077] One aspect of the disclosure is an ultrasound ablation catheter that includes an ultrasound imaging transducer

or a plurality of ultrasound imaging transducers that are proximal relative to an ultrasound ablation transducer.

[0078] One aspect of the disclosure is an ultrasound ablation catheter that includes a guidewire lumen disposed behind the ablation transducer, opposite the direction of aim of the ablation transducer. In one aspect, ultrasound ablation catheter that includes a guidewire lumen disposed behind the ablation transducer, opposite the direction of aim of the ablation transducer in combination with a plurality of ultrasound imaging transducers (e.g., three or more ultrasound imaging transducers) disposed at least partly around the circumference of the catheter and an insulating member engaging at least one surface of the ablation transducer, the insulating member electrically isolating at least one pole of the ablation transducer from conductive fluid in the echolucent chamber.

[0079] One aspect of the disclosure is an ultrasound ablation catheter that includes an ablation transducer that has a width, and the catheter has a catheter diameter, wherein the ratio of the catheter diameter to the width is no more than 2.5.

[0080] One aspect of the disclosure is an ultrasound ablation catheter that includes an imaging transducer, further comprising a radiopaque marker overlapping the imaging transducer, in a side view.

[0081] One aspect of the disclosure is an ultrasound ablation catheter and a sheath in which the catheter is disposed, the sheath comprising a sheath radiopaque marker on a distal region.

[0082] One aspect of the disclosure is an ultrasound ablation catheter that includes a radiopaque cap on a distal region of the catheter.

[0083] One aspect of the disclosure is an ultrasound ablation catheter that includes an imaging transducer or a plurality of transducers configured to generate an image of a plane of tissue that is about 1 to 15 mm, optionally about 3 to 12 mm from a center of the transmitting face of an ablation transducer.

[0084] One aspect of the disclosure is an ultrasound ablation catheter that is adapted such that it can be delivered without the use of a delivery sheath, the catheter further comprising a deflectable section proximal to the ultrasound imaging transducer and the ultrasound ablation transducer.

[0085] One aspect of the disclosure is a medical device that is adapted for limited use, wherein the medical device is not limited to those described herein but can be any medical device that can receive a signal from a console. The medical device can be adapted to indicate if the device has received a signal, optionally electrical, from a console. The medical device can also be adapted to indicate if a specified amount of time has passed since the device stopped receiving a signal from the console (e.g., if the medical device was unplugged from the console or if the console was shut off). As an example, the medical device can include a non-volatile memory storage (e.g., EEPROM) with a bit that is set if the device has ever received a signal from the console (e.g., from being plugged into the console). The digital memory storage can include a second bit that is set if the specified amount of time has passed after energy from the console to the device is discontinued. If the medical device is plugged into the same or different console again (or the console is turned on after being turned off with device still plugged in), the console can be adapted to read the digital memory storage, and if both bits are set, the console can

prevent the medical device from being used, such as by preventing a signal from being sent from the console to the medical device. The medical device can also be adapted to indicate only if a specified amount of time has passed since the device stopped receiving a signal from the console, even if the medical device is not adapted to indicate if the device has received a signal from the console. The disclosure also includes consoles that can read a memory in a medical device to determine if a specified period of time has passed since the medical device was receiving a signal from a console. If the console determines that the specified period of time has passed, the console can be adapted to prevent a signal from being sent to the medical device, thus preventing it from being used. For example, the console can read a digital memory storage on a medical device and determine if a bit has been set as a result of a specific period of time passing after the medical device received a signal from a console.

BRIEF DESCRIPTION OF THE DRAWINGS

[0086] FIG. 1 depicts in simplified schematic form a placement of an endovascular directed energy ablation catheter into a patient via a femoral vein puncture.

[0087] FIG. 2 is a schematic illustration of a cross section through an intercarotid septum and surrounding tissues showing some characteristic dimensions.

[0088] FIGS. 3A, 3B, 3C, 3D, and 3E are schematic illustrations of embodiments of an ultrasound transducer.

[0089] FIGS. 4A and 4B are schematic illustrations of an ultrasound CBA catheter delivered to an internal jugular vein.

[0090] FIGS. 5A, 5B, 6A, 6B, 7A, 7B, 7C, 8A, 8B, 8C, and 8D are schematic illustrations of an ultrasound CBA catheter having one or more diagnostic catheters used to align with vascular landmarks delivered to an internal jugular vein.

[0091] FIGS. 9A and 9B are schematic illustrations of an ultrasound CBA catheter with an adjustable focus distance.

[0092] FIG. 10 is a schematic illustration of an ultrasound CBA catheter with an adjustable focus distance.

[0093] FIG. 11 is a schematic illustration of an ultrasound CBA catheter configured to accept a separate ultrasound imaging catheter.

[0094] FIGS. 12A, 12B, 12C, 12D, 12E, 12F, 12G, 12H and 12I are schematic illustrations of an ultrasound CBA catheter configured to accept a separate ultrasound imaging catheter.

[0095] FIG. 13 is a schematic illustration of an ultrasound CBA catheter configured to accept a separate ultrasound imaging catheter.

[0096] FIGS. 14A and 14B are schematic illustrations of an ultrasound CBA catheter configured to accept a separate ultrasound imaging catheter.

[0097] FIG. 15A is a schematic illustration of a component of a catheter shown in FIG. 15B.

[0098] FIG. 15B is a schematic illustration of an ultrasound CBA catheter configured to accept a separate ultrasound imaging catheter.

[0099] FIG. 16 is a schematic illustration of an ultrasound image generated during a transvenous carotid body ablation procedure.

[0100] FIG. 17 is a schematic illustration of a deflectable ultrasound catheter

[0101] FIG. 18 is a schematic illustration of an ultrasound CBA catheter configured to accept a separate ultrasound imaging catheter.

[0102] FIG. 19 is a schematic illustration of an ultrasound CBA catheter configured to accept a separate ultrasound imaging catheter.

[0103] FIGS. 20A and 20B are schematic illustrations of an ultrasound CBA catheter configured to accept a separate ultrasound imaging catheter.

[0104] FIGS. 21A, 21B, and 21C are schematic illustrations of a CBA catheter and deflectable sheath manipulating a position of a vein.

[0105] FIG. 22A is a schematic illustration of a transducer assembly configured for ablation and imaging.

[0106] FIG. 22B is a table of electrode and frequency configuration for ablation and imaging modes of a transducer assembly shown in FIG. 22A.

[0107] FIG. 23 is a schematic illustration of a catheter comprising a transducer assembly configured for both imaging and ablation.

[0108] FIGS. 24A, 24B, are plots of lesion depth vs energy.

[0109] FIGS. 24Ci, 24Cii, 24Ciii, and 24Civ represent data from an example of an algorithm to determine dosimetry for a unique catheter.

[0110] FIG. 25 is a lesion dosimetry lookup table.

[0111] FIG. 26 is a frame of an ultrasound-based video taken by a catheter placed in a jugular vein proximate a carotid bifurcation.

[0112] FIG. 27 is a block diagram of a system for imaging and ablation.

[0113] FIGS. 28, 29, 30 and 31 are schematic illustrations of augmented ultrasound-based videos.

[0114] FIG. 32 is a schematic illustration of an ultrasound image guided needle ablation catheter.

[0115] FIG. 33 is a schematic illustration of an ultrasound image guided needle ablation catheter.

[0116] FIGS. 34A, 34B, 34C, 35, and 36 are schematic illustrations of ultrasound CBA catheters with an integrated ultrasound imaging transducer array.

[0117] FIG. 37A is a schematic illustration of an ultrasound-based video taken from a jugular vein proximate a carotid septum.

[0118] FIG. 37B is a schematic illustration of an ultrasound-based video taken from a jugular vein proximate a carotid septum showing an aiming emission from an ablation transducer.

[0119] FIG. 37C is a schematic illustration of an ultrasound-based video taken from a jugular vein proximate a carotid septum showing an aiming emission from an ablation transducer.

[0120] FIG. 38 is a schematic illustration of an ultrasound CBA catheter with an integrated ultrasound imaging transducer.

[0121] FIG. 39 is a schematic illustration of an ultrasound CBA catheter having multiple deflectable sections configured for deflection in multiple directions.

[0122] FIG. 40 is a schematic illustration of an ultrasound CBA catheter having multiple deflectable sections configured for deflection at different positions along the length of the catheter.

[0123] FIGS. 41A, 41B, and 41C are schematic illustrations of an ultrasound CBA catheter having a passively flexible section configured with an adjustable length.

[0124] FIG. 42 is a schematic illustration of an ultrasound CBA catheter comprising an integrated sheath.

[0125] FIGS. 43A, 43B, 43C, and 43D are schematic illustrations of ultrasound CBA catheters having a protective covering.

[0126] FIGS. 44A, 44B, and 44C are schematic illustrations of ablation transducers configured to be cooled with saline solution.

[0127] FIGS. 45A, 45B, 45C, 45D, and 45E are schematic illustrations of an ablation catheter and system having an integrated imaging array.

[0128] FIG. 46A is a simplified circuit diagram of a use limiter.

[0129] FIGS. 46B and 46C are flowcharts of use limiter algorithms.

DETAILED DESCRIPTION

[0130] The disclosure herein is related to systems, devices, and methods for carotid body ablation to treat patients having a sympathetically mediated disease (e.g., cardiac, renal, metabolic, or pulmonary disease such as hypertension, CHF, sleep apnea, sleep disordered breathing, diabetes, insulin resistance, asthma, COPD) at least partially resulting from augmented peripheral chemoreflex (e.g., peripheral chemoreceptor hypersensitivity, peripheral chemosensor hyperactivity) or heightened sympathetic activation. Carotid body ablation as used herein refers generally to completely or partially ablating one or both carotid bodies, carotid body nerves, intercarotid septums, or peripheral chemoreceptors. A main therapy pathway is a reduction of peripheral chemoreflex or reduction of afferent nerve signaling from a carotid body (CB), which results in a reduction of central sympathetic tone. Higher than normal chronic or intermittent activity of afferent carotid body nerves is considered enhanced chemoreflex for the purpose of this application regardless of its cause. Other important benefits such as increase of parasympathetic tone, vagal tone and specifically baroreflex and baroreceptor activity reduction of dyspnea, hyperventilation and breathing rate may be expected in some patients. Secondary to reduction of breathing rate additional increase of parasympathetic tone may be expected in some cases. Augmented peripheral chemoreflex (e.g., carotid body activation) leads to increases in sympathetic nervous system activity, which is in turn primarily responsible for the progression of chronic disease as well as debilitating symptoms and adverse events seen in the intended patient populations. Carotid bodies contain cells that are sensitive to oxygen and carbon dioxide. Carotid bodies also respond to blood flow, blood pH, blood glucose level and possibly other variables. Thus, carotid body ablation may be a treatment for patients, for example having hypertension, heart disease or diabetes, even if chemosensitive cells are not activated.

Targets:

[0131] To inhibit or suppress a peripheral chemoreflex, anatomical targets for ablation (also referred to as targeted tissue, target ablation sites, or target sites) may include at least a portion of at least one carotid body, an aortic body, nerves associated with a peripheral chemoreceptor (e.g., carotid body nerves, carotid sinus nerve, carotid plexus), small blood vessels feeding a peripheral chemoreceptor, carotid body parenchyma, chemosensitive cells (e.g., glomus cells), tissue in a location where a carotid body is

suspected to reside (e.g., a location based on pre-operative imaging or anatomical likelihood), an intercarotid septum, a portion of an intercarotid septum, a substantial part of an intercarotid septum or a combination thereof. As used herein, ablation of a carotid body may refer to ablation of any of these target ablation sites.

[0132] An intercarotid septum, which is also referred to herein as a carotid septum, is herein defined as a wedge or triangular segment of tissue with the following boundaries: a saddle of a carotid bifurcation defines a caudal aspect (i.e., an apex) of a carotid septum; facing walls of internal and external carotid arteries define two sides of the carotid septum; a cranial boundary of a carotid septum extends between these arteries and may be defined as cranial to a carotid body but caudal to any important non-target nerve structures (e.g., a hypoglossal nerve) that might be in the region, for example a cranial boundary may be about 10 mm to about 15 mm from the saddle of the carotid bifurcation; medial and lateral walls of the carotid septum are generally defined by planes approximately tangent to the internal and external carotid arteries; one of the planes is tangent to the lateral walls of the internal and external carotid arteries and the other plane is tangent to the medial walls of these arteries. An intercarotid septum is disposed between the medial and lateral walls. An intercarotid septum may contain, completely or partially, a carotid body and may be absent of important non-target structures such as a vagus nerve or sympathetic nerves or a hypoglossal nerve. An intercarotid septum may include some baroreceptors or baroreceptor nerves. An intercarotid septum may also include intercarotid plexus nerves, small blood vessels and fat. An intercarotid septum may be a target for ablation. Even if a carotid body or carotid body nerve cannot be easily identified visually to target specifically an intercarotid septum may be targeted with a high probability of ablating a carotid body and safely avoiding non-target nerves. Multiple ablations may be created within a carotid septum to cover an increased volume of tissue to increase a probability of ablating a carotid body. Multiple ablations may overlap or be discrete within a carotid septum.

[0133] Carotid body nerves are anatomically defined herein as carotid plexus nerves and carotid sinus nerves. Carotid body nerves are functionally defined herein as nerves that conduct information from a carotid body to a central nervous system. Carotid body nerves can be referred to herein as one or more nerves that are associated with the carotid body.

[0134] An ablation may be focused exclusively on targeted tissue, or be focused on the targeted tissue while safely ablating tissue proximate to the targeted tissue (e.g., to ensure the targeted tissue is ablated or as an approach to gain access to the targeted tissue). An ablation region may be as big as a peripheral chemoreceptor (e.g., carotid body or aortic body) itself, somewhat smaller, or bigger and can include one or more tissues surrounding the chemoreceptor such as blood vessels, adventitia, fascia, small blood vessels perfusing the chemoreceptor, and nerves connected to and innervating the glomus cells. An intercarotid plexus or carotid sinus nerve may be a target of ablation with an understanding that some baroreceptor nerves will be ablated together with carotid body nerves. Baroreceptors are distributed in the human arteries and have a high degree of redundancy.

[0135] Tissue may be ablated to inhibit or suppress a chemoreflex of only one of a patient's two carotid bodies. Other embodiments include ablating tissue to inhibit or suppress a chemoreflex of both of a patient's carotid bodies. In some embodiments an ablation is performed on a first carotid body, and an assessment is then performed to determine if the other carotid body should be ablated. For example, a therapeutic method may include ablation of one carotid body, measurement of resulting chemosensitivity, sympathetic activity, respiration or other parameter related to carotid body hyperactivity, and ablation of the second carotid body can be performed if desired to further reduce chemosensitivity following the unilateral ablation.

[0136] An embodiment of a therapy may substantially reduce chemoreflex without excessively reducing the baroreflex of the patient. The proposed ablation procedure may be targeted to substantially spare the carotid sinus, baroreceptors distributed in the walls of carotid arteries, particularly internal carotid arteries, and at least some of the carotid sinus nerves that conduct signals from said baroreceptors. For example, the baroreflex may be substantially spared by targeting a limited volume of ablated tissue possibly enclosing the carotid body, tissues containing a substantial number of carotid body nerves, tissues located in periaortic space of a medial segment of a carotid bifurcation, or tissue located at the attachment of a carotid body to an artery. Said targeted ablation is enabled by visualization of the area or carotid body itself, for example by CT, CT angiography, MRI, ultrasound sonography, fluoroscopy, blood flow visualization, or injection of contrast, and positioning of an instrument in the carotid body or in close proximity while avoiding excessive damage (e.g., perforation, stenosis, thrombosis) to carotid arteries, baroreceptors, carotid sinus nerves or other important non-target nerves such as a vagus nerve or sympathetic nerves located primarily outside of the carotid septum. Thus imaging a carotid body before ablation may be instrumental in (a) selecting candidates if a carotid body is present, large enough and identified and (b) guiding therapy by providing a landmark map for an operator to guide an ablation instrument to the carotid septum, center of the carotid septum, carotid body nerves, the area of a blood vessel proximate to a carotid body, or to an area where carotid body itself or carotid body nerves may be anticipated. It may also help exclude patients in whom the carotid body is located substantially outside of the carotid septum in a position close to a vagus nerve, hypoglossal nerve, jugular vein or some other structure that can be endangered by ablation. In one embodiment only patients with a carotid body substantially located within the intercarotid septum are selected for ablation therapy.

[0137] An embodiment of a method of treatment may comprise only ablating one of the right and left carotid bodies. Compared to ablating both carotid bodies, this may reduce procedure time and cost and safety risk while resulting in a desired therapeutic effect. Furthermore, patients having only one accessible carotid body, for example due to vascular disease or abnormalities, may be candidates for a procedure. When performing a one-sided treatment there may be advantages of ablating the right side carotid body over the left. For example, the right side may be easier, faster, or safer to approach or may have a greater therapeutic effect than the left side.

[0138] Once a carotid body is ablated, removed or denervated, the carotid body function (e.g., carotid body chemoreflex) does not substantially return in humans, partly because in humans aortic chemoreceptors are considered undeveloped. To the contrary, once a carotid sinus baroreflex is removed it is generally compensated, after weeks or months, by the aortic or other arterial baroreceptor baroreflex. Thus, if both the carotid chemoreflex and baroreflex are removed or substantially reduced, for example by interruption of the carotid sinus nerve or intercarotid plexus nerves, the baroreflex may eventually be restored while the chemoreflex may not. The consequences of temporary removal or reduction of the baroreflex can be in some cases relatively severe and require hospitalization and management with drugs, but they generally are not life threatening, terminal or permanent. Thus, it is understood that while selective removal of carotid body chemoreflex with baroreflex preservation may be desired, it may not be absolutely necessary in some cases.

Ablation:

[0139] The term “ablation” may refer to the act of altering a tissue to suppress or inhibit its biological function or ability to respond to stimulation permanently or for an extended period of time (e.g., greater than 3 weeks, greater than 6 months, greater than a year, for several years, or for the remainder of the patient’s life). Selective denervation may involve, for example, interruption of afferent nerves from a carotid body while substantially preserving nerves from a carotid sinus, which conduct baroreceptor signals, and other adjacent nerves such as hypoglossal, laryngeal, and vagal nerves. Another example of selective denervation may involve interruption of a carotid sinus nerve, or intercarotid plexus which is in communication with both a carotid body and some baroreceptors wherein chemoreflex from the carotid body is reduced permanently or for an extended period of time (e.g., years) and baroreflex is substantially restored in a short period of time (e.g., days or weeks). As used herein, the term “ablate” or a derivative thereof refers to interventions that suppress or inhibit natural chemoreceptor or afferent nerve functioning, which is in contrast to electrically neuromodulating or reversibly deactivating and reactivating chemoreceptor functioning.

[0140] Carotid Body Ablation (“CBA”) as used herein refers to ablation of a target tissue wherein the desired effect is to reduce or remove the afferent neural signaling from a chemosensor (e.g., carotid body) or reducing a chemoreflex. Chemoreflex or afferent nerve activity cannot be directly measured in a practical way, thus indexes of chemoreflex such as chemosensitivity can sometimes be used instead. Chemoreflex reduction is generally indicated by a reduction of blood pressure, a reduction of an increase of ventilation and ventilation effort per unit of blood gas concentration, saturation or partial pressure change or by a reduction of central sympathetic nerve activity that can be measured indirectly. Sympathetic nerve activity can be assessed by reduction of blood pressure, measuring activity of peripheral nerves leading to muscles (MSNA), heart rate (HR), heart rate variability (HRV), production of hormones such as renin, epinephrine and angiotensin, and peripheral vascular resistance. All these parameters are measurable and can lead directly to the health improvements. In the case of CHF patients blood pH, blood PCO₂, degree of hyperventilation and metabolic exercise test parameters such as peak VO₂,

and VE/VCO₂ slope are also important. It is believed that patients with heightened chemoreflex have low VO₂ and high VE/VCO₂ slope (index of respiratory efficiency) as a result of, for example, tachypnea and low blood CO₂. These parameters are also related to exercise limitations that further speed up a patient’s status deterioration towards morbidity and death. It is understood that all these indexes are indirect and imperfect and intended to direct therapy to patients that are most likely to benefit or to acquire an indication of technical success of ablation rather than to prove an exact measurement of effect or guarantee a success. It has been observed that some tachyarrhythmias in cardiac patients are sympathetically mediated. Thus carotid body ablation may be instrumental in treating reversible atrial fibrillation and ventricular tachycardia.

[0141] Carotid body ablation may include methods and systems for the thermal ablation of tissue via thermal heating mechanisms. Thermal ablation may be achieved due to a direct effect on tissues and structures that are induced by the thermal stress. Additionally or alternatively, the thermal disruption may at least in part be due to alteration of vascular or peri-vascular structures (e.g., arteries, arterioles, capillaries or veins), which perfuse the carotid body and neural fibers surrounding and innervating the carotid body (e.g., nerves that transmit afferent information from carotid body chemoreceptors to the brain). Additionally or alternatively thermal disruption may be due to a healing process, fibrosis, or scarring of tissue following thermal injury, particularly when prevention of regrowth and regeneration of active tissue is desired. As used herein, thermal mechanisms for ablation may include both thermal necrosis or thermal injury or damage (e.g., via sustained heating, convective heating, resistive heating, or any combination thereof). Thermal heating mechanisms may include raising the temperature of target tissue, such as neural fibers, chemosensitive cells, all or a substantial number of carotid body cells, and small blood vessels perfusing the carotid body or its nerves, above a desired threshold, for example, above a body temperature of about 37° C. e.g., to achieve thermal injury or damage, or above a temperature of about 45° C. (e.g., above about 60° C.) to achieve thermal necrosis for a duration of time known to induce substantially irreversible ablation at the resulting temperature.

[0142] In addition to raising temperature during thermal ablation, a length of exposure to thermal stimuli may be specified to affect an extent or degree of efficacy of the thermal ablation. In some embodiments the length of exposure to thermal stimuli is between about 1 and about 60 seconds, such as between about 5 and about 30 seconds. In some embodiments the length of exposure to thermal stimuli can be, longer than or equal to about 30 seconds, or even longer than or equal to about 2 minutes. Furthermore, the length of exposure can be less than or equal to about 10 minutes, though this should not be construed as the upper limit of the exposure period. A temperature threshold, or thermal dosage, may be determined as a function of the duration of exposure to thermal stimuli. Additionally or alternatively, the length of exposure may be determined as a function of the desired temperature threshold. These and other parameters may be specified or calculated to achieve and control desired thermal ablation. Thermally-induced ablation may be achieved via indirect generation or application of thermal energy to the target tissue, such as neural fibers, chemosensitive cells, and all or a substantial number

of carotid body cells, such as through application of high-intensity focused ultrasound (HIFU), partially focused ultrasound, or high intensity directed ultrasound, to the target neural fibers.

[0143] Carotid body ablation may comprise delivering an agent systemically and directing energy such as ultrasound energy to the carotid body or associated nerves to activate the agent causing impairment of the carotid body or associated nerves.

[0144] Additional and alternative methods and apparatuses may be utilized to achieve ablation.

Directed Energy Embodiments

[0145] FIG. 1 depicts in simplified schematic form an alternative embodiment of a placement of an endovascular directed energy ablation catheter **13** into a patient **1** via an endovascular approach with a femoral vein puncture **17**. The distal end of the endovascular directed energy ablation catheter **13** (shown in phantom) is depicted in the left internal jugular vein **12** (shown in phantom) at the level of the left carotid artery bifurcation **2** positioned for directed energy ablation of a carotid artery. As depicted the endovascular directed energy ablation catheter **13** is inserted into the patient at insertion site **17** in the vicinity of the groin into a femoral vein **16** and advanced through the inferior vena cava **15**, superior vena cava **14**, left common jugular vein **11** and into the left internal jugular vein **12**. Alternatively, the insertion site may be selected to gain venous access through a brachial vein, a subclavian vein, a common jugular vein **11**, or any suitable peripheral vein. Furthermore, the distal end of the endovascular directed energy ablation catheter **13** may be positioned for carotid body ablation in other than the internal jugular vein **12** or one of its tributaries (e.g., a facial vein, not shown) depending on the particular vascular and neural anatomy of patient **1**. Also depicted is an optional angiographic catheter **97** positioned in the common carotid artery **3** for the purpose of creating an arterial angiographic image of the region of the carotid bifurcation **2** to allow for visualization of the region and for guiding directed energy ablation of the carotid body from the internal jugular vein **12**. As depicted, angiographic catheter **97** is inserted into a femoral artery **8** through insertion site **9** in the groin, then advanced through the abdominal aorta **7**, the aortic arch **6** and into the left common carotid artery **3** using standard angiographic techniques. It would be understood to those skilled in the art of endovascular interventions that means other than carotid artery angiography may be used to guide transvenous directed energy ablation of a carotid body. For example, extracorporeal ultrasonic imaging of the neck may be used, as well as intra-vascular ultrasound, computed tomography angiography, and other known modalities alone or in combination. It should also be understood that while FIG. 1 illustrates a left-side carotid body ablation, a right side carotid artery ablation or bilateral carotid artery ablations can be carried out in embodiments herein.

[0146] Sonography can be instrumental in guiding both percutaneous and endovascular procedures. Sonography can be performed from the surface of the skin, such as the neck, from inside the vasculature, from inside vasculature via imaging transducers positioned in or on an ablation catheter, or from a natural orifice such as the esophagus.

[0147] A directed energy device as used herein refers to an elongate device with an energy emitter configured to emit energy, and wherein the device is configured to deliver

directed energy into target tissue. In some embodiments the device includes a therapeutic ultrasound transducer (also referred to herein as an energy emitter), which can be in a distal region of the device. In methods of use, the device can be positioned in a patient's body proximate to a carotid body or an associated nerve(s) of the patient. The therapeutic ultrasound transducer is then activated and acoustic energy capable of thermally ablating tissue is delivered to the target tissue, ablating the target tissue, such as a carotid body. Directed energy can be expected generally to penetrate tissue in a way that causes volumic heating of a volume of tissue in the direction in which the energy is emitted. It is expected that as the distance from the emitter increases, the directed energy is deposited, converted into heat and deformation of tissue, and thus attenuated. There is a boundary or distance beyond which the directed energy will not penetrate in a biologically significant way because of attenuation in tissue. Volumic heating of target tissue, which occurs when using therapeutic ultrasound ablation energy as described herein, is different than conductive heating of tissue, which requires heating from the contact point, through intervening tissue, and to the target tissue. There may be, however, some degree of conductive heating that accompanies volumic heating. With directed energy, however, it is intended that volumic heating is the primary means by which the target tissue is heated. Additionally, directed energy such as therapeutic ultrasound energy does not require intimate contact with the target to be effectively delivered. Ultrasound can be transmitted through blood with approximately ten times lower absorption than in the carotid body area, for example, allowing the energy to be delivered without intimate vessel wall (e.g., carotid artery or jugular vein) contact, or even without serious regard to the distance from emitter to that wall. This can be important where a vessel wall is irregular or vulnerable.

[0148] Ultrasonic acoustic energy is produced by an ultrasonic transducer by electrically exciting the ultrasonic emitter, which is disposed on or about the elongate device (e.g., a catheter). In some embodiments ultrasonic transducers may be energized to produce directed acoustic energy from the transducer surface in a range from about 10 MHz to about 30 MHz. The transducer can be energized at a duty cycle, such as in the range from about 10% to about 100%. Focused ultrasound may have much higher energy densities localized to a small focal volume, but will typically use shorter exposure times or duty cycles. In the case of heating the tissue, the transducer will usually be energized under conditions that cause a temperature rise in the tissue to a tissue temperature of greater than about 45 degrees C. In such instances, it can be desirable to cool the luminal surface in which the elongate device is positioned, in order to reduce the risk of injury.

[0149] Embodiments of ultrasonic transducers for placement in a patient's body for ultrasonic ablation of a carotid body are described herein. Such ultrasound transducers may be employed in any carotid body ultrasound ablation device described herein. For example, any of the ultrasonic transducers herein may be incorporated in a carotid body ablation catheter having a deployable or expandable structure (e.g., a balloon, cage, basket, mesh, or coil) to position, align, and maintain stable position of the transducer in a vessel such as an external carotid artery or internal jugular vein.

[0150] FIG. 3A illustrates an exemplary embodiment of an ultrasound transducer. As shown in FIG. 3A, an ultrasound

transducer may be a non-focused, flat single element transducer, with two major surfaces approximately parallel to each other. The transducer aperture shape may be rectangular, or alternatively it may be round, oval or any other shape designed to fit an ablation device (e.g., catheter or probe). The width of the transducer aperture may be limited by the size (e.g., diameter) of the ablation device, for instance, to 2 F, 3 F, 4 F, 5 F, 6 F, 7 F, 8 F, 9 F, 10 F, 11 F. The length of the transducer aperture may be made larger than its width by increasing the length of the device distal assembly. The lengths of 4 to 6 mm have been proposed as a reasonable compromise between desired surface area and the ability of catheter to bend and navigate through anatomy. The surface of the rectangular essentially flat plate transducer can be made slightly convex in order to ensure convergence of the emitted ultrasonic energy beam.

[0151] It is generally desired to position the transducer with the emitter face surface pointing towards the target. The distal assembly containing the ultrasound transducer element of the ablation device may be guided in to place, for example in an external carotid artery, for instance, by using low intensity ultrasound Doppler guidance by the means of sensing blood flow in the internal carotid artery. The sample volume of the pulse wave Doppler along the ultrasound beam axis is adjustable in length and location. The location of the sample volume along the beam axis is preferably set to cover a range of about 2 to 15 mm (e.g., about 2 mm to 9 mm) from the transducer face. The ultrasound beam may be aligned with the aid of Doppler to cover a carotid body for ablation. Once the transducer is determined to be properly aligned, the carotid body and other desired target structures may be ablated using high intensity continuous wave, or high duty cycle (preferably greater than 30%) pulsed wave ultrasound. Pulsed ultrasound has advantage of cooling of the transducer and blood vessel by blood flow while the carotid septum more remote from the carotid blood flow continues to be heated. Ultrasound Doppler guidance and ultrasound ablation may be performed with the same transducer element, or alternatively with a separate transducer elements. Alternatively, the ultrasound transducer may consist of an annular array, for instance, a two-element array with a center disc for high intensity ablation and an outer ring for low intensity Doppler use.

[0152] The transducers herein may be configured to achieve thermal ablation with a maximum heating zone centered in tissue about 2 mm to 9 mm from the transducer face along the ultrasound beam axis. In some embodiments the transducer is configured to achieve thermal ablation with a maximum heating zone centered in tissue about 5 mm to about 8 mm from the transducer face. As set forth elsewhere herein, ablating in tissue this far from the transducer can allow for selective carotid body ablation while minimizing the risks associated with ablating other non-target tissue. Heating of tissue by endovascular ultrasound is affected by cooling by blood and by dissipation of mechanical energy of an ultrasonic beam in the tissue. The location of the maximum heating zone depends on the transducer design, specifically, the aperture size and frequency of operation, which defines the attenuation with distance and the shape of the ultrasound beam. In general, a higher frequency ultrasonic wave attenuates in a shorter distance as it travels through tissue and is absorbed. The maximum heating zone location may be fixed with a single element transducer. Alternatively, an ultrasound beam may be steered to a desired maximum

heating zone location using phased array technology, acoustic lenses or geometrically focused transducers. The device may be designed to achieve a volume of ablated tissue of about 8 to 300 mm³ (e.g., about 154+/-146 mm³). The combination of delivered energy, shape, direction of the ultrasound beam, and application time sequence may determine the volume of ablated tissue. Energy delivery, e.g., power settings and mode of operation (e.g., pulsed wave vs. continuous application time sequence), may be used to enhance heating in a target location or zone and achieve repeatable target tissue temperature over time. In an example embodiment, for a transducer having a width of about 2 mm and length of about 4 mm, an ultrasound frequency of operation may be chosen to be about 10 to about 30 MHz, (e.g., 15 to 25 MHz). In some embodiments the ultrasound is delivered at a frequency of between about 10-25 MHz. In some embodiments the ultrasound is delivered at a frequency of between about 10-20 MHz. In some embodiments the ultrasound is delivered at a frequency of between about 10-15 MHz. In some embodiments the ultrasound is delivered at a frequency of between about 15-30 MHz. In some embodiments the ultrasound is delivered at a frequency of between about 15-25 MHz. In some embodiments the ultrasound is delivered at a frequency of between about 15-20 MHz. In some embodiments the ultrasound is delivered at a frequency of between about 20-30 MHz. In some embodiments the ultrasound is delivered at a frequency of between about 20-25 MHz. In some embodiments the ultrasound is delivered at a frequency of between about 25-30 MHz.

[0153] The ultrasound transducer may be operated in the thickness resonance mode, i.e., the frequency of operation is substantially determined by the half wavelength thickness of the piezoelectric transducer element. The transducer element may be made of PZT-4 (Navy I) or PZT-8 (Navy III) type piezoceramic material or equivalent that exhibits low losses under high power driving conditions and may be incorporated in a piezocomposite structure. High intensity, high duty cycle, mode of operation may result in self-heating of the transducer element and surrounding structural elements. Therefore, the temperature of transducer or adjacent elements may be monitored with a temperature sensor (e.g., a thermocouple). If temperature is deemed to be too high, the transducer may be cooled down during use by a means of reducing duty cycle, or electrical power output into the transducer, or irrigation or circulating fluid cooling. Alternatively, transducer efficiency may be enhanced to reduce transducer self-heating by a means of electrical and acoustic impedance matching. For instance, the capacitive reactance of electrical transducer impedance may be cancelled or reduced by a means of inductive tuning. If the transducers perform imaging or Doppler sensing function the acoustic impedance, defined as a product of speed of sound and density, of commonly used piezoelectric materials is much higher than acoustic impedance of soft tissue (e.g., about 20x). Therefore, coupling of acoustic energy from the transducer element to soft tissue is poor. A means of improving coupling of acoustic energy may be to use a matching layer, or multiple matching layers, of about quarter wavelength thickness at the frequency of operation, on the transducer face between the transducer element and tissue. Theoretically, the acoustic impedance of a matching layer should be close to the geometric mean of that of the source, piezoelectric transducer element (about 30 MRayl), and load, soft tissue (about 1.5 MRayl). It is understood that some methods

of improving acoustic efficiency may be relevant more to high-energy delivery and some more to imaging and Doppler sensing.

[0154] In some embodiments the effectiveness of a therapeutic high energy mode transducer operating in continuous mode at or near resonance frequency can be optimized by including a matching layer made of material with acoustical impedance lower than the acoustical impedance of soft tissue or water (about 1.5 MRyal) divided by a transducer mechanical quality factor (between 0 and 100 measured in water). A common means of improving power transfer between water and acoustically hard ceramic by insertion of a quarter wavelength matching layer is not applicable in the case of a planar transducer undergoing large displacement at resonance. A thin therapeutic matching layer can be constructed, for example, by bonding a thin layer of polyester, polyurethane, or polyimide polymer directly to an emitting surface of the ceramic transducer. Alternatively, a therapeutic matching layer can be constructed of polyvinylidene fluoride (PVDF), which may be used as an imaging element or multi-element imaging array directly attached to the surface of a therapeutic transducer. PVDF is a piezoelectric polymer with low acoustic impedance well suitable for ultrasound imaging. Deposition of PVDF on the emitting surface of a high impedance, hard, therapeutic ceramic may help to miniaturize the design and optimize power transmission in therapeutic mode and obtain an ultrasound imaging function in the same stack of transducer.

[0155] FIG. 3A shows an exemplary piezoelectric transducer element 150 with a top (or front) electrode 151 and bottom (or back) electrode 152. The transducer element 150 may be made of PZT-4 (Navy I) or PZT-8 (Navy III) type piezoceramic material. PZT-4 and PZT-8 type materials are known as "hard PZT", which have a relative high mechanical quality factor (e.g., about 500 to about 1000) and high Curie temperature (e.g., greater than 300° C.), and are therefore well suited for high intensity and high duty cycle use. The top 151 and bottom 152 electrode of the transducer element may be solderable to provide reliable electrical connections to transducer surfaces. The electrode with negative polarity is preferably on the outer radiation surface of the transducer, facing the tissue target. In this embodiment that is the top electrode 151.

[0156] FIG. 3B shows an exemplary piezoelectric transducer element 153 with an undersized electrode 154 on the backside of the element. The purpose of the undersized electrode is to avoid the possibility of unwanted electrical connections (i.e., short circuit) to the transducer housing assembly. The top (or front) electrode 155 may cover approximately the full face of the transducer element 153.

[0157] FIG. 3C shows an example of mounting of a transducer element 150 into a housing assembly 157 of which only a partial view is shown for illustration purposes. The transducer element 150 may be located approximately at or close to the axis of a shaft of an ablation device (e.g., catheter or probe) to allow a maximum transducer width. The transducer element 150 rests over a backing cavity 158 on an acoustic insulator 159, for instance an O-ring or frame made of soft compliant material. The purpose of the insulator is to isolate the acoustic vibration of the transducer element from the housing assembly. The sides of the transducer element 150 may be sealed with filler 164 that provides hermetic sealing. At the backside of the transducer element a backing cavity 158 may be filled with gaseous or

foamy material of low acoustic impedance. Low acoustic impedance may be defined as a product speed of sound and density of material. The backing cavity is hermetically sealed from the environment (not shown) to prevent any liquid from coming in contact with the backside of the transducer element 150. Electrical connections may comprise negative polarity 160 connected to the front transducer electrode 162, and positive polarity 161 connected to the back transducer electrode 163. Electrical connections may be soldered or welded for example.

[0158] Alternatively a material with high acoustic impedance can be used to prevent spreading of energy in the direction other than target. Backing can be made of dense and high sound speed materials such as metals, for example stainless steel, that reflect acoustic energy. Generally transition or interface between materials with significantly different acoustic properties (e.g., speed of sound) will reflect acoustic energy.

[0159] FIG. 3D shows a top view, or front face, of a transducer distal assembly. A wire lumen 165 may provide a path for electrical wiring to the transducer that at the proximal end of the device is connected to a controller that may contain a pulse wave Doppler circuitry and a RF signal source for ablation. The same wire lumen 165 may be used for thermocouple wires connected to a thermocouple 166 positioned on the transducer element or distal assembly of the device.

[0160] FIG. 3E shows an embodiment of a distal portion of an ultrasound ablation catheter comprising a rectangular ultrasound transducer 150 (as shown in FIGS. 3A, 3C, and 3D) positioned at or near an axis of the catheter shaft 167. The catheter may be configured to be controllably deflectable by applying tension to pull wires with an actuator in a handle. The pull wires may run through the shaft and be anchored near the distal portion of the catheter.

Ultrasound Carotid Body Ablation from an Endovascular Catheter Positioned in a Vein

[0161] The disclosure herein includes embodiments in which an endovascular ultrasound ablation catheter is delivered to an internal jugular vein or one of its tributaries to direct ablative energy to a carotid septum. Trans-venous instruments can have an advantage over trans-arterial ones in that they have a lower risk of brain embolization. Additionally, a larger instrument can be used in trans-venous approaches.

[0162] One aspect of the disclosure is a method of carotid body ablation that includes introducing an elongate device such as a catheter into the venous system of the patient, advancing a distal end of the catheter into an internal jugular vein or one of its tributaries proximate to a carotid septum, wherein the distal region includes a directional emitter of high-energy ultrasound capable of delivering ablative acoustic energy, aligning the emitter with the carotid septum, and directing energy into the septum to ablate the target tissue (e.g., carotid body, tissue in the carotid septum, carotid body nerves).

[0163] FIGS. 4A and 4B illustrate an exemplary embodiment of a trans-jugular ultrasound ablation catheter. As can be seen FIG. 4A, the proximity of a jugular vein to a carotid septum and carotid body provides an opportunity to ablate the carotid body with a device positioned in a jugular vein. Catheter 313, as shown in FIGS. 4A and 4B, includes an ultrasonic emitter 230 and optional receiver. The emitter is capable of delivering high-energy ultrasound in a selected

direction (e.g., directed high energy unfocused ultrasound beam). Reflective backing 231 (e.g., an acoustic insulator made from, for example, air, foam, or dense metal) reflects ultrasound waves 232 or ensures they are mostly directed in the desired direction. Frequency, power, duration and aperture are calculated or experimentally determined, considerations of which are described in detail above, to ablate tissue within a carotid septum 205 but to prevent ablative energy from penetrating through and beyond the septum, for example beyond a medial boundary 233 of the carotid septum. For example, the emitter can be configured so that ablation energy delivered may be deposited no more than about 12 mm, 11 mm, 10 mm, 9 mm, 8 mm, 7 mm, 6 mm, 5 mm, 4 mm, or 3 mm into tissue from emitter 230. In some embodiments the emitter is configured such that the high energy ablation ultrasound will lose ablation power after penetrating about 3 mm to about 12 mm into soft tissue, such as about 3 mm into soft tissue, about 4 mm into soft tissue, about 5 mm into soft tissue, about 6 mm into soft tissue, about 7 mm into soft tissue, about 8 mm into soft tissue, about 9 mm into soft tissue, about 10 mm into soft tissue, about 11 mm into soft tissue, or about 12 mm into soft tissue. There may be some patient to patient variability in the size of a septum, and thus it may be beneficial to obtain visualization of the septum prior to ablation, obtain an estimated size of the septum, and use delivery parameters based on the estimated size.

[0164] Excitation frequencies in the range of about 10 to about 30 MHz, such as between about 10 MHz to about 20 MHz, can be expected to produce the desired effect, including sufficient depth of penetration of ablative energy and at the same time containment of the desired ablation zone. Cooling from blood flow within internal 90 and external 91 carotid arteries may assist containment of the ablative thermal energy, or ablation zone, in a carotid septum. Thus a heat distribution from an ablative ultrasound beam may be shaped additionally by inhomogeneous heat conduction of the area influenced by cooling blood flow and enhancing ultrasound induced heating related bio-effects in the target space between the internal carotid artery 90 and external carotid artery 91 (i.e. carotid septum 205). Due to high blood flow and consequent effective thermal cooling of blood vessels, ultrasound energy in the selected frequency range travels through the vessel walls and blood without significant biologic effects and therefore only the septum will be selectively heated. One aspect of this disclosure is a method of delivering high intensity ablative ultrasound towards the carotid septum while utilizing the cooling effects of the blood in the internal and external carotid arteries to selectively ablate only septal tissue. Some attenuation through scattering can be expected to reduce the posterior ultrasound effects and protect non-target structures behind the arteries. This principle can be classified as forming of a lesion using thermal heating by an ultrasound beam that is shaped in the tri-vessel space. In some embodiments the emitted ultrasound energy ablates septal tissue by increasing the temperature of the septal tissue to greater than about 45 degrees C., yet tissue outside of the septum remains less than about 45 degrees C. and is thus not ablated. Ablation is a function of temperature and time, and longer exposure to lower energy and temperature can also ablate tissue. This disclosure focuses mainly on temperature and includes treatments

that last about 5 to about 60 seconds. The temperatures mentioned herein however shall not be interpreted as strict limitations.

[0165] Choice of ultrasound therapeutic parameters such as power, frequency, time and regime (e.g., pulsed or continuous) may ensure that an ultrasound beam does not ablate tissues deeper than about 15 mm (e.g., no deeper than about 9 mm) from the jugular vein. For the typical attenuation of ultrasound in muscle tissue of 1 dB/cm/MHz, the characteristic depth of unfocused ultrasound penetration in tissue is the inverse of attenuation coefficient divided by frequency. For example, at 10 MHz the characteristic penetration depth is 7.7 mm and at 20 MHz the characteristic penetration depth is 3.8 mm, which roughly corresponds to a one example of a range of target distances in a trans-jugular catheter configuration.

[0166] FIG. 4B illustrates catheter 313 introduced from below (e.g., via femoral vein access). An endovascular approach from below may comprise puncture of a femoral vein in the groin of the patient and threading the catheter through vena cava into a desired jugular vein, such as is shown in FIG. 1. Other alternative approaches such as from a jugular veins and branches of jugular vein and other veins of the body such as a subclavian vein are also possible and may have advantages in some clinical situations.

[0167] Directing the beam from a jugular vein 12 into the septum between two carotid branches benefits the shaping of the lesion by cooling effects from carotid arteries. As illustrated by FIG. 4A the energy beam 232 is constrained between two carotid artery branches that are protected from thermal damage by high flow of blood. The anatomy in this region therefore provides an intrinsic advantage in that if the beam is slightly misaligned and points at a slightly wrong angle, it will encounter the internal or external carotid artery, which will resist heating of immediately surrounding tissue by its cooling effect. The beam, or portion of the beam directed between the branches, will be subject to less cooling and will result in ablation of tissue where the target organs, such as carotid body 89 and associated nerves, are expected to reside (i.e., in a carotid septum). As a result, the carotid septum is selectively heated and thermally ablated, which is one of the aspects of this disclosure. As set forth above, this disclosure also includes methods of selectively ablating target tissue by delivering high intensity ultrasound energy into a region of the anatomy so that blood flow will provide a cooling effect and therefore facilitate the containment of the ablated tissue to a desired region. In the case in this embodiment, the ablated tissue is contained in the carotid septum.

[0168] Directing and targeting an ultrasound ablation beam 232 at a target site such as a carotid septum 205 from within a jugular vein may be facilitated by detecting vasculature such as the common carotid artery 3, internal carotid artery 90 and external carotid artery 91, and carotid bifurcation 2 using diagnostic ultrasound such as Doppler ultrasound. Such diagnostic ultrasound may provide an indication (e.g., visual images, acoustic, or electrical signals) of the vasculature by detecting blood velocity, direction of flow, pulsations of flow and turbulence while manipulating a catheter (e.g., rotational and translational manipulation) that comprises at least one ultrasound transducer.

[0169] In some embodiments translational aiming (in some instances being aligned with) may be achieved by

detecting a carotid bifurcation saddle **2** and aiming an ultrasound treatment transducer (also referred to herein as an ultrasound ablation transducer or ultrasound ablation emitter) with a target site relative to the carotid bifurcation saddle. In some embodiments the ultrasound treatment transducer is aimed about 5 to about 15 mm cranial to the bifurcation, saddle in some embodiments about 10 to about 15 mm cranial to the bifurcation saddle, in some embodiments about 10 mm to about 12 mm cranial to the bifurcation saddle, and in some embodiments about 5 to about 10 mm cranial to the bifurcation saddle. A carotid bifurcation saddle can be detected from a position along the length of a jugular vein **12** as a location where one strong blood velocity signal representing a common carotid artery **3** separates abruptly into two arteries, the internal **90** and external **91** carotid arteries. An ultrasound ablation beam may be aimed at a location about 5 to about 15 mm above the level of the bifurcation saddle by advancing or retracting the catheter. Aiming the beam at a location about 5 to about 15 mm caudal to the bifurcation saddle aims the beam into the carotid septum to facilitate ablating the carotid body.

[0170] In some embodiments a method of ablation includes detecting one or both of the internal and external carotid arteries. They can be detected by rotating a diagnostic transducer, which can occur with a catheter or balloon, or within the catheter or balloon. The treatment transducer can then be aimed at a target site relative to the internal and external carotid arteries. In some embodiments the external and internal carotid arteries are detected, and the treatment transducer is rotationally aimed approximately between the internal and external carotid arteries. In this orientation relative the two arteries, the ultrasound treatment transducer is aimed to ablate the septal tissue and thus the carotid body. In other embodiments aiming the beam is aided by other visualization techniques, such as MRI, CTA, or Fluoroscopy. An ultrasound transducer may optionally also be capable of delivering and receiving low power ultrasound that can be used for imaging of carotid arteries, Doppler imaging, or pulse Doppler imaging. Examples of transducers configured in this regard are described herein. Doppler signal feedback to an operator or computer controlling energy delivery need not be necessarily an image. It can be an indicator such as a curve, a number, an acoustic signal, an LED bar, or an indicator light color or intensity.

[0171] Alternatively or additionally, ultrasound imaging may be applied from an external transducer placed on skin of a patient's neck and used to guide therapy. Externally applied ultrasound imaging may incorporate biplane imaging and Doppler flow enhanced imaging. Alternatively, additional ultrasound emitters and receivers can be incorporated in the catheter design.

[0172] Alternatively or additionally, single or multiple ultrasound transducers may be positioned on the distal section of a trans-jugular catheter such that ultrasound reverberation between the exterior of the neck surface and ultrasound transducers is sensed in electrical impedance or by means of ultrasonic imaging thus allowing alignment of the catheter with respect to the lateral landmarks of the neck effectively pointing the therapeutic transducer in a medial direction toward the intercarotid septum. The lateral reflections provide acoustic guidance to the catheter ultrasound transducers with the effect maximized when catheter ultrasound imaging transducer becomes substantially coplanar with the exterior neck surface, which may coincide with a

desired rotational position relative to the bifurcation of the carotid arteries. Alternatively, similar lateral guidance may be achieved by placing a substantially flat echogenic reflector or active low power ultrasound transducer on the surface of the neck.

[0173] In some embodiments herein the ablation catheter may be advanced into an internal jugular vein from the groin, from a subclavian, from a brachial vein, or by direct puncture using methods somewhat similar to ones used for biopsy or central access catheter placement. In some cases a facial vein, or other vein branching from an internal jugular vein, may provide a closer proximity to a carotid septum for placement of an energy delivery element of the catheter. The jugular vein as a venous position for the catheter is therefore merely illustrative.

[0174] As described in methods herein, a catheter may be advanced up and down the jugular vein until a bifurcation of a common carotid artery and carotid septum just above it are clearly detected. If external ultrasound is used, the catheter may be made visible with ultrasound by addition of an echogenic coating. This can be confirmed by a Doppler pulsatile velocity signal or ultrasonic imaging. A space, indicating a carotid septum, between two large vessels with high pulsatile blood flow should be easily detectable. Pulsed Doppler at the preselected depth of 3 to 10 mm (e.g., 3 to 5 mm) can be chosen to avoid interference from venous blood flow.

[0175] In some embodiments a catheter positioned in a jugular vein may be rotated around its axis until the ablation, or treatment, transducer aperture is facing the carotid septum pointing into the gap between internal and external arteries. Alternatively a transducer with a directional emitter can be rotated inside the catheter. If the Doppler emitter and receiver are located in the distal portion of the catheter placed in a jugular vein, certain advantages may be realized. A low energy Doppler beam can be facing the same direction as the high energy ablation beam. A Doppler signal can then be used for targeting and directing the ablation beam into the septum. The septum can be located as a valley of low velocity area between two peaks or high velocity areas. Alternatively, several Doppler transducers can be incorporated in the distal tip aiming beams silently at an angle to the direction of the face of the aperture of the high energy beam in order to detect both carotid arteries by their high velocity flow. A vein may be distended and a catheter tip maneuvered into position so that a high-energy emitter is aiming into the middle of the gap between two strong Doppler signals representing an internal and external carotid artery. A computer algorithm may assist or automate such aiming.

[0176] During ablation the ultrasonic energy emitter may get hot and may require cooling. The catheter may be configured to position the transducer in an internal jugular vein so it does not touch the wall of the jugular vein while delivering high energy for the purpose of ablation. For example, the catheter may comprise a protective membrane such as balloon **145**, as shown in FIGS. **4A** and **4B**. The balloon **145** separates the transducer **146** from the vessel wall **147** while providing a conduit for an energy beam and cooling of the transducer, the blood in the vein **12**, and the tissue of the wall of the jugular vein. The balloon **145** may be made of a thin polymer film that can be compliant or not compliant but is capable of sustaining some pressure, providing firm contact with the wall of the vessel and conducting ultrasound in the selected frequency range without

significant attenuation, reflection or heating. The balloon may be filled with a circulating fluid **148**, such as sterile water or saline, which is biocompatible and conducts ultrasound well without absorbing significant energy. The fluid may be externally chilled, recirculated by an external pump (not shown) through the catheter shaft, or can be just infused and released into the bloodstream in relatively small quantities sufficient to keep the fluid and the emitter submerged in fluid at a desired low temperature.

[0177] A protective membrane may fully encompass the distal end of the catheter forming a balloon around ultrasound transducers or, as shown in FIGS. **9A** and **9B**, a protective membrane **250** may partially encompass a selected ultrasound transducer **251**. The protective membrane can be formed around a therapeutic transducer in a shape of a convex, concave, or Fresnel acoustic lens and filled with liquid coolant fluid **252** such as Fluorinert with acoustic properties substantially different from that of blood. An ultrasonic beam may be shaped by a protective membrane lens to a predefined focused or defocused pattern in order to obtain selected regional sensitivity in Doppler imaging or a delivered therapeutic dose in the ablation area. Alternatively a transducer with a predefined thin-wall expandable protective membrane may form a directional emitter that can be manipulated to form a directional beam that can be targeted to different depths. The target depth of Doppler emitters and receivers may be configured to enable ultrasound beam shaping and focusing advantages realized when facing substantially different anatomy in the jugular vein and carotid complex.

[0178] The ablation depth control may be achieved by placing a catheter in a jugular vein and manipulating the lens internal fluid pressure to expand the protective membrane in a predefined repeatable shape that produces an acoustic convergent or divergent lens effect to the ultrasound beam and preferentially targets the ultrasound beam into a specific target depth in the bifurcation of a carotid artery and a carotid septum. For example, as shown in FIG. **9A** a membrane **250** is inflated with coolant **252** creating a lens shape that focuses an ultrasound beam **253** on a target region **254**. Comparatively as shown in FIG. **9B** the membrane **250** may be inflated with coolant **252** at a different pressure to alter the lens shape to focus the ultrasound beam **253** on a target region at a different distance. The expandable membrane can be formed from a variety of compliant polymer materials such as Kraton (styrene blend), polyethylene, polypropylene, Pebax, or Latex. Alternatively, an expandable membrane may be used to control the positioning of the catheter inside the jugular vein with respect to the distance to the carotid complex.

[0179] A distal end of an embodiment of a carotid body ablation catheter, shown in FIG. **10**, comprises an ultrasound transducer **255** and a PVDF imaging array **256** positioned near a distal end of a catheter shaft **258**. An acoustic insulator **257** such as stainless steel may be positioned on a backside of the transducer **255** to ensure an imaging or ablation beam is directed in a direction **259** orthogonal to the front surface of the transducer **255**. An expandable membrane **250** encompasses a cavity in front of the transducer. Liquid, such as a coolant, may be injected into the membrane cavity through an inflation lumen or tube **260** to inflate the membrane **250** to a desired shape, which may focus or direct the ultrasound beam.

[0180] In alternative embodiments, any of the catheters comprising an ultrasound ablation transducer and an expandable membrane, such as those in FIG. **9A**, **9B**, or **10**, can also include any of the diagnostic transducers described herein, such as those shown in FIGS. **5A-B**, **6A-B**, **7A-C** mounted to the catheter, which may be used to assist in positioning the ablation transducer and aligning it with respect to one or more vascular landmarks, such as a carotid bifurcation, internal carotid artery, external carotid artery, or combination thereof, to direct an ablation ultrasound beam toward a target tissue volume, such as a carotid septum or position within a carotid septum.

[0181] An ablation catheter may comprise an ultrasound ablation transducer and an expandable membrane, such as membrane **250** shown in FIG. **9A**, **9B**, or **10**, wherein the ultrasound ablation transducer may also be used for diagnostic ultrasound such as Doppler. These catheters may be positioned in an external carotid artery and rotated while assessing a diagnostic signal, which may be used to find vessels such as an internal carotid artery or internal jugular vein. The transducer may be placed at a desired distance cranial from a carotid bifurcation in an external carotid artery, for example about 5 to about 15 mm, or about 5 to about 10 mm, with the help of fluoroscopic imaging. For example, the catheter may have a radiopaque marker positioned the desired distance (e.g., about 5 mm to about 15 mm, or about 5 mm to about 10 mm) proximal to the transducer; contrast may be delivered to a common carotid artery (e.g., from a delivery sheath), a radiographic image may be taken of the carotid arteries and the distal portion of the catheter, and the radiopaque marker may be aligned with the carotid bifurcation. When the diagnostic transducer is aimed at an internal carotid artery or approximately the center of an internal carotid artery and the transducer is positioned a desired distance cranial from the carotid bifurcation it may be expected that the transducer is aimed through a carotid septum. An ablation ultrasound beam may be directed into the target tissue in the carotid septum. Optionally, the catheter may further comprise a deflectable section proximal to the transducer (e.g., between about 5 mm and about 30 mm proximal to the transducer) that may be used to direct the angle of the ultrasound beam with respect to the external carotid artery, which may be useful to adjust for a variety of carotid vasculature geometries such as narrow or wide bifurcation angles. Optionally, the catheter may further comprise a deployable structure such as a balloon, cage, mesh or helix positioned on the catheter distal to the transducer, which may be used to engage and stabilize the distal portion of the catheter in an external carotid artery. The deployable structure may deploy to a size suitable to engage in an external carotid artery, for example having a diameter of about 4 to about 6 mm. The deployable structure may retract so it can fit in a delivery sheath, for example having a diameter of less than about 3 mm (e.g., between about 2 mm and about 2.4 mm).

[0182] The disclosure herein also includes methods, devices, and systems for ablating a target site by positioning an ablation needle within a lumen of a vein adjacent to the target site, inserting the needle through the vein and into perivascular space containing the target site, delivering an ablation agent into the perivascular space by using the needle, and withdrawing the needle from the perivascular space back into the vein. There may be potential benefits for positioning a device via a trans-venous approach for a

carotid body ablation procedure compared to a trans-arterial approach. For example, jugular veins have thinner walls compared to carotid arteries which may be easier to pass an ablation needle through; jugular veins are distensible and flexible and a change in conformation may be achieved by applying force from inside or outside the vessel which may be advantageous for facilitating position of a catheter or accessing a target ablation site; jugular veins have no atherosclerotic or arteriosclerotic disease and blood flows away from the brain eliminating a risk of causing a brain embolism, which may be a concern with a procedure in carotid arteries; a trans-jugular approach may access an intercarotid septum from a lateral side; perforation with a needle or catheter through a wall of a vein (e.g., jugular, facial veins) has less risk of complications such as hematoma due to compressibility of the venous vessel compared to carotid arteries; possible reduction of blood flow in a jugular vein has less risk of flow limitation to the brain compared to reduction of flow in an internal carotid artery.

[0183] A representative exemplary anatomy with exemplary characteristic dimensions is shown in FIG. 2 including AA—distance between the carotid arteries (e.g., in a range of about 3 to 5 mm), BB—distance between the jugular vein and center of a carotid septum (e.g., in a range of about 5 to 15 mm), CC—distance between a center of a carotid septum and important non-target structures on a medial side of the carotid septum (e.g., in a range of about 5 to 10 mm). Embodiments described herein may be configured to safely and effectively deliver ablative energy to a target tissue such as the carotid body or carotid septum from a proximate vein such as a jugular vein or facial vein.

Ultrasound Ablation Catheters with Imaging Transducers

[0184] In some embodiments an ultrasound carotid body ablation catheter comprises at least one diagnostic ultrasound transducer and an ultrasound treatment transducer, wherein the transducers are positioned on the catheter relative to one another such that when the diagnostic ultrasound transducers are aligned with vasculature landmarks, the treatment transducer is aligned with a target ablation site (e.g., carotid septum). Carotid vascular landmark as used herein includes an internal carotid artery, an external carotid artery, a carotid bifurcation, and a common carotid artery. This configuration allows an alignment of a diagnostic transducer and a landmark to indicate an alignment of a treatment transducer and target tissue. In some embodiments when the diagnostic transducer is aligned with the landmark, the treatment transducer will be in a proper position to be activated without additional movement to successfully ablate the target tissue. In FIGS. 5A, 5B, 6A, and 6B diagnostic ultrasound transducer 125 may be positioned a predetermined distance, such as about 5 to about 15 mm, proximal to a treatment ultrasound transducer on a catheter such that when the diagnostic transducer 125 is aligned with a landmark 2, in this case a carotid bifurcation, the treatment transducer 126 is a predetermined distance 127 (e.g., about 5 to about 15 mm) distal to the bifurcation and aligned with an ablation target 128 in a carotid septum. The diagnostic transducer 125 may provide a signal as feedback to material (e.g., tissue, blood flow) reflecting ultrasound waves in the transducer's zone of capture 129. A sweeping motion may be created to search for the landmark, such as a common carotid artery, or carotid bifurcation by rotationally or translationally moving the catheter or by electrically or mechanically manipulating the transducer. Feedback from the diag-

nostic transducer 125 may be processed as images 130 as shown in FIG. 6B, acoustic sounds, waveforms, or electrical signals.

[0185] FIGS. 7A-C illustrate an exemplary ablation catheter that includes first and second diagnostic ultrasound transducers. As shown in FIG. 7A, the catheter may further comprise a first diagnostic ultrasound transducer 132 and a second diagnostic ultrasound transducer 133 configured to detect an internal 90 and external 91 carotid artery. The transducers can be configured to capture an image 134, as shown in FIGS. 7B and 7C, an acoustic signal, or an electrical signal. FIGS. 7B and 7C illustrate a trans-section of the two arteries. The second diagnostic ultrasound transducer 133 is positioned on the catheter so it is aiming the same direction as the treatment transducer 137. When the catheter is rotated to a position in which the second diagnostic transducer is centered 136 between the internal and external carotid arteries, as shown in FIG. 7B, and the first diagnostic transducer 132 is aimed at the carotid bifurcation 2, as shown in FIG. 7C, the ultrasound treatment transducer 137 is aligned with a target site 128 in a septum approximately centered between the internal and external carotid arteries and above the bifurcation a predetermined distance, such as between about 5 to about 15 mm, about 5 to about 10 mm, about 8 to about 10 mm, or about 10 mm to about 15 mm.

[0186] FIGS. 8A-D illustrate an exemplary ablation catheter with three diagnostic ultrasound transducers and one treatment ultrasound transducer. As shown in FIGS. 8A-D, the catheter includes a first diagnostic transducer 140 disposed on the catheter to align with a carotid bifurcation 2, a second diagnostic transducer 141 disposed on the catheter to align with an internal carotid artery 90, and a third diagnostic transducer 142 to align with an external carotid artery 91. The catheter also includes an ultrasound treatment transducer 143 positioned on the catheter relative to the three diagnostic transducers to aim an ablation beam at a target site between the internal and external carotid arteries and a predetermined distance, such as about 5 to about 15 mm, about 5 to about 10 mm, about 8 to about 10 mm, or about 10 to about 15 mm, cranial of a carotid bifurcation when the diagnostic transducers are aligned. Alternatively, one or more of the diagnostic transducers may be movable in relation to the catheter shaft. For example, diagnostic transducers 141 and 142 shown in FIG. 8A may mechanically move (e.g., with a gearing mechanism) to adjust the angle between the two transducers while maintaining the treatment transducer 143 centered between the two moving diagnostic transducers. This may allow the alignment to adjust to varying septum widths. In use, all of the catheters and methods shown in FIGS. 4A-8D create a lesion that is contained substantially in the carotid septum, and thus avoiding non-target tissue. In addition, a combination of blood flow cooling in the vein and a choice of ultrasound therapeutic regime can help cool the vein and the emitter that may get hot during operation while enhancing the ultrasound heating of the carotid septum.

Ultrasound Ablation Catheters Configured to Accept a Separate Imaging Catheter

[0187] An endovascular catheter for carotid body ablation may be configured to both ablate target tissue using therapeutic ultrasound and image tissue for targeting purposes. A catheter may comprise an ultrasound ablation transducer

(also referred to as a treatment transducer, or therapeutic transducer), be configured and adapted to accept an imaging catheter, be adapted to identify a direction of aim of the treatment transducer with respect to the image produced by the imaging catheter, and be adapted to direct energy from the treatment transducer to a target identified by the imaging transducer.

[0188] There are a number of ultrasound imaging catheters including intravascular ultrasound (IVUS) catheters and intracardiac echocardiography (ICE) catheters on the market that are used for imaging from within a patient's body. For example, Vision® PV 0.035 by Volcano is used for imaging diseased vessels from inside a vessel; UltraICE™ by Boston Scientific is used for imaging during endovascular cardiology procedures. An ICE catheter is used for imaging within a heart however may be functional in the applications described herein. Such imaging catheters may be configured to create an ultrasound-based video representing a cross sectional slice of tissue having a radius of about 50-60 mm around the imaging transducer on a distal region of the catheter. Ultrasound signals transmitted and received from the imaging catheter are controlled and processed by a console external to a patient and an image may be produced and displayed to help a user identify tissues or other objects in the field of view. Additional processing may help to identify features such as blood flow, presence of plaque, or tissue differentiation. Existing ultrasound imaging catheters may have a diameter of about 8 to 1° F. (e.g., 8.2 F, 9 F) for example. In some embodiments of ablation catheters an existing imaging catheter, or a custom made imaging catheter similar to those known in the art, may be inserted into a carotid body ultrasound ablation catheter to help identify a target ablation site (e.g., carotid body, carotid septum, carotid body nerves), and identify the position of the target ablation site relative to the treatment transducer or its direction of aim.

Ablation Transducer in Front of Imaging Transducer

[0189] An embodiment of an ultrasound ablation catheter 305 that is adapted and configured for ultrasound imaging, as shown in FIG. 11, is configured with an ablation transducer 300 positioned in front of an imaging catheter lumen 301. In this case, the positional reference, in front, may be defined as toward the direction of delivery of ultrasound ablation energy 302 from the ablation transducer or the side of the catheter that is aimed at a target. An existing ultrasound imaging catheter (e.g., IVUS or ICE catheter) 303 may be inserted through the imaging catheter lumen to position an imaging transducer 304 or transducers distal to the ablation transducer, wherein the imaging catheter lumen is behind the ablation transducer. The ablation catheter 305 may have a diameter in a range of about 11 FR to 13 FR (e.g., about 12 F) and be delivered through a deflectable sheath. For example, a compatible sheath may be 12 F compatible, have an outer diameter of about 16 F, be deflectable in at least one direction and be used with a dilator. The ablation catheter may comprise an ultrasound ablation transducer 300 such as the ablation transducers described herein, for example the ablation transducer may be substantially flat with a width of about 2 mm and a length of about 6 mm. The transducer may be configured to resonate at a frequency in a range of about 15 MHz to about 25 MHz (e.g., about 20 MHz). The ablation transducer may be mounted to a backing material 306 that reflects or shields

ultrasound waves so ablation energy is only directed in a desired direction of delivery. The backing material may be made as described herein for similar embodiments for example made of a dense material such as stainless steel or an absorbent material such as air or an epoxy filled with microspheres of air. As shown, the imaging catheter lumen may pass through the backing material, or alternatively if a backing material is thin and mounted to a ablation transducer support component the imaging catheter lumen may pass through the ablation transducer support component. The imaging catheter lumen 301 may pass through the shaft 307 of the ablation catheter, which may be an extruded polymer such as Pebax, to a proximal region of the catheter. An ultrasound imaging catheter may be delivered through the imaging catheter lumen to position the imaging transducer(s) 304 in an echolucent chamber 308 distal to the ablation transducer. For example, the imaging transducer(s) may be placed with an imaging-to-ablation-transducer-distance 309 of about 0 mm to 5 mm (e.g., about 2 mm, about 1 mm, about 0.5 mm). This configuration aligns an imaging plane approximately parallel to a direction of delivery of ablation energy and may be used to deliver ablation energy while imaging simultaneously or consecutively without needing to move either the imaging transducer(s) or ablation transducers. The echolucent chamber 308 may be a space within an echolucent shell 312 that allows imaging or ablation ultrasound waves to pass through without creating a significant echo. The echolucent shell may be made of a thin polymer such as nylon and may also be visibly transparent or translucent to allow a user to see into the echolucent chamber for example to position an imaging transducer or ensure coolant is flowing properly or that air bubbles are removed. The echolucent chamber may be hermetically sealed to contain flowing coolant. In this embodiment coolant may be delivered through a coolant delivery lumen 314, circulate in the chamber to cool the ablation transducer 300 and exit the chamber along the Imaging catheter lumen 301. The ablation catheter may further comprise an aiming artifact 310, as shown, which may be positioned behind the imaging catheter lumen 301 or in a position that indicates a relative direction of delivery of ablation energy. For example, an aiming artifact may be a hypotube containing air and sealed at both ends, or an alternative design that is sonographically distinguishable such as embodiments described herein. As shown in FIG. 11 the aiming artifact may support a distal tip member 311, which may be a hemispherical piece made for example from a polymer or metal and adhered to the aiming artifact or echolucent shell 312. A distal tip member may be atraumatic when pressed against a vessel wall and allow for insertion into and passage through a sheath. A user may position the ablation catheter containing the imaging catheter, for example in a jugular vein or facial vein near a target carotid body, by obtaining an ultrasound-based video and positioning the catheter with the understanding that ablation energy will be delivered a pre-defined distance proximal to the imaging plane. For example, the ablation energy may be delivered in a range approximately starting at the imaging-to-ablation-transducer-distance 309 proximal to the imaging plane and with a height approximately the height 313 of the ablation transducer. For example, if the imaging-to-ablation-transducer-distance is 0.5 mm and the ablation transducer height is 6 mm then it may be understood that ablation energy will be delivered between 0.5 and 6.5 mm proximal to the

imaging plane and in a direction relative to the aiming artifact (e.g., opposite direction). The catheter may comprise electrical conductors 315 to deliver current to the ablation transducer or communicate a signal from a sensor such as a temperature or pressure sensor.

[0190] Alternatively, a similar configuration may comprise an imaging transducer or set of transducers that is manufactured as part of the ablation catheter instead of inserted as a separate device into an imaging catheter lumen of the ablation catheter.

[0191] In alternative embodiments a catheter may be configured to position imaging transducers of an imaging catheter proximal to the ablation transducer.

An Embodiment of an Ablation Catheter for Use with an Imaging Catheter

[0192] An ablation catheter configured to accept an ultrasound imaging catheter may have a distal assembly 510 as shown in FIGS. 12A to 12F. The distal assembly may be connected to an elongate tube 511 such as an extruded Pebax tube that makes a catheter shaft. The distal assembly comprises an ablation transducer support component 512 connected to the shaft, an ablation transducer 513 mounted to the ablation transducer support component, an echolucent shell 514 defining a chamber 515 and connected to the ablation transducer support, a fiducial marker 516 positioned to provide an indication of a direction of aim 517 of the ablation transducer, and a radio-opaque tip 518.

[0193] FIG. 12E shows a cross section of the catheter shaft of this embodiment. An extruded tube (e.g., a Pebax extrusion) 520 contains a wire braid 521 to increase strength and improve torqueability and a lumen. The wire braid may be coextruded or laminated to the extruded tube for example. Two PTFE liners are inserted into a lumen of the extrusion 520 to create two separate lumens. Alternatively, a Pebax extrusion may be extruded with two or more lumens. A first PTFE liner 523 defines a lumen 542 dedicated to contain wires 525 and delivery of coolant. Delivery of coolant, which is used to cool the ablation transducer, through a lumen containing the wires may have an added benefit of cooling the wires. The wires may be, for example, conductors to deliver high frequency current from a console to the ablation transducer and to connect a temperature sensor (e.g., thermocouple) in thermal communication with the ablation transducer to the console. In this figure three wires include a constantan wire and a copper wire to create a T-Type thermocouple soldered to the ablation transducer and a copper wire to deliver current to the transducer. One of the copper wires may be a common conductor to complete the thermocouple circuit and ablation energy circuit. Coolant fluid such as sterile water or saline may be provided in a vessel (e.g., bag, bottle) and pumped through tubing by a peristaltic pump to a coolant inlet port on a proximal region of the ablation catheter that is in fluid communication with the first liner or fluid delivery lumen 542. A pressure relief valve (not shown) may be positioned in line with the coolant inlet tubing to release coolant in the event that an occlusion somewhere along the coolant pathway inadvertently blocks coolant flow. The pressure relief valve may be open when the pressure in the tubing is about 30 psi for example. Optionally, a pressure sensor may be incorporated into the catheter or tubing set to monitor coolant pressure and signal a control console to adjust or stop flow of coolant or provide a warning. A second PTFE liner 524 defines a second lumen 543 dedicated for delivery of an ultrasound imaging catheter

526 and coolant outlet. The second lumen may have a shape and diameter (e.g., as shown) sufficient to allow passage of an imaging catheter 526 that may be for example about 8 FR to 10 FR (e.g., about 8.5 FR to 9 FR) and coolant while minimizing resistance to coolant flow. Alternatively, an imaging catheter lumen may be oval with a minor diameter sufficient to slidably fit an imaging catheter. Alternatively a catheter shaft may comprise a separate coolant return lumen. At the proximal end of the catheter shaft the imaging catheter may enter the second lumen through a hemostasis valve to stop coolant from leaking from the lumen and a coolant outlet port may be in communication with the second lumen to release coolant from the catheter to a drainage vessel or return it to a coolant supply vessel. The shaft may have a diameter in a range of about 11 FR to 14 FR (e.g., about 12.5 FR) and length sufficient to reach a target tissue from a vasculature introduction area. For example a catheter configured to be introduced in a patient's femoral vein and delivered to either a right or left internal jugular vein proximate a carotid septum may have a length in a range of about 90 cm to 130 cm (e.g., about 110 cm).

[0194] As shown in FIGS. 12C and 12D the first and second lumen liners 523 and 524 extend from the extruded tube to interface with the ablation transducer support component 512. The first liner delivers the wires 525 and coolant delivery lumen 542 to a section of the ablation transducer support component dedicated for housing 528 an ablation transducer 513, which comprises a wire management shelf 527, an indented housing 528 for mounting the ablation transducer assembly, a solder relief hole 529, and protective ridges 530. The second liner 524 is in communication with an imaging catheter lumen 531 of the ablation transducer support component and coolant return slots 532 of the ablation transducer support component. An imaging catheter delivered through the lumen 543 of the second liner 524 may pass through the imaging catheter lumen 531 of the ablation transducer support component and into the chamber 515. Coolant in the chamber may exit through the lumen 531 or coolant return slots 532 and pass through the lumen 543 of the second liner 524 to be removed from the catheter at its proximal region.

[0195] The ablation transducer support component 512 is connected to the catheter shaft 511 and is configured to hold an ultrasound ablation transducer 513 in a position relative to an imaging transducer 533 and direct flow of coolant fluid that stops the ablation transducer from overheating. As the ablation transducer vibrates heat is produced. The coolant passes over the ablation transducer to remove heat and maintain a temperature below a predefined maximum (e.g., about 90 degrees C.). An ablation transducer temperature that gets too hot may result in damage to the transducer or other components of the catheter or uncontrolled conduction of heat to the blood, vessel or other tissues. The temperature sensor may monitor transducer temperature to ensure coolant is flowing properly. If the temperature rises above a predefined maximum the console may respond by giving an error message, stopping delivery of ablative energy or adjusting delivery of ablative energy.

[0196] As shown in FIG. 12B, an exploded illustration of the ablation transducer support component 512 and ablation transducer assembly, the wires 525 may be soldered to the transducer 513. For example, the two wires of the high frequency current circuit may be soldered to opposing sides of the transducer and a constantan wire may be soldered to

the inward facing side of the transducer to create a thermocouple with one of the copper wires. The ablation transducer may be adhered to a transducer backing 534, for example with cyanoacrylate 535 and the backing may be adhered to the ablation transducer housing of the ablation transducer support component, for example with cyanoacrylate 536. UV adhesive 537 may be applied to the edges of the transducer assembly to further strengthen its bond to the ablation transducer support component. The solder relief hole 529 accepts the protruding solder joint and may be filled, for example with UV adhesive 538 once the transducer assembly is adhered to the ablation transducer support component to pot the solder joint creating an electrical insulation and mechanically strengthening the solder joint. The protective ridges 530 define a channel for coolant to flow over the ablation transducer to the echolucent imaging chamber 515 and maintain a space between the ablation transducer and an echolucent shell layer 539. If the catheter is pressed into an internal wall of a vessel, for example by deflecting a steerable delivery sheath, the protective edges maintain the space by stopping the soft, thin layer of the echolucent shell from collapsing. An ablation transducer may be a flat, rectangular piezoelectric transducer (e.g., about 0.004" thick, 2 mm wide, 6 mm long). Alternative embodiments of ablation transducer are exemplified herein, such as curved transducers or transducer arrays. The ablation transducer backing may be made from stainless steel having a thickness of about 0.008". Alternative backing designs are exemplified herein, such as epoxy filled with glass microspheres filled with air. Adhesive between the ablation transducer and backing may have a thickness that is in sync with the wavelength of the ablation transducer and may be a consistent thickness to allow for repeatable transducer assembly performance, for example, decoupling of the transducer from the backing. For example, the space between the transducer and backing may be greater than about 0.0013" (e.g., about 0.002") for a transducer having a resonant frequency in a range of about 20 MHz to 21 MHz. The space may be filled with adhesive. In an alternative embodiment a thin layer of material that is less dense than the backing such as polyimide may be placed between the ablation transducer and backing to maintain a consistent spacing to ensure the ablation transducer vibration is not significantly dampened by the backing material.

[0197] In an alternative embodiment a ablation transducer support component may be configured to create turbulent flow of coolant over and around an ablation transducer. For example, the ablation transducer support may have similar features to the ablation transducer support component 512 shown in FIG. 12B however it may further comprise ridges or bumps (not shown) in the coolant flow area such as on the sides of the protective edges 530, or lumens (not shown) in the sides of the protective edges to encourage coolant to flow more in the region of the sides of the ablation transducer.

[0198] The echolucent shell shown in FIG. 12A partially defines a hermetically sealed chamber and is configured to allow ultrasound waves to pass through it with minimal interference. The echolucent shell may be comprised of multiple layers for example an inner layer 540 may be a nylon extrusion having a thickness of about 0.005", which may provide sufficient strength to the distal assembly. The inner layer may be adhered to a shelf 541 of the ablation transducer support component. A second outer layer 539 may be for example a thin PET or nylon sleeve having a

thickness in a range of about 0.00025" to 0.0008". In an embodiment comprising an inner and outer layer made of nylon the layers may be melted together, which may eliminate air between the layers or a need for adhesive. Other materials that may be used for the first or second layers of the echolucent shell include PET or LDPE or other biocompatible materials having a relatively low acoustic impedance. As shown in FIG. 12A the outer layer extends over the ablation transducer support component and is bonded to the shaft 511 with adhesive. In this configuration the ultrasound imaging waves pass through the inner and outer layers and the ultrasound ablation waves pass through the outer layer only. A distal tip 518 is connected to the distal end of the echolucent shell and may have a rounded tip to facilitate delivery through a sheath and vessel and a shelf of decreased diameter for connection to the shell allowing a flush transition on the outer surface. The distal tip may be made from soft radio-opaque Pebax, which may be visualized when in use with X-ray or fluoroscopy.

[0199] In an alternative embodiment as shown in FIG. 12H an outer layer 550 may be a balloon (e.g., nylon) having a bulge 551 positioned in front of an ablation transducer 552, which may allow a larger fixed distance between the ablation transducer and vessel wall and better cooling compared to a shell without a bulge. The bulge may be approximately 1 mm offset.

[0200] In an alternative embodiment as shown in FIG. 12I an echolucent shell may comprise an outer layer 566 which may be a thin layer of substantially echolucent material (e.g., nylon, PET, LDPE) which may be less than 0.001" (e.g., about 0.008") and an inner layer may comprise two layers 567 and 568 that sandwich a fiducial marker 569. The two layers 567 and 568 may be about 0.0025" thick and be made of material such as nylon that in combination with the outer layer 566 may be substantially echolucent to ultrasound waves emitted by imaging transducer(s) of an imaging catheter 526.

[0201] In an alternative embodiment an echolucent chamber may contain an ultrasound ablation transducer but not an imaging transducer. An imaging catheter lumen may be configured to place an ultrasound imaging transducer of an imaging catheter in proximity to the ablation transducer but in contact with the blood stream. A fiducial marker may be positioned in the field of view of the imaging transducer and may be for example a guidewire.

[0202] A fiducial marker 516 may be placed in a pre-defined position relative to the direction of aim 517 of the ablation energy such that an artifact is created on an ultrasound-based image or video indicating relative direction of aim of the ablation energy with respect to anatomical structures imaged. As shown in FIGS. 12A and 12F the fiducial marker 516 may be a thin band of echo-opaque material (e.g., a curved strip that is about 0.080" wide, 0.002" thick and 0.5" long and laser cut from a stainless steel tube) sandwiched between the inner 540 and outer 539 layers of the echolucent shell and positioned radially opposite the direction of aim of ablation energy. An alternative design comprises two inner layers of nylon that are about 0.0025" thick wherein a fiducial marker is positioned between the two inner layers and the two inner layers are melted together embedding the fiducial marker. This may prevent the fiducial marker from damaging a thinner outer layer. Alternative embodiments of fiducial markers are disclosed herein.

[0203] At the proximal region of the ablation catheter the shaft may be connected to a proximal ablation transducer support, which may also function as a handle 544 as shown in FIG. 12G. The handle may have an electrical connector 545 to connect wires for the ablation transducer and sensor (s) (e.g., temperature sensor) to the ablation console 546 via an interconnect cable 547, a imaging catheter port 548 with a hemostasis valve, a coolant input port 549 and coolant output port 555 that connects to a coolant tubing set 556. The tubing set may connect to a coolant supply 561 through a pump (e.g., peristaltic pump) 562 and a coolant discard container 563. An ultrasound imaging catheter (e.g., IVUS catheter) 526 may be inserted in to the imaging catheter port 548 and connected to an imaging console 559, which may optionally be connected to an imaging augmentation algorithm and display 560 or the ablation console 546. The handle 544 may facilitate rotational manipulation of the ablation catheter. A non-volatile memory storage element 557 such as an EEPROM containing a unique lesion depth table with settings for time and power may be in the handle and connected to the electrical connector to communicate with the ablation console. The handle may comprise a circuit board 558 for managing electrical connections and containing the EEPROM and other electrical capabilities such as connected device detection, use limitation (e.g., re-use prevention, limited duration of use, limited number of uses), and an electrical matching circuit that will minimize reflected energy in the system. The ablation catheter 544 may be inserted into a deflectable delivery sheath 564.

[0204] Optionally the ablation catheter may further be configured with a means for deflection or delivery over a guidewire as exemplified by embodiments disclosed herein. Imaging Beam Aligned with Ablation Beam

[0205] An embodiment of a carotid body ultrasound ablation catheter may comprise a distal region that is delivered to a patient's vasculature and a proximal region that remains outside the body. The distal region is adapted to deliver ablative ultrasound energy from an ultrasound ablation transducer and ultrasound imaging signals from an ultrasound imaging catheter. The catheter is configured to provide an image of tissue proximate the distal region that is aligned and oriented with the direction of aim of the ablation transducer. The user may image tissue around the distal region to search for and identify a target ablation zone (e.g., an intercarotid septum), orient the catheter so the ablation transducer is aimed at the target ablation zone, and deliver ablative ultrasound energy to the target ablation zone. In FIG. 13, the distal region 320 comprises an echolucent shell 321, which may be a thin polymer or balloon for example. The cavity within the shell defines an echolucent chamber 322, which may be filled with a coolant (e.g., circulating saline or sterile water). For example, coolant may be delivered via coolant delivery lumen 332 and exit via coolant exit lumen 333. Within the echolucent chamber is an ultrasound ablation transducer 323 mounted to a backing 324, which is an ultrasound blocking material such as stainless steel or an epoxy containing microspheres of air. The ultrasound ablation transducer is aimed in a generally radial direction such that when ablative ultrasound energy is emitted it is delivered along the direction of aim 325. The ultrasound ablation transducer or backing may be mounted to the shaft 326, for example on a rod (e.g., hypotube) inserted in to a lumen in the ablation catheter shaft as shown or on an ablation transducer support component (not shown).

[0206] The carotid body ultrasound ablation catheter may comprise an elongate shaft 326, which may be made from an extruded polymer and may be a sufficient length (e.g., about 100 to 120 cm) to reach a patient's neck from a femoral vein when delivered through a vena cava to an internal jugular vein 12. Human internal jugular veins are typically about 8 to 20 mm in diameter. The shaft may be configured to fit in a jugular vein for example having a diameter of less than or equal to about 18 French (e.g., between about 9 and 11 French). The catheter may be delivered through a delivery sheath 327, a steerable delivery sheath, or over a guidewire 328. The shaft may comprise an Imaging catheter lumen 329 that slidably accepts an Imaging catheter 330. The lumen may extend from the proximal region of the catheter to the echolucent chamber at the distal region. The Imaging catheter may be inserted into the Imaging catheter lumen at the proximal region of the ablation catheter (e.g., in a handle) and advanced through the Imaging catheter lumen to the distal region. The Imaging catheter lumen may be oriented in the echolucent shell chamber such that the imaging transducer 331 of the imaging catheter is positioned along the direction of aim of the ablation transducer.

[0207] As shown in FIG. 14A at the proximal end of the catheter 334 the Imaging catheter lumen 329 may be accessible to an Imaging catheter 330, for example with a port 335 containing a hemostasis valve, and may comprise a mating feature 336 that mates with a mating feature 337 on a proximal end of the Imaging catheter so that when the Imaging catheter is fully inserted the mating features mate and the distal end of the Imaging catheter is positioned appropriately in the distal region 338 of the ultrasound ablation catheter. The mating feature on the Imaging catheter may be affixed to the catheter or it may be a separate adapter that is placed on the shaft of the Imaging catheter and tightened on a desired position to act as a depth stopper. The mating feature of the ablation catheter may be movable between a deployed position, shown in FIG. 14A and a retracted position shown in FIG. 14B such that in the deployed position the imaging transducer is aligned with the ablation transducer and ready for imaging a target; and in the retracted position the imaging transducer is pulled toward the proximal end of the ablation catheter enough to move the distal end of the Imaging catheter out of the direction of aim of the ablation catheter. An actuator 339 on a handle may be used to advance or retract the imaging catheter. Alternatively, an Imaging catheter may be manually advanced and retracted.

[0208] The ultrasound ablation catheter may further comprise a means to deliver coolant such as saline or sterile water to the echolucent chamber 322 of the distal region. For example, the shaft may comprise a coolant delivery lumen 332 and a coolant return lumen 333. The coolant delivery and return lumens may be connected to a coolant delivery 339 and coolant return 340 port at the proximal region of the ablation catheter. Coolant may be provided to the catheter by a coolant system comprising a coolant source such as a container of saline or sterile water, a conduit such as tubing, and pump such as a peristaltic pump. The coolant system may further comprise a flow pulsation damper or a flow meter. The coolant system may be controlled by the user or may be automatically controlled by a console 341 that coordinates delivery of coolant in coordination with delivery of ultrasound energy. For example, coolant may begin to circulate prior to delivery of ablation energy at a rate and

time sufficient to ensure coolant is circulating in the echolucent chamber before ablation energy is delivered and continues at least until the ablation energy is stopped. Other signals may also be used in the control of coolant such as temperature of the ultrasound ablation transducer or echolucent chamber for example.

[0209] The ultrasound ablation catheter may further comprise electrical conductors connecting the ablation transducer to an electrical connector at the proximal region of the catheter (e.g., on the handle). The conductors may be held in a lumen in the shaft or a lumen in the hypotube (not shown). Other conductors may be present such as sensor conductors. A temperature sensor may be positioned in the echolucent chamber (e.g., on the echolucent shell surface, on the ablation transducer surface), which may measure temperature. Temperature measurements may be used to indicate sufficient power, excessive power, or overheating. The temperature signal may be used to control power delivery to the ablation transducer.

[0210] An alternative embodiment as shown in FIG. 15B may comprise a machined ablation transducer support component 345 (shown in FIG. 15A), which may be made from a dense material such as stainless steel to act as an ablation transducer backing or the ablation transducer support component may be made from a plastic such as PEEK and a thin transducer backing may be added. The ablation transducer support component may be cylindrical with a cut away section that in combination with an echolucent shell 346 defines an echolucent chamber. An echolucent shell (e.g. a polymer sleeve, membrane or balloon with a thickness in a range of about 0.0002" to 0.009") is placed around the cut away section to form the echolucent chamber and contain circulating coolant. The ablation transducer support component has a means to bond to a polymer shaft such as a lip 347 that may have barbs or fenestrations that bind to the shaft 348 or holes to accept reflow of the shaft material. The ablation transducer support component comprises an imaging catheter lumen 349 in communication with the imaging catheter lumen in the shaft. An ablation transducer 350 may be mounted to the ablation transducer support component 345 as shown and the ablation transducer support component may have an indented housing 351 or outline where the ablation transducer is placed to facilitate fabrication. The ablation transducer support component may also comprise a coolant delivery 352 and return lumen 353 that are in communication with coolant lumens in the shaft when the ablation transducer support component is connected. The ablation transducer support component may also have a lumen to carry electrical conductors (e.g., to connect to the ablation transducer or sensor conductors such as temperature sensor). The distal end 354 of the ablation transducer support component may be rounded. The imaging catheter lumen may be positioned on the machined piece such that the center of the lumen lies on a direction of aim of the ablation transducer, which may be considered to be a perpendicular line to the ablation transducer face emanating from the center of the ablation transducer face. In the deployed state, the height of the imaging transducer 355 of an imaging catheter 358 may align with the direction of aim of the ablation transducer as shown in FIG. 15B.

[0211] Optionally, the ultrasound ablation catheter may comprise a means to be delivered over a guidewire 356. As shown in FIG. 13, 15A or 15B a catheter may comprise a

guidewire lumen 357 which may be on the side of the shaft or alternatively within the shaft.

[0212] An example of an image provided by an ultrasound imaging catheter deployed in an ultrasound ablation catheter is shown in FIG. 16. Cross-hatched areas represent dark areas of the ultrasound image including a wedge-shaped shadow 360 cast by the ablation transducer or backing material, the vessel 361 containing the catheter (e.g., internal jugular vein, facial vein), an internal carotid artery 90 and an external carotid artery 91. The direction of aim 362 of the ablation transducer is opposite to the shadow cast by the ablation transducer and through the center of the artifact of the ultrasound imaging catheter 363. The orientation of the ablation catheter, as shown, places the direction of aim 362 of the ablation transducer toward the carotid septum 205, which is between the internal and external carotid arteries and may be within about 7 or 10 mm superior from the carotid bifurcation. The carotid bifurcation may be identified as the catheter is advanced through the vessel (e.g., internal jugular vein, facial vein) and the internal and external carotid arteries converge. The distance from the carotid bifurcation may be determined, for example by advancing the catheter within about 7 mm which may be measured by depth markers on the shaft of the carotid body ultrasound ablation catheter in relation to a delivery sheath (not shown). Once the orientation and position of the ablation catheter is placed as desired with the direction of aim of the ablation transducer directed at the target area, the ultrasound imaging catheter may be retracted so the distal end of the ultrasound imaging catheter is removed from the echolucent chamber, or at least out of the way of the ablation signal, and ultrasound ablation energy may be delivered from the ablation transducer to the target area.

[0213] The ultrasound ablation catheter may further be adapted to articulate the distal region. Articulation may facilitate positioning of the ablation transducer in alignment with a target or expanding an ablation zone by creating multiple ablations associated with multiple positions of articulation. For example, the ablation catheter may comprise controllable deflection wherein a deflectable length 366 (e.g., about 1 to 3 cm) is bent from side to side up to a deflectable distance 367 (e.g., about 0.5 to 3 cm). Deflection may be in a plane that is coplanar with the ablation transducer as shown in FIG. 17. Controllable deflection may be achieved with pull wires connected to the distal region 368 (e.g., to an ablation transducer support component), the pull wires passing through lumens in the shaft to the proximal region where they may be connected to a deflection actuator 369 on a handle 370 that applies tension to a pull wire to deflect the distal region. The deflectable catheter may comprise a means to rotate the catheter shaft such as a rotation actuator 371.

[0214] Deflection may be configured in a plane that is substantially orthogonal to the plane of the ablation transducer or in any other direction which may facilitate placement of the treatment transducer, creation of multiple ablations, creating a larger ablation, or maneuvering or deforming a vessel (e.g., vein, jugular vein, facial vein) that contains the catheter to place the ultrasound ablation transducer in a suitable position to deliver energy to a target or to place the ultrasound imaging transducer in a suitable position to identify the target or tissues in the area of the target.

Angled Ablation Transducer

[0215] An alternative embodiment of an ablation catheter 375 configured for ultrasound imaging and therapy, as shown in FIG. 18, may comprise an imaging catheter lumen 376 configured to accept a separate ultrasound imaging catheter (e.g., IVUS or ICE catheter) 377 wherein the imaging transducer 378 is advanced into an echolucent chamber 379 in the distal region of the ablation catheter, and an ablation transducer 380 positioned in the echolucent chamber distal to the imaging transducer and angled so that the emitted ultrasound ablation energy is directed to cross the imaging plane 381. The imaging plane may be a disc approximately perpendicular to the axis of the imaging catheter. Alternatively, an imaging catheter may be configured to angle imaging transducer(s) slightly (e.g., about 85 degrees from the imaging catheter axis instead of perpendicular to the axis) creating a slightly conical imaging slice. In FIG. 18 the ablation transducer 380 is positioned distal to the imaging transducer(s) and angled so that an ablation 382 created is directed to intersect the imaging plane or slice. Alternatively, an ablation transducer may be positioned proximal to the imaging transducer(s) and angled so that an ablation is directed to intersect the imaging plane or slice. The ablation transducer may be rectangular, have rounded corners, or be ovoid or circular. For example, in an embodiment configured to ablate a carotid body or carotid septum, the ablation may intersect with the imaging plane approximately 3 to 8 mm (e.g., about 5 mm) away from the surface of the imaging catheter, which may be a suitable distance from the catheter positioned in a jugular vein 12 or facial vein to the target area 205. An example configuration may comprise an ablation transducer that is 4 mm long and 2 mm wide. The ablation transducer may be placed at an angle 383 of between approximately 40° to 50° (e.g., about 45° to the axis and at a distance 384 of about 3 to 10 mm (e.g., about 5 mm) distal to the imaging plane. An ablation zone may be created that has an elongated shape extending substantially perpendicular to the face of the ablation transducer. Benefits of this embodiment may include the ability to image a target zone while delivering ablation energy, or imaging a target zone then delivering ablation energy without having to move the imaging catheter, which may improve safety and efficacy by reducing a risk of moving the ablation energy off of the target. Furthermore, an angled ablation in a target zone may encompass a larger volume of the target zone while not extending beyond the target zone. An angled ablation transducer placed distal to an imaging transducer may allow for a reduced catheter diameter. In a similar embodiment an imaging transducer may be integrated into the ablation catheter instead of being a separate catheter advanced into the ablation catheter.

[0216] In the embodiment shown the ablation catheter 375 comprises a shaft (e.g., having an outer diameter of about 11 F), made from extruded polymer with a soft durometer with a braided jacket layer for improved torque response. The shaft comprises an imaging catheter lumen 376 (e.g., about 9.5 F) used to receive an ultrasound imaging 377 catheter. This lumen may also be used for passage of coolant. The ablation catheter may also comprise a guide wire lumen 385 (e.g., having a lumen diameter to slidably contain a 0.018" guidewire) for Over-The-Wire catheter delivery. The guidewire lumen may be a lumen in a tube (e.g., polyimide tube) passed through a lumen in the shaft and through the echolucent chamber to the distal end of the catheter. The ablation

catheter may comprise a coolant delivery lumen, which may be a lumen in a coolant delivery tube that deposits coolant such as saline or sterile water in the echolucent chamber (e.g., distal to the ablation transducer). Coolant may flow within the echolucent chamber and out of a coolant exit lumen, which may be the imaging catheter delivery lumen. A temperature sensor (e.g., thermocouple, thermistor) may be placed within the echolucent chamber (e.g., on the ablation transducer, on the wall of the chamber) to monitor temperature and ensure sufficient coolant is delivered to avoid overheating. An aiming marker 386 may be positioned in the imaging plane next to the imaging catheter delivery lumen and opposite the direction of the delivery of ablation energy. The aiming marker may be made from a material that interacts with the imaging ultrasound waves to create a distinctive image on an ultrasound-based video. For example the aiming marker may be made from a material that absorbs ultrasound waves or that is a strong reflector of ultrasound waves. A distinctive image, or artifact, representing the aiming marker shown on an ultrasound-based video may be a shadow or highlight indicating that the ablation transducer is aimed in the opposite direction. Other configurations may be envisioned that create an unambiguous identification of the direction of aim.

[0217] An example of a method of use may comprise advancing a sheath 387 to a region proximate a target; advancing an ablation catheter 375 within a lumen of the sheath; advancing an imaging catheter in the lumen of the ablation catheter until the imaging transducer(s) is positioned in the echolucent chamber; deploying the ablation catheter containing the imaging catheter from the distal end of the sheath; while imaging with the imaging catheter using a combination of advancing and retracting the sheath together with the ablation catheter containing the imaging catheter and deflecting and torquing the sheath to obtain a suitable position relative to the ablation target; torquing the ablation catheter while imaging to aim the ablation transducer at the target. Optionally, a guide wire may be used. For example, a guidewire may be delivered first and the sheath and catheter may be delivered over the guidewire.

Angled Imaging Transducer

[0218] An alternative embodiment comprises an imaging transducer(s) 390 that is positioned at an angle to the ablation catheter shaft 391. A separate ablation transducer 392 may be parallel to the ablation catheter shaft or angled as shown in FIG. 19. The ablation and imaging transducer(s) are placed at a distance along the catheter axis from one another and they are at an angle to one another so that ablation 393 and imaging 394 zones are overlapping at a distance radial to the ablation catheter that is suitable for ablation 395 of a target from a vessel 12 (e.g., ablation of a carotid body target from a vein such as a jugular or facial vein). In the embodiment shown, an imaging catheter 396 is advanced through a lumen in the ablation catheter. In the distal region of the catheter the lumen bends and exits through a port 397 on the side of the catheter. The imaging catheter passes out the port and the imaging transducer(s) 390 on the imaging catheter are positioned at an angle to the ablation catheter shaft. Overlapping imaging and ablation zones allow for simultaneous imaging and ablation of a target. The angle between the imaging and ablation transducers may be dictated by ablation catheter diameter, distance between the ablation and imaging transducers and

intended ablation size. This angle may be for example between about 90° and 150°. This embodiment may allow for an ablation catheter having a smaller diameter than a design having ablation and imaging transducers positioned next to one another and on a substantially same axial position. This embodiment may also allow for using imaging catheters that have a long section distal to its imaging transducers that inhibits suitable alignment of imaging and ablation transducers. The long distal section may protrude out the lumen's exit port.

[0219] Since the distance between a vein and a target area may vary the vein may be manipulated as described herein to achieve suitable position and distance. Alternatively, an ablation catheter may be configured to angle the ablation transducer to achieve an ablation at an appropriate distance. For example, multiple catheters may be provided that are configured for creating an ablation at varying distances and angles from the ablation catheter.

Pivoting Ablation Transducer

[0220] An embodiment of an ultrasound ablation catheter **400** configured to accept an imaging catheter **358** may have an ablation transducer **401** that may pivot to alter the angle **402** with the axis, as shown in FIGS. **20A** and **20B**. A user may control the pivot via an actuator on the proximal end of the catheter (e.g., a lever, dial, button, or knob on a handle) that for example, applies tension to a pull wire that pivots the transducer from one angle to another or to multiple positions between. As shown in FIG. **20A** the ablation transducer **401** is positioned next to the deployed imaging transducer(s) **355**. In this arrangement the device may be used in multiple ways depending on the anatomy and position of the catheter. Alternatively, the ablation transducer may be positioned distal to the deployed imaging transducer as shown in FIG. **20B**. The pivoting mechanism may comprise a hinge or pivot hinge **403** at the proximal end of the transducer backing. A spring may urge the transducer to a first position (e.g., at an angle of about 45 degrees to the axis). A wire that is slidable held in a lumen of the catheter and connected to an actuator on the proximal end of the catheter may be pushed to engage and straighten the pivoting transducer or pulled to remove engagement with the transducer allowing it to spring to its angled configuration. The angle of the ablation transducer or relative position of the ablation transducer and imaging transducer may be adjusted to move an intersection of the ablation beam **404** and imaging plane **405**.

Imaging Catheter Compatibility

[0221] An ablation catheter may be configured to be used in conjunction with a separate imaging catheter, which can help a user identify tissue of and around a target ablation zone in order to deliver ablation energy safely and effectively to the ablation target. The separate imaging catheter may be for example an ultrasound imaging catheter such as an Intravascular Ultrasound (IVUS) catheter or Intracardiac Echocardiography (ICE) catheter. The imaging catheter may comprise enhancing technology such as photoacoustic or thermoacoustic imaging. Other medical imaging technology may be suitable.

[0222] A variety of IVUS and ICE catheters are available on the market. An ablation catheter configured to accept an ultrasound imaging catheter may be particularly configured

to accept an imaging catheter available on the market, such as the Visions® PV 0.035 IVUS catheter by Volcano, or the UltraICE™ catheter by Boston Scientific Corporation.

[0223] A Visions PV 0.035 IVUS catheter has an imaging transducer on its distal region. The imaging plane is about 13.5 mm from the very distal end. The transducer is 8.2 FR in caliber and about 6.5 mm long. The distance from the proximal end of the transducer to the very distal end of the catheter is about 18.5 mm. The catheter shaft is 7.0 FR and the working length is about 90 cm. The imaging transducer is made of a 64-element cylindrical array. The catheter has a guide wire lumen running from its distal tip to proximal end. An ablation catheter configured to accept a Visions PV 0.035 IVUS catheter may comprise an Imaging catheter lumen having a minimal diameter about 8.5 FR and preferably with additional room for coolant return in the same lumen around the IVUS catheter. The space in the echolucent chamber may be long enough to contain the imaging transducer and portion of the catheter that is distal to the transducer. For example the distance from the distal edge of the ablation transducer support component to the end piece may be at least 18.5 mm (e.g., about 19 mm). The length of the ablation catheter may allow the imaging transducer to be positioned in the echolucent chamber while the Y-connector on the IVUS catheter's proximal end extends from the proximal end of the ablation catheter (e.g., from a handle on the proximal region). For example, the length of the ablation catheter from the distal end to the IVUS port on the proximal end may be no more than about 90 cm yet long enough to reach the target area (e.g., in a jugular vein near a carotid body) from an introduction site (e.g., femoral vein) while inserted through a deflectable delivery sheath. A valve such as a hemostasis valve on the IVUS port of the ablation catheter should be configured to allow passage of the 8.5 FR transducer while sealing around the 7 FR shaft to stop coolant from leaking for example up to a pressure of about 30 psi. The guidewire lumen of the IVUS catheter may be primed with coolant and sealed with a luer cap at the proximal end to stop coolant from leaking or air from entering.

[0224] An UltraICE™ catheter has a single 9 MHz imaging transducer mounted to a rotating drive shaft that passes through the catheter's shaft to the proximal region where it is connected to a motor to spin the transducer. The transducer is angled slightly toward the distal end. The imaging plane is about 5.5 mm from the very distal end. However, since the transducer is angled the image is a slightly distal looking cone rather than a transverse plane. The transducer is 9 FR in caliber and about 2 mm long. The distance from the proximal end of the transducer to the very distal end of the catheter is about 9.5 mm. The catheter shaft is 9 FR and the working length is about 110 cm. An ablation catheter configured to accept an UltraICE™ catheter may have an Imaging catheter lumen having a minimal inner diameter of about 9 FR and preferably with additional room for coolant return in the same lumen around the ICE catheter. The space in the echolucent chamber may be long enough to contain the imaging transducer and portion of the catheter that is distal to the transducer. For example the distance from the distal edge of the ablation transducer support component to the end piece may be at least 9.5 mm (e.g., about 10 mm). Consideration should be given to how the angle of the imaging transducer alters the position of the target relative to the image. The length of the ablation catheter may allow

the imaging transducer to be positioned in the echolucent chamber while the connector on the ICE catheter's proximal end extends from the proximal end of the ablation catheter (e.g., from a handle on the proximal region). For example, the length of the ablation catheter from the distal end to the imaging catheter port on the proximal end may be no more than about 110 cm (e.g., about 104.5 cm+/-2 cm) yet long enough to reach the target area (e.g., in a jugular vein near a carotid body) from an introduction site (e.g., femoral vein) while inserted through a deflectable delivery sheath (e.g., having a useable length of about 93.5 cm+/-2 cm). A valve such as a hemostasis valve on the imaging catheter port of the ablation catheter should be configured to allow passage of the 9 FR shaft while sealing around it to stop coolant from leaking for example up to a pressure of about 30 psi. Since the imaging transducer rotates on a drive shaft caution should be taken to avoid pinching the drive shaft or impeding its rotation. For example the ablation catheter may be configured to have minimal bend radius or tortuosity. A component may be provided that contains the motor drive and proximal region of the ICE catheter relative to the proximal region of the ablation catheter to avoid kinking.

System

[0225] A system to support the ablation catheter may comprise an interconnect cable, a delivery sheath, a coolant tubing set, a coolant pump, and an ablation console. For embodiments configured to accept a separate imaging catheter the system may include an imaging catheter and imaging console or these may be provided separately. For embodiments configured with an integrated imaging transducer an imaging console may be integrated with the ablation console or a separate unit. Other components, such as coolant (e.g., sterile water or saline in an IV bag or bottle), introducers, site preparation supplies, and dressings, used in the procedure may be provided in a kit or procured from a procedure facility's supplies. A system may also comprise a brace to hold a patient's head and neck still relative to the torso. For embodiments configured for use with a guide wire a system may comprise a guidewire or a set of guidewires (e.g., guidewires having 0.018" diameter or 0.035" diameter, guidewires with preformed bends, deflectable guidewires).

[0226] The interconnect cable may be configured to connect the ablation catheter to the ablation console, for example with mating quick-connect connectors and suitable conductors. The interconnect cable may be a suitable length (e.g. about 8') to separate the ablation console from the sterile field and not impede catheter maneuverability during the procedure.

[0227] The delivery sheath may deflectable in at least one direction. It may have a soft (e.g., about 35 D durometer) atraumatic tip, a lumen with a diameter suitable to slidably fit the ablation catheter (e.g., about 0.174"), a corresponding outer diameter (e.g., about 0.210"), and a valve to allow passage of the ablation catheter (e.g., a Tuohy-Borst valve).

[0228] The coolant tubing set may be compatible with the coolant pump, for example having a section that feeds through and functions with a peristaltic pump. The coolant tubing set may comprise luer lock connections that are compatible with commercially available IV solution administration sets and extension sets. The tubing set may comprise a tube that delivers coolant from a pump tube section to the coolant delivery port of the ablation catheter's handle. This section of tube may further comprise a pressure relief

valve to open in case of inadvertent high pressure for example caused by catheter occlusion. This section may further comprise a pulsation damper. The coolant tubing set also comprises a coolant return tube to be connected to the coolant return port of the ablation catheter handle. The coolant return tube may return coolant to the coolant storage vessel or discard it. In one embodiment the coolant storage vessel only contains enough coolant sufficient for a limited number of ablations and return coolant is discarded so in the case of a catheter leak only a limited amount of coolant is delivered to the patient's blood stream.

[0229] The ablation console may be a computerized electrical signal generator that delivers high frequency (e.g., in a range of about 10 to 25 MHz, about 20 MHz) alternating current to an ultrasound ablation transducer. Parameters of the delivered energy may be selected by a user or may automatically be determined. For example, the console may read data from memory in a catheter and deliver energy accordingly or in combination with a desired parameter such a lesion depth. The console may also coordinate coolant pumping or imaging capabilities. The console may identify conditions that indicative of a malfunctioning catheter or undesired procedure and alert a user or adjust energy delivery to mitigate the problem. A console may be configured to deliver nerve stimulation signals to a catheter. For example, an ultrasound signal that mechanically or thermally stimulates a nerve may be delivered without ablating tissue to confirm effective or safe aim of an ablation transducer prior to delivery of ablation energy and following ablation to confirm successful ablation. Alternatively, a catheter may comprise one or more stimulation electrodes and the console may deliver an electrical nerve stimulation signal to assess proximity to a nerve.

Manipulation of a Vein to Obtain a Suitable Ablation Position

[0230] Configuration of veins near a target site may vary from patient to patient or side to side within a patient. An ablation catheter **411** such as any of the embodiments of ultrasound ablation catheters disclosed herein may be delivered to a vein **12** that is near a target site **205** and in a suitable position for a carotid body ablation procedure. For example, conditions for a suitable position may comprise the distance **410** from an interior surface of a vein wall to a border of a target site such as an intercarotid septum to be within about 0 to 5 mm and alignment of the vein **12** with the target to allow delivery of ablative energy without obstruction or unsafe interference. Alternative conditions for a suitable position may depend on the configuration of the ablation catheter. In some patients there may not be a vein in a suitable position, however, an ablation catheter may be delivered to a vein that may be maneuvered to a suitable position. Maneuvering a vein, or a catheter within a vein, to a suitable position may comprise techniques such as palpating the neck, rotating the head, deflecting a deflectable ablation catheter, deploying a structure from an ablation catheter such as the deployable wire, deflecting a deflectable sheath, or a combination of these.

[0231] A deflectable sheath **412**, as shown in FIGS. **21A** to **21B**, may be configured for deflection in at least one direction, have an outer diameter of about 9 FR to 16 FR and have an inner lumen to slidably engage an ablation catheter **411**. The sheath may have an elongate section **413** and a deflectable section **414** with a central lumen running

through. A braided jacket may surround the elongate section to improve torque response. Active deflection may be accomplished by a pull wire running through a pull wire lumen in the sheath from a handle on the proximal end to an anchor at the distal end of the deflectable section. Tension may be applied to the pull wire by an actuator on the handle. The handle may also facilitate torquing manipulation and comprise a lumen to accept the ablation catheter with a clamping adapter such as a Tuohy-Borst connector. The sheath may comprise a deflectable section **414** near or at the distal region of the sheath. The deflectable section may be for example between about 1 to 5 cm long (e.g., about 3 cm long) and be positioned at the distal end of the sheath as shown in FIGS. **21A** and **21B**.

[0232] FIG. **21A** shows an ablation catheter **411** delivered through a deflectable sheath **412** in an undeflected state to a jugular vein **12** wherein the target tissue **205** is not sufficiently close to the ablation transducer **415**. FIG. **21B** shows the deflectable sheath **412** in a deflected state, which presses the ablation catheter **411** into the vein wall and manipulates the malleable vein to obtain a suitable distance **410** between the target tissue and ablation transducer. In such a configuration the ablation catheter **411** may have a bendable section **416** that bends to allow the catheter distal to the bendable section **416** to align with the vessel wall yet stiff enough to apply a force to the vein to manipulate its position. For example the bendable section **416** may have a durometer in a range of about 40 D to 55 D (e.g., about 50 D). Alternatively the bendable section may be characterized to have a bending stiffness of about $1.25 \text{ N} \pm 0.38 \text{ N}$ when spanned across 50 mm and deflected to -2.5 mm (5% of span length) with no imaging catheter in place. During use the length of the bendable section may be adjusted by advancing or retracting the catheter **411** from the delivery sheath **414**. By reducing the length of the bendable section bending stiffness may be increased allowing greater pressure to be applied to the vessel wall or to allow adjustments of the tilt of the rigid section containing the ablation transducer **415** and imaging transducer(s).

[0233] Alternatively, as shown in FIG. **21C** a deflectable section **421** may be near a distal region of a deflectable sheath **420** and a soft passively deflectable section **422** may be at the distal end of the sheath. The soft, passively flexible section may provide an atraumatic contact with a vein wall while the sheath is deflected into the wall to manipulate the vein into a suitable position for carotid body ablation. The soft, passively flexible section may also allow the distal opening of the sheath to be aligned with the vein so that an ablation catheter delivered through the sheath exits the sheath sufficiently parallel to the vein wall as shown. The soft, passively flexible section may be made of a softer durometer (e.g., about 35 D durometer) polymer than the elongate section (e.g., about 63 D durometer) and the deflectable section (e.g., about 50 D durometer). The length of the passively flexible section may be in a range of about 1 to 3 cm (e.g., about 2 cm). The length of the deflectable section **421** may be in a range of about 2 to 5 cm (e.g., about 3 cm).

[0234] A method of using a deflectable sheath with an ablation catheter may comprise delivering a sheath from an entry vein such as a femoral vein to a vein proximate to a target, e.g., in an internal jugular vein, a facial vein, or other vein connected to a jugular vein that is in proximity to a carotid body. A catheter such as the embodiments described

herein of ablation catheters or ablation catheters configured to be used with imaging catheters may be delivered through the deflectable sheath. An imaging modality such as an ultrasound imaging catheter positioned in an ablation catheter, or imaging transducers integrated with an ablation catheter, or a transducer configured to both image and ablate may be used to image tissue around the ablation catheter and identify a relative position of a target. If the vein needs to be manipulated to achieve a suitable position for ablation of the target the following steps or combination of steps may be conducted: the deflectable section of the sheath may be deflected by controlling an actuator; the sheath may be torqued at the proximal end or handle to torque the distal deflectable end; the ablation catheter may be advanced or retracted in the sheath to obtain a suitable distance from the sheath's deflectable section to the ablation transducer; the ablation catheter may be torqued at its proximal end or handle to rotate the direction of aim of ablation; and if the ablation catheter is configured to be deflectable it may be deflected. Imaging may continue while manipulating the vein or imaging may be intermittently performed until a satisfactory position is obtained. Adjustments to the position and direction of aim of ablation may be made during or after the vein has been satisfactorily manipulated. For example, the ablation catheter may be rotated, advanced, retracted or deflected to aim ablation energy toward the target while imaging.

Transducer Assembly Configured for Both Imaging and Ablation

[0235] An ultrasound ablation catheter may comprise a transducer assembly that is configured for both imaging and ablation. As shown in FIG. **22A** a transducer assembly configured to allow imaging and ablation capabilities may comprise a first transducer **425**, a second transducer **426**, a backing member **427**, and electrical conductors A, B, and C connected to the first and second transducers as shown. As shown in FIG. **22B** high power ablative vibration of the first transducer may be achieved by applying an RF signal to electrodes A and B in a frequency that is proportional to $1/a$ (e.g., about $v/2a$), where v is the speed of sound in the first transducer and a is the thickness of the first transducer. The second transducer, which may be one or multiple transducers, is sandwiched between the first transducer and the backing member providing a function of mounting the first transducer and imaging capabilities. The imaging at a lower frequency that is proportional to $1/(a+b)$ (e.g., of about $v/2(a+b)$ or $v/2b$), where b is the thickness of the second transducer, is achieved by sensing the vibration of the transducer assembly through electrode pairs AC or BC respectively. The backing member of thickness c , where c is greater than a or b predominantly serves as a reflector in ablation mode and as an absorber in imaging mode. The outer surface of the backing member has surface features (e.g., texture, angled ridges) that scatters and redirects incoming signals away from the imaging transducer area thus reducing the ringing effect inside the backing member. The inner surface of the backing member may be flat and mirror polished to enhance reflectivity at an ablation operation frequency of about $v/2a$. The optional gap between the backing member, not otherwise contained by the second transducer, and the first transducer may be filled with air or liquid.

[0236] For example embodiments of ultrasound ablation catheters with integrated imaging transducers such as those shown in FIG. 5A, 5B, 6A, 6B, 7A, 7B, 7C, 8A, 8B, 8C, 8D, 34A, 34B, 34C, 35, 36, 38, 39, 40, 41A, 41B, 41C, 42, 43A, 43B, 43C, 43D, 44A, 44B, 44C, 45A, 45B, 45C, 45D, or 45E may comprise a set of imaging transducers as shown but instead of an ablation transducer the catheter may have a transducer assembly that can both image and ablate. This may allow the transducer assembly to generate an image of tissue precisely where the ablation will be directed. Likewise embodiments of ultrasound ablation catheters configured to accept a separate ultrasound imaging catheter such as those shown in FIGS. 11, 12A to 20 may comprise a transducer assembly configured for both ablation and imaging.

[0237] Alternatively, as shown in FIG. 23 an ablation catheter 430 may be absent a set of imaging transducers or a means for accepting a separate ultrasound imaging catheter and only have a transducer assembly (FIG. 22B) 424 configured for both imaging and ablation. In such a configuration it may be more difficult to see tissue surrounding the target compared to embodiments with separate imaging abilities but such a configuration may have an advantage in terms of cost and ease of use. Since the single transducer assembly has an ability to produce an amplitude mode line image compared to embodiments having circumferential imaging capabilities, a user may manipulate the catheter, for example by torquing the catheter to sweep the transducer assembly side to side or advancing and retracting the catheter to obtain multiple line images of surrounding tissue. Alternatively a catheter may be configured to remain motionless while a transducer assembly with imaging and ablation functions is aimed in different directions from within the catheter. For example, the transducer assembly may be mounted to a rod passing through the catheter shaft that may be rotated 360 degrees or tilted within a predefined aperture, for example, within 90 degree angle. Alternatively the transducer assembly may be moved in multiple planes (e.g., pitch, yaw, swivel) from within the catheter. Such motion may be used to capture images of tissue surrounding the target, or to aim the transducer assembly at a target, or to move the transducer assembly to make multiply ablations, or sweep the transducer assembly to enlarge an ablation. The embodiment having a transducer that both images and ablates shown in FIG. 23 may optionally be further be configured to be delivered over a guide wire, or through a deflectable delivery sheath; be configured to manipulate position of a vessel (e.g., jugular vein or facial vein) as shown in FIGS. 21A and 21B; be configured to be cooled with sterile water or saline wherein the transducer may be electrically insulated as described herein and illustrated in FIGS. 44A, 44B, and 44C; be configured to be used without a delivery sheath, for example having multiple deflection or rotation capability for manipulating a vessel position relative to a target zone and aligning the imaging and ablation transducer with landmarks or targets as shown in FIGS. 39, 40, 41A, 41B, 41C, and 42, or for example comprising a retractable transducer protector as shown in FIGS. 43A, 43B, 43C, and 43D; be configured with an expandable echolucent membrane as shown in FIG. 35; be configured with a weeping membrane as shown in FIG. 36.

Ultrasound Ablation Dosimetry and Depth Control

[0238] The authors have conducted bench and animal studies to assess dosimetry of ultrasound ablation energy

using transducers with the size of about 2 mm in width and 4 mm to 6 mm in length. A power between 3 to 8 acoustic watts, a frequency in a range of about 10 MHz to 25 MHz and a time range of between 5 s to 20 s may allow a reasonable controllable lesion depth between 2 mm and 9 mm and lateral dimensions determined by transducer width and length suitable for targeting a carotid septum from a jugular vein (e.g., tissue residing at about 2-9 mm from the inner wall of the jugular vein).

[0239] The ability to control ablation depth is critical for the efficacy and safety of clinical procedure. In light of significant anatomical variation in relative location of the carotid arteries, carotid body and jugular vein, ablation depth control is essential for effective ablation of target tissue (e.g., carotid septum) while safely containing an ablated region to avoid iatrogenic injury of important non-target nerves or tissues. From the lesion formation theory a region of thermal coagulation induced by ultrasound heating is defined as an integral of temperature exponent over time [Sapareto S. A., Dewey W. C. Thermal dose determination in cancer therapy Int. J. Radiat. Oncol. Biol. Phys. 1984. V. 10. NQ Bi P. 787-800]. A lesion produced by a flat rectangular element starts closest to transducer and propagates to deeper tissue that is more distant from the transducer along the ultrasound beam, depth over time. Using the thermal dose definition the theoretical lesion depth may be approximated by an integral over time:

$$d \sim \int_0^t e^{T} dt \quad (1)$$

[0240] Where d is depth of the lesion, T is tissue temperature, t is time. Based on finite element simulation the tissue temperature over time is roughly proportional to a product of applied acoustic power and ablation time:

$$T \sim P t^{\beta} \quad (2)$$

[0241] Where β is a tissue and transducer dependent dimensionless coefficient less or equal to one. Combining equations (1) and (2) in a simplest case of $\beta=1$, applicable for active ultrasound power deposition with negligible volumetric thermal conduction, the lesion depth as a function of applied acoustic power and ablation time is given:

$$d \sim \frac{e^{Pt}}{P} \quad (3)$$

[0242] The more complex forms of lesion depth growth over time can be deduced assuming β deviates from unity, which corresponds to an ablation consisting of longer time and lower power in which thermal conduction effects cannot be neglected. Finite modeling of lesion formation provided theoretical data to evaluate different β coefficients and deduce the trend between applied acoustic energy and lesion depth. It was found that lesion depth and applied acoustic energy are best described by hyperbolic cosine function:

$$E = Pt = \alpha \cosh(\gamma t) = \alpha \frac{e^{\gamma d} + e^{-\gamma d}}{2} \quad (4)$$

[0243] Where lesion growth parameter a is minimum acoustic energy required to initiate lesion nucleation and γ is a characteristic lesion inversed depth parameter dependent on the transducer geometry, frequency and surrounding tissue anatomy.

[0244] The authors have determined through anatomical studies that a range of target ablation depths between about 2 mm to 9 mm may be suitable for delivering ablation energy to a carotid septum from a catheter placed in a jugular vein. Based on above theory, bench and animal studies the authors have demonstrated that a catheter delivering ablative energy from an ultrasound ablation transducer with a resonant frequency of about 21+/-2 MHz approximately 1 mm in lesion depth is gained for every 10 acoustic Joules of energy in a first approximation consistent with equation (3). Energy is a product of acoustic power and duration thus various regimes of controlling energy delivery parameters may be used to control ablation depth. For example, energy delivery parameters may be chosen to optimize multiple variables such as: minimizing duration to reduce risk of patient movement; utilizing a duration-power range in which lesion width or height are fairly consistent; utilizing a duration that is not too fast for a user or console to react to an event requiring adjustment of energy delivery for safety reasons; using a power that is not too high to have increased incidence of overheating; using a power that results in a reasonable transducer temperature increase that can be managed by coolant flow; minimizing duration to minimize conductive heating of adjacent tissues; utilizing parameters that allow control of lesion depth to about 0.5 mm precision.

[0245] A user may determine a desired ablation depth for example by assessing images from the ultrasound-based video created by the imaging transducer(s) that may have reference dimensions, and select the desired ablation depth on the ablation console. Alternatively, a computerized algorithm may assess a desired ablation depth automatically, for example based on the ultrasound-based video data, and relay the desired ablation depth to an ablation control algorithm of the ablation console. Alternatively, a computerized algorithm may assess relative positions of anatomical features such as internal and external carotid arteries and jugular vein and the ablation transducer and suggest a desired ablation depth to a user who may confirm or adjust the desired ablation depth to be entered into an ablation control algorithm. The ablation control algorithm may deliver ablative energy using energy delivery parameters suitable for creating the desired ablation depth.

[0246] Using computer finite element modeling the authors have calculated dynamic temperature profiles for sets of ablation time (e.g., duration of energy delivery) and applied acoustic powers. Computed lesion parameters were consistent with experimental results and the theoretical trend expressed by equation (4). The results 571 of finite element modeling of lesion depth versus energy is shown in FIG. 24A. The line 570 shows the theoretical trend by equation (4) with lesion growth parameters: $\alpha=3$ Joules and $\gamma=0.5$ mm⁻¹.

[0247] The accumulative effect of temperature is a thermal dose derived from the amount of energy deposited, which correlates with lesion formation dynamics. Determined predominantly by transducer dimensions the lesion lateral dimensions (e.g., length and width) increased relatively quickly and plateaued while lesion depth increased more slowly. Lesion width and length may be considered substan-

tially constant within a range (e.g., a range of about 5 s to 25 s) of ablation duration considered in the sets of power and time used to control lesion depth. The 2 mm deep lesion is considered to be the minimum controllable lesion depth of desired lateral dimensions consistent with the transducer lateral dimensions (e.g., 2 mm wide and 4-6 mm long). For each set of ablation time and power, lesion depth was modeled creating a plot and equation (4) representing the relationship between lesion depth and applied acoustic energy as shown in FIG. 24B.

[0248] The generic theoretical relationship between lesion depth and acoustic energy was confirmed using bench test studies using a polyacrylamide gel phantom that produced data points of lesion depth for power-time sets, which were used to create a relationship of lesion depth as a function of energy that closely resembled the theoretical relationship. In overall, the theoretical relationship expressed by equation (4) provided an accurate fit to both simulated (dotted line 573) and experimental (circles 574 and solid line 572) data. Computer simulations predicted nucleation energy $\alpha=3$ J and characteristic inverse depth constant $\gamma=0.5$ mm⁻¹, while experimental data yielded larger $\alpha=17$ J and smaller $\gamma=0.3$ mm⁻¹. The difference in deduced lesion growth parameters reflects difference in thermal dose assumed in simulation versus visually detectable lesion formation in polyacrylamide gel. Gel turns opaque at slightly higher 70° C. temperature and has zero perfusion compared to typical 42° C. onset of protein denaturation temperature in biological tissue with nonzero perfusion assumed in simulations. Each catheter may have a slightly different ablation transducer response to electrical power delivery and may be calibrated using acoustic measurements to identify its specific relationship of electrical power to total acoustic power. Based on the relationship of ablation depth to sets of acoustic power and time and the calibration of electrical power to acoustic power of each catheter, a dosimetry table unique to each catheter may be created that matches desired depth to a set of ablation time and electrical power.

[0249] An example of a dosimetry table-processing algorithm is shown in FIGS. 24Ci, 24Cii, 24Ciii and 24Civ. The algorithm assumes polynomial dependence of lesion depth from applied acoustic energy. The reference contours derived from equation (4) of different lesion depths in acoustic power-ablation time space are shown on the panel 575 of the FIG. 24Ci. The panels on the right include the total acoustic power measurements of a catheter 576 (FIG. 24Cii), deduced control power index and ablation times 577 (FIG. 24Ciii), and depth residual for target depth 578 (FIG. 24Civ). An empirically derived ablation trajectory in acoustic power—time space is shown by line 579. A set of discrete, catheter-specific, power and time values are shown by white diamonds 580. The discrete set of acoustic powers and times arises from a limited ability of a generator system to control electric power and ablation time. While resolution in ablation time is limited by one-second interval, the discretization of the acoustic power depends on catheter specific acoustic power performance and ability of the generator to control electrical energy to 1 dB before amplification. The algorithm is concerned with finding a closest match to desired depth amongst catheter specific, generator discretized power and time values that fit an optimal acoustic power-time trajectory. The optimal trajectory is defined as parabola with an origin at point A and tangent at point B, where point A corresponds to the lowest acoustic power

above 2 watts at 3 seconds, and point B corresponds to the highest acoustic power below 6 watts at 25 seconds. The algorithm utilizes two inputs: first, experimentally and theoretically deduced generic lesion depth dependence on acoustic energy, second, catheter specific, acoustic power dependence on generator system control index. The algorithm finds an optimal generator power index and time pairs for each desired depth that fit a chosen ablation trajectory by minimizing the function F:

$$F = \sqrt{\alpha \delta P^2 + \beta \delta t^2 + \gamma \delta d^2} \quad (5)$$

[0250] Where δP and δt are acoustic power and time deviation from optimal trajectory, and δd is deviation from optimal depth, $\alpha=4$, $\beta=1$, $\gamma=1$ are constants.

[0251] An example of a dosimetry table for a specific catheter is shown in FIG. 25. The first column of the dosimetry table constitutes a target lesion depth, the second column lists a respective electric power control index translated by generator system software in electrical power delivered to a transducer, the third column is a set of respective ablation times (duration). Additional columns list auxiliary information for verification and quality control purposes. The unique ablation dosimetry table may be programmed in a memory storage component such as an EEPROM in the specific catheter. In use when a specific catheter is electrically connected to an ablation console a computerized algorithm in the console reads the ablation depth table unique to that catheter from the memory storage component and when ablation depth is selected either automatically or manually, the algorithm selects the corresponding power—ablation time settings and deliver energy to the catheter using said settings to create the desired ablation depth.

Increasing Ablation Size

[0252] Ablation width is typically tied to ablation depth. Controllably creating a wider ablation may result in creating a deeper ablation. Ablation energy delivered from a catheter positioned in a vein (e.g., jugular vein) and aimed at a carotid septum may have a depth dimension that is oriented from a lateral to medial boundary of a carotid septum. The depth of an ablation may be optimized to cover the distance between these boundaries and it may be desired to avoid ablating beyond the medial boundary to reduce a risk of ablating an important non-target structure. With an optimized ablation depth the width may only cover a fraction of a carotid septum width depending on the anatomy of the patient. It may be desired to ablate a larger percentage of a carotid septum to increase efficacy. Ablation size (e.g., width or height) may be increased without increasing ablation depth by moving the ablation transducer and optionally the imaging transducer along with the ablation transducer. For example, motion of an ablation transducer may be accomplished by side-to-side deflection of the distal region of an ablation catheter, rotating the catheter or transducer within a catheter, or translational motion of a catheter or transducer along a length of a vessel. Motion may be performed to create multiple independent ablations or during energy delivery to spread a resulting ablation over a greater volume. Motion may be performed while imaging wherein a user may identify boundaries of a desired target zone or an ablation may be computer controlled by detecting target zone boundaries and applying ablation energy only within the boundaries. Boundaries may include for example ana-

tomical structures such as boundaries of a carotid septum. Motion of a transducer in a catheter may be accomplished manually by a user or automatically by a servomotor connected to a rotatable transducer mount that is computer controlled with a desired speed and distance and may comprise a feedback signal such as edge detection to identify a target zone. An alternative way to increase ablation size may be to direct ablation energy through a lens to diffuse or diffract energy. A lens may be inflatable with a liquid such as water or saline to adjust a desired diffusion or diffraction. Another alternative for creating wider ablations may include delivering ultrasound ablation energy from a transducer having a convex curved surface. A user may choose a catheter having a suitable curved transducer for a desired ablation width depending on a patient's anatomy. Alternatively, a catheter may have a convex curved transducer and a shield with an aperture that is adjustable to customize ablation width.

Air Bubble Elimination

[0253] The embodiments described herein that contain an echolucent chamber with flowing coolant may be adapted to reduce or eliminate air bubbles in the coolant. Air bubbles can inadvertently become included in the supply of liquid coolant (e.g., saline or water). Through surface tension, air bubbles may stay trapped in an echolucent chamber or form during energy delivery near or on an ultrasound transducer. This may negatively affect ablation or imaging performance. In the manufacture of a catheter a solution (e.g., isopropyl alcohol) carrying a surfactant may be circulated through the coolant delivery pathway and echolucent chamber, the solution may be drained and the catheter left to dry. The surfactant may be retained on the fluid-contact surfaces making all surfaces wettable, i.e., having a reduced surface tension that facilitates the removal of air bubbles.

Contrast Enhanced Ultrasound Imaging to View a Carotid Body

[0254] Any of the methods of use herein may comprise ultrasound contrast enhanced imaging, which may improve the ability to image a carotid body. An ultrasound contrast, such as commercially available SonoVue, may contain microbubbles. Differential image analysis may be performed by taking an image of the target area using an ultrasound imaging transducer (e.g., on an imaging catheter or an external ultrasound transducer) before and after injecting ultrasound contrast and comparing the images to highlight contrast from the non-contrasted tissue. The contrast may be injected into the patient's vascular system by injecting through the sheath, which may have a gasket seal on the proximal end to seal around the ablation catheter, an injection port such as a luer lock with a stopcock valve through which contrast or other injectant may be injected into the sheath's lumen in the space around the ablation catheter to be deposited out the distal end of the sheath. Areas containing the contrast typically would be areas with blood flow, including a carotid body. If a precise location of a carotid body can be identified with imaging technology such as contrast enhanced ultrasound imaging, CT or MRI, then a target ablation area may be narrowed to the carotid body. If a precise location of a carotid body is not identified a target ablation area may include a larger zone such as an intercarotid septum.

Ablation Transducer Backing

[0255] An ablation catheter may comprise an ablation transducer acoustic insulator or backing component. An ablation transducer may transmit ultrasound waves in multiple directions. For example, a plate shaped transducer whether it is substantially flat or curved may transmit ultrasound energy from both faces of the transducer. The backing component may be used to shield transmission of ablation energy so ablation energy is only directed from one face of the ablation transducer and may further serve to reduce acoustic losses.

[0256] A backing may be acoustically absorptive or reflective. A backing element may be a component containing a thin layer of gas such as air or carbon dioxide having a thickness of at least about 1 mm. The acoustic insulator may be a dense material such as stainless steel, for example having a thickness of at least about 0.006" (e.g., about 0.008").

[0257] An embodiment of an acoustic insulator containing gas comprises microspheres of air that are embedded in a substrate such as epoxy. An acoustic insulator made from air-filled microspheres embedded in epoxy may have less of a mechanical coupling effect when a transducer is placed in contact with the acoustic insulator compared to an acoustic insulator made from brass or stainless steel. In other words the vibration of the transducer may be dampened significantly less when a transducer is placed in contact with a microsphere insulator than when it is placed in contact with a dense, rigid insulator such as stainless steel or brass. Thus an air-filled microsphere acoustic insulator may be more suitable in an embodiment where a transducer is positioned in contact with the acoustic insulator. Such a design may have benefits such as ease of manufacturing, less fragile transducer, smaller catheter diameter, or more space for coolant flow in front of the transducer. A combination of microspheres having a variety of diameters may increase volume of air in an insulator. For example smaller microspheres may occupy space between larger microspheres. An acoustic insulator may have a thickness in a range of about 200 to 300 microns (e.g., about 250 microns) and may contain a combination of microspheres having diameters in a range of about 15 to 25 microns (e.g., about 20 microns) and microspheres having diameters in a range of about 180 to 210 microns (e.g., about 200 microns), for example.

Fiducial Marker to Create an Aiming Artifact

[0258] For embodiments described herein comprising one or more imaging transducers an fiducial marker may be positioned in the ablation catheter to interact with the imaging ultrasound waves to provide a distinguishable aiming artifact on the ultrasound-based video that identifies a relative position to the direction of delivery of ablation energy. This may be particularly useful for ablation catheters configured to accept a separate imaging catheter since the rotational positioning of the imaging catheter within the ablation catheter may be variable. A fiducial marker may have acoustic properties that are significantly different than the surrounding tissue for example so echoes are greater (hyperechoic) or less (hypoechoic) than the surrounding tissue. The material or surface of the fiducial marker may be highly reflective or highly absorptive of sound waves relative to surrounding tissue being imaged. A fiducial marker may have a more consistent echo compared to surrounding

tissue being imaged. A fiducial marker may be positioned to indicate on an ultrasound-based video the opposite direction of delivery of ablation energy. In this configuration the image of the aiming artifact (e.g., a shadow) will not interfere with the image of the target region and surrounding tissues. The image of the aiming artifact on an ultrasound-based video may be a distinguishable shape such as a wedge or line that is black or white radiating from the center of the ultrasound-based video in one direction and a user may understand that the ablation energy is aimed in an opposite direction.

[0259] Other relative directions or arrangements of fiducial markers may be envisioned. For example, two fiducial markers may be positioned on either side of an ablation transducer to indicate that ablation energy is delivered between two resulting aiming artifacts. Alternatively, two thin fiducial markers may be positioned close to one another to create an image resembling two bright stripes bordering a narrow stripe, which may be a more precise and detectable aiming artifact. Alternatively a fiducial marker may be placed at other positions around a circumference of a catheter as long as its relative position to a direction of aim of ablative energy is understood.

[0260] A fiducial marker may comprise a material that interacts with imaging ultrasound waves to absorb or reflect ultrasound waves in a distinguishable manner compared to typical tissue in a target region. For example, the material may be a dense material such as stainless steel or an air-filled component that inhibits transmission of ultrasound. In some embodiments, an fiducial marker may be a component that also acts as a backing material for an ablation transducer that also inhibits transmission of ablation energy. In other embodiments a fiducial marker may be a separate component or may provide other functions such as structural support for a distal end component, a guide wire lumen, or an echolucent shell support.

[0261] An embodiment of a fiducial marker comprises a stainless steel hypotube with a lumen containing air or air-filled microspheres held in epoxy. The hypotube may be sealed at both ends with an adhesive to contain the air or microspheres. The hypotube may have an outer diameter of about 0.028" to 0.038" for example.

[0262] Another embodiment of fiducial marker comprises a wire such as a round wire (e.g., having a diameter of about 0.028" to 0.038"), or a flat ribbon wire (e.g., having a profile of about 0.005" by 0.030"). The wire may be stainless steel. Optionally, the wire may be surrounded by a component that further interacts with ultrasound imaging waves, for example a metal coil may be wrapped around the wire or the wire may be coated in an epoxy containing microspheres of air.

[0263] A fiducial marker may have increased echogenicity to increase its distinctive characteristics compared to surrounding tissue. For example, a fiducial marker may comprise a rough surface or a linear pattern of grooves or surface with a texture that enhances reflectivity of ultrasound waves. This may be particularly helpful when an imaging transducer is not parallel to the fiducial marker. Some ultrasound imaging catheters comprise transducers that are positioned at a slight angle to axis of the catheter. Although the angle may be small it may cause waves to reflect off of the fiducial marker at an angle of incidence that reduces the ability of the transducer to capture echoes.

[0264] A fiducial marker may comprise a piezoelectric element that vibrates when high frequency current is applied emitting an acoustic signal that may be detected by the imaging transducer to provide a robust image of the fiducial marker.

Image Augmentation

[0265] A system for imaging a target region and ablating tissue in the target region may provide a digital video, or ultrasound-based video, created from ultrasound signals transmitted from an ultrasound imaging transducer, reflected off of tissues, and received by the imaging transducer. An example of a frame of an ultrasound-based video created with an IVUS catheter placed in a jugular vein in proximity to a carotid bifurcation is shown in FIG. 30.

[0266] An ultrasound-based video may be further augmented with visual aids, animations, or messages to provide information to a user that may assist understanding of the ultrasound-based video, planning or conducting a carotid body ablation procedure.

[0267] An embodiment of a system for imaging and ablation of a carotid body having image augmentation may comprise a catheter with an ultrasound imaging transducer and an ablation means, an ablation console, an ultrasound imaging console with a means for transmitting and receiving signals to and from the imaging transducer and a computer executed algorithm that creates an ultrasound-based video from signals received from the imaging transducer, an image augmentation unit that processes the ultrasound-based video with a computer algorithm that creates an augmented image, and a monitor to display the augmented image. A schematic diagram of a system is shown in FIG. 27. The image augmentation unit hardware may comprise an image or frame grabber, RAM, a CPU, storage such as a hard drive, and a graphics card. The imaging console may (a) send an ultrasound imaging signal to the imaging transducer 435, (b) receive an echo signal from the transducer, and (c) send an ultrasound-based video signal to the image augmentation unit. The ablation console may (d) send ablation energy to the ablation element 436 (e.g., ultrasound ablation transducer), (e) receive feedback from a sensor in the catheter such as a temperature sensor, (f) send information (e.g., ablation status, energy delivery parameters, user interface controls, information to be displayed on the monitor) to the image augmentation unit, and (g) receive information (e.g., to control ablation status, to control energy delivery parameters) from the image augmentation unit. The image augmentation unit may also (h) send a video to a monitor.

[0268] The catheter may be an embodiment described herein of an ablation catheter configured to accommodate an ultrasound imaging catheter or with an integrated imaging transducer(s) and may further comprise an aiming artifact to identify a direction of delivery of ablation energy on an ultrasound-based video. An ablation means may comprise an ultrasound ablation transducer or other ablation energy delivery device such as a needle that penetrates a vessel wall to deliver RF energy or a chemical agent to an ablation target tissue. The system may further comprise an ablation energy console suitable to the ablation means such as an ultrasound generator or RF generator.

[0269] The imaging transducer, or transducer, may be for example a piezoelectric or capacitive transducer positioned in or on a distal region of the ablation catheter near an ablation element (e.g., ultrasound ablation transducer, RF

needle, needle for injecting a chemical agent, RF electrode, laser emitter). The imaging transducer may transmit acoustic waves to the space around the distal region of the catheter and receive acoustic waves echoed off of tissue in the space.

[0270] An ultrasound imaging console may generate an electrical signal and control delivery of the signal to the imaging transducer to be converted to ultrasound waves. Echoes received by the imaging transducer may be converted to an electrical signal, which is transmitted back to the imaging console. Some embodiments may use separate transmitter and receiver components or consoles. In some embodiments an imaging transducer may be positioned on an ultrasound imaging catheter (e.g., Visions® 0.035 catheter by Volcano Corporation, or UltraICE™ catheter by Boston Scientific) and an ultrasound imaging console may be a system compatible with the imaging catheter. An imaging catheter and compatible imaging console may be provided separately from the system, which may be configured to accommodate the imaging catheter and imaging console. In another embodiment an imaging transducer may be integrated in an ablation catheter, an imaging console may be separate from an ablation energy console or may be integrated into a single unit, and both the imaging transducer and imaging console may be provided as part of the system.

[0271] The electrical signals generated by the echoes impacting the transducer and transmitted back to an imaging console may be used to create an image or video (i.e., ultrasound-based video) that may be displayed on a monitor. For example the signals may be processed by a computer-executed algorithm and output to a monitor or a video output port on the ultrasound imaging console.

[0272] Image grabber hardware, used to capture images or video, is known in the art and may consist of a hardware interface that captures single frames of video, converts the analogue values to digital and feeds the result into a computer. The image grabber may be connected to the video output port on the ultrasound imaging console, for example, and may send a digital interpretation of the video to an image augmentation computer, which may be incorporated into the ultrasound ablation console or be a separate unit.

[0273] The image augmentation computer may run an algorithm to augment the video. The algorithm may process each video frame in real time tracking the orientation of the ablation catheter using a fiducial marker or aiming artifact in the images. The algorithm may identify an aiming artifact by looking for any distinct marker that does not change shape when the orientation changes. Inputs to the algorithm may be provided by the ultrasound-based video, the ablation console (e.g., console status, energy delivery status, depth parameters), or a user interface (e.g., identification of anatomical features, settings, zoom, pan, contrast, features to display). Outputs may be to a monitor (e.g., an augmented image, an original ultrasound-based video, an augmented image overlaid on an ultrasound-based video), or to an ablation console (e.g., signal to control energy delivery, signal to control energy delivery parameters such as power and time).

[0274] In addition to the captured video, a user may control inputs to the algorithm. For example, a user may select a desired ablation depth or identify a part of the anatomy such as an internal carotid artery or external carotid artery. User inputs may be controlled by a user interface (e.g., knobs, dials, touchscreen, mouse, voice control) that may be on the unit containing the image augmentation

computer (e.g., the ablation console). Before delivering ablation energy, a user may adjust ablation depth on the ablation console, for example if the overlaid image of an estimated ablation appears to be too long and extend beyond the borders of a carotid septum, or too short and not fill a carotid septum adequately, and the overlaid image of an estimated ablation may reflect the adjusted depth. In an embodiment wherein the ablation element is an ultrasound ablation transducer ablation depth may be controlled by automatically adjusting parameters such as power and time for a given frequency.

[0275] The image augmentation algorithm may output a signal to a monitor. For example, if the algorithm is on a computer physically contained in an ablation console the output may be to an output port (e.g., a VGA, SVIDEO, DVI, HDMI port) or cable connected to an external monitor or to a monitor on the ablation console. An external monitor may be supplied with the system or separately as part of a catheter lab's equipment. The monitor may display other information in addition to the ultrasound-based video with augmented image overlay such as fluoroscopy or X-ray, patient information, or physiological parameters.

[0276] Black and white versions of embodiments of augmented video frames are shown in FIGS. 28 to 31. The algorithm may identify an expected image of the imaging catheter which may be generally a dark circle 440 in the center of the image, and an aiming artifact which may be generally a distinctive (e.g., dark or white) wedge 441 radiating from the center of the image. An aiming artifact, for example produced by a fiducial marker or a synchronized aiming emission, may be particularly useful in embodiments wherein a separate imaging catheter is inserted into an imaging catheter lumen of an ablation catheter. Alternatively, for embodiments wherein imaging transducers are integrated with an ablation catheter an aiming artifact may be produced by a fiducial marker, a synchronized aiming emission, or by omitting an imaging transducer in a direction relative to the direction of aim of ablation energy, or instead of an aiming artifact the direction of aim may be programmed into the imaging algorithm and displayed on an ultrasound-based video. A user may deliver the catheter containing the imaging transducer through vasculature to a region proximate a carotid bifurcation using fluoroscopic imaging guidance. In the example shown in FIGS. 28 to 31, a catheter is delivered through a venous approach to a region near a carotid bifurcation. The algorithm may be programmed to expect anatomy based on a catheter delivery approach. In the example shown the algorithm may expect that the dark circular shape 442 around the imaging catheter in the center of the image is an internal jugular vein 12 and two dark circles 443 and 444 in the region within a size range of about 3 to 8 mm may be carotid arteries. If an imaging system is capable of imaging other anatomical features such as a carotid body or carotid nerves or non-target nerves, they may be identified as well. As shown, the augmented image may comprise an overlay of images on the ultrasound-based video such as an outline of a carotid artery (e.g., common carotid artery, internal carotid artery 445, external carotid artery 446), an outline of the ablation catheter 447, an arrow 448 indicating a direction of delivery of ablation energy or a direction that the ablation element is facing or will deliver ablation energy. In the embodiment shown the ablation element may be an ultrasound ablation transducer and the augmented image comprises lines 449

indicating estimated lesion width projected in the direction of delivery of ablation energy. The augmented image also comprises an outline of an estimated ablation 450 in a location where it is expected to be created. The estimated ablation outline may be distinguishable 451 (e.g., red, shown in a dashed outline in FIG. 31) if it is positioned in an unsuitable region, for example if it is not within the borders of an intercarotid septum, if it is contacting or too close to a carotid artery, or if it is at a position where an ablation was previously made. The estimated ablation outline may be distinguishable (e.g., green, shown as a dash-dot outline 450 in FIG. 28) if it is in a position ideal for creating an ablation, for example between carotid arteries in an intercarotid septum.

[0277] To confirm identification of the internal and external carotid arteries the user may be asked to slowly slide the catheter out and in by a few centimeters, which may create an video of the two carotid arteries converging to a common carotid artery as the catheter is pulled out and diverging to internal and external carotid arteries as the catheter is pushed in.

[0278] As shown in FIG. 30 when ablation energy is being delivered the augmented image may display an animation to indicate energy delivery for example a pulsing, colored light (shown in FIG. 30 as lines 452). An animation may be displayed that indicates progression of time through the duration of an ablation, for example growing color bar (shown in FIG. 30 as lines 453) can fill in the estimated ablation outline wherein an empty outline indicates time=0 s and a full outline indicates a complete duration.

[0279] After an ablation has been created an image of the ablation 453 with respect to the carotid arteries may be displayed, for example with distinct color such as white as shown in FIG. 33, which displays a completed ablation and a second ablation under way.

[0280] The information computed by the image augmentation algorithm could be fed back to the energy delivery console. If there is inadvertent movement during delivery of ablation energy the augmented image algorithm may send a signal to the ablation console to pause or discontinue delivery of ablation energy and the augmented image may display a partially filled ablation outline in a color such as red to indicate a suitable time may not have been achieved to create a desired ablation depth and a user may choose to perform another ablation in the same location.

[0281] If the catheter is pushed forward or pulled back the image augmentation algorithm may calculate translational movement using the change in distance between the internal and external carotid arteries.

[0282] Information from other imaging sources such as fluoroscopy, MRI, CT, or a second ultrasound imaging transducer may be input into the image augmentation algorithm and may be used to create an image of location of a carotid body or nerves, to calculate bifurcation angle, to create a 3D image, or to calculate height of an ultrasound imaging plane above a carotid bifurcation.

[0283] Another fiducial may be used to identify distance from a carotid bifurcation (e.g. distance in a superior direction to a carotid bifurcation). For example a fiducial marker may be a wire that is slidable within a lumen of the catheter. The wire fiducial may have a distinguishable echogenic marking that may be aligned with a carotid bifurcation. The wire fiducial may be held in place as the catheter is advanced. The wire fiducial may have another distinguish-

ing marking at a predetermined distance from the first marking (e.g., about 6 mm from the first marking). When the catheter is advanced until the second marking is seen it may be understood that the imaging plane is the predetermined distance (e.g., 6 mm) from the bifurcation. The wire fiducial may have multiple markings to indicate increments (e.g., every 2 mm). The wire fiducial may also have radiopaque markings that can be visualized on fluoroscopy.

[0284] The algorithm may control rotation of the image so the augmented image may be displayed for example, with the direction of aim always up.

[0285] An image augmentation algorithm may use a known dimension such as diameter of the catheter or width of an aiming artifact as a scale and calculate distances between anatomical features for example, relative positions of an internal jugular vein, a carotid septum, an internal carotid artery, an external carotid artery, carotid septum boundaries, artery diameters, change in artery diameters, change in relative position of anatomical features, size and relative position of an estimated ablation or created ablation. Calculated distances may be displayed on an augmented image overlay, for example, as a list or with labels. The algorithm may provide user instructions or suggestions based on calculated distances, for example, how much to torque or deflect the catheter to manipulate the vessel (e.g., jugular vein) containing the catheter, how much and which direction to torque the catheter to adjust aim of the ablation element, adjustments to ablation depth or parameters affecting ablation depth, how to move the catheter in or out of the vessel to achieve a suitable position.

[0286] An image augmentation algorithm may input information to the ablation console. For example, measurements and relative positions calculated by the image augmentation algorithm may be used to automatically adjust parameters (e.g., power and time) to control ablation depth so the estimated ablation size is optimally within and filling space between medial and lateral borders of a carotid septum. The image augmentation algorithm may detect significant movement during ablation that may send a signal to the ablation console to pause or terminate delivery of ablation energy. Ablation may be performed in a sweeping mode where ablation energy is delivered while moving the aim, for example rotating an ultrasound ablation transducer to sweep across a carotid septum from one carotid artery to another. An image augmentation algorithm may indicate to a user when to move or how fast to move the aim and may signal the ablation console to pause energy delivery when a significant amount of energy is delivered to a position then continue to deliver energy when the image augmentation algorithm detects movement to a suitable position. Alternatively, motion of ablation aiming may be controlled by a mechanism such as a servomotor controlled by input from the image augmentation algorithm based on calculated measurements and relative positions.

Movement Detection

[0287] Ablative energy, particularly ultrasound ablation energy, may be delivered for a duration of less than about 30 s (e.g. less than about 25 s, less than about 20 s, between about 7 to 23 s). While ablative energy is being delivered the direction of aim of ablative energy may move inadvertently from a desired target direction. This may cause a risk of creating an ineffective ablation in the desired target tissue, or

injuring a non-target tissue. A number of methods of mitigating these risks are disclosed.

[0288] Movement of the directed ablation energy from the target tissue may be caused for example by patient movement (e.g., sudden or slow movement, caused by moving the head, coughing, sneezing, flinching), or movement of the catheter or a component external to the patient connected to the catheter.

[0289] Detection of potential movement of the directed ablation energy from the target tissue may comprise the following: monitoring movement of the patient's body or head manually by a user or automatically with image tracking or sensors such as an accelerometer; an imaging algorithm or image augmentation algorithm may be programmed to identify movement that is significant to increase risk; a sensor such as an accelerometer or multiple accelerometers may be positioned in an ablation catheter such as those disclosed herein; a 3D orientation and tracking system for example using a magnetic or electric field to detect a magnetic coil or electrode positioned in an ablation catheter may be used to track the device within a patient's body.

[0290] Mitigation of a risk of movement may involve the following methods: a user may manually disengage energy delivery if movement is detected; a user may be required to hold an actuator in an on position to deliver energy and may react quickly to movement by releasing the actuator; automatic patient movement detection may input to the energy delivery console to cease or adjust energy delivery; an imaging or image augmentation algorithm detecting significant movement may send a signal to the energy delivery console causing it to cease or adjust energy delivery.

[0291] Upon stopping or adjusting energy delivery, an energy delivery console may display a message to a user that the delivery of energy was cut short due to potential movement risk. The message may further display how much of the procedure was completed.

Ultrasound Imaging Guided Interstitial Ablation Needle

[0292] Many embodiments disclosed herein comprise high-energy ultrasound as an ablative energy. Alternative embodiments of an endovascular catheter with imaging capabilities may comprise other forms of ablative energy to ablate target tissue (e.g., tissue in a carotid septum) near a vessel (e.g., jugular vein). An ultrasound imaging guided needle ablation catheter may combine an endovascular ultrasound imaging transducer for detecting a target and directing an ablative needle toward the target. The ablative needle may deliver an ablative agent or other ablative energy such as radiofrequency or cooled radiofrequency. As shown in FIG. 32, an ultrasound imaging guided interstitial ablation needle catheter 460 may comprise an ultrasound imaging transducer and a deployable needle. The imaging transducer 461 may be on a separate catheter (e.g., IVUS catheter) that is advanced through a lumen 462 in the ablation catheter to a distal region of the ablation catheter. The imaging transducer may be positioned in an optional echolucent chamber 463 that contains an fiducial marker for aiming 464 that reflects or absorbs ultrasound waves to create a distinguishable artifact on an ultrasound-based video that represents a relative direction that the deployable needle 465 will be advanced. The deployable needle may have a sharp tip 466 to advance through a vessel wall (e.g., jugular vein 12). As shown, a blunt tipped probe 467 may be advanced out of the sharp tipped needle to pass through target tissue. A blunt

tipped probe may pass through tissue such as fat in the target zone and reduce a risk of puncturing an artery (e.g., carotid artery) or injuring a non-target nerve. The probe 467 may be configured to deliver ablation energy. For example, it may comprise an RF electrode 468, a cooled RF electrode, or a lumen to deliver an ablative agent. The probe may contain a sensor 469 such as a temperature sensor (e.g., thermocouple) to monitor or control energy delivery. The deployable sharp needle or probe may have an echogenic coating to improve ultrasound imaging. The catheter may be deflectable or be delivered through a deflectable sheath to assist in positioning or manipulation of a vein to obtain a suitable ablation position. Multiple needles may be deployed for example to create a larger ablation by delivering radiofrequency in a bipolar configuration. A carotid body stimulation agent (e.g., adenosine) may be delivered through injection lumen 470 or a deployable needle or probe to a target zone before and after ablation to confirm if a carotid body has been deactivated.

[0293] As shown in FIG. 33 an alternative embodiment of an ultrasound imaging guided needle ablation catheter 471 may comprise imaging transducer(s) 472 integrated with the ablation catheter. In comparison to the embodiment shown in FIG. 32 this embodiment may have a narrower diameter (e.g. in a range of about 8 to 10 FR, about 9 FR) and absence of an Imaging catheter lumen provides more space for a needle lumen 473. An integrated set of imaging transducers 472 may allow a relative direction of needle deployment to be programmed into the ultrasound-based video generation software so the direction of needle deployment can be indicated on an ultrasound-based video. Alternatively the integrated set of imaging transducer(s) may comprise a gap in transducer spacing or a fiducial marker to create a distinguishable image that identifies a relative direction with respect to the needle deployment direction.

[0294] In embodiments wherein a chemical ablation agent is delivered to the target tissue the chemical agent may be delivered in a medium such as a gel with a low viscosity so it remains local to the target tissue.

Ablation Catheters with Integrated Imaging Transducer(s)

[0295] FIGS. 34A, 34B, 34C, 35, and 36 show embodiments of ablation catheters comprising integrated imaging transducers positioned distal to an ablation transducer. These embodiments may be delivered through a sheath such as a steerable sheath shown in FIGS. 25A to 25C, into a vein (e.g., internal jugular vein) in proximity to a target carotid septum. The steerable sheath may be used to manipulate the position of the vein with respect to the target carotid septum or facilitate positioning and aiming the ablation transducer. These embodiments may have a diameter of about 8.5 FR to 9 FR.

[0296] FIG. 34A shows a distal assembly 480 of an ultrasound catheter comprising an ablation transducer 481 mounted to a backing material 482 (e.g., such as those described herein), which is mounted to an ablation transducer support 483. The ablation transducer support is machined to comprise a cavity 484, which in combination with a thin polymer shell 485 (e.g., PET of about 0.0008" thick, or nylon of about 0.0003" thick) defines an echolucent chamber. The polymer shell surrounds the echolucent chamber and is sealed to the ablation transducer support to hermetically seal the chamber. Coolant may be delivered through a coolant delivery lumen in the catheter shaft to the echolucent chamber where it exits the lumen from a coolant

delivery port 487. The catheter is configured to pass coolant over the ablation transducer to maintain suitable transducer temperature so it doesn't overheat. Overheating may damage the transducer, the catheter, or the vessel tissue or cause blood to clot. The coolant may exit the chamber via a coolant exit port 486, which is in fluid communication with a fluid exit lumen 488 that passes the coolant along the catheter shaft releasing it outside the patient's body. The catheter may optionally be configured to be delivered over a guidewire 489 by comprising a guidewire lumen 490 along the shaft and ablation transducer support (see FIGS. 34B and 34C) or with a rapid exchange guidewire port at a distal region of a catheter (e.g., a rapid exchange guidewire port may be positioned distal to the ultrasound transducer(s), not shown). The catheter comprises a series of imaging transducers 491. As shown in cross section B-B of FIG. 34C the imaging transducers may be positioned around the circumference of the catheter except for a location 492 on the circumference opposite the direction of aim 493 of the ablation transducer. An ultrasound-based video created from the series of imaging transducers may show an artifact from the absent transducer that provides an indication of the direction of aim of the ablation transducer. Alternatively, imaging transducers may be positioned around the entire circumference and a segment of the array may be disabled to provide an image artifact that provides an indication of the direction of aim of the ablation transducer. Alternatively, imaging transducers may be positioned around the entire circumference of the catheter and an imaging artifact that blocks imaging ultrasound may be positioned, for example in the opposite direction as the direction of aim of the ablation transducer, to identify the direction of aim of the ablation transducer on an ultrasound-based video. Alternatively, the direction of aim of the ablation transducer with respect to the series of imaging transducers may be programmed into the software that generates an ultrasound-based video so the direction of aim may be indicated on the ultrasound-based video.

[0297] The embodiment shown in FIG. 35 comprises a fluid-filled balloon 495 surrounding an ablation transducer 496 to contain flowing coolant such as sterile water or saline. The balloon may be delivered in a sheath in an undeployed state and when advanced out of the sheath coolant may be delivered through a coolant delivery lumen to a cavity in the balloon to increase pressure and deploy the balloon to a deployed state as shown having increased diameter. The deployed state may allow greater coolant volume around the ablation transducer or may allow the ablation transducer to be larger than the transducer of the embodiment shown in FIG. 34.

[0298] An embodiment shown in FIG. 36 comprises a weeping polymer shell 500 that has tiny perforations 501 that allow coolant (e.g., saline) 502 to weep from the chamber. A weeping shell may impede blood from warming or clotting to the catheter where therapeutic ultrasound energy is passed.

[0299] The embodiments shown in FIGS. 35 and 36 may optionally comprise other features described with FIGS. 34A, 34B, and 34C such as a guidewire lumen and a means for indicating a direction of aim of the ablation transducer.

[0300] An embodiment shown in FIG. 38 comprises an ablation transducer 585 positioned to emit ablative ultrasound energy approximately laterally from a catheter. Distal to the ablation transducer is a rotating imaging transducer

587 that is mounted to a drive shaft **588**, which may pass through the catheter shaft to a proximal end of the catheter where it is rotated by a motor. A fiducial marker **589** may be positioned in the imaging transducer's field of view providing a relative direction with respect to the direction of aim **586** of the ablation transducer. The rotating imaging transducer may produce an ultrasound-based image or video of an approximate plane transecting the catheter distal to the ablation transducer (e.g., about 2 mm distal, between about 1 mm and 3 mm distal, less than about 4 mm distal). The fiducial marker may be a band of stainless steel, or a component that has multiple functions such as a guidewire, or other embodiment of a fiducial marker as described herein.

[0301] Alternative embodiments may have one or more imaging transducers positioned proximal to the ablation transducer, or both proximal to and distal to the ablation transducer, such as in FIGS. **6A**, **6B**, **7A**, **7B**, **7C**, **8A**, **8B**, **8C**, and **8D** herein. These figures show catheters having imaging transducers **125**, **133**, **132**, **140**, **141** and **142** that generate wedge shaped images that represent a portion of a transection of tissue around the catheter. In other embodiments imaging transducers may be arranged as multiple transducers or a rotating transducer (for example see embodiments shown in FIGS. **34A**, **34B**, **34C**, **35**, **36**, **38**, **45A-E**) to generate an image that represent a complete transection or a larger portion (e.g., greater than 75%, greater than 85%) of a transection of tissue around the catheter. Such arrangements of multiple transducers or rotating transducers may be positioned distal to, proximal to, or both distal and proximal to an ablation transducer on a catheter. An exemplary method of use of a catheter comprising an imaging transducer or set of imaging transducers proximal to an ablation transducer may include moving the catheter until the imaging transducer(s) is positioned relative to a target ablation site (e.g., a carotid septum) to provide an image of the target site or anatomical landmarks associated with the target site (e.g., internal carotid artery, external carotid artery, carotid bifurcation), and adjusting a position of the catheter to move the imaging transducer(s) to a position proximal to the target ablation site in order to position the ablation transducer in alignment with the target ablation site. For example, an imaging transducer or plurality of transducers may generate an image of a plane of tissue that is about 1 to 15 mm (e.g., about 5 mm, about 10 mm, about 3 to 12 mm) from the center of the transmitting face of the ablation transducer. The catheter may be moved until an image is obtained of an anatomical landmark such as a carina of a carotid bifurcation, which may indicate that the ablation transducer is positioned in a desired location to deliver ablation energy a known distance (e.g., about 1 to 15 mm, about 5 mm, about 10 mm, about 3 to 12 mm) distal to the image, which may furthermore be in alignment with target tissue to ablate the target tissue safely and effectively. Other exemplary methods of use described above with respect to FIGS. **6A-8D** may also be performed. The catheter may further be configured to provide an indication of direction of aim of the ablation transducer, such as those described herein (e.g., a fiducial marker that provides an indication of a relative direction of aim of the ablation transducer on an ultrasound image generated by the imaging transducer(s), or the set of imaging transducers may be configured to create an artifact that coincides with the direction of aim of the ablation transducer).

[0302] A distal end **700** of an embodiment of an ablation catheter comprising an integrated imaging transducer array **702** positioned proximal to the ablation transducer **703** is shown in FIGS. **45A**, **45B**, **45C**, **45D**, and **45E**. Any of the suitable disclosure above related to the embodiment in FIGS. **34A-34C**, including relevant methods of use, can similarly be incorporated into the embodiment shown in FIGS. **45A-45E**.

[0303] Methods of manufacturing imaging transducers or arrays are known in the art. For example, imaging transducer array **702** may be manufactured according to methods disclosed in U.S. Pat. No. 6,776,763 B2, assigned to Volcano Therapeutic Inc., and which is incorporated by reference herein.

[0304] As shown, in this embodiment the ablation catheter comprises a guidewire lumen **718**, which is configured such that the catheter can be delivered over a guidewire **705**. A guidewire may facilitate delivery of the catheter in particular to vessels that are small in diameter or across a tight bend, such as when delivering the catheter to a tributary of a jugular vein such as a facial vein. The catheter may also be delivered through a delivery sheath **706**. FIG. **45B** shows a side view of the embodiment of FIG. **45A** and illustrates a configuration for a guide wire lumen. The catheter shaft **706** may be made from Pebax® with a durometer of about 40 D to 55 D and has a central lumen **708**. The shaft **706** is connected to an imaging array **702**, which is connected to an ablation transducer support **710**. An echolucent membrane material **711** partially defines an echolucent chamber **712** containing an ablation transducer **703**. The ablation transducer support also partially defines the echolucent chamber **712**. Distal to the ablation transducer support **710**, a radiopaque, rounded end cap **714** is connected.

[0305] A tube **715** may be disposed and extend through the shaft's central lumen **708**, through a central lumen in the imaging array, and into the proximal end of the ablation transducer support **710**, as shown in FIG. **45B**. Tube **715** can include a lumen that may carry electrical wires (not shown for clarity) that connect to the transducer and pass to the proximal end of the catheter, wires for a temperature sensor (not shown) to measure ablation transducer temperature, and a guide wire tube **716** that defines a guidewire lumen. The guidewire tube **716** may be a flexible polymer tube such as polyimide having an inner diameter (e.g., about 0.020") through which a guidewire (e.g., having a diameter of about 0.0181") may be inserted. As shown, the guide wire tube **716** passes through the tube **715** and through the ablation transducer support **710** in a channel **717** behind the ablation transducer (relative to a direction of aim of the ablation transducer), then to a central lumen **718** of the end cap **714**. This configuration in which the guidewire lumen is not co-axial with the central axis (which may also be referred to herein as longitudinal axis) of the catheter allows the ablation transducer to be positioned near or at the central axis of the catheter. By positioning the ablation transducer at or near the central axis, as opposed to closer to the periphery of the catheter, the ratio of the catheter diameter to ablation transducer width can be made smaller. For example the ablation transducer may be 2 mm wide and the catheter may be 8.5 Fr. In some embodiments the ratio of the catheter diameter to the ablation transducer width is no more than 2.5. In this embodiment the guidewire lumen is optionally not in general alignment with the guidewire lumen at locations proximal and distal to the ablation transducer.

[0306] The embodiment of an exemplary ablation catheter shown in FIGS. 45A and 45B is configured for using saline as a transducer coolant. As indicated by flow lines 719, saline may flow through the lumen of tube 715 and enter the echolucent chamber 712, then exit the catheter through the central lumen 718 of the end cap 714 into the blood stream, carrying excess heat away from the ablation transducer. Alternatively, the saline coolant may exit from the echolucent chamber through holes in the membrane 711 (not shown), which may be evenly spaced across the surface of the echolucent chamber 712 or in the distal region of the chamber. Coolant exiting through the membrane may provide thermal protection of the vessel wall. Alternatively, the saline coolant may exit through a port (not shown) in the catheter distal to the echolucent chamber but not sharing a lumen 718 with the guidewire tube 716. The ablation transducer may be electrically insulated, for example with Parylene (not shown), to prevent short-circuiting through the saline. Examples of insulated, saline compatible transducer configurations are disclosed herein.

[0307] In this embodiment the membrane 711 extends over an outer surface of the ablation transducer support at proximal and distal ends of the ablation transducer support, but in some embodiments it may extend over the support only at one end, or optionally not extend over an outer surface of the ablation transducer support. In this embodiment the membrane is arranged so that the echolucent chamber substantially conforms to an outer surface of the catheter proximal and distal to the echolucent chamber. In this embodiment membrane 711 has a configuration that generally follows the configuration of at least a portion of the outer surface of the catheter proximal and distal to the chamber. In this embodiment the membrane 711 is not adapted to expand outward as fluid is delivered into the chamber, but in other embodiments it may be adapted in such a way. By not being adapted to expand radially outward, the membrane 711 generally can be thought of having fixed configuration. In some embodiments the membrane 711 has a thickness between 0.0002" and 0.009".

[0308] The imaging array 702 may be configured to show an image artifact that identifies a relative direction of aim of the ablation beam, for example as described herein and shown in FIG. 34C. An image artifact may be created by a space in the imaging array, a disabled segment of the array (e.g., if one or more imaging transducer can be individually deactivated and activated), a fiducial marker or programmed in to software that generates an image from the array. The imaging array may be configured to present the image artifact opposite to the direction of aim of the ablation beam.

[0309] The embodiment shown in FIG. 45A may comprise radiopaque markers used to facilitate placement and orientation of the catheter relative to a target site. As shown in FIG. 45C, the imaging transducer array 702 may comprise a radiopaque marker 720 at the level associated with the imaging plane 721. For example, the imaging plane 721 and center of the radiopaque marker 720 may be a predetermined distance 724 (e.g., 6 mm, 7 mm, 8 mm, 9 mm, 10 mm, or a distance in a range of 1 to 15 mm) from the center 726 of the ablation transducer 703. The catheter 700 may be placed in a deflectable delivery sheath 722 having a radiopaque marker 723 such that the imaging array marker 720 is a distance 725 from sheath marker 723, wherein distance 724 and 725 are approximately the same (e.g., 8 mm or a distance in a range of 1 to 15 mm). In some embodiments

approximately the same means that one of distances 724 and 725 is within 10% of the other, or within 5% of the other.

[0310] The distal region 700 of the ablation catheter may comprise a sheath alignment line 701 used to position the catheter in the sheath 722 to confirm that the sheath's marker 723 is the desired distance 725 from the imaging plane marker 720. The alignment line 701 may be printed or etched on the catheter shaft or applied as a heat shrink band or may be a visually distinguishable line applied to the catheter using methods known in the art of catheter manufacture. The thickness of the alignment line 701 may be in a range of 0.1 mm to 1 mm for example. A method of positioning the catheter in the sheath may comprise inserting the catheter into the sheath before inserting them into a patient's vasculature; visually aligning the distal end of the delivery sheath 722 with the sheath alignment line 701; positioning a movable depth gauge 739 such as a spring clip on a proximal end of the catheter shaft snug against the proximal port 741 of the delivery sheath as shown in FIG. 45E; removing the ablation catheter from the delivery sheath 722 keeping the depth gauge 739 positioned on the catheter shaft. The catheter with the positioned depth gauge 739 may then be inserted into the patient's vasculature by first delivering the sheath into the vasculature then inserting the ablation catheter into the sheath until the depth gauge 739 butts against the proximal port 741 of the sheath as shown in FIG. 45E. A method of positioning this catheter and sheath relative to a target tissue and identifying ablation depth may comprise advancing the catheter 700 and sheath 722 to a first position as shown in FIG. 45C by aligning imaging marker 720 with an anatomical landmark L such as a carotid bifurcation and imaging the landmark L with the ultrasound imaging array 702. The distance 724 aligns the center of the ablation transducer 722 with the center of the target tissue T (e.g., carotid septum) when the landmark L is seen on the ultrasound image. An X-ray image may be taken to capture this first position and highlight the radiopaque markers 720 and 723. Then as shown in FIG. 45D the catheter 700 and sheath 722 may be advanced to a second position wherein the sheath's marker 723 is moved to the first position of the imaging marker 720 and aligned with the landmark L. The second position of the markers can be seen on fluoroscopy and compared to a phantom of the captured image of the first position. In this second position the imaging plane 721 is now where the ablation transducer center 726 was in position 1 and an ultrasound image may be taken of the target region including the center of the target tissue T and surrounding tissue. From this image the distance 727 between the catheter and target T can be measured and used to adjust dosimetry and control ablation depth. Then the catheter 700 and sheath 722 may be repositioned back to position 1 wherein the imaging plane 721 is aligned with the landmark L. The direction of aim of the ablation transducer may be pointed at the target T by rotating the catheter to aim the image artifact relative to the landmark. In this position the ablation beam will be aimed at the target T. Ablation depth may be entered into the ablation console to set energy delivery parameters (e.g., power and time) and ablation energy may be delivered.

[0311] As shown in FIG. 45E the components of a system used with the embodiment shown in FIG. 45A and other embodiments having an integrated imaging transducer or array of transducers and configured for open looped saline cooling may include the following: a deflectable delivery

sheath 722 (e.g., 8.5 FR compatible), the ablation catheter 700 with integrated imaging (the proximal end of the catheter including a handle 730 is shown), a saline coolant supply 731, a coolant pump 732, a coolant tube 733 that is connectable to the coolant supply 731 and a coolant input port 734 on the handle 730, a computerized ultrasound ablation console 735 that is electrically connected to an electrical connector 736 of the handle 730 via a connector cable 737 and in communication with the pump 732, an ultrasound imaging console 738 in communication with the ablation console, and a guidewire 740. The computerized ablation console 735 may optionally comprise an image augmentation algorithm such as illustrated by FIGS. 27, 28, 29, 30 and 31.

Catheters Configured to be Used without a Delivery Sheath

[0312] A delivery sheath may provide several useful functions for a transvascular ablation catheter, in particular a catheter configured for carotid body ablation from a jugular vein. For example, a delivery sheath may provide a conduit to deliver multiple devices including an ablation catheter; it may protect the ablation catheter from physical damage during insertion; it may provide deflection or torque near its distal region to facilitate manipulation of the jugular vein to position the imaging or ablation catheter relative to a target ablation site (e.g., carotid septum, carotid body, carotid bifurcation, carotid arteries); it may allow the imaging or ablation catheter to be extended or retracted or rotated relative to the deflected region of the sheath to allow for a range of configurations suitable for manipulating a shape or alignment of the carrier vein (e.g., jugular vein) or achieving an ideal positioning of its imaging or ablation transducers or elements relative to a target ablation site. For example, an optimal position of an imaging transducer(s) during a carotid body ablation procedure may be within about 5 mm (e.g., within about 3 mm, within about 2 mm, within about 1 mm) distal or proximal to a carotid septum or a carotid bifurcation or anatomical landmarks such as carotid arteries. An optimal position of an imaging transducer(s) during a carotid body ablation procedure may alternatively or additionally be within a distance of anatomical landmarks and alignment with them such that a direction of aim of an ablation transducer relative to the ultrasound image obtained may be aimed at a target ablation site while avoiding passing through non-target tissues such as carotid arteries or other vessels or tissue that could interfere with delivery of ablation energy to the target site. For example, a direction of aim of an ablation transducer may be directed through a wall of a vein containing the catheter (e.g., jugular vein), through a limited amount of interstitial tissue (e.g., less than about 5 mm, less than about 4 mm, less than about 3 mm, less than about 2 mm, less than about 1 mm), and into a target tissue volume (e.g., a carotid septum).

[0313] In some embodiments a catheter for transvenous imaging and ablation may be configured to provide functions of a delivery sheath and may thus be used without a delivery sheath. For example, the catheter may be configured for delivery over a guide wire. The catheter may comprise a guidewire lumen along its full length or for a part of its length at a distal region. A guidewire may facilitate delivery of the catheter through tortuous portions of vasculature and may also be used to deliver other devices if needed.

[0314] In some embodiments, the catheter may have a deflectable section in its distal region, such as, for example,

proximal to the imaging or ablation transducers or elements, to provide a function of distorting or manipulating the position or shape of the carrier vessel in which at least a portion of the catheter is positioned (e.g., a jugular vein). The catheter may be deflectable in multiple directions (e.g., 2, 3, or 4 directions). The catheter may have a plurality of deflectable sections that can deflect in different planes. For example, as shown in FIG. 38 a first deflectable section 600 may deflect in a plane aligned with a direction of aim 601 of an ablation transducer to manipulate a vein in this plane, and the catheter may further comprise a second deflectable section 602 that may be deflectable in one or more planes (e.g., 2 planes) that are out of plane with the first deflectable section (e.g., a plane that is 45 to 90 degrees to the right and 45 to 90 degrees to the left of the first deflectable section's plane). The second deflectable section 602 may be distal to the first deflectable section 600. As shown in FIG. 39 the solid line drawing represents a catheter with both deflectable sections 600 and 602 in an undeflected state. The dashed line represents the catheter with the first deflectable section 600 in a deflected state deflected in a first plane. The first deflectable section 600 may have a length of about 2 to 4 cm long and in its fully deflected state have a radius of curvature of about 2 to 4 cm. The dash dot dash line represents the second deflectable section deflected in a second plane. The dash dot dot dash line represents the second deflectable section deflected in a third plane. The schematic illustration of FIG. 39 shows the catheter in undeflected and deflected states unconstrained by a vessel. The second deflectable section may provide a function of additional adjustments or fine tuning of the position of the catheter. Separate pull wires connected to separate actuators may be used to independently control the first and second deflection sections or deflection in different directions. The catheter may further comprise a passively flexible section 603 between the deflectable sections 600 and 602 and an imaging and ablation section 604.

[0315] As shown in FIG. 40, a catheter may be configured to provide deflection at various distances from an imaging and ablation section. For example, the catheter may comprise multiple pull wires set at various lengths or distances from the imaging and ablation section. This may compensate for the ability of a catheter to be advanced or retracted relative to a delivery sheath. Catheter deflection features such as dimension and curvature may be similar to those described herein for a deflectable sheath. The schematic illustration of FIG. 40 shows the catheter in undeflected and deflected states unconstrained by a vessel. FIG. 40 shows a catheter configured to deflect in approximately the same direction as a direction of aim of ablation 610 and the deflection is configured to begin at either a first distance 611 or a second distance 613 from the imaging and ablation section 612. The solid line drawing represents the catheter in an undeflected state. The dashed line represents the catheter deflected at the first distance 611 from the imaging and ablation section 612. The dash dot dash line represents the catheter deflected at the second distance 613. Separate pull wires may be connected to separate actuators to independently control the different deflection sections.

[0316] In some embodiments an ablation and imaging section of a catheter may be fixed relative to a deflectable section, or alternatively may have an adjustable relative position. As shown in FIGS. 41A to 41C a catheter 620 may comprise a passively flexible section 621 that is flexible

enough to allow the imaging and ablation section **622** on a distal region of the catheter to tilt when it is pressed into an inner surface of a vessel wall **623** when a deflectable section **624** is deflected, yet stiff enough to translate pressure to be applied to the vessel wall by the imaging and ablation section that is sufficient to manipulate the vessel or vessel wall. It may be desired to tilt the imaging and ablation section so that its axis **625** is approximately parallel with a longitudinal axis **627** of a common carotid artery **3** that is in an imaging region of the imaging transducers. When an ultrasound image of the common carotid artery is shown as an oval it may be an indication that the axis of the imaging and ablation section is not parallel with the axis of the common carotid artery. Likewise, when the image of the common carotid artery is shown as circular it may indicate that the axes are parallel. A catheter comprising an ablation and imaging section that is adjustable in distance from a deflectable section may be configured to have a passively flexible section that is adjustable in length. FIG. **41A** shows a catheter **620** with a passively deflectable section **621** that is relatively short (e.g., about 10 mm). A shorter passively deflectable section may be stiffer than a longer passively deflectable section which may allow more force to be applied to the vessel wall **623**, may result in relatively less tilt of the imaging and ablation section **622**, or may allow the vessel wall **623** to be moved a greater distance **626**. FIG. **41B** shows a catheter **620** with a passively deflectable section **621** that is relatively mid-length (e.g., about 25 mm). Increasing the length of the passively deflectable section may increase flexibility compared to the shorter length but stiffer than a longer passively deflectable section. Compared to the shorter passively deflectable section, this arrangement may allow less force to be applied to the vessel wall **623**, may result in relatively more tilt of the imaging and ablation section **622**, or may allow the vessel wall **623** to be moved a less distance **626**. FIG. **41C** shows a catheter **620** with a passively deflectable section **621** that is relatively long (e.g., about 50 mm). Increasing the length of the passively deflectable section may further increase flexibility compared to the shorter lengths. Compared to the shorter passively deflectable sections, this arrangement may allow less force to be applied to the vessel wall **623**, may result in relatively more tilt of the imaging and ablation section **622**, or may allow the vessel wall **623** to be moved a less distance **626**.

[0317] For example, the ablation and imaging section of the catheter may be telescopically adjustable relative to the deflectable section. For example, the distance between the imaging and ablation section and the deflectable section may be adjustable between about 0 mm to 50 mm (e.g., between 5 mm and 30 mm, between 5 mm and 20 mm, between 5 mm and 15 mm, between 5 mm and 10 mm). The imaging and ablation section of the catheter may be rotationally adjustable relative to the deflectable section. Rotational adjustability may be provided by a torque wire running from the proximal region of the catheter (e.g., in a handle), to the imaging and ablation section such that turning the torque wire at the proximal end rotates the imaging and ablation section. Alternatively, rotational adjustability may be provided by a torque coil, which may have a lumen running along its axis which may be a conduit for wires or coolant. Alternatively, as shown in FIG. **42** a catheter may comprise an integrated sheath **630** having an axial lumen **631** and an imaging and ablation section **632** may be connected to an elongated tube **633** that is positioned within the lumen and

is connected to a portion of a handle **634**. The inner tube may be moveable within the integrated shaft to allow longitudinal translation **635**, which allows the position of the imaging and ablation section to be adjustable with respect to the integrated shaft. A catheter having an imaging and ablation section that is adjustable in position relative to a deflectable section may further comprise a locking mechanism **636** or coupler to maintain the relative position, which can be adapted to be unlocked to adjust the relative position.

[0318] In an alternative embodiment of a catheter configured to be used without a separate delivery sheath, the catheter may be comprise an integrated sheath that is part of the catheter and not meant to be removed or used separately as shown in FIG. **42**. In this configuration the integrated sheath comprises a deflectable section **637** in the distal region. The deflectable section may be actuated for example with a pull wire **638** connected to an actuator **639** on a handle **640**. The integrated sheath may comprise a lumen **631** along its length through which an elongated tube **633** may pass. The elongated tube may be connected to an imaging and ablation section **632** on its distal region **641** and may further comprise all or some of the wires and coolant lumens required to operate the transducers (e.g., power delivery wires for imaging transducer(s), power delivery wires for ablation transducer(s), sensor wires such as temperature sensor wires, coolant delivery lumen, coolant return lumen, guidewire lumen), not shown. The elongated tube may be rotatable **641** within the integrated sheath **630** so the direction of aim **642** of ablation energy may be adjusted with respect to the direction of deflection **643** of the integrated sheath. Optionally, the elongated tube **633** may be movable within the integrated sheath to translate **635** along its axis, for example within a range of up to about 20 mm, to allow the longitudinal distance **644** between the deflectable section of the integrated sheath and the ablation transducer to be adjusted. In this configuration the imaging and ablation section **632** may have a larger outer diameter than the diameter of the lumen **631** of the integrated sheath since the transducer section does not need to be advanced or retracted through the lumen during use. In FIG. **42** the dashed line represents the catheter in a deflected state with the imaging and ablation section **632** pressing up against an inner wall of a vessel **645** (e.g., jugular vein). A portion of the elongated tube **633** that protrudes from the distal end of the integrated sheath **637** may function as a passively flexible section **646** and may have a length in a range of about 1 to 5 cm, or optionally have an adjustable length as shown in FIG. **42**. When the deflectable section **637** is deflected and the imaging and ablation section **632** is pressed up against a vessel wall **645** the passively flexible section **646** may be sufficiently flexible to allow the imaging and ablation section **632** to tilt yet sufficiently stiff to apply force to the vessel wall **645** to manipulate its position.

[0319] A catheter configured for use without a delivery sheath may be configured to protect an imaging and ablation section of the catheter during delivery. In some embodiments a catheter may comprise a thin membrane defining an echolucent chamber or other components that are fragile and susceptible to damage during delivery. As shown in FIGS. **43A** and **43B** protection of fragile components may be, for example, in the form of a retractable collar **650** or a covering that can cover the fragile components such as the imaging and ablation section **651** during delivery and be opened or moved once positioned near a working site (e.g., near a

carotid bifurcation or target ablation site). The protective cover may also be configured to protect the patient's vasculature during delivery. For example, the cover may be smooth and without sharp edges and have a length 652 that allows for passage over bends in the vasculature (e.g., less than about 20 mm long, less than about 15 mm long). A protective cover may be a deployable structure that is configured to have an undeployed state during catheter delivery and a deployed state for delivery of ablation energy. For example as shown in FIGS. 43C and 43D, a protective cover may comprise two splines 655 and an echolucent membrane material 656. The splines may be positioned on a side of a catheter covering fragile components such as an ablation transducer assembly 657. In the undeployed state, FIG. 43C, the splines 655 and membrane 656 may be held snugly to the side of the catheter. In the deployed state FIG. 43D, the splines may be bent so they are moved out of the path of delivery of ablation energy 658 and the membrane material may be held between the splines and expanded by stretching or unfolding. The spines may be transitioned from the undeployed state to the deployed state by an actuator accessible to the user (e.g., on a handle of the catheter). For example, the actuator may apply tension to a pull wire that moves the ends of the splines toward one another causing them to bend.

Ablation Transducers Adapted and Configured to be Cooled with Saline Solution

[0320] An ablation catheter may comprise an ablation transducer particularly configured to be cooled with a sterile saline solution. Delivering sterile saline solution (e.g., normal saline) to the bloodstream may be safe because of the similar osmolarity of NaCl in blood as opposed to delivering water to the blood stream, which may have unwanted effects. Several embodiments described herein are configured with closed-loop coolant flow, in which coolant is intended to not enter the blood stream. However, if the coolant unintentionally leaks into a patient's blood stream the device or procedure may mitigate any risk of causing undue harm. For example, the catheter or system may be configured to monitor coolant flow rate or pressure and deliver a warning or cease coolant flow if a leak is detected. Another way to mitigate a risk of coolant entering the bloodstream is to use a coolant that is sterile and biocompatible. A small amount of water delivered to the bloodstream may be safe in some patients. However, using a sterile saline solution as a coolant could reduce a risk effect even further. Some embodiments described herein, such as the catheter shown in FIG. 36, intentionally allow coolant to enter the blood stream. It may be particularly important to use saline solution as a coolant for such embodiments.

[0321] Saline solution contains ions and is electrically conductive. An ablation transducer may comprise opposing poles of an electrical circuit connected to opposing faces of a piezoelectric plate. An ablation transducer configured to be cooled with saline solution may comprise provisions that resolve an effect of saline causing a short circuit between the two electrical poles.

[0322] An ablation transducer configured to be cooled with saline may comprise an electrical insulator that prevents saline from creating a short circuit between the two electrical poles. An electrical insulator may be applied to all electrically conductive surfaces of the transducer. Alternatively, as shown in FIG. 44A an electrical insulator may be applied to only electrically conductive surfaces of the trans-

ducer that are in electrical communication with one of the electrical poles 671 and 672. For example, the electrical insulation 665 may be applied to the sides 667 and back 668 of an ablation transducer 666 while the face 669 of the ablation transducer that transmits ultrasound ablation energy 670 toward a target tissue may be free of insulation. Alternatively, if a back side of an ablation transducer is mounted to a backing material and not in communication with coolant then the sides of the transducer and the backing material may be electrically insulated from the saline coolant. Other configurations may be possible in which electrical insulation is applied to at least a part of an ablation transducer, electrical connections that deliver electrical current to an ablation transducer, or electrically conductive components that are in electrical communication with the electrical connections to prevent saline from conducting electrical current between the electrical connections to cause a short circuit or impede function of the ablation transducer.

[0323] Examples of electrical insulation materials may include parylene, urethane, silicone, nylon, PEEK, polyamide, polyimide or other materials that have suitable electrically insulative properties in thin layers. The electrical insulation may be selected to prevent passage of electrical current as well as allow thermal conductance so heat may be removed from the transducer by the coolant, and allow the transducer to vibrate without significant dampening. A method of applying an insulation material may comprise masking a portion of an ablation transducer (e.g., a transmitting face), applying the insulation material (e.g., vapor deposition, thermosetting, adhesive or other coating method), and removing the mask to expose said portion.

[0324] An ablation transducer may be mounted or imbedded in a flex circuit or circuit board, which may facilitate manufacturability as well as provide electrical insulation to prevent saline coolant from short-circuiting the ablation transducer.

[0325] An ablation catheter may be configured to direct flow of saline coolant over an ablation transducer so that it is only in contact with one of the two electrical poles. For example, saline coolant may only contact a transmitting face of an ablation transducer and not the sides or back of the transducer. Coolant may be prevented from contacting the sides and back of the ablation transducer by positioning the transducer in an ablation transducer support component that prevents fluid flow from contacting the sides or back, for example, using a tight seal or glue.

[0326] As shown in FIG. 44B separate streams of coolant flow 680 and 681 that are physically and electrically separated from one another may be passed over an ablation transducer face 682 and backing 683, which may provide a high cooling effect while preventing a short circuit. For example, an ablation transducer may be held in an ablation transducer support 684 with glue 685 which also insulates the sides of the transducer and prevents passage of coolant from the front 682, transmitting side of the transducer to the back side of the transducer or backing material 686. One stream of coolant 680 may be delivered over the front of the transducer and a second stream of coolant 681 may be delivered over the back of the transducer, or over a backing material that the transducer is mounted to. Each stream of coolant may be separated from one another by having separate sources, separate delivery lumens and separate exit lumens.

[0327] As shown in FIG. 44C an embodiment of an ablation catheter having an open-loop transducer cooling system may be configured without a membrane or balloon that creates a chamber around the ablation transducer. Flow of coolant 690 may pass over the transmitting face 691 of an ablation transducer and pass into the blood stream. This configuration may allow for a much greater flow rate of coolant because of reduced resistance to flow compared to a catheter that contains coolant and passes it through a return lumen. Furthermore, a greater flow rate may be allowable in such a configuration when it is not limited by the pressure created in a catheter that comprises a membrane enclosing a chamber, which could cause a failure mode of the membrane seal. An embodiment without a closed chamber around the ablation transducer may comprise electrical insulation to prevent a short circuit as shown in FIG. 44C covering the sides and back face but not the transmitting face. Alternatively electrical insulation may be around the entire ablation transducer. For example, a transducer compatible with saline coolant may be coated with Parylene-C on each electrically conducting surface that contacts saline, the Parylene-C may have a thickness of 10 to 30 microns (e.g., 10 to 25 microns, 20 to 25 microns, 22 microns).

Imaging an Emission from an Ablation Transducer

[0328] Alternative or in addition to incorporating a fiducial marker to create an aiming artifact on an ultrasound-based video, an endovascular imaging and ablation system may be configured to generate an image of ultrasound echoes from a signal delivered from an ablation transducer to provide an accurate indication of a direction of aim of the ablation transducer. An ablation transducer may produce ultrasound signals that are synchronized with the imaging transducer and the imaging transducer can detect the signals. These ultrasound signals would not necessarily function to ablate tissue but primarily to communicate with the imaging transducer(s). The ultrasound signals would however emanate from the catheter ablation transducer and propagate in the same direction into a tissue that ultrasound ablation signals would during ablation. For example, as an ablation transducer may have a resonant frequency of about 20 MHz and an imaging transducer may have a resonant frequency of about 9 MHz. Imaging pulses (e.g., electrical current having a frequency of 9 MHz) may be delivered from a console to the imaging transducer(s), which vibrate sending ultrasound waves into the surrounding tissue. Echoes from the imaging waves bouncing off of tissue return to the imaging transducer(s) to be detected and converted by an imaging system in to an ultrasound-based video representing the surrounding tissue as shown in FIG. 37A. The ablation transducer may either sense and send back synchronized imaging pulses or be activated directly by an amplification of the same imaging pulses. For example, the system console may send a synchronized signal to both the imaging transducer(s) and ablation transducer to image the direction of aim 503 of the ablation transducer to facilitate aiming of the ablation transducer to a desired target 504. Even though the ablation transducer has a higher resonant frequency it has been demonstrated that when 9 MHz imaging pulses are delivered to a transducer assembly having a 20 MHz resonant frequency, the transducer has sufficient bandwidth and sensitivity that results in sufficient ultrasound emissions from the ablation transducer in a range of 9 MHz that are detectable by imaging transducers and may result in image augmentation. These aiming emissions are delivered to tissue in the

same direction that ablative ultrasound emissions would be delivered. The region of tissue exposed to the aiming emission produces additional echoes that are detected by the imaging transducer(s) and result in a zone of enhanced echogenicity on the ultrasound-based video as shown in FIG. 37B as a highlighted sector or wedge 505. Alternatively, an arbitrary phase delay between imaging signals that energize imaging transducers and imaging signals that energize a therapeutic transducer may be introduced or varied resulting in a constructive destructive interference between reflection echoes from ultrasound imaging signals and therapeutic signals. For example a phase delay of 180 degrees may produce destructive interference between imaging and ablative transducer echoes and result in zone of reduced echogenicity on the ultrasound-based video, similar to what is shown in FIG. 37C where aimed direction would be darker than the surrounding image. A user may adjust the direction of aim of the ablation transducer by manipulating the ablation catheter or delivery sheath until the ultrasound-based video shows the aiming emissions directed satisfactorily to the target tissue (e.g., carotid septum).

Use Limiter:

[0329] A medical device or system such as the catheters and systems comprising a console disclosed herein may be configured to limit the use of a device that is intended to be disposable. A medical device may be engineered to be safe and effective and functional within limited parameters such as duration of time that energy is delivered or use in only one patient. In one embodiment a disposable medical device such as any of the catheters disclosed herein may be intended to be used in one patient only, and for one or multiple ablations in the patient. Furthermore, a user may be allowed to disconnect the device from the console or turn off the power to the console before attempting another ablation in the same patient. To stop a device from being used beyond its intended usage parameters the disposable medical device may be configured to provide information to the console allowing the console to determine if the disposable device has exceeded its intended usage allowance. For example, the information provided to the console may comprise an indication of whether or not the disposable device has ever been used before (e.g., if ablation energy has been delivered to it) and an indication of whether or not a predetermined duration of time has passed since the last use or initial use of the disposable device. Limiting use of a disposable device to a predetermined duration of time following its last or initial use may render it impractical to use the device on another patient yet provide sufficient time to use the device multiple times on the same patient. The predetermined duration of time may be for example 1, 2, 3, 4, 5, or 6 hours, or be less than an amount of time typically required between patients for example to sterilize a medical device.

[0330] In one embodiment as shown in FIG. 46A, a disposable medical device 800 (e.g., handle or a disposable medical device) comprises a non-volatile memory storage 802 such as an EEPROM, and a timer 804 such as a timing circuit. The software 801 of the console 803 may read the memory storage 802 and write to it. The memory storage 802 may contain other information in addition to usage limitation information, for example, an identifier that confirms the device is authentic, or device characterization information. The software of the console may read the memory storage 802 to determine if the device 800 is new

or has been used before. If the device **800** has never been used before, the software of the console may set the timer **804** following a timer initiation event, for example when ablation energy is activated for a first time.

[0331] Included within the memory storage **802** are two general-purpose input/output (I/O) signals. A first I/O **806** is configured as an output and is connected to a direct current (DC) voltage regulator **810**. When the timer initiation event (e.g., ablation energy is activated or the disposable medical device is activated) the voltage regulator **810** will enable its output to deliver a fixed voltage to a resistor/capacitor (RC) timing circuit **804**. The DC voltage passes through a charge resistor **812** and charges the timing capacitor **814** up to full voltage within seconds. In this embodiment, setting the timer to full (e.g., filling the timing capacitor to full charge) occurs only with new disposable medical devices. The timing capacitor provides high capacitance, which allows for long duration timing options, and provides fast charge up times (e.g., seconds).

[0332] If a previously used disposable medical device is attached or reattached to the console **803** or another console, the memory device's output is not turned on and the DC regulator **810** will not supply any voltage to the RC timing circuit **804**, thus not changing the charge present on the timing capacitor **814**. When the console **803** is powered off or the disposable medical device **800** is disconnected from the console **803**, all DC power is removed from the disposable medical device **800**. The voltage across the timing capacitor **814** is now allowed to discharge through the discharge resistor **816**. The value of the discharge resistor **816** determines the duration of time (e.g., number of minutes, hours, or days) that the disposable medical device **800** can be re-used within. In order to control any unwanted discharging of the timing capacitor **814**, the use of an ultralow leakage diode **818** and high resistance isolation resistor **820** is used in the signal paths of the timing capacitor **814**. These two items allow this circuit **804** to function accurately when no power is applied to the circuit.

[0333] When a disposable medical device is connected or re-connected to a console or when the console is powered back on, the console sends a command across the serial communications to the memory device **802** to check the second I/O signal **808**, which is set as an input. This signal is connected to a voltage comparator **822**, which will compare the voltage across the timing capacitor **814** to an accurate internal reference voltage level. If the timing capacitor voltage is above this reference voltage, the output of the comparator will be set to 1 indicating that time for allowed use remains. If the voltage is below this reference voltage, the comparator output will be set to 0 indicating that time for allowed use no longer remains. The memory device **802** communicates the status of the voltage comparator back to the console software **801**.

[0334] As shown in a flowchart of FIG. 46B and schematic circuit diagram of FIG. 46A, when a disposable medical device is detected as connected **830**, the console software **801** will communicate with the memory device **802** to check if the disposable medical device **800** has been used before **832** by reading a first bit stored in the memory device **802**. If the disposable medical device usage-bit is set to not used (e.g., the first bit is 0), the console software **801** enables the use of the disposable medical device **800** and sets the timer to 100% **834**, for example by charging up the RC timing circuit **804** by turning on the memory device output signal

through output **806**. The disposable medical device **800** is then used for its intended procedure **836**. However, if the disposable medical device usage bit is set to used (e.g., the first bit is 1), the generator does not charge the RC timing circuit (e.g., by leaving off the memory device output signal **806**) and reads the timer status **838** which indicates if allowable usage time remains or how much allowable usage time remains, for example by reading the memory device input signal **808**. If available time on the disposable medical device remains, (e.g., the RC timing circuit status is high) then the console software **801** enables the use of the disposable medical device and resets the timer to 100% (e.g., charges up the RC timing circuit via turning on the memory device output signal **806**) **834**. If available time on the disposable medical device no longer remains (e.g., the RC timing circuit status is low), then the console software **801** disables the use of the disposable medical device **840** or displays an error message. When the system has completed a medical procedure the Usage-bit may be set (e.g., if it hasn't been set previously) **835**. This allows the device to be connected but never used, which may be useful if a device **800** is connected to a console **801** to be tested or during manufacturing processes. Following the medical procedure, the device **800** may be used for another medical procedure an unlimited number of times as long as it is not disconnected from the console or the console is not powered down **842**. If the device **800** is disconnected from the console or the console is powered off and the catheter is reconnected or connected to another console **844**, then the console software **801** will run through a validation check to see if any allowed usage time remains **838**.

[0335] In another embodiment as shown in a flowchart of FIG. 46C, the algorithm is similar however the console software **801** conducts a validation check **853** and **858** following a medical procedure, or when a new disposable medical device **800** is connected, or when a used disposable medical device is connected. When a used device **800** is connected the console software **801** check is any time remains **858** and if time remains the device is enabled **866** but the timer is not reset to 100% **854** as it is in the embodiment shown in FIG. 46B. In the embodiment the timer is only set once when the device is first connected and the device is disabled **860** after the timer runs out of time. When the system has completed a medical procedure the Usage-bit may be set (e.g., if it hasn't been set previously) **855**. For this embodiment the length of time (e.g., typical length, average, range, maximum) the system is used in a medical procedure **856**, or the number of procedures expected (e.g., typical length, average, range, maximum), or the length of time a device **800** is connected to the powered console **803** and is inactive may be accounted for in setting the timer duration. For example, the timer **804** may be configured so that 100% of the duration is at least the length of time of a procedure multiplied by the number of procedures plus the length of time a device is connected but inactive. Furthermore, the timer duration may account for allowable events that could take place while a catheter is disconnected from the console. For example, it may be acceptable if a physician disconnects the device **800** from the console while repositioning the device to repeat a procedure in a new location in the same patient; or assesses the previous treatment for efficacy; or addresses a patient issue such as anesthesia, safety or comfort; or changes

equipment of part of the system. A reasonable amount of time for acceptable events may be accounted for in the timer duration.

[0336] Optionally, the console software **801** may set a second bit in the memory device **802** after the allowable usage time has expired. This second bit may be protected to prevent over-writing to prevent someone from gaining access to the circuit and applying a charge to the timing circuit to reset the timer of the disposable medical device.

[0337] Optionally, when the console **803** and disposable medical device **800** (i.e., system) are used in a medical procedure **836** of FIG. 46B or **856** of FIG. 46C, the console software **801** may communicate with the memory device **802** and set the disposable medical device usage bit to used (i.e., set the first bit to 1). The first bit may be protected with a write-once-read-many configuration. This means that once the bit is first changed it cannot be reset to 0. Or in other words, once a disposable medical device is set to used, it cannot be reset to un-used when this protection method is applied. The only time a disposable medical device with the usage bit set to used can be used again is if the timer **804** has not fully discharged as described above.

[0338] Optionally, the system may be configured with a limited number of allowable uses, for example, following a use (e.g., delivering ablation energy) the console software **801** may increment a value stored in the EEPROM that may be under write once protection.

[0339] Any medical device that is adapted to receive a signal from a console can include the use limiter, such as any medical device that is adapted to be coupled to an energy delivery console.

Methods of Therapy:

[0340] An ablation energy source such as a high frequency current generator for therapeutic ultrasound may be located external to the patient. The generator may include computer controls to automatically or manually adjust frequency and strength of the energy applied to the catheter, timing and period during which energy is applied, and safety limits to the application of energy. It should be understood that embodiments of energy delivery electrodes described herein may be electrically connected to the generator even though the generator is not explicitly shown or described with each embodiment.

[0341] An endovascular ultrasonic ablation catheter configured to aim ultrasonic energy at a carotid septum may comprise ultrasound visualization capabilities. The ultrasound visualization may comprise Doppler to image blood flow. A catheter may be rotated within an external carotid artery using Doppler to identify when it is aimed through a carotid septum at an internal carotid artery. An ultrasound ablation may be aimed toward the direction of the internal carotid artery and be deposited in a targeted carotid septum.

[0342] An ablated tissue lesion at or near the carotid body may be created by the application of ablation energy from an ablation element in a vicinity of a distal end of the carotid body ablation device. The ablated tissue lesion may disable the carotid body or may suppress the activity of the carotid body or interrupt conduction of afferent nerve signals from a carotid body to sympathetic nervous system. The disabling or suppression of the carotid body reduces the responsiveness of the glomus cells to changes of blood gas composition and effectively reduces activity of afferent carotid body nerves or the chemoreflex gain of the patient.

[0343] A method in accordance with a particular embodiment includes ablating at least one of a patient's carotid bodies based at least in part on identifying the patient as having a sympathetically mediated disease such as cardiac, metabolic, or pulmonary disease such as hypertension, insulin resistance, diabetes, pulmonary hypertension, drug resistant hypertension (e.g., refractory hypertension), congestive heart failure (CHF), or dyspnea from heart failure or pulmonary disease causes.

[0344] A procedure may include diagnosis, selection based on diagnosis, further screening (e.g., baseline assessment of chemosensitivity), treating a patient based at least in part on diagnosis or further screening via a chemoreceptor (e.g., carotid body) ablation procedure such as one of the embodiments disclosed. Additionally, following ablation a method of therapy may involve conducting a post-ablation assessment to compare with the baseline assessment and making decisions based on the assessment (e.g., adjustment of drug therapy, re-treat in new position or with different parameters, or ablate a second chemoreceptor if only one was previously ablated).

[0345] A carotid body ablation procedure may comprise the following steps or a combination thereof: patient sedation, locating a target peripheral chemoreceptor, visualizing a target peripheral chemoreceptor (e.g., carotid body), confirming a target ablation site is or is proximate a peripheral chemoreceptor, confirming a target ablation site is safely distant from vital structures that are preferably protected (e.g., hypoglossal, sympathetic and vagus nerves), providing stimulation (e.g., electrical, mechanical, chemical) to a target site or target peripheral chemoreceptor prior to, during or following an ablation step, monitoring physiological responses to said stimulation, providing temporary nerve block to a target site prior to an ablation step, monitoring physiological responses to said temporary nerve block, anesthetizing a target site, protecting the brain from potential embolism, thermally protecting an arterial or venous wall (e.g., carotid artery, jugular vein) or a medial aspect of an intercarotid septum or vital nerve structures, ablating a target site or peripheral chemoreceptor, monitoring ablation parameters (e.g., temperature, pressure, duration, blood flow in a carotid artery), monitoring physiological responses during ablation and arresting ablation if unsafe or unwanted physiological responses occur before collateral nerve injury becomes permanent, confirming a reduction of chemoreceptor activity (e.g., chemosensitivity, HR, blood pressure, ventilation, sympathetic nerve activity) during or following an ablation step, removing a ablation device, conducting a post-ablation assessment, repeating any steps of the chemoreceptor ablation procedure on another peripheral chemoreceptor in the patient.

[0346] Patient screening, as well as post-ablation assessment may include physiological tests or gathering of information, for example, chemoreflex sensitivity, central sympathetic nerve activity, heart rate, heart rate variability, blood pressure, ventilation, production of hormones, peripheral vascular resistance, blood pH, blood PCO₂, degree of hyperventilation, peak VO₂, VE/VCO₂ slope. Directly measured maximum oxygen uptake (more correctly pVO₂ in heart failure patients) and index of respiratory efficiency VE/VCO₂ slope has been shown to be a reproducible marker of exercise tolerance in heart failure and provide objective and additional information regarding a patient's clinical status and prognosis.

[0347] A method of therapy may include electrical stimulation of a target region, using a stimulation electrode, to confirm proximity to a carotid body. For example, a stimulation signal having a 1-10 milliamps (mA) pulse train at about 20 to 40 Hz with a pulse duration of 50 to 500 microseconds (μ s) that produces a positive carotid body stimulation effect may indicate that the stimulation electrode is within sufficient proximity to the carotid body or nerves of the carotid body to effectively ablate it. A positive carotid body stimulation effect could be increased blood pressure, heart rate, or ventilation concomitant with application of the stimulation. These variables could be monitored, recorded, or displayed to help assess confirmation of proximity to a carotid body. A catheter-based technique, for example, may have a stimulation electrode proximal to the ablation element used for ablation. Alternatively, the ablation element itself may also be used as a stimulation electrode. Alternatively, an energy delivery element that delivers a form of ablative energy that is not electrical, such as a cryogenic ablation applicator, may be configured to also deliver an electrical stimulation signal as described earlier. Yet another alternative embodiment comprises a stimulation electrode that is distinct from an ablation element. For example, during a surgical procedure a stimulation probe can be touched to a suspected carotid body that is surgically exposed. A positive carotid body stimulation effect could confirm that the suspected structure is a carotid body and ablation can commence. Physiological monitors (e.g., heart rate monitor, blood pressure monitor, blood flow monitor, MSNA monitor) may communicate with a computerized stimulation generator, which may also be an ablation generator, to provide feedback information in response to stimulation. If a physiological response correlates to a given stimulation the computerized generator may provide an indication of a positive confirmation.

[0348] Alternatively or in addition a drug known to excite the chemo sensitive cells of the carotid body can be injected directly into the carotid artery or given systemically into a patient's vein or artery in order to elicit hemodynamic or respiratory response. Examples of drugs that may excite a chemoreceptor include nicotine, atropine, Doxapram, Almitrine, hyperkalemia, Theophylline, adenosine, sulfides, Lobeline, Acetylcholine, ammonium chloride, methylamine, potassium chloride, anabasine, coniine, cytosine, acetaldehyde, acetyl ester and the ethyl ether of i-methylcholine, Succinylcholine, Piperidine, monophenol ester of homo-isomuscarine and acetylsalicylamides, alkaloids of veratrum, sodium citrate, adenosinetriphosphate, dinitrophenol, caffeine, theobromine, ethyl alcohol, ether, chloroform, phenyldiguanide, sparteine, coramine (nikethamide), metrazol (pentylenetetrazol), iodomethylate of dimethylaminomethylenedioxyp propane, ethyltrimethylammoniumpropane, trimethylammonium, hydroxytryptamine, papaverine, neostigmine, acidity.

[0349] Described methods may include ultrasound activated drug delivery to carotid complex. Drugs can be incorporated into particles capable of ultrasound activation. Intravenous or direct intratumoral injection of such drug compositions comprising microbubbles, nanoparticles, liposomes and biologically active agents encapsulated in polymers undergo a physical change when subjected to ultrasound beam. The compositions include microemulsions which may create microbubbles as cavitation nuclei in the process of injection and enhance intracellular drug delivery

in the carotid complex. The administration of the ultrasound beam to a carotid complex perfused with encapsulated drugs may stimulate a release of the therapeutic agent to a selected volume affected by the application of ultrasound. In addition to a release of a therapeutic agent the microbubbles generated in situ during an ultrasound irradiation procedure may produce additional guidance to ultrasound imaging.

[0350] A method of therapy may further comprise applying electrical or chemical stimulation to the target area or systemically following ablation to confirm a successful ablation. Heart rate, blood pressure or ventilation may be monitored for change or compared to the reaction to stimulation prior to ablation to assess if the targeted carotid body was ablated. Post-ablation stimulation may be done with the same apparatus used to conduct the pre-ablation stimulation. Physiological monitors (e.g., heart rate monitor, blood pressure monitor, blood flow monitor, MSNA monitor) may communicate with a computerized stimulation generator, which may also be an ablation generator, to provide feedback information in response to stimulation. If a physiological response correlated to a given stimulation is reduced following an ablation compared to a physiological response prior to the ablation, the computerized generator may provide an indication ablation efficacy or possible procedural suggestions such as repeating an ablation, adjusting ablation parameters, changing position, ablating another carotid body or chemosensor, or concluding the procedure.

[0351] The devices described herein may also be used to temporarily stun or block nerve conduction via electrical neural blockade. A temporary nerve block may be used to confirm position of an ablation element prior to ablation. For example, a temporary nerve block may block nerves associated with a carotid body, which may result in a physiological effect to confirm the position may be effective for ablation. Furthermore, a temporary nerve block may block vital nerves such as vagal, hypoglossal or sympathetic nerves that are preferably avoided, resulting in a physiological effect (e.g., physiological effects may be noted by observing the patient's eyes, tongue, throat or facial muscles or by monitoring patient's heart rate and respiration). This may alert a user that the position is not in a safe location. Likewise absence of a physiological effect indicating a temporary nerve block of such vital nerves in combination with a physiological effect indicating a temporary nerve block of carotid body nerves may indicate that the position is in a safe and effective location for carotid body ablation.

[0352] Important nerves may be located in proximity of the target site and may be inadvertently and unintentionally injured. Neural stimulation or blockade can help identify that these nerves are in the ablation zone before the irreversible ablation occurs. These nerves may include the following:

[0353] Vagus Nerve Bundle—The vagus is a bundle of nerves that carry separate functions, for example a) branchial motor neurons (efferent special visceral) which are responsible for swallowing and phonation and are distributed to pharyngeal branches, superior and inferior laryngeal nerves; b) visceral motor (efferent general visceral) which are responsible for involuntary muscle and gland control and are distributed to cardiac, pulmonary, esophageal, gastric, celiac plexuses, and muscles, and glands of the digestive tract; c) visceral sensory (afferent general visceral) which are responsible for visceral sensibility and are distributed to cervical, thoracic, abdominal fibers, and carotid and aortic

bodies; d) visceral sensory (afferent special visceral) which are responsible for taste and are distributed to epiglottis and taste buds; e) general sensory (afferent general somatic) which are responsible for cutaneous sensibility and are distributed to auricular branch to external ear, meatus, and tympanic membrane. Dysfunction of the vagus may be detected by a) vocal changes caused by nerve damage (damage to the vagus nerve can result in trouble with moving the tongue while speaking, or hoarseness of the voice if the branch leading to the larynx is damaged); b) dysphagia due to nerve damage (the vagus nerve controls many muscles in the palate and tongue which, if damaged, can cause difficulty with swallowing); c) changes in gag reflex (the gag reflex is controlled by the vagus nerve and damage may cause this reflex to be lost, which can increase the risk of choking on saliva or food); d) hearing loss due to nerve damage (hearing loss may result from damage to the branch of the vagus nerve that innervates the concha of the ear); e) cardiovascular problems due to nerve damage (damage to the vagus nerve can cause cardiovascular side effects including irregular heartbeat and arrhythmia); or f) digestive problems due to nerve damage (damage to the vagus nerve may cause problems with contractions of the stomach and intestines, which can lead to constipation).

[0354] Superior Laryngeal Nerve—the superior laryngeal nerve is a branch of the vagus nerve bundle. Functionally, the superior laryngeal nerve function can be divided into sensory and motor components. The sensory function provides a variety of afferent signals from the supraglottic larynx. Motor function involves motor supply to the ipsilateral cricothyroid muscle. Contraction of the cricothyroid muscle tilts the cricoid lamina backward at the cricothyroid joint causing lengthening, tensing and adduction of vocal folds causing an increase in the pitch of the voice generated. Dysfunction of the superior laryngeal nerve may change the pitch of the voice and causes an inability to make explosive sounds. A bilateral palsy presents as a tiring and hoarse voice.

[0355] Cervical Sympathetic Nerve—The cervical sympathetic nerve provides efferent fibers to the internal carotid nerve, external carotid nerve, and superior cervical cardiac nerve. It provides sympathetic innervation of the head, neck and heart. Organs that are innervated by the sympathetic nerves include eyes, lacrimal gland and salivary glands. Dysfunction of the cervical sympathetic nerve includes Horner's syndrome, which is very identifiable and may include the following reactions: a) partial ptosis (drooping of the upper eyelid from loss of sympathetic innervation to the superior tarsal muscle, also known as Müller's muscle); b) upside-down ptosis (slight elevation of the lower lid); c) anhidrosis (decreased sweating on the affected side of the face); d) miosis (small pupils, for example small relative to what would be expected by the amount of light the pupil receives or constriction of the pupil to a diameter of less than two millimeters, or asymmetric, one-sided constriction of pupils); e) enophthalmos (an impression that an eye is sunken in); f) loss of ciliospinal reflex (the ciliospinal reflex, or pupillary-skin reflex, consists of dilation of the ipsilateral pupil in response to pain applied to the neck, face, and upper trunk. If the right side of the neck is subjected to a painful stimulus, the right pupil dilates about 1-2 mm from baseline. This reflex is absent in Horner's syndrome and lesions involving the cervical sympathetic fibers.)

Overview:

[0356] Ablation of a target ablation site (e.g., peripheral chemoreceptor, carotid body) via directed energy in patients having sympathetically mediated disease and augmented chemoreflex (e.g., high afferent nerve signaling from a carotid body to the central nervous system as in some cases indicated by high peripheral chemosensitivity) has been conceived to reduce peripheral chemosensitivity and reduce afferent signaling from peripheral chemoreceptors to the central nervous system. Additionally, ablation of a target ablation site (e.g., peripheral chemoreceptor, carotid body) via a transvenous endovascular approach in patients having sympathetically mediated disease and augmented chemoreflex (e.g., high afferent nerve signaling from a carotid body to the central nervous system as in some cases indicated by high peripheral chemosensitivity) has been conceived to reduce peripheral chemosensitivity and reduce afferent signaling from peripheral chemoreceptors to the central nervous system. The expected reduction of chemoreflex activity and sensitivity to hypoxia and other stimuli such as blood flow, blood CO₂, glucose concentration or blood pH can directly reduce afferent signals from chemoreceptors and produce at least one beneficial effect such as the reduction of central sympathetic activation, reduction of the sensation of breathlessness (dyspnea), vasodilation, increase of exercise capacity, reduction of blood pressure, reduction of sodium and water retention, redistribution of blood volume to skeletal muscle, reduction of insulin resistance, reduction of hyperventilation, reduction of tachypnea, reduction of hypocapnia, increase of baroreflex and barosensitivity of baroreceptors, increase of vagal tone, or improve symptoms of a sympathetically mediated disease and may ultimately slow down the disease progression and extend life. It is understood that a sympathetically mediated disease that may be treated with carotid body ablation may comprise elevated sympathetic tone, an elevated sympathetic/parasympathetic activity ratio, autonomic imbalance primarily attributable to central sympathetic tone being abnormally or undesirably high, or heightened sympathetic tone at least partially attributable to afferent excitation traceable to hypersensitivity or hyperactivity of a peripheral chemoreceptor (e.g., carotid body). In some important clinical cases where baseline hypocapnia or tachypnea is present, reduction of hyperventilation and breathing rate may be expected. It is understood that hyperventilation in the context herein means respiration in excess of metabolic needs on the individual that generally leads to slight but significant hypocapnea (blood CO₂ partial pressure below normal of approximately 40 mmHg, for example in the range of 33 to 38 mmHg).

[0357] Patients having CHF or hypertension concurrent with heightened peripheral chemoreflex activity and sensitivity often react as if their system was hypercapnic even if it is not. The reaction is often to hyperventilate, a maladaptive attempt to rid the system of CO₂, thus overcompensating and creating a hypocapnic and alkalotic system. Some researchers attribute this hypersensitivity/hyperactivity of the carotid body to the direct effect of catecholamines, hormones circulating in excessive quantities in the blood stream of CHF patients. The procedure may be particularly useful to treat such patients who are hypocapnic and possibly alkalotic resulting from high tonic output from carotid bodies. Such patients are particularly predisposed to periodic breathing and central apnea hypopnea type events that

cause arousal, disrupt sleep, cause intermittent hypoxia and are by themselves detrimental and difficult to treat.

[0358] It is appreciated that periodic breathing of Cheyne Stokes pattern occurs in patients during sleep, exercise and even at rest as a combination of central hypersensitivity to CO₂, peripheral chemosensitivity to O₂ and CO₂ and prolonged circulatory delay. All these parameters are often present in CHF patients that are at high risk of death. Thus, patients with hypocapnea, CHF, high chemosensitivity and prolonged circulatory delay, and specifically ones that exhibit periodic breathing at rest or during exercise or induced by hypoxia are likely beneficiaries of the proposed therapy.

[0359] Hyperventilation is defined as breathing in excess of a person's metabolic need at a given time and level of activity. Hyperventilation is more specifically defined as minute ventilation in excess of that needed to remove CO₂ from blood in order to maintain blood CO₂ in the normal range (e.g., around 40 mmHg partial pressure). For example, patients with arterial blood PCO₂ in the range of 32-37 mmHg can be considered hypocapnic and in hyperventilation.

[0360] For the purpose of this disclosure hyperventilation is equivalent to abnormally low levels of carbon dioxide in the blood (e.g., hypocapnia, hypocapnea, or hypocarbia) caused by overbreathing. Hyperventilation is the opposite of hypoventilation (e.g., underventilation) that often occurs in patients with lung disease and results in high levels of carbon dioxide in the blood (e.g., hypercapnia or hypercarbia).

[0361] A low partial pressure of carbon dioxide in the blood causes alkalosis, because CO₂ is acidic in solution and reduced CO₂ makes blood pH more basic, leading to lowered plasma calcium ions and nerve and muscle excitability. This condition is undesirable in cardiac patients since it can increase probability of cardiac arrhythmias.

[0362] Alkalemia may be defined as abnormal alkalinity, or increased pH of the blood. Respiratory alkalosis is a state due to excess loss of carbon dioxide from the body, usually as a result of hyperventilation. Compensated alkalosis is a form in which compensatory mechanisms have returned the pH toward normal. For example, compensation can be achieved by increased excretion of bicarbonate by the kidneys.

[0363] Compensated alkalosis at rest can become uncompensated during exercise or as a result of other changes of metabolic balance. Thus the invented method is applicable to treatment of both uncompensated and compensated respiratory alkalosis.

[0364] Tachypnea means rapid breathing. For the purpose of this disclosure a breathing rate of about 6 to 16 breaths per minute at rest is considered normal but there is a known benefit to lower rate of breathing in cardiac patients. Reduction of tachypnea can be expected to reduce respiratory dead space, increase breathing efficiency, and increase parasympathetic tone.

Therapy Example: Role of Chemoreflex and Central Sympathetic Nerve Activity in CHF

[0365] Chronic elevation in sympathetic nerve activity (SNA) is associated with the development and progression of certain types of hypertension and contributes to the progression of congestive heart failure (CHF). It is also known that sympathetic excitatory cardiac, somatic, and

central/peripheral chemoreceptor reflexes are abnormally enhanced in CHF and hypertension (Ponikowski, 2011 and Giannoni, 2008 and 2009).

[0366] Arterial chemoreceptors serve an important regulatory role in the control of alveolar ventilation. They also exert a powerful influence on cardiovascular function.

[0367] Delivery of Oxygen (O₂) and removal of Carbon Dioxide (CO₂) in the human body is regulated by two control systems, behavioral control and metabolic control. The metabolic ventilatory control system drives our breathing at rest and ensures optimal cellular homeostasis with respect to pH, partial pressure of carbon dioxide (PCO₂), and partial pressure of oxygen (PO₂). Metabolic control uses two sets of chemoreceptors that provide a fine-tuning function: the central chemoreceptors located in the ventral medulla of the brain and the peripheral chemoreceptors such as the aortic chemoreceptors and the carotid body chemoreceptors. The carotid body, a small, ovoid-shaped (often described as a grain of rice), and highly vascularized organ is situated in or near the carotid bifurcation, where the common carotid artery branches in to an internal carotid artery (IC) and external carotid artery (EC). The central chemoreceptors are sensitive to hypercapnia (high PCO₂), and the peripheral chemoreceptors are sensitive to hypercapnia and hypoxia (low blood PO₂). Under normal conditions activation of the sensors by their respective stimuli results in quick ventilatory responses aimed at the restoration of cellular homeostasis.

[0368] As early as 1868, Pflüger recognized that hypoxia stimulated ventilation, which spurred a search for the location of oxygen-sensitive receptors both within the brain and at various sites in the peripheral circulation. When Corneille Heymans and his colleagues observed that ventilation increased when the oxygen content of the blood flowing through the bifurcation of the common carotid artery was reduced (winning him the Nobel Prize in 1938), the search for the oxygen chemosensor responsible for the ventilatory response to hypoxia was largely considered accomplished.

[0369] The persistence of stimulatory effects of hypoxia in the absence (after surgical removal) of the carotid chemoreceptors (e.g., the carotid bodies) led other investigators, among them Julius Comroe, to ascribe hypoxic chemosensitivity to other sites, including both peripheral sites (e.g., aortic bodies) and central brain sites (e.g., hypothalamus, pons and rostral ventrolateral medulla). The aortic chemoreceptor, located in the aortic body, may also be an important chemoreceptor in humans with significant influence on vascular tone and cardiac function.

Carotid Body Chemoreflex:

[0370] The carotid body is a small cluster of chemoreceptors (also known as glomus cells) and supporting cells located near, and in most cases directly at, the medial side of the bifurcation (fork) of the carotid artery, which runs along both sides of the throat.

[0371] These organs act as sensors detecting different chemical stimuli from arterial blood and triggering an action potential in the afferent fibers that communicate this information to the Central Nervous System (CNS). In response, the CNS activates reflexes that control heart rate (HR), renal function and peripheral blood circulation to maintain the desired homeostasis of blood gases, O₂ and CO₂, and blood pH. This closed loop control function that involves blood gas chemoreceptors is known as the carotid body

chemoreflex (CBC). The carotid body chemoreflex is integrated in the CNS with the carotid sinus baroreflex (CSB) that maintains arterial blood pressure. In a healthy organism these two reflexes maintain blood pressure and blood gases within a narrow physiologic range. Chemosensors and barosensors in the aortic arch contribute redundancy and fine-tuning function to the closed loop chemoreflex and baroreflex. In addition to sensing blood gasses, the carotid body is now understood to be sensitive to blood flow and velocity, blood pH and glucose concentration. Thus it is understood that in conditions such as hypertension, CHF, insulin resistance, diabetes and other metabolic derangements afferent signaling of carotid body nerves may be elevated. Carotid body hyperactivity may be present even in the absence of detectable hypersensitivity to hypoxia and hypercapnia that are traditionally used to index carotid body function. The purpose of the proposed therapy is therefore to remove or reduce afferent neural signals from a carotid body and reduce carotid body contribution to central sympathetic tone.

[0372] The carotid sinus baroreflex is accomplished by negative feedback systems incorporating pressure sensors (e.g., baroreceptors) that sense the arterial pressure. Baroreceptors also exist in other places, such as the aorta and coronary arteries. Important arterial baroreceptors are located in the carotid sinus, a slight dilatation of the internal carotid artery **201** at its origin from the common carotid. The carotid sinus baroreceptors are close to but anatomically separate from the carotid body. Baroreceptors respond to stretching of the arterial wall and communicate blood pressure information to CNS. Baroreceptors are distributed in the arterial walls of the carotid sinus while the chemoreceptors (glomus cells) are clustered inside the carotid body. This makes the selective reduction of chemoreflex described in this application possible while substantially sparing the baroreflex.

[0373] The carotid body exhibits great sensitivity to hypoxia (low threshold and high gain). In chronic Congestive Heart Failure (CHF), the sympathetic nervous system activation that is directed to attenuate systemic hypoperfusion at the initial phases of CHF may ultimately exacerbate the progression of cardiac dysfunction that subsequently increases the extra-cardiac abnormalities, a positive feedback cycle of progressive deterioration, a vicious cycle with ominous consequences. It was thought that much of the increase in the sympathetic nerve activity (SNA) in CHF was based on an increase of sympathetic flow at a level of the CNS and on the depression of arterial baroreflex function. In the past several years, it has been demonstrated that an increase in the activity and sensitivity of peripheral chemoreceptors (heightened chemoreflex function) also plays an important role in the enhanced SNA that occurs in CHF.

Role of Altered Chemoreflex in CHF:

[0374] As often happens in chronic disease states, chemoreflexes that are dedicated under normal conditions to maintaining homeostasis and correcting hypoxia contribute to increase the sympathetic tone in patients with CHF, even under normoxic conditions. The understanding of how abnormally enhanced sensitivity of the peripheral chemosensors, particularly the carotid body, contributes to the tonic elevation in SNA in patients with CHF has come from several studies in animals. According to one theory, the local

angiotensin receptor system plays a fundamental role in the enhanced carotid body chemoreceptor sensitivity in CHF. In addition, evidence in both CHF patients and animal models of CHF has clearly established that the carotid body chemoreflex is often hypersensitive in CHF patients and contributes to the tonic elevation in sympathetic function. This derangement derives from altered function at the level of both the afferent and central pathways of the reflex arc. The mechanisms responsible for elevated afferent activity from the carotid body in CHF are not yet fully understood.

[0375] Regardless of the exact mechanism behind the carotid body hypersensitivity, the chronic sympathetic activation driven from the carotid body and other autonomic pathways leads to further deterioration of cardiac function in a positive feedback cycle. As CHF ensues, the increasing severity of cardiac dysfunction leads to progressive escalation of these alterations in carotid body chemoreflex function to further elevate sympathetic activity and cardiac deterioration. The trigger or causative factors that occur in the development of CHF that sets this cascade of events in motion and the time course over which they occur remain obscure. Ultimately, however, causative factors are tied to the cardiac pump failure and reduced cardiac output. According to one theory, within the carotid body, a progressive and chronic reduction in blood flow may be the key to initiating the maladaptive changes that occur in carotid body chemoreflex function in CHF.

[0376] There is sufficient evidence that there is increased peripheral and central chemoreflex sensitivity in heart failure, which is likely to be correlated with the severity of the disease. There is also some evidence that the central chemoreflex is modulated by the peripheral chemoreflex. According to current theories, the carotid body is the predominant contributor to the peripheral chemoreflex in humans; the aortic body having a minor contribution.

[0377] Although the mechanisms responsible for altered central chemoreflex sensitivity remain obscure, the enhanced peripheral chemoreflex sensitivity can be linked to a depression of nitric oxide production in the carotid body affecting afferent sensitivity, and an elevation of central angiotensin II affecting central integration of chemoreceptor input. The enhanced chemoreflex may be responsible, in part, for the enhanced ventilatory response to exercise, dyspnea, Cheyne-Stokes breathing, and sympathetic activation observed in chronic heart failure patients. The enhanced chemoreflex may be also responsible for hyperventilation and tachypnea (e.g., fast breathing) at rest and exercise, periodic breathing during exercise, rest and sleep, hypocapnia, vasoconstriction, reduced peripheral organ perfusion and hypertension.

Dyspnea:

[0378] Shortness of breath, or dyspnea, is a feeling of difficult or labored breathing that is out of proportion to the patient's level of physical activity. It is a symptom of a variety of different diseases or disorders and may be either acute or chronic. Dyspnea is the most common complaint of patients with cardiopulmonary diseases.

[0379] Dyspnea is believed to result from complex interactions between neural signaling, the mechanics of breathing, and the related response of the central nervous system. A specific area has been identified in the mid-brain that may influence the perception of breathing difficulties.

[0380] The experience of dyspnea depends on its severity and underlying causes. The feeling itself results from a combination of impulses relayed to the brain from nerve endings in the lungs, rib cage, chest muscles, or diaphragm, combined with the perception and interpretation of the sensation by the patient. In some cases, the patient's sensation of breathlessness is intensified by anxiety about its cause. Patients describe dyspnea variously as unpleasant shortness of breath, a feeling of increased effort or tiredness in moving the chest muscles, a panicky feeling of being smothered, or a sense of tightness or cramping in the chest wall.

[0381] The four generally accepted categories of dyspnea are based on its causes: cardiac, pulmonary, mixed cardiac or pulmonary, and non-cardiac or non-pulmonary. The most common heart and lung diseases that produce dyspnea are asthma, pneumonia, COPD, and myocardial ischemia or heart attack (myocardial infarction). Foreign body inhalation, toxic damage to the airway, pulmonary embolism, congestive heart failure (CHF), anxiety with hyperventilation (panic disorder), anemia, and physical deconditioning because of sedentary lifestyle or obesity can produce dyspnea. In most cases, dyspnea occurs with exacerbation of the underlying disease. Dyspnea also can result from weakness or injury to the chest wall or chest muscles, decreased lung elasticity, obstruction of the airway, increased oxygen demand, or poor pumping action of the heart that results in increased pressure and fluid in the lungs, such as in CHF.

[0382] Acute dyspnea with sudden onset is a frequent cause of emergency room visits. Most cases of acute dyspnea involve pulmonary (lung and breathing) disorders, cardiovascular disease, or chest trauma. Sudden onset of dyspnea (acute dyspnea) is most typically associated with narrowing of the airways or airflow obstruction (bronchospasm), blockage of one of the arteries of the lung (pulmonary embolism), acute heart failure or myocardial infarction, pneumonia, or panic disorder.

[0383] Chronic dyspnea is different. Long-standing dyspnea (chronic dyspnea) is most often a manifestation of chronic or progressive diseases of the lung or heart, such as COPD, which includes chronic bronchitis and emphysema. The treatment of chronic dyspnea depends on the underlying disorder. Asthma can often be managed with a combination of medications to reduce airway spasms and removal of allergens from the patient's environment. COPD requires medication, lifestyle changes, and long-term physical rehabilitation. Anxiety disorders are usually treated with a combination of medication and psychotherapy.

[0384] Although the exact mechanism of dyspnea in different disease states is debated, there is no doubt that the CBC plays some role in most manifestations of this symptom. Dyspnea seems to occur most commonly when afferent input from peripheral receptors is enhanced or when cortical perception of respiratory work is excessive.

Surgical Removal of the Glomus and Resection of Carotid Body Nerves:

[0385] A surgical treatment for asthma, removal of the carotid body or glomus (glomectomy), was described by Japanese surgeon Komei Nakayama in 1940s. According to Nakayama in his study of 4,000 patients with asthma, approximately 80% were cured or improved six months after surgery and 58% allegedly maintained good results after five years. Komei Nakayama performed most of his surgeries

while at the Chiba University during World War II. Later in the 1950's, a U.S. surgeon, Dr. Overholt, performed the Nakayama operation on 160 U.S. patients. He felt it necessary to remove both carotid bodies in only three cases. He reported that some patients feel relief the instant when the carotid body is removed, or even earlier, when it is inactivated by an injection of procaine (Novocain).

[0386] Overholt, in his paper *Glomectomy for Asthma* published in *Chest* in 1961, described surgical glomectomy the following way: "A two-inch incision is placed in a crease line in the neck, one-third of the distance between the angle of the mandible and clavicle. The platysma muscle is divided and the sternocleidomastoid retracted laterally. The dissection is carried down to the carotid sheath exposing the bifurcation. The superior thyroid artery is ligated and divided near its take-off in order to facilitate rotation of the carotid bulb and expose the medial aspect of the bifurcation. The carotid body is about the size of a grain of rice and is hidden within the adventitia of the vessel and is of the same color. The perivascular adventitia is removed from one centimeter above to one centimeter below the bifurcation. This severs connections of the nerve plexus, which surrounds the carotid body. The dissection of the adventitia is necessary in order to locate and identify the body. It is usually located exactly at the point of bifurcation on its medial aspect. Rarely, it may be found either in the center of the crotch or on the lateral wall. The small artery entering the carotid body is clamped, divided, and ligated. The upper stalk of tissue above the carotid body is then clamped, divided, and ligated."

[0387] In January 1965, the *New England Journal of Medicine* published a report of 15 cases in which there had been unilateral removal of the cervical glomus (carotid body) for the treatment of bronchial asthma, with no objective beneficial effect. This effectively stopped the practice of glomectomy to treat asthma in the U.S.

[0388] Winter developed a technique for separating nerves that contribute to the carotid sinus nerves into two bundles, carotid sinus (baroreflex) and carotid body (chemoreflex), and selectively cutting out the latter. The Winter technique is based on his discovery that carotid sinus (baroreflex) nerves are predominantly on the lateral side of the carotid bifurcation and carotid body (chemoreflex) nerves are predominantly on the medial side.

Neuromodulation of the Carotid Body Chemoreflex:

[0389] Hlavka in U.S. Patent Application Publication 2010/0070004 filed Aug. 7, 2009, describes implanting an electrical stimulator to apply electrical signals, which block or inhibit chemoreceptor signals in a patient suffering dyspnea. Hlavka teaches that "some patients may benefit from the ability to reactivate or modulate chemoreceptor functioning." Hlavka focuses on neuromodulation of the chemoreflex by selectively blocking conduction of nerves that connect the carotid body to the CNS. Hlavka describes a traditional approach of neuromodulation with an implantable electric pulse generator that does not modify or alter tissue of the carotid body or chemoreceptors.

[0390] The central chemoreceptors are located in the brain and are difficult to access. The peripheral chemoreflex is modulated primarily by carotid bodies that are more accessible. Previous clinical practice had very limited clinical success with the surgical removal of carotid bodies to treat asthma in 1940s and 1960s.

Renal Denervation:

[0391] The embodiments of systems or devices disclosed herein may be used to ablate target tissue near a body lumen (e.g., an artery, vein, blood vessel, respiratory lumen, esophagus, bronchioles, a digestive lumen) by placing the ablation catheter either having integrated imaging elements or configured to be used with a separate imaging catheter (e.g., ultrasound imaging) in the lumen, using the imaging element to provide an image of tissue (e.g., an anatomical landmark or target tissue) to facilitate directing ablation energy toward target tissue, and delivering ablation energy (e.g., ultrasound ablation energy, chemical agent, radiofrequency electrical current) to the target tissue. The target tissue may be within a range from 0 mm to 2 cm (e.g., 0 to 1 cm, 0 to 1.5 cm, 0 to 0.5 cm) from the wall of the lumen. Renal denervation may be an alternative procedure to carotid body ablation for which the disclosed device or system may be used. A renal denervation procedure incorporating the disclosed devices and systems may comprise delivering an ablation catheter to a renal vein and directing ablation energy from the catheter to renal nerves. The target renal nerves may be in or proximate to renal artery adventitia, in tissue between a renal artery bifurcation, in tissue around a renal artery proximate a renal artery ostium from an aorta. Other renal denervation procedures often involve delivering radiopaque contrast agent to a renal artery for radiographic imaging. However, some patients' kidneys cannot tolerate contrast agent. The proposed procedure may be performed without delivering contrast or a device to a renal artery. Imaging may be used to identify a renal artery bifurcation and ablation energy may be delivered to the tissue between the bifurcating arteries. This volume of tissue may be referred to as a renal artery bifurcation septum and contains a high concentration of renal nerves. In addition or alternatively, imaging may be used to identify location of small blood vessels in target zones that could impede effective ablation by acting as a heat sink removing thermal energy. Ablation energy may be delivered to regions in the target zones that do not comprise small vessel heat sinks.

Embodiments

[0392] 1. An ultrasound ablation catheter configured to interact with an ultrasound imaging catheter, the ultrasound ablation catheter comprising:

[0393] a distal region and a proximal region;

[0394] an Imaging catheter lumen to receive therethrough an Imaging catheter extending from the proximal region to the distal region;

[0395] an echolucent chamber at the distal region; and

[0396] an ultrasound ablation transducer within the echolucent chamber,

[0397] wherein the Imaging catheter lumen is configured to position the Imaging catheter within a direction of aim of the ultrasound ablation transducer in a deployed state and out of the direction of aim in a retracted state.

2. A catheter of embodiment 1 further comprising a cooling fluid lumen for cooling the echolucent chamber.

3. A catheter of embodiment 1 wherein the direction of aim of the ultrasound ablation catheter is in a radial direction from the catheter within an imaging plane generated by the Imaging catheter when in a deployed state.

4. A catheter of embodiment 1 further comprising a mating feature at the proximal region for coupling with the Imaging

catheter wherein the mating feature is associated with an actuator that transitions the Imaging catheter between a deployed state and a retracted state.

5. A catheter of embodiment 1 wherein the catheter is configured for controllable deflection of the distal region, wherein a plane of deflection is coplanar with the ultrasound ablation transducer.

6. A catheter of embodiment 1 further comprising a lumen configured to receive a guidewire.

7. An ultrasound ablation catheter configured to interact with an ultrasound imaging catheter having an ultrasound imaging transducer, the ultrasound ablation catheter comprising:

[0398] a distal region and a proximal region;

[0399] an Imaging catheter lumen configured to receive therethrough an Imaging catheter extending from the proximal region to the distal region;

[0400] an echolucent chamber at the distal region; and

[0401] an ultrasound ablation transducer within the echolucent chamber,

[0402] wherein the imaging catheter lumen is configured to position the ultrasound imaging transducer of the ultrasound imaging catheter distal to the ultrasound ablation transducer such that the ultrasound ablation transducer may deliver ablation energy while the ultrasound imaging transducer is transmitting and receiving waves to provide an image while ablating.

8. An ultrasound ablation catheter of embodiments 1 or 7 comprising an acoustic insulator to shield passage of ultrasound ablation energy, wherein the acoustic insulator comprises microspheres of air embedded in epoxy.

9. An ultrasound ablation catheter of embodiment 8 wherein the acoustic insulator has a thickness of about 200 to 300 microns and comprises microspheres having a diameter in a range of about 15 to 25 microns and microspheres having a diameter in a range of about 180 to 210 microns.

10. An ultrasound ablation catheter of embodiment 1 or 7 comprising a fiducial marker having a position with respect to the imaging transducer and the direction of aim of the ablation transducer.

11. An ultrasound ablation catheter of embodiment 10 wherein the fiducial marker is a hollow tube filled with air.

12. An ultrasound ablation catheter, comprising:

[0403] a distal assembly comprising an ultrasound ablation transducer, an echolucent shell, and an ablation direction fiducial marker, the echolucent shell at least partially defining a distal chamber, the ultrasound ablation transducer disposed within the distal chamber, the distal assembly adapted to house therein an ultrasound imaging transducer,

[0404] the ablation direction fiducial marker positioned relative to the ultrasound ablation transducer and adapted to, when an ultrasound imaging transducer is positioned and activated within the distal assembly, create an aiming artifact on an image created by the ultrasound imaging transducer, the aiming artifact adapted to be used to indicate a direction of ablation; and

[0405] an elongate shaft extending proximally from the distal assembly.

13. The catheter of embodiment 12 wherein the ablation direction fiducial marker is axially aligned with the ultrasound imaging catheter when the ultrasound image transducer is in an active position in the distal assembly.

14. The catheter of embodiment 12 wherein the ablation direction fiducial marker is disposed relative to the ultrasound ablation transducer such that the direction of the

ablation energy emitted from the ultrasound ablation transducer can be determined based on the location of the indicator on the image.

15. The catheter of embodiment 14 wherein the ablation direction fiducial marker is secured to the echolucent shell.

16. The catheter of embodiment 15 wherein echolucent shell comprises first and second membranes, the ablation direction fiducial marker secured between the first and second membranes.

17. The catheter of embodiment 16 wherein the ablation direction fiducial marker has a curved configuration.

18. The catheter of embodiment 12 wherein the ablation direction fiducial marker has a curved configuration.

19. The catheter of embodiment 12 wherein the ablation direction fiducial marker has a configuration that is a partial tubular member.

20. The catheter of embodiment 12 wherein the ablation direction fiducial marker is an extension of a support member disposed proximal to the ablation direction fiducial marker.

21. The catheter of embodiment 12 wherein the ablation direction fiducial marker is an echo-opaque material.

22. The catheter of embodiment 21 wherein the ablation direction fiducial marker comprises stainless steel.

23. The catheter of embodiment 12 wherein the ultrasound ablation catheter is configured to be inserted through a jugular vein of a patient and wherein the ultrasound ablation transducer is configured to be placed in proximity to a target ablation site including a carotid body.

24. The catheter of embodiment 12 wherein the distal assembly further comprises a lumen therein configured to receive therethrough an ultrasound imaging catheter.

25. The catheter of embodiment 12 wherein the ultrasound ablation transducer is a flat transducer with an axial axis that is parallel to the longitudinal axis of the elongate shaft in a straight configuration.

26. The catheter of embodiment 25 wherein the flat transducer is disposed in an outer radial portion of the distal region.

27. The catheter of embodiment 12 wherein the echolucent shell has a first thickness at a first axial location of the ablation ultrasound transducer, and a second thickness greater than the first thickness at a second axial location distal to the ablation ultrasound transducer.

28. The catheter of embodiment 12 wherein the echolucent shell comprises at least first and second membrane sections that are affixed together in the second axial location.

29. The catheter of embodiment 12 further comprising a fluid lumen, the fluid lumen in fluid communication with the ultrasound ablation transducer, the fluid lumen also comprising an electrical connector in electrical communication with the ablation ultrasound transducer.

30. The catheter of embodiment 12 further comprising an ablation transducer support secured to and extending distally from at least a portion of the elongate shaft, the ablation ultrasound transducer mounted to the ablation transducer support.

31. The catheter of embodiment 30 further comprising a plate secured between the ablation ultrasound transducer and the ablation transducer support.

32. The catheter of embodiment 30 wherein the ablation transducer support further comprises a lumen adapted to receive an ultrasound imaging catheter therein.

33. The catheter of embodiment 30 wherein the ablation transducer support comprises at least one fluid exit lumen in communication with a proximal region of the catheter.

34. The catheter of embodiment 30 wherein the ablation transducer support comprises a recess defined by side edges and a back plate, the recess adapted to receive therein the ultrasound ablation transducer, wherein the ablation transducer is secured within the recess such that the side edges extend radially outward relative to the ablation transducer to allow the free flow of cooling fluid over the ablation transducer.

35. The catheter of embodiment 34 wherein the ablation transducer support is configured to induce turbulent flow of cooling fluid over the ablation transducer.

36. A method in a computer system, comprising:

[0406] receiving as input an ultrasound-based image, the ultrasound-based image derived from signals received from an ultrasound imaging transducer;

[0407] determining the location of an artifact in the ultrasound-based image, the artifact having been created by a fiducial marker on an ultrasound ablation transducer in response to ultrasound waves generated by the ultrasound imaging transducer;

[0408] based on the location of the artifact, determining a direction of aim of ablation energy from the ultrasound ablation transducer; and

[0409] creating an augmented ultrasound-based image as output for display on a monitor, the augmented ultrasound-based image including the ultrasound-based image and the direction of aim of the of ablation energy from the ultrasound ablation transducer.

37. The method of embodiment 36 wherein determining the location of an artifact in the ultrasound-based image comprises recognizing a portion of the ultrasound-based image that substantially does not change shape when the orientation of the ultrasound-based image changes in response to movement of the ultrasound imaging transducer.

38. A computer-implemented method comprising:

[0410] receiving a video or ultrasound-based image of a target ablation site for carotid body ablation created from ultrasound signals transmitted from an ultrasound transceiver, the video or ultrasound-based image having been captured while an ultrasound ablation transducer is located proximate to the target ablation site for carotid body ablation;

[0411] augmenting the video or ultrasound-based image by one or more visual aids, animations or messages, wherein the one or more visual aids, animations or messages include information regarding a direction of aim of ablation energy from the ultrasound ablation transducer for carotid body ablation; and

[0412] displaying the augmented video or ultrasound-based image on a user interface.

39. A computer-implemented method comprising:

[0413] receiving a video or ultrasound-based image of a target ablation site for carotid body ablation created from ultrasound signals transmitted from an ultrasound transceiver, the video or ultrasound-based image having been captured while an ultrasound ablation transducer is located proximate to the target ablation site for carotid body ablation;

[0414] augmenting the video or ultrasound-based image by one or more visual aids, animations or messages, wherein the one or more visual aids, animations or messages include

information regarding an estimated location of an ablation area of an ultrasound ablation transducer being located proximate to the target ablation site for carotid body ablation; and

[0415] displaying the augmented video or ultrasound-based image on a user interface.

40. The computer-implemented method of embodiment 38 wherein the one or more visual aids, animations or messages include information regarding an estimated location of an ablation area of the ultrasound ablation transducer.

41. The computer-implemented method of embodiment 39 or 40 wherein the information regarding an estimated location of an ablation area includes a direction in which the ultrasound ablation transducer is facing and/or a direction in which the ultrasound ablation transducer will deliver ablation energy.

42. The computer-implemented method of embodiment 39, 40 or 41 wherein the information regarding an estimated location of an ablation area includes an estimated depth and/or width of an ablation area of the ultrasound ablation transducer.

43. The computer-implemented method of embodiment 39 or of any of embodiments 40 to 42 wherein the information regarding an estimated location of an ablation area includes an estimated outline of the ablation area.

44. The computer-implemented method of embodiment 39 or of any of embodiments 40 to 43 wherein the information regarding the estimated location of an ablation area of an ultrasound ablation transducer is determined by taking into account user defined and/or automatically set parameters of an ablation procedure.

45. The computer-implemented method of embodiment 39 or of any of embodiments 40 to 44 wherein the estimated location of an ablation area of an ultrasound ablation transducer is determined at least partially based on a selected ablation energy profile.

46. The computer-implemented method of embodiment 39 or of any of embodiments 40 to 45 wherein the estimated location of an ablation area of an ultrasound ablation transducer is determined by taking into account one or more anatomical parameters of a candidate for ablation treatment.

47. The computer-implemented method of embodiment 39 or of any of embodiments 40 to 46 wherein the estimated location of an ablation area of an ultrasound ablation transducer is determined by taking into account information regarding ablation properties of a specific type of catheter carrying the ultrasound ablation transducer.

48. The computer-implemented method of embodiment 47 wherein the information regarding ablation properties of a type of a catheter carrying the ultrasound ablation transducer includes information correlating an estimated lesion depth and/or width with ablation energy and duration for the specific type of catheter.

49. The computer-implemented method of embodiment 39 or any of embodiments 41 to 47 wherein the one or more visual aids, animations or messages further include information regarding a direction of aim of ablation energy from an ultrasound ablation transducer for carotid body ablation.

50. The computer-implemented method of embodiment 38 or 49 wherein the information regarding the direction of aim of ablation energy from the ultrasound ablation transducer for carotid body ablation is determined by using a position of a fiducial marker or an aiming artifact in a video or ultrasound-based image.

51. The computer implemented method of embodiment 50 wherein the fiducial marker is arranged in a predefined position relative to the direction of aim of an ablation catheter carrying the ultrasound ablation transducer.

52. The computer-implemented method of embodiment 51 wherein the fiducial marker includes a band or tube having distinctly hyperechoic or hypoechoic material or structure compared to surrounding structures and/or surrounding tissue when located proximate to the target ablation site.

53. The computer-implemented method of embodiment 50 or 51 wherein the fiducial marker includes a piezoelectric element.

54. The computer-implemented method of embodiment 50 wherein the aiming artifact is positioned on an ablation catheter carrying the ultrasound ablation transducer to indicate on an ultrasound-based image the opposite direction of delivery of ablation energy.

55. The computer-implemented method of embodiment 50 wherein the information regarding the direction of aim of ablation energy from the ultrasound ablation transducer for carotid body ablation is determined by using a position of multiple fiducial markers or an aiming artifacts in a video or ultrasound-based image.

56. The computer implemented method of any one of embodiments 39 and 40 to 55 wherein the video or ultrasound-based image was created with an ultrasound imaging catheter.

57. The computer implemented method of embodiment 56 wherein the ultrasound imaging catheter was placed in a jugular vein of a candidate for carotid body ablation in proximity to a carotid bifurcation.

58. The computer implemented method of any one of embodiments 39 and 40 to 57, further comprising:

[0416] determining a scale of the video or ultrasound-based image based of a known dimension of a catheter or aiming artifact visible in the video or ultrasound-based image.

59. The computer implemented method of any one of embodiments 39 and 40 to 58 wherein the one or more visual aids, animations or messages include information of one or more distances between anatomical features of the target ablation site.

60. The computer implemented method of embodiment 59 wherein the one or more distances include one or more of a relative position of an internal jugular vein, a carotid septum, an internal carotid artery, an external carotid artery, or carotid septum boundaries to a reference point, artery diameters, changes in artery diameters, changes in relative position of anatomical features, size and relative position of an estimated ablation or created ablation.

61. The computer implemented method of any one of embodiments 59 and 60 further comprising providing a user with ablation therapy instructions or suggestions based on the one or more distances between anatomical features of the target ablation site.

62. A computer system for monitoring a carotid ablation procedure being configured to perform the operations of any one of embodiments 38, 39 and 40 to 61.

63. The computer system of embodiment 62 comprising a display configured to display the augmented video or ultrasound-based image and an input interface configured for receiving the video or ultrasound-based image from an ultrasound imaging device.

64. A computer readable medium including instructions which when executed by a computer system let the computer system carry out the operations of any one of embodiments 38, 39 and 40 to 61.

65. A system for imaging and ablation of a carotid body having image augmentation comprising:

[0417] a catheter with an ultrasound imaging transducer and an ablation element;

[0418] an ablation console;

[0419] an ultrasound imaging console configured for transmitting and receiving signals to and from the imaging transducer;

[0420] a computer executed algorithm that creates an ultrasound-based image from signals received from the imaging transducer;

[0421] an image augmentation unit that processes the ultrasound-based image with a computer algorithm that creates an augmented image; and

[0422] a monitor to display the augmented image.

66. A system of embodiment 65 wherein the augmented image is overlaid on the ultrasound-based image and indicates the direction of delivery of ablation energy, carotid arteries, an estimated ablation outline, estimated ablation depth, and estimated created ablation positions.

67. A system of embodiment 65 wherein the computer algorithm controls the ablation console using calculations of relative positions of estimated ablation position and carotid arteries.

68. A computer implemented method for determining parameters for a carotid body ablation procedure, the method comprising:

[0423] receiving information characterizing a dimension of a desired ablation volume of an ultrasound carotid body ablation procedure; and

[0424] automatically determining one or more ultrasound ablation delivery parameters based on the received information; and

providing as output to an ultrasound ablation delivery system the delivery parameters.

69. The computer implemented method of embodiment 68 wherein the one or more ultrasound ablation delivery parameters include an ablation energy profile to be used by the ablation delivery system.

70. The computer implemented method of embodiment 69 wherein an ablation energy profile specifies a profile of an amount of acoustic power and duration of delivery of the ablation energy during a treatment procedure.

71. The computer implemented method of embodiment 68 or 70 wherein the one or more ultrasound ablation delivery parameters are determined by taking into account one or more anatomical parameters of a candidate for ablation treatment.

72. The computer-implemented method of embodiment of any of embodiments 68 to 71 wherein the one or more ultrasound ablation delivery parameters are determined by taking into account information regarding ablation transducer properties of a specific catheter carrying the ultrasound ablation transducer.

73. The computer-implemented method of embodiment 72 wherein the information regarding ablation transducer properties of a catheter carrying the ultrasound ablation transducer includes information correlating an estimated lesion depth and/or width with electrical power and duration for the specific ablation catheter.

74. The computer implemented method of any one of embodiments 68 to 73, wherein the desired ablation volume of an ultrasound carotid body ablation procedure is automatically determined based on a video or ultrasound-based image created from ultrasound signals transmitted from an ultrasound transducer of a target ablation site for carotid body ablation.

75. The computer implemented method of embodiment 74 wherein the automatic determination includes assessing position or size of one or more anatomic features in the target ablation site.

76. The computer implemented method of embodiment 75 wherein the one or more anatomic features include a carotid septum, a carotid body, internal and external carotid arteries and a jugular vein.

77. The computer implemented method of any one of the embodiments 68 and 69 to 76 wherein automatically determining one or more ultrasound ablation delivery parameters includes using information retrieved from prior ablation procedures and/or evaluation of numerical models of simulation procedures.

78. The computer implemented method of any one of the embodiments 68 and 69 to 76 further comprising:

[0425] automatically monitoring a movement of a patient's body or head;

[0426] identifying a movement that meets a predetermined significance criterion indicating a risk for the patient; and

[0427] generating a signal indicating that a movement has met a predetermined significance criterion.

79. A computer system for monitoring a carotid ablation procedure being configured to perform the operations of any one of embodiments 82, 68 and 69 to 78.

80. A computer readable medium including instructions which when executed by a computer system let the computer system carry out the operations of any one of embodiments 82, 68 and 69 to 78.

81. The computer implemented method of embodiment 68 wherein the one or more ultrasound ablation delivery parameters include duration of energy delivery and acoustic power wherein the acoustic power is in a range between 2 watts and 25 watts and the duration is in a range between 5 seconds and 25 seconds.

82. A method in a computer system, comprising:

[0428] receiving as input a distance, measured from an ultrasound-based image derived from a signal received from an ultrasound transducer positioned in a jugular vein, from a wall of a jugular vein to a line connecting portions of an internal and external carotid arteries;

[0429] determining ultrasound ablation delivery parameters based on the input distance; providing as output to an ultrasound ablation delivery system the delivery parameters.

83. An ultrasound catheter adapted to be used to image and ablate tissue, comprising: a deflectable section proximal to an imaging and ablation section.

84. The catheter of embodiment 83 further comprising a plurality of deflectable sections, any of which can optionally deflect in different planes.

85. The catheter of embodiment 83 wherein the catheter includes an ultrasound ablation transducer, and the deflectable section is adapted to deflect in a plane aligned with a direction of aim of the ablation transducer.

86. The catheter of embodiment 83 wherein the catheter includes an imaging and ablation section, and the catheter is

adapted such that a position of the imaging and ablation section relative to the deflectable position can be modified.

87. The catheter of embodiment 86 wherein the position of the imaging and ablation section can be telescopically modified relative to the deflectable section and/or rotationally modified relative to the deflectable section.

88. The catheter or embodiment 86 wherein the catheter further comprises a locking mechanism to maintain the relative positions of the imaging and ablation section and the deflectable sections.

89. An ultrasound catheter configured to deflect at a variety of distances from an imaging and ablation section of the catheter.

90. An ultrasound catheter adapted to be used to image and ablate tissue, comprising:

[0430] an elongate member, optionally including an elongate tube, comprising an imaging and ablation region at or near its distal end; and

[0431] an integrated sheath integrated with the elongate member, the integrated sheath extending around a portion of the elongate member.

91. The catheter of embodiment 90 wherein the elongate member is adapted to be at least one of rotated and axially movable relative to the integrated sheath.

92. The catheter of embodiment 90 wherein the integrated sheath includes a lumen along at least a portion of its length in which the elongate member extends.

93. The catheter of embodiment 92 wherein a width (such as a diameter) of a distal region of the elongate member, optionally including the imaging and ablation section, is greater than a diameter of the lumen.

94. An ultrasound catheter adapted to be used to image and ablate tissue, comprising:

[0432] an imaging and ultrasound ablation section at or near a distal end of the catheter; and a movable protection mechanism associated with the imaging and ultrasound ablation section.

95. The catheter of embodiment 94 wherein the movable protection mechanism is adapted to be at least one of moved and changed in configuration with respect to the imaging and ultrasound ablation section.

96. The catheter of embodiment 94 wherein the movable protection mechanism has an undeployed state or configuration for delivery and a deployed state or configuration for ablation.

97. The catheter of embodiment 94 wherein the movable protection mechanism is adapted to be moved axially relative to the imaging and ultrasound ablation section.

98. The catheter of embodiment 94 wherein the movable protection mechanism is adapted to be moved out of an ablation energy path for ablation.

99. The catheter of embodiment 94 wherein the movable protection mechanism is adapted to change configuration for ablation.

100. The catheter of embodiment 98 wherein the movable protection mechanism includes at least one spline at least a portion of which is adapted to become more bent in an ablation configuration compared to a delivery configuration.

101. The catheter of embodiment 100 wherein the movable protection mechanism includes at least two splines coupled to a membrane material that at least partially defines an imaging and ablation chamber of the catheter.

102. The catheter of embodiment 101 wherein the membrane is adapted to at least one of unfold or stretch as the splines are moved from the delivery configuration to the ablation configuration.

103. The catheter of embodiment 94 wherein the movable protection mechanism is adapted to be moved by an actuator, the actuator optionally a part of a handle.

104. The catheter of embodiment 103 wherein the movable protection mechanism is adapted to be moved by actuation with the use of pull wire in operable connection with the actuator and the movable protection mechanism.

105. An ultrasound catheter adapted to be used to image and ablate tissue adapted to intentionally allow a coolant to exit the catheter into the surrounding environment.

106. The catheter of embodiment 105 wherein the catheter is adapted to intentionally allow a coolant to exit a working distal region of the catheter into the surrounding environment.

107. A method of using an ultrasound catheter in a patient, comprising delivering saline coolant through the catheter and out of the catheter into the patient.

108. An ultrasound catheter adapted to be used to image and ablate tissue, comprising:

[0433] an ultrasound ablation transducer, at least a portion of which is electrically insulated from a coolant, such as saline coolant.

109. The catheter of embodiment 108 wherein at least a portion of the ultrasound ablation transducer is coated with an electrical insulator, optionally sides and/or back of the ultrasound ablation transducer.

110. The catheter of embodiment 108 wherein the at least a portion of the ultrasound ablation transducer is electrically insulated from a cooling fluid by being mounted to a backing and not in communication with the coolant.

110. The catheter of embodiment 108 wherein at least one component in electrical communication with the ultrasound ablation transducer is electrically insulated from the coolant.

111. A method of manufacturing an ultrasound ablation transducer, comprising masking a portion of the ultrasound ablation transducer; applying an insulation material to the ultrasound ablation transducer; and removing the mask.

112. An ultrasound ablation catheter wherein an ultrasound ablation transducer is mounted to or embedded in a flexible circuit or circuit board.

113. An ultrasound ablation catheter comprising an ultrasound ablation transducer and a coolant flow path, wherein the catheter is configured so that only a portion of the ultrasound ablation transducer is exposed to coolant.

114. The catheter of embodiment 113 wherein the ultrasound ablation transducer is disposed within an ablation transducer support recess configured to prevent coolant from being exposed to at least one of the sides and back of the ultrasound ablation transducer.

115. An ultrasound ablation catheter comprising an ultrasound ablation transducer, a first coolant flow path, and a second coolant flow path, the first and second coolant flow paths being physically separated from one another.

116. The ultrasound ablation catheter of embodiment 115, wherein a front side of the ultrasound ablation transducer is exposed to the first coolant flow path (but not the second coolant flow path), and a back side of the transducer or the back of an ablation transducer support to which the ablation transducer is mounted is exposed to the second flow path (but not the first coolant flow path).

117. The ultrasound ablation catheter of embodiment 115 wherein the ultrasound ablation transducer is mounted to a ablation transducer support.

118. The ultrasound ablation catheter of embodiment 115 further comprising a first coolant source in fluid communication with the first coolant flow path, and a second coolant source in fluid communication with the second coolant flow path, the two fluid sources not in fluid communication.

119. The ultrasound catheter of embodiment 115 wherein the first and second coolant flow paths are in a distal region of the catheter that includes the ultrasound ablation transducer.

120. The ultrasound catheter of embodiment 115 wherein the first and second coolant flow paths are in a region of the catheter proximal to a distal region that includes the ultrasound ablation transducer.

121. The ultrasound catheter of embodiment 115 further comprising first and second fluid exits that are not in fluid communication.

122. An ultrasound ablation catheter comprising an ultrasound ablation transducer, the catheter not including a chamber housing around the ultrasound ablation transducer that prevents blood from interfacing the ablation transducer.

123. An ultrasound ablation catheter comprising an ultrasound ablation transducer, the catheter configured to expose the ablation transducer to ambient surroundings, such as blood, at least when a coolant is not being delivered towards the ablation transducer.

124. An ultrasound ablation catheter comprising an ultrasound ablation transducer, the catheter not including a membrane or balloon that defines a chamber around the ablation transducer.

What is claimed is:

1. An ultrasound ablation catheter, comprising:
an ultrasound ablation transducer axially spaced from,
and with a fixed position relative to, an ultrasound
imaging transducer.
2. The catheter of claim 1 further comprising an insulating
member engaging at least one surface of the ablation trans-
ducer, the insulating member electrically isolating at least
one pole of the ablation transducer from conductive fluid in
the echolucent chamber.
3. The catheter of claim 2 wherein the insulating member
is in contact with first and second sides of the ablation
transducer.
4. The catheter of claim 3 wherein the insulating member
is not disposed on the face of the ablation transducer.
5. The catheter of any one of claims 2 to 4, wherein the
echolucent chamber comprises a cooling fluid inlet port
proximal to the ablation transducer and a cooling fluid exit
port distal to the ablation transducer.
6. The catheter of claim 5, wherein the cooling fluid exit
port is positioned to allow the flow of cooling fluid to a
location outside of the catheter.
7. The catheter of any one of claims 2 to 6, wherein the
insulating member has a thickness of 10 to 30 microns, 10
to 25 microns, 20 to 25 microns or 22 microns.
8. The catheter of any one of the preceding claims,
wherein the echolucent chamber includes a membrane.
9. The catheter of claim 8, wherein the echolucent cham-
ber further includes an ablation transducer support.
10. The catheter of claim 9, wherein the ablation trans-
ducer support comprises a cavity formed therein.
11. The catheter of claim 9 or claim 10 wherein the
membrane extends over an outer surface of the ablation

transducer support at least one of proximal and distal ends
of the ablation transducer support.

12. The catheter of any one of claims 9 to 11, wherein the
ultrasound ablation transducer is secured, directly or indi-
rectly, to a flat surface of the ablation transducer support.

13. The catheter of any one of claims 8 to 12 wherein the
membrane is arranged so that the echolucent chamber sub-
stantially conforms to an outer surface of the catheter
proximal and distal to the echolucent chamber.

14. The catheter of any of claims 8-13, wherein the
echolucent chamber does not extend past a cross-sectional
extension of the catheter proximal and distal to the echolu-
cent chamber.

15. The catheter of any of claims 8-14, wherein the
membrane has a configuration that generally follows the
configuration of at least a portion of an outer surface of the
catheter proximal and distal to the echolucent chamber.

16. The catheter of any of claims 8-15, wherein the
membrane is not adapted to be expanded radially outward
when the echolucent chamber is filled with fluid.

17. The catheter of any of claim 8-16, wherein the
membrane has a generally fixed configuration.

18. The catheter of any of claims 8-17, wherein the
thickness of the membrane is between 0.0002" and 0.009".

19. The catheter of any one of the preceding claims,
wherein the ultrasound imaging transducer comprises a
plurality of ultrasound imaging transducers disposed at least
partly around the circumference of the catheter.

20. The catheter of claim 19, wherein the plurality of
ultrasound imaging transducers include three or more ultra-
sound imaging transducers.

21. The catheter of claim 19 or claim 20, wherein the
plurality of ultrasound imaging transducers are configured to
generate an image that represents a portion of greater than
75% or greater than 85% of a transection of tissue around the
catheter.

22. The catheter of any one of claims 19 to 21, wherein
the plurality of ultrasound imaging transducers do not
extend all the way around the circumference of the catheter,
and wherein a distance between first and second imaging
transducers at a location on the circumference that is oppo-
site a direction of aim of the ultrasound ablation transducer
is greater than a distance between the first imaging trans-
ducer and a third imaging transducer adjacent to the first
imaging transducer.

23. The catheter of any one of claims 19 to 21 wherein the
plurality of ultrasound imaging transducers extend all of the
way around the circumference of the catheter, with a gap
between each of the adjacent imaging transducers.

24. The catheter of any one of claims 19-23 wherein at
least one of the plurality of ultrasound imaging transducers
is adapted to be individually activated and deactivated.

25. The catheter of claim 23, wherein the gaps have the
same width.

26. The catheter of any one of claims 19 to 25, wherein
the plurality of ultrasound imaging transducers are disposed
such that centers of each of the plurality of ultrasound
imaging transducers are disposed in a plane, the plane
transverse to a longitudinal axis of the catheter.

27. The catheter of any one of the preceding claims,
wherein the echolucent chamber comprises a recessed
region within the cross-section of the ultrasound ablation
catheter.

28. The catheter of claim 27, wherein the ultrasound ablation transducer is arranged within the recessed region.

29. The catheter of claim 27 or claim 28, wherein the ultrasound imaging transducer is not arranged within the recessed region.

30. The catheter of any one of the preceding claims, wherein the ultrasound imaging transducer is carried by an external catheter shaft surface.

31. The catheter of any one of the preceding claims, wherein the ultrasound ablation transducer is disposed near or overlapping a central axis of the catheter, optionally within 1 mm from the central axis of the catheter in a radial direction of the catheter.

32. The catheter of any one of the preceding claims, wherein the ultrasound imaging transducer or the plurality of ultrasound imaging transducers is proximal relative to the ultrasound ablation transducer.

33. The catheter of any one of the preceding claims, further comprising a guidewire lumen disposed behind the ablation transducer, opposite the direction of aim of the ablation transducer.

34. The catheter of claim 33, wherein the guidewire lumen is not co-axial with a catheter longitudinal axis along the length of the ablation transducer.

35. The catheter of claim 33 or claim 34, wherein the guidewire lumen, where it extends along and behind the ablation transducer, is not in general alignment with the guidewire lumen at locations proximal to and distal to the ablation transducer.

36. The catheter of any one of claim 33 to claim 35, wherein the guidewire lumen extends along a center of the catheter in a region of an end cap of the catheter.

37. The catheter of any one of the preceding claims, wherein the ablation transducer has a width, and the catheter has a catheter diameter, wherein the ratio of the catheter diameter to the width is no more than 2.5.

38. The catheter of any one of the preceding claims, further comprising a radiopaque marker overlapping the imaging transducer, in a side view.

39. The catheter of claim 38, wherein the radiopaque marker is disposed at the level of the imaging plane of the imaging transducer.

40. The catheter of claim 38 or claim 39, further comprising a sheath in which the catheter is disposed, the sheath comprising a sheath radiopaque marker on a distal region.

41. The catheter of claim 40, wherein the sheath radiopaque marker is a first axial distance from the radiopaque marker, and the radiopaque marker is a second axial distance from the center of the ablation transducer, the

first and second distances being substantially the same, optionally wherein one of the distances is within 10% of the other distance.

42. The catheter of any one of claims 38 to 41, wherein an axial distance from the center of the radiopaque marker to an axial center of the ablation transducer is between 4 mm and 12 mm.

43. The catheter of any one of claims 38 to 42, further comprising a radiopaque cap on a distal region of the catheter.

44. The catheter of any one of the preceding claims, wherein the imaging transducer or the plurality of transducers is configured to generate an image of a plane of tissue that is about 1 to 15 mm, optionally about 3 to 12 mm from a center of the transmitting face of the ablation transducer.

45. The catheter of any one of claims 1 to 39 wherein the catheter is adapted such that it can be delivered without the use of a delivery sheath, the catheter further comprising a deflectable section proximal to the ultrasound imaging transducer and the ultrasound ablation transducer.

46. The catheter of claim 45 wherein the deflectable section is deflectable in at least 2 directions.

47. The catheter of claim 45 or claim 46 wherein the catheter has a plurality of deflectable sections, axially spaced, that are adapted to be individually controlled.

48. The catheter of any one of claims 45 to 47 further comprising a passively deflectable section between the deflectable section and a section that includes the two ultrasound transducers.

49. The catheter of any one of the preceding claims further comprising circuitry being configured to collect data regarding the use of the catheter or one of its components and to provide an interface for an external device to interrogate the collected data.

50. The catheter of claim 49 wherein the collected data includes one or more of data indicating whether or not the catheter or one of its components has ever been used before, data indicating a duration of use of the catheter or one of its components and an indication of whether or not a predetermined duration of time has passed since the last use or initial use of the catheter or one of its components.

51. The catheter of claim 49 or claim 50 wherein the circuitry being configured to collect data regarding the use of the catheter or one of its components includes a timing circuit.

52. The catheter of any one of claims 49 to 51 wherein the catheter is disposable or includes one or more disposable components.

* * * * *

专利名称(译)	颈动脉体消融用经静脉超声成像和消融导管		
公开(公告)号	US20160374710A1	公开(公告)日	2016-12-29
申请号	US15/263174	申请日	2016-09-12
[标]申请(专利权)人(译)	SINELNIKOV叶戈尔D 恩格尔曼琐珥JACOB MARK盖尔芬德 GRASSE MARTIN中号 KOSS一个TIMOTHY MARKHAM MICHAEL BRICK MARTIN KENNETH中号 SUORSA VEIJOt TAIMISTO仪^ h DE LA MENARDIERE BRICE ARNAULT 鲍德温克莱顿英里 MILLER JASON		
申请(专利权)人(译)	SINELNIKOV, 叶戈尔D. 恩格尔曼, 琐珥JACOB 盖尔芬德, MARK 格拉斯MARTIN M. KOSS, TIMOTHY A. MARKHAM, MICHAEL砖 MARTIN, KENNETH M. SUORSA, VEIJO T. TAIMISTO, MIRIAM H. 魏, 西安 DE LA MENARDIERE, BRICE ARNAULT 鲍德温, CLAYTON MILES MILLER, JASON		
当前申请(专利权)人(译)	SINELNIKOV, 叶戈尔D. 恩格尔曼, 琐珥JACOB 盖尔芬德, MARK 格拉斯MARTIN M. KOSS, TIMOTHY A. MARKHAM, MICHAEL砖 MARTIN, KENNETH M. SUORSA, VEIJO T. TAIMISTO, MIRIAM H. 魏, 西安 DE LA MENARDIERE, BRICE ARNAULT 鲍德温, CLAYTON MILES MILLER, JASON		
[标]发明人	SINELNIKOV YEGOR D ENGELMAN ZOAR JACOB GELFAND MARK GRASSE MARTIN M KOSS TIMOTHY A MARKHAM MICHAEL BRICK MARTIN KENNETH M SUORSA VEIJO T		

TAIMISTO MIRIAM H
WEI XIAN
DE LA MENARDIERE BRICE ARNAULT
BALDWIN CLAYTON MILES
MILLER JASON

发明人
SINELNIKOV, YEGOR D.
ENGELMAN, ZOAR JACOB
GELFAND, MARK
GRASSE, MARTIN M.
KOSS, TIMOTHY A.
MARKHAM, MICHAEL BRICK
MARTIN, KENNETH M.
SUORSA, VEIJO T.
TAIMISTO, MIRIAM H.
WEI, XIAN
DE LA MENARDIERE, BRICE ARNAULT
BALDWIN, CLAYTON MILES
MILLER, JASON

IPC分类号 A61B17/32 A61B17/3207 A61B8/08 A61B8/12 A61B8/00

CPC分类号 A61B17/320068 A61B8/12 A61B8/445 A61B8/481 A61N2007/0052 A61B2017/0023 A61B2017/00296 A61B2017/22028 A61B2017/320084 A61B17/3207 A61B8/0891 A61B17/2202 A61B17/3478 A61B18/1492 A61B18/24 A61B2017/00256 A61B2017/003 A61B2017/22024 A61B2017/22058 A61B2017/22062 A61B2017/22069 A61B2017/320044 A61B2017/320069 A61B2017/320071 A61B2018/00023 A61B2018/00404 A61B2018/00577 A61B2018/1425 A61B2018/1475 A61B2034/2063 A61B2034/2065 A61B2090/3782 A61B2090/3784 A61N7/022 A61B8/54 A61B2017/00106 A61B2017/00225 A61B2217/007 A61M25/09

优先权
62/132459 2015-03-12 US
61/952015 2014-03-12 US
62/017148 2014-06-25 US
62/049980 2014-09-12 US
62/217570 2015-09-11 US
62/219595 2015-09-16 US

外部链接 [Espacenet](#) [USPTO](#)

摘要(译)

用于评估和治疗患有交感神经介导的疾病的患者的方法和装置，其涉及通过经由颈动脉体消融减少对神经系统的化学传感器输入而增加的外周化学反射和增强的交感紧张。可以使用超声消融导管来执行所述方法。所述方法还可包括使用至少一个超声成像导管进行成像。

