



(19) **United States**

(12) **Patent Application Publication**  
**Browning et al.**

(10) **Pub. No.: US 2010/0160779 A1**  
(43) **Pub. Date: Jun. 24, 2010**

(54) **ULTRASOUND SYSTEM FOR CEREBRAL BLOOD FLOW IMAGING AND MICROBUBBLE-ENHANCED BLOOD CLOT LYSIS**

**Related U.S. Application Data**

(60) Provisional application No. 60/822,106, filed on Aug. 11, 2006.

(75) Inventors: **Theodore J. Browning**, Lake Forest Park, WA (US); **William Shi**, Briarcliff Manor, NY (US); **Jeffrey E. Powers**, Bainbridge Island, WA (US); **Michalakis Averkiou**, Nicosia (CY); **Thomas Gauthier**, Seattle, WA (US)

**Publication Classification**

(51) **Int. Cl.**  
*A61N 7/00* (2006.01)  
*A61B 8/06* (2006.01)  
(52) **U.S. Cl.** ..... **600/439; 600/454**

Correspondence Address:  
**K&L Gates LLP**  
**P.O. BOX 1135**  
**CHICAGO, IL 60690 (US)**

(73) Assignee: **Koninklijke Philips Electronics N.V.**, Eindhoven (NL)

(21) Appl. No.: **12/376,317**

(22) PCT Filed: **Aug. 3, 2007**

(86) PCT No.: **PCT/IB07/53073**

§ 371 (c)(1),  
(2), (4) Date: **Feb. 4, 2009**

(57) **ABSTRACT**

An ultrasonic diagnostic imaging system is described which utilizes one or more transducer arrays affixed to the head of a patient to diagnose and treat stroke victims. The transducer headset produces a two or three dimensional image of the vasculature inside the cranium, preferably assisted by a microbubble contrast agent. A vascular flow map is produced by the system which may be diagnosed for signs of a blood clot. If a blood clot is detected, a therapeutic beam is transmitted while the contrast agent is present to break up the blood clot by the disruption of microbubbles. The headset may also be used in a monitoring application to detect the recurrence of blood clots in a stroke victim.

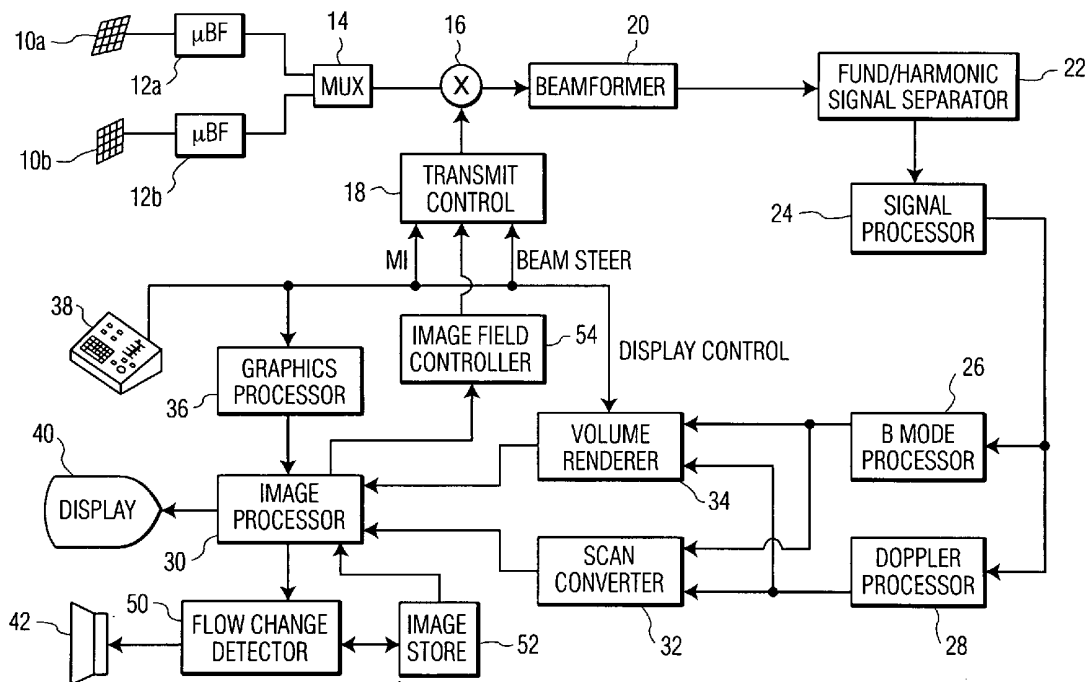

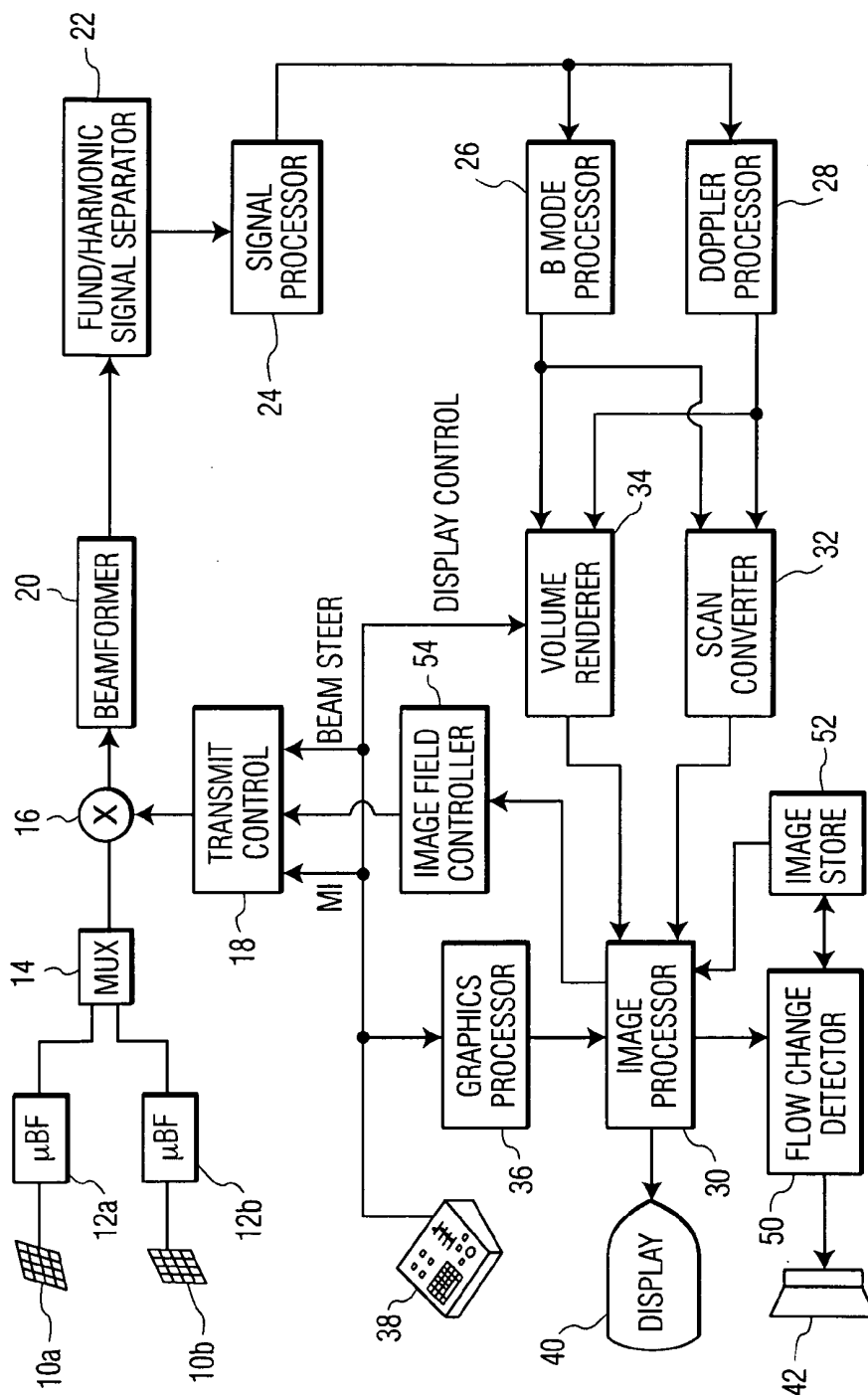

FIG. 1

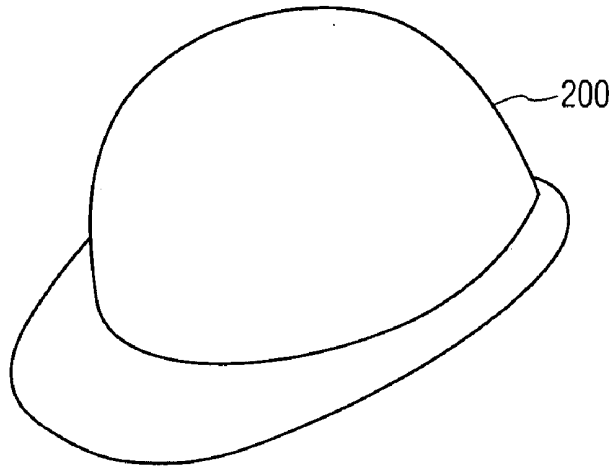

FIG. 2A

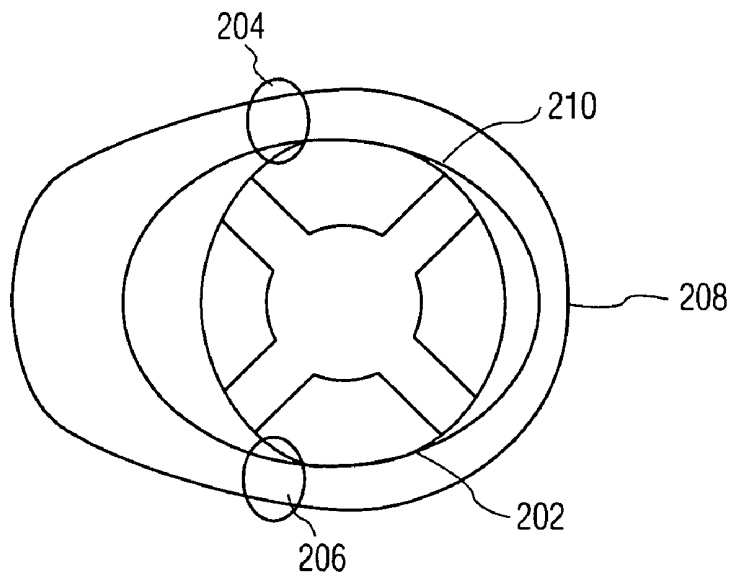

FIG. 2B

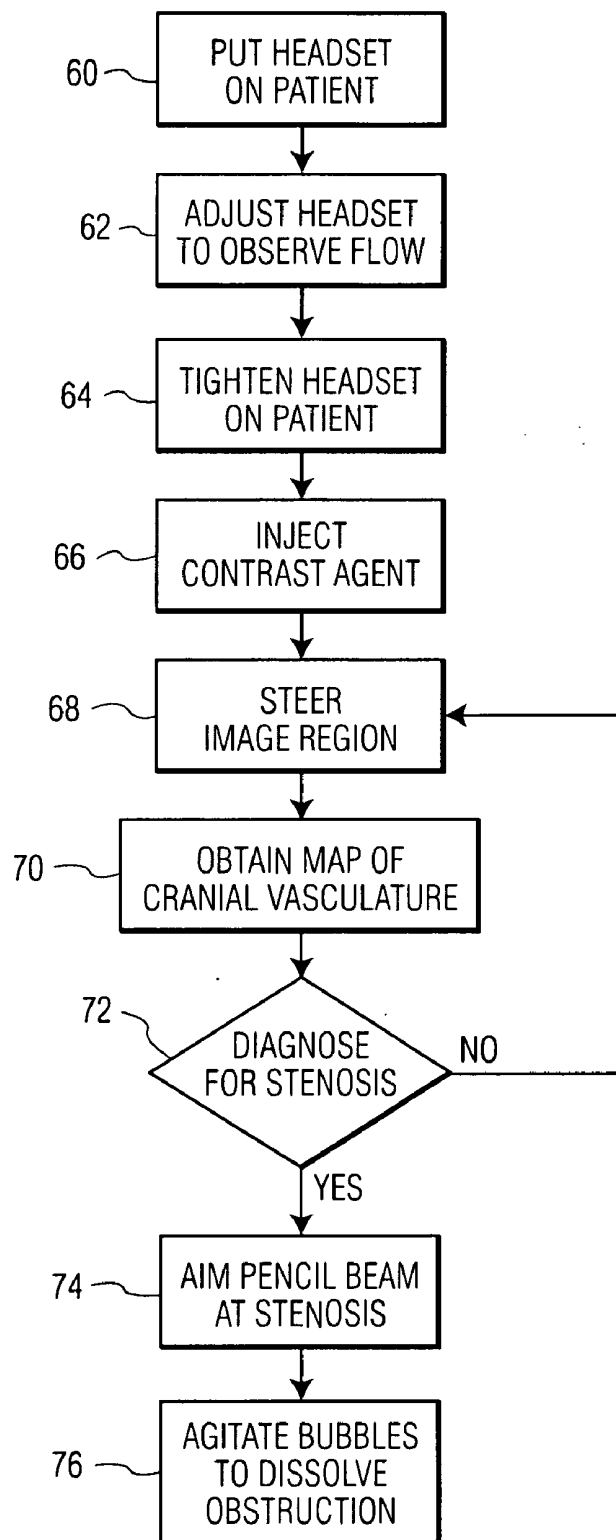

FIG. 3

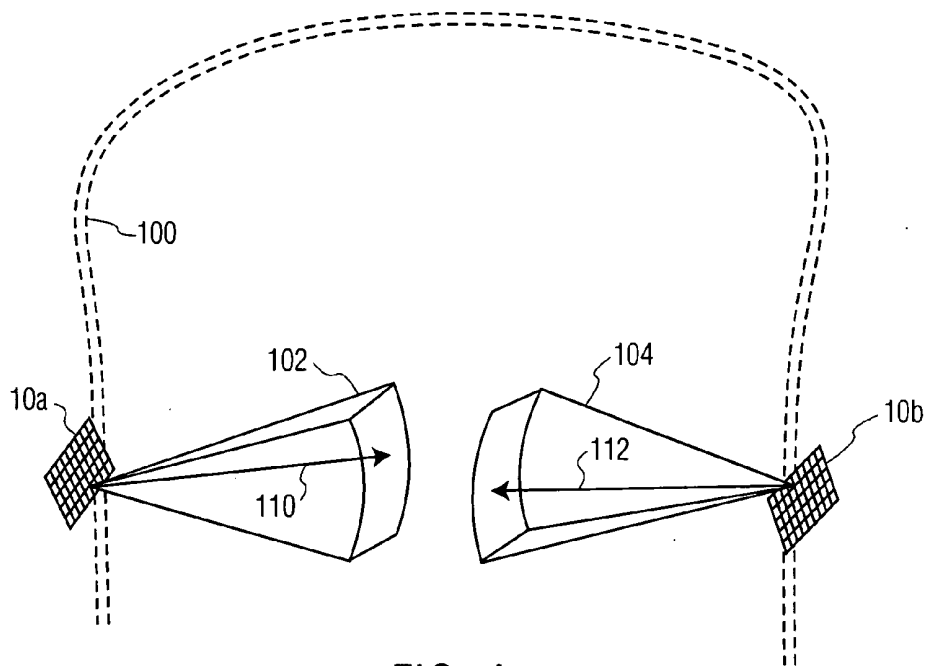

FIG. 4

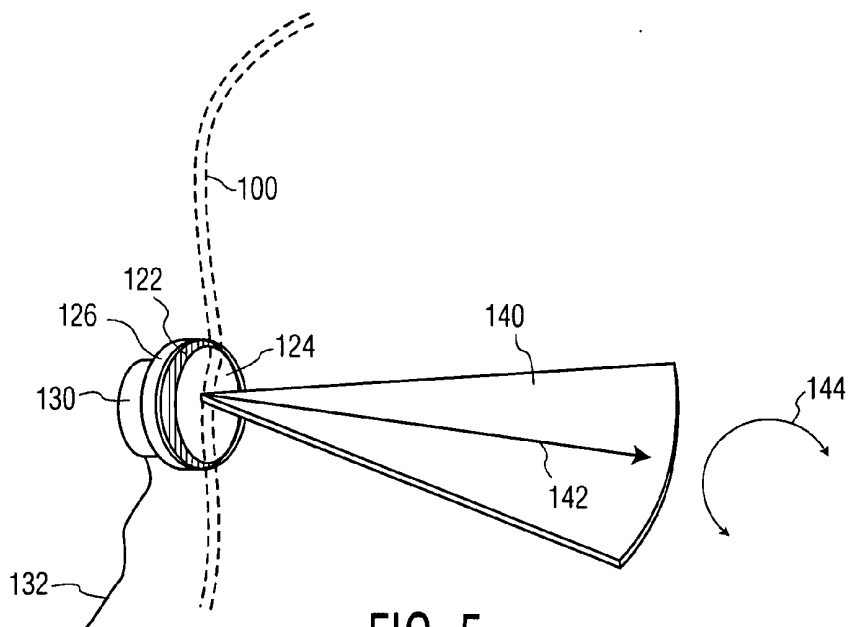

FIG. 5

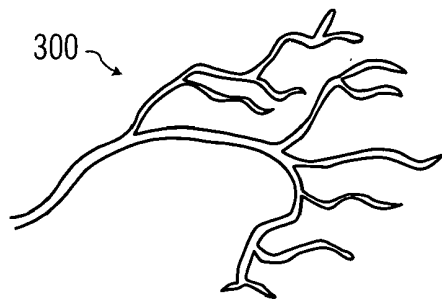

FIG. 6A

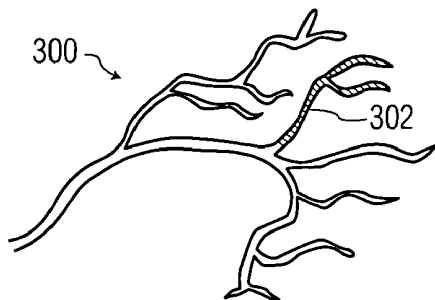

FIG. 6B

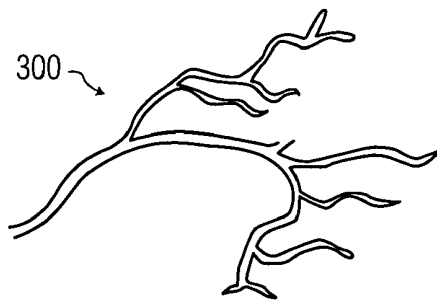

FIG. 6C

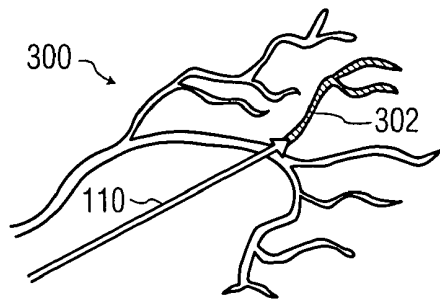

FIG. 6D

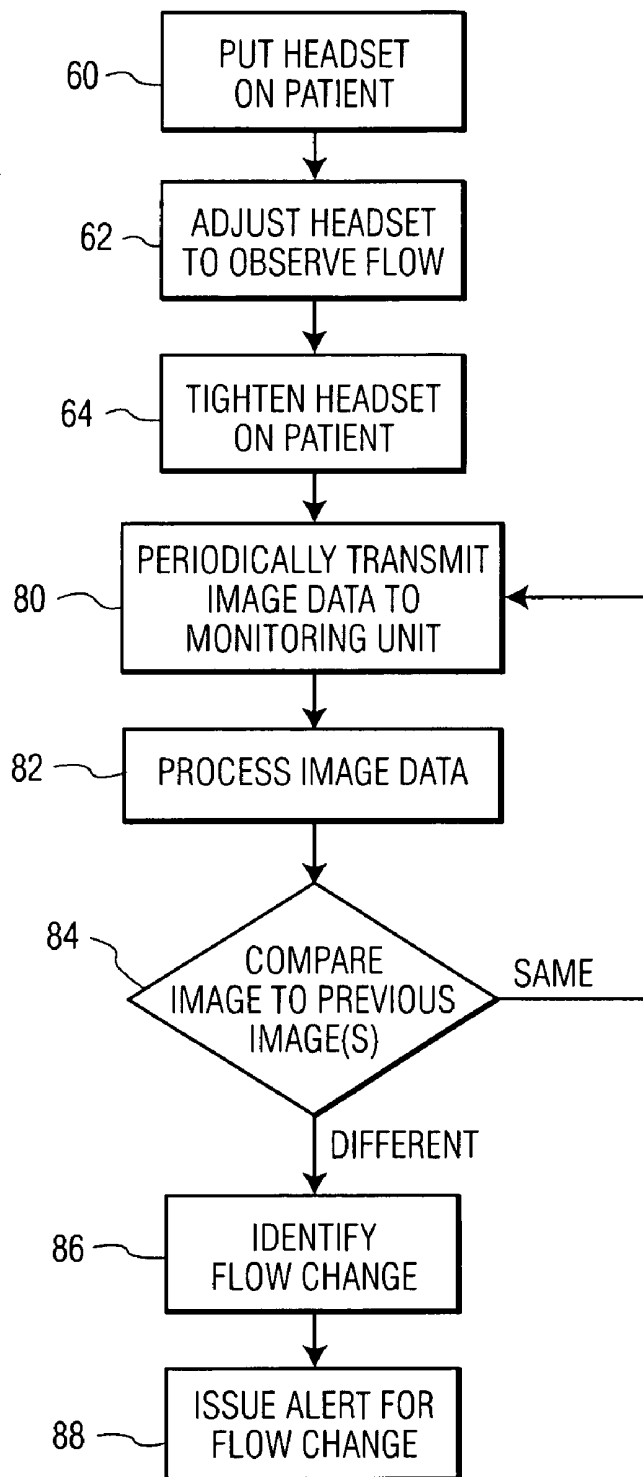

FIG. 7

**ULTRASOUND SYSTEM FOR CEREBRAL  
BLOOD FLOW IMAGING AND  
MICROBUBBLE-ENHANCED BLOOD CLOT  
LYSIS**

[0001] This invention relates to medical diagnostic ultrasound systems and, in particular, to ultrasound systems which perform imaging and therapy for stroke victims.

[0002] Ischemic stroke is one of the most debilitating disorders known to medicine. The blockage of the flow of blood to the brain can rapidly result in paralysis or death. Attempts to achieve recanalization through thrombolytic drug therapy such as treatment with tissue plasminogen activator (tPA) has been reported to cause symptomatic intracerebral hemorrhage in a number of cases. Advances in the diagnosis and treatment of this crippling affliction are the subject of continuing medical research.

[0003] Transcranial Doppler ultrasound has been developed for use in monitoring and diagnosing stroke. A headset device manufactured by Spencer Technologies of Seattle, Wash., USA holds two transducers against the side of the skull, one on each temporal bone just in front of the ear. The transducers transmit ultrasonic waves through the temporal bone and the returning echo signals are Doppler processed and the phase shift information reproduced at audible frequencies. The audible Doppler identifies the presence or absence of blood flow inside the cranium as the clinician listens for characteristic sounds of blood flow velocities of specific arteries. The technique can also be augmented with a spectral Doppler display of the phase shift information, providing information on flow velocities inside the cranium. However, since there is no information concerning the anatomy inside the skull, the clinician must attempt to make a diagnosis on the basis of this limited information. This diagnostic approach is also very technique-dependent and is performed by highly trained individuals.

[0004] Recently Dr. Andrei Alexandrov of the University of Texas Medical School at Houston, Tex. found that the application of ultrasound during tPA treatment improved the efficacy of tPA for stroke treatment. Dr. Alexandrov observed that the micro-vibrations of the ultrasonic waves work on the surface of the blood clot to open up a larger surface that the tPA can then bind to and penetrate. Dr. Alexandrov is now leading a research team which is investigating the added efficacy of adding ultrasonic contrast agent microbubbles to the tPA or using microbubbles and ultrasound alone to dissolve blood clots. It is also contemplated that microbubbles may be targeted to components in the blood clot such as fibrin and stick to the clot, increasing the concentration and effectiveness of the treatment. Targeted nanoparticles are another possibility for this procedure. It is thus believed by many that ultrasound together with thrombolytic drugs, microbubbles, or both can lead to significant improvement in stroke treatment.

[0005] In accordance with the principles of the present invention, a diagnostic ultrasound system and method are described which enable a clinician to transcranially visualize a region of the cerebral vasculature where blood clots may be present. Either two dimensional or three dimensional imaging may be employed. The imaging of the vasculature is preferably enhanced by the administration of microbubbles. If the flow conditions of the vasculature indicate the presence of a partial or complete occlusion, a focused or pencil beam is

directed to the location of the blockage to break up the clot by the vibrations and/or rupturing of the microbubbles. In some instances the ruptured microbubbles may also release an encapsulated thrombolytic drug. In accordance with a further aspect of the present invention, the cranial vasculature may be monitored by ultrasonic imaging for changes which are indicative of the recurrence of an occlusion, and medical aid alerted to the condition.

[0006] In the drawings:

[0007] FIG. 1 illustrates in block diagram form an ultrasonic diagnostic imaging system constructed in accordance with the principles of the present invention.

[0008] FIGS. 2a and 2b illustrate a safety helmet liner suitable for use in a transcranial imaging transducer headset.

[0009] FIG. 3 illustrates a procedure for ultrasonically imaging the cranial vasculature and dissolving blood clots in accordance with the principles of the present invention.

[0010] FIG. 4 illustrates three dimensional transcranial imaging in accordance with the present invention.

[0011] FIG. 5 illustrates two dimensional transcranial imaging in accordance with the present invention.

[0012] FIGS. 6a-6d illustrate treatment of a cranial occlusion in accordance with the principles of the present invention.

[0013] FIG. 7 illustrates a procedure for ultrasonically monitoring for cranial occlusions in accordance with the present invention.

[0014] Referring first to FIG. 1, an ultrasound system constructed in accordance with the principles of the present invention is shown in block diagram form. Two transducer arrays 10a and 10b are provided for transmitting ultrasonic waves and receiving echo information. In this example the arrays shown are two dimensional arrays of transducer elements capable of providing 3D image information although an implementation of the present invention may also use two dimensional arrays of transducer element which produce 2D (planar) images. The transducer arrays are coupled to microbeamformers 12a and 12b which control transmission and reception of signals by the array elements. Microbeamformers are also capable of at least partial beamforming of the signals received by groups or "patches" of transducer elements as described in U.S. Pat. Nos. 5,997,479 (Savord et al.), 6,013,032 (Savord), and 6,623,432 (Powers et al.) Signals are routed to and from the microbeamformers by a multiplexer 14 by time-interleaving signals. The multiplexer is coupled to a transmit/receive (T/R) switch 16 which switches between transmission and reception and protects the main beamformer 20 from high energy transmit signals. The transmission of ultrasonic beams from the transducer arrays 10a and 10b under control of the microbeamformers 12a and 12b is directed by the transmit controller 18 coupled to the T/R switch, which received input from the user's operation of the user interface or control panel 38.

[0015] The partially beamformed signals produced by the microbeamformers 12a, 12b are coupled to a main beamformer 20 where partially beamformed signals from the individual patches of elements are combined into a fully beamformed signal. For example, the main beamformer 20 may have 128 channels, each of which receives a partially beamformed signal from a patch of 12 transducer elements. In this way the signals received by over 1500 transducer elements of a two dimensional array can contribute efficiently to a single beamformed signal.

[0016] The beamformed signals are coupled to a fundamental/harmonic signal separator **22**. The separator **22** acts to separate linear and nonlinear signals so as to enable the identification of the strongly nonlinear echo signals returned from microbubbles. The separator **22** may operate in a variety of ways such as by bandpass filtering the received signals in fundamental frequency and harmonic frequency bands, or by a process known as pulse inversion harmonic separation. A suitable fundamental/harmonic signal separator is shown and described in international patent publication WO 2005/074805 (Bruce et al.) The separated signals are coupled to a signal processor **24** where they may undergo additional enhancement such as speckle removal, signal compounding, and noise elimination.

[0017] The processed signals are coupled to a B mode processor **26** and a Doppler processor **28**. The B mode processor **26** employs amplitude detection for the imaging of structures in the body such as muscle, tissue, and blood cells. B mode images of structure of the body may be formed in either the harmonic mode or the fundamental mode. Tissues in the body and microbubbles both return both types of signals and the harmonic returns of microbubbles enable microbubbles to be clearly segmented in an image in most applications. The Doppler processor processes temporally distinct signals from tissue and blood flow for the detection of motion of substances in the image field including microbubbles. The structural and motion signals produced by these processors are coupled to a scan converter **32** and a volume renderer **34**, which produce image data of tissue structure, flow, or a combined image of both characteristics. The scan converter will convert echo signals with polar coordinates into image signals of the desired image format such as a sector image in Cartesian coordinates. The volume renderer **34** will convert a 3D data set into a projected 3D image as viewed from a given reference point as described in U.S. Pat. No. 6,530,885 (Entrekin et al.) As described therein, when the reference point of the rendering is changed the 3D image can appear to rotate in what is known as kinetic parallax. This image manipulation is controlled by the user as indicated by the Display Control line between the user interface **38** and the Volume renderer **34**. Also described is the representation of a 3D volume by planar images of different image planes, a technique known as multiplanar reformatting. The volume renderer **34** can operate on image data in either rectilinear or polar coordinates as described in U.S. Pat. No. 6,723,050 (Dow et al.) The 2D or 3D images are coupled from the scan converter and volume renderer to an image processor **30** for further enhancement, buffering and temporary storage for display on an image display **40**.

[0018] A graphics processor **36** is also coupled to the image processor **30** which generates graphic overlays for displaying with the ultrasound images. These graphic overlays can contain standard identifying information such as patient name, date and time of the image, imaging parameters, and the like, and can also produce a graphic overlay of a beam vector steered by the user as described below. For this purpose the graphics processor received input from the user interface **38**. The user interface is also coupled to the transmit controller **18** to control the generation of ultrasound signals from the transducer arrays **10a** and **10b** and hence the images produced by and therapy applied by the transducer arrays. The transmit parameters controlled in response to user adjustment include the MI (Mechanical Index) which controls the peak intensity of the transmitted waves, which is related to cavitation

effects of the ultrasound, steering of the transmitted beams for image positioning and/or positioning (steering) of a therapy beam as discussed below.

[0019] The transducer arrays **10a** and **10b** transmit ultrasonic waves into the cranium of a patient from opposite sides of the head, although other locations may also or alternately be employed such as the front of the head or the sub-occipital acoustic window at the back of the skull. The sides of the head of most patients advantageously provide suitable acoustic windows for transcranial ultrasound at the temporal bones around and above the ears on either side of the head. In order to transmit and receive echoes through these acoustic windows the transducer arrays must be in good acoustic contact at these locations which may be done by holding the transducer arrays against the head with a headset. For instance, FIG. **2a** shows a conventional safety helmet **200** which is adjustably held on the wearer's head by a helmet liner **202** shown in the view of FIG. **2b**. The helmet liner wraps securely about the circumference of the wearer's head. Transducer arrays positioned inside the helmet liner on either side as indicated by the locations of circles **204,206** will be held securely against the skin of the temporal bones of the wearer, enabling the helmet liner **202** to function as a transcranial ultrasound headset. The helmet liner headset is adjustably secured in place by an adjustment knob **208**. An occipital transducer would be positioned at or below the location of adjustment knob **208**. The headset has one or more straps **210** which pass over the top of the head for adjustment of the vertical position of the headset. These straps and other adjustable members of the headset can be elastic or adjustable through other means such as buckles or Velcro®. When properly adjusted the headset will hold the acoustic transducer arrays securely in good acoustic contact on the temples of the patient. Acoustic coupling may be aided by applying an acoustic coupling gel between the transducer and the skin.

[0020] A procedure in accordance with the present invention which uses the ultrasound system and transcranial ultrasound headset just described is illustrated by the flowchart of FIG. **3**. In step **60** the headset is put on the patient with the transducer arrays in acoustic contact with the skin of the patient. The system is activated to image inside the cranium and in step **62** the headset is adjusted until flow inside the cranium can be seen in the ultrasound image of one or (when displayed in duplex) both of the transducer arrays. The colorflow imaging mode of the system is preferably used at this time to produce a two or three dimensional image of the bloodflow inside the cranium. If the cranial flow can be seen in colorflow, the other steps of this procedure can be expected to proceed as desired. When the flow is seen in the ultrasound images the headset is tightened in step **64** to secure the transducer array in their imaging positions. FIG. **4** illustrates the situation at this point for 3D imaging. In this illustration the transducer arrays **10a,10b** are held against the sides of the skull **100** and are imaging 3D image fields **102,104** inside the cranium. The user will see one or both of the 3D image fields **102,104** on the display of the ultrasound system in either a multiplanar or volume rendered 3D projection. The user can manipulate the kinetic parallax control to observe the volume rendered 3D image from different orientations. The user can adjust the relative opacity of the tissue and flow components of the 3D image to better visualize the vascular structure inside the brain tissue as described in U.S. Pat. No. 5,720,291 (Schwartz) or can turn off the B mode (tissue) portion of the

display entirely and just visualize the flow of the vascular structure inside the 3D image field **102,104**.

**[0021]** When the cranium is being imaged successfully a microbubble contrast agent is introduced into the patient's bloodstream at step **66**. In a short time the microbubbles in the bloodstream will be pumped through the carotid arteries and into the cranial vascular system and appear in the image. The clinician user is now able to begin a diagnostic search for blood clots occluding blood vessels in the brain, looking for branches of the vasculature which terminate or are only dimly lighted by echo returns from microbubbles due to a partial occlusion. When a dual display from both transducer arrays is present the clinician is also able to compare the relative symmetry of the two displayed regions, looking for signs of asymmetry. If the clinician finds no signs of occlusion in the vasculature presently being viewed by the image fields **102, 104**, the clinician can steer the image field to other regions of the anatomy as indicated by step **68**. Steering the image field can be done mechanically by physically adjusting the position of a transducer array to aim its image field through different anatomy of the brain. Preferably, the clinician is able to adjust the steering of the beams from the transducer array with a control on the user interface. By adjusting this control (the Beam Steer control line to the transmit controller **18**), the clinician is able to electronically steer the image field around inside the skull without disturbing the acoustic coupling of the array against the head of the patient.

**[0022]** At each position of the image field **102,104** the clinician can look for obstructions of the blood flow in the real time images on the display, or can capture (freeze) an image or map of the cranial vasculature as indicated in step **70**. When the vascular map is acquired and held statically, the image can undergo enhanced processing (e.g., compounding, signal averaging) to improve the resolution or scale of the image and can be manipulated on the screen and examined carefully at different points and from different views in a precise search for blood vessel occlusions. In this way the clinician can diagnose for stenoses as indicated at step **72**. If the clinician examines a vascular map and finds no evidence of obstruction in the blood flow paths, the clinician can steer the image field to another region of the cranium and examine the vascular map of another image field. The clinician can use the Doppler data of the vascular map or the spectral Doppler function of the ultrasound system to take flow velocity measurements at specific points in the cranial vasculature, then use the report generation capabilities of the ultrasound system to record the measurements and prepare a report of his diagnosis.

**[0023]** Examples of vascular maps are shown in FIGS. **6a-6c**. FIG. **6a** illustrates a vascular network **300** of blood vessels. When only flow imaging is performed and the flow image is displayed in the absence of any surrounding B mode tissue structure, as described in U.S. Pat. No. 5,474,073 (Schwartz et al.), only the flow of the vasculature is shown without any obscuring surrounding structure as FIG. **6a** illustrates. The vascular network **300** may be displayed in two dimensions, three dimensions, and by various Doppler techniques such as colorflow (velocity) Doppler or power (intensity) Doppler. In the absence of stenoses the flow network will appear continuous and with velocities and intensities proportionate to vessel size. But if a branch **302** of the vascular network is obstructed, the flow will appear different, e.g., higher velocity and/or intensity, and, if completely obstructed, will disappear entirely in the Doppler flow map as shown in FIG. **6c**. By discerning characteristics such as these,

the clinician can diagnose a stenosis, then direct a therapeutic beam **110** to the suspected location of the obstruction of the vessel as shown in FIG. **6d**.

**[0024]** If the clinician discovers a stenosis, therapy can be applied by agitating or breaking microbubbles at the site of the stenosis in an effort to dissolve the blood clot. The clinician activate the "therapy" mode, and a graphic **110,112** appears in the image field **102,104**, depicting the vector path of a therapeutic ultrasound beam. The therapeutic ultrasound beam is manipulated by a control on the user interface **38** until the vector graphic **110,112** is focused at the site of the blockage, as indicated by step **74**. The therapeutic beam can be a tightly focused, convergent beam or a beam with a relatively long focal length known as a pencil beam. The energy produced for the therapeutic beam can be in excess of the ultrasound levels permitted for diagnostic ultrasound, in which case the microbubbles at the site of the blood clot will be sharply broken. The energy of the resulting microbubble ruptures will strongly agitate the blood clot, tending to break up the clot and dissolve it in the bloodstream. However in some instances insonification of the microbubbles at diagnostic energy levels may be sufficient to dissolve the clot. Rather than breaking in a single event, the microbubbles may be vibrated and oscillated, and the energy from such extended oscillation prior to dissolution of the microbubbles can be sufficient to break up the clot, as indicated at step **76**.

**[0025]** A particularly effective way to insonify the microbubbles is known as "flash" transmission. In flash transmission, insonification is halted to allow the flow of blood to deliver a substantial volume of microbubbles to the site of the blockage. At the end of this pause, a rapid series of high MI pulses are transmitted to rapidly and energetically rupture the microbubbles, which releases energy at the site of the blockage. The gas from the ruptured microbubbles dissolves in the bloodstream. Another pause period commences to allow the buildup of a fresh supply of microbubbles and the process continues. See U.S. Pat. Nos. 5,560,364 (Porter) and 5,685,310 (Porter). The flash technique was improved with the discovery that imaging can be performed at low MI levels as the microbubbles accumulate, enabling the clinician to visually monitor the buildup of microbubbles and determine the optimal time to administer the high MI flash. See U.S. Pat. No. 6,171,246 (Averkiou et al.)

**[0026]** In accordance with a further aspect of the present invention, it has been found that a low duty cycle flash will create rapid microbubble destruction within the energy limits of diagnostic ultrasound. There is thus no need to expose the patient to possibly harmful therapeutic exposure levels. In this technique, the flash pulses are delivered within the MI (instantaneous pressure) limits of diagnostic ultrasound. Another energy limit parameter for ultrasound is the spatial peak temporal average (SPTA), which is a measure of the average energy delivered over time and is related to temperature rise. It has been discovered that a series of high MI pulses (within diagnostic limits) will cause the targeted microbubbles to break up and dissolve in the bloodstream in 100-300 milliseconds. Thus, continued insonification is of no effect, for virtually no microbubbles remain after this period. In the inventive technique, the high MI pulse period has a duty cycle of 50% or less. For instance, the high MI pulses may be delivered for 200 ms, after which high MI pulses are inhibited for the following 800 msec. The duty cycle of the high MI pulse delivery period is thus only 20%. Needless high MI pulses are inhibited and the time averaged energy delivered

over the one second interval is within the temporal average limits of the SPTA parameter. Furthermore, new microbubbles are allowed to reinfuse the blood clot site as soon as the high MI transmission has ceased. Moreover, longer pulse lengths may be employed during the high MI portion of the duty cycle, which have been found to be very effective for microbubble disruption.

[0027] The type of stroke suffered by a patient can be either hemorrhagic stroke or ischemic stroke. Hemorrhagic stroke, which may for instance be caused by a ruptured aneurism, results in blood flow outside of blood vessels and will not be improved by treatment with microbubbles and ultrasound. Furthermore, a hemorrhagic condition is often worsened by the application of tPA. Ischemic stroke caused by a stenosis such as a blood clot is the type of stroke that an embodiment of the present invention is designed to treat. Accordingly it is desirable to initially determine whether the stroke condition is hemorrhagic or ischemic. One way this may be done is by looking for a blood pool outside the vasculature, which is indicative of a hemorrhagic condition. A blood pool will appear black in the standard ultrasound image since blood is not a strong reflector of ultrasonic waves. The blood pool may also exhibit a lower rate of flow (Doppler velocity) than the flow of blood in a containing blood vessel. After the contrast agent is introduced, the perfusion of the contrast agent into the microvasculature of surrounding tissue can create a slight halo effect of brighter contrast about the darkened blood pool in an ultrasound image. It is characteristics such as these which can be used to identify whether the stroke is hemorrhagic or ischemic in origin.

[0028] In the depiction of FIG. 4, each image field 102, 104 is seen to extend almost halfway across the cranium, which is a balance between the size of the image field and the acoustic penetration and attenuation which may be expected through the bone at the acoustic window. For some patients, low attenuation effects may enable an image field to extend fully across the cranium, allowing the clinician to examine the vascular structure near the skull bone on the opposite side of the cranium. By alternately examining image fields of both transducer arrays, the vasculature across the full cranium may be effectively examined. It is possible to acquire extended image fields which cover the same central region of the cranium but image from opposite sides of the head. These images can be correlated and compounded together, forming a fused image that may reveal additional characteristics of the brain. The therapeutic beam can also be transmitted from both sides of the head, enabling breakup of a clot at both sides of the clot. Rather than be limited to reflective ultrasound imaging, through-transmission imaging can be performed by transmitting ultrasound from one transducer array and receiving the remaining unabsorbed ultrasonic energy at the other transducer array, which may reveal yet other characteristics of the brain tissue.

[0029] FIG. 5 illustrates a two dimensional imaging example of the present invention. In this example the transducer array 122 is a one dimensional array which performed 2D imaging. The array is configured as a circular phased array transducer as described in U.S. Pat. No. 5,226,422. This transducer array, like the other arrays described herein, is covered with a lens 124 which electrically insulates the patient from the transducer array and in the case of a one dimensional array may also provide focusing in the elevation (out-of-plane) dimension. The transducer array 122 is backed with acoustic damping material 126 which attenuates acous-

tic waves emanating from the back of the array to prevent their reflection back into the transducer elements. Behind this transducer stack is a device 130 for rotating the image plane 140 of the array. The device 130 may be a simple knob or tab which may be grasped by the clinician to manually rotate the circular array transducer in its rotatable transducer mount (not shown). The device 130 may also be a motor which is energized through a conductor 132 to mechanically rotate the transducer as discussed in U.S. Pat. No. 5,181,514 (Solomon et al.) Rotating the one dimensional array transducer 122 as indicated by arrow 144 will cause its image plane 140 to pivot around its central axis, enabling the repositioning of the image plane for full examination of the vasculature in front of the transducer array. As discussed in the '514 patent, the planes acquired during at least a 180° rotation of the array will occupy a conical volume in front of the transducer array, which may be rendered into a 3D image of that volumetric region. Other planes outside this volumetric region may be imaged by repositioning, rocking or tilting the transducer array in its headset in relation to the skull 100. If a stenosis is found in the image of the plane being imaged, the therapeutic beam vector graphic 142 can be steered by the clinician to aim the beam at the stenosis and therapeutic pulses applied to disrupt the microbubbles at the site of the stenosis.

[0030] It is common in the case of stroke that the affliction will not manifest itself in a single episode, but in repeated episodes as a blood clot or obstruction in the heart, lungs, or blood vessel breaks up gradually, releasing small clots which successively make their way to the vascular system of the brain over time. Thus, a patient who survives an initial stroke event, may be at risk for other events in the near future. Accordingly, it is desirable to monitor these patients for some time after an initial stroke event so that recurrences can be treated immediately. In accordance with a further aspect of the present invention, an embodiment of the invention may be used for the monitoring of stroke victims for recurrent events. The transducer arrays 10a, 10b, microbeamformers 12a, 12b, and multiplexer 14 can be efficiently packaged in a flip-chip configuration as part of the headset. These components can be battery powered and the output of the multiplexer connected to an r.f transmitter. A fixed image field 102, 104 is continually imaged as shown in FIG. 4; it is not necessary to be able to steer or reposition the image field in this embodiment. The image data produced by the microbeamformers 12a, 12b is wirelessly transmitted to a base unit as described in U.S. Pat. No. 6,113,547 (Catallo et al.) At the base station additional beamforming can be performed if necessary as well as the image processing and display functions of the system of FIG. 1. If a patient is not ambulatory a wireless connection may not be necessary and a wired connection to the base station may be employed. The wireless connection is also useful when the headset is being applied by individuals having minimal experience with the device. For example, a first responder may be unsure that the headset is applied properly and is acquiring a satisfactory image data set of the patient's vasculature. In that case the images can be transmitted to a base station, hospital or other location where experienced personnel can view the images in real time and talk the first responder through a successful application of the headset on the patient.

[0031] In the present example, image display is not necessary for the monitoring application. As successive images of the vasculature are formed at the base station they are stored in an image store 52, and temporally different images are compared to detect changes in flow of the vasculature by

operation of flow change detector **50**. The flow change detector operates by comparing the identical nature of the temporally different images, similar to the image data correlation techniques used to identify motion by image processing as described in U.S. Pat. No. 6,442,289 (Olsson et al.) As long as successive images and images separated by greater time intervals appear substantially the same in their flow characteristics, e.g., there is no localized change in the flow characteristics of a particular section of the vasculature and no section of the vasculature has ceased to return a Doppler signal indicating the continuation of flow, the flow change detector **50** will continue its monitoring of the vasculature with no change. For example, the vasculature may appear as the vascular network **300** of FIG. **6a** for an extended period, and suddenly a section of the flow may cease to be detected as illustrated by the absence of vessels **302** in FIG. **6c**. If a flow change such as one of those indicated above is detected by the flow change detector **50**, an alarm is activated such as an audible alarm **42** at a nurse's station. Medical assistance can then be brought immediately to the patient. In addition, the images stored in the image store at the time of the detected flow change can be examined by medical personnel to discern exactly where in the vasculature the detected obstruction occurred. Therapy can then be directed specifically to the site of the obstruction without the need to closely examine a series of vascular maps.

**[0032]** Since this is a monitoring application, image acquisition does not have to be performed at the high rates necessary for real time imaging. A new image could be acquired every second, for example, or at greater intervals between image acquisitions. The lower acquisition rate is helpful for conserving battery power in an ambulatory implementation with an r.f. link. The lower image rate also permits images from multiple patients to be processed in a time-interleaved manner by the same system, which is useful for a nurse's station which needs to monitor multiple patients.

**[0033]** During long term monitoring or monitoring of ambulatory patients it is possible that the headset may move relative to the head of the patient, causing a difference between successive images from a transducer **10a**, **10b** which has moved. Such movement can also cause a specific anatomical region being monitored to move outside of the image field of the transducer array **10a** or **10b**. While the flow change detector **50** can be designed to be immune to such global changes and look only for localized changes in flow, it may be desirable to alert medical personnel to readjust the headset or to reacquire target anatomy in the image field. This is done in the embodiment of FIG. **1** by means of an image field controller **54**, which performs image analysis of temporally different images to detect changes in global alignment of the image data. If the headset has not moved between successive images, for example, the successive images of each transducer array will be the same and the image data of the images will exhibit a high degree of correlation. The image analysis techniques used to measure image alignment in U.S. Pat. Nos. 5,556,674 (Weng), 6,572,549 (Jong et al.) or 6,589,176 (Jago et al.) and others may be used to perform the image comparison, for instance. Movement of the headset will result in a global change in correlation, which can alert medical personnel to adjust the headset. A local change in correlation may be a localized flow change that should be detected by the flow change detector **50** or the local decorrelation can be used to alert medical personnel to check the patient's condition. Another possibility is to use the global correlation vector as

an indication of image-to-image motion. The motional change is then used by the transmit controller **18** to adjust the steering of beams of the image field **102**, **104**, **140** to relocate the anatomy in the same position in the newly acquired image field, as in the manner of image stabilization discussed in the aforementioned U.S. Pat. No. 6,589,176. This will enable the anatomy initially monitored by the system to remain in view and in the image data set despite small changes in the headset positioning. If the target anatomy moves beyond the range of beam steering reacquisition, an alert can be issued for medical personnel to reposition the headset. Such restearing correction in the presence of motion can similarly be used to keep the therapeutic pencil beam **110**, **112** constantly directed at a targeted blood clot being treated.

**[0034]** A typical sequence for a monitoring implementation of the present invention is illustrated by the flowchart of FIG. **7**. The headset with the array transducers is put on the patient at step **60** and images are initially displayed and reviewed until the headset is adjusted so that flow is observed in the images in step **62**. When it is determined that images of cranial flow are being acquired, image display is no longer necessary and the headset is tightened in place on the patient at step **64**. Periodically image data is acquired from the image field of the arrays and transmitted to the monitoring unit at step **80**. At the monitoring unit the image data may be further processed as desired at step **82**, then the new image is compared to one or more previously acquired images at step **84**. If the flow characteristics of the images are unchanged, periodic transmission, reception, and comparison of image data continues. But if the new image is different in a predetermined flow characteristic, the flow change is detected at **86** and an alert issued at **88** for medical attention.

**[0035]** While the monitoring implementation can be performed with 2D (planar) imaging, it is preferred that 3D imaging be used so that a larger volumetric region can be monitored. Monitoring can be performed with only one transducer array, but a greater number of arrays likewise provides monitoring of a larger region of the cranium.

What is claimed is:

1. A stroke therapy system for treating cranial vascular obstructions comprising:
  - a transducer array headset which maintains an ultrasonic transducer array in acoustic contact with the head of a subject;
  - an image processor, coupled to the ultrasonic transducer array, which produces images of blood flow in the cranium of the subject; and
  - an image display, coupled to the image processor, which produces an image of the cranial vasculature.
2. The stroke therapy system of claim **1**, wherein the image processor comprises a Doppler processor,
  - wherein the Doppler processor produces at least one of velocity Doppler images or power Doppler images.
3. The stroke therapy system of claim **1**, wherein the ultrasonic transducer array is further operable in a therapy mode to direct a therapeutic beam at an obstruction site in the cranium of the subject,
  - wherein the therapeutic beam comprises an ultrasonic beam which is capable of disrupting microbubbles at the obstruction site.
4. The stroke therapy system of claim **1**, wherein the transducer array headset maintains a first ultrasonic transducer array in acoustic contact with one side of the head; and

further comprising a second transducer array maintained in acoustic contact with the other side of the head by the headset.

**5.** A stroke therapy system for treating cranial vascular obstructions comprising:

a transducer array headset which maintains an ultrasonic transducer array in acoustic contact with the head of a subject;

an image processor, coupled to the ultrasonic transducer array, which produces images of blood flow in the cranium of the subject;

an image display, coupled to the image processor, which produces an image of the cranial vasculature;

a transmitter, coupled to the transducer array, which acts to cause the ultrasonic transducer array to transmit a therapeutic beam,

wherein imaging and delivery of the therapeutic beam are done by a common ultrasonic transducer array.

**6.** The stroke therapy system of claim **5**, wherein imaging and delivery of the therapeutic beam are both done within the limits for diagnostic ultrasound energy delivery to a subject.

**7.** The stroke therapy system of claim **5**, wherein the transmitter acts to apply at least one of pulse width modulated or duty cycle modulated signals to the transducer array.

**8.** The stroke therapy system of claim **5**, wherein the transmitter further acts to cause the ultrasonic transducer array to transmit beams for at least one of Doppler or B mode imaging.

**9.** The stroke therapy system of claim **8**, wherein the transmitter further acts to transmit beams for imaging over an image field exhibiting a given lateral dimension in the cranium,

wherein the therapeutic beam exhibits a lateral dimension which is less than the given lateral dimension.

**10.** The stroke therapy system of claim **8**, wherein the transmitter further acts to transmit image beams over an image field occupying a given spatial region in the cranium, wherein the therapeutic beam is transmitted over a portion of the given spatial region.

**11.** The stroke therapy system of claim **10**, wherein the ultrasonic transducer array comprises a two dimensional array of transducer elements,

wherein the given spatial region is a volumetric region.

**12.** The stroke therapy system of claim **11**, wherein the two dimensional array is maintained in acoustic contact with one side of the head;

further comprising a second two dimensional array maintained in acoustic contact by the headset with the other side of the head.

**13.** The stroke therapy system of claim **12**, wherein the first two dimensional array scans imaging beams over a majority of the cranial distance between the left side of the head and the center of the cranium; and

wherein the second two dimensional array scans imaging beams over a majority of the cranial distance between the right side of the head and the center of the cranium.

**14.** A method for treating stroke comprising:

applying a headset containing first and second transducer arrays to the head of a subject with the transducer arrays in acoustic contact with opposite sides of the head;

producing an ultrasound image of cranial flow from signals received from at least one of the transducer arrays;

securing the headset to maintain the transducer arrays in acoustic contact with the head;

infusing the blood stream of the subject with microbubbles; and

producing an ultrasound image of cranial flow containing microbubbles.

**15.** The method of claim **14**, further comprising:

detecting a stenosis in the ultrasound image of cranial flow; and

directing a therapeutic ultrasound beam from at least one of the transducer arrays to microbubbles proximal to the stenosis.

**16.** The method of claim **15** wherein directing a therapeutic beam further comprises steering a pencil beam to microbubbles proximal to the stenosis.

**17.** The method of claim **15** wherein directing a therapeutic beam further comprises vibrating microbubbles proximal to the stenosis.

**18.** The method of claim **15** wherein directing a therapeutic beam further comprises breaking microbubbles proximal to the stenosis.

**19.** The method of claim **15**, wherein directing a therapeutic ultrasound beam further comprises transmitting a therapeutic ultrasound beam to microbubbles proximal to the stenosis at an energy level which is within the limits for diagnostic ultrasound.

**20.** the method of claim **14**, wherein applying further comprises applying a headset containing first and second two dimensional transducer arrays,

wherein producing an ultrasound image further comprises producing a three dimensional ultrasound image.

\* \* \* \* \*

专利名称(译)	超声系统用于脑血流成像和微泡增强血凝块溶解		
公开(公告)号	<a href="#">US20100160779A1</a>	公开(公告)日	2010-06-24
申请号	US12/376317	申请日	2007-08-03
[标]申请(专利权)人(译)	皇家飞利浦电子股份有限公司		
申请(专利权)人(译)	皇家飞利浦电子N.V.		
当前申请(专利权)人(译)	皇家飞利浦电子N.V.		
[标]发明人	BROWNING THEODORE J SHI WILLIAM POWERS JEFFRY E AVERKIOU MICHALAKIS GAUTHIER THOMAS		
发明人	BROWNING, THEODORE J. SHI, WILLIAM POWERS, JEFFRY E. AVERKIOU, MICHALAKIS GAUTHIER, THOMAS		
IPC分类号	A61N7/00 A61B8/06		
CPC分类号	A61B5/02007 A61B5/6814 A61B8/06 A61B8/08 A61B8/0808 A61N7/00 A61B8/4281 A61B8/481 A61B8/483 A61B8/488 A61B8/13 A61B8/0816 A61B8/085 A61B8/4227 A61B17/22004 A61B2017/22014 A61B2090/502 A61N2007/0021 A61N2007/0039 A61N2007/0078 A61N2007/0082 A61N2007/0095 G01S7/52041 G01S15/8981		
优先权	60/822106 2006-08-11 US		
其他公开文献	US9630028		
外部链接	<a href="#">Espacenet</a> <a href="#">USPTO</a>		

摘要(译)

描述了一种超声诊断成像系统，其利用固定在患者头部的一个或多个换能器阵列来诊断和治疗中风患者。换能器头戴式耳机产生颅内脉管系统的二维或三维图像，优选地由微泡造影剂辅助。系统产生血管流动图，可以诊断出血栓的迹象。如果检测到血凝块，则在存在造影剂的同时传输治疗束以通过破坏微泡来破坏血凝块。耳机还可以用于监测应用中以检测中风受害者中血凝块的复发。

