



(11) **EP 2 800 400 A1**

(12) **EUROPEAN PATENT APPLICATION**
published in accordance with Art. 153(4) EPC

(43) Date of publication:
05.11.2014 Bulletin 2014/45

(51) Int Cl.:
H04R 17/00 (2006.01) **A61B 8/00** (2006.01)
A61B 18/00 (2006.01) **H01L 41/083** (2006.01)
H01L 41/18 (2006.01) **H04R 17/10** (2006.01)

(21) Application number: **12862613.2**

(22) Date of filing: **22.11.2012**

(86) International application number:
PCT/JP2012/080315

(87) International publication number:
WO 2013/099482 (04.07.2013 Gazette 2013/27)

(84) Designated Contracting States:
AL AT BE BG CH CY CZ DE DK EE ES FI FR GB GR HR HU IE IS IT LI LT LU LV MC MK MT NL NO PL PT RO RS SE SI SK SM TR

(72) Inventor: **ITO, Hiroshi**
Shibuya-ku, Tokyo 151-0072 (JP)

(30) Priority: **26.12.2011 JP 2011283670**

(74) Representative: **Winter, Brandl, Fürniss, Hübner, Röss, Kaiser, Polte - Partnerschaft mbB Patent- und Rechtsanwaltskanzlei Alois-Steinecker-Strasse 22 85354 Freising (DE)**

(71) Applicant: **Olympus Corporation**
Shibuya-ku
Tokyo 151-0072 (JP)

(54) **ULTRASONIC VIBRATION DEVICE, AND ULTRASONIC MEDICAL APPARATUS**

(57) There is provided an ultrasound transducer device 2 including a plurality of piezoelectric single-crystal plates 44a to 44f that are stacked such that polarization components thereof are alternately inverted. The plurality of piezoelectric single-crystal plates 44a to 44f are stacked such that directions thereof in which strain deformation in a direction orthogonal to a direction of voltage application from electrodes 45a, 45b respectively interposed between the plurality of piezoelectric single-crystal plates becomes largest coincide with each other. There is also provided an ultrasound medical apparatus 1 including the ultrasound transducer device 2.

FIG.11

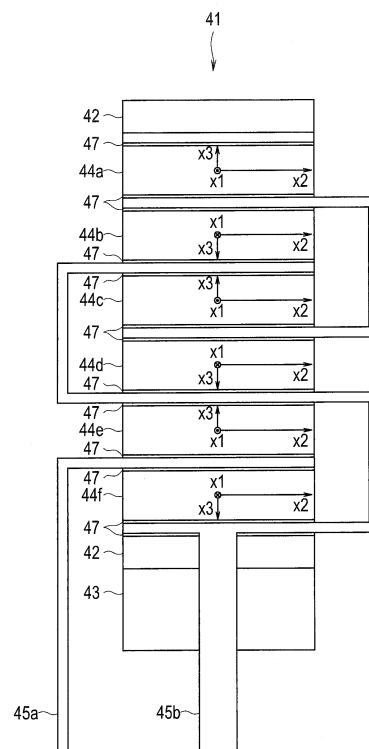

EP 2 800 400 A1

Description

Technical Field

[0001] The present invention relates to an ultrasound transducer device that excites ultrasound vibrations and an ultrasound medical apparatus including the ultrasound transducer device.

Background Art

[0002] In recent years, ultrasound medical apparatuses including ultrasound transducers are known. Examples of the ultrasound medical apparatuses include an ultrasound diagnostic apparatus that images an internal state of a living body and an ultrasound scalpel for coagulation and dissection in a surgery. In these apparatuses, piezoelectric materials are used for the ultrasound transducer that generates ultrasound vibrations from an electric signal, and piezoelectric ceramics typified by PZT (lead zirconate titanate) and piezoelectric single crystals are used therefor. Moreover, the ultrasound transducer may be formed by stacking such piezoelectric materials in a plurality of layers, for the purpose of a reduction in impedance and an increase in output power.

[0003] For example, a technique disclosed in Japanese Patent Application Laid-Open Publication No. 2001-102650 is known as an ultrasound transducer formed by stacking piezoelectric single crystals. The conventional transducer is a stacked piezoelectric single-crystal element formed by: putting two or more single crystals ((1-x)Pb(B1, B2)O₃-xPbTiO₃ (when x = 0-0.55, B1 = Mg, Zn, Ni, Sc, In, Yb, Lu, B2 = Nb, Ta)) having an ABO₃ type perovskite structure on top of each other, using a metal material for bonding; bonding the single crystals to each other by heating; and then polarizing the piezoelectric single-crystal elements.

[0004] The single-crystal material used for the conventional transducer is a uniaxial material, and is polarized in a stacking direction of the piezoelectric elements. Hence, the stacking direction is an axis of rotational symmetry, and deformation in a direction perpendicular to the stacking direction, that is, deformation in a plane of the transducer is the same irrespective of orientation.

[0005] However, for some piezoelectric single-crystal materials, the stacking direction is not an axis of rotational symmetry, a piezoelectric constant is different depending on orientation, and a strain pattern is different. A Langevin type transducer is described as an example. In the Langevin type transducer, at least two or more piezoelectric single-crystal materials whose stacking direction is not an axis of rotational symmetry are stacked on each other, and polarization components in the stacking direction are alternately inverted. In the Langevin type transducer configured as described above, because the piezoelectric single-crystal materials are stacked on each other such that front surfaces and rear surfaces of respective piezoelectric elements are alternately inverted, there is a

problem that deformation in an in-plane direction perpendicular (orthogonal) to the stacking direction, that is, deformation in an in-plane direction of the piezoelectric transducer cannot be made coincident between adjacent piezoelectric transducers in all directions. Further, in the conventional Langevin type transducer, because strain in the in-plane direction is not coincident between adjacent piezoelectric transducers, deformation in the in-plane direction is hindered, and this influences deformation in the stacking direction, so that an excess stress acts on between layers in which deformation due to a same input voltage becomes smaller. Accordingly, the transducer becomes more liable to be broken, and is more likely to be damaged at the time of driving.

[0006] The present invention, which has been made in view of the above-mentioned circumstances, has an object to enable providing an ultrasound transducer device that can minimize a hindrance to deformation in an in-plane direction of a piezoelectric transducer and an excess stress acting on between adjacent transducers, can prevent damage at the time of driving, and can more efficiently obtain deformation in a transducer stacking direction, and an ultrasound medical apparatus using the ultrasound transducer device.

Disclosure of Invention

Means for Solving the Problem

[0007] An ultrasound transducer device according to an aspect of the present invention includes a plurality of piezoelectric single-crystal plates that are stacked such that polarization components thereof are alternately inverted. The plurality of piezoelectric single-crystal plates are stacked such that directions thereof in which strain deformation in a direction orthogonal to a direction of voltage application from electrodes respectively interposed between the plurality of piezoelectric single-crystal plates becomes largest coincide with each other.

[0008] Moreover, an ultrasound medical apparatus according to an aspect of the present invention includes an ultrasound transducer device including a plurality of piezoelectric single-crystal plates that are stacked such that polarization components thereof are alternately inverted. The plurality of piezoelectric single-crystal plates are stacked such that directions thereof in which strain deformation in a direction orthogonal to a direction of voltage application from electrodes respectively interposed between the plurality of piezoelectric single-crystal plates becomes largest coincide with each other.

[0009] According to the present invention described above, it is possible to provide an ultrasound transducer device that can minimize a hindrance to deformation in an in-plane direction of a piezoelectric transducer and an excess stress acting on between adjacent transducers, can prevent damage at the time of driving, and can more efficiently obtain deformation in a piezoelectric single-crystal plates stacking direction, and an ultrasound med-

ical apparatus using the ultrasound transducer device.

Brief Description of the Drawings

[0010]

Fig. 1 is a cross-sectional view illustrating an overall configuration of an ultrasound medical apparatus according to an aspect of the present invention;

Fig. 2 is a view illustrating an overall schematic configuration of a transducer unit according to the aspect of the present invention;

Fig. 3 is a perspective view illustrating a configuration of an ultrasound transducer according to the aspect of the present invention;

Fig. 4 is a partial cross-sectional view illustrating the configuration of the ultrasound transducer according to the aspect of the present invention;

Fig. 5 is a cross-sectional view illustrating a configuration of a stacked transducer according to the aspect of the present invention;

Fig. 6 is a perspective view illustrating a single-crystal wafer according to the aspect of the present invention;

Fig. 7 is a plan view illustrating the single-crystal wafer according to the aspect of the present invention, which is observed from a polished surface side;

Figs. 8 illustrate a strain pattern of each piezoelectric single-crystal plate according to the aspect of the present invention, Fig. 8(a) is a view illustrating a voltage application direction, Fig. 8(b) is a view illustrating perpendicular (orthogonal) strain, and Fig. 8(c) is a view illustrating shear strain;

Fig. 9 is a graph showing substrate in-plane direction dependencies of piezoelectric strain constants according to the aspect of the present invention;

Fig. 10 is a graph showing a substrate in-plane direction dependency of a piezoelectric strain constant obtained by adding the perpendicular strain and the shear strain, according to the aspect of the present invention;

Fig. 11 is a schematic view illustrating a relative relation of a wafer coordinate system of the stacked transducer according to the aspect of the present invention;

Fig. 12 is a plan view illustrating a first example of each piezoelectric single-crystal plate according to the aspect of the present invention and illustrating a direction in which deformation thereof becomes largest;

Fig. 13 is a plan view illustrating a second example of each piezoelectric single-crystal plate according to the aspect of the present invention and illustrating a direction in which deformation thereof becomes largest;

Fig. 14 is a plan view illustrating a third example of each piezoelectric single-crystal plate according to the aspect of the present invention and illustrating a

direction in which deformation thereof becomes largest;

Fig. 15 is a plan view illustrating one surface of each piezoelectric single-crystal plate provided with an electrode on which a first index portion is formed, according to the aspect of the present invention; and Fig. 16 is a plan view illustrating the other surface of each piezoelectric single-crystal plate provided with an electrode on which a second index portion is formed, according to the aspect of the present invention.

Best Mode for Carrying Out the Invention

[0011] Hereinafter, the present invention is described with reference to the drawings. Note that, in the following description, because the drawings based on each embodiment are schematic, a relation in thickness and width among respective portions, a ratio in thickness of each portion, and the like are different from actual values thereof, and a portion in which a relation and a ratio of mutual dimensions are different among the drawings may be included.

(Ultrasound Medical Apparatus)

[0012] Fig. 1 is a cross-sectional view illustrating an overall configuration of an ultrasound medical apparatus according to the present embodiment.

[0013] An ultrasound medical apparatus 1 illustrated in Fig. 1 is mainly provided with: a transducer unit 3 including an ultrasound transducer 2 as an ultrasound device that generates ultrasound vibrations; and a handle unit 4 that treats an affected area using the ultrasound vibrations.

[0014] The handle unit 4 includes an operation portion 5, an insertion sheath portion 8 formed by an elongated cover tube 7, and a distal-end treatment portion 30. A proximal end portion of the insertion sheath portion 8 is attached to the operation portion 5 so as to be rotatable about an axis thereof. The distal-end treatment portion 30 is provided at a distal end of the insertion sheath portion 8. The operation portion 5 of the handle unit 4 includes an operation portion main body 9, a fixed handle 10, a movable handle 11, and a rotating knob 12. The operation portion main body 9 is formed integrally with the fixed handle 10.

[0015] A slit 13 through which the movable handle 11 is inserted is formed on a back side in a coupling part between the operation portion main body 9 and the fixed handle 10. An upper portion of the movable handle 11 is extended inside of the operation portion main body 9 through the slit 13. A handle stopper 14 is fixed to a lower end portion of the slit 13. The movable handle 11 is turnably attached to the operation portion main body 9 by means of a handle support shaft 15. Then, along with a turning motion of the movable handle 11 about the handle support shaft 15, the movable handle 11 is operated to

be opened and closed with respect to the fixed handle 10.

[0016] A substantially U-shaped coupling arm 16 is provided in an upper end portion of the movable handle 11. Moreover, the insertion sheath portion 8 includes the cover tube 7 and an operation pipe 17 that is inserted through an inside of the cover tube 7 so as to be movable in an axis direction. A larger-diameter portion 18 having a diameter larger than that of a distal end portion of the cover tube 7 is formed in a proximal end portion of the cover tube 7. The rotating knob 12 is fitted around the larger-diameter portion 18.

[0017] A ring-shaped slider 20 is provided on an outer circumferential surface of an operation pipe 19 so as to be movable along the axis direction. A fixed ring 22 is arranged behind the slider 20 with the intermediation of a coil spring (elastic member) 21.

[0018] Further, a proximal end portion of a grasping portion 23 is turnably coupled to a distal end portion of the operation pipe 19 by means of an action pin. The grasping portion 23 constitutes a treatment portion of the ultrasound medical apparatus 1 together with a distal end portion 31 of a probe 6. Then, at the time of a moving motion of the operation pipe 19 in the axis direction, the grasping portion 23 is operated to be pushed and pulled in a front-back direction by means of the action pin. At this time, when the operation pipe 19 is operated to move toward an operator's hand side, the grasping portion 23 is turned about a fulcrum pin by means of the action pin. Consequently, the grasping portion 23 is turned in a direction (closing direction) in which the grasping portion 23 approaches the distal end portion 31 of the probe 6. At this time, a living tissue can be grasped between the grasping portion 23 of single swing type and the distal end portion 31 of the probe 6.

[0019] In such a state where the living tissue is grasped, electric power is supplied from an ultrasound power supply to the ultrasound transducer 2, and the ultrasound transducer 2 is vibrated. The resultant ultrasound vibrations are transmitted to the distal end portion 31 of the probe 6. Then, coagulation and dissection of the living tissue grasped between the grasping portion 23 and the distal end portion 31 of the probe 6 is performed using the ultrasound vibrations.

(Transducer Unit)

[0020] Here, the transducer unit 3 is described. Note that Fig. 2 is a view illustrating an overall schematic configuration of the transducer unit 3, and Fig. 3 is a perspective view illustrating an overall schematic configuration of the ultrasound transducer.

[0021] As illustrated in Fig. 2 and Fig. 3, the ultrasound transducer 2 and the probe 6, which is a rod-shaped vibration transmitting member that transmits ultrasound vibrations generated by the ultrasound transducer 2, are integrally incorporated in the transducer unit 3.

[0022] A horn 32 that amplifies an amplitude of the ultrasound vibration is provided continuously with the ul-

trasound transducer 2. The horn 32 is made of duralumin or a titanium alloy such as 64Ti. The horn 32 is formed in a conical shape having an outer diameter that becomes smaller toward a distal end side thereof, and an outward flange 33 is formed in a proximal-end outer circumferential portion of the horn 32.

[0023] The probe 6 includes a probe main body 34 made of a titanium alloy such as 64Ti. The ultrasound transducer 2 provided continuously with the horn 32 is arranged on a proximal end portion side of the probe main body 34. In this way, the transducer unit 3 in which the probe 6 and the ultrasound transducer 2 are integrated with each other is formed.

[0024] Then, the ultrasound vibrations generated by the ultrasound transducer 2 are amplified by the horn 32, and are then transmitted to the distal end portion 31 side of the probe 6. The treatment portion (to be described later) that treats a living tissue is formed in the distal end portion 31 of the probe 6.

[0025] Moreover, on an outer circumferential surface of the probe main body 34, two rubber linings 35 that are each formed into a ring shape using an elastic member are attached with a space therebetween at several vibration node positions in the middle of the axis direction. Then, the rubber linings 35 prevent the outer circumferential surface of the probe main body 34 and the operation pipe 19 to be described later from coming into contact with each other. That is, at the time of assembling of the insertion sheath portion 8, the probe 6 as a transducer-integrated probe is inserted into the operation pipe 19. At this time, the rubber linings 35 prevent the outer circumferential surface of the probe main body 34 and the operation pipe 19 from coming into contact with each other.

[0026] Note that the ultrasound transducer 2 is electrically connected to a power supply apparatus main body (not illustrated) that supplies current for generating ultrasound vibrations, via an electric cable 36. Electric power is supplied from the power supply apparatus main body to the ultrasound transducer 2 through wires in the electric cable 36, whereby the ultrasound transducer 2 is driven.

(Ultrasound Transducer)

[0027] Here, the ultrasound transducer 2 of the transducer unit 3 is described below. Note that Fig. 4 is a partial cross-sectional view illustrating the configuration of the ultrasound transducer, and Fig. 5 is a cross-sectional view illustrating a configuration of a stacked transducer.

[0028] As illustrated in Fig. 3 and Fig. 4, the ultrasound transducer 2 as the ultrasound device of the transducer unit 3 includes: a cylindrical case body 37 joined to the horn 32; and a bend preventer 38 behind which the electric cable 36 extends, the bend preventer 38 being provided continuously with a proximal end of the case body 37, in order from the distal end.

[0029] A stacked transducer 41 is arranged in the case body 37. Insulating plates 42 are respectively provided on a distal end side and a proximal end side of the stacked transducer 41. A plurality of (here, six) piezoelectric single-crystal plates 44a to 44f are stacked between the insulating plate 42 on the distal end side that is fixed to a proximal end surface of the horn 32 and the insulating plate 42 on the proximal end side that is joined to and provided continuously with a front side of a back mass 43. The piezoelectric single-crystal plates 44a to 44f are stacked such that polarization components in a stacking direction are alternately inverted between adjacent plates.

[0030] Moreover, in order to enable voltage application to the respective piezoelectric single-crystal plates 44a to 44f, a bendable positive electrode plate 45a and a bendable negative electrode plate 45b made of copper foil are alternately sandwiched between the respective piezoelectric single-crystal plates 44a to 44f, and are extended behind the stacked transducer 41. Note that each of the electrode plates 45a, 45b is connected to a same polarization surface of each of the piezoelectric single-crystal plates 44a to 44f.

[0031] The electrode plates 45a, 45b are respectively connected to wires 46a, 46b arranged in the electric cable 36. Then, the respective electrode plates 45a, 45b apply voltage to the piezoelectric single-crystal plates 44a to 44f, and ultrasonically vibrate the stacked transducer 41 in the stacking direction of the piezoelectric single-crystal plates 44a to 44f, due to a piezoelectric effect.

[0032] Moreover, as illustrated in Fig. 5, the insulating plates 42, the back mass 43, the piezoelectric single-crystal plates 44a to 44f, and the respective electrode plates 45a, 45b are bonded to and integrated with one another using a joining material 47. Examples of the joining material 47 include organic materials such as conductive adhesives and metal materials such as solders. Moreover, the stacked transducer 41 is configured as a bolt-clamped Langevin transducer, and the horn 32 and the back mass 43 are fastened to each other using bolts, whereby the horn 32, the insulating plates 42, the back mass 43, the piezoelectric single-crystal plates 44a to 44f, and the respective electrode plates 45a, 45b may be integrated with one another.

(Piezoelectric Single-Crystal Plate)

[0033] Hereinafter, the piezoelectric single-crystal plates 44a to 44f used in the present embodiment are described below. Note that description is given of a case where the piezoelectric single-crystal plates 44a to 44f here are made of LiNbO₃ (lithium niobate) that is a lead-free single-crystal material not containing lead (Pb) and where a 36° Y-cut substrate suitable to obtain vibrations in a wafer thickness direction is used for each of the piezoelectric single-crystal plates 44a to 44f.

[0034] Note that Fig. 6 is a perspective view illustrating a single-crystal wafer, and Fig. 7 is a plan view illustrating

the single-crystal wafer, which is observed from a polished surface side.

[0035] A LiNbO₃ single-crystal wafer 50 illustrated in Fig. 6 and Fig. 7 is processed into such a wafer shape that has a particular orientation with respect to crystal axes (X, Y, Z), in order to obtain desired characteristics depending on an intended use. For example, although a wafer called 128° Y-cut is used for a SAW (surface acoustic wave) device, in the piezoelectric single-crystal plates 44a to 44f of the present embodiment, vibrations in the stacking direction are obtained by stacking LiNbO₃ piezoelectric single crystals, and hence the 36° Y-cut substrate that makes a piezoelectric constant in the stacking direction larger is suitable.

[0036] A direction of the LiNbO₃ single-crystal wafer 50 to each crystal axis is defined by an Euler angle. In a coordinate system (x1, x2, x3) on the wafer 50, a direction perpendicular (orthogonal) to a polished surface 51 of the wafer 50 is defined as an x3 axis, an OF (orientation flat) direction from a center of the wafer 50 is defined as an x1 axis, and an x2 direction is selected such that the x1 axis, an x2 axis, and the x3 axis form a right-handed orthogonal coordinate system.

[0037] The crystal axes (X, Y, Z) of the LiNbO₃ single crystal used for each of the piezoelectric single-crystal plates 44a to 44f and the coordinate system (x1, x2, x3) on the wafer 50 are associated with each other by Euler angles (ϕ , ψ , θ). The polished surface 51 plane of the wafer 50 is determined by the Euler angles ϕ , ψ , and the OF (orientation flat) direction, that is, a direction of the x3 axis is determined by the Euler angle θ . Each of the piezoelectric single-crystal plates 44a to 44f here is processed into a rectangular or discoid chip through dicing or machining of a LiNbO₃ 36° Y-cut substrate having such a particular orientation that the Euler angles with respect to the crystal axes (X, Y, Z) are (180°, 54°, 180°).

[0038] Figs. 8 illustrate deformation in a direction perpendicular (orthogonal) to a voltage application direction in a case where voltage is applied in a thickness direction of each of the piezoelectric single-crystal plates 44a to 44f. Note that Figs. 8 illustrate a strain pattern of each piezoelectric single-crystal plate, Fig. 8(a) is a view illustrating the voltage application direction, Fig. 8(b) is a view illustrating perpendicular (orthogonal) strain, and Fig. 8(c) is a view illustrating shear strain. As illustrated in Figs. 8, the strain pattern of each of the piezoelectric single-crystal plates 44a to 44f includes two types of strain, that is, the perpendicular (orthogonal) strain illustrated in Fig. 8(b) and the shear strain illustrated in Fig. 8(c), with respect to the voltage application direction illustrated in Fig. 8(a).

[0039] For the perpendicular strain in the piezoelectric single-crystal plates 44a to 44f, the piezoelectric single-crystal plates 44a to 44f wholly expand and contract in the direction orthogonal to the voltage application direction. In contrast, for the shear strain in the piezoelectric single-crystal plates 44a to 44f, a voltage application surface is displaced in the direction orthogonal to the voltage

application direction, and a cross-section of each of the piezoelectric single-crystal plates 44a to 44f obliquely strains.

[0040] A magnitude of strain when voltage is applied to the piezoelectric single-crystal plates 44a to 44f is expressed by a piezoelectric strain constant d . Assuming that the voltage application direction is the three axis directions of the coordinate system, the perpendicular strain is expressed by d_{31} , d_{32} , and the shear strain is expressed by d_{35} , d_{34} . In a case of a piezoelectric single crystal as in the present embodiment, the piezoelectric constant is different in a transducer plane depending on a direction, due to crystal anisotropy.

[0041] Here, 36° Y-cut substrate in-plane direction dependencies of the piezoelectric strain constants d_{31} , d_{35} are described. Note that Fig. 9 is a graph showing substrate in-plane direction dependencies of piezoelectric strain constants, and Fig. 10 is a graph showing a substrate in-plane direction dependency of a piezoelectric strain constant obtained by adding the perpendicular strain and the shear strain.

[0042] An x axis of the graph shown in Fig. 9 is the Euler angle θ , and represents a direction in the wafer 50 plane. Moreover, Fig. 10 shows a piezoelectric strain constant $d_{31} + d_{35}$. Note that an absolute value of each value represents a magnitude of strain. As is apparent from these graphs, both the piezoelectric strain constants d_{31} , d_{35} become largest, and the shear strain becomes largest, in a direction of the Euler angle $\theta = 270$ degrees, that is, in the direction of the x_2 axis in the wafer coordinate system of Fig. 6 and Fig. 7.

[0043] Accordingly, as illustrated in Fig. 11, the stacked transducer 41 of the ultrasound transducer 2 of the present embodiment is configured as the Langevin transducer in the following manner. That is, front sides and rear sides of the respective piezoelectric single-crystal plates 44a to 44f are alternately stacked such that the x_2 axes thereof in the coordinate system on the wafer 50 coincide with each other, in terms of a relative relation of the wafer coordinate system. Note that Fig. 11 is a schematic view illustrating the relative relation of the wafer coordinate system of the stacked transducer.

[0044] As a result, in the ultrasound transducer 2, a difference in in-plane deformation becomes smallest between adjacent ones of the piezoelectric single-crystal plates 44a to 44f of the stacked transducer 41. Accordingly, a hindrance to deformation in the in-plane direction can be reduced, damage at the time of driving can be prevented, and vibrations in the stacking direction can be efficiently obtained.

[0045] Further, because the ultrasound transducer 2 is formed using the piezoelectric single-crystal plates 44a to 44f based on the LiNbO₃ 36° Y-cut substrates each made of a lead-free single-crystal material, the ultrasound transducer 2 can have a configuration suitable for non-lead environmental protection that has been desired in recent years. Moreover, the piezoelectric single-crystal plates 44a to 44f are not limited to the lithium niobate

single-crystal material, and, for example, a lithium tantalate piezoelectric single crystal can also be used therefor as long as front sides and rear sides of the piezoelectric single-crystal plates 44a to 44f are alternately stacked such that the axes thereof in the wafer coordinate system along which the shear strain becomes largest coincide with each other.

[0046] Note that, as illustrated in Fig. 12 to Fig. 14, an outer shape of each of the piezoelectric single-crystal plates 44a to 44f is processed into a circular or rectangular shape such that a direction (in the drawings, an x' direction) in which deformation in a direction orthogonal to the stacking direction (in-plane deformation of a transducer single plate) becomes largest is an axis of line symmetry. If the outer shape is processed into such a shape, excited ultrasound vibrations are made stable, and an outer circumferential shape of the stacked transducer 41 is made even because the piezoelectric single-crystal plates 44a to 44f are stacked such that the x' axis directions thereof coincide with each other. In particular, in a case where the outer shape of the transducer is processed into the rectangular shape, when the piezoelectric single-crystal plates 44a to 44f are stacked such that the x' axis directions thereof coincide with each other and that polarization components thereof in the stacking direction are alternately inverted, the outer shape of the stacked body becomes a continuous plane, and hence the stacked transducer 41 is more easily manufactured. Note that Fig. 11 to Fig. 14 are plan views each illustrating a direction in which deformation in each piezoelectric single-crystal plate becomes largest.

[0047] Here, if the wafer 50 is processed into chips, that is, the piezoelectric single-crystal plates 44a to 44f, the following problem arises: a relation between the coordinate system on the wafer 50 and orientations of the chips cannot be recognized by appearance. In view of this, a step of forming electrodes in a wafer shape is provided, the electrodes are patterned, and marks that enable identification of an axis of symmetry and front and rear surfaces are formed on the axis of symmetry on the front and rear surfaces, respectively, whereby recognition of an orientation of a transducer can be facilitated. Normally, in a case where a plurality of transducers are integrated with each other by solders or the like, an electrode forming step is necessary. Hence, in such a case, desired marks can be created without the need to add an extra process.

[0048] For example, as illustrated in Fig. 15 and Fig. 16, each of the piezoelectric single-crystal plates 44a to 44f has one surface provided with an electrode 52 on which a first index portion 53 is formed and the other surface provided with an electrode 52 on which a second index portion 54 is formed. Note that Fig. 15 is a plan view illustrating the one surface of each piezoelectric single-crystal plate provided with the electrode on which the first index portion is formed, and Fig. 16 is a plan view illustrating the other surface of each piezoelectric single-crystal plate provided with the electrode on which the

second index portion is formed.

[0049] The electrodes 52 are respectively formed on both the surfaces of each of the piezoelectric single-crystal plates 44a to 44f through metal film formation and patterning. The metal film formation is performed using vapor deposition, sputtering, plating, and the like that are generally adopted, and the patterning is performed using photolithography, etching, and the like.

[0050] As the indexes, the first index portion 53 of one notch is formed as an electrode pattern on one main surface on the axis of symmetry, and the second index portion 54 of two notches having a shape different from that of the first index portion 53 is formed as an electrode pattern on the opposite surface.

[0051] Then, the piezoelectric single-crystal plates 44a to 44f are stacked by bringing the electrodes 52 into surface contact with each other such that the first index portions 53 match to each other and the second index portions 54 match to each other, whereby the stacked transducer 41 of the ultrasound transducer 2, which is stacked such that the polarization components in the stacking direction are alternately inverted and that the directions (x' directions) in which deformation in the direction orthogonal to the stacking direction (in-plane deformation of the transducer single plate) becomes largest coincide with each other, can be easily created. Note that shapes of the index portions 53, 54 may be any shapes as long as the front and rear surfaces of the piezoelectric single-crystal plates 44a to 44f and a position of the axis of symmetry can be identified.

[0052] The invention described in the above-mentioned embodiment is not limited to the embodiment and modifications thereof, and can be variously modified in a practical phase thereof within a range not departing from the gist thereof. Further, the above-mentioned embodiment includes inventions in various phases, and various inventions can be extracted from appropriate combinations of a plurality of disclosed constituent features.

[0053] For example, even if some of all the constituent features disclosed in the embodiment are deleted, in a case where the described problems can be solved and where the described effects can be obtained, the configuration in which some of all the constituent features are deleted can be extracted as an invention.

[0054] The present application claims priority to Japanese Patent Application No. 2011-283670 filed on December 26, 2011 in Japan, the contents of which are incorporated by reference in the description, the claims, and the drawings of the present application.

Claims

1. An ultrasound transducer device comprising a plurality of piezoelectric single-crystal plates that are stacked such that polarization components thereof are alternately inverted, wherein the plurality of piezoelectric single-crystal plates are

stacked such that directions thereof in which strain deformation in a direction orthogonal to a direction of voltage application from electrodes respectively interposed between the plurality of piezoelectric single-crystal plates becomes largest coincide with each other.

2. The ultrasound transducer device according to claim 1, wherein the plurality of piezoelectric single-crystal plates are each made of a lead-free material.

3. The ultrasound transducer device according to claim 2, wherein the plurality of piezoelectric single-crystal plates are each made of a lithium niobate or lithium tantalate piezoelectric single crystal.

4. The ultrasound transducer device according to any one of claim 1 to claim 3, wherein the plurality of piezoelectric single-crystal plates are each bilaterally symmetric with respect to a direction in which strain deformation in a direction orthogonal to a stacking direction becomes largest, as an axis of symmetry.

5. The ultrasound transducer device according to claim 4, wherein the plurality of piezoelectric single-crystal plates each include index portions on the axis of symmetry on front and rear surfaces thereof, respectively, the index portions enabling identification of the direction in which the strain deformation becomes largest and the front and rear surfaces.

6. The ultrasound transducer device according to claim 5, wherein the electrodes are respectively pattern-formed on the front and rear surfaces of the plurality of piezoelectric single-crystal plates, and parts of the electrodes are respectively formed as the index portions into such different shapes that enable identification of the direction in which the strain deformation becomes largest and the front and rear surfaces.

7. An ultrasound medical apparatus comprising the ultrasound device according to any one of claim 1 to claim 6.

50

55

FIG.2

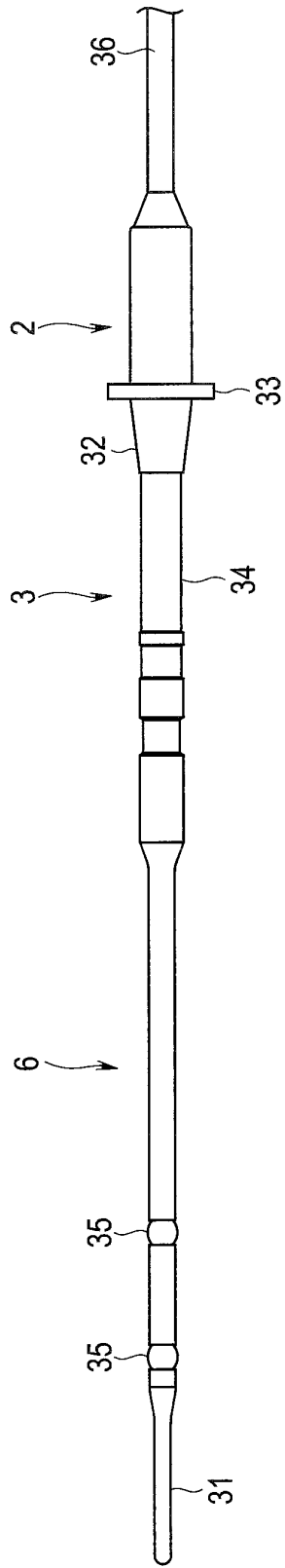

FIG.3

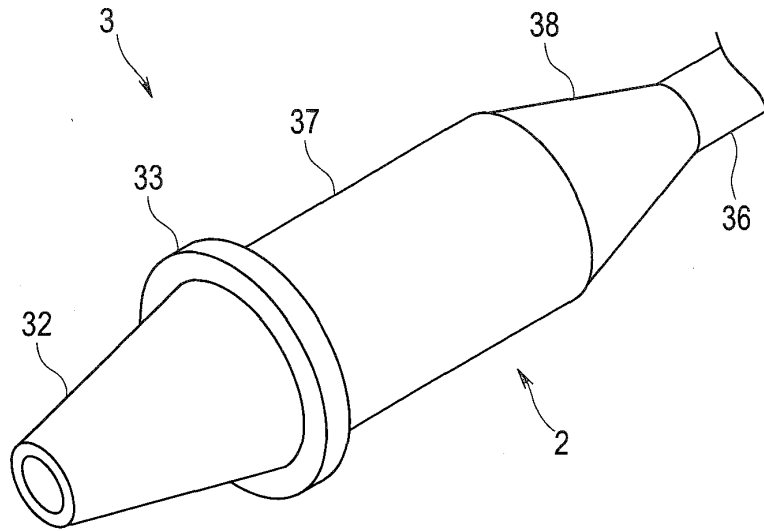

FIG.4

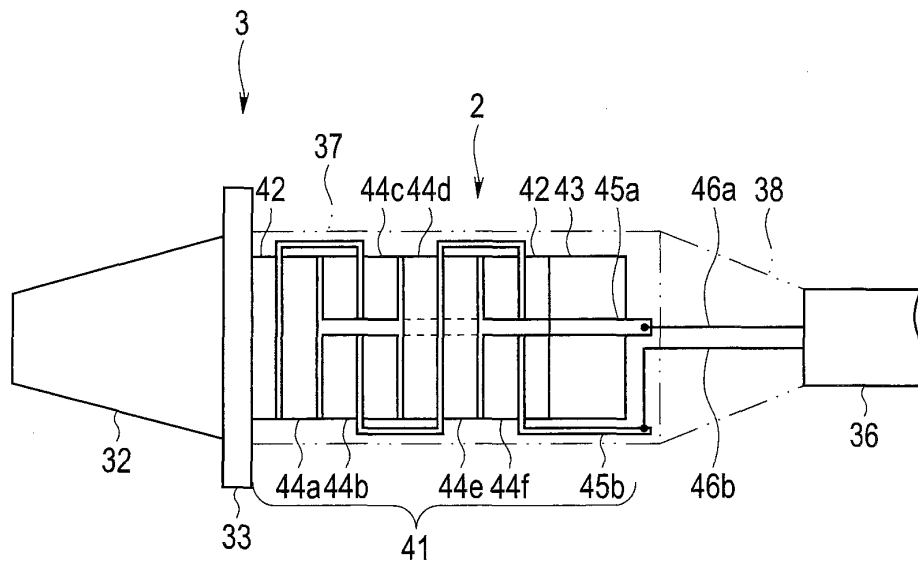

FIG.6

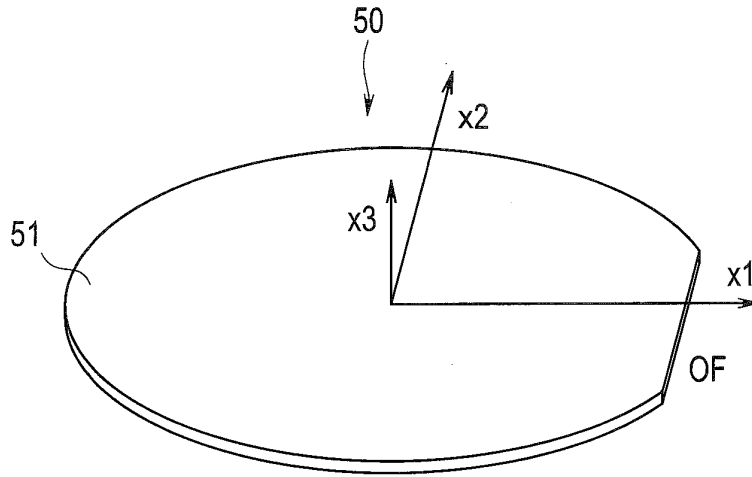

FIG.7

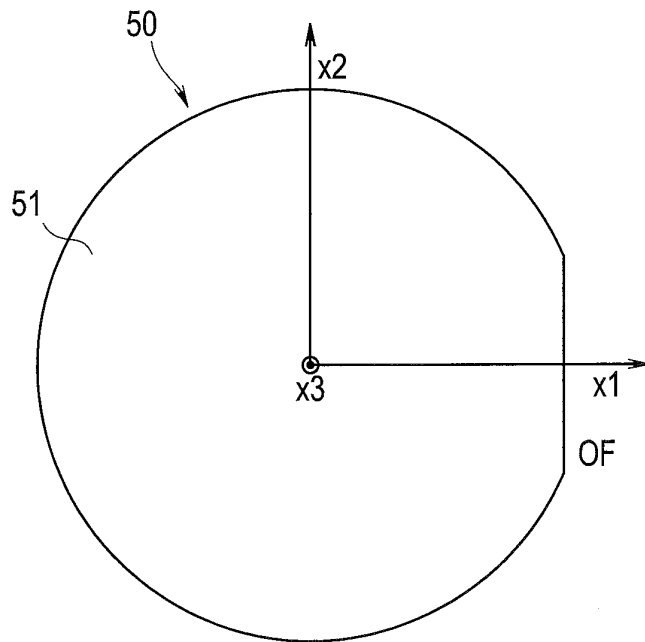

FIG.8

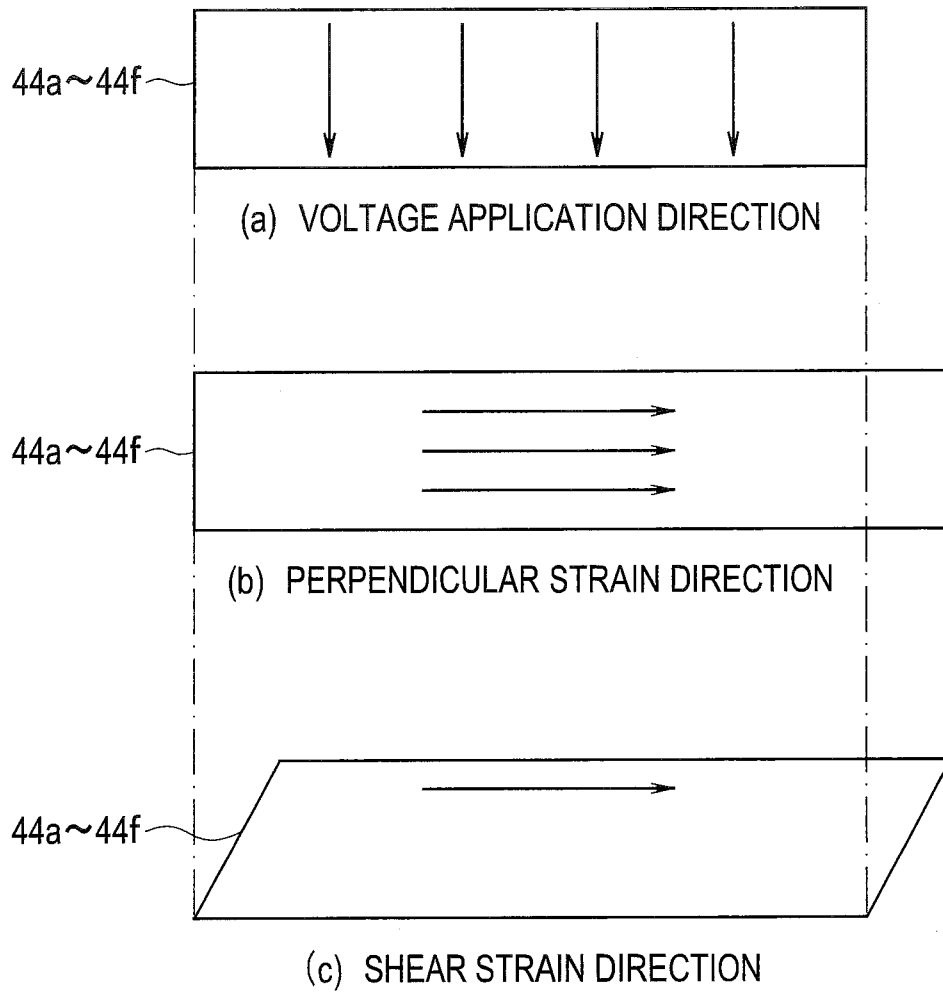

FIG.9

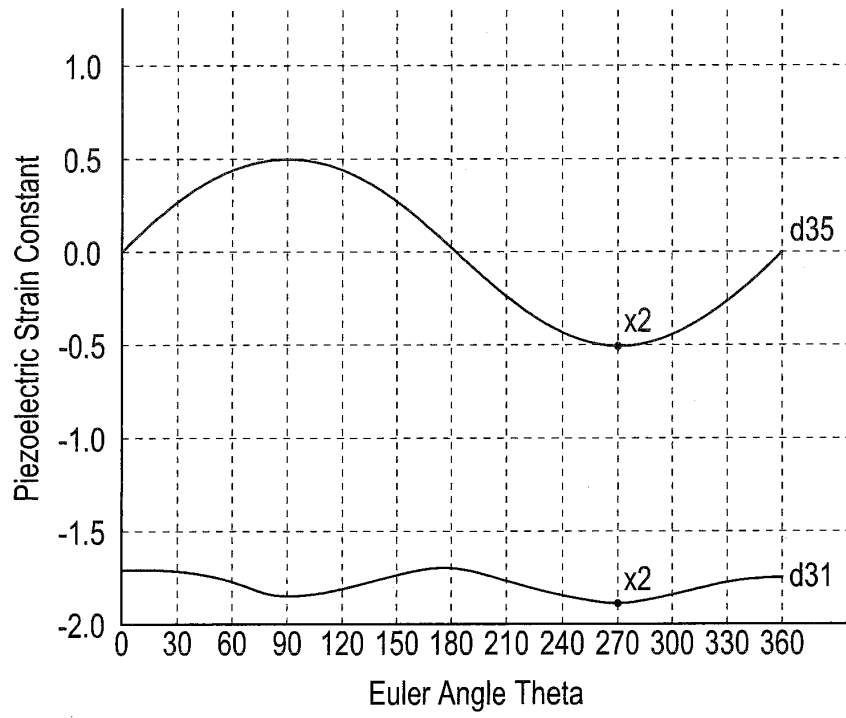

FIG.10

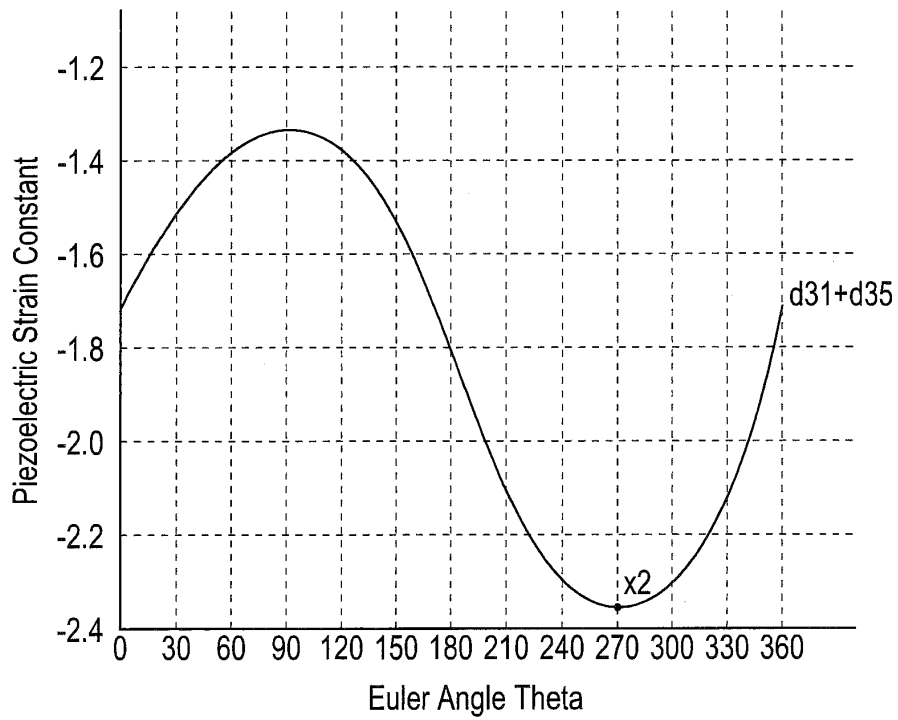

FIG.11

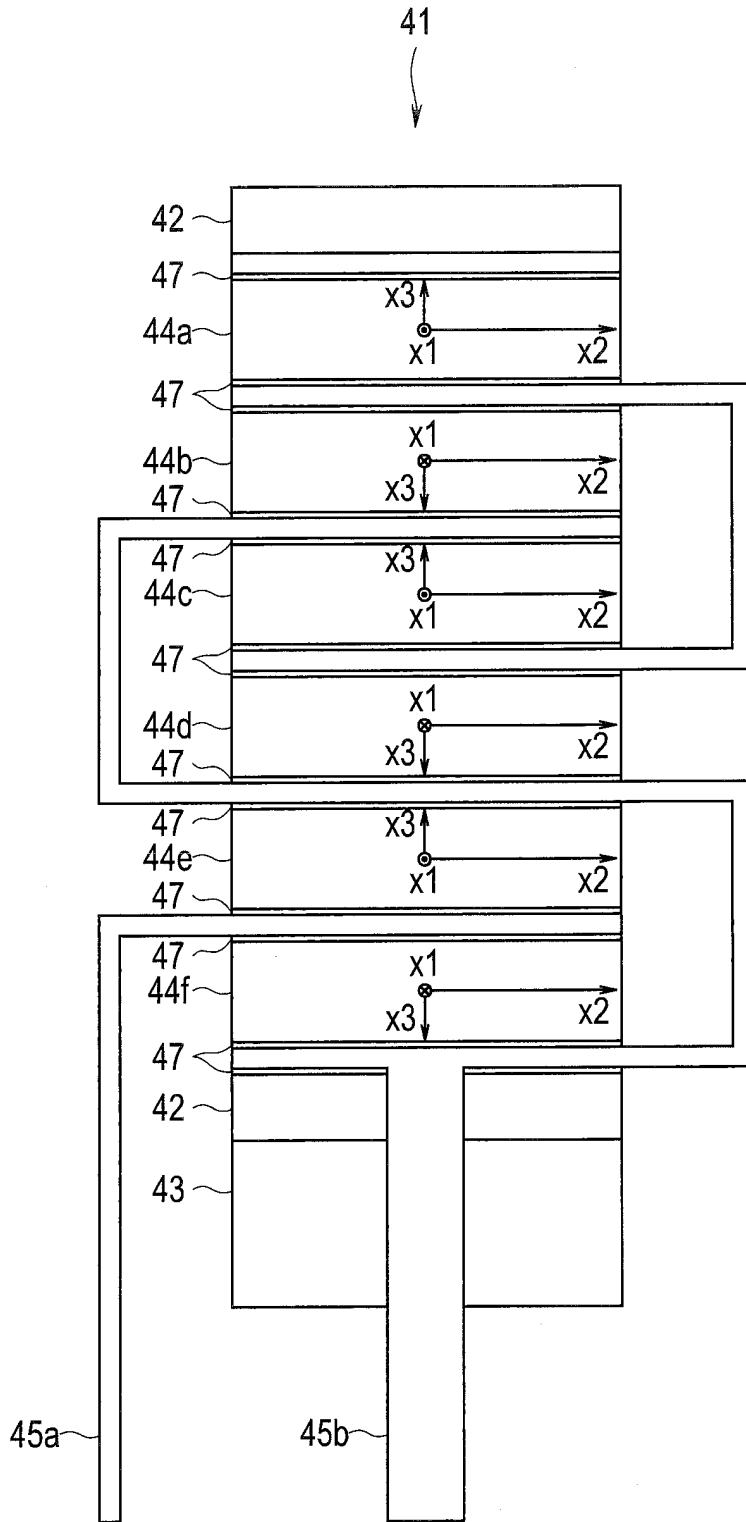

FIG.12

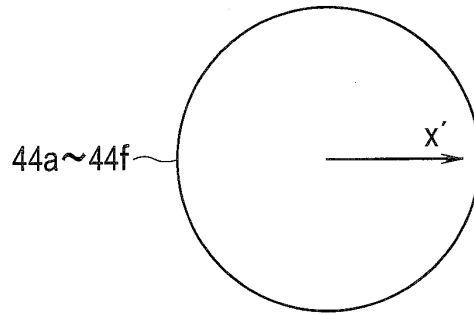

FIG.13

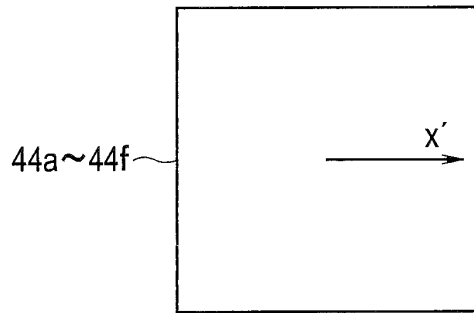

FIG.14

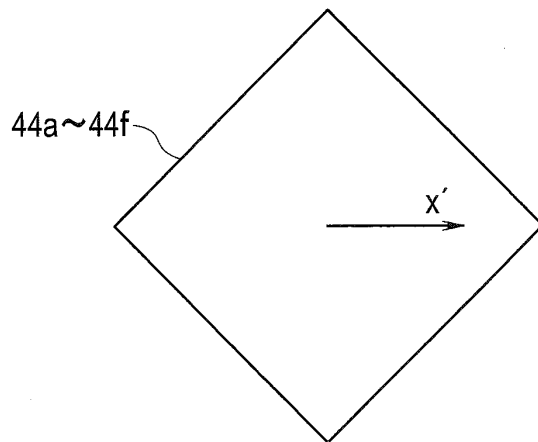

FIG.15

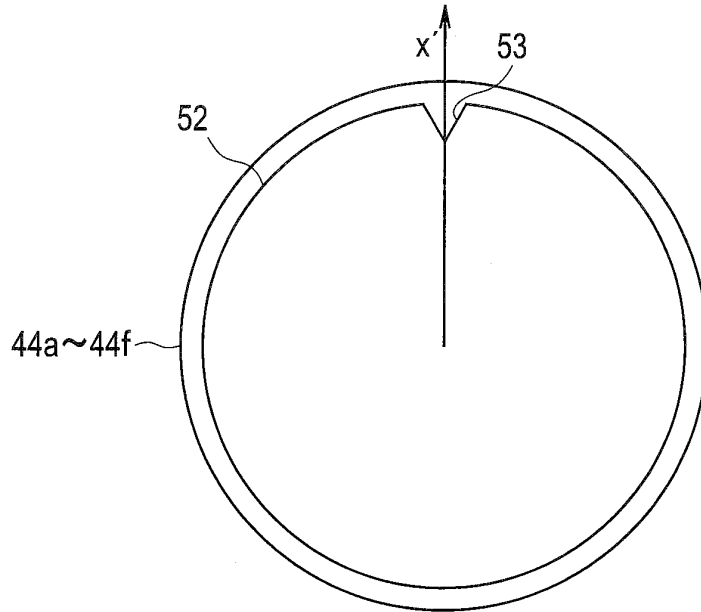
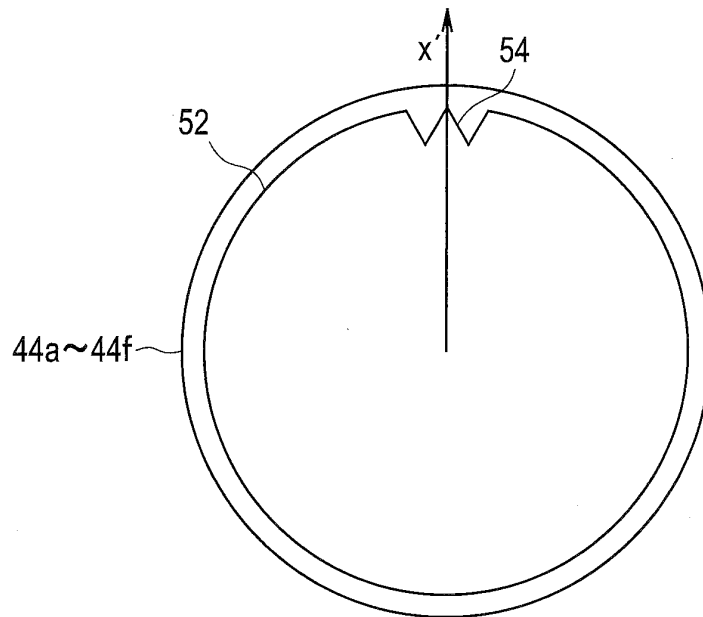

FIG.16



INTERNATIONAL SEARCH REPORT

International application No.

PCT/JP2012/080315

A. CLASSIFICATION OF SUBJECT MATTER

H04R17/00(2006.01)i, A61B8/00(2006.01)i, A61B18/00(2006.01)i, H01L41/083
(2006.01)i, H01L41/18(2006.01)i, H04R17/10(2006.01)i

According to International Patent Classification (IPC) or to both national classification and IPC

B. FIELDS SEARCHED

Minimum documentation searched (classification system followed by classification symbols)

H04R17/00, A61B8/00, A61B18/00, H01L41/083, H01L41/18, H04R17/10

Documentation searched other than minimum documentation to the extent that such documents are included in the fields searched

Jitsuyo Shinan Koho 1922-1996 Jitsuyo Shinan Toroku Koho 1996-2013
Kokai Jitsuyo Shinan Koho 1971-2013 Toroku Jitsuyo Shinan Koho 1994-2013

Electronic data base consulted during the international search (name of data base and, where practicable, search terms used)

C. DOCUMENTS CONSIDERED TO BE RELEVANT

Category*	Citation of document, with indication, where appropriate, of the relevant passages	Relevant to claim No.
X	JP 2004-080193 A (Toshiba Corp.), 11 March 2004 (11.03.2004), paragraphs [0003], [0009]; fig. 1 (Family: none)	1-7
A	JP 2011-139295 A (NGK Insulators, Ltd.), 14 July 2011 (14.07.2011), entire text; all drawings (Family: none)	1-7

Further documents are listed in the continuation of Box C. See patent family annex.

* Special categories of cited documents:

"A" document defining the general state of the art which is not considered to be of particular relevance

"E" earlier application or patent but published on or after the international filing date

"L" document which may throw doubts on priority claim(s) or which is cited to establish the publication date of another citation or other special reason (as specified)

"O" document referring to an oral disclosure, use, exhibition or other means

"P" document published prior to the international filing date but later than the priority date claimed

"T" later document published after the international filing date or priority date and not in conflict with the application but cited to understand the principle or theory underlying the invention

"X" document of particular relevance; the claimed invention cannot be considered novel or cannot be considered to involve an inventive step when the document is taken alone

"Y" document of particular relevance; the claimed invention cannot be considered to involve an inventive step when the document is combined with one or more other such documents, such combination being obvious to a person skilled in the art

"&" document member of the same patent family

Date of the actual completion of the international search
09 January, 2013 (09.01.13)

Date of mailing of the international search report
22 January, 2013 (22.01.13)

Name and mailing address of the ISA/
Japanese Patent Office

Authorized officer

Facsimile No.

Telephone No.

Form PCT/ISA/210 (second sheet) (July 2009)

REFERENCES CITED IN THE DESCRIPTION

This list of references cited by the applicant is for the reader's convenience only. It does not form part of the European patent document. Even though great care has been taken in compiling the references, errors or omissions cannot be excluded and the EPO disclaims all liability in this regard.

Patent documents cited in the description

- JP 2001102650 A [0003]
- JP 2011283670 A [0054]

专利名称(译)	超声波振动装置和超声波医疗器械		
公开(公告)号	EP2800400A1	公开(公告)日	2014-11-05
申请号	EP2012862613	申请日	2012-11-22
[标]申请(专利权)人(译)	奥林巴斯株式会社		
申请(专利权)人(译)	OLYMPUS CORPORATION		
当前申请(专利权)人(译)	OLYMPUS CORPORATION		
[标]发明人	ITO HIROSCHI		
发明人	ITO, HIROSCHI		
IPC分类号	H04R17/00 A61B8/00 A61B18/00 H01L41/083 H01L41/18 H04R17/10 A61B17/32 B06B1/06		
CPC分类号	H01L41/083 A61B8/4483 A61B2017/320093 A61B2017/320095 B06B1/0611 H01L41/0833 H01L41/18 H01L41/277		
优先权	2011283670 2011-12-26 JP		
其他公开文献	EP2800400A8 EP2800400A4 EP2800400B1		
外部链接	Espacenet		

摘要(译)

提供了一种超声换能器装置2，其包括多个压电单晶板44a至44f，所述多个压电单晶板44a至44f堆叠成使得其偏振分量交替反转。多个压电单晶板44a至44f堆叠成使得其中在分别插入多个压电单晶板之间的电极45a，45b的与施加电压的方向垂直的方向上的应变变形变得最大的方向一致彼此。还提供了一种包括超声换能器设备2的超声医疗设备1。

