



(11) **EP 1 901 280 A3**

(12) **EUROPEAN PATENT APPLICATION**

(88) Date of publication A3:  
**29.12.2010 Bulletin 2010/52**

(51) Int Cl.:  
**G10K 11/02 (2006.01)**

(43) Date of publication A2:  
**19.03.2008 Bulletin 2008/12**

(21) Application number: **07024017.1**

(22) Date of filing: **19.03.2002**

(84) Designated Contracting States:  
**DE FR GB IT**

(72) Inventor: **Sato, Shohei**  
**Mitaka-shi**  
**Tokyo 181-8622 (JP)**

(30) Priority: **27.09.2001 JP 2001298372**

(74) Representative: **Heim, Hans-Karl et al**  
**Weber & Heim**  
**Patentanwälte**  
**Irmgardstrasse 3**  
**81479 München (DE)**

(62) Document number(s) of the earlier application(s) in accordance with Art. 76 EPC:  
**02006207.1 / 1 298 642**

(71) Applicant: **Aloka Co., Ltd.**  
**Mitaka-shi**  
**Tokyo 181-8622 (JP)**

(54) **Ultrasonic probe**

(57) An ultrasonic probe which is used for ultrasonic diagnosis comprises a transducer element (10), a sonic speed control element (50), and an acoustic matching layer (52). The sonic speed control element has a function to control the sonic speed of the ultrasonic waves traveling therethrough, and has an inclined characteristic in the sonic speed control effect in which the sonic speed control effect changes continuously along the direction of travel of the ultrasonic waves (thickness direction). The specific acoustic impedance of the sonic speed control element at the end near the living body (26) corresponds to the specific acoustic impedance of the acoustic matching layer at the end away from the living body. The acoustic matching layer is preferably formed by layering 2 or 3 or more overlapped members. The boundary between two adjacent members has a shape with a plurality of hills and valleys. The crossing angle between the direction of travel of the ultrasonic waves and the boundary is set so that a predetermined condition is satisfied.

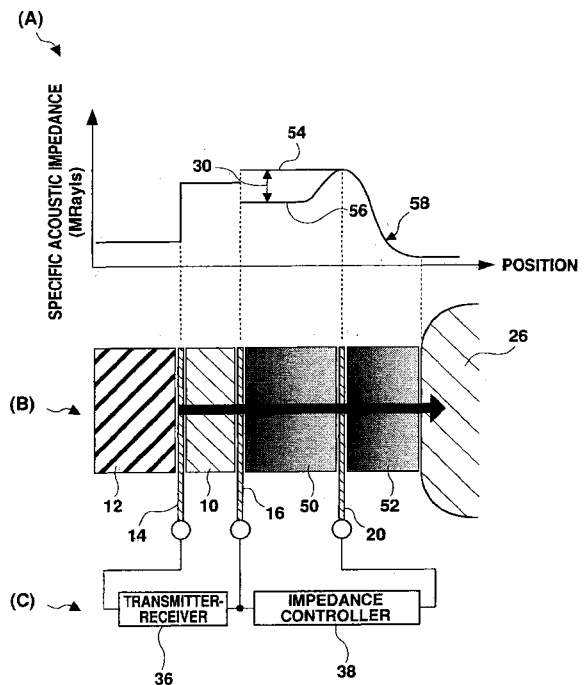

**Fig. 1**

**EP 1 901 280 A3**



EUROPEAN SEARCH REPORT

Application Number  
EP 07 02 4017

DOCUMENTS CONSIDERED TO BE RELEVANT			
Category	Citation of document with indication, where appropriate, of relevant passages	Relevant to claim	CLASSIFICATION OF THE APPLICATION (IPC)
X	US 5 974 884 A (SANO SHUZO [JP] ET AL) 2 November 1999 (1999-11-02)	1,5-9	INV. G10K11/02
Y	* column 5, line 45 - column 7, line 18;	2-4	
A	figure 1 *	10	
Y,D	----- JP 11 123188 A (ALOKA CO LTD) 11 May 1999 (1999-05-11) * abstract *	2-4	
A	----- EP 0 119 855 A2 (MATSUSHITA ELECTRIC IND CO LTD [JP]) 26 September 1984 (1984-09-26) * abstract *	1,10	
A	----- US 3 663 842 A (MILLER DARROW L) 16 May 1972 (1972-05-16) * column 1, line 69 - column 2, line 39 *	1,10	
A	----- EP 0 629 993 A2 (HEWLETT PACKARD CO [US]) 21 December 1994 (1994-12-21) * abstract *	1,10	TECHNICAL FIELDS SEARCHED (IPC)
			G10K
The present search report has been drawn up for all claims			
Place of search		Date of completion of the search	Examiner
The Hague		16 November 2010	Lorne, Benoît
CATEGORY OF CITED DOCUMENTS			
X : particularly relevant if taken alone		T : theory or principle underlying the invention	
Y : particularly relevant if combined with another document of the same category		E : earlier patent document, but published on, or after the filing date	
A : technological background		D : document cited in the application	
O : non-written disclosure		L : document cited for other reasons	
P : intermediate document		..... & : member of the same patent family, corresponding document	

1  
EPO FORM 1503 03/82 (P04C01)

ANNEX TO THE EUROPEAN SEARCH REPORT  
ON EUROPEAN PATENT APPLICATION NO.

EP 07 02 4017

This annex lists the patent family members relating to the patent documents cited in the above-mentioned European search report. The members are as contained in the European Patent Office EDP file on  
The European Patent Office is in no way liable for these particulars which are merely given for the purpose of information.

16-11-2010

Patent document cited in search report		Publication date	Patent family member(s)	Publication date
US 5974884	A	02-11-1999	JP 3964508 B2 JP 11089835 A	22-08-2007 06-04-1999
JP 11123188	A	11-05-1999	JP 3659780 B2	15-06-2005
EP 0119855	A2	26-09-1984	DE 3478357 D1 US 4523122 A	29-06-1989 11-06-1985
US 3663842	A	16-05-1972	NONE	
EP 0629993	A2	21-12-1994	JP 7030998 A US 5434827 A US 5438554 A	31-01-1995 18-07-1995 01-08-1995

专利名称(译)	超声波探头		
公开(公告)号	<a href="#">EP1901280A3</a>	公开(公告)日	2010-12-29
申请号	EP2007024017	申请日	2002-03-19
[标]申请(专利权)人(译)	日立阿洛卡医疗株式会社		
申请(专利权)人(译)	ALOKA CO. , LTD.		
当前申请(专利权)人(译)	日立ALOKA MEDICAL. , LTD.		
[标]发明人	SATO SHOHEI		
发明人	SATO, SHOHEI		
IPC分类号	G10K11/02 A61B8/00 H04R1/34 H04R17/00		
CPC分类号	G10K11/02 A61B8/4494		
优先权	2001298372 2001-09-27 JP		
其他公开文献	EP1901280A2		
外部链接	<a href="#">Espacenet</a>		

摘要(译)

用于超声诊断的超声探头包括换能器元件，声速控制元件和声匹配层。声速控制元件具有控制穿过其中的超声波的声速的功能，并且具有声速控制效果的倾斜特性，其中声速控制效果沿着超声波的行进方向连续变化（厚度方向）。在生物体附近的末端的声速控制元件的特定声阻抗对应于远离活体的末端的声匹配层的特定声阻抗。声匹配层优选地通过层叠2个或3个或更多个重叠构件而形成。两个相邻构件之间的边界具有多个山丘和山谷的形状。设定超声波的行进方向与边界之间的交叉角，以满足预定条件。

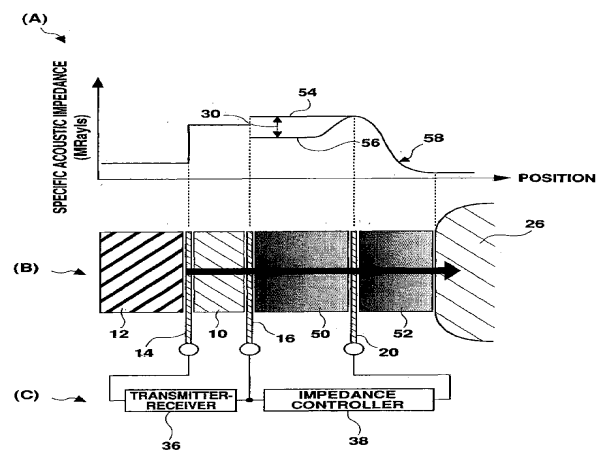

Fig. 1