



(12) **EUROPEAN PATENT APPLICATION**

(88) Date of publication A3:
01.12.2004 Bulletin 2004/49

(51) Int Cl.7: **G10K 11/02**

(43) Date of publication A2:
02.04.2003 Bulletin 2003/14

(21) Application number: **02006207.1**

(22) Date of filing: **19.03.2002**

(84) Designated Contracting States:
**AT BE CH CY DE DK ES FI FR GB GR IE IT LI LU
 MC NL PT SE TR**
 Designated Extension States:
AL LT LV MK RO SI

(72) Inventor: **Sato, Shohei**
Mitaka-shi, Tokyo, 181-8622 (JP)

(30) Priority: **27.09.2001 JP 2001298372**

(74) Representative: **Heim, Hans-Karl, Dipl.-Ing. et al**
Weber & Heim
Patentanwälte
Irmgardstrasse 3
81479 München (DE)

(71) Applicant: **ALOKA CO., LTD.**
Mitaka-shi Tokyo 181-8622 (JP)

(54) **Ultrasonic probe containing an element for controlling the sonic speed**

(57) An ultrasonic probe which is used for ultrasonic diagnosis comprises a transducer element, a sonic speed control element, and an acoustic matching layer. The sonic speed control element has a function to control the sonic speed of the ultrasonic waves traveling therethrough, and has an inclined characteristic in the sonic speed control effect in which the sonic speed control effect changes continuously along the direction of travel of the ultrasonic waves (thickness direction). The specific acoustic impedance of the sonic speed control element at the end near the living body corresponds to the specific acoustic impedance of the acoustic matching layer at the end away from the living body. The acoustic matching layer is preferably formed by layering 2 or 3 or more overlapped members. The boundary between two adjacent members has a shape with a plurality of hills and valleys. The crossing angle between the direction of travel of the ultrasonic waves and the boundary is set so that a predetermined condition is satisfied.

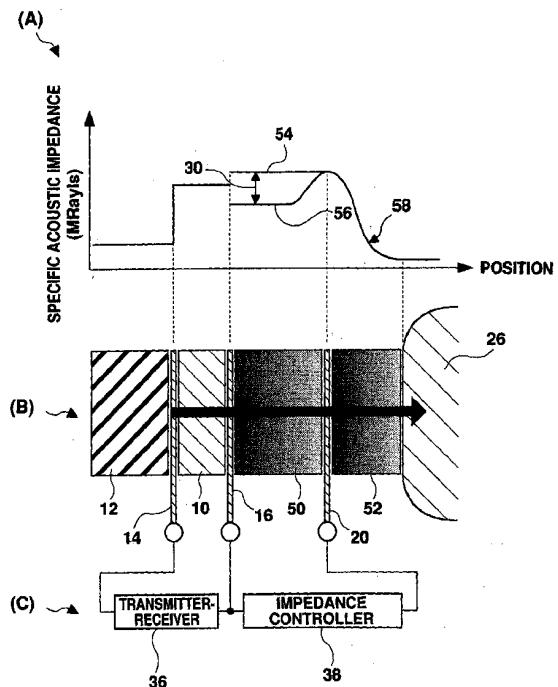

Fig. 1



European Patent
Office

EUROPEAN SEARCH REPORT

Application Number
EP 02 00 6207

DOCUMENTS CONSIDERED TO BE RELEVANT			
Category	Citation of document with indication of relevant passages	Relevant to claim	CLASSIFICATION OF THE APPLICATION (Int.Cl.7)
D, Y	PATENT ABSTRACTS OF JAPAN vol. 1999, no. 10, 31 August 1999 (1999-08-31) & JP 11 123188 A (ALOKA CO LTD), 11 May 1999 (1999-05-11)	15, 25	G10K11/02
A	* abstract *	1, 14	
Y	US 4 523 122 A (TONE MASAYUKI ET AL) 11 June 1985 (1985-06-11) * column 3, line 61 - line 68 * * column 7, line 43 - column 8, line 15 *	15, 25	
A	US 3 663 842 A (MILLER DARROW L) 16 May 1972 (1972-05-16) * column 1, line 69 - column 2, line 39 *	1, 14, 15, 25	
A	PATENT ABSTRACTS OF JAPAN vol. 0090, no. 27 (E-294), 6 February 1985 (1985-02-06) & JP 59 171295 A (MATSUSHITA DENKI SANGYO KK), 27 September 1984 (1984-09-27) * abstract *	1, 14, 15, 25	
A	US 5 438 554 A (SEYED-BOLORFOROSH MIR S ET AL) 1 August 1995 (1995-08-01) * column 2, line 5 - line 20 * * column 3, line 45 - line 68; claim 1 *	1, 14, 15, 25	TECHNICAL FIELDS SEARCHED (Int.Cl.7) G10K
The present search report has been drawn up for all claims			
Place of search The Hague		Date of completion of the search 12 October 2004	Examiner Lorne, B
CATEGORY OF CITED DOCUMENTS X : particularly relevant if taken alone Y : particularly relevant if combined with another document of the same category A : technological background O : non-written disclosure P : intermediate document		T : theory or principle underlying the invention E : earlier patent document, but published on, or after the filing date D : document cited in the application L : document cited for other reasons ----- & : member of the same patent family, corresponding document	

EPO FORM 1503 03/82 (P04C01)

**ANNEX TO THE EUROPEAN SEARCH REPORT
ON EUROPEAN PATENT APPLICATION NO.**

EP 02 00 6207

This annex lists the patent family members relating to the patent documents cited in the above-mentioned European search report. The members are as contained in the European Patent Office EDP file on
The European Patent Office is in no way liable for these particulars which are merely given for the purpose of information.

12-10-2004

Patent document cited in search report		Publication date	Patent family member(s)	Publication date
JP 11123188	A	11-05-1999	NONE	

US 4523122	A	11-06-1985	JP 1003119 B	19-01-1989
			JP 1519843 C	29-09-1989
			JP 59171295 A	27-09-1984
			JP 1003120 B	19-01-1989
			JP 1519844 C	29-09-1989
			JP 59171296 A	27-09-1984
			JP 1859913 C	27-07-1994
			JP 5068160 B	28-09-1993
			JP 60100070 A	03-06-1985
			DE 3478357 D1	29-06-1989
			EP 0119855 A2	26-09-1984

US 3663842	A	16-05-1972	NONE	

JP 59171295	A	27-09-1984	JP 1003119 B	19-01-1989
			JP 1519843 C	29-09-1989
			DE 3478357 D1	29-06-1989
			EP 0119855 A2	26-09-1984
			US 4523122 A	11-06-1985

US 5438554	A	01-08-1995	US 5434827 A	18-07-1995
			US 5465725 A	14-11-1995
			EP 0629993 A2	21-12-1994
			JP 7030998 A	31-01-1995
			US 5553035 A	03-09-1996

专利名称(译)	超声波探头包含用于控制声速的元件		
公开(公告)号	EP1298642A3	公开(公告)日	2004-12-01
申请号	EP2002006207	申请日	2002-03-19
[标]申请(专利权)人(译)	日立阿洛卡医疗株式会社		
申请(专利权)人(译)	ALOKA CO. , LTD.		
当前申请(专利权)人(译)	ALOKA CO. , LTD.		
[标]发明人	SATO SHOHEI		
发明人	SATO, SHOHEI		
IPC分类号	A61B8/00 G10K11/02 H04R1/34 H04R17/00		
CPC分类号	G10K11/02 A61B8/4494		
优先权	2001298372 2001-09-27 JP		
其他公开文献	EP1298642A2 EP1298642B1		
外部链接	Espacenet		

摘要(译)

用于超声诊断的超声探头包括换能器元件，声速控制元件和声匹配层。声速控制元件具有控制穿过其中的超声波的声速的功能，并且具有声速控制效果的倾斜特性，其中声速控制效果沿着超声波的行进方向连续变化（厚度方向）。声速控制元件在活体附近的端部处的特定声阻抗对应于远离活体的端部处的声匹配层的特定声阻抗。声匹配层优选地通过层叠2个或3个或更多个重叠构件而形成。两个相邻构件之间的边界具有多个山丘和山谷的形状。设定超声波的行进方向与边界之间的交叉角，以满足预定条件。

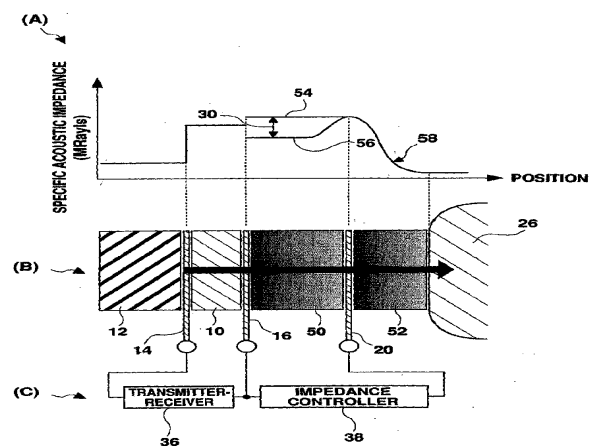

Fig. 1