



- (51) **International Patent Classification:**
A61B 8/08 (2006.01)
- (21) **International Application Number:**
PCT/IB2011/054587
- (22) **International Filing Date:**
17 October 2011 (17.10.2011)
- (25) **Filing Language:** English
- (26) **Publication Language:** English
- (30) **Priority Data:**
10188040.9 19 October 2010 (19.10.2010) EP
- (71) **Applicant (for all designated States except US):** KONINKLIJKE PHILIPS ELECTRONICS N.V. [NL/NL]; Groenewoudseweg 1, NL-5621 BA Eindhoven (NL).
- (72) **Inventors; and**
- (75) **Inventors/Applicants (for US only):** MITTAL, Chetan [IN/IN]; c/o Philips Electronics India Ltd., Manyata Tech Park, Nagavara, Bangalore 560045 (IN). RAJU, Balasundar, Iyyavu [IN/US]; 345 Scarborough Road, Briarcliff Manor, New York 10510 (US).
- (74) **Agents:** VAN VELZEN, Maaïke, M. et al.; High Tech Campus, Building 44, NL-5600 AE Eindhoven (NL).
- (81) **Designated States (unless otherwise indicated, for every kind of national protection available):** AE, AG, AL, AM, AO, AT, AU, AZ, BA, BB, BG, BH, BR, BW, BY, BZ, CA, CH, CL, CN, CO, CR, CU, CZ, DE, DK, DM, DO, DZ, EC, EE, EG, ES, FI, GB, GD, GE, GH, GM, GT, HN, HR, HU, ID, IL, IN, IS, JP, KE, KG, KM, KN, KP, KR, KZ, LA, LC, LK, LR, LS, LT, LU, LY, MA, MD, ME, MG, MK, MN, MW, MX, MY, MZ, NA, NG, NI, NO, NZ, OM, PE, PG, PH, PL, PT, QA, RO, RS, RU, RW, SC, SD, SE, SG, SK, SL, SM, ST, SV, SY, TH, TJ, TM, TN, TR, TT, TZ, UA, UG, US, UZ, VC, VN, ZA, ZM, ZW.
- (84) **Designated States (unless otherwise indicated, for every kind of regional protection available):** ARIPO (BW, GH, GM, KE, LR, LS, MW, MZ, NA, RW, SD, SL, SZ, TZ, UG, ZM, ZW), Eurasian (AM, AZ, BY, KG, KZ, MD, RU, TJ, TM), European (AL, AT, BE, BG, CH, CY, CZ, DE, DK, EE, ES, FI, FR, GB, GR, HR, HU, IE, IS, IT, LT, LU, LV, MC, MK, MT, NL, NO, PL, PT, RO, RS,

[Continued on next page]

(54) **Title:** DOPPLER ULTRASOUND BASED FETAL MONITORING

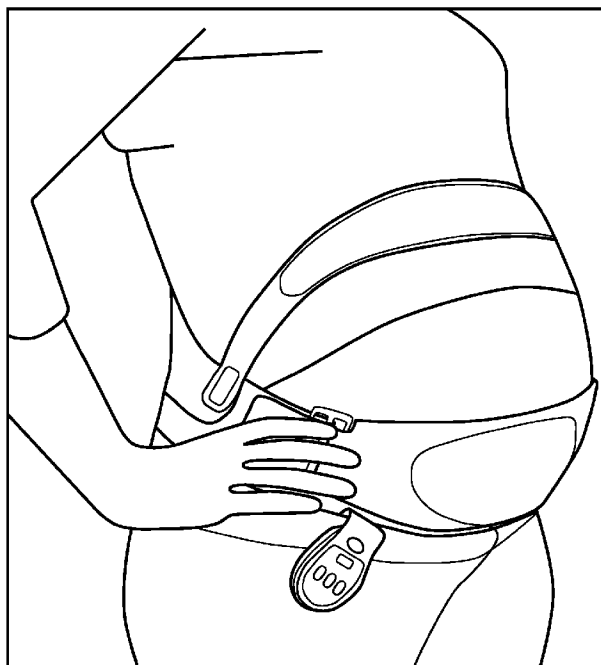

FIG. 3

(57) **Abstract:** A fetal movement monitoring method that limits the ultrasound radiation to safe levels and conforms to the ALARA principle is disclosed. The disclosed method of monitoring fetal movements by Doppler ultrasound comprises accumulating the time for which ultrasound is radiated into a subject, comparing the accumulated time with a first reference total time, counting the number of fetal movements in the subject, comparing the number of movements with a reference number, deciding at least one of a further action of the device and an action to be recommended to the subject and conveying at least one of a further action of the device, an information to the subject about the counted fetal movements and an action recommended to the subject. A Doppler ultrasound device for monitoring fetal movements in a subject is also disclosed.

SE, SI, SK, SM, TR), OAPI (BF, BJ, CF, CG, CI, CM, GA, GN, GQ, GW, ML, MR, NE, SN, TD, TG).

Published:

Declarations under Rule 4.17:

— *as to applicant's entitlement to apply for and be granted a patent (Rule 4.17(ii))*

— *with international search report (Art. 21(3))*

— *before the expiration of the time limit for amending the claims and to be republished in the event of receipt of amendments (Rule 48.2(h))*

Doppler ultrasound based fetal monitoring

FIELD OF THE INVENTION

The following belongs to the field of Doppler ultrasound and to the field of Doppler ultrasound based fetal monitoring.

5 BACKGROUND OF THE INVENTION

With advances in ultrasound technologies, ultrasound monitoring devices are increasingly available for home use. With this, the risk of exposure to doses of ultrasound higher than recommended is also increasing. Home ultrasound devices with automatic time out and those that measure the dosage and automatically lock themselves are known. The principle behind safe exposure to any radiation, in the present case to ultrasound radiation, is known as ALARA – As Low As Reasonably Achievable.

The published European patent application EP1852058A1 titled “Fetus Movement Monitoring System and Fetus Movement Information Collecting Device” describes a device for sensing fetal movements that uses a passive sensor. It states that in hospitals, the image of a fetus in the uterus of the mother's body is generally monitored by an ultrasonic wave echo device. But, because this type of device is a so-called active sensor type which applies an ultrasonic wave to a fetus in the uterus of the mother's body and receives its reflected wave, it is undesirable to use this type of device for monitoring fetal movements over a long time in consideration of an adverse influence to the fetus. Furthermore, there is a problem that an ultrasonic wave echo device is configured to be used by a specialist such as a doctor or midwife, and cannot be used easily by a pregnant woman herself at home.

Recent advances in ultrasound technologies have enabled the use of Doppler Ultrasound for fetal movement monitoring at home. However the danger of unintended exposure to ultrasound radiation beyond recommended doses still exists.

25 SUMMARY OF THE INVENTION

It is preferable to have a Doppler ultrasound device and method and a computer program to execute such a method, for fetal monitoring at home that limits the ultrasound dosage to the recommended maximum daily dosage. It is also preferable to have

such a device that also follows the ALARA principle and. The disclosed device and method are defined by the independent claims. The dependent claims define advantageous embodiments.

Such a Doppler ultrasound device for monitoring a fetus in a subject and
5 limiting ultrasound radiation to the fetus, comprises an estimator unit for estimating an adequacy of acoustic coupling between an ultrasound transducer and the subject, an accumulator unit for accumulating a time duration for which ultrasound is radiated into the subject, based on the estimate, a first comparison unit for comparing the accumulated time
10 duration with a reference time duration, a detector unit for detecting a movement of the fetus based on reflected ultrasound radiation, a counter unit for counting the number of detected fetal movements, a second comparison unit for comparing the number of counted fetal movements with a reference number, a decision unit for making at least one decision based on at least one of an output of the first comparator and an output of the second comparator;
15 and a user interface for conveying an information to the subject based on the at least one decision.

This device provides the advantage of being safe for use by the mother-to-be herself in the comfort of her home. It may further have the advantage of providing information about the movements of the fetus along with the information whether the movements are within the normal range or not. What is normal is based on available clinical
20 data on the number of fetal movements in a given time duration. It may have the further advantage that the method follows the 'ALARA' principle and is safe for the mother-to-be and the fetus and, at the same time, provides information about fetal movements.

A method of Doppler ultrasound limiting ultrasound radiation to a fetus in a subject while monitoring the fetus, is also disclosed herein, the method comprising the steps
25 of an estimation step of estimating acoustic coupling between an ultrasound transducer and the subject, an accumulation step of accumulating a time duration for which ultrasound is radiated into the subject, based on the estimation, a first comparison step of comparing the accumulated time duration with a first reference time duration, a detection step of detecting a movement of the fetus based on reflected ultrasound radiation, a counting step of counting
30 the number of detected fetal movements, a second comparison step of comparing the number of counted fetal movements with a reference number, a decision step of making at least one decision based on at least one of the first comparison and the second comparison and a conveying step of conveying an information to the subject based on the decision.

A computer program product is also disclosed. The program comprises computer executable instructions for carrying out the disclosed method when the computer program is run on a computer.

5 A computer readable storage medium in which the disclosed computer program is stored is also disclosed.

BRIEF DESCRIPTION OF THE DRAWINGS

These and other aspects will be described in detail, by way of example, on the basis of the following embodiments and implementations, with reference to the
10 accompanying drawings, wherein:

Fig. 1 is a diagrammatic representation of the device disclosed

Fig. 2 is a table showing the functional details of the device disclosed;

Fig. 3 is a diagrammatic representation of an embodiment of the disclosed
device; and

15 Fig. 4 is a diagrammatic representation of the method disclosed;

DETAILED DESCRIPTION OF EMBODIMENTS

The disclosed device and method are described below in detail with reference
to the figures.

20 With reference to Fig. 1, a Doppler ultrasound device 100 for assessing wellbeing of a fetus in a subject based on fetal movements is described. An ultrasound transducer 101 is used to radiate a subject with ultrasound of suitable characteristics and to receive the reflected ultrasound waves. The device comprises a estimator unit 103 for
estimating whether the acoustic coupling between the transducer and the subject (not shown)
25 is adequate or not. A accumulator unit 105 accumulates a time duration of ultrasound radiation. A first comparison unit 107 compares the accumulated time duration with a reference time duration. A detector unit 109 detects movements of the fetus based on
reflected ultrasound radiation. A counter unit 111 counts the number of fetal movements
30 detected by the detector unit 109. A second comparison unit 113 compares the number of counted fetal movements with a reference number. A decision unit 115 decides on at least one of a further action of the device, the assessed state of wellbeing of the fetus and an action recommended to the subject based on the comparison. A user interface 117 conveys the
decision or decisions of the decision unit to the subject. The user interface 117 may also be
used to convey to the user the estimate of the acoustic coupling from the estimation unit 103.

The various decisions and conditions under which those decisions are reached are now described. These conditions and decision are shown in tabular form in columns 1 to 5 of Fig. 2. If the number of counted movements reaches the reference number before the accumulated time duration for which ultrasound is radiated reaches the reference time duration, further counting of fetal movements is stopped. That is to say, ultrasound radiation is stopped and further ultrasound radiation is disabled for a predetermined time duration. This ensures that the exposure to ultrasound is limited according to the principle of ALARA. If the number of counted fetal movements does not reach the reference number before the accumulated time duration reaches the reference time duration, the following are done. The radiation of ultrasound and counting of the fetal movements is continued for a predefined extended time duration, say 30 minutes. The information that the fetal movement is being counted for the predefined extended time duration is conveyed to the subject. The counting is continued from the number that was reached when the reference time duration was reached. Whenever the number of counted fetal movements reaches the reference number at any time within the predefined extended time duration, it is conveyed to the subject that the number of fetal movements is within normal limits and further ultrasound radiation is disabled for the predetermined time duration. And if the number of counted fetal movements does not reach the reference number even at the end of the predefined extended time duration, the information is conveyed to the subject that the reference number has not been reached and the subject is recommended to consult a medical practitioner at the earliest and further ultrasound radiation is disabled for the predetermined time duration.

In an extreme case where not a single movement of the fetus is recorded when the accumulated time duration has reached the reference time duration, further radiation is disabled for the predetermined time duration and it is recommended to the subject to consult a medical practitioner at the earliest.

As described earlier, accumulator unit 105 starts accumulating the time duration of ultrasound radiation only when the estimator unit 103 has estimated that the acoustic coupling is adequate. Since the ultrasound transducer should be coupled adequately to the surface of the subject's abdomen, and an adequate amount of a gel between the surface of the abdomen and the transducer is needed to ensure adequate acoustic coupling, there are chances that the acoustic coupling is not adequate. Methods to determine whether the acoustic coupling is adequate or not, are known. They may utilize detection of ringing in the transducer when the acoustic coupling is inadequate, for instance.

Even though, in the description above, the time is said to be accumulated upwards, it is obvious that time can be counted downwards and when the remaining time reaches zero it is equivalent to the output of the first comparator indicating that the reference time duration has elapsed. The remaining time being greater than zero, conversely, is
5 equivalent to the comparator indicating that the reference time duration has not elapsed. Thus the description is only to describe the method in an easily understandable manner. There may be many different ways of achieving the desired result and all such equivalent variations are assumed to fall under the scope of the disclosed method.

The conditions under which various actions are taken by the device, the
10 indications to be conveyed to the subject and the recommendations to be made to the subject are listed in tabular form in Fig. 2. In this table, under the first two columns, the comparator output '1' means that the value of the corresponding compared quantity has reached or crossed the reference values of the respective comparators. Conversely the comparator output '0' indicates that the compared quantity is below the reference value. It is evident that this is
15 only one way of describing the outputs and what is meant is a binary logical output.

The sixth column of the table in Fig. 2 shows the recommendations to be made to the subject under the various conditions described hitherto. The sixth column of Fig. 2 shows one of the exemplary ways of conveying information to the subject. Colored lights, LEDs for instance, are used to indicate various conditions and recommendations. However,
20 other means of conveying information and recommendations to the subject could be thought of, for instance LED or LCD alphanumeric display units, for instance.

The disclosed device thus gives the subject information and recommends action to ensure the safety of the fetus and the subject. At the same time, it ensure that the subject cannot use the device further with the hope that if monitored further, the device may
25 detect fetal movements and thereby wasting precious time in consulting a medical practitioner and/or endangering the subject and the fetus with radiation beyond the recommended maximum daily dosage.

In the description above, the reference number has been treated as a constant. However, it is known that as the pregnancy advances, the number of movements of the fetus per day, and hence the number of movements in the predetermined time duration tends to
30 fall. Thus, the reference number reduces as the age of the pregnancy increases. The reference numbers may be updated as the age of the pregnancy increases. Reference numbers may be stored in a look up table, for instance, mapped to the age of the pregnancy and the reference number updated every time the device is used by the subject. Alternatively the reference

number may be updated every week, once the age of the pregnancy has been entered at the time of the first use of the device.

It is contemplated that the disclosed device is in the form of or comprises or adapted into a belt as shown in Fig. 3, which when worn around the waist or abdomen of the subject, positions the ultrasound transducer 315 on the surface of the subject's abdomen. However, the subject may have to ensure that gel is applied at the right place so that there is adequate acoustic coupling between the transducer and the subject. With this the subject can go about her work while the device is in operation.

Fig. 4 is a diagrammatic representation of the disclosed method of Doppler ultrasound. It is known that ultrasound is radiated into a subject and the reflected waves are received and analyzed for imaging the part of the subject's body that reflects the ultrasound. If there are parts of the body that are moving inside the patient's body, the reflected ultrasound will have a shift in its frequency depending on the speed and direction of the movement of the part of the body. Such a shift is known as the Doppler shift. An analysis of the shift in the frequency, the Doppler shift, of the reflected ultrasound provides information on the movement of the parts of the subject's body.

According to the disclosed method 400, the abdomen of the subject is radiated with ultrasound and it is ascertained that the acoustic coupling between the ultrasound transducer and the abdomen of the subject is adequate in an estimation step 419. The duration of ultrasound radiation is measured and accumulated in an accumulation step 421 only when the estimate is that the acoustic coupling is adequate. This estimation is carried out periodically to ensure that the acoustic coupling remains adequate throughout the duration of the assessment. If the acoustic coupling is estimated to be inadequate at any time, the accumulation is stopped. It is continued only after the acoustic coupling has been set right.

The accumulated time duration is compared with a reference time duration, one hour for instance, in a first comparison step 423. Simultaneously, the reflected ultrasound is received and analyzed to detect fetal movements in a detection step 425. The fetal movements sensed are counted in a counting step 427. The number of counted fetal movements is compared in a comparison step 429 with a reference number. Based on the results of the two comparisons, a decision is made in a decision making step 431. One of the decisions is whether to continue the process or not. The other decision is an estimate about the wellbeing of the fetus based on the number of counted fetal movements. One or more of these may be conveyed to the subject in a conveying step 433.

When this method is employed on a pregnant woman, with appropriate choice of the frequency of the ultrasound and the application of the ultrasound to the abdomen, information about the movements of the fetus may be obtained. This information may be about movements of the fetus, fetal heartbeat, maternal heartbeat blood flow in maternal or fetal blood vessels or both for instance.

Since the characteristics of the fetal movements are known, the signals corresponding to them can be recognized and counted. Although there are variations in the number of fetal movements from one mother-to-be to another, data on such movements collected over a large number of pregnant women has shown the normal evolution of the number of fetal movements over the gestation period. The trend of movements in a pregnancy is therefore relevant and any decrease of movements more than expected from the normal trend over the gestation period may be indicative of fetal compromise. Thus these movements may be counted to assess if the number of fetal movements in a given time duration is within the normal range or not.

However, if the number of fetal movements is below the normal count but is close to it, an ambiguity exists since the number of fetal movements is not uniform over the day. In such cases, the monitoring of the subject for fetal movements for an extended time is recommended. However, it is not recommended that the subject and the fetus be exposed to ultrasound over long periods of time. A method of Doppler ultrasound based fetal movement monitoring that avoids such exposure beyond the recommended dosage and still provides useful information about the fetal movement is disclosed.

A computer program product is also disclosed. Such a computer program product comprises computer executable instructions for carrying out the method disclosed herein, when the computer program is run on a computer. The computer program has computer executable instructions to carry out the various steps of the disclosed method. The term computer is used in a general sense. This could be any of the various digital circuits such as a microprocessor, microcontroller, a Digital Signal Processor (DSP) or any other dedicated or generally purpose electronic component with computing ability.

Computer readable media carrying the disclosed computer program is also disclosed. Such a computer program may be burnt or otherwise stored in computer readable media such as a CD, DVD, or a plug-in semiconductor memory device commonly called a USB device. The program may be made available on the internet for download and installed on the disclosed device before using the device. Such a program has all the necessary computer executable instructions to carry out the method either on a dedicated device such as

the one disclosed above or on a general purpose Ultrasound device that could run the said program to carry out the various steps of the method disclosed.

5 While the embodiments and implementations have been described in detail in the drawings and description, such drawings and description are to be considered exemplary and not restrictive; the invention is not limited to the disclosed embodiments. Variations and combinations will occur to a practitioner and all such variations are deemed to be within the scope of the disclosed methods.

10 In the descriptions above, since the device and method are for use by a pregnant lady for monitoring herself, the term subject has been used everywhere. However it is conceivable that someone else may assist the lady and in that case, the information conveyed may be for that person. This however does not affect the descriptions in a significant manner.

15 Other variations to the disclosed embodiments can be understood and effected by those skilled in the art, in practicing the claimed invention, from a study of the drawings, the disclosure, and the appended claims. In the claims, the word "comprising" does not exclude elements or steps other than those mentioned, and the indefinite article "a" or "an" does not exclude a plurality. A single processor or other unit may fulfill the functions of several items recited in the claims. The mere fact that certain measures are recited in mutually different dependent claims does not indicate that a combination of these measures cannot be used to advantage. A computer program may be stored or distributed on a suitable medium, such as an optical storage medium or a solid-state medium supplied together with or 20 as part of other hardware, but may also be distributed in other forms, such as via the Internet or other wired or wireless telecommunication systems. Any reference signs in the claims should not be construed as limiting the scope of the claims.

CLAIMS:

1. A Doppler ultrasound device (100) for monitoring a fetus in a subject and limiting ultrasound radiation to the fetus, the device comprising:
 - an estimator unit (103) for estimating an adequacy of acoustic coupling between an ultrasound transducer and the subject;
 - 5 an accumulator unit (105) for accumulating a time duration for which ultrasound is radiated into the subject, based on the estimate;
 - a first comparison unit (107) for comparing the accumulated time duration with a reference time duration;
 - 10 a detector unit (109) for detecting a movement of the fetus based on reflected ultrasound radiation;
 - a counter unit (111) for counting the number of detected fetal movements;
 - a second comparison unit (113) for comparing the number of counted fetal movements with a reference number;
 - 15 a decision unit (115) for making at least one decision based on at least one of an output of the first comparator and an output of the second comparator; and
 - a user interface (117) for conveying an information to the subject based on the at least one decision.
- 20 2. The device of claim 1 wherein the device is adapted for being operational when worn on the subject's abdomen.
3. The device of claim 1 wherein the counter unit (111) is for counting fetal movements above a predefined threshold of at least one parameter of the movement of the fetus out of a set of parameters including but not limited to a magnitude, a velocity, an
25 acceleration and a force.
4. The device of claim 1 wherein the reference number is dependent on an age of the pregnancy of the subject.

5. The device of claim 1 wherein:
when the accumulated time duration is less than the reference time duration and the number of counted fetal movements is less than the reference number, the decision of the decision unit (115) is to continue the accumulating and the counting; and
5 the user interface (117) conveys to the user that the assessing is continuing.

6. The device of claim 1 wherein:
when the accumulated time duration is less than the reference time duration and the number of counted fetal movements equals the reference number, the decision of the
10 decision unit (115) is to disable the ultrasound radiation for a predetermined time duration;
and
the user interface (117) conveys to the subject that the movement count is normal.

15 7. The device of claim 1 wherein:
when the accumulated time duration is equal to the reference time duration and the number of counted fetal movements is zero, the decision of the decision unit (115) is to disable the ultrasound radiation for the predetermined time duration; and
the user interface (117) conveys a recommendation to the subject.

20 8. The device of claim 1 wherein:
when the accumulated time duration is equal to the reference time duration and the number of counted fetal movements is less than the reference number and not zero, the decision of the decision unit (115) is to continue the accumulating and the counting for a
25 predefined extended time duration; and
the user interface (117) conveys to the user that the ultrasound radiation is being continued for the predefined extended time duration.

30 9. The device of claim 1 wherein:
when the accumulated time duration is equal to the sum of the first reference time duration and the predefined extended time duration, and the number of counted fetal movements is less than the reference number, the decision of the decision unit (115) is to disable the ultrasound radiation for the predetermined time duration; and
the user interface (117) conveys a recommendation to the subject.

10. The device of claim 1 wherein:

when the accumulated time duration is less than the sum of the first reference time duration and the predefined extended time duration, and the number of counted fetal movements is equal to the reference number, the decision of the decision unit (115) is to disable the ultrasound radiation for the predetermined time duration and user interface (117) conveys to the subject that the number of fetal movements is normal; or

when the accumulated time duration is equal to the sum of the first reference time duration and the predefined extended time duration, and the number of counted fetal movements is less than the reference number, the decision of the decision unit (115) is to disable the ultrasound radiation for the predetermined time duration and the user interface (117) conveys a recommendation to the subject.

11. The device of claim 1 further comprising a memory unit for storing the number of counted fetal movements; and

the decision unit is configured for making a decision based on the number of counted fetal movements at the end of an assessment and the number of counted fetal movements at the end of the preceding assessment.

12. The device of claim 11 configured to additionally store the accumulated time duration at the end of an assessment; and

the decision unit is configured for making a decision based on a ratio of counted fetal movements at the end of an assessment and the accumulated time duration at the end of the assessment and the ratio of counted fetal movements at the end of the preceding assessment and the accumulated time duration at the end of the preceding assessment.

13. A method of limiting ultrasound radiation to a fetus in a subject while monitoring the fetus, the method comprising the steps of:

an estimation step of estimating acoustic coupling between an ultrasound transducer and the subject;

an accumulation step of accumulating a time duration for which ultrasound is radiated into the subject, based on the estimation;

a first comparison step of comparing the accumulated time duration with a

first reference time duration;

a detection step of detecting a movement of the fetus based on reflected ultrasound radiation;

a counting step of counting the number of detected fetal movements;

5 a second comparison step of comparing the number of counted fetal movements with a reference number;

a decision step of making at least one decision based on at least one of the first comparison and the second comparison; and

10 a conveying step of conveying an information to the subject based on the decision.

14. A computer program product comprising computer executable instructions for carrying out the method of claim 13 when the computer program is run on a computer.

15 15. A computer readable storage medium carrying the computer program according to claim 14.

1/4

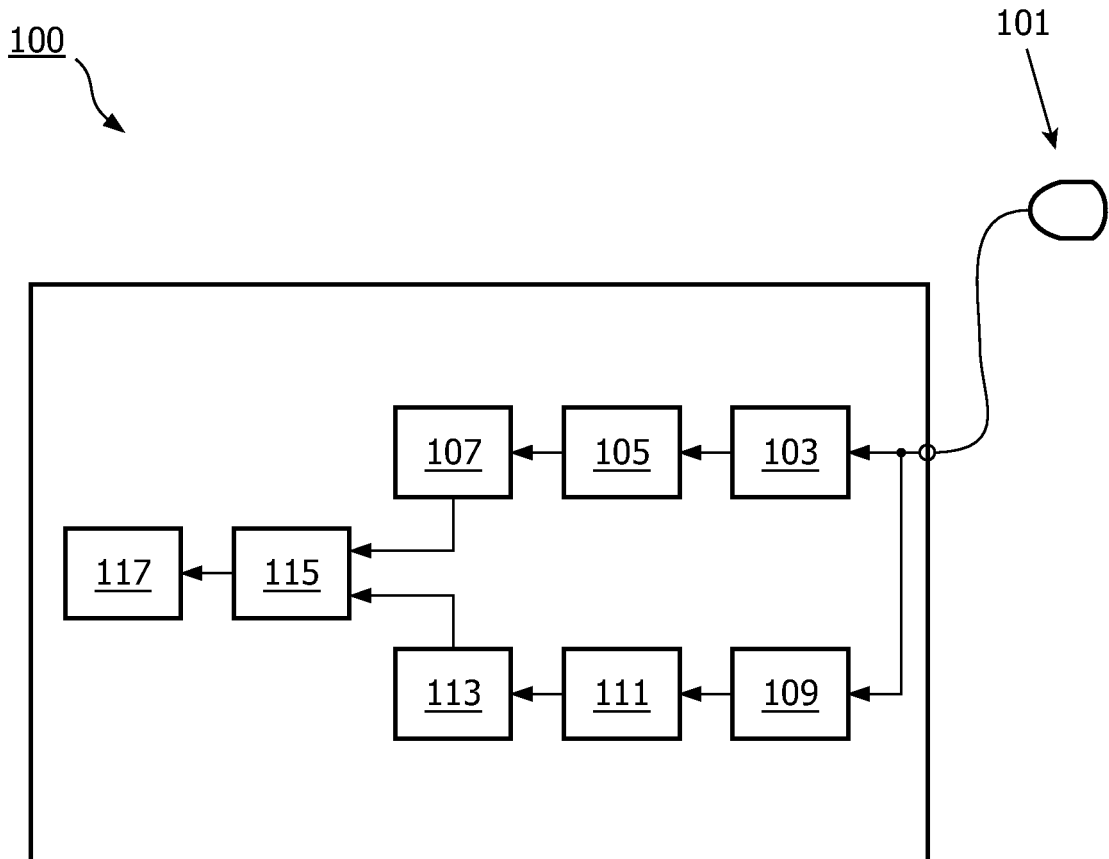

FIG. 1

Col. 1	Col. 2	Col. 3	Col. 4	Col. 5	Col. 6	Col. 7
Result of the first comparison (accumulated time < reference time > 0)	Result of the second comparison (COUNT* < reference count > 0)	Further action	Count normal or not	Recommendations to the subject	Example indication with a light source. For instance colored LED	Status of the device to be indicated to the subject
0	0	Continue counting movements	None	None	Blue/white	In use within first time slot
0	1	Stop US radiation and counting of movements	Normal	None	Green	Stopped
1	0 (COUNT ≥ 1)	Continue count	None	None	Amber	In extended time period
1	0 (COUNT = 0)	Stop counting movements	No fetal movement	Consult doctor	Red	Stopped
1	1	Stop counting	Normal	None	Green	Stopped
In the extended time period						
(accumulated time < (reference time + extended time) > 0)						
0	1	Stop counting movements	Normal	None	Green	Stopped
1	0	Stop counting movements	Fetal movement count below normal	Consult your doctor immediately	Red	Stopped
1	0	Stop counting	Normal	None	Green	Stopped

*: COUNT = Counted number of movements

FIG. 2

3/4

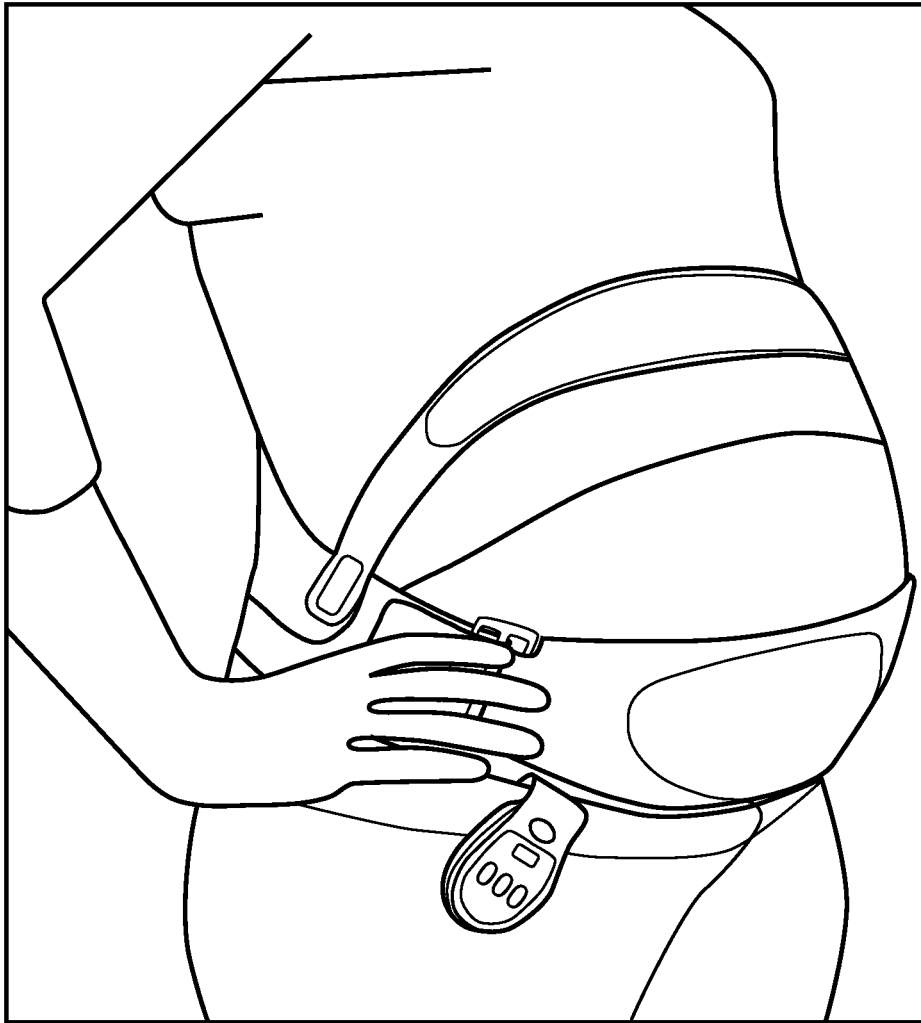

FIG. 3

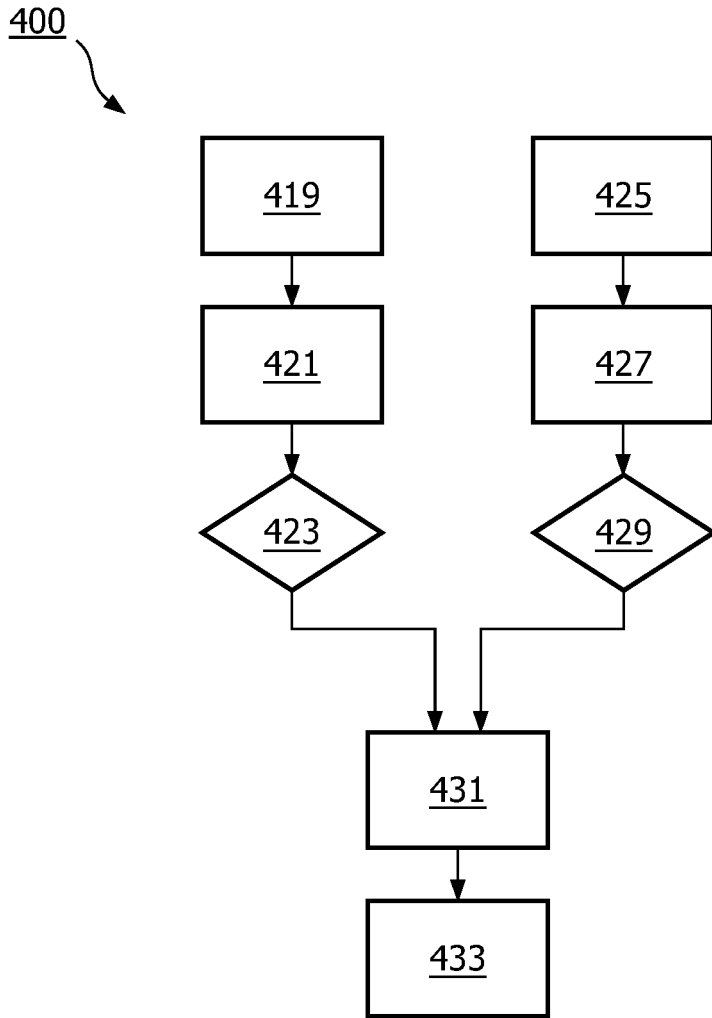

FIG. 4

INTERNATIONAL SEARCH REPORT

International application No PCT/IB2011/054587
--

A. CLASSIFICATION OF SUBJECT MATTER INV. A61B8/08 ADD.				
According to International Patent Classification (IPC) or to both national classification and IPC				
B. FIELDS SEARCHED Minimum documentation searched (classification system followed by classification symbols) A61B				
Documentation searched other than minimum documentation to the extent that such documents are included in the fields searched				
Electronic data base consulted during the international search (name of data base and, where practical, search terms used) EPO-Internal, WPI Data				
C. DOCUMENTS CONSIDERED TO BE RELEVANT				
Category*	Citation of document, with indication, where appropriate, of the relevant passages	Relevant to claim No.		
A	KARLSSON B ET AL: "The DopFet system: a new ultrasonic Doppler system for monitoring and characterization of fetal movement", ULTRASOUND IN MEDICINE AND BIOLOGY, NEW YORK, NY, US, vol. 26, no. 7, 1 September 2000 (2000-09-01), pages 1117-1124, XP004295647, ISSN: 0301-5629, DOI: 10.1016/S0301-5629(00)00253-2 the whole document	1-15		
A	WO 93/18710 A1 (HEMOCARE DIAGNOSTIC SERVICES [US]) 30 September 1993 (1993-09-30) abstract figure 1	1-15		

-/--				
<table style="width: 100%; border: none;"> <tr> <td style="width: 50%; border: none;"><input checked="" type="checkbox"/> Further documents are listed in the continuation of Box C.</td> <td style="width: 50%; border: none;"><input checked="" type="checkbox"/> See patent family annex.</td> </tr> </table>			<input checked="" type="checkbox"/> Further documents are listed in the continuation of Box C.	<input checked="" type="checkbox"/> See patent family annex.
<input checked="" type="checkbox"/> Further documents are listed in the continuation of Box C.	<input checked="" type="checkbox"/> See patent family annex.			
* Special categories of cited documents :				
"A" document defining the general state of the art which is not considered to be of particular relevance "E" earlier document but published on or after the international filing date "L" document which may throw doubts on priority claim(s) or which is cited to establish the publication date of another citation or other special reason (as specified) "O" document referring to an oral disclosure, use, exhibition or other means "P" document published prior to the international filing date but later than the priority date claimed		"T" later document published after the international filing date or priority date and not in conflict with the application but cited to understand the principle or theory underlying the invention "X" document of particular relevance; the claimed invention cannot be considered novel or cannot be considered to involve an inventive step when the document is taken alone "Y" document of particular relevance; the claimed invention cannot be considered to involve an inventive step when the document is combined with one or more other such documents, such combination being obvious to a person skilled in the art. "&" document member of the same patent family		
Date of the actual completion of the international search	Date of mailing of the international search report			
22 February 2012	02/03/2012			
Name and mailing address of the ISA/ European Patent Office, P.B. 5818 Patentlaan 2 NL - 2280 HV Rijswijk Tel. (+31-70) 340-2040, Fax: (+31-70) 340-3016	Authorized officer Willig, Hendrik			

INTERNATIONAL SEARCH REPORT

International application No

PCT/IB2011/054587

C(Continuation). DOCUMENTS CONSIDERED TO BE RELEVANT		
Category*	Citation of document, with indication, where appropriate, of the relevant passages	Relevant to claim No.
A	FR 2 602 413 A1 (COLETTE CLAUDE [FR]) 12 February 1988 (1988-02-12) abstract	1-15
A	----- WHEELER T ET AL: "Detection of fetal movement using Doppler ultrasound", OBSTETRICS AND GYNECOLOGY, LIPPINCOTT WILLIAMS & WILKINS, US, vol. 70, no. 2, 1 August 1987 (1987-08-01) , pages 251-254, XP009156750, ISSN: 0029-7844 the whole document	1-15
A,P	----- EIJI RYO ET AL: "A new method for long-term home monitoring of fetal movement by pregnant women themselves", MEDICAL ENGINEERING & PHYSICS, 1 October 2011 (2011-10-01), XP55019879, ISSN: 1350-4533, DOI: 10.1016/j.medengphy.2011.09.001 abstract	1-15
A,P	----- G. T. HAAR ET AL: "Ultrasonic imaging: safety considerations", INTERFACE FOCUS, vol. 1, no. 4, 6 August 2011 (2011-08-06), pages 686-697, XP55019905, ISSN: 2042-8898, DOI: 10.1098/rsfs.2011.0029 the whole document -----	1-15

INTERNATIONAL SEARCH REPORT

Information on patent family members

International application No
PCT/IB2011/054587

Patent document cited in search report	Publication date	Patent family member(s)	Publication date
WO 9318710	A1	AU 4044393 A WO 9318710 A1	21-10-1993 30-09-1993
FR 2602413	A1	NONE	

专利名称(译)	基于多普勒超声的胎儿监护		
公开(公告)号	EP2629672A1	公开(公告)日	2013-08-28
申请号	EP2011781636	申请日	2011-10-17
[标]申请(专利权)人(译)	皇家飞利浦电子股份有限公司		
申请(专利权)人(译)	皇家飞利浦电子N.V.		
当前申请(专利权)人(译)	皇家飞利浦电子N.V.		
[标]发明人	MITTAL CHETAN RAJU BALASUNDAR IYYAVU		
发明人	MITTAL, CHETAN RAJU, BALASUNDAR, IYYAVU		
IPC分类号	A61B8/08		
CPC分类号	A61B8/0866 A61B8/08 A61B8/4427 A61B8/46 A61B8/488 A61B8/54		
代理机构(译)	STEFFEN , THOMAS		
优先权	2010188040 2010-10-19 EP		
其他公开文献	EP2629672B1		
外部链接	Espacenet		

摘要(译)

公开了一种将超声辐射限制在安全水平并符合ALARA原理的胎动监测方法。所公开的通过多普勒超声监测胎儿运动的方法包括累积超声辐射到受试者中的时间，将累积时间与第一参考总时间进行比较，计算受试者中胎儿运动的数量，比较运动的数量与参考数字，决定设备的进一步动作和要向对象推荐的动作中的至少一个，并且传达设备的进一步动作中的至少一个，向受试者提供关于计数的胎动和动作的信息。推荐给主题。还公开了一种用于监测受试者中胎儿运动的多普勒超声装置。