

(19) World Intellectual Property
Organization
International Bureau



(43) International Publication Date
22 January 2004 (22.01.2004)

PCT

(10) International Publication Number
WO 2004/006773 A1

- (51) International Patent Classification⁷: **A61B 8/00 // 8/12**
- (21) International Application Number:
PCT/NO2002/000264
- (22) International Filing Date: 15 July 2002 (15.07.2002)
- (25) Filing Language: English
- (26) Publication Language: English
- (71) Applicant (for all designated States except US): **EAGLE ULTRASOUND AS** [NO/NO]; Innovasjonssenter Gløshaugen, Richard Birkelands vei 2G, N-7491 Trondheim (NO).
- (72) Inventors; and
- (75) Inventors/Applicants (for US only): **ANGELSEN, Bjørn, A., J.** [NO/NO]; Bugges veg 4B, N-7051 Trondheim (NO). **JOHANSEN, Tonni, F.** [NO/NO]; Osloveien 6, N-7018 Trondheim (NO). **KJØDE, Stig** [NO/NO]; Loholtbakken 1A, N-7049 Trondheim (NO).
- (74) Agent: **ABC-PATENT, SIVILING. ROLF CHR. B. LARSEN A.S.**; Postboks 6150 Etterstad, Brynsveien 5, N-0602 Oslo (NO).
- (81) Designated States (national): AE, AG, AL, AM, AT, AU, AZ, BA, BB, BG, BR, BY, BZ, CA, CH, CN, CO, CR, CU, CZ, DE, DK, DM, DZ, EC, EE, ES, FI, GB, GD, GE, GH, GM, HR, HU, ID, IL, IN, IS, JP, KE, KG, KP, KR, KZ, LC, LK, LR, LS, LT, LU, LV, MA, MD, MG, MK, MN, MW, MX, MZ, NO, NZ, OM, PH, PL, PT, RO, RU, SD, SE, SG, SI, SK, SL, TJ, TM, TN, TR, TT, TZ, UA, UG, US, UZ, VN, YU, ZA, ZM, ZW.
- (84) Designated States (regional): ARIPO patent (GH, GM, KE, LS, MW, MZ, SD, SL, SZ, TZ, UG, ZM, ZW), Eurasian patent (AM, AZ, BY, KG, KZ, MD, RU, TJ, TM), European patent (AT, BE, BG, CH, CY, CZ, DE, DK, EE, ES, FI, FR, GB, GR, IE, IT, LU, MC, NL, PT, SE, SK, TR), OAPI patent (BF, BJ, CF, CG, CI, CM, GA, GN, GQ, GW, ML, MR, NE, SN, TD, TG).
- Published:
— with international search report

[Continued on next page]

(54) Title: A MECHANISM AND SYSTEM FOR 3-DIMENTIONAL SCANNING OF AN ULTRASOUND BEAM

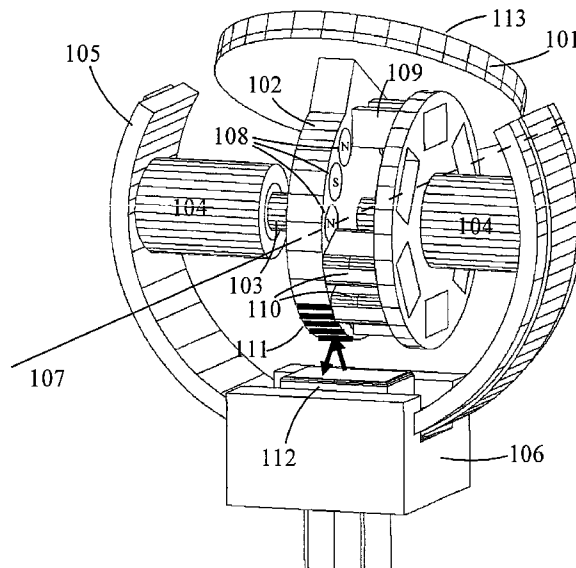

(57) Abstract: An ultrasound probe capable of scanning an ultrasound beam in a region of 3D space, characterized by that an ultrasound transducer array is mounted to a 1st shaft that can rotate in bearings mounted in a fork that can be moved. The fork can be rotated around a 2nd shaft in a bearing, or moved through a sliding system, or a combination of the two. The shaft and the fork are connected to two separate electric motors for electric steering of the array direction within a region of 3D space. Position measurement systems are mounted to the shaft and the fork so that the beam direction can be steered with a feed-back control system.

WO 2004/006773 A1



— *with amended claims*

For two-letter codes and other abbreviations, refer to the "Guidance Notes on Codes and Abbreviations" appearing at the beginning of each regular issue of the PCT Gazette.

A mechanism and system for 3-dimensional scanning of an ultrasound beam.

1. Field of the invention

5

The present invention is directed to technology and methods for scanning an ultrasound beam in a free direction within a region of 3D space. The technology has particular applications within 3D medical ultrasound imaging, but also has applications in other areas of ultrasound imaging or other areas where mechanical movement of an object in 3D space is required.

10

2. Background of the invention

15

Three-dimensional (3D) ultrasound imaging of biological structures can be done by scanning a pulsed ultrasound beam in a 3D manner, and recording the back-scattered ultrasound signal in each beam direction. The principle was described already in the 50'ies, and several instruments have been build that applies the method.

20

25

With 3D imaging, it is important that the ultrasound beam is maximally focused, symmetrically in all directions around the beam axis, as one wants to observe the object from any direction (perspective), and small objects can be interrogated with a variety of beam directions. Such symmetric focusing can be obtained by subdividing the elements of a linear transducer array in the elevation direction, i.e. the direction normal to the two-dimensional (2D) scan plane. The 2D scan plane is often referred to as the azimuth scan plane, while the direction normal to the 2D scan plane is referred to as the elevation direction. Linear arrays with subdivision of the elements in the elevation direction are referred to as 1.5D or 1.75D arrays, depending on whether the elements can be symmetrically or individually steered around the azimuth mid plane. A problem with the subdivision of the elements is that the size of the elements are reduced, increasing the element impedance and hence also noise. The subdivision also gives a large total number of elements, leading to a large number of wires between the array elements and the electronic beam former. This increases cable losses and hence sensitivity of the array.

30

35

40

45

50

Symmetric focusing of the beam can be obtained with much fewer and larger elements with an array of concentric annular elements, the so-called annular array. The larger elements provide lower element impedances and hence less noise and cable losses. Another advantage with the annular array, is that it is covered in a dome, so that the array itself is not pushed against the body or other objects as the linear arrays typically are done. This allows the use of

materials with lower characteristic impedance for mechanical backing support with the annular array compared to the linear arrays, giving less acoustic backing losses and hence better sensitivity with the annular array.

5

Hence the annular array provides better sensitivity for symmetrical focusing of the beam around the beam axis than the linear arrays, due to the large elements and low impedance backing material. The increased sensitivity in turn allows the use of higher ultrasound frequencies and hence better resolution for a given depth, than the linear arrays. The low number of elements also reduces the number of connecting cables and hence gives a lower manufacturing cost of the array.

10

15

A problem with the annular array for 3D beam scanning, is that scanning of the beam direction requires mechanical movement of the array. 3D scanning of the beam with small size of the whole scanning mechanism is then difficult, and the present invention provides a solution to this problem. With a particular embodiment of the invention, the annular array beam can be scanned in a 3D sector with more than 200 deg opening angle in both the elevation and the azimuth directions, with a dimension of the scan-head only slightly larger than the active radiation aperture of the array. The narrow head and wide scanning angle provide a probe that is small and easy to handle, and has special advantages for endoluminal and surgical imaging, where the probe is placed in narrow channels with limited possibilities to direction steer the probe, like for example with transvaginal, transrectal, transesophageal, transgastric, and transintestinal imaging, and imaging from narrow surgical wounds.

20

25

30

3. Summary of the drawings

35

Figure 1 shows particular embodiments according to the invention that provides rotation of a transducer or transducer array around an azimuth axis defined by a 1st shaft that rotates in bearings mounted in a fork that can be moved, where Figure 1a shows sliding of the fork in a sliding system that provides rotation of the array around an elevation axis normal and close to the azimuth axis, Figure 1b shows sliding of the fork in a sliding system that provides rotation of the array around an elevation axis normal to the azimuth axis and at a distance from the azimuth axis, Figure 1c shows rotation of the fork around a 2nd shaft that provides rotation of the array around an elevation axis, and Figure 1d shows combined rotation of fork around a roll axis.

50

Figure 2 shows an example of a control system for driving the rotation of the transducer around the azimuth axis to

follow an azimuth reference signal.

Figure 3 shows a system with flexible bands thread around a pully wheel attached to an electric motor for moving the fork in a sliding system.

4. Detailed description of the invention

A particular embodiment of the invention will be described with reference to the drawings. In **Figure 1a** 101 shows an annular array that is attached to the rotor 102 of an electric motor that is attached to a shaft 103 that is free to move in bearings 104 mounted in a fork 105. Rotating the array around the shaft 103 scans the ultrasound beam in an angular direction referred to as the azimuth direction, within a 2D plane referred to as the azimuth plane. The fork 105 is mounted in a sliding system 106 which allows movement of the shaft. In this particular embodiment, the fork has a circular shape so that sliding of the fork through the sliding system produces a rotation of the shaft 103 around an axis 107, normal to the shaft, which allows angular scanning of the beam in what is referred to as the elevation direction. Moreover, this particular embodiment produces a rotation of the shaft around an axis on the same side of the sliding system as the shaft itself, and the axis 107 goes through the center of the shaft 103. This embodiment allows for a compact size of the mechanism in relation to the size of radiating acoustic surface aperture 113 of the transducer array 101.

Figure 1b shows a modification of the embodiment where the sliding system 120 slides along a fork 121, arranged so that the shaft 103 rotates around an axis 122 on the side of the sliding system opposite to the shaft axis 103. An advantage of this sliding system is that the width of the beam scanning area becomes wider at the probe surface, than for the scanning system in Figure 1a. The scanning system in Figure 1a, however, produces a small outer dimension of the probe.

The rotor 102 of Figure 1a contains a set of permanent magnets distributed around the rotor in a sequence with opposite polarities, where in the drawing 3 magnets 108 are visible. Rotation of the rotor 102 causes the magnets to slide between the poles of a set of electromagnets with iron cores 109 with surrounding coils 110. In Figure 1a, some of the magnets are removed for clarity, the cores 109 are shown without coils for some magnets, while the coils 110 around the cores are shown for other magnets. In Figure 1b an embodiment of an entire electromagnet system 123 is shown. By controlling the current in the coils according to standard methods for those skilled in the art, a torque is

developed on the rotor that causes the transducer array to rotate around the shaft axis 103.

5 For this particular embodiment, an optical reflectance grating 111 in Figure 1a is mounted around the rotor periphery. The grating is illuminated with a light emitting diode contained in the unit 112. The light reflected from the grating is picked up with two light detection diodes in the unit 112 that are offset a distance. By monitoring the
10 signals from the two detector diodes one can both observe the direction of movement of the rotor, and its rotation angle measured in steps of 1/4 of the angle between the reflection stripes of the position grating 111, according to well known principles.

15 The system hence provides both a motor to produce a torque on the shaft 103 and a position system to measure the direction and angular rotation of the transducer array around the shaft axis. The motor and the position
20 measurement system can hence be connected in a feed-back control system for rotation of the transducer array around the shaft 103 under feed-back control. This allows precise direction steering of the array around the shaft axis, for example with an electronic control system as shown in **Figure**
25 **2**.

In this Figure, the azimuth angle of the transducer array is measured in a unit 209, which includes 111 and 112 of Figure 1a, producing a measured azimuth angle signal 202. The
30 measured azimuth angle signal 202 is compared with an azimuth angle reference signal 201 in the unit 210 that produces the angular position error 203 as the difference between the reference and the measured position. The position error signal is fed to a controller unit 204 that
35 provides inputs 205 to the motor drive unit 206 that provides a set of electric drive signals 207 for the motor electromagnetic system 123 of Figure 1b. The control system hence drives the rotor azimuth angle to follow the azimuth angle reference.

40 To scan the beam in the elevation direction in Figure 1a, the fork is moved in the sliding system 106. A system to control such sliding according to the embodiment, is shown in **Figure 3**. Two flexible bands 301 and 302 are attached to
45 the fork 105, so that when one of the bands are pulled, the fork slides in the sliding system 106. This sliding produces a movement of the azimuth rotation axis of the shaft 103, where in this particular embodiment the shaft rotates around an elevation axis 107 normal to the shaft axis. The combined
50 rotation around the azimuth shaft axis 103 and the elevation fork axis 107, produces a 3D sector scanning of the beam in both the azimuth and the elevation directions. In this embodiment, the two flexible bands 301 and 302 are connected

together in a loop around a pulley wheel 303 connected to a rotating electrical motor 304. Angle controlled rotation of the motor 304, for example by a control system similar to that in Figure 2, causes a controlled rotation of the transducer around the elevation axis 107.

5 A third method according the invention of moving the azimuth rotation axis 103 is illustrated in **Figure 1c**, where the fork 105 is connected to a 2nd shaft 125 that can rotate in the bearing system 126 to rotate the array 113 around both
10 the elevation axis 127 and the azimuth axis 103.

A fourth method according the invention of moving the azimuth rotation axis 103 is illustrated in **Figure 1d**, where the fork 105 is mounted in a shaft-bearing system 130 that
15 allows the fork and hence the azimuth axis 103 to rotate around the roll axis 131, normal to the azimuth axis. Combined rotation around the azimuth axis 103 and the roll axis 131 produces a 3D scanning of the beam direction. Rotation around the roll axis 131 can be obtained by an
20 electric motor with direct coupling, coupling through a gear or through a set of pulleys.

C l a i m s

1. An ultrasound transducer probe for scanning the direction and focus of an ultrasound beam in 3D space, characterized by
 - an ultrasound transducer array attached to a 1st shaft that is able to rotate in a bearing mounted in a fork,
 - the fork being moveable so that the 1st shaft is moved, so that the transducer array can be directed freely in any direction within a region of 3D space.
2. An ultrasound transducer probe according to claim 1, where the fork is moved through rotation around a 2nd shaft mounted in a bearing.
3. An ultrasound transducer probe according to claim 2, where the 2nd shaft axis is normal to the 1st shaft axis.
4. An ultrasound transducer probe according to claim 3, where the 2nd shaft axis crosses the 1st shaft axis.
5. An ultrasound transducer probe according to claim 1, where the fork is moved through sliding in a sliding system.
6. An ultrasound transducer probe according to claim 1, where the ultrasound array is an annular array.
7. An ultrasound transducer probe according to claim 1, where
 - a 1st electric motor is coupled to the shaft enabling the shaft attached to the array to rotate in the bearing,
 - and a 2nd electric motor is arranged to move the fork, so that through electric drive signals on the motors, the transducer array can be directed freely in any direction within a region of 3D space.
8. An ultrasound transducer probe according to claim 7, where the stator of the 1st electric motor is mounted to the fork and the rotor of the 1st electric motor is mounted to the shaft, enabling the shaft attached to the array to rotate in the bearing mounted in the fork.
9. An ultrasound transducer probe according to claim 5, where the fork has a circular shape and the sliding system is mounted so relative to the fork that the sliding provides a rotation of the shaft around an axis

normal to the shaft.

10. An ultrasound transducer probe according to claim 5, where the sliding system is mounted so relative to the fork that the sliding provides a lateral displacement of the shaft in the plane of the shaft.
11. An ultrasound transducer probe according to claim 5, where the sliding system is mounted so relative to the fork that the sliding provides a rotation of the shaft around an axis on the shaft side of the sliding system, normal to the shaft.
12. An ultrasound transducer probe according to claim 1, where the fork is attached to at least one flexible band, and the movement of the fork is obtained by pulling the flexible band.
13. An ultrasound transducer probe according to claim 12, where the fork is attached to a flexible band on one side, and a spring system on the other side so that bi-directional movement of the fork is obtained by combined action of the spring system and pulling of the flexible band, where pulling of the flexible band moves the fork in one direction and the spring pulls the fork in the opposite direction when the pull in the flexible band is released.
14. An ultrasound transducer probe according to claim 12, where the fork on each side is attached to separate flexible band, and bi-directional movement of the fork is obtained by selectively pulling one of the bands.
15. An ultrasound transducer probe according to claim 12 to 14, where the pulling of the flexible band(s) is done by an electric motor.
16. An ultrasound transducer probe according to claim 2, where the second shaft-bearing system is mounted to a sliding system that allows movement of position and direction of the second shaft-bearing system, a 3rd electric motor being connected to the sliding system to move the position and direction of the second shaft-bearing system.
17. An ultrasound transducer probe according to claims 7, where the angular position of the 1st shaft and the position of the fork is measured, the position signals being fed to a feed-back controller that provides drive signals for the electric motors, so that the direction of the ultrasound beam can be steered so that the measured position of the shaft and the fork follows close to a reference signal.

AMENDED CLAIMS

[Received by the International Bureau on 13 November 2003 (13.11.2003):
original claims 1-17 replaced by amended claims 1-15 (4 pages)]

1. 1. An ultrasound probe for scanning the direction
5 and focus of an ultrasound beam in 3D space, comprising
- an ultrasound transducer array (101,113) adapted to
emit an ultrasound transmit beam and receive incoming
ultrasound waves through a front face of the transducer
array,
10 - said transducer array being carried by a first shaft
(103) that is able to provide for rotation of the trans-
ducer array in a bearing system (104),
c h a r a c t e r i z e d i n t h a t
- said bearing system is mounted in a fork (105) that is
15 moveable so as to change the angular position of the axis
of said first shaft (103),
- a first electric motor (102,110,123) is arranged behind
the transducer array and has a rotor (102) being
rotationally connected to said transducer array, and a
20 stator (110) connected to said fork (105) to provide for
said rotation of the transducer array around the axis of
said first shaft (103), and
- an angular position sensor element (111) is rotationally
connected to said transducer array (101,113) to indicate
25 the rotation angle of the transducer array and said ultra-
sound beam around said axis,
- so that said ultrasound transmit beam can be directed
freely and controlled in any direction within a region of
3D space to be scanned.

30

2. An ultrasound probe according to claim 1, wherein the
bearing system comprises two bearings (104) being mounted
at mutually opposite locations in the fork (105), and
35 wherein said first motor (102,110), said transducer array
(101,113) and said sensor element (111) are arranged at
said first shaft (103) between the two bearings (104).

3. An ultrasound probe according to claim 1 or 2, where
5 the transducer array is an annular array (101).

4. An ultrasound probe according to claim 1, 2 or 3, where
the fork (105) is moved through rotation around a second
shaft (125) mounted in a bearing (126).
10

5. An ultrasound probe according to claim 1, 2 or 3, where
the fork (105) is moved through sliding in a sliding
system (106).
15

6. An ultrasound probe according to any one of claims 1-5,
where a second electric motor (304) is arranged to move
the fork (105),
so that through electric drive signals on said first and
second motors, the transducer array (101) can be directed
20 freely in any direction within a region of 3D space.

7. An ultrasound probe according to claim 5 or 6, where
the fork has a circular shape and the sliding system (106)
is mounted so relative to the fork that the sliding
25 provides a rotation of said first shaft around an axis on
the same side of the sliding system as said first shaft,
normal to said first shaft.

8. An ultrasound probe according to claim 5 or 6, where
30 the sliding system is mounted so relative to the fork that
the sliding provides a rotation of said 1st shaft around
an axis on the side of the sliding system opposite to said
first shaft, normal to said first shaft.

35

9. An ultrasound probe according to claim 5 or 6, where the sliding system is mounted so relative to the fork that the sliding provides a lateral displacement of said first shaft, possibly in addition to rotation of said first shaft.

10. An ultrasound probe according to claim 1, where the fork (105) is operationally connected to at least one flexible band (301,302), and the movement of the fork is obtained by pulling the flexible band.

11. An ultrasound probe according to claim 10, where the fork is attached to a flexible band on one side, and a spring system on the other side so that bi-directional movement of the fork is obtained by combined action of the spring system and pulling of the flexible band, where pulling of the flexible band moves the fork in one direction and the spring pulls the fork in the opposite direction when the pull in the flexible band is released.

12. An ultrasound probe according to claim 10, where the fork (105) on each side is attached to separate flexible band (301,302), and bi-directional movement of the fork is obtained by selectively pulling one of the bands.

13. An ultrasound probe according to claim 10, 11 or 12 , where the pulling of the flexible band(s) (301,302) is provided for by said second electric motor (304).

14. An ultrasound probe according to any one of claims 4-13, where a second shaft-bearing system (130) is mounted to a sliding system that allows movement of position and direction of the second shaft-bearing system, a third electric motor being connected to the sliding system to move the position and direction of the second shaft-bearing system (130).

15. An ultrasound probe according to any one of claims 6-
14 , where the angular position of the first shaft (103)
and the position of the fork (105) is measured (209), the
position signals being fed to a feed-back controller (204)
5 that provides drive signals (207) for the first and second
electric motors, so that the direction of the ultrasound
beam can be steered so that the measured position of the
shaft and the fork follows close to a reference signal
(201).

10

1/6

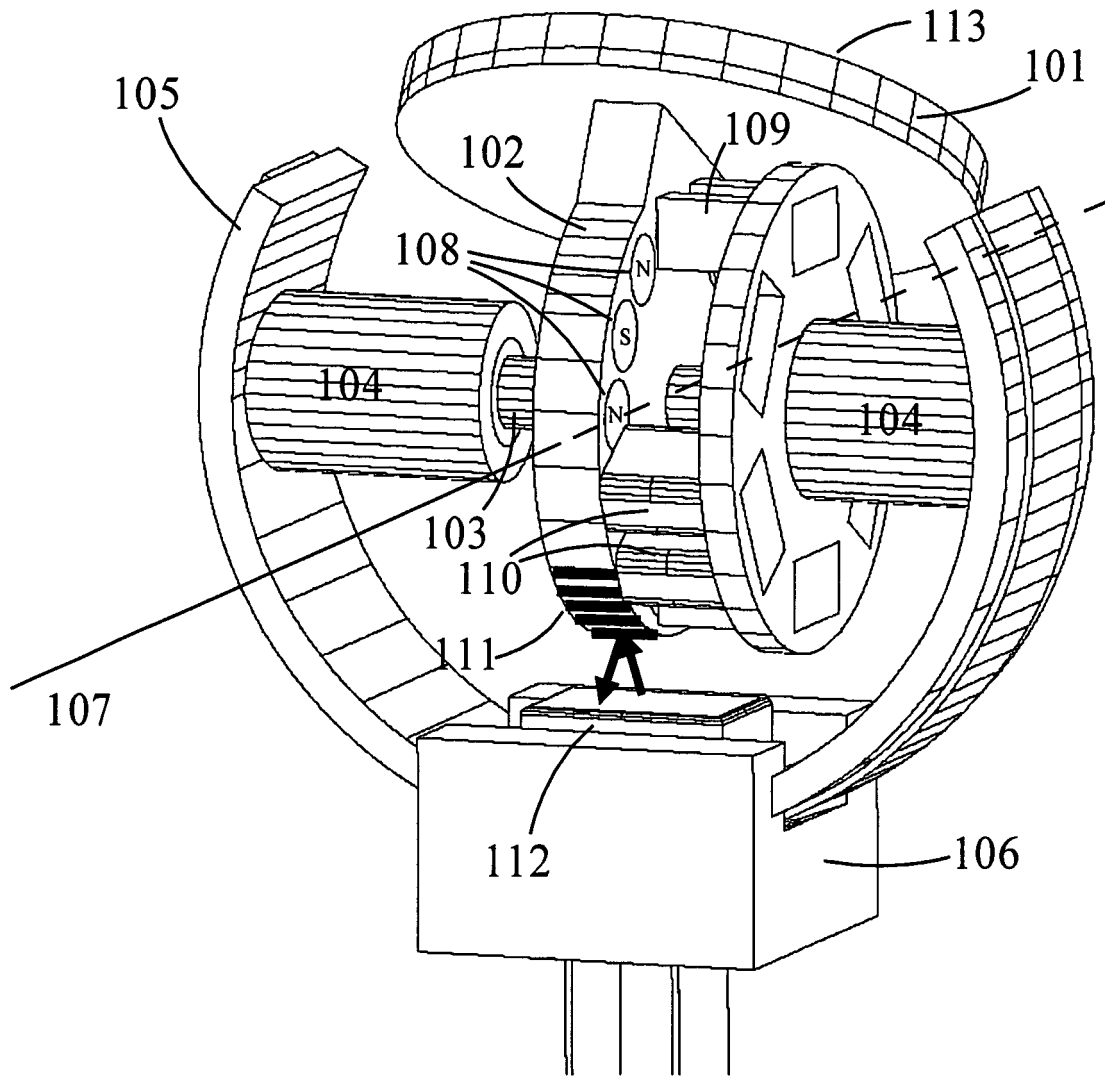

Figure 1a

2/6

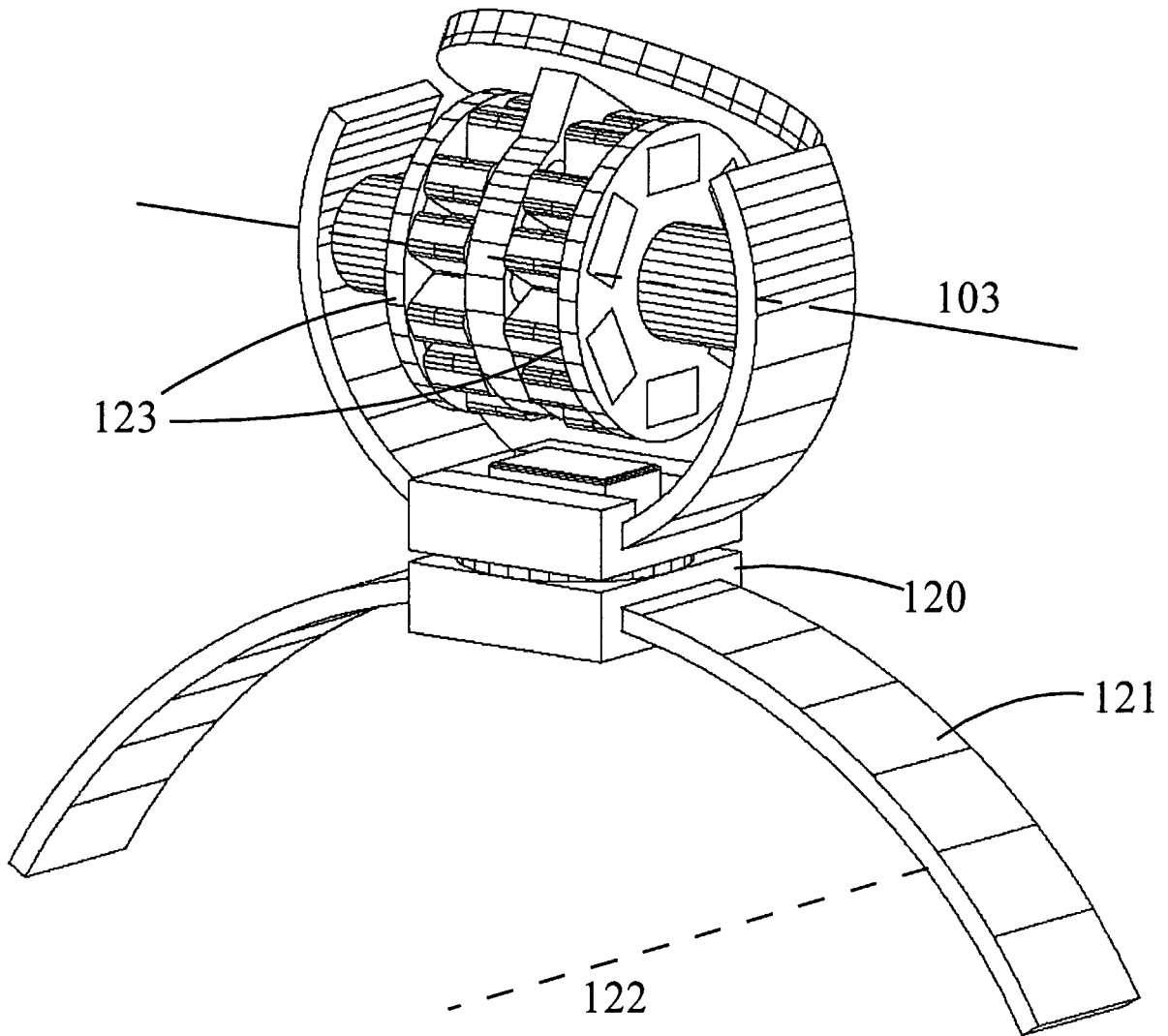

Figure 1b

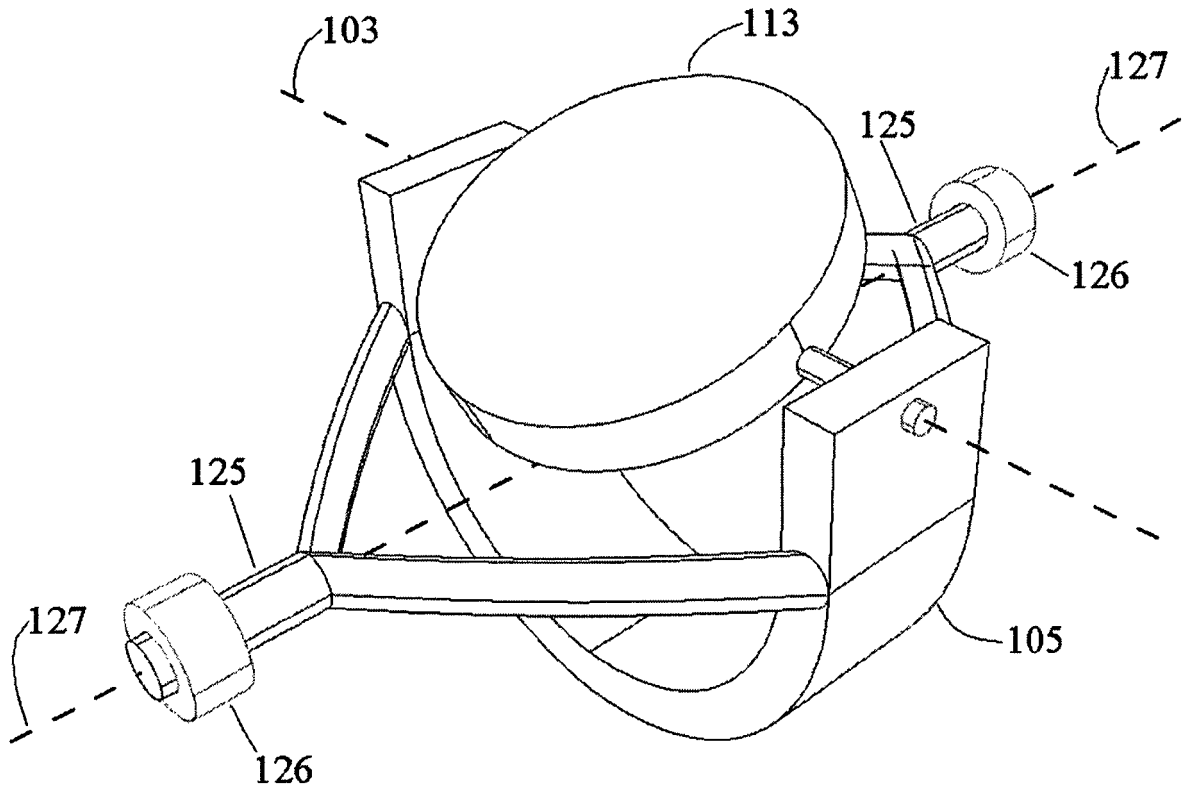

Figure 1C

4/6

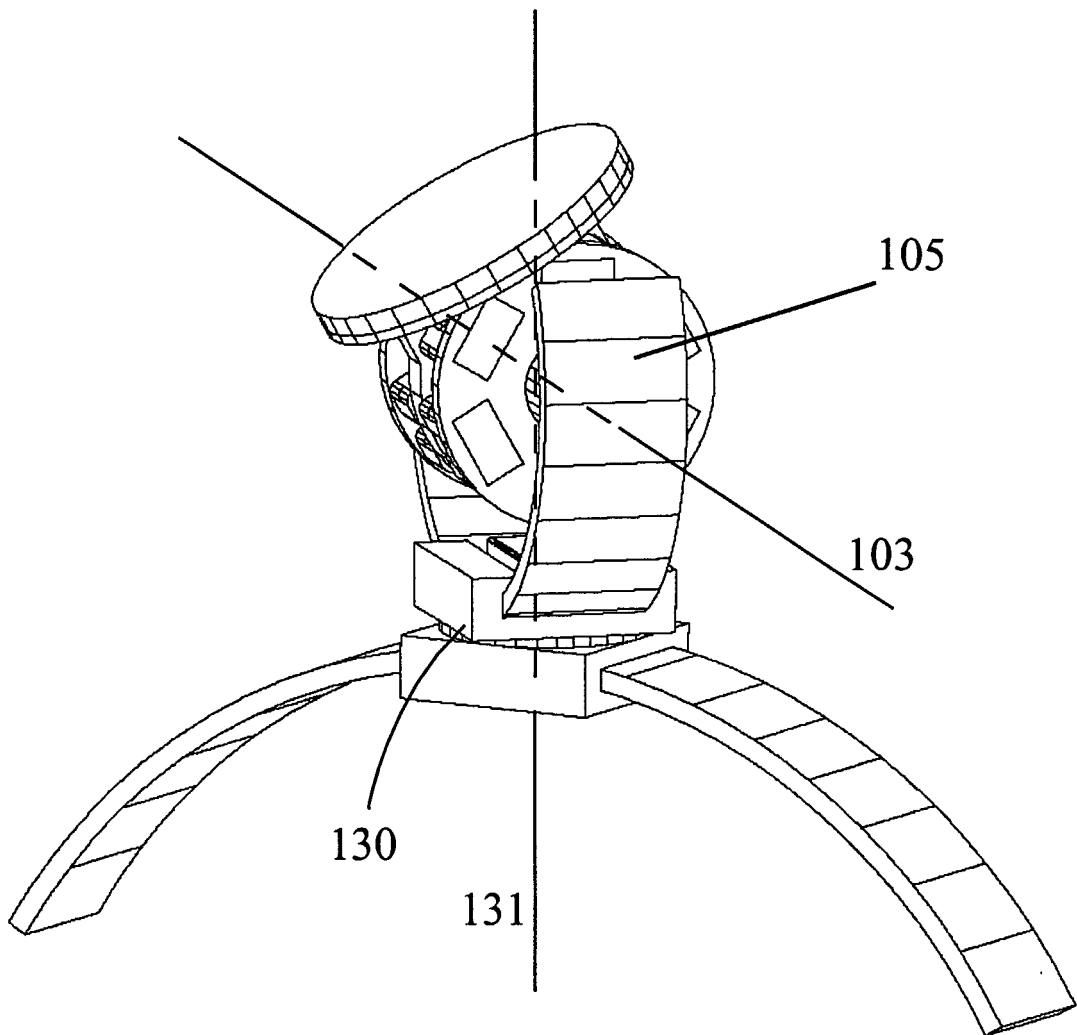

Figure 1d

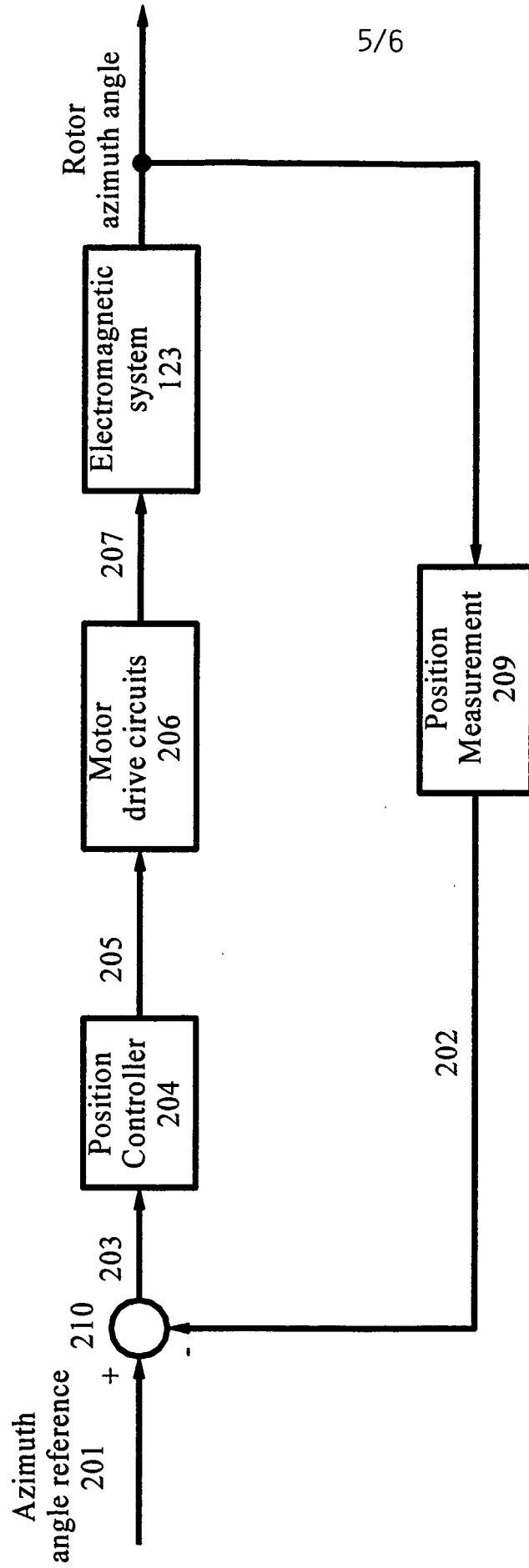

Figure 2

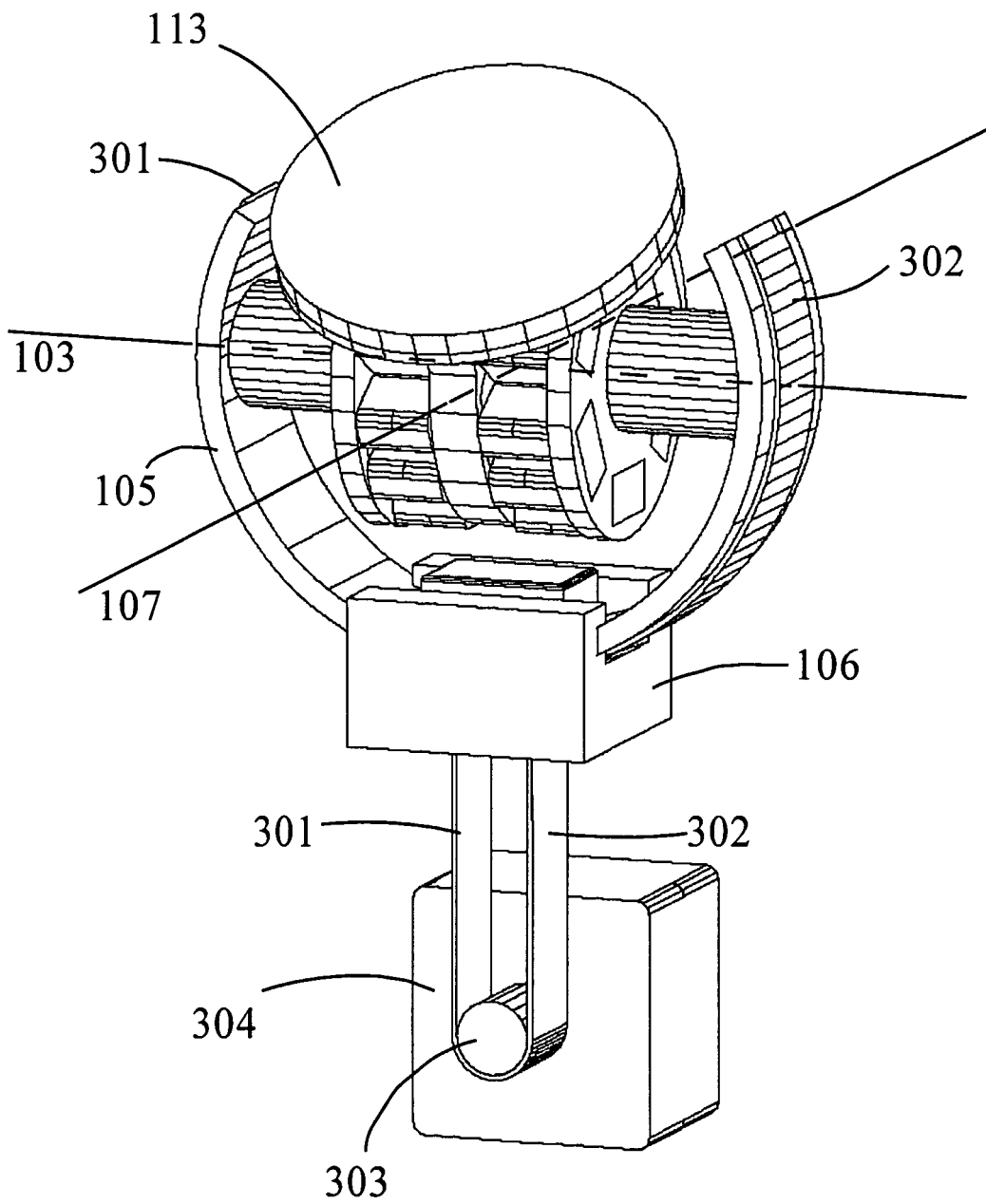

FIGURE 3

INTERNATIONAL SEARCH REPORT

International Application No

PCT/NO 02/00264

A. CLASSIFICATION OF SUBJECT MATTER

IPC 7 A61B8/00 //A61B8/12

According to International Patent Classification (IPC) or to both national classification and IPC

B. FIELDS SEARCHED

Minimum documentation searched (classification system followed by classification symbols)

IPC 7 A61B A61M G01N

Documentation searched other than minimum documentation to the extent that such documents are included in the fields searched

Electronic data base consulted during the international search (name of data base and, where practical, search terms used)

EPO-Internal, WPI Data

C. DOCUMENTS CONSIDERED TO BE RELEVANT

Category °	Citation of document, with indication, where appropriate, of the relevant passages	Relevant to claim No.
X A X A	US 5 094 243 A (DREYER ALAIN ET AL) 10 March 1992 (1992-03-10) See entire document, particularly figures 1-3 --- US 4 841 979 A (DOW JULIAN ET AL) 27 June 1989 (1989-06-27) See entire document, particularly figures 3-7 --- ---	1-9, 12-17 10,11 1-4,6-8, 12-15,17 5,9-11, 16
	-/--	

Further documents are listed in the continuation of box C.

Patent family members are listed in annex.

° Special categories of cited documents :

- "A" document defining the general state of the art which is not considered to be of particular relevance
- "E" earlier document but published on or after the international filing date
- "L" document which may throw doubts on priority claim(s) or which is cited to establish the publication date of another citation or other special reason (as specified)
- "O" document referring to an oral disclosure, use, exhibition or other means
- "P" document published prior to the international filing date but later than the priority date claimed

- "T" later document published after the international filing date or priority date and not in conflict with the application but cited to understand the principle or theory underlying the invention
- "X" document of particular relevance; the claimed invention cannot be considered novel or cannot be considered to involve an inventive step when the document is taken alone
- "Y" document of particular relevance; the claimed invention cannot be considered to involve an inventive step when the document is combined with one or more other such documents, such combination being obvious to a person skilled in the art.
- "&" document member of the same patent family

Date of the actual completion of the international search

7 March 2003

Date of mailing of the international search report

27. 03. 2003

Name and mailing address of the ISA

European Patent Office, P.B. 5818 Patentlaan 2
 NL - 2280 HV Rijswijk
 Tel. (+31-70) 340-2040, Tx. 31 651 epo nl,
 Fax: (+31-70) 340-3016

Authorized officer

PÄR MORITZ/JA A

INTERNATIONAL SEARCH REPORT

International Application No

PCT/NO 02/00264

C.(Continuation) DOCUMENTS CONSIDERED TO BE RELEVANT		
Category °	Citation of document, with indication, where appropriate, of the relevant passages	Relevant to claim No.
X	US 4 579 122 A (SHIMIZU WATARU ET AL) 1 April 1986 (1986-04-01) See entire document, particular figures 3-5 and abstract	1-4,6-8, 12-15,17
A	---	5,9-11, 16
X	US 4 271 706 A (LEDLEY ROBERT S) 9 June 1981 (1981-06-09) column 2, line 20 -column 3, line 44 abstract	1-4,6-8, 12-15,17
A	---	5,9-11, 16
A	US 4 399 703 A (MATZUK TERRANCE) 23 August 1983 (1983-08-23) column 1, line 59 -column 3, line 64 column 10, line 22-60 abstract; figures 1-3,8-13	1-9,17
A	US 4 398 425 A (MATZUK TERRANCE) 16 August 1983 (1983-08-16) abstract; figures 1-6 -----	1-9

INTERNATIONAL SEARCH REPORT

Information on patent family members

International Application No

PCT/NO 02/00264

Patent document cited in search report	Publication date	Patent family member(s)	Publication date
US 5094243	A	10-03-1992	FR 2626773 A1 11-08-1989
			AT 80561 T 15-10-1992
			DE 68902841 D1 22-10-1992
			EP 0327459 A1 09-08-1989

US 4841979	A	27-06-1989	NONE

US 4579122	A	01-04-1986	JP 1729133 C 29-01-1993
			JP 4014016 B 11-03-1992
			JP 60080443 A 08-05-1985

US 4271706	A	09-06-1981	BE 875980 A1 05-11-1979
			CA 1123504 A1 11-05-1982
			DE 2911957 A1 08-11-1979
			DK 180779 A ,B 04-11-1979
			ES 8200555 A1 01-02-1982
			FR 2425081 A1 30-11-1979
			GB 2020428 A ,B 14-11-1979
			IE 48106 B1 03-10-1984
			IT 1113927 B 27-01-1986
			JP 1414685 C 10-12-1987
			JP 54144786 A 12-11-1979
			JP 62021536 B 13-05-1987
			LU 81205 A1 07-11-1979
			MX 146784 A 12-08-1982
NL 7903435 A ,B, 06-11-1979			

US 4399703	A	23-08-1983	BR 8106656 A 24-08-1982
			EP 0051927 A1 19-05-1982
			JP 1612795 C 30-07-1991
			JP 2035938 B 14-08-1990
			JP 57127845 A 09-08-1982

US 4398425	A	16-08-1983	NONE

专利名称(译)	用于超声波束的三维扫描的机构和系统		
公开(公告)号	EP1523273A1	公开(公告)日	2005-04-20
申请号	EP2002770331	申请日	2002-07-15
[标]申请(专利权)人(译)	EAGLE超声		
申请(专利权)人(译)	EAGLE AS超声		
当前申请(专利权)人(译)	TERARECON INC.		
[标]发明人	ANGELSEN BJORN A J JOHANSEN TONNI F KJODE STIG		
发明人	ANGELSEN, BJORN, A., J. JOHANSEN, TONNI, F. KJODE, STIG		
IPC分类号	A61B8/00 A61B8/12		
CPC分类号	A61B8/12 A61B8/4461		
代理机构(译)	HOWE , 史蒂芬		
其他公开文献	EP1523273B1		
外部链接	Espacenet		

摘要(译)

一种能够在3D空间的区域中扫描超声波束的超声波探头，其特征在于，超声波换能器阵列安装到第一轴，所述第一轴可以安装在可移动的叉中的轴承中旋转。叉可以围绕轴承中的第二轴旋转，或通过滑动系统或两者的组合旋转。轴和叉连接到两个单独的电动机，用于在3D空间的区域内对阵列方向进行电动操纵。位置测量系统安装到轴和叉上，使得光束方向可以利用反馈控制系统转向。