



(12) **EUROPEAN PATENT APPLICATION**
 published in accordance with Art. 153(4) EPC

(43) Date of publication:
22.01.2020 Bulletin 2020/04

(51) Int Cl.:
A61B 8/00 (2006.01)

(21) Application number: **18767978.2**

(86) International application number:
PCT/KR2018/002578

(22) Date of filing: **05.03.2018**

(87) International publication number:
WO 2018/169235 (20.09.2018 Gazette 2018/38)

(84) Designated Contracting States:
AL AT BE BG CH CY CZ DE DK EE ES FI FR GB GR HR HU IE IS IT LI LT LU LV MC MK MT NL NO PL PT RO RS SE SI SK SM TR
 Designated Extension States:
BA ME
 Designated Validation States:
KH MA MD TN

(72) Inventors:
 • **KIM, Ji Yeun**
Seoul 05504 (KR)
 • **PARK, Jeong Hyeon**
Seoul 08288 (KR)
 • **SHIN, Seoung Won**
Osan-si
Gyeonggi-do 18109 (KR)
 • **YOO, Seung Schik**
Seoul 06910 (KR)

(30) Priority: **16.03.2017 KR 20170033208**
26.05.2017 KR 20170065629

(74) Representative: **Goddard, Heinz J.**
Boehmert & Boehmert
Anwaltpartnerschaft mbB
Pettenkofferstrasse 22
80336 München (DE)

(71) Applicant: **Neurosona Co., Ltd.**
Songpa-gu
Seoul 05836 (KR)

(54) **MEDICAL HEADGEAR AND TRANSCRANIAL ULTRASOUND TRANSMISSION DEVICE COMPRISING SAME**

(57) Provided are a medical headgear which may be worn on a skull of an object while an ultrasound transducer is supported thereby, and the headgear according to an embodiment of the present disclosure may closely adhere and support an ultrasound transducer to the skull of the object regardless of the size and shape of the skull of the object and a position of the brain to which ultrasound needs to be transmitted. According to the medical headgear as described above, the ultrasound transducer supported on the headgear may be moved to a specific position on the skull, regardless of the position of the brain to which ultrasound needs to be transmitted, and thus, the use convenience of a user may be improved.

FIG. 2

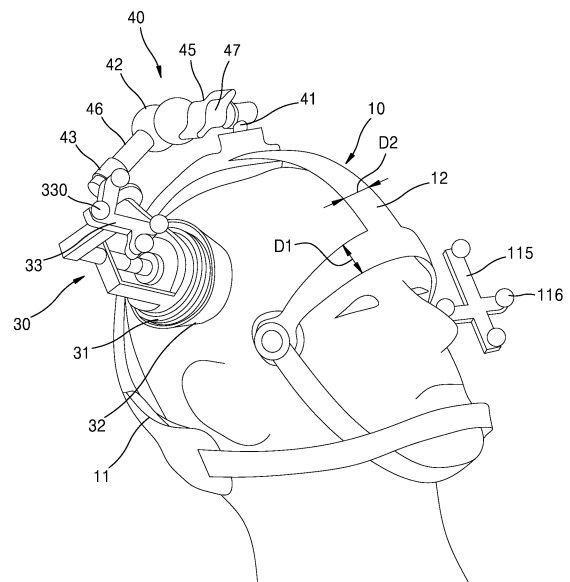

Description

TECHNICAL FIELD

[0001] The present disclosure relates to a medical headgear and a transcranial ultrasound transmission device including the same, and more particularly, to a medical headgear supporting an ultrasound transducer capable of transmitting low intensity ultrasound to transcranial and a transcranial ultrasound transmission device including the same.

BACKGROUND ART

[0002] Brain function is expressed in human cognition and behavior by transmitting signals through a white cortex through activation and deactivation of cell groups distributed in the brain and having specific roles and their biological tissues. To control the brain function, first, there is a method of adjusting a degree to which neurotransmitters are activated in brain cells through drugs. However, it is impossible to control only a desired specific site using a drug. On the other hand, an electrical stimulation using a probe, which is a method of controlling the brain function through an invasive method is possible. In the case of electrical stimulation using such a probe, electrocorticogram or deep brain stimulation (DBS) used in a brain operation makes it possible to transplant or insert the probe into a specific position in the brain and apply the electrical stimulation to temporarily or permanently change the brain function. A similar device is a transcranial magnetic stimulation (TMS) device, which is a technique for controlling the brain function in a noninvasive manner from the outside. This is a method of adjusting the brain function by generating a strong magnetic field outside the skull to induce an induced current in a brain cortex. Such a TMS device has a problem in that a precise control is difficult because not only a non-invasively stimulated area of the brain cortex is too large (2 cm ~ 3 cm or more) but also stimulation is possible only in the skull and a surface of the brain cortex of a depth of 1 cm ~ 2 cm and the magnitude of the magnetic field is drastically reduced in an area located deeper in the brain.

[0003] A device using ultrasound is proposed to solve the above problem. Ultrasound may penetrate the skull upon illumination at a frequency of less than 1 MHz, which is lower than a high frequency used in diagnostic ultrasound devices in a pressure impact waveform and may focus on a deep area of the brain, unlike TMS. Furthermore, it is possible to control a detailed function of a specific brain area because a sphere or an elliptical cone-shaped sphere (a rice grain shape) having a size of 2 mm to 3 mm is affected by ultrasound.

[0004] An ultrasound transducer for generating ultrasound needs to be closely attached to and supported by the skull of a human body so as to transmit ultrasound to transcranial. The skull of the human body may be formed in various sizes and shapes according to race,

age and sex, and an affected part, that is, a position of the brain, to which ultrasound needs to be transmitted, may also vary. Therefore, a user, for example, medical staff, has a problem in constantly adhering and supporting the ultrasound transducer according to the shape and size of the skull and the position of the brain to which ultrasound needs to be transmitted.

DESCRIPTION OF EMBODIMENTS

TECHNICAL PROBLEM

[0005] Provided are a medical headgear capable of being mounted on a skull of an object while supporting an ultrasound transducer, and a transcranial ultrasound transmission device including the same.

[0006] Provided is a medical headgear capable of closely adhering and supporting an ultrasound transducer to a skull of an object regardless of the size and shape of a skull of the object and a position of the brain to which ultrasound needs to be transmitted, and a transcranial ultrasound transmission device including the same.

SOLUTION TO PROBLEM

[0007] According to an aspect of the present disclosure, a medical headgear includes an ultrasound transducer configured to generate a low intensity ultrasound; and a headgear by which the ultrasound transducer is supported, wherein the headgear includes a rear portion case comprising an occipital portion support unit configured to support an occipital and a crown support unit configured to support a crown; and a front portion case connected to the rear portion case to be slidably movable in one direction and comprising two temporal portion support units configured to support both temporal portions.

[0008] The front portion case may include a front portion band extending in one direction and having the two temporal portion support units disposed at both ends, respectively; and a slide band extending in one direction between the crown support unit and the front portion band.

[0009] One end of the slide band may be fixed to the front portion band and another end is slidably supported on an occipital portion case.

[0010] In a first operation mode in which an operation is performed on a frontal lobe, the slide band may slide in a first direction toward the crown support unit, and in a second operation mode in which an operation is performed on a temporal lobe, the slide band may slide so as to be spaced apart from the crown support unit in a second direction opposite to the first direction.

[0011] The medical headgear may further include a slide locking device configured to fix a position of the slide band according to the first and second operation modes.

[0012] The front portion band may be provided with an elastic member deformable along a head circumference

of the object.

[0013] The medical headgear may further include a first marker supported by the occipital portion case and comprising at least one infrared reflector configured to sense a position of the headgear.

[0014] The medical headgear may further include a first lower face support unit extending in one direction and having both ends supported on both ends of the rear portion case respectively to support a lower face of the object.

[0015] The medical headgear may further include a second lower face support unit extending in one direction and having both ends supported on both ends of the front portion band respectively to support a lower face of the object.

[0016] The ultrasound transducer may include an ultrasound generating device configured to generate the low intensity ultrasound and an applicator configured to fix the ultrasound generating device to a scalp of the object.

[0017] The medical headgear may further include a second marker supported by the ultrasound transducer and comprising one or more infrared reflectors configured to sense a focal direction of the ultrasound generating device.

[0018] The medical headgear may further include a connecting device disposed between the headgear and the ultrasound transducer to connect the headgear to the ultrasound transducer.

[0019] The connecting device may include a plurality of link structures.

[0020] The connecting device may include a first connecting bar and a second connecting bar disposed between the headgear and the ultrasound transducer, a first joint configured to connect the headgear to the first connecting bar, a second joint configured to connect the first connecting bar to the second connecting bar, and a third joint configured to connect the second joint to the ultrasound transducer.

[0021] The medical headgear may further include a link restraining device disposed in the second joint to restrain the first joint to the third joint.

[0022] The occipital portion support unit may extend in a circumferential direction of the occipital region, and may further include an occipital portion regulating unit extending or contracting the occipital portion support unit.

[0023] A transcranial ultrasound transmission device according to an embodiment of the present disclosure may include the medical headgear according to an embodiment.

ADVANTAGEOUS EFFECTS OF DISCLOSURE

[0024] According to the medical headgear according to an embodiment of the present disclosure, an ultrasound transducer supported on the headgear may be moved to a specific position of a skull regardless of a position of the brain to which ultrasound needs to be

transmitted, and thus the use convenience of a user may be improved.

[0025] In addition, the medical headgear according to an embodiment of the present disclosure may be supported at three or more places of an object, and thus the positional restraining force between the skull and the headgear may be improved and the supporting force of the ultrasound transducer with respect to the object may be improved.

BRIEF DESCRIPTION OF DRAWINGS

[0026]

FIG. 1A is a block diagram of a transcranial ultrasound transmission device according to an embodiment of the present ultrasound.

FIG. 1B is a perspective view of a transcranial ultrasound transmission device according to an embodiment of the present ultrasound.

FIG. 2 is a perspective view of a medical headgear according to an embodiment of the present disclosure.

FIGS. 3A and 3B are perspective views of a headgear according to an embodiment of the present disclosure.

FIGS. 4A and 4B are a side view and a front view, respectively, of an object wearing a medical headgear for a frontal lobe operation according to an embodiment of the present disclosure.

FIGS. 5A and 5B are a side view and a front view, respectively, of an object wearing a medical headgear for a frontal lobe operation according to an embodiment of the present disclosure.

MODE OF DISCLOSURE

[0027] The principle of the present disclosure is explained and embodiments are disclosed so that the scope of the present disclosure is clarified and one of ordinary skill in the art to which the present disclosure pertains implements the present disclosure. The disclosed embodiments may have various forms.

[0028] Throughout the specification, like reference numerals or characters refer to like elements. In the present specification, all elements of embodiments are not explained, but general matters in the technical field of the present disclosure or redundant matters between embodiments will not be described. Terms 'part' or 'portion' used herein may be implemented using software or hardware, and, according to embodiments, a plurality of 'parts' or 'portions' may be implemented in a single unit or element or a single 'part' or 'portion' may include a plurality of units or elements. The operational principle of the present disclosure and embodiments thereof will now be described more fully with reference to the accompanying drawings.

[0029] In the present specification, an image may in-

clude a medical image obtained by a medical imaging device, such as a computed tomography (CT) device, a magnetic resonance imaging (MRI) device, an ultrasound imaging device, or an X-ray device.

[0030] Throughout the specification, the term 'object' is a thing to be imaged, and may include a human, an animal, or a part of a human or animal. For example, the object may include a part of a body (i.e., an organ), a phantom, or the like.

[0031] The term "ultrasound image" in the entire specification refers to an image of an object that is transmitted to the object and processed based on an ultrasound signal reflected from the object.

[0032] Hereinafter, embodiments will be described in detail with reference to the drawings.

[0033] FIG. 1A is a block diagram of a transcranial ultrasound transmission device according to an embodiment of the present ultrasound. FIG.1B is a perspective view of a transcranial ultrasound transmission device according to an embodiment of the present ultrasound. The transcranial ultrasound transmission device according to an embodiment may include a medical headgear 1, a main body unit 2, a display unit 4, an infrared sensor unit 6, and an input unit 7.

[0034] The transcranial ultrasound transmission device may be implemented not only in cart form but also in portable form. Examples of the portable ultrasound transmission device may include, but are not limited to, a smart phone including the medical headgear 1 and an application, a laptop computer, a PDA, a tablet PC, and the like.

[0035] The medical headgear 1, which is a surgical device capable of transmitting ultrasound to an object while the object is wearing a headgear 10 (see FIG. 2), may include the headgear 10 supported on the head of the object, an ultrasound transducer 30 for transmitting ultrasound to the object, and a position sensing unit M capable of sensing positions of the ultrasound transducer 30 and the headgear 10 by interacting with the infrared sensor unit 6. As an example, the medical headgear 1 may be implemented as a separate type which is connected to the main body unit 2 by wire or wirelessly. Specific details related to the configuration of the medical headgear 1 will be described later in detail with reference to FIGS. 2 to 3.

[0036] The main body unit 2 may control the overall operation of the transcranial ultrasound transmission device and a signal flow between the internal components of the transcranial ultrasound transmission device. The main body unit 2 may include a control unit 21 for processing programs or data, a storage unit 25 for storing programs or data for performing functions of the transcranial ultrasound transmission device, and a communication unit 28 for connecting the control unit 21 to the medical headgear 1.

[0037] As an example, the control unit 21 included in the main body unit 2 may control the overall operation of the transcranial ultrasound transmission device and the

signal flow between the internal components of the transcranial ultrasound transmission device. For example, the control unit 21 may control a transmission unit to form a transmission signal to be applied to each of a plurality of transducers included in the ultrasound transducer 30, taking into consideration positions and focusing points of the plurality of transducers or may control the operation of the transcranial ultrasound transmission device by receiving a control signal from the input unit 7 that will be described later or an external device.

[0038] The storage unit 25 may store various data or programs for driving and controlling the transcranial ultrasound transmission device. As an example, because a program for controlling the medical headgear 1 may be installed in the storage unit 25, the program may include an instruction to perform some or all of operations of the control unit 21. The program may be installed in advance in the storage unit 25 or a user may download a program from a server providing an application and install the program. The server providing the application may include a recording medium storing the program.

[0039] The communication unit 28 that is a communication device for connecting the medical headgear 1 to the main body unit 2 may include one or more components that enable communication between the medical headgear 1 and the main body unit 2. As an example, the communication unit 28 may include at least one of a near distance communication module, a wired communication module, and a wireless communication module. According to an example, the communication unit 28 may receive the control signal and the data and transmit the received control signal to the control unit 21 such that the control unit 21 controls the medical headgear 1 according to the received control signal.

[0040] The display unit 4 may display a generated ultrasound image and various types of information processed by the transcranial ultrasound transmission device. The display unit 4 may include one or a plurality of main display units 141 and a sub-display unit 142 according to an implementation type. One of the main display unit 141 and the sub-display unit 142 may be implemented as a touch screen. The main display unit 141 and the sub-display unit 142 may display the various types of information processed by the transcranial ultrasound transmission device. In addition, the main display unit 141 and the sub-display unit 142 may be implemented as the touch screen and provide a GUI, thereby receiving data for controlling the transcranial ultrasound transmission device from the user. For example, the main display unit 141 may display a control panel for controlling a display of the ultrasound image in a GUI form, and the sub-display unit 142 may display an operation status on an object. The main display unit 141 may receive data for controlling display of an image through the control panel displayed in the GUI form.

[0041] The infrared sensor unit 6 may sense the position of the medical headgear 1 worn by the object and a focus position of ultrasound transmitted by the ultrasound

transducer 30 through infrared transmission and reception with the position sensing unit M disposed on the medical headgear 1. As an example, the position sensing unit M may include a first marker 115 (see FIG. 2) fixed to the headgear 10 and a second marker 33 (see FIG. 2) fixed to the ultrasound transducer 30. The infrared sensor unit 6 according to an embodiment may sense the position of the medical headgear 1, more specifically, a position of the object wearing the medical headgear 1, through an infrared transmission and reception process in relation to the first marker 115 fixed to the headgear 10. The infrared sensor unit 6 may also sense a focus direction and a focus position of the ultrasound in relation to the second marker 33 fixed to the ultrasound transducer 30.

[0042] The input unit 7 may receive an input of the user for controlling the transcranial ultrasound transmission device. For example, an input of the user may include an input for operating a button, a keypad, a mouse, a trackball, a jog switch, a knob, etc., an input for touching a touch pad or a touch screen, a voice input, a motion input, a bio information input (e.g., iris recognition, fingerprint recognition, etc.), and the like, but is not limited thereto.

[0043] FIG. 2 is a perspective view of the medical headgear 1 according to an embodiment of the present disclosure. FIGS. 3A and 3B are perspective views of the medical headgear 1 according to an embodiment of the present disclosure. In the present disclosure, the medical headgear 1 means any of general protective articles to be worn on or supported by the head of an object. The medical headgear 1, according to an embodiment of the present disclosure, which is a support member worn on the head of the object and supported to be fixed to the head of the object, may include the headgear 10 supported by the head of the object, the ultrasound transducer 30, and a connecting device 40 for connecting the headgear 10 to the ultrasound transducer 30 together with the position sensing unit M.

[0044] Referring to FIGS. 2 to 3B, the headgear 10 according to an embodiment may include a rear portion case 11 disposed at a rear portion and supporting the head of the object, a front portion case 12 supported by a temporal portion of the head of the object, a first lower face support unit 13 and a second lower face support unit 14. As an example, the rear portion case 11, which is a support member supported on an occipital and a crown of the head of the object, may include an occipital portion support unit 110, an occipital portion pad 111, a crown support unit 112, and a first marker 115. The occipital portion support unit 110 is a support member capable of tightening or relaxing an occipital side by adjusting a length. At this time, the occipital portion support unit 110 may function as a first support point capable of directly supporting the occipital portion of the object. Further, as an example, the occipital portion support unit 110 may extend in a circumferential direction of the occipital portion of the object and may extend to cover the crown portion of the object. At this time, the occipital portion

support unit 110 may be extended or contracted by an operation of an occipital portion regulating unit 113, thereby tightening or relaxing the occipital side of the object. For example, the occipital portion regulating unit 113 may be provided in adjustable dial form and may be an adjustable member capable of extending or contracting the occipital portion support unit 110 according to a rotational direction of the occipital portion regulating unit 113. As described above, by applying the occipital portion regulating unit 113 to the occipital portion support unit 110, even when a head size of the object, such as a diameter of the head, varies according to race, sex, age, etc., an operator may have the medical headgear 1 worn on the object by a simple operation of the occipital portion regulating unit 113.

[0045] The occipital portion pad 111 is a protecting and buffering member capable of improving the wearing comfort of the object together with the occipital portion regulating unit 113 described above. As an example, the occipital portion pad 111 may be disposed to face the occipital portion support unit 110 and be supported on the occipital portion support unit 110. At this time, the occipital portion pad 111 may be disposed inside the occipital portion support unit 110, that is, between the occipital portion of the object and the occipital portion support unit 110, and thus may be directly supported on the occipital portion of the object.

[0046] The crown support unit 112 is a support member disposed to face the crown of the object and support the crown of the object. As an example, the crown support unit 112 may be fixed to the occipital portion support unit 110 to serve as a second support point for directly supporting the crown of the object. In addition, the crown support unit 112 according to an embodiment may be implemented in pad form to perform a function as a protecting and buffering member to improve the wearing comfort of the object.

[0047] The first marker 115 is a position sensing unit arranged to determine, in real time, a position of the head of the headgear 10, more specifically, the head of the object wearing the headgear 10 when capturing an MRI image or a CT image. As an example, the first marker 115 may be arranged to be supported in the rear portion case 11, more specifically in the occipital portion support unit 110. At this time, the first marker 115 may be attached to the occipital portion support unit 110 in a detachable manner using a magnetic material. In addition, the first marker 115 may include one or more round bar-shaped infrared reflectors 116 that track a position of the occipital portion support unit 110. As an example, the infrared reflectors 116 may be implemented in four and disposed at four ends of a cruciform support unit, respectively.

[0048] As an example, the front portion case 12, which is a support member supported by the temporal portion of the head of the object, may include a front portion band 120, a slide band 121, and temporal portion support units 123. The front portion band 120 is a support member capable of supporting the temporal portion of the object.

As an example, the front portion band 120 may be formed in a band shape extending in one direction, for example, extending from one temporal portion of the head to the other temporal portion in the circumferential direction of the head of the object. At this time, a width D1 of the front portion band 120 may be 1 cm or more and 10 cm or less. Also, at this time, both ends of the front portion band 120 may be disposed to face the temporal portion of the object and function as a third support point and a fourth support point. Also, as an example, the front portion band 120 may be provided in a deformable resilient member such that both ends of the front portion band 120 may be further approximate or spaced within a restoration range. Therefore, even when the head size of the object, for example, the diameter of the head, varies, the front portion band 120 may be respectively supported on both sides of the object.

[0049] The slide band 121 is a slide member capable of moving the front portion band 120 according to an operation position of the object. As an example, the slide band 121 may be provided in a band shape extending in one direction between the crown support unit 112 and the front portion band 120, for example, extending from the crown of the object to the front portion band 120. At this time, a width D2 of the slide band 121 may be 1 cm or more and 10 cm or less, thereby allowing the temporal portion of the object to be opened. Also, at this time, one end of the slide band 121 may be arranged to be fixed to the center of the front portion band 120, and the other end may be supported to be slidable in the front portion case 12, more specifically, the occipital portion support unit 110. As an example, the occipital portion case 12, for example, the occipital portion support unit 110, may be provided with a slide guide on which the slide band 121 may slide. Accordingly, the slide band 121 may be inserted into the occipital portion support unit 110 by sliding in a first direction toward the crown support unit 112 in a first operation mode, for example, when an operation is performed on a frontal lobe, and may be disposed on a front surface of the object by sliding away from the crown support unit 112 in a second direction opposite to the first direction in a second operation mode, for example, when an operation is performed on a temporal lobe. At this time, a slide lock device 114 disposed in the occipital portion support unit 110 may control a slide of the slide band 121 such that a position of the slide band 121 is fixed in each of the first operation mode and the second operation mode. A slide of the front portion case 12 in the first and second operation modes will be described in more detail with reference to FIGS. 4A and 4B.

[0050] The temporal portion support units 123 are support members which may be disposed at both ends of the front portion band 120 and supported by the front portion band 120. As an example, the temporal portion support units 123 may be implemented in the form of a pad, which is a protecting and buffering member for improving the wearing convenience of the object. At this time, the temporal portion support units 123 may be dis-

posed inside the front portion band 120, that is, between the temporal portion of the object and the front portion band 120, and thus may be directly supported on the temporal portion of the object.

[0051] The first lower face support unit 13 is a support member for supporting a lower face of the object, and may have a band shape extending in one direction. As an example, the first lower face support unit 13 may be arranged such that the respective ends of the first lower face support unit 13 are fixed at both ends of the rear portion case 11. For example, when the object wears the headgear 10, the first lower face support unit 13 may be fixed between the mouth and the jaw of the object to support the lower face of the object. Also, a length of the first lower face support unit 13 may be adjusted according to the head size of the object.

[0052] The second lower face support unit 14 is a support member for supporting the lower face of the object, and may have a band shape extending in one direction. As an example, the second lower face support unit 14 may be arranged such that the respective ends of the second lower face support unit 14 are fixed at both ends of the front portion band 120. For example, when the object wears the headgear 10, the second lower face support unit 14 may be fixed between the jaw of the object and the first lower face support unit 13 to support the lower face of the object. Also, a length of the second lower face support unit 14 may also be adjusted according to the head size of the object.

[0053] The ultrasound transducer 30 according to an embodiment of the present disclosure may include an ultrasound generating device 31, an applicator 32 and a second marker 33 for identifying a position of the ultrasound transducer 30. The ultrasound generating device 31 according to an embodiment may generate low intensity ultrasound. The low intensity ultrasound may use intensive ultrasound or non-intensive ultrasound. As an example, when the low intensity ultrasound generated by the ultrasound generating device 31 is projected in a specific area, fine mechanical movement may be caused in the specific area of the brain, and thus, brain function may be adjusted. That is, the low intensity ultrasound may be pulsed, and the resulting mechanical energy may be concentrated and synchronized in the specific area of the brain, resulting in a slight vibration. The mechanical vibration generated by the low intensity ultrasound and a transferring motion thereof may enable a receptor of neuronal cells to regulate ion channels to activate or deactivate the brain function.

[0054] The applicator 32 may be in a cylindrical shape having one side open, and the ultrasound generating device 31 may be provided on an outer periphery of an opening to be fixed to the scalp of the object. At this time, the applicator 32 may include a bag (not shown) in which water from which gas is removed is filled in a vacuum state such that a space is not generated between the ultrasound generating device 31 and the scalp of the object. At this time, the bag (not shown) may include a flex-

ible synthetic resin material, and the bag (not shown) may be disposed such that the applicator 32 closely contacts a curvature of the scalp of the object without a space.

[0055] The second marker 33 is a position sensing unit arranged to determine a position of ultrasound in real time when capturing an MRI image or a CT image. As an example, the second marker 33 may include one or more round bar-shaped infrared reflectors 330 that track a focus direction of the ultrasound generating device 31. As an example, the infrared reflectors 330 may be implemented in four and disposed at four ends of a cruciform support unit, respectively.

[0056] The connecting device 40 according to an embodiment of the present disclosure is a connecting member for connecting the ultrasound transducer 30 to the headgear 10. As an example, the connecting device 40 may include a plurality of link structures. At this time, the connecting device 40 may connect first and second connecting bars 45 and 46 using, for example, first through third joints 41 through 43. As an example, the first joint 41 may be arranged to connect the rear portion case 11 provided on the headgear 10 to the first connecting bar 45, and accordingly, one end of the first connecting bar 45 may be moved without any constraint on a three-dimensional space. Also, the second joint 42 may be arranged to connect the first connecting bar 45 to the second connecting bar 46, and accordingly, one end of the second connecting bar 46 may be moved without any constraint on one plane. Also, the third joint 43 may be arranged to connect the second connecting bar 46 to the ultrasound transducer 30. The ultrasound transducer 30 may be disposed in the entire region of the head of the object having the curvature by connecting the rear portion case 11 to the ultrasound transducer 30, using a plurality of joints, and an operation part may be moved and the operation may progress while being supported by the medical headgear 1 worn by the object, thereby improving the operation convenience of the operator. As an example, a link restraining device 47 may be disposed in the second joint 42 to which the first connecting bar 45 and the second connecting bar 46 are connected. Therefore, when the ultrasound transducer 30 is disposed at an operation position of the head of the object, the operator may restrain the first through third joints 41 through 43 using the link restraining device 47, and accordingly, a relative position of the ultrasound transducer 30 relative to the medical headgear 1 may be fixed.

[0057] FIGS. 4A and 4B are a side view and a front view, respectively, of an object wearing a medical headgear for a frontal lobe operation according to an embodiment of the present disclosure.

[0058] Referring to FIGS. 4A and 4B, according to an embodiment of the present disclosure, the medical headgear 1 may be worn by the object for a first procedure mode, that is, for the frontal lobe operation of the object. As an example, the object may wear the headgear 10. At this time, an occipital and a crown of the object may

be supported by the occipital portion support unit 110 and the crown support unit 112. Also, at this time, by adjusting the length of the occipital portion support unit 110 by using the occipital portion regulating unit 113, the head of the object may be tightened or relaxed, and accordingly, the headgear 10 may be worn on the object having various head sizes. Also, at this time, the first lower face support unit 13 and the second lower face support unit 14 may be supported on the lower face of the operator. Also, at this time, the first marker 115 fixed to the occipital portion support unit 110 may sense a position and an orientation of the head of the object wearing the headgear 10 in real time.

[0059] Also, as an example, in a first operation mode, the slide band 121 provided in the front portion case 12 may be inserted into the occipital portion support unit 110 by sliding in a first direction toward the crown support unit 112. Accordingly, a frontal lobe of the object may be open and the operator may manipulate the connecting device 40 to dispose the ultrasound transducer 30 on the frontal lobe of the object and then closely adhere and support the ultrasound transducer 30 to the frontal lobe of the object. At this time, a pair of temporal portion support units 123 supported by the front portion band 120 may be respectively supported on a temporal portion of the object. Also, at this time, the second marker 33 fixed to the ultrasound generator 31 may track a focal direction of the ultrasound generator 31 using the round bar-shaped infrared reflector 330.

[0060] FIGS. 5A and 5B are a side view and a front view, respectively, of an object wearing a medical headgear for a frontal lobe operation according to an embodiment of the present disclosure. For the convenience of description, descriptions that are substantially the same as those given with reference to FIGS. 4A to 4B are omitted.

[0061] Referring to FIGS. 5A and 5B, according to an embodiment of the present disclosure, the medical headgear 1 may be worn by the object for a second operation mode, that is, for the temporal lobe operation of the object. As an example, the object may wear the headgear 10. At this time, an occipital and a crown of the object may be supported by the occipital portion support unit 110 and the crown support unit 112. Also, as an example, in the second operation mode, the slide band 121 provided in the occipital portion case 12 may slide so as to be spaced apart from the crown support unit 112 in a second direction opposite to a first direction and discharged from the occipital portion support unit 110. Accordingly, a temporal lobe of the object may be open and the operator may manipulate the connecting device 40 to dispose the ultrasound transducer 30 on the temporal lobe of the object and then closely adhere and support the ultrasound transducer 30 to the temporal lobe of the object. At this time, a pair of temporal portion support units 123 supported by the front portion band 120 may be respectively supported on a temporal portion of the object. At this time, a position of the temporal portion of

the object supported by the pair of temporal portion support units 123 may be different from a position of the temporal portion of the object supported by the pair of temporal portion support units 123 shown in FIGS. 4A to 4B. Even when an operation position of the object is different as in the above-described embodiment, the operation may be carried out only by a slide movement of the occipital portion case 12 and a movement of the ultrasound transducer 30, and thus, the use convenience of the operator may be improved.

[0062] It will be understood by those skilled in the art that the foregoing description of the present disclosure is for illustrative purposes only and that those of ordinary skill in the art can readily understand that various changes and modifications may be made without departing from the spirit or essential characteristics of the present disclosure. It is therefore to be understood that the above-described embodiments are illustrative in all aspects and not restrictive. For example, each component described as a single entity may be distributed and implemented, and components described as being distributed may also be implemented in a combined form.

[0063] The scope of the present disclosure is defined by the appended claims rather than the detailed description and all changes or modifications derived from the meaning and scope of the claims and their equivalents are to be construed as being included within the scope of the present disclosure.

Claims

1. A medical headgear comprising:

an ultrasound transducer configured to generate a low intensity ultrasound; and
a headgear by which the ultrasound transducer is supported,
wherein the headgear comprises
a rear portion case comprising an occipital portion support unit configured to support an occipital and a crown support unit configured to support a crown; and
a front portion case connected to the rear portion case to be slidably movable in one direction and comprising two temporal portion support units configured to support both temporal portions.

2. The medical headgear of claim 1, wherein the front portion case comprises
a front portion band extending in one direction and having the two temporal portion support units disposed at both ends, respectively; and
a slide band extending in one direction between the crown support unit and the front portion band.

3. The medical headgear of claim 2, wherein one end of the slide band is fixed to the front portion

band and another end is slidably supported on an occipital portion case.

4. The medical headgear of claim 3, wherein in a first operation mode in which an operation is performed on a frontal lobe, the slide band slides in a first direction toward the crown support unit, and in a second operation mode in which an operation is performed on a temporal lobe, the slide band slides so as to be spaced apart from the crown support unit in a second direction opposite to the first direction.

5. The medical headgear of claim 4, further comprising a slide locking device configured to fix a position of the slide band according to the first and second operation modes.

6. The medical headgear of claim 2, wherein the front portion band is provided with an elastic member deformable along a head circumference of the object.

7. The medical headgear of claim 1, further comprising a first marker supported by the occipital portion case and comprising at least one infrared reflector configured to sense a position of the headgear.

8. The medical headgear of claim 1, further comprising a first lower face support unit extending in one direction and having both ends supported on both ends of the rear portion case respectively to support a lower face of the object.

9. The medical headgear of claim 1, further comprising a second lower face support unit extending in one direction and having both ends supported on both ends of the front portion band respectively to support a lower face of the object.

10. The medical headgear of claim 1, wherein the ultrasound transducer comprises an ultrasound generating device configured to generate the low intensity ultrasound and an applicator configured to fix the ultrasound generating device to a scalp of the object.

11. The medical headgear of claim 10, further comprising a second marker supported by the ultrasound transducer and comprising one or more infrared reflectors configured to sense a focal direction of the ultrasound generating device.

12. The medical headgear of claim 1, further comprising a connecting device disposed between the headgear and the ultrasound transducer to connect the headgear to the ultrasound transducer.

13. The medical headgear of claim 12, wherein the connecting device comprises a plurality of link structures.
14. The medical headgear of claim 13, wherein the connecting device comprises a first connecting bar and a second connecting bar disposed between the headgear and the ultrasound transducer, a first joint configured to connect the headgear to the first connecting bar, a second joint configured to connect the first connecting bar to the second connecting bar, and a third joint configured to connect the second joint to the ultrasound transducer.
15. The medical headgear of claim 14, further comprising a link restraining device disposed in the second joint to restrain the first joint to the third joint.
16. The medical headgear of claim 1, wherein the occipital portion support unit extends in a circumferential direction of the occipital region, and further comprises an occipital portion regulating unit extending or contracting the occipital portion support unit.
17. A transcranial ultrasound transmission device comprising:
the medical headgear of any one of claims 1 to 16.

5

10

15

20

25

30

35

40

45

50

55

FIG. 1A

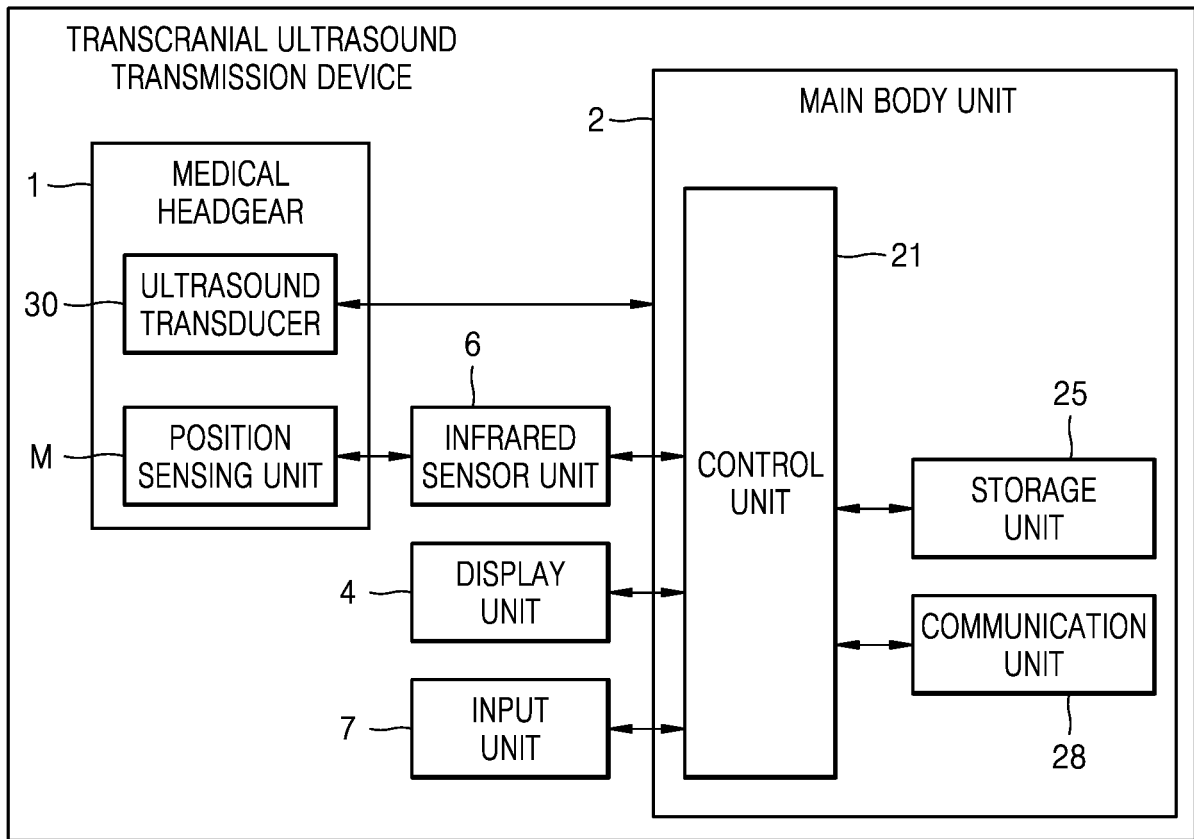

FIG. 1B

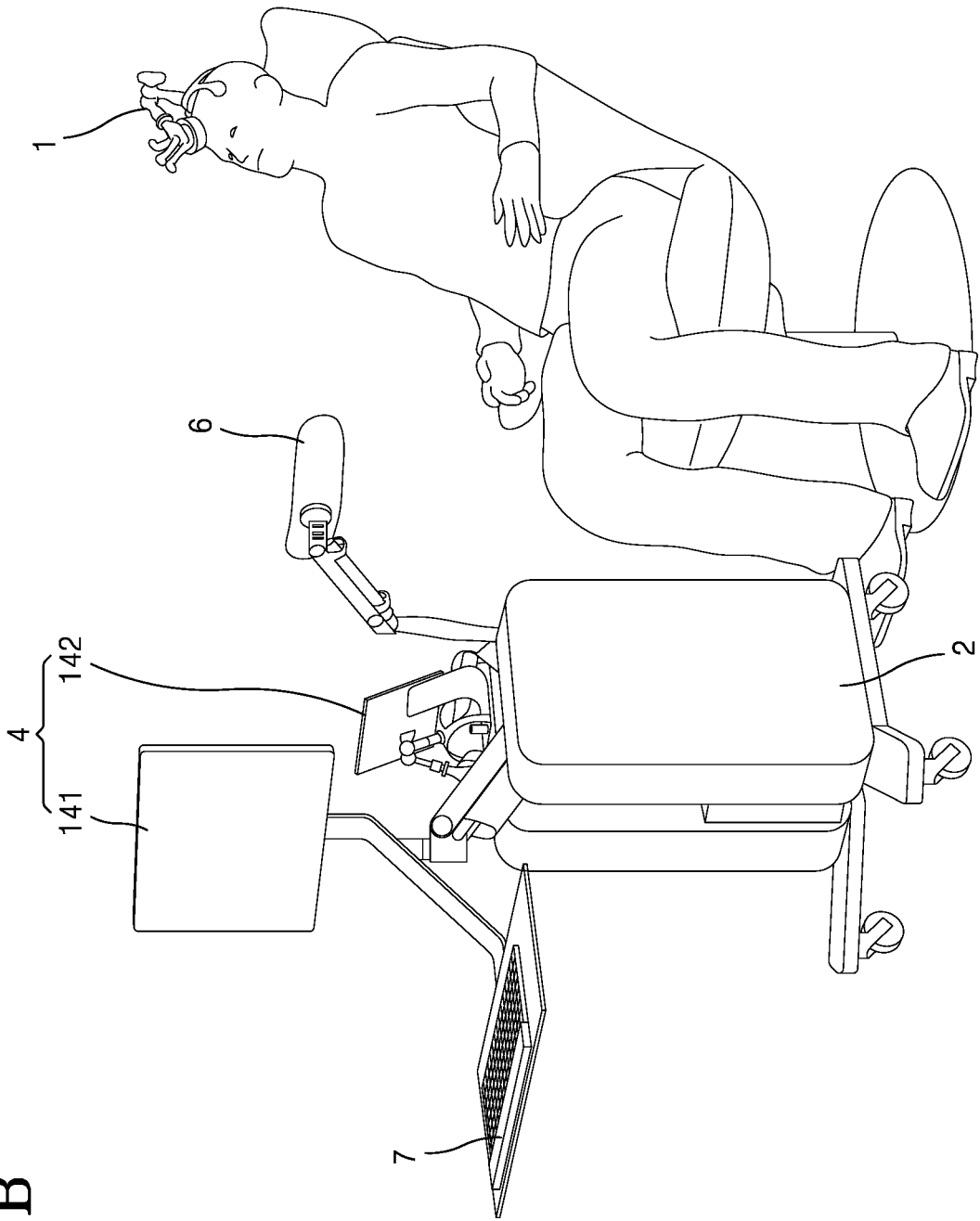

FIG. 2

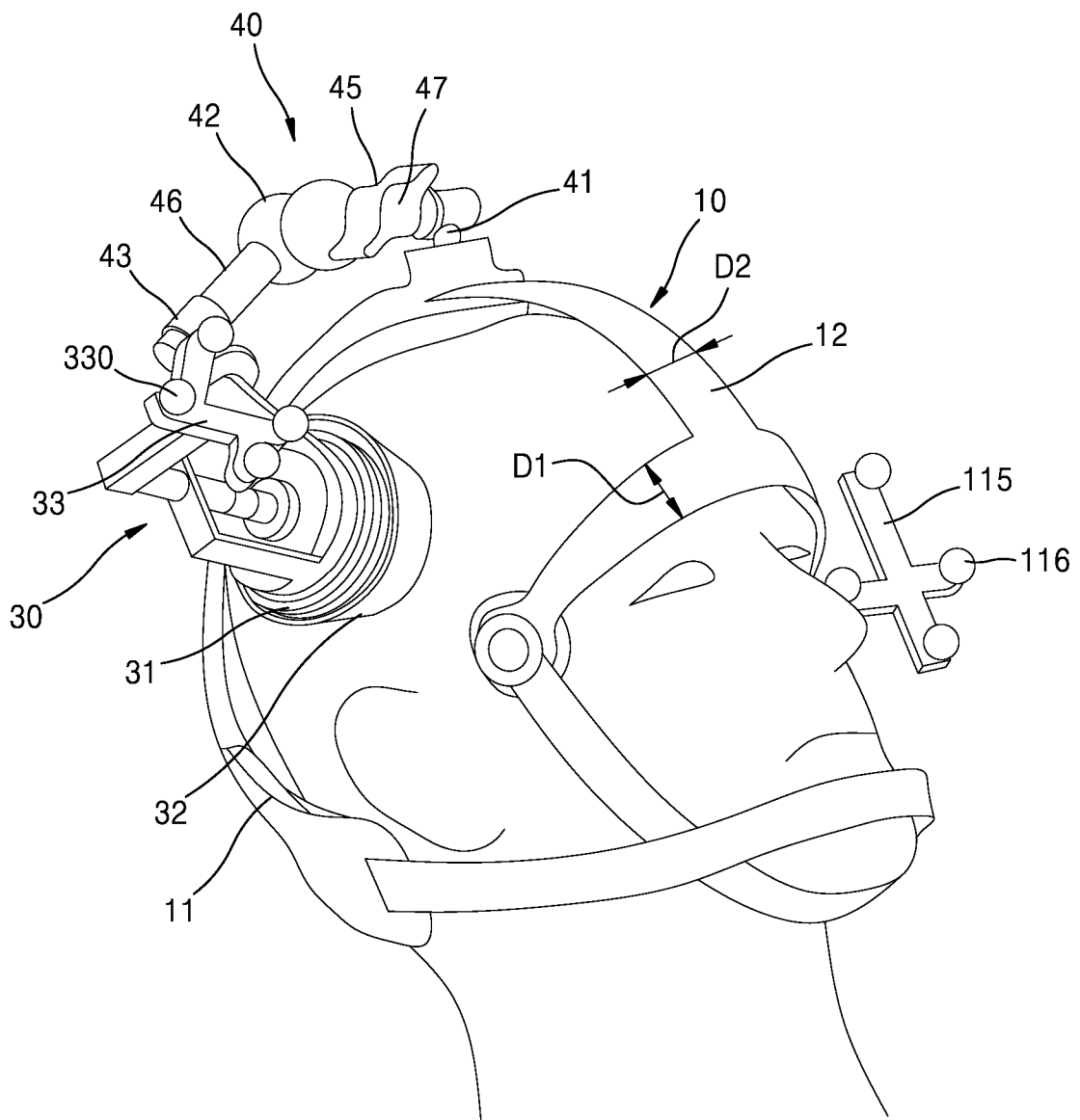

FIG. 3A

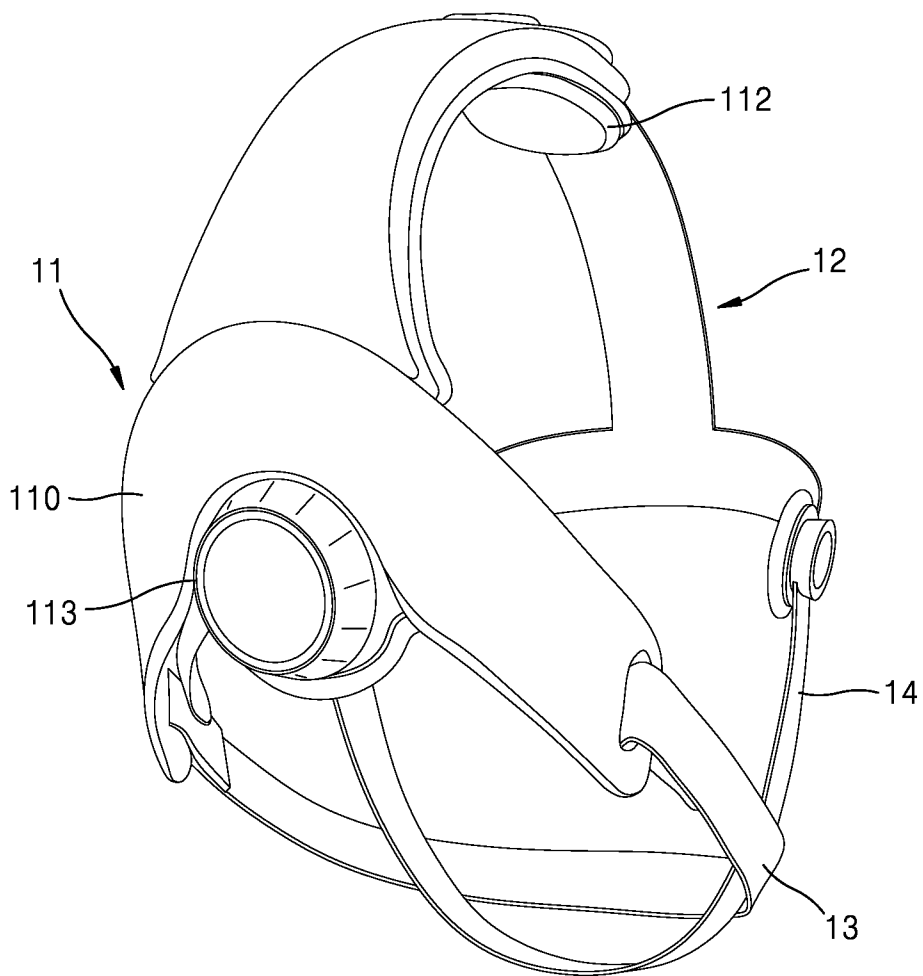

FIG. 3B

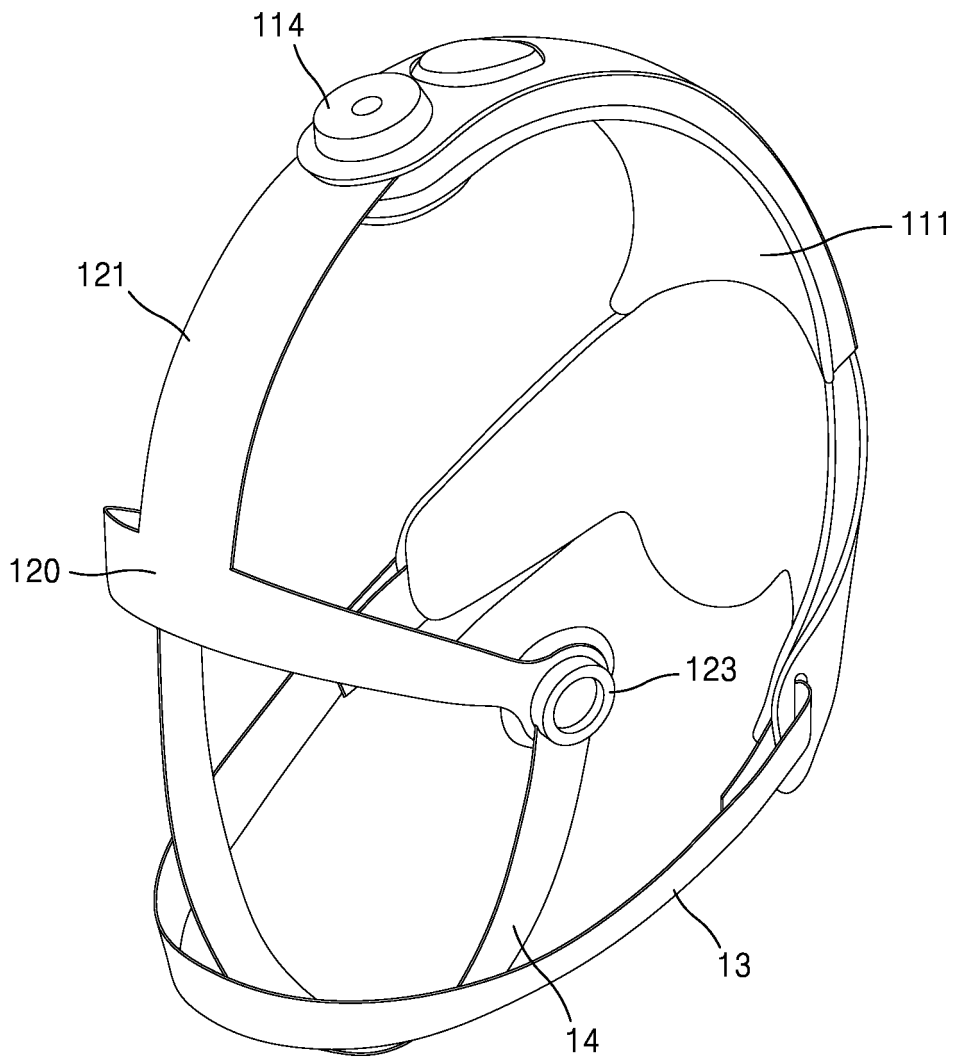

FIG. 4A

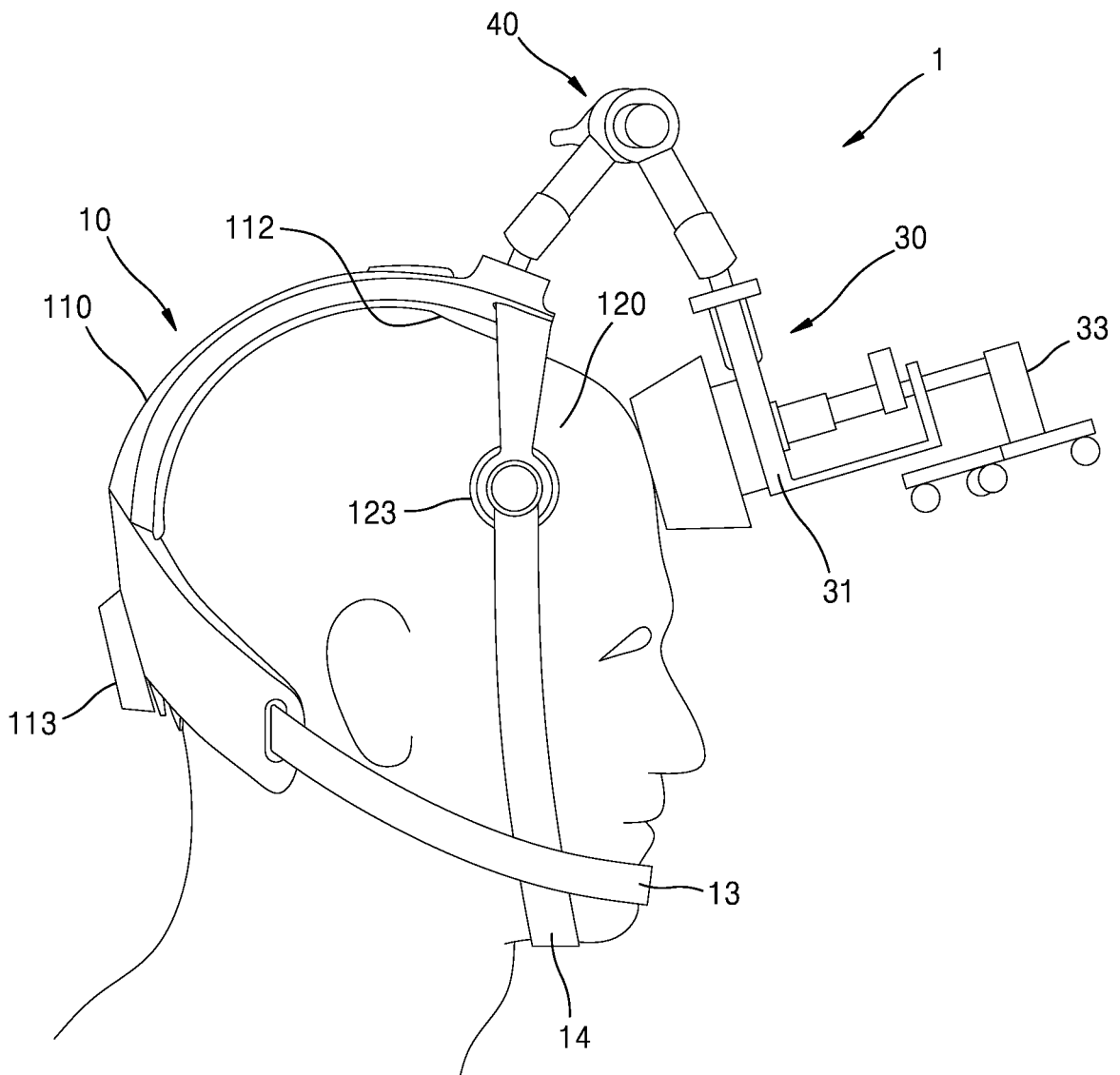

FIG. 4B

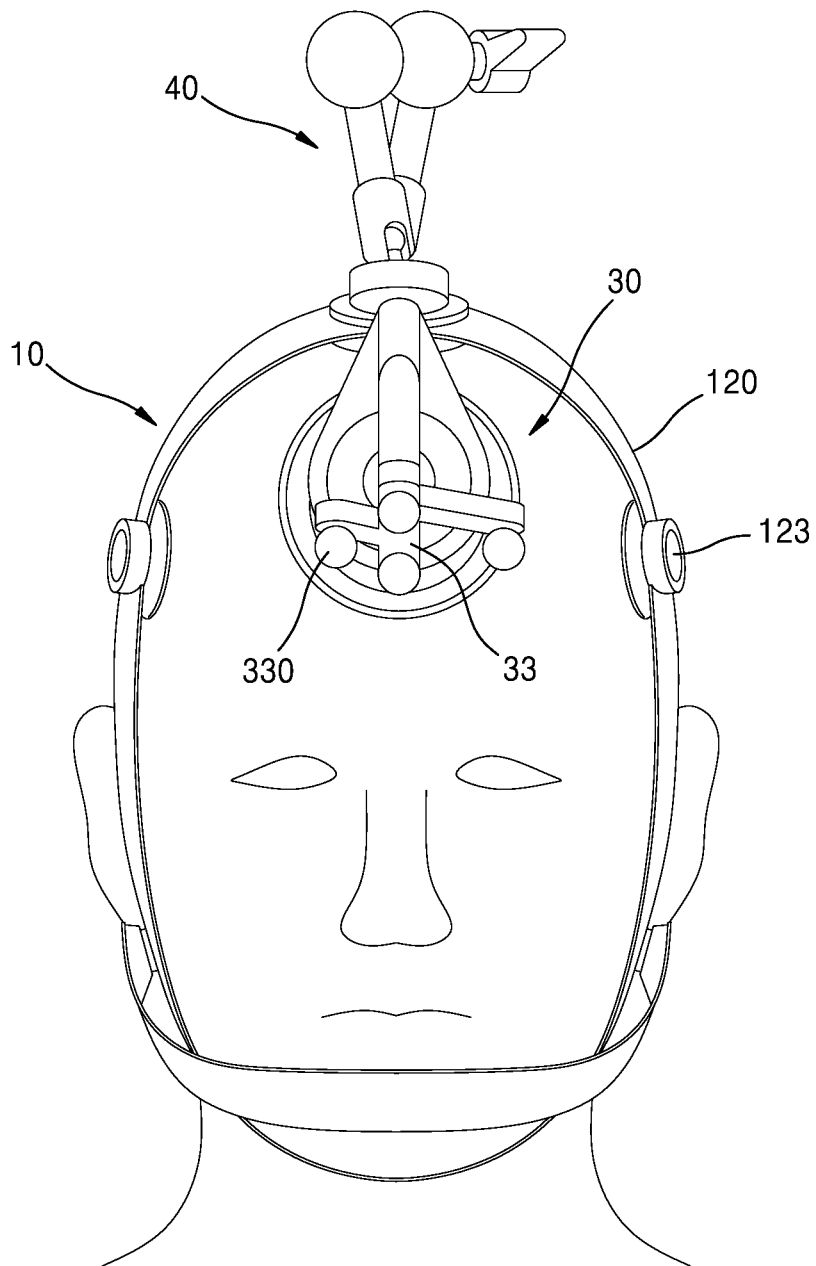

FIG. 5A

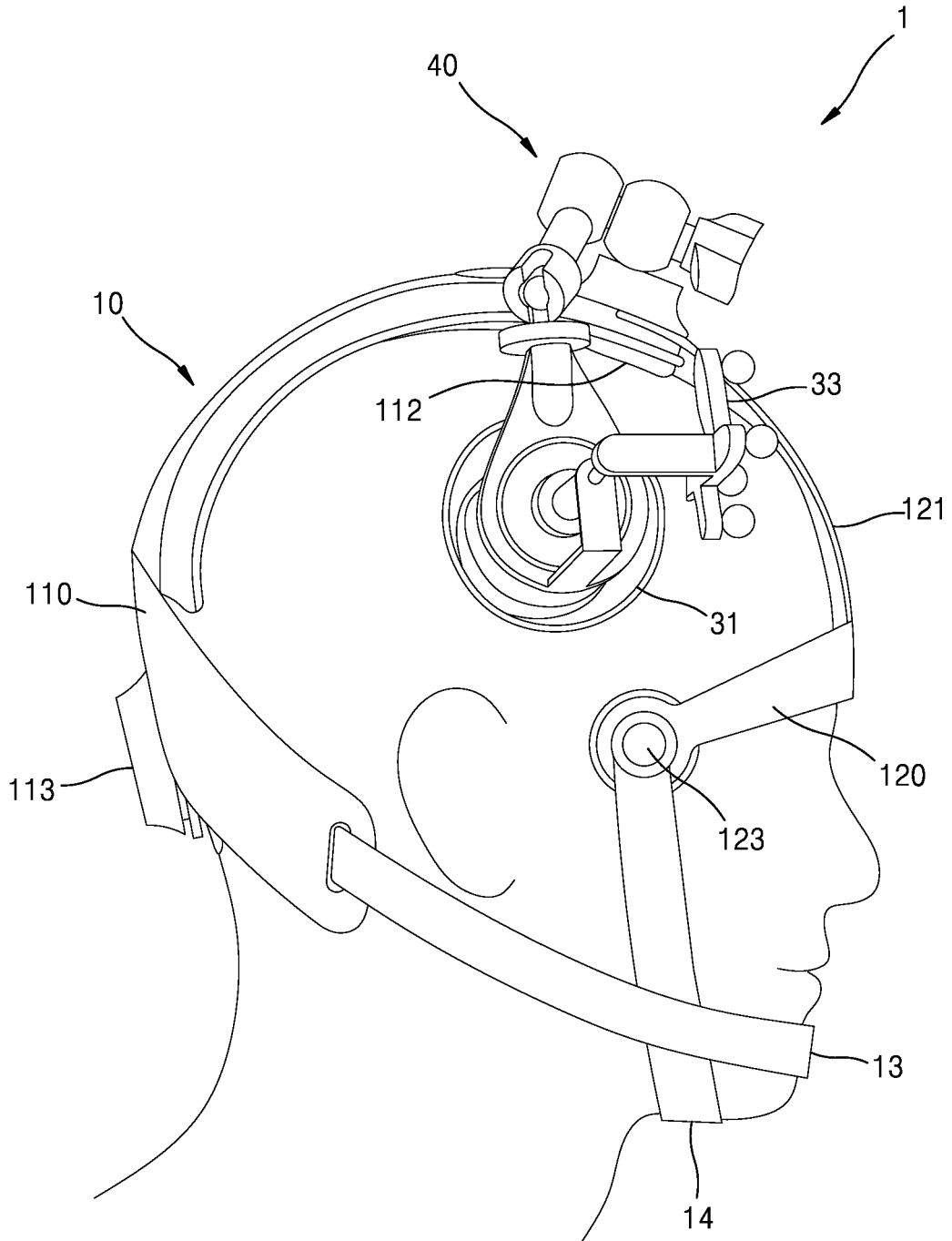
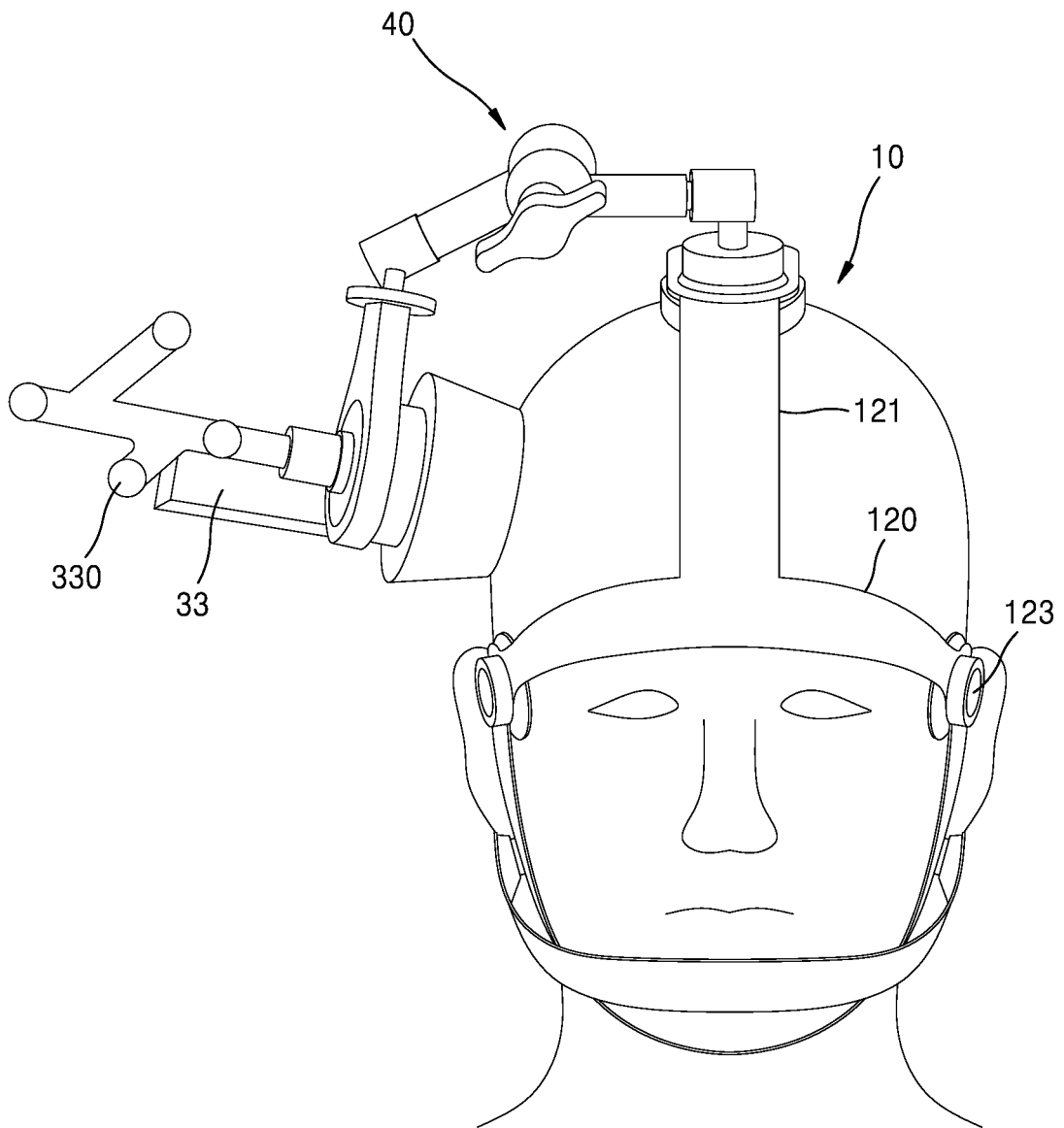

FIG. 5B



INTERNATIONAL SEARCH REPORT

International application No.

PCT/KR2018/002578

5

A. CLASSIFICATION OF SUBJECT MATTER

A61B 8/00(2006.01)ii

According to International Patent Classification (IPC) or to both national classification and IPC

10

B. FIELDS SEARCHED

Minimum documentation searched (classification system followed by classification symbols)

A61B 8/00; A61B 5/0476; A61B 18/00; A61N 7/00; A61B 5/026; A61B 19/00; A61N 7/02; A61B 5/0408

Documentation searched other than minimum documentation to the extent that such documents are included in the fields searched

Korean Utility models and applications for Utility models: IPC as above

Japanese Utility models and applications for Utility models: IPC as above

15

Electronic data base consulted during the international search (name of data base and, where practicable, search terms used)

eKOMPASS (KIPO internal) & Keywords: ultrasonic wave, head gear, support, occipital region, crown of the head, temporal region, case, slide

20

C. DOCUMENTS CONSIDERED TO BE RELEVANT

Category*	Citation of document, with indication, where appropriate, of the relevant passages	Relevant to claim No.
X	JP 2006-305047 A (HITACHI MEDICAL CORP. et al.) 09 November 2006 See paragraphs [0015]-[0019]; claim 5; and figures 2, 4-5.	1-6,17
Y		7-16
Y	KR 10-2015-0055613 A (CHANG GUNG UNIVERSITY et al.) 21 May 2015 See paragraphs [0039], [0056]; and figures 3, 4d.	7,10-11
Y	JP 2016-214608 A (NIPPON KODEN CORP.) 22 December 2016 See paragraph [0033]; and figure 1.	8-9
Y	KR 10-2012-0059232 A (AJOU UNIVERSITY INDUSTRY-ACADEMIC COOPERATION FOUNDATION) 08 June 2012 See paragraphs [0030], [0034]; and figure 2.	12-16
A	KR 10-2015-0102470 A (MSP CO., LTD.) 07 September 2015 See paragraphs [0023]-[0037]; and figures 1-6.	1-17

40

 Further documents are listed in the continuation of Box C.
 See patent family annex.

45

* Special categories of cited documents:	"T" later document published after the international filing date or priority date and not in conflict with the application but cited to understand the principle or theory underlying the invention
"A" document defining the general state of the art which is not considered to be of particular relevance	"X" document of particular relevance; the claimed invention cannot be considered novel or cannot be considered to involve an inventive step when the document is taken alone
"E" earlier application or patent but published on or after the international filing date	"Y" document of particular relevance; the claimed invention cannot be considered to involve an inventive step when the document is combined with one or more other such documents, such combination being obvious to a person skilled in the art
"L" document which may throw doubts on priority claim(s) or which is cited to establish the publication date of another citation or other special reason (as specified)	"&" document member of the same patent family
"O" document referring to an oral disclosure, use, exhibition or other means	
"P" document published prior to the international filing date but later than the priority date claimed	

50

Date of the actual completion of the international search 04 JUNE 2018 (04.06.2018)	Date of mailing of the international search report 04 JUNE 2018 (04.06.2018)
Name and mailing address of the ISA/KR  Korean Intellectual Property Office Government Complex-Daejeon, 189 Seonsa-ro, Daejeon 302-701, Republic of Korea Facsimile No. +82-42-481-8578	Authorized officer Telephone No.

55

Form PCT/ISA/210 (second sheet) (January 2015)

EP 3 597 111 A1

INTERNATIONAL SEARCH REPORT
Information on patent family members

International application No.
PCT/KR2018/002578

5
10
15
20
25
30
35
40
45
50
55

Patent document cited in search report	Publication date	Patent family member	Publication date
JP 2006-305047 A	09/11/2006	NONE	
KR 10-2015-0055613 A	21/05/2015	AU 2013-271506 A1 AU 2013-271506 B2 CA 2876129 A1 CN 103479403 A CN 103479403 B EP 2858619 A1 EP 2858619 A4 IL 236117 A IN 2882KON2014 A JP 2015-521490 A JP 6188036 B2 US 2013-0331685 A1 WO 2013-184993 A1	22/01/2015 09/03/2017 12/12/2013 01/01/2014 22/06/2016 15/04/2015 13/01/2016 29/01/2015 08/05/2015 30/07/2015 30/08/2017 12/12/2013 12/12/2013
JP 2016-214608 A	22/12/2016	CN 107690308 A EP 3297530 A1 WO 2016-185707 A1	13/02/2018 28/03/2018 24/11/2016
KR 10-2012-0059232 A	08/06/2012	KR 10-1204200 B1	26/11/2012
KR 10-2015-0102470 A	07/09/2015	CN 106456995 A KR 10-1532368 B1 KR 10-1572888 B1 KR 10-1674095 B1 KR 10-2015-0102469 A US 2017-0065835 A1 WO 2015-130124 A1	22/02/2017 06/07/2015 30/11/2015 09/11/2016 07/09/2015 09/03/2017 03/09/2015

专利名称(译)	医用头罩及其经颅超声传输装置		
公开(公告)号	EP3597111A1	公开(公告)日	2020-01-22
申请号	EP2018767978	申请日	2018-03-05
[标]发明人	KIM JI YEUN PARK JEONG HYEON SHIN SEOUNG WON YOO SEUNG SCHIK		
发明人	KIM, JI YEUN PARK, JEONG HYEON SHIN, SEOUNG WON YOO, SEUNG SCHIK		
IPC分类号	A61B8/00		
CPC分类号	A61B8/0808 A61B8/4218 A61B8/4245 A61B90/50 A61B2090/374 A61B2090/3762 A61B2090/3954 A61B2090/3966 A61B2090/502 A61B2576/023 A61N2/006 A61N7/00 A61N2007/0026 A61B5/6814 A61B8/4209 A61B8/4281 A61B90/14		
优先权	1020170033208 2017-03-16 KR 1020170065629 2017-05-26 KR		
外部链接	Espacenet		

摘要(译)

提供了一种医疗头带，其可以在被超声换能器支撑时佩戴在对象的头骨上，并且根据本公开的实施例的头饰可以紧密地将超声换能器粘附并支撑到对象的头颅，而与物体头骨的大小和形状以及需要向其发送超声波的大脑位置。根据如上所述的医用头套，支撑在头套上的超声换能器可以移动到颅骨上的特定位置，而与需要向其发送超声的大脑的位置无关，因此，使用方便 用户可能会得到改善。

FIG. 2

