



(12) **EUROPEAN PATENT APPLICATION**
published in accordance with Art. 153(4) EPC

(43) Date of publication:
17.07.2013 Bulletin 2013/29

(51) Int Cl.:
A61B 8/00 (2006.01)

(21) Application number: **11823328.7**

(86) International application number:
PCT/JP2011/065944

(22) Date of filing: **13.07.2011**

(87) International publication number:
WO 2012/032849 (15.03.2012 Gazette 2012/11)

(84) Designated Contracting States:
AL AT BE BG CH CY CZ DE DK EE ES FI FR GB GR HR HU IE IS IT LI LT LU LV MC MK MT NL NO PL PT RO RS SE SI SK SM TR

(72) Inventor: **SATOH, Yoshiaki**
Ashigara-kami-gun
Kanagawa 258-8538 (JP)

(30) Priority: **06.09.2010 JP 2010198566**

(74) Representative: **Klunker . Schmitt-Nilson . Hirsch**
Patentanwälte
Destouchesstrasse 68
80796 München (DE)

(71) Applicant: **FUJIFILM Corporation**
Tokyo 106-0031 (JP)

(54) **ULTRASOUND DIAGNOSTIC DEVICE**

(57) Provided is an ultrasound diagnostic apparatus permitting interchange of transducer arrays to select one having an appropriate frequency band for an intended diagnosis purpose, while achieving reduction in dimensions and improvement in ease of operation. An ultrasound probe 1 includes a middle unit 4 connected to a back unit 2 by wireless communication, and a front unit 3 detachably connected to the middle unit 4 through a

connector 5. The front unit 3 incorporates a transducer array 6 having a specific frequency band, a preamplifier 8 having a frequency band corresponding to the frequency band of the transducer array 6, and a transmission driver 9 that outputs a drive voltage corresponding to the drive voltage for the transducer array 6. The front unit 3, the middle unit 4 and the back unit 2 respectively have dedicated CPUs 10, 15 and 20 for controlling the components in the respective units.

FIG. 1

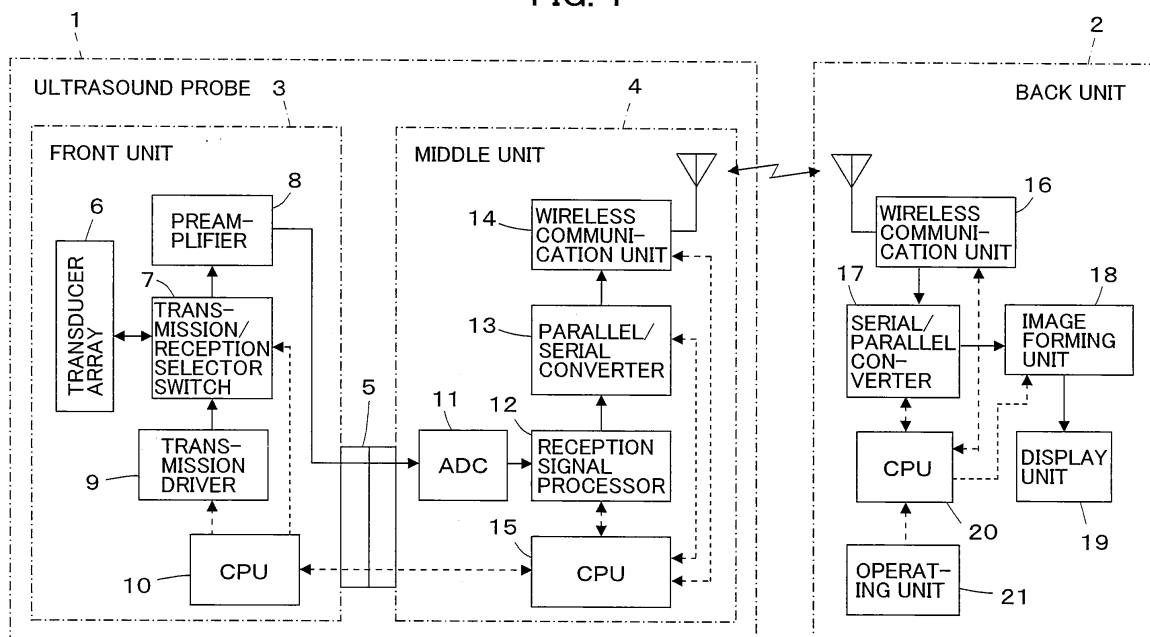

Description

TECHNICAL FIELD

[0001] The present invention relates to an ultrasound diagnostic apparatus and particularly to an ultrasound diagnostic apparatus permitting interchange of transducer arrays of an ultrasound probe.

BACKGROUND ART

[0002] Conventionally, ultrasound diagnostic apparatus using ultrasound images are employed in medicine. In general, this type of ultrasound diagnostic apparatus comprises an ultrasound probe having a built-in transducer array and an apparatus body connected to the ultrasound probe. The ultrasound probe transmits an ultrasonic wave toward a subject, receives an ultrasonic echo from the subject, and the apparatus body electrically processes reception signals to generate an ultrasound image.

[0003] In recent years, there have been developed portable ultrasound diagnostic apparatus that can be transported and placed near a bed or brought to a site where emergency medical care is needed. There have also been conceived ultrasound diagnostic apparatus having a configuration whereby the ultrasound probe and the apparatus body are connected to each other by wireless communication to improve operability. Such ultrasound diagnostic apparatus are required to be available in reduced dimensions for convenience.

[0004] Ultrasound diagnostic apparatus are used to diagnose subjects for various diagnosis purposes depending on which an appropriate frequency band may often vary. Thus, one may consider using an ultrasound probe selected according to the diagnosis purpose from a plurality of ultrasound probes having different frequency bands kept ready for use and connecting the selected probe to the apparatus body. However, because the ultrasound probes are generally expensive, keeping a plurality of ultrasound probes available for use increases the costs. Thus, there is a demand for a transducer array that is detachably provided in the ultrasound probe so that a transducer array having a suitable frequency band for the diagnosis purpose may be selected and used.

[0005] For example, Patent Literature 1 describes an ultrasound diagnostic system wherein an ultrasound probe is comprised of a transducer head containing a transducer array and a beamforming module for processing the signals from the transducer head for beamforming, and wherein the transducer head is detachably mounted to the beamforming module.

Patent Literature 2 describes an ultrasound diagnostic apparatus wherein an ultrasound probe is comprised of a transducer array and a housing for holding the transducer array, and wherein the transducer array is detachably mounted to the housing.

CITATION LIST

PATENT LITERATURE

5 **[0006]**

PATENT LITERATURE 1: JP 2003-190159 A

PATENT LITERATURE 2: JP 2009-60992 A

10

SUMMARY OF INVENTION

TECHNICAL PROBLEMS

15 **[0007]** In the ultrasound probe of the apparatus described in Patent Literature 1, because the transducer head containing the transducer array is detachable from the beamforming module, a transducer array having an appropriate frequency band according to the diagnosis purpose can be used. However, such configuration has a problem in which the beamforming module is required to have therein mounted a broadband preamplifier with a bandwidth of, for example, about 2 to 20 MHz in order to enable operation with a plurality of transducer arrays having different frequency bands, and a pulser capable of a high drive voltage for a transducer array having a maximum drive voltage among the plurality of transducer arrays, resulting in increased dimensions of the apparatus.

20 Likewise, although the ultrasound probe of the apparatus described in Patent Literature 2 permits use of a transducer array having an appropriate frequency band according to the diagnosis purpose, the housing is required to have mounted therein a broadband amplifier and a high drive-voltage pulser, resulting in increased dimensions of the apparatus.

25 **[0008]** The present invention has been made to solve the above problems in the art and has an object of providing an ultrasound diagnostic apparatus permitting interchange of transducer arrays to select one having a suitable frequency band for an intended diagnosis purpose, while achieving reduction in dimensions and improvement of operability.

45 SOLUTION TO PROBLEMS

[0009] The ultrasound diagnostic apparatus according to the present invention is an ultrasound diagnostic apparatus in which an ultrasound probe and a back unit are connected to each other by wireless communication, an ultrasonic beam being transmitted from a transducer array of the ultrasound probe to a subject, the back unit generating an ultrasound image based on reception signals outputted from the transducer array of the ultrasound probe having received an ultrasonic echo from the subject, wherein the ultrasound probe includes a middle unit connected to the back unit by wireless communication and a front unit detachably connected to the middle unit

and including the transducer array, and wherein the front unit has a transmission driver that supplies a drive signal to the transducer array and causes the transducer array to transmit an ultrasonic beam and a preamplifier that amplifies reception signals outputted from the transducer array.

[0010] Preferably, the front unit and the middle unit comprise dedicated CPUs and are detachably connected to each other through a connector that includes a reception signal line for transmitting reception signals amplified by the preamplifier of the front unit and a communication line for transmitting signals between both CPUs.

The front unit may comprise a multiplexer connected to the transducer array.

The transducer array may be so configured as to comprise a transmission transducer array dedicated to transmission and a reception transducer array dedicated to reception. Alternatively, the transducer array may be so configured as to comprise a dual-purpose transducer array for transmission and reception and a harmonic transducer array for harmonic component reception.

[0011] Preferably, the middle unit comprises an A/D converter converting reception signals amplified by the preamplifier of the front unit into a digital signal, a reception signal processor frequency-modulating the digital signal obtained through conversion by the A/D converter to a baseband frequency, and a parallel/serial converter serializing the signal that is frequency-modulated by the reception signal processor.

The middle unit may have at least one of an operating unit performing input operation into the ultrasound diagnostic apparatus and a display unit displaying information.

ADVANTAGEOUS EFFECTS OF INVENTION

[0012] According to the present invention, the ultrasound probe comprises the middle unit connected to the back unit by wireless communication and the front unit detachably connected to the middle unit, and the front unit includes the transducer array, the transmission driver, and the preamplifier, so that selection of the front unit enables selection of a transducer array having an appropriate frequency band for an intended diagnosis, while interchange of transmission drivers and preamplifiers is also made possible, thus achieving reduction in dimensions and improvement in operability.

BRIEF DESCRIPTION OF DRAWINGS

[0013]

FIG. 1 is a block diagram illustrating a configuration of an ultrasound diagnostic apparatus according to Embodiment 1 of the invention.

FIG. 2 is a flow chart illustrating the operation of Embodiment 1.

FIG. 3 is a flow chart illustrating an examination mode

in Embodiment 1.

FIG. 4 is a block diagram illustrating a configuration of a front unit used in Embodiment 2.

FIG. 5 is a block diagram illustrating a configuration of a front unit used in Embodiment 3.

FIG. 6 is a block diagram illustrating a configuration of a front unit used in a variation of Embodiment 3.

FIG. 7 is a block diagram illustrating a configuration of a front unit used in Embodiment 4.

FIG. 8 is a block diagram illustrating a configuration of a front unit used in a variation of Embodiment 4.

FIG. 9 is a block diagram illustrating a configuration of a middle unit used in Embodiment 5.

15 DESCRIPTION OF EMBODIMENTS

[0014] Embodiments of the present invention will be described below based on the attached drawings.

20 Embodiment 1

[0015] FIG. 1 illustrates a configuration of an ultrasound diagnostic apparatus according to Embodiment 1 of the invention. The ultrasound diagnostic apparatus comprises an ultrasound probe 1 and a back unit 2 that is connected to the ultrasound probe 1 via wireless communication.

[0016] The ultrasound probe 1 comprises a front unit 3 and a middle unit 4. The front unit 3 is detachably connected via a connector 5 to the middle unit 4.

The front unit 3 comprises a one-dimensional or two-dimensional transducer array 6 including a plurality of ultrasound transducers. A preamplifier 8 and a transmission driver 9 are connected in parallel to the transducer array 6 via a transmission/reception selector switch 7. A CPU (central processing unit) 10 is connected to the transmission driver 9.

[0017] The middle unit 4 comprises an A/D converter (analog-digital converter circuit) 11 that is connected to the preamplifier 8 of the front unit 3 via the connector 5. A reception signal processor 12 is connected to the A/D converter 11, and a wireless communication unit 14 is connected to the reception signal processor 12 via a parallel/serial converter 13. A CPU 15 is connected to the reception signal processor 12 and the parallel/serial converter 13, and the CPU 15 is connected to the CPU 10 of the front unit 3 via the connector 5.

[0018] The transducers of the transducer array 6 each transmit ultrasonic waves according to drive signals supplied from the transmission driver 9 and receive ultrasonic echoes from a subject to output reception signals. Each of the transducers is constituted, for example, by a vibrator including a piezoelectric body made of a piezoelectric ceramic typified by PZT (lead zirconate titanate) or a polymeric piezoelectric element typified by PVDF (polyvinylidene fluoride) and electrodes provided on both ends of the piezoelectric body.

When the electrodes of the vibrators are supplied with a

pulsed voltage or a continuous-wave voltage, the piezoelectric bodies expand and contract to cause the vibrators to produce pulsed or continuous ultrasonic waves. The ultrasonic waves are combined to form an ultrasonic beam. Upon reception of a propagating ultrasonic wave, each vibrator expands and contracts to produce an electric signal, which is then outputted as reception signal of the ultrasonic wave.

[0019] Under the control of the CPU 10, the transmission/reception selector switch 7 selectively connects the transducer array 6 to one of the preamplifier 8 and the transmission driver 9.

The preamplifier 8 amplifies the reception signals outputted from the respective channels of the ultrasonic transducers of the transducer array 6.

The transmission driver 9 comprises, for example, a plurality of pulse generators and adjusts the delay amounts of drive signals for the respective transducers based on a transmission delay pattern selected by the CPU 10 so that the ultrasonic waves transmitted from the transducer array 6 form a broad ultrasonic beam covering an area of a tissue in the subject and supplies the transducers of the transducer array 6 with the adjusted drive signals. The CPU 10 controls the transmission driver 9 according to various control signals transmitted from the CPU 15 of the middle unit 4 connected via the connector 5.

[0020] The transducer array 6 has a specific frequency band and a specific drive voltage. The preamplifier 8 used has a frequency band corresponding to the frequency band of the transducer array 6. The transmission driver 9 used outputs a drive voltage corresponding to the drive voltage for the transducer array 6.

[0021] The A/D converter 11 digitizes the reception signals amplified by the preamplifier 8.

Under the control of the CPU 15, the reception signal processor 12 subjects the reception signals digitized by the A/D converter 11 to quadrature detection or quadrature sampling to produce complex baseband signals, samples the complex baseband signals to generate sample data containing information on the area of the tissue, and supplies the sample data to the parallel/serial converter 13. Otherwise, the reception signal processor 12 may generate sample data by performing data compression on the data obtained by sampling the complex baseband signals for high-efficiency coding.

The parallel/serial converter 13 converts the parallel sample data generated by the reception signal processor 12 having a plurality of channels into serial sample data.

[0022] The wireless communication unit 14 performs carrier modulation based on the serial sample data to generate transmission signals and supplies an antenna with the transmission signals so that the antenna transmits radio waves thereby to transmit the serial sample data. The modulation methods that may be employed herein include ASK (Amplitude Shift Keying), PSK (Phase Shift Keying), QPSK (Quadrature Phase Shift Keying), and 16QAM (16 Quadrature Amplitude Modulation).

The wireless communication unit 14 transmits the sample data to the back unit 2 and receives various control signals from the back unit 2 through wireless communication with the back unit 2, outputting the received control signals to the CPU 15.

Based on the control signal received from the back unit 2, the CPU 15 transmits a signal to the CPU 10 of the front unit 3 for the control of the transmission driver 9 and controls the wireless communication unit 14 so that sample data may be transmitted at a set transmission radio field intensity.

[0023] The connector 5 detachably connects the front unit 3 and the middle unit 4 and comprises a reception signal line for transmitting reception signals amplified by the preamplifier 8 of the front unit 3 to the A/D converter 11 of the middle unit 4 and a communication line for transmitting signals between the CPU 10 of the front unit 3 and the CPU 15 of the middle unit 4.

The ultrasound probe 1 includes a built-in battery, not shown, which supplies power to the circuits in the front unit 3 and the middle unit 4 in the ultrasound probe 1.

The front unit 3 of the ultrasound probe 1 illustrated in FIG. 1 is compatible with a sector scan mode.

[0024] The back unit 2 includes a wireless communication unit 16. An image forming unit 18 is connected to the wireless communication unit 16 via a serial/parallel converter 17, and a display unit 19 is connected to the image forming unit 18. A CPU 20 is connected to the wireless communication unit 16, the serial/parallel converter 17, and the image forming unit 18. Further, an operating unit 21 for an operator to perform input operations is connected to the CPU 20.

[0025] The wireless communication unit 16 transmits various control signals to the ultrasound probe 1 through wireless communication with the ultrasound probe 1. The wireless communication unit 16 demodulates the signal received by an antenna to output serial sample data.

The serial/parallel converter 17 converts the serial sample data outputted from the wireless communication unit 16 into parallel sample data.

[0026] The image forming unit 18 performs reception focusing on the sample data to generate image signals representing an ultrasound diagnostic image. The image forming unit 18 includes a phasing adder and an image processor.

The phasing adder selects one reception delay pattern from a plurality of previously stored reception delay patterns according to the reception direction that is set by the CPU 20 and, based on the selected reception delay pattern, provides a plurality of complex baseband signals represented by the sample data with their respective delays and adds them up to perform the reception focusing. This reception focusing yields a baseband signal (sound ray signal) where the ultrasonic echo is well focused.

[0027] The image processor generates a B-mode image signal, which is tomographic image information on, for example, a tissue inside the subject, according to the sound ray signal generated by the phasing adder. The

image processor includes an STC (sensitivity time control) unit and a DSC (digital scan converter). The STC unit corrects the sound ray signal for the attenuation due to distance according to the depth of the reflection position of the ultrasonic wave. The DSC converts the sound ray signal corrected by the STC unit into an image signal compatible with an ordinary scanning method of television signals (raster conversion), and generates an image signal through required image processing such as gradation processing.

[0028] The display unit 19 displays an ultrasound diagnostic image based on image signals generated by the image forming unit 18 and includes a display device such as LCD.

Based on the instruction inputted by an operator from the operating unit 21, the CPU 20 controls the wireless communication unit 16 so that various control signals are transmitted at a set transmission radio field intensity, causes the image forming unit 18 to generate image signals, and causes the display unit 19 to display an ultrasound diagnostic image.

[0029] In Embodiment 1, the front unit 3 of the ultrasound probe 1 is detachably connected to the middle unit 4 via the connector 5. Thus, with a plurality of front units 3 including transducer arrays 6 having different frequency bands as well as preamplifiers 8 and transmission drivers 9 corresponding to the transducer arrays 6 available for use, a front unit 3 comprising a transducer array 6 having a suitable frequency band for an intended diagnosis purpose can be selected and connected to the middle unit 4.

[0030] Next, the operation of Embodiment 1 will be described with reference to the flowchart of FIG. 2.

First, examination information including patient information and examination instructions is entered from the operating unit 21 of the back unit 2 in the examination information input mode in step S1, whereupon the CPU 20 of the back unit 2 selects one front unit 3 containing the transducer array 6 having a suitable or usable frequency band according to the entered patient information.

[0031] In step S2 to follow, the CPU 20 of the back unit 2 inquires of the CPU 15 of the middle unit 4 by wireless communication, whereupon the CPU 15 of the middle unit 4 checks with the CPU 10 of the front unit 3, so that the CPU 20 of the back unit 2 may recognize whether or not the front unit 3 selected in step S1 has been connected to the middle unit 4.

[0032] Upon recognizing that the selected front unit 3 has been connected to the middle unit 4, the CPU 20 of the back unit 2 awaits the operator's instruction to start examination in step S3 and, upon receiving the instruction to start examination, proceeds to step S4 to execute an examination mode and, in step S5, awaits the operator's instruction to terminate the examination. When instruction to terminate the examination is entered, a series of examination processes is terminated, whereas when instruction to continue the examination is entered, the CPU 20 returns to step S1 to receive examination infor-

mation again.

[0033] In step S4, one or more of previously set examination modes such as B mode, CF mode, PW mode, and M mode, as shown by way of example in FIG. 3, may be selected and executed. The CPU 20 of the back unit 2 checks examination information entered in step S1 to determine which mode has been designated and, upon verifying designation of B mode in step S11, proceeds to step S12 to execute examination in B mode. Upon verifying designation of CF mode in step S13, the CPU 20 proceeds to step S14 to execute examination in CF mode. Upon verifying designation of PW mode in step S15, the CPU 20 proceeds to step S16 to execute examination in PW mode. Upon verifying designation of M mode in step S17, the CPU 20 proceeds to step S18 to execute examination in M mode. When the termination of examination carried out based on the current examination information is verified in step S19, the CPU 20 proceeds to step S5 shown in FIG. 2.

[0034] The examinations in the respective modes are executed as follows.

First, operation control command is transmitted from the CPU 20 of the back unit 2 to the ultrasound probe 1 via the wireless communication unit 16. The operation control command is received by the wireless communication unit 14 of the middle unit 4 and transmitted to the CPU 15. Then, the CPU 15 outputs a command for driving the transducer array 6 to the CPU 10 of the front unit 3 via the connector 5.

[0035] The CPU 10 of the front unit 3 that received the above command operates the transmission/reception selector switch 7 to connect the transmission driver 9 to the transducer array 6, and the ultrasound transducers constituting the transducer array 6 transmit ultrasonic waves according to drive signals supplied from the transmission driver 9. Thereafter, the CPU 10 causes the transmission/reception selector switch 7 to operate so that the preamplifier 8 is now connected to the transducer array 6, and reception signals outputted respectively from the transducers of the transducer array 6 that received ultrasound echoes from a subject are amplified by the preamplifier 8 and then transmitted to the middle unit 4 via the connector 5.

[0036] The reception signals transmitted to the middle unit 4 are digitized by the A/D converter 11 and supplied to the reception signal processor 12, where sample data is generated. The sample data is serialized through the parallel/serial converter 13 and wirelessly transmitted from the wireless communication unit 14 to the back unit 2.

The sample data received by the wireless communication unit 16 of the back unit 2 is converted into parallel data through the serial/parallel converter 17, whereupon the image forming unit 18 produces an image signal appropriate for the executed examination mode, so that the display unit 19 displays an ultrasound diagnostic image based on the image signal.

[0037] As described above, the front unit 3 detachably

connected to the middle unit 4 incorporates, besides the transducer array 6 having a specific frequency band, the preamplifier 8 having a frequency band corresponding to the frequency band of the transducer array 6 and the transmission driver 9 for outputting a drive voltage corresponding to the drive voltage for the transducer array 6. Thus, one need not employ an over-engineered system configuration, as conventionally required, equipped with a broadband preamplifier having a bandwidth of about, for example, 2 to 20 MHz and enabling operation with a plurality of transducer arrays having different frequency bands and a transmission driver capable of a high drive voltage adapted to a transducer array having a maximum drive voltage among a plurality of transducer arrays. Thus, a compact ultrasound diagnostic apparatus with enhanced operability can be realized.

[0038] Further, in Embodiment 1 above, the front unit 3 and the middle unit 4 are exclusively provided with the CPU 10 and the CPU 15 respectively, so that the CPU 10 controls the components in the front unit 3 while the CPU 15 controls the components in the middle unit 4. Thus, the number of control signal lines for connecting the front unit 3 and the middle unit 4 can be reduced, and both units can be detachably connected by a compact connector 5.

Embodiment 2

[0039] Although the front unit 3 of the ultrasound probe 1 used in Embodiment 1 above is compatible with a sector scan mode, the invention is not limited thereto. The front unit 3 may be compatible with other scan modes including, for example, a linear scan mode and a convex scan mode.

FIG. 4 illustrates a configuration of a front unit 31 used in Embodiment 2. As compared with the front unit 3 in Embodiment 1 illustrated in FIG. 1, the front unit 31 has a multiplexer 32 connected between the transducer array 6 and the transmission/reception selector switch 7 to acquire compatibility with the linear scan mode and the convex scan mode.

[0040] Under the control of the CPU 10, some transducers among those constituting the transducer array 6 are sequentially selected and perform transmission and reception of ultrasonic waves. This enables acquisition of an ultrasound diagnostic image by the linear scan mode or the convex scan mode.

When equipped with both the front unit 3 compatible with the sector scan mode as illustrated in FIG. 1 and the front unit 31 compatible with the linear scan mode and the convex scan mode as used in Embodiment 2, one may select one of these front units according to the scan mode and connect it to the middle unit 4.

Embodiment 3

[0041] FIG. 5 illustrates a configuration of a front unit 41 used in an ultrasound diagnostic apparatus according

to Embodiment 3. As compared with the front unit 3 in Embodiment 1 illustrated in FIG. 1, the front unit 41 does not have the transmission/reception selector switch 7, and in place of the transducer array 6, has a reception transducer array 42 for only reception connected to the preamplifier 8 and a transmission transducer array 43 for only transmission connected to the transmission driver 9. The front unit 41 is compatible with the sector scan mode.

[0042] Because the reception transducer array 42 dedicated to reception and the transmission transducer array 43 dedicated to transmission are provided, cross talk occurring in transmission of ultrasonic waves can be prevented and ultrasound diagnosis can be given with enhanced accuracy.

[0043] Although the front unit 41 illustrated in FIG. 5 is compatible with the sector scan mode, the invention is not so limited; as in a front unit 51 illustrated in FIG. 6, a front unit compatible with the linear scan mode and the convex scan mode may be configured by connecting a multiplexer 52 between the reception transducer array 42 and the preamplifier 8 and connecting a multiplexer 53 between the transmission transducer array 43 and the transmission driver 9.

Embodiment 4

[0044] FIG. 7 illustrates a configuration of a front unit 61 used in an ultrasound diagnostic apparatus according to Embodiment 4. As compared with the front unit 3 in Embodiment 1 illustrated in FIG. 1, the front unit 61 has a harmonic component reception transducer array 62 connected to the preamplifier 8 in addition to the transducer array 6 used for both transmission and reception. The front unit 61 is compatible with the sector scan mode.

[0045] The harmonic component reception transducer array 62 is a transducer array having a frequency band especially adapted to harmonic components. With such a harmonic component reception transducer array 62 provided, a harmonic component can be received by the harmonic component reception transducer array 62 while an ultrasonic echo in a basic frequency band is received by the transducer array 6 that is used for both transmission and reception, enabling a still more accurate ultrasound diagnosis.

[0046] Although the front unit 61 illustrated in FIG. 7 is compatible with the sector scan mode, the invention is not so limited; as in a front unit 71 illustrated in FIG. 8, a front unit compatible with the linear scan mode and the convex scan mode may be configured by connecting a multiplexer 72 between the transducer array 6 used for both transmission and reception and the transmission/reception selector switch 7 and connecting a multiplexer 73 between the harmonic component reception transducer array 62 and the preamplifier 8.

Embodiment 5

[0047] FIG. 9 illustrates a configuration of a middle unit

81 used in an ultrasound diagnostic apparatus according to Embodiment 5. As compared with the middle unit 4 in Embodiment 1 illustrated in FIG. 1, the middle unit 81 has an operating unit 82 for performing input operation into the ultrasound diagnostic apparatus and a display unit 83 for displaying information, both of which are connected to the CPU 15.

[0048] With the operating unit 82 provided in the middle unit 81 of the ultrasound probe 1, various kinds of information may be entered from the ultrasound probe 1 connected to the back unit 2 by wireless communication to operate the ultrasound diagnostic apparatus from the ultrasound probe 1.

Further with the display unit 83 provided in the middle unit 81 of the ultrasound probe 1, such information as a name and a kind of the front unit connected to the middle unit 81 through the connector 5 can be displayed on the ultrasound probe 1, enhancing operability and convenience.

Although Embodiment 5 includes both the operating unit 82 and the display unit 83 in the middle unit 81, only one of the operating unit 82 and the display unit 83 may be connected to the CPU 15 of the middle unit 81.

REFERENCE SIGNS LIST

[0049] 1 ultrasound probe; 2 back unit; 3, 31, 41, 51, 61, 71 front unit; 4, 81 middle unit; 5 connector; 6 transducer array; 7 transmission/reception selector switch; 8 preamplifier; 9 transmission driver; 10, 15, 20 CPU; 11 A/D converter; 12 reception signal processor; 13 parallel/serial converter; 14, 16 wireless communication unit; 17 serial/parallel converter; 18 image forming unit; 19, 83 display unit; 21, 82 operating unit; 32, 52, 53, 72, 73 multiplexer; 42 reception transducer array; 43 transmission transducer array; 62 harmonic component reception transducer array.

Claims

1. An ultrasound diagnostic apparatus in which an ultrasound probe and a back unit are connected to each other by wireless communication, an ultrasonic beam being transmitted from a transducer array of the ultrasound probe to a subject, the back unit generating an ultrasound image based on reception signals outputted from the transducer array of the ultrasound probe having received an ultrasonic echo from the subject, wherein the ultrasound probe includes a middle unit connected to the back unit by wireless communication and a front unit detachably connected to the middle unit and including the transducer array, and wherein the front unit has a transmission driver that supplies drive signals to the transducer array and causes the transducer array to transmit an ultrasonic beam and a preamplifier that amplifies reception sig-

nals outputted from the transducer array.

2. The ultrasound diagnostic apparatus according to Claim 1, wherein the front unit and the middle unit comprise dedicated CPUs and are detachably connected to each other through a connector that includes a reception signal line for transmitting reception signals amplified by the preamplifier of the front unit and a communication line for transmitting signals between both CPUs.
3. The ultrasound diagnostic apparatus according to Claim 1 or 2, wherein the front unit comprises a multiplexer connected to the transducer array.
4. The ultrasound diagnostic apparatus according to any one of Claims 1 to 3, wherein the transducer array comprises a transmission transducer array dedicated to transmission and a reception transducer array dedicated to reception.
5. The ultrasound diagnostic apparatus according to any one of Claims 1 to 3, wherein the transducer array comprises a dual-purpose transducer array for transmission and reception and a harmonic transducer array for harmonic component reception.
6. The ultrasound diagnostic apparatus according to any one of Claims 1 to 5, wherein the middle unit comprises an A/D converter converting reception signals amplified by the preamplifier of the front unit into a digital signal, a reception signal processor frequency-modulating the digital signal obtained through conversion by the A/D converter to a base-band frequency, and a parallel/serial converter serializing the signal that is frequency-modulated by the reception signal processor.
7. The ultrasound diagnostic apparatus according to any one of Claims 1 to 6, wherein the middle unit comprises at least one of an operating unit performing input operation into the ultrasound diagnostic apparatus and a display unit displaying information.

FIG. 1

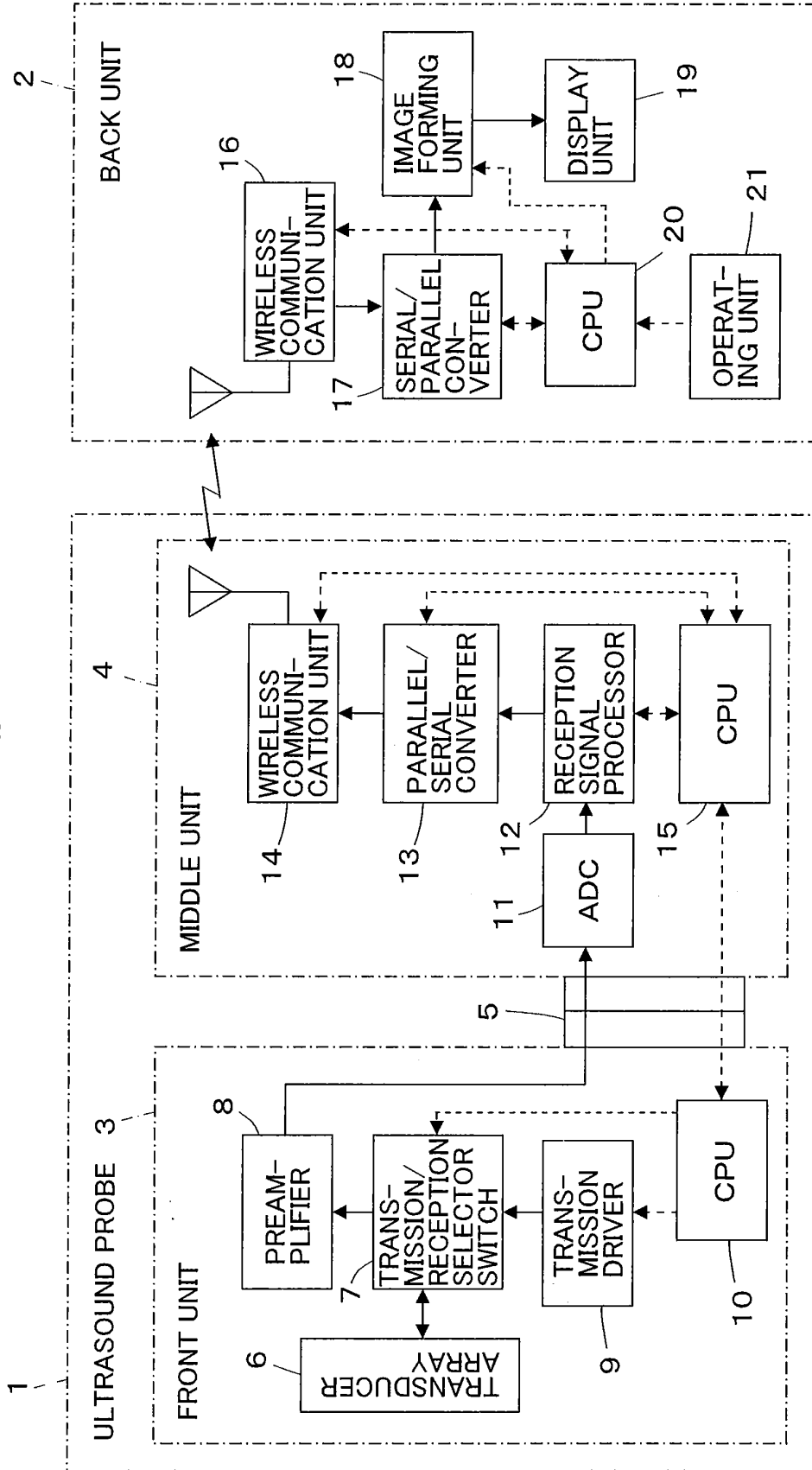

FIG. 2

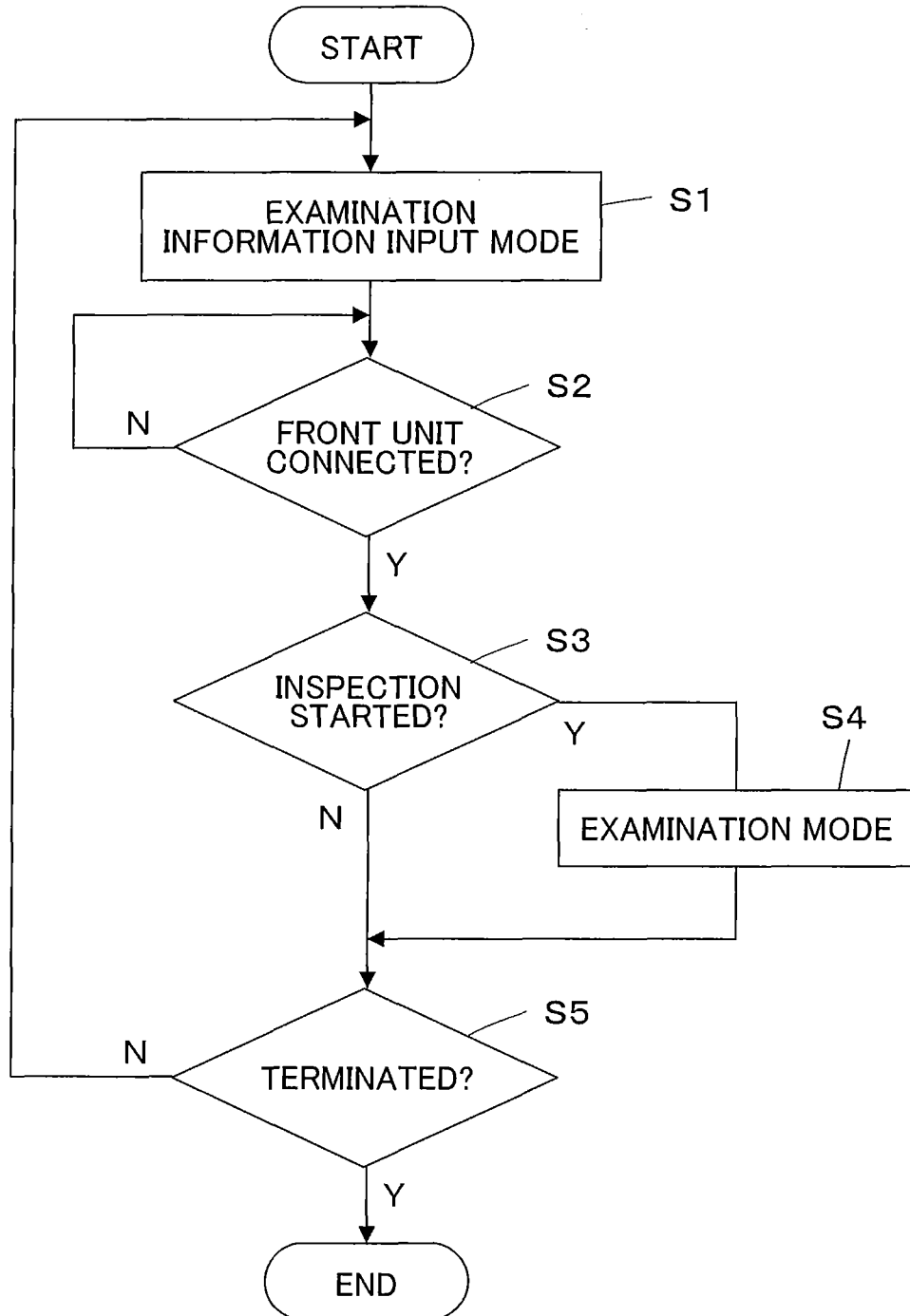

FIG. 3

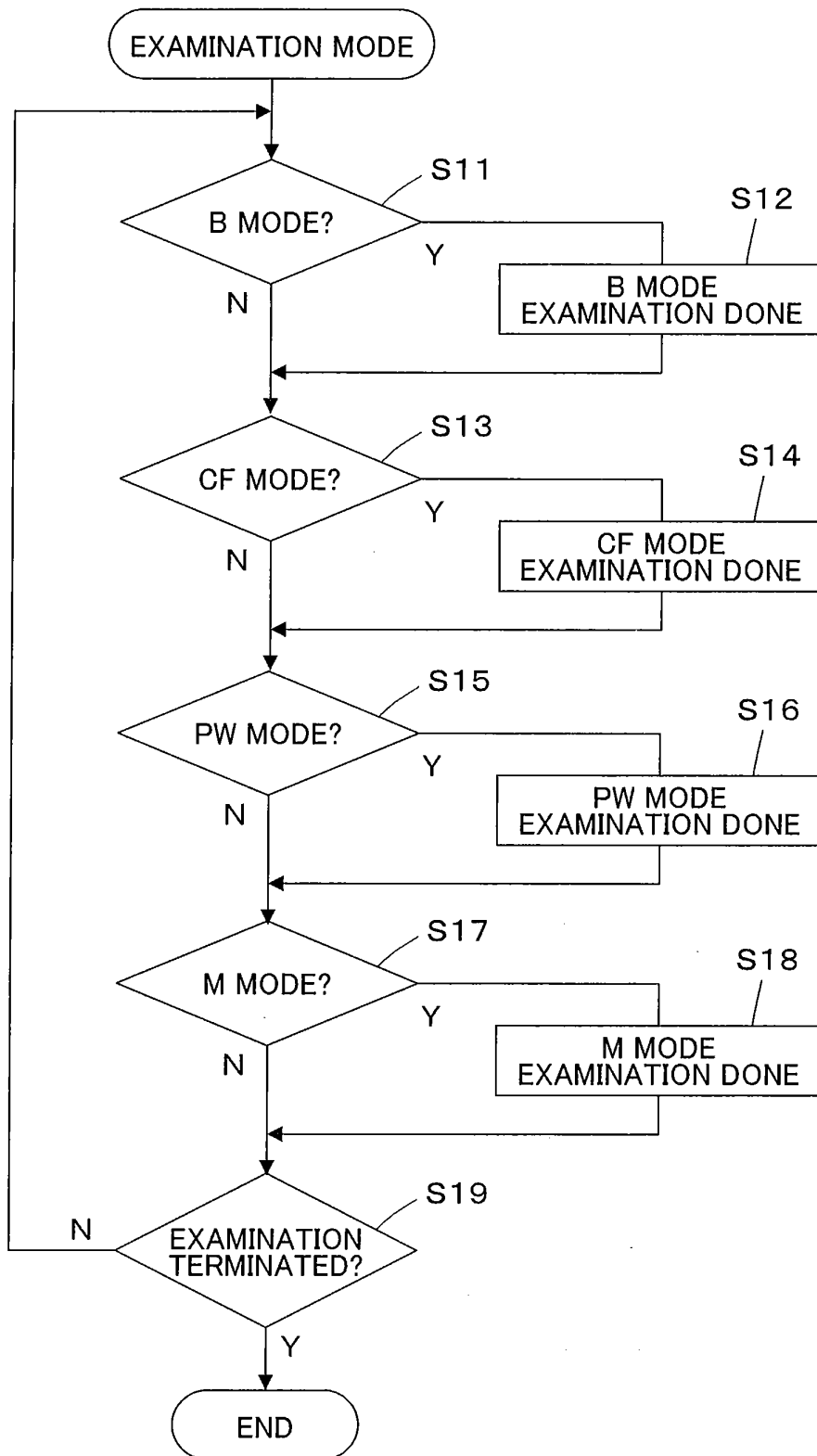

FIG. 4

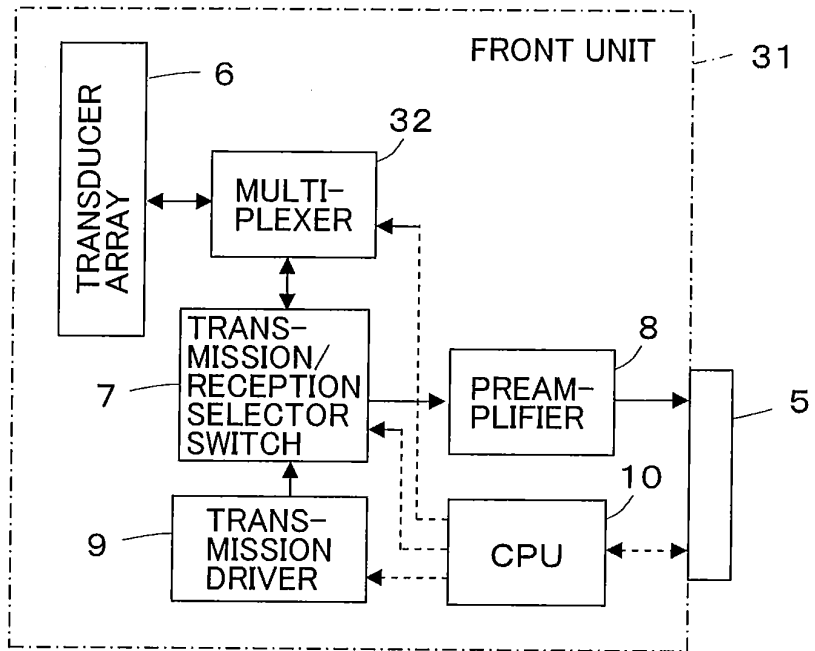

FIG. 5

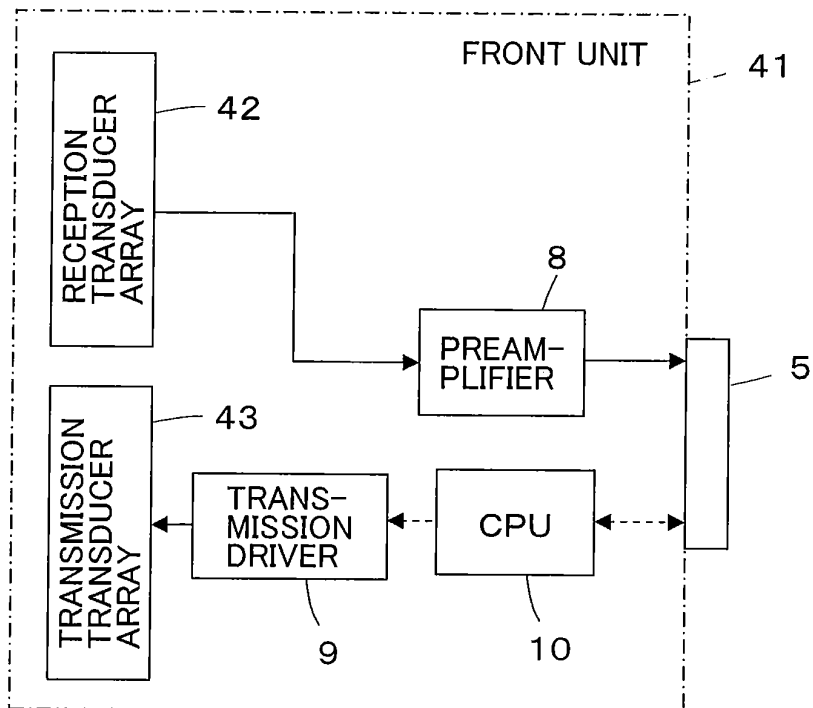

FIG. 6

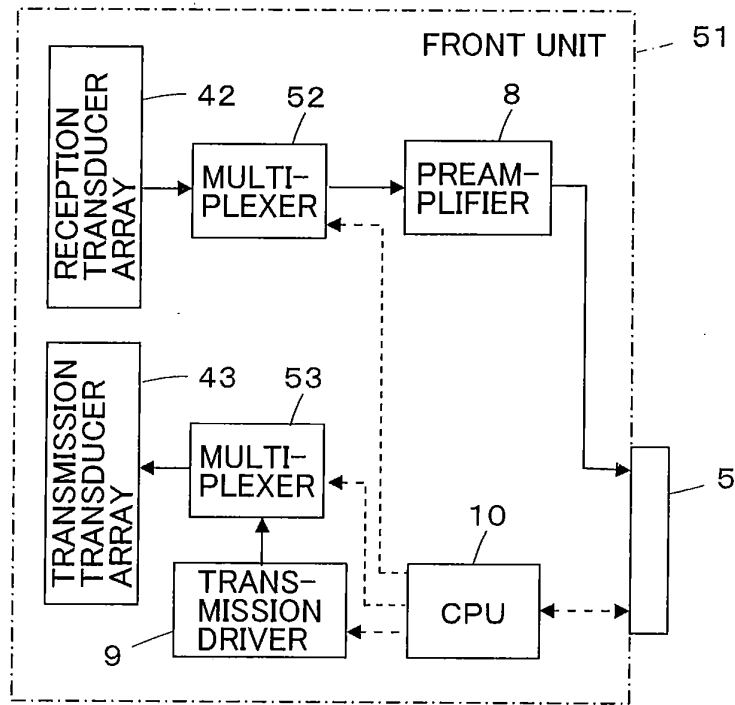

FIG. 7

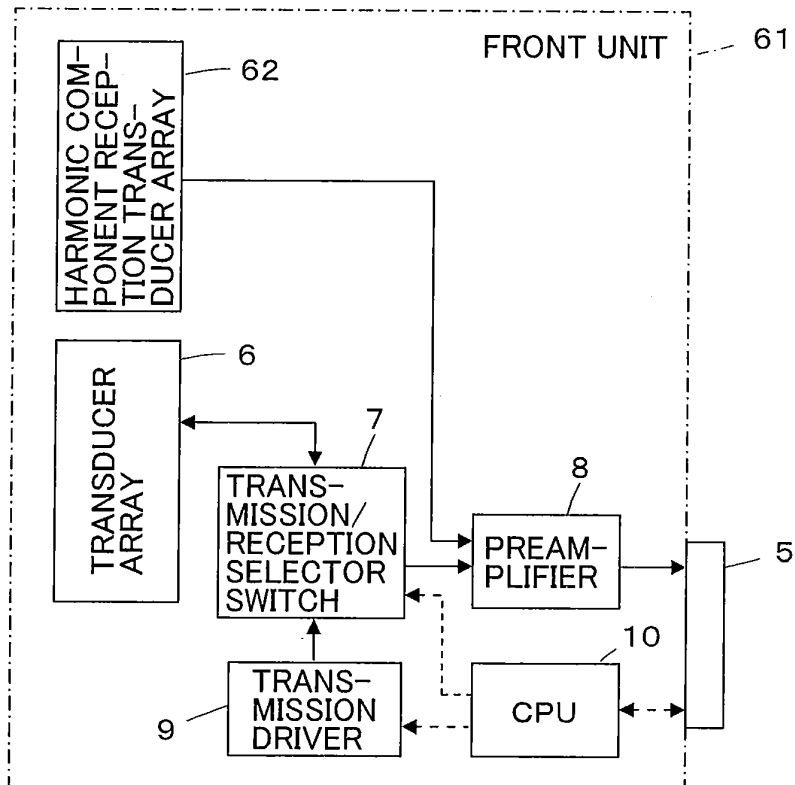

FIG. 8

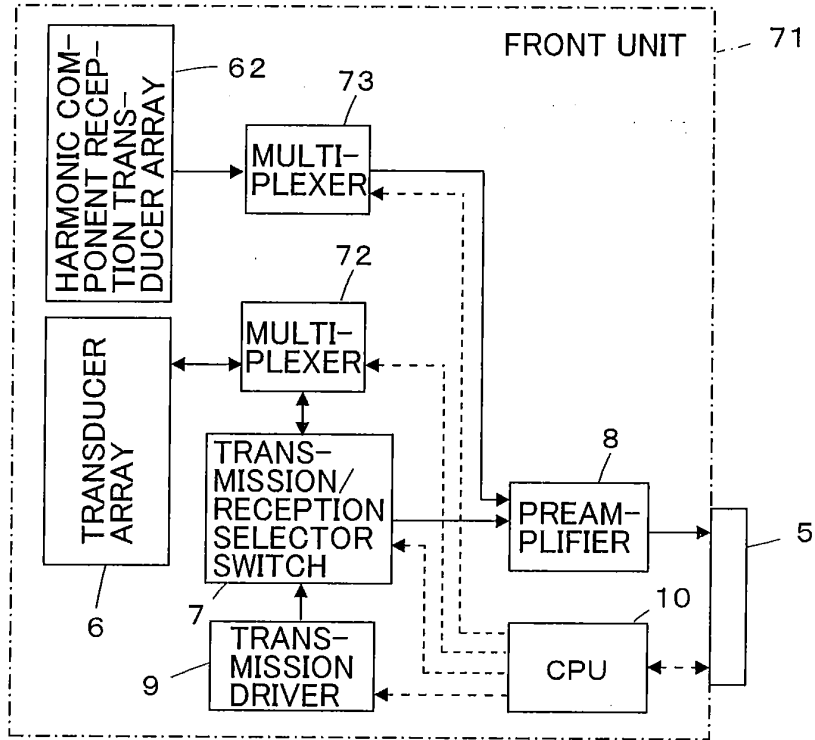
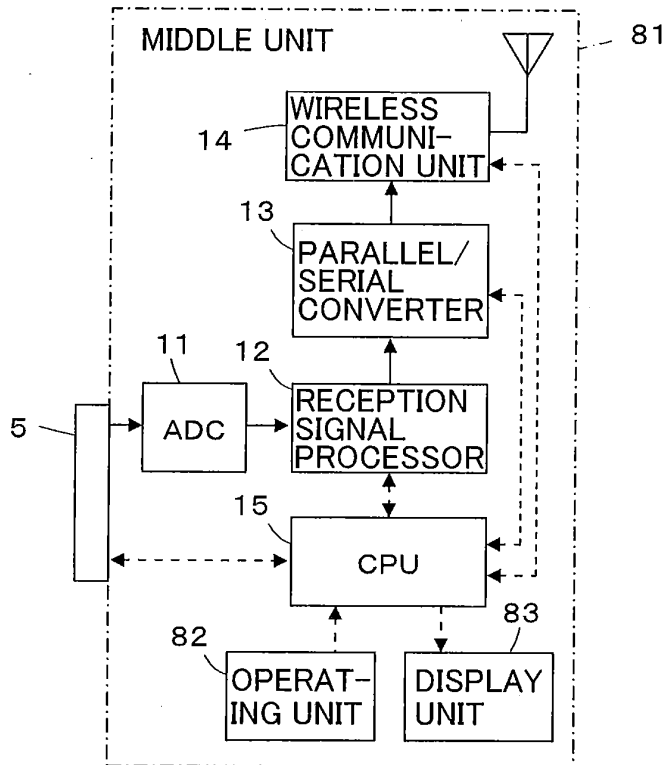

FIG. 9



INTERNATIONAL SEARCH REPORT

International application No.

PCT/JP2011/065944

A. CLASSIFICATION OF SUBJECT MATTER A61B8/00 (2006.01) i		
According to International Patent Classification (IPC) or to both national classification and IPC		
B. FIELDS SEARCHED		
Minimum documentation searched (classification system followed by classification symbols) A61B8/00		
Documentation searched other than minimum documentation to the extent that such documents are included in the fields searched Jitsuyo Shinan Koho 1922-1996 Jitsuyo Shinan Toroku Koho 1996-2011 Kokai Jitsuyo Shinan Koho 1971-2011 Toroku Jitsuyo Shinan Koho 1994-2011		
Electronic data base consulted during the international search (name of data base and, where practicable, search terms used)		
C. DOCUMENTS CONSIDERED TO BE RELEVANT		
Category*	Citation of document, with indication, where appropriate, of the relevant passages	Relevant to claim No.
X Y	JP 2007-190066 A (Aloka Co., Ltd.), 02 August 2007 (02.08.2007), paragraphs [0021] to [0035], [0040] to [0050], [0057] to [0061]; fig. 3 to 7 (Family: none)	1, 2, 6, 7 3-5
Y	JP 2010-374 A (Siemens Medical Solutions USA, Inc.), 07 January 2010 (07.01.2010), paragraphs [0020] to [0022]; fig. 1 & US 2004/0002435 A1 & US 2004/0000841 A1 & DE 10328827 A & DE 10336101 A & CN 1478440 A & CN 101051084 A	3
<input checked="" type="checkbox"/> Further documents are listed in the continuation of Box C. <input type="checkbox"/> See patent family annex.		
* Special categories of cited documents:		
"A"	document defining the general state of the art which is not considered to be of particular relevance	"I" later document published after the international filing date or priority date and not in conflict with the application but cited to understand the principle or theory underlying the invention
"E"	earlier application or patent but published on or after the international filing date	"X" document of particular relevance; the claimed invention cannot be considered novel or cannot be considered to involve an inventive step when the document is taken alone
"L"	document which may throw doubts on priority claim(s) or which is cited to establish the publication date of another citation or other special reason (as specified)	"Y" document of particular relevance; the claimed invention cannot be considered to involve an inventive step when the document is combined with one or more other such documents, such combination being obvious to a person skilled in the art
"O"	document referring to an oral disclosure, use, exhibition or other means	"&" document member of the same patent family
"P"	document published prior to the international filing date but later than the priority date claimed	
Date of the actual completion of the international search 15 August, 2011 (15.08.11)	Date of mailing of the international search report 23 August, 2011 (23.08.11)	
Name and mailing address of the ISA/ Japanese Patent Office	Authorized officer	
Facsimile No.	Telephone No.	

INTERNATIONAL SEARCH REPORT

International application No.
PCT/JP2011/065944

C (Continuation). DOCUMENTS CONSIDERED TO BE RELEVANT		
Category*	Citation of document, with indication, where appropriate, of the relevant passages	Relevant to claim No.
Y	JP 2009-297326 A (Konica Minolta Medical & Graphic, Inc.), 24 December 2009 (24.12.2009), paragraph [0059]; fig. 3, 4 (Family: none)	4
Y	JP 11-276478 A (Fujitsu Ltd.), 12 October 1999 (12.10.1999), paragraph [0015] (Family: none)	6

Form PCT/ISA/210 (continuation of second sheet) (July 2009)

REFERENCES CITED IN THE DESCRIPTION

This list of references cited by the applicant is for the reader's convenience only. It does not form part of the European patent document. Even though great care has been taken in compiling the references, errors or omissions cannot be excluded and the EPO disclaims all liability in this regard.

Patent documents cited in the description

- JP 2003190159 A [0006]
- JP 2009060992 A [0006]

专利名称(译)	超声诊断设备		
公开(公告)号	EP2614775A4	公开(公告)日	2016-06-01
申请号	EP2011823328	申请日	2011-07-13
[标]申请(专利权)人(译)	富士胶片株式会社		
申请(专利权)人(译)	富士胶片株式会社		
当前申请(专利权)人(译)	富士胶片株式会社		
[标]发明人	SATOH YOSHIAKI		
发明人	SATOH, YOSHIAKI		
IPC分类号	A61B8/00		
CPC分类号	A61B8/4472 A61B8/4411 A61B8/4477 A61B8/4494 G01S7/003 G01S7/5208 G01S7/52082 G01S7/52098 G01S15/8913 G01S15/8915		
优先权	2010198566 2010-09-06 JP		
其他公开文献	EP2614775B1 EP2614775A1		
外部链接	Espacenet		

摘要(译)

本发明提供一种超声波诊断装置，其允许换能器阵列的交换以选择具有适当频带的换能器阵列用于预期的诊断目的，同时实现尺寸的减小和操作的简易性。超声探头1包括通过无线通信连接到后单元2的中间单元4，以及通过连接器5可拆卸地连接到中间单元4的前单元3。前单元3包括具有特定频带的换能器阵列6，前置放大器8具有与换能器阵列6的频带对应的频带，以及发送驱动器9，其输出与换能器阵列6的驱动电压对应的驱动电压。前单元3，中间单元4和后单元2分别具有专用CPU 10,15和20，用于控制各个单元中的组件。