



Europäisches Patentamt
European Patent Office
Office européen des brevets



(11) **EP 1 709 908 A1**

(12) **EUROPEAN PATENT APPLICATION**
published in accordance with Art. 158(3) EPC

(43) Date of publication:
11.10.2006 Bulletin 2006/41

(51) Int Cl.:
A61B 8/00 (2006.01)

(21) Application number: **05703342.5**

(86) International application number:
PCT/JP2005/000074

(22) Date of filing: **06.01.2005**

(87) International publication number:
WO 2005/065547 (21.07.2005 Gazette 2005/29)

(84) Designated Contracting States:
DE

(30) Priority: **08.01.2004 JP 2004003310**

(71) Applicant: **MATSUSHITA ELECTRIC INDUSTRIAL CO., LTD.**
Osaka 571-8501 (JP)

(72) Inventors:
• **UCHIKAWA, Akiko**
c/o Matsushita Elect.Ind.Co. Ltd.
chome,Chuo-ku,Osaka-shi,Osaka 540-6319 (JP)

• **ITO, Yoshihiko**
c/o Matsushita Elect.Ind.Co. Ltd.
chome,Chuo-ku,Osaka-shi,Osaka 540-6319 (JP)
• **NAKAMURA, Yasuhiro**
c/o Matsushita Elect.Ind.Co.Ltd
chome,Chuo-ku,Osaka-shi,Osaka 540-6319 (JP)

(74) Representative: **Schorr, Frank Jürgen et al**
Diehl & Partner GbR
Augustenstrasse 46
80333 München (DE)

(54) **ULTRASONIC DIAGNOSIS APPARATUS**

(57) There is provided first storage means (3) for storing digital reception beam data converted from a reception beam formed from an ultrasonic received signal; first control means (2) for controlling reading and writing of data from/in the first storage means; a filter coefficient calculation portion (5) for calculating a filter coefficient based on information on the reception beam, the information including a positional relationship between the reception beam and a transmission beam; and a first spatial filter operation portion (4) for subjecting each of a plurality of the reception beam data including data of beams received in parallel from a single transmission beam to filtering processing for reducing a difference in image quality between adjacent beams based on the filter coefficient. Image data output from the first spatial filter operation portion are converted into scanning of a display monitor (8) so as to display an image on the display monitor. In an ultrasonic diagnosis apparatus having a parallel reception function, it is possible to display a high-quality ultrasonic image in which stripes are generated less in a direction in which acoustic lines are arranged and that is well defined in detail.

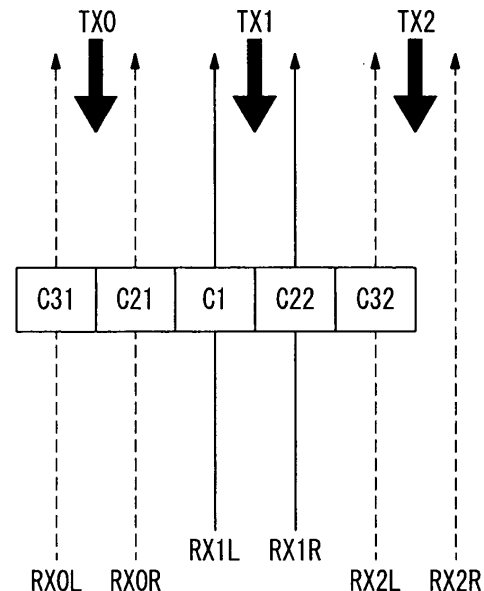

FIG. 4B

EP 1 709 908 A1

Description

Technical Field

5 **[0001]** The present invention relates to an ultrasonic diagnosis apparatus having a parallel reception function of forming a plurality of reception beams from a single transmission beam.

Background Art

10 **[0002]** As shown in FIG. 13, an ultrasonic diagnosis apparatus obtains two-dimensional information by scanning ultrasonic beams with an ultrasonic probe 30 for transmitting and receiving ultrasonic waves to/from a subject, and displays an ultrasonic image based on the two-dimensional information. A signal received by the ultrasonic probe 30 is supplied to a spatial filter processing circuit 32 through a signal processing portion 31.

15 The spatial filter processing circuit 32, which is provided before an image display conversion portion 33, includes a spatial filter for reducing noise in the received signal. A control circuit 34 controls the spatial filter processing circuit 32 so that a filter coefficient is changed in a direction from the vicinity of a surface of an oscillator toward a distal point in acoustic data. In other words, according to the conventional ultrasonic diagnosis apparatus, in spatial filter processing of the acoustic data before coordinate transformation, the filter coefficient is changed in accordance with a distance on the acoustic line data (see, for example, Patent document 1).

20 Patent document 1: JP 2001-340338 A (FIG. 1)

Disclosure of Invention

Problem to be Solved by the Invention

25 **[0003]** In the conventional ultrasonic diagnosis apparatus, a signal difference between a plurality of reception beams that are obtained from a single transmission beam with a parallel reception function is smaller than a signal difference between reception beams obtained from different transmission beams. Therefore, when the filter coefficient for reducing a difference in image quality between adjacent beams is fixed, there arise the following problems. That is, between
30 signals of reception beams obtained from a single transmission beam, the filter works excessively, and thus an image is made uniform due to a smoothing effect and detail of the image cannot be displayed. On the other hand, between signals of reception beams obtained from different transmission beams, the filter hardly works, and thus boundaries between the reception beams are displayed due to the effect of edge reinforcement.

35 **[0004]** In particular, in two-dimensional Doppler, transmission and reception are repeated about ten times on the same acoustic line so as to detect a temporal variation, and therefore a large amount of time elapses between different transmission beams. Accordingly, there is a significant variation between reception beams obtained from a single transmission beam and reception beams obtained from different transmission beams. This noticeably results in a uniform image or visible boundaries between the reception beams, causing stripes to be generated in a direction in which acoustic lines are arranged. Moreover, in two-dimensional Doppler, when a temporal variation is indicated by coloring, a boundary
40 between a non-colored portion where a temporal variation is zero and a colored portion where a temporal variation occurs is shown clearly, and therefore stripes are generated in the direction of acoustic lines depending upon the presence/absence of data.

45 **[0005]** The present invention has been made to solve the above-mentioned conventional problems, and its object is to provide an ultrasonic diagnosis apparatus that optimizes filtering processing with respect to signals between a plurality of reception beams obtained from a single transmission beam, thereby displaying a high-quality ultrasonic image in which stripes are generated less in a direction in which acoustic lines are arranged and that is well defined in detail.

Means for Solving Problem

50 **[0006]** In order to achieve the above-mentioned object, an ultrasonic diagnosis apparatus according to the present invention includes: first storage means (memory) for storing digital reception beam data converted from a reception beam formed from an ultrasonic received signal; first control means (memory control portion, first memory control portion) for controlling reading and writing of data from/in the first storage means; a filter coefficient calculation portion for calculating a filter coefficient based on information on the reception beam, the information including a positional relationship between the reception beam and a transmission beam; and a first spatial filter operation portion for subjecting
55 each of a plurality of the reception beam data including data of beams received in parallel from a single transmission beam to filtering processing for reducing a difference in image quality between adjacent beams based on the filter coefficient, wherein image data output from the first spatial filter operation portion are converted into scanning of a display

monitor so as to display an image on the display monitor.

[0007] With this configuration, the filter coefficients can be controlled optimally with respect to signals between a plurality of the reception beams including ones received in parallel from a single transmission beam, in accordance with a position of each of the reception beams with respect to a transmission beam. As a result, it becomes possible to display a high-quality ultrasonic image in which stripes are generated less in a direction in which acoustic lines are arranged and that is well defined in detail.

[0008] The ultrasonic diagnosis apparatus with the above configuration further can include: a two-dimensional Doppler signal processing portion for subjecting reception beam data from an ultrasonic reception data processing portion to two-dimensional Doppler processing; second storage means (two-dimensional Doppler memory) for storing two-dimensional Doppler data output from the two-dimensional Doppler signal processing portion; second control means (second memory control portion) for controlling reading and writing of data from/in the second storage means; and a second spatial filter operation portion for subjecting each of a plurality of the received two-dimensional Doppler data including data of beams received in parallel from a single transmission beam to filtering processing for reducing a difference in image quality between adjacent beams based on the filter coefficient supplied from the filter coefficient calculation portion.

[0009] With this configuration, in the ultrasonic diagnosis apparatus having the two-dimensional Doppler function, the filter coefficients can be controlled optimally with respect to signals between a plurality of the reception beams including ones received in parallel from a single transmission beam, in accordance with a position of each of the reception beams with respect to a transmission beam. As a result, it becomes possible to display a high-quality ultrasonic image that is well defined in detail with reduced noticeable stripes seen in two-dimensional Doppler in a direction in which acoustic lines are arranged.

[0010] In the ultrasonic diagnosis apparatus with the above configuration, it is possible that the filter coefficient calculation portion is able to control the filter coefficient in accordance with a receiving depth.

[0011] With this configuration, in the case where a distance between acoustic lines is different depending upon the depth, filter coefficients of stronger correlation can be set for a shallow portion, and filter coefficients of weaker correlation can be set for a deep portion. As a result, it is possible to display a high-quality ultrasonic image with little lateral shift.

[0012] In the ultrasonic diagnosis apparatus with the above configuration, it is possible that the filter coefficient calculation portion is able to control the filter coefficient in accordance with an angle of the reception beam.

[0013] With this configuration, in the case where transmission and reception are performed with angled acoustic lines, the filter coefficients can be optimized such that, for example, filter coefficients of weak correlation are set between the same depths. As a result, it is possible to display a high-quality ultrasonic image with little lateral shift. Further, in the case where a deflection angle is different depending upon the acoustic line, the optimization of the filter coefficients allows beam distortion to be corrected.

[0014] In the ultrasonic diagnosis apparatus with the above configuration, it is possible that the filter coefficient calculation portion is able to control the filter coefficient in accordance with a focal position of the transmission beam.

[0015] With this configuration, the filter coefficients can be optimized such that, for example, filter coefficients of weak correlation are set for the vicinity of the focal position of the transmission beam, and filter coefficients of strong correlation are set for positions away from the focal position of the transmission beam. As a result, it is possible to display a high-quality ultrasonic image that is uniform regardless of the focal position of the transmission beam.

Effects of the Invention

[0016] According to the present invention, it is possible to achieve a particular effect of providing an ultrasonic diagnosis apparatus that optimizes filtering processing with respect to signals between a plurality of reception beams obtained from a single transmission beam, thereby displaying a high-quality ultrasonic image in which stripes are generated less in a direction in which acoustic lines are arranged and that is well defined in detail.

Brief Description of Drawings

[0017] [FIG. 1] FIG. 1 is a functional block diagram showing an exemplary configuration of an ultrasonic diagnosis apparatus according to a first embodiment of the present invention.

[FIG. 2A] FIG. 2A is a schematic diagram showing image data at an arbitrary depth in the case where each single reception beam is formed from a single transmission beam and where a lateral filter is used in the first embodiment.

[FIG. 2B] FIG. 2B is a schematic diagram showing filter coefficients corresponding to the image data in FIG. 2A.

[FIG. 3A] FIG. 3A is a schematic diagram showing image data at an arbitrary depth in the case where each single reception beam is formed from a single transmission beam and where a diamond-shaped filter is used in the first embodiment.

[FIG. 3B] FIG. 3B is a schematic diagram showing filter coefficients corresponding to the image data in FIG. 3A.

[FIG. 4A] FIG. 4A is a schematic diagram showing image data at an arbitrary depth in the case where two reception beams are formed from a single transmission beam and where a lateral filter is used in the first embodiment.

[FIG. 4B] FIG. 4B is a schematic diagram showing filter coefficients for forming data "OutL" at an arbitrary sampling point on a reception beam RX1L from the image data in FIG. 4A.

5 [FIG. 4C] FIG. 4C is a schematic diagram showing filter coefficients for forming data "OutR" at an arbitrary sampling point on a reception beam RX1R from the image data in FIG. 4A.

[FIG. 5A] FIG. 5A is a schematic diagram showing image data at an arbitrary depth in the case where two reception beams are formed from a single transmission beam and where a diamond-shaped filter is used in the first embodiment.

10 [FIG. 5B] FIG. 5B is a schematic diagram showing filter coefficients for forming data "OutL" at an arbitrary sampling point on a reception beam RX1L from the image data in FIG. 5A.

[FIG. 5C] FIG. 5C is a schematic diagram showing filter coefficients for forming data "OutR" at an arbitrary sampling point on a reception beam RX1R from the image data in FIG. 5A.

[FIG. 6] FIG. 6 is a functional block diagram showing an exemplary configuration of an ultrasonic diagnosis apparatus according to a second embodiment of the present invention.

15 [FIG. 7] FIG. 7 is a functional block diagram showing an exemplary configuration of an ultrasonic diagnosis apparatus according to a third embodiment of the present invention.

[FIG. 8] FIG. 8 is a schematic diagram for explaining a function of controlling filter coefficients in the case where a distance between acoustic lines is different depending upon the depth in the third embodiment.

20 [FIG. 9] FIG. 9 is a functional block diagram showing an exemplary configuration of an ultrasonic diagnosis apparatus according to a fourth embodiment of the present invention.

[FIG. 10A] FIG. 10A is a schematic diagram for explaining a function of controlling filter coefficients in the case where transmission and reception are performed with angled acoustic lines in the fourth embodiment.

[FIG. 10B] FIG. 10B is a schematic diagram for explaining a function of controlling filter coefficients in the case where a deflection angle is different depending upon the acoustic line in the fourth embodiment.

25 [FIG. 11] FIG. 11 is a functional block diagram showing an exemplary configuration of an ultrasonic diagnosis apparatus according to a fifth embodiment of the present invention.

[FIG. 12] FIG. 12 is a schematic diagram for explaining a function of controlling filter coefficients in accordance with a focal position of a transmission beam in the fifth embodiment.

30 [FIG. 13] FIG. 13 is a functional block diagram showing an exemplary configuration of a conventional ultrasonic diagnosis apparatus.

Explanation of Letters or Numerals

[0018]

35

- 1 Ultrasonic reception data processing portion
- 2 Memory (first storage means)
- 3 Memory control portion, first memory control portion (first control means)
- 4 Spatial filter operation portion, first spatial filter operation portion
- 40 5, 16, 19, 23 Filter coefficient calculation portion
- 6 Acoustic beam control portion
- 7 Scanning conversion portion
- 8 Monitor (display means)
- 9, 15, 16 Spatial filter
- 45 10 Brightness signal processing portion
- 11 Two-dimensional Doppler signal processing portion
- 12 Two-dimensional Doppler memory (second storage means)
- 13 Second memory control portion (second control means)
- 14 Second spatial filter operation portion
- 50 17 Depth information generation portion
- 18, 21, 22 Acoustic line
- 20 Beam angle information generation portion
- 24 Transmission beam focal position information generation portion

55

Description of the Invention

[0019] Hereinafter, preferred embodiments of the present invention will be described in detail with reference to the drawings.

(First Embodiment)

[0020] FIG. 1 is a functional block diagram showing an exemplary configuration of an ultrasonic diagnosis apparatus according to a first embodiment of the present invention.

[0021] This ultrasonic diagnosis apparatus includes an ultrasonic reception data processing portion 1 for forming a reception beam of an ultrasonic received signal and converting the reception beam into digital reception beam data, a spatial filter 9, an acoustic beam control portion 6 for supplying information on the reception beam to the ultrasonic reception data processing portion 1, a scanning conversion portion 7 for converting output data from the spatial filter 9 into image data, and a monitor 8 (display means) for displaying the image data.

[0022] The spatial filter 9 includes memories 3 (first storage means) for storing the reception beam data supplied from the ultrasonic reception data processing portion 1, a memory control portion 2 (first control means) for controlling reading and writing of data from/in the memories 3, a spatial filter operation portion 4 (first spatial filter operation portion) for subjecting data read by the memory control portion 2 to filtering processing, and a filter coefficient calculation portion 5 for calculating a filter coefficient and supplying the same to the spatial filter operation portion 4.

[0023] The filter coefficient calculation portion 5 calculates the filter coefficient based on the information on the reception beam, the information including a positional relationship between the reception beam and a transmission beam. The positional relationship between the reception beam and a transmission beam is, for example, information on whether or not the reception beams are formed from a single transmission beam. The spatial filter operation portion 4 subjects a plurality of the reception beam data to filtering processing for reducing a difference in image quality between adjacent beams, based on the filter coefficients supplied from the filter coefficient calculation portion 5, and supplies the resultant output data to the scanning conversion portion 7. The information on the reception beam may be supplied directly to the memory control portion 2 and the filter coefficient calculation portion 5.

[0024] Next, an operation of the ultrasonic diagnosis apparatus thus configured will be described with reference to FIGs. 2A, 2B, 3A, 3B, 4A to 4C, and 5A to 5C. In particular, a description will be given mainly of the spatial filter 9 as a principal component of the present invention.

[0025] In the present embodiment, when a plurality of reception beams are formed from a single transmission beam, the filter coefficients are not set in a bilaterally symmetrical manner but are set to values that allow a difference in correlation between image data to be canceled. More specifically, image data on a plurality of reception beams formed from a single transmission beam are multiplied by small filter coefficients, since such image data show a strong correlation with each other. On the other hand, image data on reception beams formed from different reception beams are multiplied by large filter coefficients. By setting the filter coefficients in this manner, a possible difference in image quality between adjacent beams is reduced. The following description is directed to such filtering processing.

[0026] First, with reference to FIGs. 2A and 2B, a description will be given of the filtering processing for reducing a difference in image quality between adjacent beams in the case where each single reception beam is formed from a single transmission beam and where, for example, a lateral filter is used. This processing is carried out in the same manner as in the prior art. FIG. 2A is a schematic diagram showing image data at an arbitrary depth in the case of using a lateral filter. FIG. 2B is a schematic diagram showing the filter coefficients corresponding to the image data in FIG. 2A.

[0027] FIGs. 2A and 2B show a state where reception beams RX1, RX2, RX3, RX4, and RX5 are formed from transmission beams TX1, TX2, TX3, TX4, and TX5, respectively. In FIG. 2A, D1, D2, D3, D4, and D5 represent image data on the reception beams RX1, RX2, RX3, RX4, and RX5, respectively, at an arbitrary depth. Herein, the description is directed to the case where, for example, the lateral filter forms a single beam from the five reception beams. As shown in FIG. 2B, it is assumed that the filter coefficient for forming data at an arbitrary sampling point on the reception beam RX3 is C1. Similarly, it is assumed that the filter coefficient corresponding to the reception beam RX2 is C21, the filter coefficient corresponding to the reception beam RX4 is C22, the filter coefficient corresponding to the reception beam RX1 is C31, and the filter coefficient corresponding to the reception beam RX5 is C32. In this case, output data "Out" obtained as a result of the filtering are expressed by the following Formulas (1) and (2).

[0028]

$$\text{Out} = (D1 \times C31 + D2 \times C21 + D3 \times C1 + D4 \times C22 + D5 \times C32)$$

Formula (1)

$$C31 + C21 + C1 + C22 + C32 = 1$$

Formula (2)

[0029] In general, as shown in FIG. 2B, the filter coefficients in the filtering processing for reducing a difference in image quality between adjacent beams are set such that the filter coefficient C1 for the same position as that of the arbitrary sampling point (Out) is set to a maximum value and the other filter coefficients are set in a bilaterally symmetrical manner with respect to C1. That is to say, the filter coefficients C21, C22, C31, and C32 are expressed by the following Formula (3).

[0030]

$$C21 = C22 = C2, C31 = C32 = C3 \quad \text{Formula (3)}$$

[0031] When the filter coefficients assume positive values, the output data "Out" obtained as a result of the filtering are expressed by the following Formulas (4), (5), and (6).

[0032]

$$\text{Out} = (D1 \times C3 + D2 \times C2 + D3 \times C1 + D4 \times C2 + D5 \times C3) \quad \text{Formula (4)}$$

$$C3 + C2 + C1 + C2 + C3 = 1 \quad \text{Formula (5)}$$

$$C1 > C2 > C3 \quad \text{Formula (6)}$$

[0033] FIGs. 3A and 3B show the setting of the filter coefficients in the case where a diamond-shaped filter is used instead of a lateral filter. FIGs. 3A and 3B are a schematic diagram showing image data at an arbitrary depth, and a schematic diagram showing the filter coefficients corresponding thereto, respectively, in the case of using a diamond-shaped filter.

[0034] Also in the case of using a diamond-shaped filter, the filter coefficients are set as in the case of using a lateral filter such that a filter coefficient C1 for the same position as that of an arbitrary sampling point (Out) is set to a maximum value and the other filter coefficients are set in a bilaterally and vertically symmetrical manner with respect to the filter coefficient C1. Herein, it is assumed that data at an arbitrary sampling point on a reception beam RX3 are formed, and when the filter coefficients assume positive values, output data "Out" obtained as a result of the filtering are expressed by the following Formulas (7), (8), and (9).

[0035]

$$\begin{aligned} \text{Out} = & (D1 \times C3 + D2 \times C2 + D3 \times C1 + D4 \times C2 + D5 \times C3) \\ & + (D2a \times C4 + D3a \times C5 + D4a \times C4) \\ & + (D21 \times C4 + D31 \times C5 + D41 \times C4) \\ & + D3b \times C6 + D32 \times C6 \end{aligned} \quad \text{Formula (7)}$$

$$C1 + 2 \times C2 + 2 \times C3 + 4 \times C4 + 2 \times C5 + 2 \times C6 = 1 \quad \text{Formula (8)}$$

$$C1 > C2 > C3, C1 > C5 > C6, C5 > C4, \text{ and } C2 > C4 \quad \text{Formula (9)}$$

[0036] Next, with reference to FIGs. 4A to 4C, a description will be given of the filtering processing for reducing a

difference in image quality between adjacent beams in the case where a plurality of reception beams are formed from a single transmission beam and where, for example, a lateral filter is used for forming two reception beams. This processing is carried out on the condition characteristic of the present embodiment.

[0037] FIG. 4A is a schematic diagram showing image data at an arbitrary depth. FIGs. 4B and 4C are schematic diagrams showing the filter coefficients for forming data "OutL" at an arbitrary sampling point on a reception beam RX1L, and the filter coefficients for forming data "OutR" at an arbitrary sampling point on a reception beam RX1R, respectively, in the case of using a lateral filter.

[0038] As shown in FIGs. 4A to 4C, two reception beams RX0L and RX0R, two reception beams RX1L and RX1R, and two reception beams RX2L and RX2R are formed from a transmission beam TX0, a transmission beam TX1, and a transmission beam TX2, respectively.

[0039] In FIG. 4A, D1, D2, D3, D4, D5, and D6 represent image data on the reception beams RX0L, RX0R, RX1L, RX1R, RX2L, and RX2R, respectively, at an arbitrary depth. Since the image data D1 and D2 are obtained from the same transmission beam TX0, these data show a strong correlation with each other, and in many cases their values are closer to each other than values of D2 and D3. Such a relationship is expressed by the following Formula (10). Similarly, there is also a strong correlation between D3 and D4 and between D5 and D6.

[0040]

$$| D1 - D2 | < | D3 - D2 | \quad \text{Formula (10)}$$

[0041] It is assumed that a single beam is formed from five beams and that the filter coefficients for forming data "OutL" at an arbitrary sampling point on the reception beam RX1L are C1, C21, C22, C31, and C32 as shown in FIG. 4B. In this case, output data "OutL" obtained as a result of the filtering are expressed by the following Formulas (11) and (12).

[0042]

$$\text{OutL} = (D1 \times C31 + D2 \times C21 + D3 \times C1 + D4 \times C22 + D5 \times C32) \quad \text{Formula (11)}$$

$$C31 + C21 + C1 + C22 + C32 = 1 \quad \text{Formula (12)}$$

[0043] Note here that the filter coefficients are not set in a bilaterally symmetrical manner but are set in an asymmetrical manner so as to cancel a difference in correlation between image data obtained from a single transmission beam and image data obtained from different transmission beams as mentioned above. For example, when the filter coefficients assume positive values, they are set so as to satisfy the relationship expressed by the following Formula (13).

[0044]

$$C22 < C21 \quad \text{Formula (13)}$$

[0045] By setting the filter coefficients in this manner, the filtering processing for reducing a difference in image quality between adjacent beams is optimized. As a result, it is possible to display a high-quality ultrasonic image in which stripes are generated less in a direction in which acoustic lines are arranged.

[0046] Similarly, as shown in FIG. 4C, it is assumed that the filter coefficients for forming data "OutR" at an arbitrary sampling point on the reception beam RX1R are C1, C21, C22, C31, and C32, and when these filter coefficients assume positive values, output data "OutR" obtained as a result of the filtering are expressed by the following Formulas (14), (15), and (16).

[0047]

$$\text{OutR} = (D2 \times C32 + D3 \times C22 + D4 \times C1 + D5 \times C21 + D6 \times C31)$$

Formula (14)

5

$$C32 + C22 + C1 + C21 + C31 = 1$$

Formula (15)

10

$$C22 < C21$$

Formula (16)

15 **[0048]** FIGs. 5A, 5B, and 5C show the setting of the filter coefficients in the case where a diamond-shaped filter is used instead of a lateral filter. FIG. 5A is a schematic diagram showing image data at an arbitrary depth. FIGs. 5B and 5C are schematic diagrams showing the filter coefficients for forming data at an arbitrary sampling point on a reception beam RX1L, and the filter coefficients for forming data at an arbitrary sampling point on a reception beam RX1R, respectively.

20 **[0049]** Also in the case of using a diamond-shaped filter, the filter coefficients are set as in the case of using a lateral filter in a bilaterally and vertically asymmetrical manner with respect to an arbitrary sampling point (OutL or OutR) so as to cancel a difference in correlation between image data obtained from a single transmission beam and image data obtained from different transmission beams. For example, when the filter coefficients assume positive values, output data "OutL" and output data "OutR" obtained as a result of the filtering are expressed by the following Formulas (17), (18), (19), and (20) using the filter coefficients shown in FIGs. 5B and 5C, respectively.

25

[0050]

$$\begin{aligned} \text{OutL} = & (D1 \times C31 + D2 \times C21 + D3 \times C1 + D4 \times C22 + D5 \times C32) \\ & + (D2a \times C41 + D3a \times C5 + D4a \times C42) \\ & + (D21 \times C41 + D31 \times C5 + D41 \times C42) \\ & + D3b \times C6 + D32 \times C6 \end{aligned}$$

Formula (17)

30

35

$$\begin{aligned} \text{OutR} = & (D2 \times C32 + D3 \times C22 + D4 \times C1 + D5 \times C21 + D6 \times C31) \\ & + (D3a \times C42 + D4a \times C5 + D5a \times C41) \\ & + (D31 \times C42 + D41 \times C5 + D51 \times C41) \\ & + D4b \times C6 + D42 \times C6 \end{aligned}$$

Formula (18)

40

45

$$\begin{aligned} C1 + C21 + C22 + C31 + C32 + 2 \times C41 + 2 \times C42 + 2 \times C5 \\ + 2 \times C6 = 1 \end{aligned}$$

Formula (19)

50

$$C21 > C22 \text{ and } C41 > C42$$

Formula (20)

55 **[0051]** As described above, according to the present embodiment, the filter coefficients can be controlled optimally with respect to signals between a plurality of reception beams including ones received in parallel from a single transmission beam, in accordance with a position of each of the reception beams with respect to a transmission beam. As a result,

it becomes possible to display a high-quality ultrasonic image in which stripes are generated less in a direction in which acoustic lines are arranged and that is well defined in detail. Further, the optimization of the filter coefficients allows beam distortion to be corrected.

5 (Second Embodiment)

10 **[0052]** FIG. 6 is a functional block diagram showing an exemplary configuration of an ultrasonic diagnosis apparatus according to a second embodiment of the present invention. The present embodiment is directed to an ultrasonic diagnosis apparatus having a two-dimensional Doppler (color Doppler) function. This ultrasonic diagnosis apparatus has the same configuration as that in the first embodiment except for additional components for achieving the two-dimensional Doppler function. In the following description, the memory control portion 2 and the spatial filter operation portion 4 in FIG. 1 are referred to as a first memory control portion 2 and a first spatial filter operation portion 4, respectively.

15 **[0053]** The additional components in the present embodiment will be described below. A brightness signal processing portion 10 and a two-dimensional Doppler processing portion 11 are provided between an ultrasonic reception data processing portion 1 and a spatial filter 15. The spatial filter 15 includes the first memory control portion 2, memories 3, the first spatial filter operation portion 4, and a filter coefficient calculation portion 5 as the spatial filter 9 does in the first embodiment, and further includes two-dimensional Doppler memories 13 (second storage means), a second memory control portion 12 (second control means), and a second spatial filter operation portion 14.

20 **[0054]** Data supplied via the brightness signal processing portion 10 are subjected to the same processing as that in the first embodiment by the first memory control portion 2, the memories 3, and the first spatial filter operation portion 4, and are supplied to a scanning conversion portion 7.

25 **[0055]** The two-dimensional Doppler signal processing portion 11 subjects reception beam data from the ultrasonic reception data processing portion 1 to two-dimensional Doppler processing. The two-dimensional Doppler memories 13 store the two-dimensional Doppler data output from the two-dimensional Doppler signal processing portion 11. The second memory control portion 12 controls reading and writing of data from/in the two-dimensional Doppler memories 13. The second spatial filter operation portion 14 subjects the received two-dimensional Doppler data read by the second memory control portion 12 to filtering processing in accordance with filter coefficients from the filter coefficient calculation portion 5, and supplies the resultant output data to the scanning conversion portion 7. The filtering processing is carried out with respect to a plurality of the received two-dimensional Doppler data so as to reduce a difference in image quality between adjacent beams.

30 **[0056]** With this configuration, the ultrasonic diagnosis apparatus having the two-dimensional Doppler (color Doppler) function can control the filter coefficients optimally with respect to signals between a plurality of reception beams including ones received in parallel from a single transmission beam, in accordance with a position of each of the reception beams with respect to a transmission beam. As a result, it becomes possible to display a high-quality ultrasonic image that is well defined in detail with reduced noticeable stripes seen in two-dimensional Doppler in a direction in which acoustic lines are arranged. Further, the optimization of the filter coefficients allows beam distortion to be corrected.

(Third Embodiment)

40 **[0057]** FIG. 7 is a functional block diagram showing an exemplary configuration of an ultrasonic diagnosis apparatus according to a third embodiment of the present invention. The present embodiment is directed to an ultrasonic diagnosis apparatus having a function of controlling filter coefficients in accordance with a receiving depth. This ultrasonic diagnosis apparatus has the same configuration as that in the first embodiment except for an additional component of a depth information generation portion 17 for supplying information on the receiving depth to a filter coefficient calculation portion 16.

45 **[0058]** With this configuration, it is possible to set a different filter coefficient depending upon the depth of image data. For example, as shown in FIG. 8, in the case where a distance between acoustic lines 18 is different depending upon the depth, and accordingly a distance between image data D on adjacent acoustic lines 18 is different depending upon the depth, it is possible to reduce a difference in correlation depending upon the depth. In order to reduce such a difference in correlation, filter coefficients of stronger correlation are set for a shallow portion, and filter coefficients of weaker correlation are set for a deep portion. As a result, it is possible to display a high-quality ultrasonic image with little lateral shift.

(Fourth Embodiment)

55 **[0059]** FIG. 9 is a functional block diagram showing an exemplary configuration of an ultrasonic diagnosis apparatus according to a fourth embodiment of the present invention. The present embodiment is directed to an ultrasonic diagnosis apparatus having a function of controlling filter coefficients in accordance with an angle of a reception beam. This

ultrasonic diagnosis apparatus has the same configuration as that in the first embodiment except for an additional component of a beam angle information generation portion 20 for supplying information on the angle of a reception beam to a filter coefficient calculation portion 19.

[0060] With this configuration, it is possible to set a different filter coefficient depending upon the angle of a reception beam. For example, as shown in FIG. 10A, in the case where transmission and reception are performed with angled acoustic lines 21, filter coefficients are optimized such that, for example, filter coefficients of weak correlation are set between the same depths. As a result, it is possible to display a high-quality ultrasonic image with little lateral shift. Further, as shown in FIG. 10B, in the case where a deflection angle is different depending upon an acoustic line 22, the optimization of the filter coefficients allows beam distortion to be corrected.

(Fifth Embodiment)

[0061] FIG. 11 is a functional block diagram showing an exemplary configuration of an ultrasonic diagnosis apparatus according to a fifth embodiment of the present invention. The present embodiment is directed to an ultrasonic diagnosis apparatus having a function of controlling filter coefficients in accordance with a focal position of a transmission beam. This ultrasonic diagnosis apparatus has the same configuration as that in the first embodiment except for an additional component of a transmission beam focal position information generation portion 24 for supplying information on the focal position of a transmission beam to a filter coefficient calculation portion 23.

[0062] With this configuration, it is possible to control filter coefficients in accordance with a focal position of a transmission beam. For example, in the case where a transmission beam is focused on a position F as shown in FIG. 12, filter coefficients of weak correlation are set for the vicinity of the focal position F of the transmission beam, and filter coefficients of strong correlation are set for positions away from the focal position F of the transmission beam. By optimizing the filter coefficients in this manner, it is possible to display a high-quality ultrasonic image that is uniform regardless of the focal position of the transmission beam.

Industrial Applicability

[0063] The ultrasonic diagnosis apparatus according to the present invention is useful for displaying a high-quality ultrasonic image that is well defined in detail with reduced noticeable stripes seen in two-dimensional Doppler in a direction in which acoustic lines are arranged, with respect to signals between a plurality of reception beams obtained from a single transmission beam.

Claims

1. An ultrasonic diagnosis apparatus, comprising:

first storage means for storing digital reception beam data converted from a reception beam formed from an ultrasonic received signal;

first control means for controlling reading and writing of data from/in the first storage means;

a filter coefficient calculation portion for calculating a filter coefficient based on information on the reception beam, the information including a positional relationship between the reception beam and a transmission beam; and

a first spatial filter operation portion for subjecting each of a plurality of the reception beam data including data of beams received in parallel from a single transmission beam to filtering processing for reducing a difference in image quality between adjacent beams based on the filter coefficient, wherein image data output from the first spatial filter operation portion are converted into scanning of a display monitor so as to display an image on the display monitor.

2. The ultrasonic diagnosis apparatus according to claim 1, further comprising:

a two-dimensional Doppler signal processing portion for subjecting reception beam data from an ultrasonic reception data processing portion to two-dimensional Doppler processing;

second storage means for storing two-dimensional Doppler data output from the two-dimensional Doppler signal processing portion;

second control means for controlling reading and writing of data from/in the second storage means; and

a second spatial filter operation portion for subjecting each of a plurality of the received two-dimensional Doppler data including data of beams received in parallel from a single transmission beam to filtering processing for

EP 1 709 908 A1

reducing a difference in image quality between adjacent beams based on the filter coefficient supplied from the filter coefficient calculation portion.

- 5
3. The ultrasonic diagnosis apparatus according to claim 1 or 2, wherein the filter coefficient calculation portion is able to control the filter coefficient in accordance with a receiving depth.
 4. The ultrasonic diagnosis apparatus according to claim 1 or 2, wherein the filter coefficient calculation portion is able to control the filter coefficient in accordance with an angle of the reception beam.
 - 10 5. The ultrasonic diagnosis apparatus according to claim 1 or 2, wherein the filter coefficient calculation portion is able to control the filter coefficient in accordance with a focal position of the transmission beam.

15

20

25

30

35

40

45

50

55

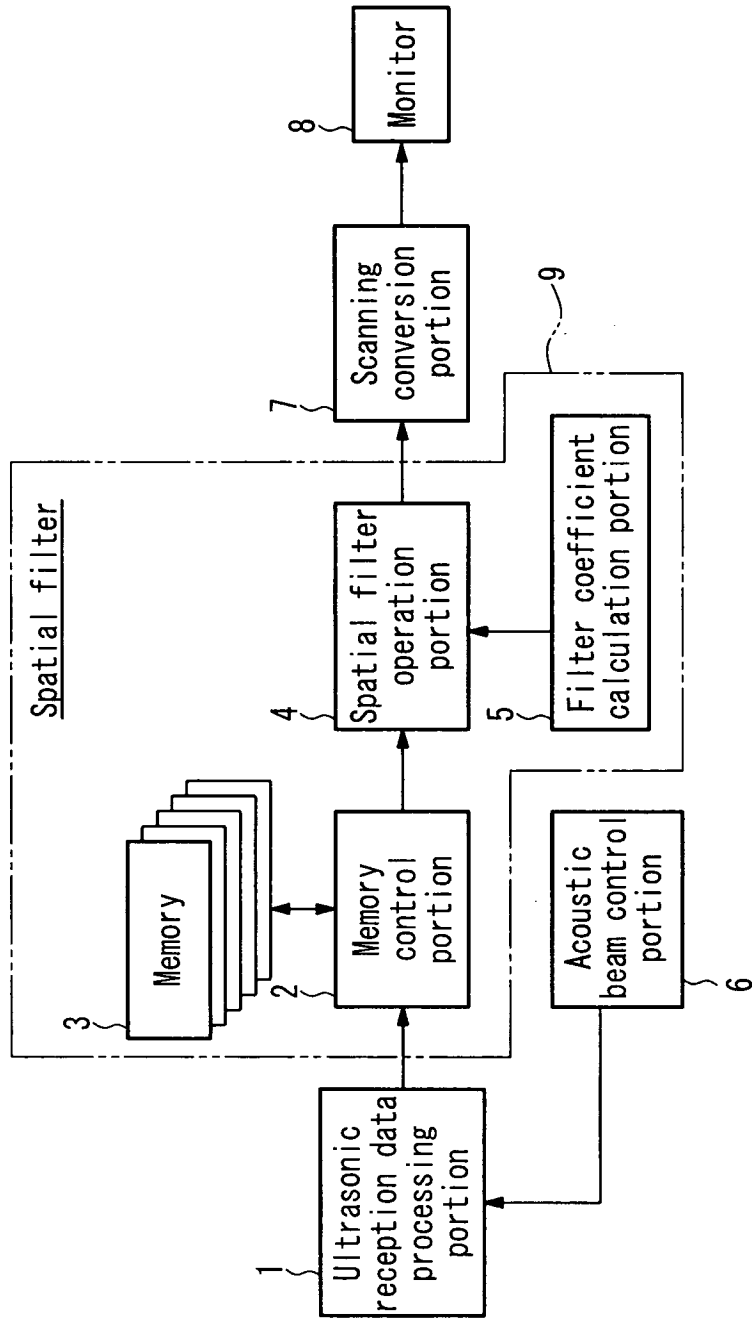

FIG. 1

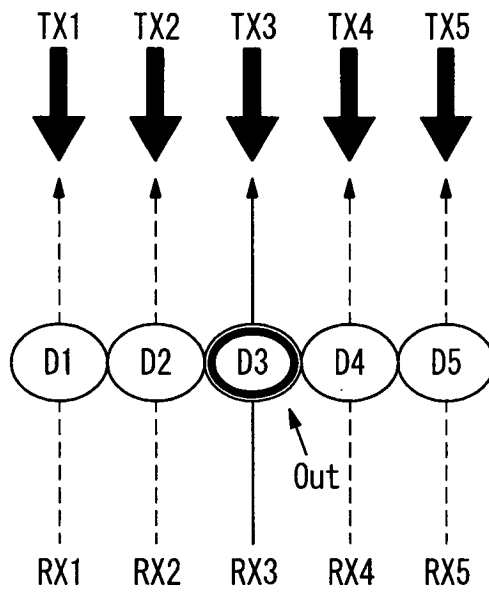

FIG. 2A

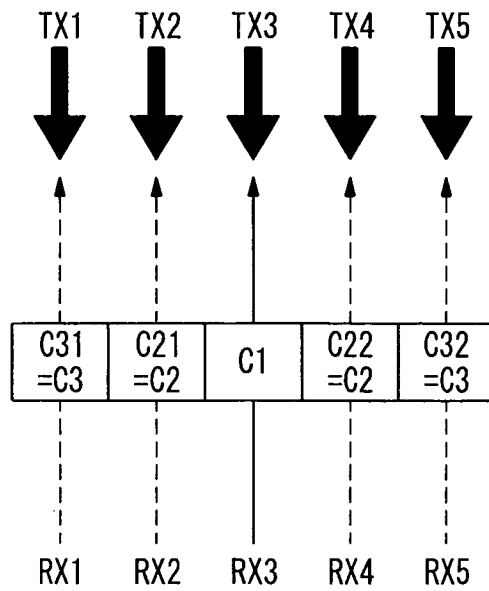

FIG. 2B

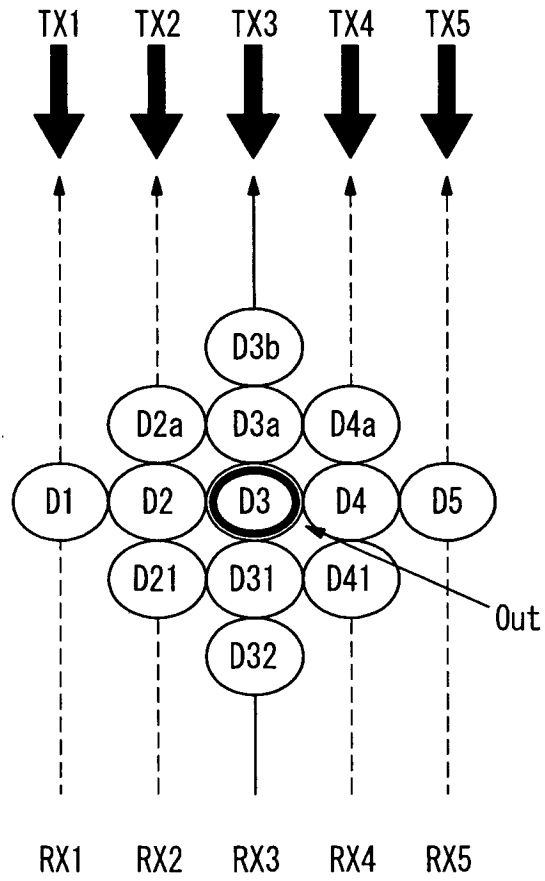

FIG. 3A

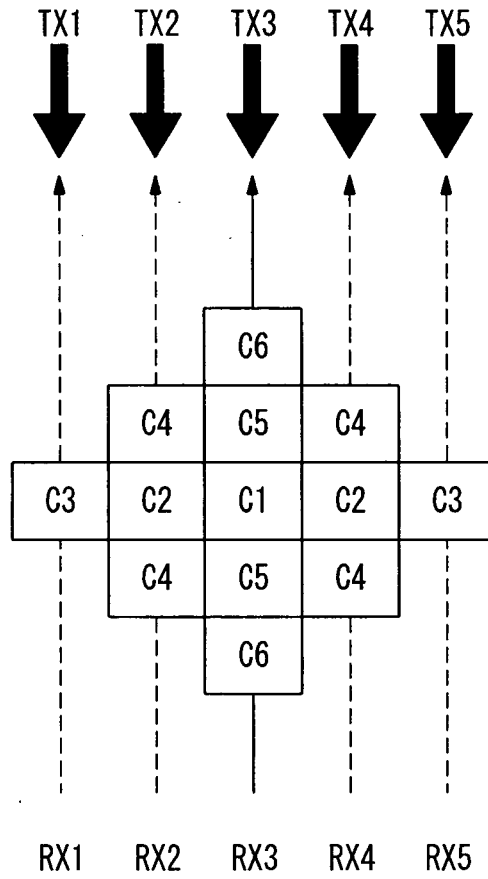

FIG. 3B

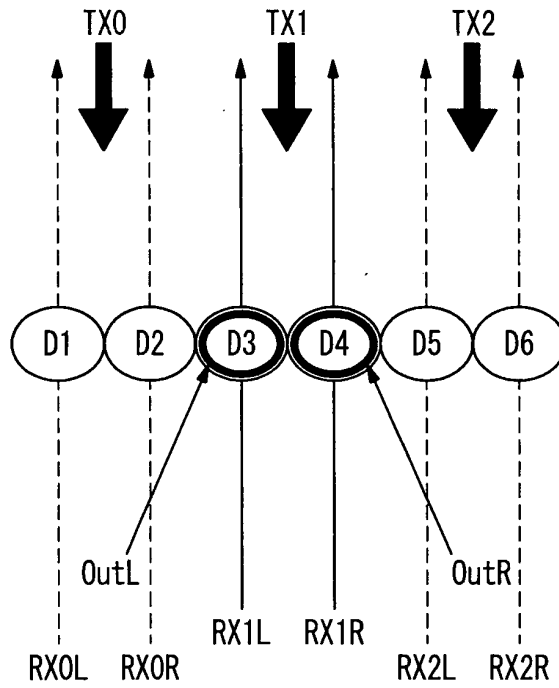

FIG. 4A

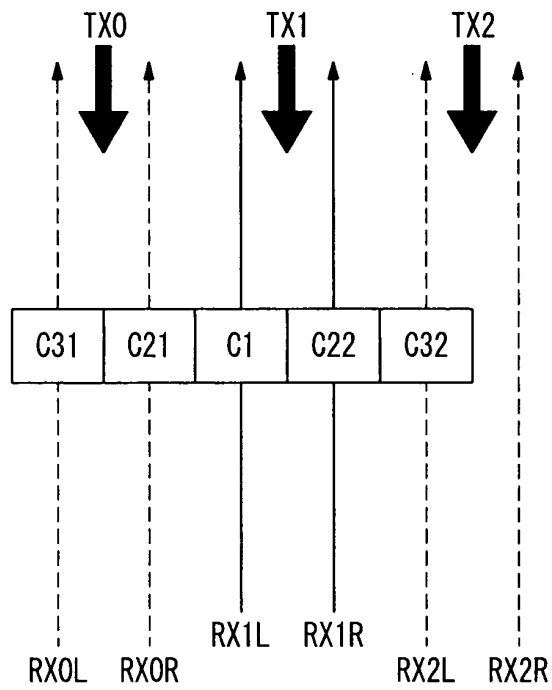

FIG. 4B

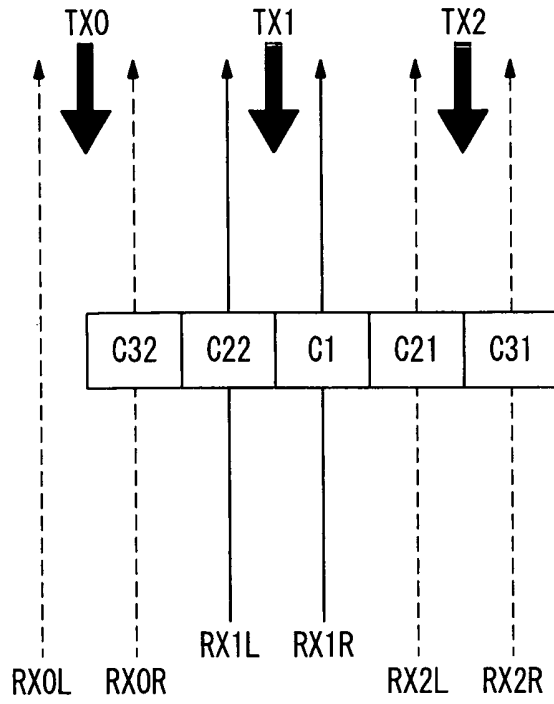

FIG. 4C

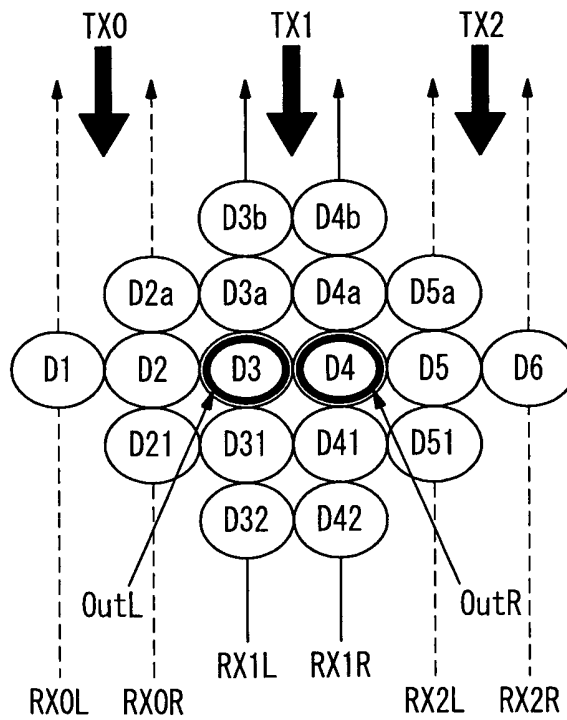

FIG. 5A

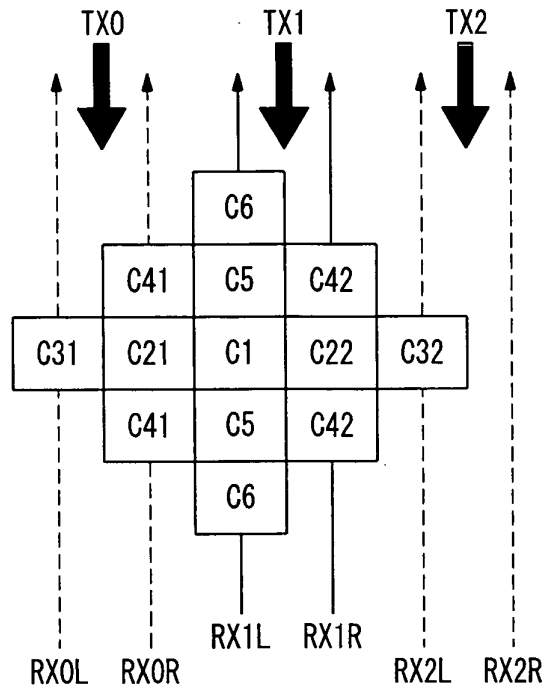

FIG. 5B

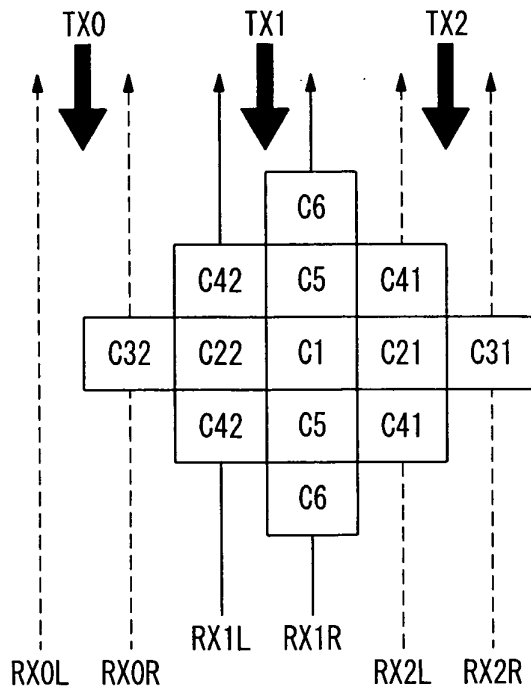

FIG. 5C

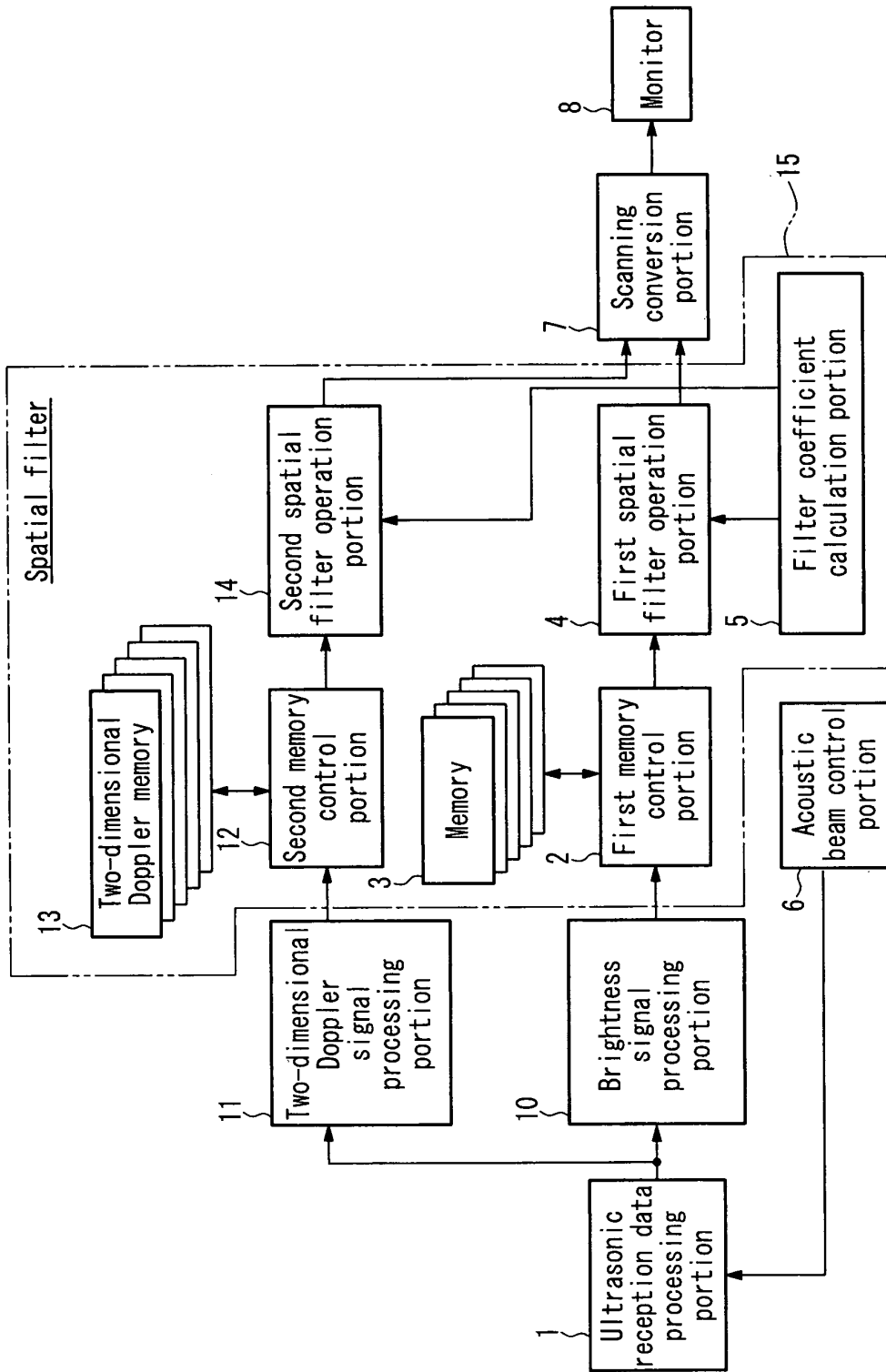

FIG. 6

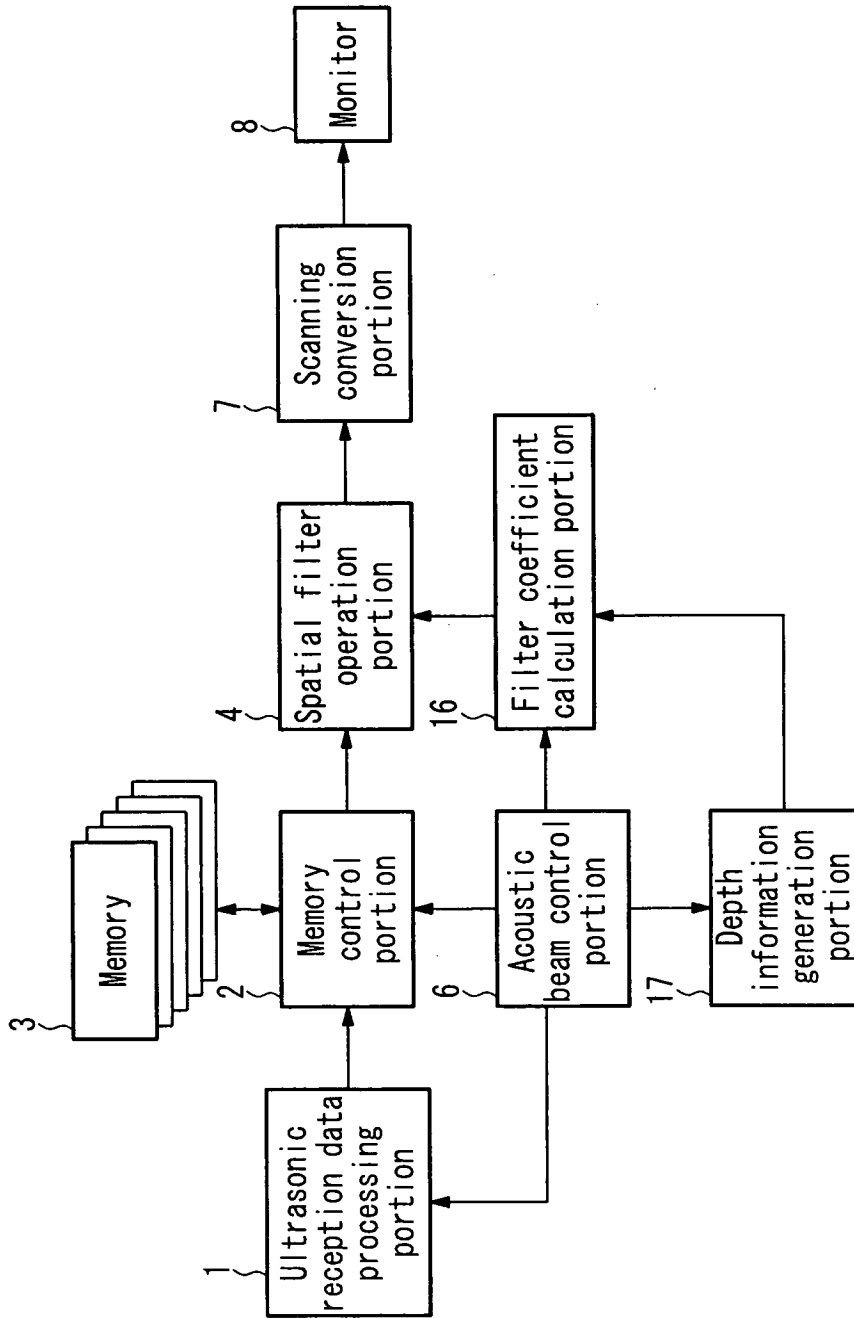

FIG. 7

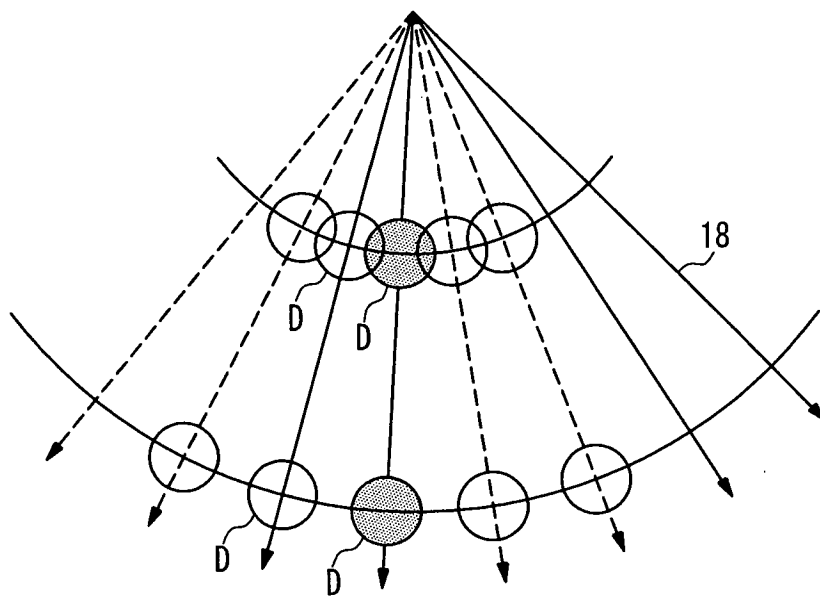

FIG. 8

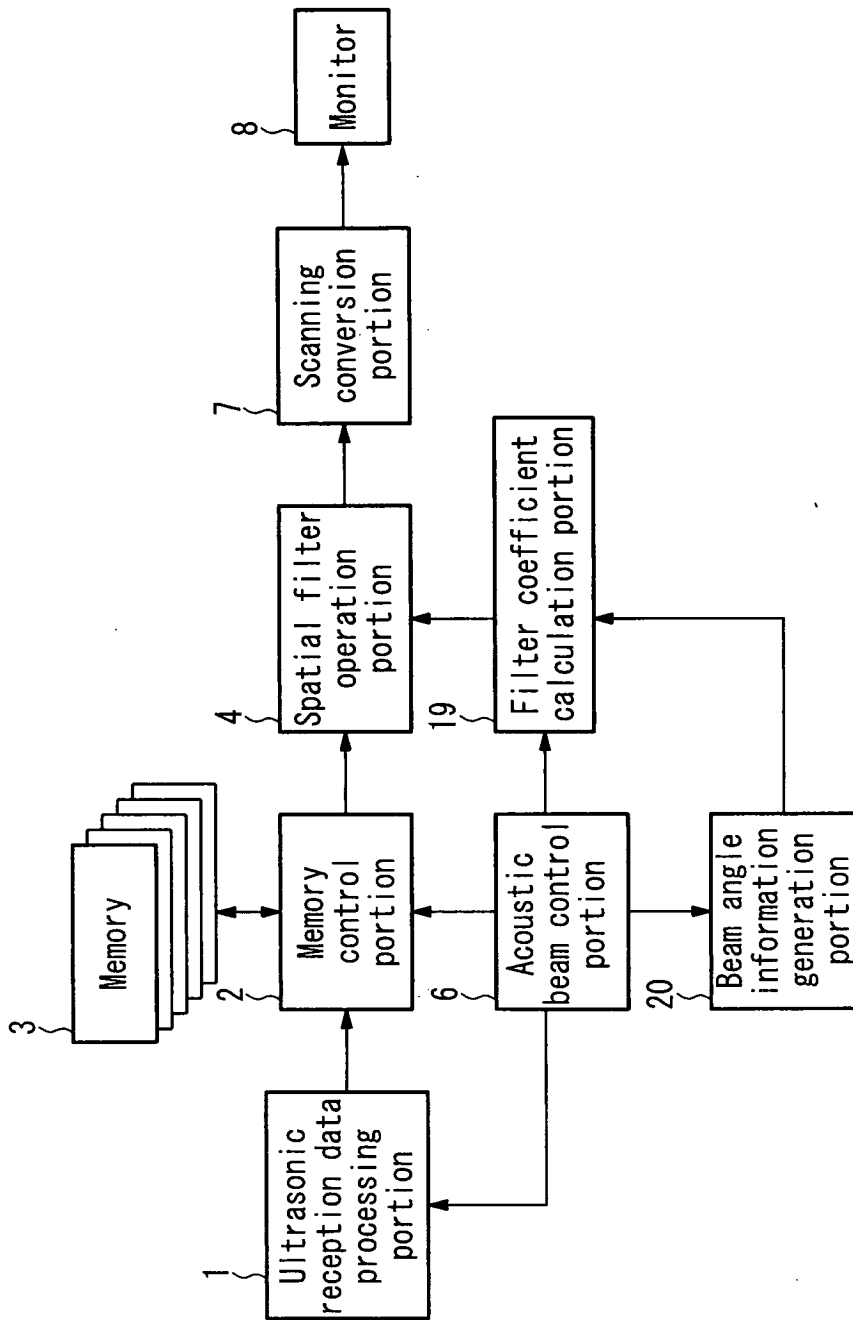

FIG. 9

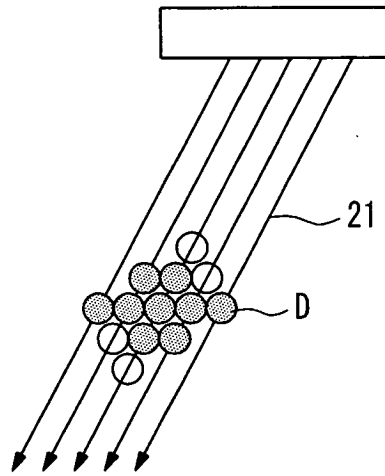

FIG. 10A

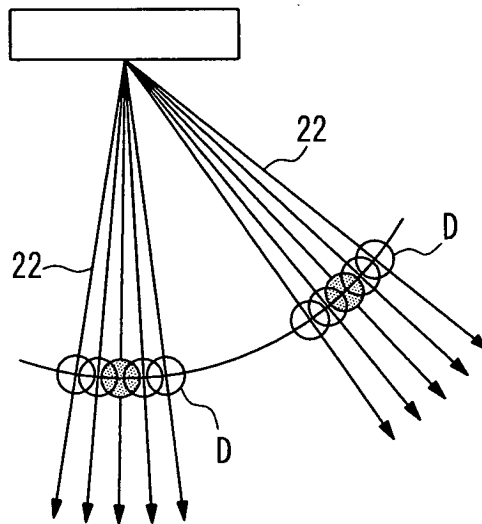

FIG. 10B

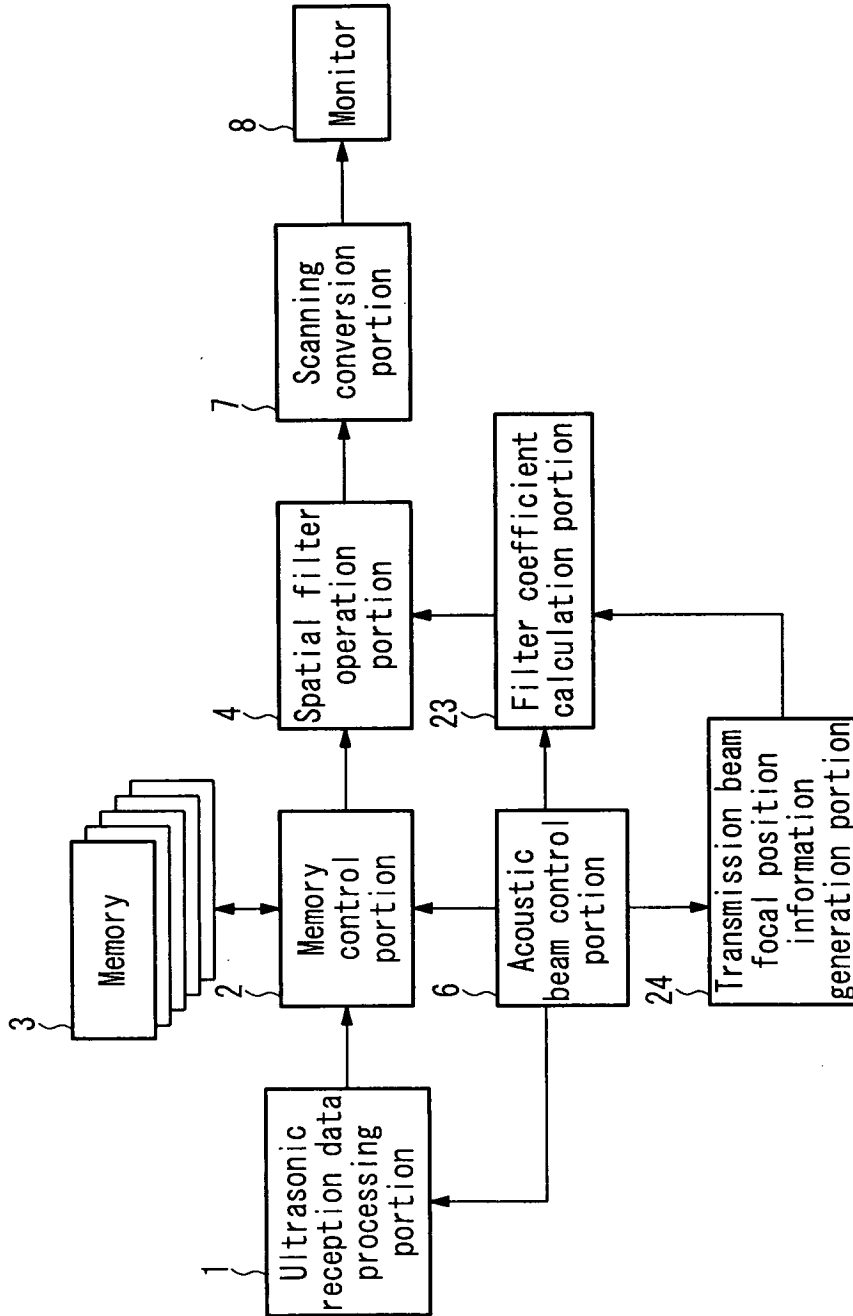

FIG. 11

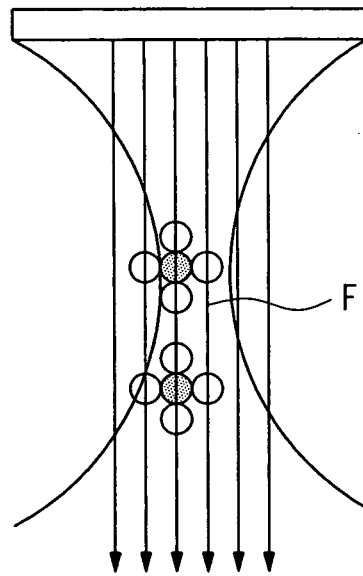

FIG. 12

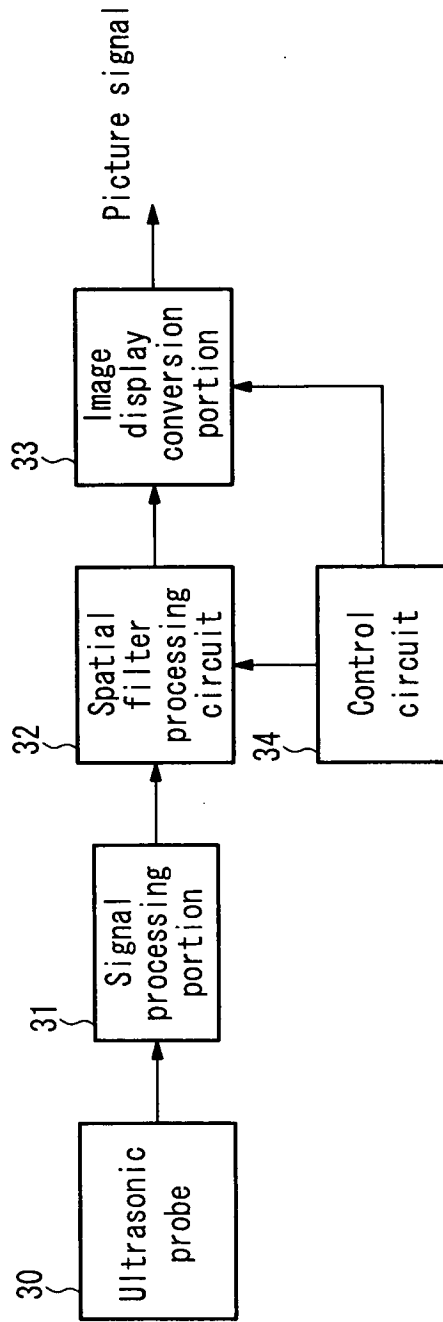

FIG. 13

INTERNATIONAL SEARCH REPORT

International application No.

PCT/JP2005/000074

A. CLASSIFICATION OF SUBJECT MATTER Int.Cl. ⁷ A61B8/00		
According to International Patent Classification (IPC) or to both national classification and IPC		
B. FIELDS SEARCHED		
Minimum documentation searched (classification system followed by classification symbols) Int.Cl. ⁷ A61B8/00-8/15		
Documentation searched other than minimum documentation to the extent that such documents are included in the fields searched Jitsuyo Shinan Koho 1922-1996 Toroku Jitsuyo Shinan Koho 1994-2005 Kokai Jitsuyo Shinan Koho 1971-2005 Jitsuyo Shinan Toroku Koho 1996-2005		
Electronic data base consulted during the international search (name of data base and, where practicable, search terms used)		
C. DOCUMENTS CONSIDERED TO BE RELEVANT		
Category*	Citation of document, with indication, where appropriate, of the relevant passages	Relevant to claim No.
X Y	JP 6-14929 A (Hewlett-Packard Co.), 25 January, 1994 (25.01.94), Full text; all drawings & US 5318033 A	1, 4, 5 2, 3
Y A	JP 10-118063 A (Aloka Co., Ltd.), 12 May, 1998 (12.05.98), Full text; all drawings (Family: none)	2 1, 3-5
Y	JP 2001-340338 A (Olympus Optical Co., Ltd.), 11 December, 2001 (11.12.01), Full text; all drawings (Family: none)	3
<input checked="" type="checkbox"/> Further documents are listed in the continuation of Box C. <input type="checkbox"/> See patent family annex.		
* Special categories of cited documents: "A" document defining the general state of the art which is not considered to be of particular relevance "E" earlier application or patent but published on or after the international filing date "L" document which may throw doubts on priority claim(s) or which is cited to establish the publication date of another citation or other special reason (as specified) "O" document referring to an oral disclosure, use, exhibition or other means "P" document published prior to the international filing date but later than the priority date claimed "T" later document published after the international filing date or priority date and not in conflict with the application but cited to understand the principle or theory underlying the invention "X" document of particular relevance; the claimed invention cannot be considered novel or cannot be considered to involve an inventive step when the document is taken alone "Y" document of particular relevance; the claimed invention cannot be considered to involve an inventive step when the document is combined with one or more other such documents, such combination being obvious to a person skilled in the art "&" document member of the same patent family		
Date of the actual completion of the international search 25 January, 2005 (25.01.05)		Date of mailing of the international search report 08 February, 2005 (08.02.05)
Name and mailing address of the ISA/ Japanese Patent Office		Authorized officer
Facsimile No.		Telephone No.

Form PCT/ISA/210 (second sheet) (January 2004)

INTERNATIONAL SEARCH REPORT

International application No.

PCT/JP2005/000074

C (Continuation). DOCUMENTS CONSIDERED TO BE RELEVANT

Category*	Citation of document, with indication, where appropriate, of the relevant passages	Relevant to claim No.
A	JP 7-8492 A (Toshiba Corp., Toshiba Medical Engineering Kabushiki Kaisha), 13 January, 1995 (13.01.95), Full text; all drawings (Family: none)	1-5
A	JP 10-328185 A (Aloka Co., Ltd.), 15 December, 1998 (15.12.98), Full text; all drawings (Family: none)	1-5

Form PCT/ISA/210 (continuation of second sheet) (January 2004)

REFERENCES CITED IN THE DESCRIPTION

This list of references cited by the applicant is for the reader's convenience only. It does not form part of the European patent document. Even though great care has been taken in compiling the references, errors or omissions cannot be excluded and the EPO disclaims all liability in this regard.

Patent documents cited in the description

- JP 2001340338 A [0002]

专利名称(译)	超声诊断仪		
公开(公告)号	EP1709908A1	公开(公告)日	2006-10-11
申请号	EP2005703342	申请日	2005-01-06
申请(专利权)人(译)	松下电器产业有限公司.		
当前申请(专利权)人(译)	柯尼卡美能达, INC.		
[标]发明人	UCHIKAWA AKIKO C O MATSUSHITA ELECT IND CO LTD ITO YOSHIHIKO C O MATSUSHITA ELECT IND CO LTD NAKAMURA YASUHIRO C O MATSUSHITA ELECT IND CO LTD		
发明人	UCHIKAWA, AKIKO C/O MATSUSHITA ELECT.IND.CO. LTD. ITO, YOSHIHIKO C/O MATSUSHITA ELECT.IND.CO. LTD. NAKAMURA, YASUHIRO C/O MATSUSHITA ELECT.IND.CO.LTD		
IPC分类号	A61B8/00 G01S7/52 G06T5/00		
CPC分类号	A61B8/00 G01S7/52026 G01S7/52077 G01S7/52085 G01S7/52095 G01S15/8979		
优先权	2004003310 2004-01-08 JP		
其他公开文献	EP1709908A4		
外部链接	Espacenet		

摘要(译)

提供了第一存储装置 (3) , 用于存储从由超声波接收信号形成的接收波束转换的数字接收波束数据;第一控制装置 (2) , 用于控制从第一存储装置读取数据和在第一存储装置中写入数据;滤波器系数计算部分 (5) , 用于根据接收波束的信息计算滤波器系数, 该信息包括接收波束和发送波束之间的位置关系;第一空间滤波器操作部分 (4) , 用于对包括从单个发送波束并行接收的波束数据的多个接收波束数据中的每一个进行滤波处理, 以基于滤波器减小相邻波束之间的图像质量差异系数。从第一空间滤波器操作部分输出的图像数据被转换成显示监视器 (8) 的扫描, 以便在显示监视器上显示图像。在具有并行接收功能的超声波诊断装置中, 可以显示高质量的超声波图像, 其中在布置声线的方向上产生的条纹较少并且在细节上很好地定义。

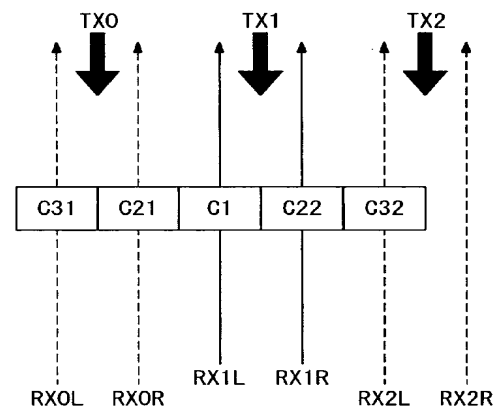

FIG. 4B