



(12) **EUROPEAN PATENT SPECIFICATION**

(45) Date of publication and mention
of the grant of the patent:

19.05.2004 Bulletin 2004/21

(21) Application number: **01974506.6**

(22) Date of filing: **11.10.2001**

(51) Int Cl.⁷: **A61B 8/12**

(86) International application number:
PCT/GB2001/004548

(87) International publication number:
WO 2002/032315 (25.04.2002 Gazette 2002/17)

(54) **INTRAVASCULAR ULTRASONIC CATHETER**

INTRAVASKULÄRER ULTRASCHALLKATHETER

SYSTEMES DE CATHETERS ULTRASONORES INTRAVASCULAIRES

(84) Designated Contracting States:
**AT BE CH CY DE DK ES FI FR GB GR IE IT LI LU
MC NL PT SE TR**

(30) Priority: **14.10.2000 GB 0025250**

(43) Date of publication of application:
09.07.2003 Bulletin 2003/28

(73) Proprietor: **Jomed Imaging Limited**
Isleworth, Middlesex TW7 5QD (GB)

(72) Inventors:
• **DICKINSON, Robert**
London SW18 1LE (GB)

• **NIX, Elvin**
Putney, London SW15 2QA (GB)

(74) Representative:
Prins, Adrianus Willem, Mr. Ir. et al
Vereenigde,
Nieuwe Parklaan 97
2587 BN Den Haag (NL)

(56) References cited:
EP-A- 0 671 221 **US-A- 5 060 651**
US-A- 5 345 139 **US-A- 5 947 905**

Description

[0001] The present invention relates to intravascular ultrasonic catheter arrangements and more particularly to the construction and manufacture of an ultrasonic transducer array for mounting at or near the distal end of a catheter arrangement.

[0002] Examples of the types of intravascular ultrasonic catheter arrangements to which the present invention may be applied are disclosed in our earlier United Kingdom Patent Nos. 2,221,267; 2,233,094 and our United States Patent Nos. 5,081,993; 5,257,629 and 5,456,259.

[0003] With the kinds of ultrasonic transducer array to which the present invention relates, its very small size (typically one millimetre in diameter) means that there are considerable technological problems to overcome in order to firstly make it possible to manufacture the array at an acceptable yield level and secondly to provide the array and its associated control circuitry/software with an acceptable performance particularly as far as the definition of images obtained is concerned.

[0004] Ultrasound arrays to which the present invention is applicable have typically employed piezoelectric materials such as modified PZT (lead zirconate titanate) for the transduction of a radio frequency (rf) electrical signal into an ultrasonic signal. In very high frequency applications, such as are relevant to the present invention, the performance of such piezoelectric arrays is limited by the grain size of the piezoelectric ceramic material. This is because, due to the very small size of the array, the grain size of the material begins to become comparable with the dimensions of the array elements.

[0005] Furthermore, because of the crystalline nature of the material from which the elements of the array are manufactured, the manufacturing operations such as lapping, polishing, dicing and electroding (ie securing electrodes to the elements of the array) introduce defects which are associated both with the bulk body of the transducer element material and its surface. In particular microcracks are generated which significantly reduce the macroscopic fracture resistance of the material.

[0006] One object of the present invention therefore is to overcome or reduce the above mentioned manufacturing problems whilst at the same time not prejudicing the operational performance of the ultrasonic transducer arrangement.

[0007] In order to try and overcome the above discussed problems the inventors have therefore researched alternative materials for the manufacture of ultrasonic transducer elements and have concluded that a class of materials that would be suitable are those known as electrostrictive materials such as "relaxor ferroelectrics".

[0008] It has been found that these can exhibit a large pseudo-piezoelectric response if a suitable d.c. electric bias field is applied to them. These materials have a finer

microstructure than the known PZT material discussed earlier together with enhanced fracture toughness. An example of a relaxor ferroelectric material is modified PMN (lead magnesium niobate).

[0009] As indicated these relaxor ferroelectrics can exhibit a very large pseudo piezoelectric response, typically $d_{33} \sim 3,000 \text{pC/N}$. In addition such materials are available with high values of permittivity (eg $\epsilon_r \sim 12,000$), with small grain size (eg 1-2 μm) and with improved fracture toughness.

[0010] High values of permittivity will, in general, allow improved ultra-small array elements from the interrogating electronics by reducing the element impedance.

[0011] Fine grain microstructures will reduce surface microcrack dimensions and thus the overall tendency to fracture. A further advantageous feature of an electrostrictive material is that it is unpolarised in the absence of the bias field. This means that processing steps involving heat and high local stresses will not result in the polarising degradation which can occur with piezoelectric materials such as PZT.

[0012] According to the present invention apparatus for intravascular ultrasonic imaging, the apparatus comprises a catheter having an ultrasonic transducer array fabricated at least in part from non-polymeric electrostrictive material and a high permittivity ceramic member or layer that couples a common radiofrequency source to elements of the array.

[0013] With this arrangement it is thus possible to apply the rf signals simultaneously (but not continuously) to all elements of the array because only those transducer elements which have the bias field applied to them will transform the rf signal into the correct ultrasonic signal. The drive and interrogation of the array is thus by means of the multiplexed bias voltage which opens "windows" during which the rf signal can be effective. The rf signal is turned off during the receive interval for a given channel in the usual manner.

[0014] The advantage of coupling the rf signal in this way are (i) the signal losses in the multiplexer are now only seen during the receive mode and (ii) the rf signal size is not limited by the multiplexer.

[0015] So far the present invention has been discussed in relation to the material from which the transducer elements are manufactured and this aspect of the invention is applicable irrespective of other steps in the manufacture of the ultrasonic transducer arrangement.

[0016] There will now be discussed a further aspect of the present invention which relates to the manufacturing process employed for producing an ultrasonic transducer array of the kind previously outlined, this further aspect being independent of the material employed for the manufacture of the transducer array elements.

[0017] One method of manufacturing an annular transducer array of the kind to which the present invention relates is disclosed in our European Patent No 0 671 221 in which the transducer array, and its associated multiplexer/control circuitry, is manufactured in-the-

flat initially and then transformed into a cylindrical configuration.

[0018] In such a manufacturing method the functionally independent elements of the eventual annular array are produced by the following method.

[0019] A single block of PZT is mounted on a substrate in-the-flat. A plurality of saw cuts are then made in the PZT block to define the individual transducer elements of which there are typically sixty-four. The arrangement thus produced is then folded into the final cylindrical configuration to thus produce an annular ultrasonic transducer array made up of the plurality of transducer elements. In order to facilitate folding step, the aforementioned saw cuts are continued down to some extent into the polyimide substrate on which the transducer material is mounted. This extent is critical because it has to be sufficient to allow the assembly to be folded easily whilst at the same time not weakening the substrate to the point where it will fracture.

[0020] Because of the extremely small size of the arrangement just described the sawing step in the manufacturing process has to be carried out to extremely small tolerances. In addition, for the best operating characteristics, the saw cuts should have flat-bottoms but this is difficult to achieve in practice. The bottom of the saw cut is hereinafter referred to as the "slot bottom".

[0021] Therefore, according to a further aspect of the present invention in a manufacturing process for producing an ultrasonic transducer array in which a block of transducer material is divided into a plurality of discrete transducer elements and is mounted on a flexible substrate, flexing slots are formed in the substrate between adjacent transducer elements by means of a laser beam,

[0022] This enables the depth of the cut to be more easily controlled, when compared with using a saw, and it also makes it possible to more easily approach the ideal rectangular shape for the bottom of the slot, or "slot bottom".

[0023] How the invention may be carried out will now be described by way of example only with reference to the accompanying drawings in which:

Figure 1 is a perspective view of the ultrasonic transducer/multiplexer assembly in-the-flat as shown in *Figure 4* of the applicant's European Patent No 0 671 221;

Figure 2 is a perspective view of the assembly of *Figure 1* in its final cylindrical configuration as shown in *Figure 8* of the applicant's European Patent No 0 671 221;

Figure 3 is a fragmentary perspective view to an enlarged scale of one embodiment of the present invention showing part of a transducer array and associated multiplexer arrangement in the flat condition prior to its wrapping into the its cylindrical configuration;

Figure 4 illustrates the basic electronic address cir-

cuit employed with the present invention; and *Figures 5 to 10* illustrate the various stages, according to the present invention, for forming the slot bottoms in the ultrasonic transducer.

Figures 1 and 2

[0024] A transducer array **110** and multiplexer **111** arrangement is first manufactured in-the-flat as shown in *Figure 1*. It is then wrapped or rolled into the cylindrical configuration shown in *Figure 2*.

[0025] The transducer array **110** comprises sixty four transducer elements **112** which are electrically connected to four 16-channels multiplexer chips **111a**, **111b**, **111c** and **111d** (**111b** being omitted for clarity and **111c** being only partially shown) each chip being in the form of an integrated circuit.

[0026] The advantage of initially manufacturing the assembly shown in *Figure 1* in-the-flat is that it is easier to manufacture because firstly forming the various components in-the-flat rather than on a cylindrical surface is inherently easier and secondly it is possible to use standard production equipment. More particularly standard printed circuit and integrated circuit production methods can be employed. A further advantage, is that the thickness of flat material is easier to control to high accuracy than the wall thickness of cylindrical components.

[0027] The transducer array **110** consist of functionally discrete ceramic elements mounted on a flexible substrate **113**.

[0028] Each multiplexer **111a**, **111b**, **111c** and **111d**, is in the form of an integrated circuit and this integrated circuit can itself be flip-chip bonded to a circuit comprising electrical connections **114** which are formed on the substrate **113** by means of known printed circuit techniques.

[0029] The transducer array **110** which consists of functionally discrete ceramic elements, is manufactured using the following steps.

[0030] The polyimide substrate material **113** is plated on both sides, with a 1-2 micron thickness of copper, typically by a two stage process in which vacuum deposition or sputtering is used to give a thin base coat of good allocation, and chemical plating techniques to increase the copper thickness to the desired value.

[0031] The conductive tracks **114** are then formed in the layer of copper on one side of the substrate by a standard photolithography technique followed by chemical etching or ion-beam milling to form the circuit pattern.

[0032] A block of piezo-electric material **112** having the desired radial thickness of the final transducer elements and coated on both sides by a metallisation layer, is bonded in one piece to an area of the copper layer which is shaped to define a connection pad on the substrate. The bonding is effected by a suitable adhesive which could comprise a low viscosity epoxy resin.

[0033] The polyimide substrate **113** has a copper layer on its bottom surface.

[0034] The piezo-electric transducer array, in use, would be energised through the copper layer, the upper metalised layer on the top of the piezoelectric ceramic transducer block **112** forming an earth return path and being electrically connected to the other copper layer to thus form a common return path.

[0035] The substrate **113** is provided with slots **115** to facilitate the folding or wrapping of the substrate into a cylindrical configuration as shown in *Figure 2*.

[0036] In *Figure 2* the same reference numerals have been used as in *Figure 1* in order to designate the same items.

[0037] The cylindrical transducer array and multiplexer arrangement is mounted on a flexible plastic tubular body member **201** which itself is mounted on the main flexible plastic tubular body of the catheter (not shown). The usual guide wire is shown at **202**.

Figures 3 and 4

[0038] The transducer array and associated multiplexers are substantially the same in the present invention as those disclosed in our published European Patent No 0 671 221 and illustrated in *Figures 1* and *2*, except in the following respects.

[0039] The transducer array **310** itself is fabricated from a PMN (lead magnesium niobate) and the polyimide substrate **313** carries a block **316** of high permittivity low loss ceramic associated with each of the four multiplexers **311** (only **311b** is shown). Each block **316** functions as a common rf connection between the associated multiplexer **311a, b, c** and **d** and the associated group of sixteen transducer elements for coupling the rf signal to the transducer array input tracks **314**. In a modification each ceramic block could be divided into sixteen physically articulated sections, one for each channel associated with each of the sixteen transducer elements. The block **316** capacitatively couples the multiplexer **311b** to the individual channels of the array **310** by means of a high permittivity ceramic layer.

[0040] The transducer array **310** may be made from an electrostrictive or equivalent ferroelectric relaxor material.

[0041] The multiplexer arrangement **311** is configured to transmit a DC bias voltage to the array **310**.

[0042] *Figure 3* illustrates a single quadrant of the IVUS catheter and one method of coupling the rf signal to the array. This method is directly applicable to the existing configuration of the "wrap". The principle of operation is as follows. PMN requires a bias field to become significantly piezoelectric and thus the PMN elements only transmit and receive when the bias voltage is applied through the multiplexer **311**. The rf signals can therefore be applied simultaneously (but not continuously) to all elements of the array **310**; because only those transducer elements which have the bias field ap-

plied to them will transform the rf signal into an ultrasonic signal. The drive and interrogation of the array **310** is thus by means of the multiplexed bias voltage which opens windows during which the rf signal can be effective. Clearly the rf signal but not the dc bias is turned off during the receive interval for a given channel. Advantages of coupling the rf signal in this way are (i) the signal losses in the multiplexer **311** are now only seen in receive and (ii) the rf signal size is not limited by the multiplexer **311**. *Figure 4* shows the essentials of the electronic addressing of two channels of the array.

[0043] *Figure 4* illustrates part of the control circuit for two of the transducer elements **410a** and **410b**.

[0044] The multiplexer **411** is configured to transmit a DC bias voltage **417** to the elements of the array **410**.

[0045] The high permittivity ceramic block **416** functions as a common rf connection between the multiplexer **411** and the array **410** and capacitatively couples the latter to the former. U PZT can act as such a component.

Figures 5 to 10

[0046] Existing array-dicing processes have problems with height-control and the shape of the slot bottom. The height-control problem is exacerbated by:

- (i) the non-uniformity of the polyimide substrate;
- (ii) the difficulties of vacuum-mounting an undulating, flexible substrate containing rigid components with stressed adhesive interfaces; and
- (iii) dicing-blade wear. The slot bottom problem relates primarily to the rounded shape of the cutting edge of the dicing blade which is reproduced approximately in the array slot-bottom.

[0047] Flat-bottomed blades are difficult to achieve in practice because both the blade-dressing procedure prior to dicing and the blade-wear of the dicing process itself tend to yield a rounded blade-edged profile. The rounded profile, leading to a similar shape in the polyimide slot bottom, is undesirable from the point of view of the wrap-mechanics and acoustic performance of the final array. Furthermore, any subsequent processing of a saw-cut polyimide slot bottom (e.g. by laser ablation) would necessarily begin from the "parabolic" shape left by the sawing process, and may not result in the desired rectangular shape. The process issues to be addressed are therefore:

- (i) how can shape-controlled slots be cut into a thin, flexible and variable carrier film?
- (ii) can a pre-cut flex-circuit slot bottom, be ablated accurately using the flex-circuit itself as a mask?

[0048] The present invention relates to the fabrication of rectangular slot bottoms in the polyimide substrate by a laser ablation process prior to array dicing. The flex-circuit slot bottom is ablated using the flex-circuit itself

as a mask, which automatically aligns the slot bottoms with the flex-circuit.

[0049] The following process achieves a rectangular slot bottom in the polyimide.

[0050] The flex-circuit is utilised as a mask for laser ablation. The transducer area of the flex-circuit contains copper tracks **51** of width equal to the element width, namely 30 μm formed in a polyimide matching layer **50**. These tracks **51** in conjunction with a rectangular aperture step **52**, defining an overall exposure window, are used as a mask for laser ablation of rectangular trenches **53** of width $\sim 17 \mu\text{m}$ in the polyamide flex-circuit. The intensity-time exposure parameters for the laser yield reproducible slot bottoms **54**. It may be advantageous to thicken the tracks **51** to 1-2 μm by use of nickel plating in the transducer area, as on the remainder of the flex-circuit.

[0051] The whole flex-circuit **51** is coated with a layer of photoresist **55** $\sim 5 \mu\text{m}$ thick using a spinning technique, giving the result illustrated in *Figure 7*. It is only necessary that the trenches **53** be partly filled with the photoresist material **55**.

[0052] The photoresist layer **55** is ablated and the $\sim 5 \mu\text{m}$ thick layer **55a** covering the metal tracks **51** is removed. This will leave a photoresist layer **55b** in the trench-bottoms, as illustrated in *Figure 8*. The same result can also be achieved by "wicking" photoresist (or an alternative slot bottom fill substance) along the trenches (i.e. relying on capillary action to cause the resist to move along the trenches to substantially fill them) from one end, or by selective ultra violet curing of the photoresist layer means of an auxiliary mask.

[0053] Having accurately formed the slot bottom **54** using a laser (*Figures 5 to 8*), the PZT transducer array is then fabricated on top of the arrangement shown in *Figure 8*. This fabrication is illustrated in *Figures 9 and 10*.

[0054] A PZT block **91** is bonded by adhesive **92** to the layer **50** using known adhesive techniques. This is illustrated in *Figure 9*. The adhesive **92** will fill the trenches **54** above the photoresist layer **55b** and will not penetrate to the bottom of the slot bottom **91a**, **91b**, **91c**, **91d** etc. There is an upper metallisation layer **93** topped by a polyimide ground plane **94**.

[0055] The individual PZT elements of the transducer array are diced in the normal way using a diamond saw to create the slots, ensuring the blade penetrates the polyimide by approximately two thirds of its kerf depth (e.g. 10 μm if the polyimide kerf is 15 μm deep). This is illustrated in *Figure 10*, and shows the saw cuts penetrating into the temporary key-fill material (photoresist) **55b**, the saw being indicated at **101** in broken lines.

[0056] The polyimide slot bottoms are cleaned with a suitable solvent to remove the residual photoresist **55b** and create an empty flat bottomed slot bottom.

[0057] The advantages of the modified process are the following:

(i) A reproducible slot bottom can be created in the polyimide without melting or tearing of the plastic and without the risk of depth overshoot inherent in the existing sawing process. That is, the laser will ablate a certain thickness of polyimide irrespective of whether or not the flex-circuit is flat, whereas the sawing process depends critically on mounting-fixture flatness, flex circuit planarity and flex-circuit thickness variability.

(ii) A rectangular slot bottom is the optimum for strain relief on wrapping and leads to significantly reduced risk of PZT fracture of wrapping stresses.

(iii) A rectangular slot bottom is in many cases the optimum for reduction of acoustic cross-talk.

(iv) The modified process removes the need for stringent height-control in the dicing process, and thus removes a demanding process parameter involving significant cost.

[0058] As a further aspect of the present invention there will now be described a modification of the transducer fabrication technique which could address both the shape and depth of the slot bottom.

[0059] This modified method is as follows:

(i) Double-metalize the ground-plane polyimide and wax both this and the ceramic spacer material to a ceramic carrier block. The ceramic carrier will be a low-density, low-cost PZT material, or some other machineable ceramic such as Macor or Shapal. The wax will be of a type soluble in a safe organic solvent, and capable of being pressed under controlled, elevated-temperature, conditions into a thin, uniform layer.

(ii) Bond the pre-poled, metalized, transducer block, of dimensions 3.2x0.8x0.05, to the ground-plane electrode and, the ground-plane electrode to the spacer using Hysol epoxy in a purpose-built assembly press.

(iii) Dice the transducer block whilst on the sacrificial ceramic carrier. The slot bottom depth will be such as to penetrate the ceramic carrier by a few tens of microns. By this means parallel-sided cuts in the PZT and ground-plane are achieved and each full array width is defined.

(iv) Invert the ceramic carrier block, ground-planes and transducer plates over the polyimide matching layer (flex-circuit) and epoxy bond in a temperature and pressure controlled press. This step involves accurate alignment of the transducer array and the flex-circuit. The alignment is achieved by dicing through the carrier ceramic block at, or close to, the perimeter of the transducer array, in order to allow the individual positioning of these arrays on the flex-circuit diaphragm. Alternative bonding processes are flip-chip solder and indium-gold. Epoxy-bonding would involve excess adhesive which may interfere with the laser ablation process.

(v) Remove the ceramic carrier by immersion of the flex-circuit in the chosen solvent. Remaining on the flex-circuit are the diced PZT arrays with their diced ground-planes, each array bonded to the polyimide flex circuit. Since the exposed surface of the ground-plane is metalized it acts as a reflector of the laser beam, whereas the polyimide does not.

(vi) Use the diced PZT -array and ground-plane assembly as a mask for ablation of the polyimide flex-circuit. Since the exposed surface of the ground-plane is metalized it acts as a reflector of the laser beam, whereas the polyimide in the slot bottom is exposed to the full-power of the laser and is ablated. Clearly, since the slot bottom shape is rectangular before ablation, there is a much greater chance of controlling the thinning to give, say, a 0.005 uniform layer of polyimide remaining after ablation. An alternative to this is to ablate the flex circuit before assembly using the tracks in the transducer area as a mask.

Claims

1. Apparatus for intravascular ultrasonic imaging, the apparatus comprising:
 - a catheter having an ultrasonic transducer array fabricated at least in part from non-polymeric electrostrictive material; and
 - a high permittivity ceramic member or layer that couples a common radiofrequency source to elements of the array
2. The apparatus of claim 1 further comprising controls for energising the array and processing signals derived therefrom, the controls being adapted to apply a bias voltage to elements of the array to render those elements substantially piezoelectric.
3. The apparatus of claim 1 or 2 in which the electrostrictive material is a relaxor ferroelectric material.
4. The apparatus of claim 3, wherein the electrostrictive material comprises lead magnesium niobate.
5. The apparatus of claim 2, wherein the controls are adapted to transmit and receive signals only while the bias voltage is applied.
6. The apparatus of claim 1 or 2 in combination with a multiplexer arrangement through which the transducer array is energised and through which echo signals received by the transducer array are passed to the proximal end of the catheter, when in use.
7. The apparatus of claim 6 in which the multiplexer arrangement comprises a plurality of integrated circuits.
8. The apparatus as claimed in claim 7 in which the integrated circuits are arranged in substantially cylindrical configuration,
9. The apparatus of claim 7 in which adjacent integrated circuits are spaced from one another by a slot.
10. The apparatus of claim 7, in which the integrated circuits are flip-chip bonded to an electrical circuit.
11. The apparatus of claim 10 in which the electrical circuit is a printed circuit.
12. A method of manufacturing a catheter for intravascular ultrasonic imaging having an ultrasonic transducer array fabricated at least in part from a non-polymeric, electrostrictive material, the method comprising:
 - fabricating the transducer in-the-flat; the transducer array comprising a high permittivity ceramic member or layer that couples a common radiofrequency source to elements of the array; and
 - reconfiguring the array into a substantially cylindrical configuration.
13. The method of claim 12 further comprising electrically coupling controls to the array for energising the array and processing signals derived therefrom, the controls being adapted to apply a bias voltage to elements of the array to render those elements substantial piezoelectric.
14. The method of claim 12 or 13, wherein fabricating the transducer array in-the-flat further comprises:
 - providing a substrate;
 - forming electrically conductive tracks on the substrate;
 - bonding a piezoelectric block to the conductive tracks; and
 - forming slots in the piezoelectric block to form a plurality of discrete transducer elements.
15. The method of claim 14, further comprising coupling at least one multiplexer circuit to the conductive tracks.
16. The method of claim 13, wherein the electrostrictive material comprises a relaxor ferroelectric material.
17. The method of claims 15, wherein the relaxor ferroelectric material comprises lead magnesium niobate.

18. The method of claim 14, further comprising forming slot bottoms in the substrate adjacent the electrically conductive tracks prior to bonding the piezoelectric block to the conductive tracks.
19. The method of claim 18, wherein forming slot bottoms comprises forming slot bottoms with a laser.
20. The method of claim 18, further comprising performing a photoresist technique within the slot bottoms.

Patentansprüche

1. Gerät zur intravaskulären Ultraschallabbildung, das Gerät umfassend:
- einen Katheter mit einem Ultraschallwandlerarray, zumindest teilweise aus einem nichtpolymeren elektroatriktiven Material hergestellt; und
ein keramisches Element oder eine keramische Schicht hoher Dielektrizitätskonstante, die eine gemeinsame Hochfrequenzquelle an die Arrayelemente ankoppeln.
2. Gerät des Anspruchs 1, weiter Regler zur Stromversorgung des Arrays und zur Verarbeitung der davon abgenommenen Signale umfassend, wobei die Regler so ausgelegt sind, dass sie eine Vorspannung an Arrayelemente anlegen, um diese Elemente im Wesentlichen piezoelektrisch zu machen.
3. Gerät des Anspruchs 1 oder 2, **dadurch gekennzeichnet, dass** das elektrostriktive Material ein ferroelektrisches Relaxor-Material ist.
4. Gerät des Anspruchs 3, **dadurch gekennzeichnet, dass** das elektrostriktive Material Bleimagne-siumniobat umfasst.
5. Gerät des Anspruchs 2, **dadurch gekennzeichnet, dass** die Regler so ausgelegt sind, dass sie Signale nur dann übertragen und empfangen, wenn die Vorspannung anliegt.
6. Gerät des Anspruchs 1 oder 2 in Verbindung mit einer Multiplexeranordnung, durch die das Wandlerarray mit Strom versorgt wird und durch die vom Wandlerarray empfangene Echosignale zum proximalen Ende des Katheters weitergeleitet werden, wenn in Betrieb.
7. Gerät des Anspruchs 6, **dadurch gekennzeichnet, dass** die Multiplexeranordnung eine Mehrzahl integrierter Schaltungen umfasst.

8. Gerät, wie in Anspruch 7 beansprucht, **dadurch gekennzeichnet, dass** die integrierten Schaltungen in einer im Wesentlichen zylindrischen Konfiguration angeordnet sind.

5

9. Gerät des Anspruchs 7, **dadurch gekennzeichnet, dass** benachbarte integrierte Schaltungen darin voneinander durch einen Schlitz beabstandet sind.

10

10. Gerät des Anspruchs 7, **dadurch gekennzeichnet, dass** die integrierten Schaltungen darin an eine elektrische Schaltung flipchip-gebondet sind.

15

11. Gerät des Anspruchs 10, **dadurch gekennzeichnet, dass** die elektrische Schaltung darin eine gedruckte Schaltung ist.

20

12. Verfahren zur Herstellung eines Katheters zur intravaskulären Ultraschallabbildung mit einem Ultraschallwandlerarray, das zumindest teilweise aus einem nichtpolymeren, elektrostriktiven Material hergestellt ist, das Verfahren umfassend:

25

den Wandler flach ausgelegt herzustellen; wobei das Wandlerarray ein keramisches Element oder eine keramische Schicht hoher Dielektrizitätskonstante umfasst, die eine gemeinsame Hochfrequenzquelle an Elemente des Arrays ankoppeln; und

30

das Array zu einer im Wesentlichen zylindrischen Konfiguration umzukonfigurieren.

35

13. Verfahren des Anspruchs 12, weiter umfassend, Regler zur Stromversorgung des Arrays und zur Verarbeitung der davon abgenommenen Signale elektrisch an das Array anzuschliessen, wobei die Regler so ausgelegt sind, dass sie eine Vorspannung an Arrayelemente anlegen, um diese Elemente im Wesentlichen piezoelektrisch zu machen.

40

14. Verfahren des Anspruchs 12 oder 13, **dadurch gekennzeichnet, dass** die Herstellung des flach ausgelegten Wandlerarrays weiter umfasst:

45

ein Substrat zur Verfügung zu stellen; elektrisch leitende Bahnen auf dem Substrat auszubilden;

50

einen piezoelektrischen Block auf die leitenden Bahnen zu banden; und
Schlitze im piezoelektrischen Block auszubilden, um eine Mehrzahl von diskreten Wandler-elementen auszubilden.

55

15. Verfahren des Anspruchs 14, weiter umfassend, zumindest eine Multiplexerschaltung an die leitenden Bahnen anzukoppeln.

16. Verfahren des Anspruchs 13, **dadurch gekenn-**

zeichnet, dass das elektrostriktive Material ein ferroelektrisches Relaxor-Material umfasst.

17. Verfahren des Anspruchs 15, **dadurch gekennzeichnet, dass** das ferroelektrische Relaxor-Material Bleimagnesiumniobat umfasst. 5
18. Verfahren des Anspruchs 14, weiter umfassend, vor dem Bonden des piezoelektrischen Blocks auf die elektrisch leitenden Bahnen in Nachbarschaft zu den leitenden Bahnen Schlitzböden im Substrat auszubilden. 10
19. Verfahren des Anspruchs 18, **dadurch gekennzeichnet, dass** die Ausbildung von Schlitzböden umfasst, Schlitzböden mit einem Laser zu bilden. 15
20. Verfahren des Anspruchs 18, weiter umfassend, eine Fotoresisttechnik innerhalb der Schlitzböden auszuführen. 20

Revendications

1. Dispositif d'imagerie intravasculaire par ultrasons, le dispositif comprenant : 25
- un cathéter comportant un réseau de transducteurs à ultrasons fabriqué au moins en partie à partir d'un matériau électrostrictif non polymère, et 30
- un élément ou une couche de céramique de permittivité élevée qui relie une source commune de radiofréquence à des éléments du réseau. 35
2. Dispositif selon la revendication 1, comprenant en outre des commandes pour alimenter le réseau et traiter des signaux obtenus de celui-ci, les commandes étant conçues pour appliquer une tension de polarisation aux éléments du réseau pour rendre ces éléments pratiquement piézoélectriques. 40
3. Dispositif selon la revendication 1 ou 2, dans lequel le matériau électrostrictif est un matériau ferroélectrique relaxeur. 45
4. Dispositif selon la revendication 3, dans lequel le matériau électrostrictif comprend du niobate de plomb magnésium. 50
5. Dispositif selon la revendication 2, dans lequel les commandes sont conçues pour émettre et recevoir des signaux seulement lorsque la tension de polarisation est appliquée. 55
6. Dispositif selon la revendication 1 ou 2 en combinaison avec un agencement de multiplexeur à tra-

vers lequel le réseau de transducteurs est alimenté et à travers lequel les signaux d'écho reçus par le réseau de transducteurs sont transférés vers l'extrémité proximale du cathéter quand il est en utilisation.

7. Dispositif selon la revendication 6, dans lequel l'agencement de multiplexeur comprend une pluralité de circuits intégrés.
8. Dispositif selon la revendication 7, dans lequel les circuits intégrés sont disposés selon une configuration pratiquement cylindrique.
9. Dispositif selon la revendication 7, dans lequel des circuits intégrés agencés sont espacés les uns des autres par une encoche.
10. Dispositif selon la revendication 7, dans lequel les circuits intégrés sont des puces à bosses soudées à un circuit électrique.
11. Dispositif selon la revendication 10, dans lequel le circuit électrique est un circuit imprimé.
12. Procédé de fabrication d'un cathéter destiné à former des images intravasculaires par ultrasons comportant un réseau de transducteurs à ultrasons constitué au moins en partie en un matériau électrostrictif non polymère, le procédé comprenant : 30
- la fabrication du transducteur à plat, le réseau de transducteurs comprenant un élément ou une couche de céramique à haute permittivité qui relie une source radiofréquence commune aux éléments du réseau, et 35
- la reconfiguration du réseau en une configuration pratiquement cylindrique.
13. Procédé selon la revendication 12 comprenant en outre le couplage électrique des commandes au réseau pour alimenter le réseau et traiter les signaux obtenus de celui-ci, les commandes étant conçues pour appliquer une tension de polarisation aux éléments du réseau pour rendre ces éléments pratiquement piézoélectriques.
14. Procédé selon la revendication 12 ou 13, dans lequel la fabrication du réseau de transducteurs à plat ou autre comprend : 50
- la fourniture d'un substrat,
- la formation de pistes conductrices électriques sur le substrat,
- la liaison d'un bloc piézoélectrique aux pistes conductrices, et 55
- la formation d'encoches dans le bloc piézoélectrique pour former une pluralité d'éléments

transducteurs discrets.

- 15.** Procédé selon la revendication 14, comprenant en outre le couplage d'au moins un circuit de multiplexeur aux pistes conductrices. 5
- 16.** Procédé selon la revendication 13, dans lequel le matériau électrostrictif comprend un matériau ferroélectrique relaxeur. 10
- 17.** Procédé selon la revendication 15, dans lequel le matériau ferroélectrique relaxeur comprend du niobate de plomb magnésium.
- 18.** Procédé selon la revendication 14, comprenant en outre la formation de fonds d'encoches dans le substrat à côté des pistes électriquement conductrices avant de lier le bloc piézoélectrique aux pistes conductrices. 15
20
- 19.** Procédé selon la revendication 18, où la formation de fonds d'encoches comprend la formation de fonds d'encoches avec un laser.
- 20.** Procédé selon la revendication 19 comprenant en outre l'application d'une technique de photorésist à l'intérieur des fonds d'encoches. 25

30

35

40

45

50

55

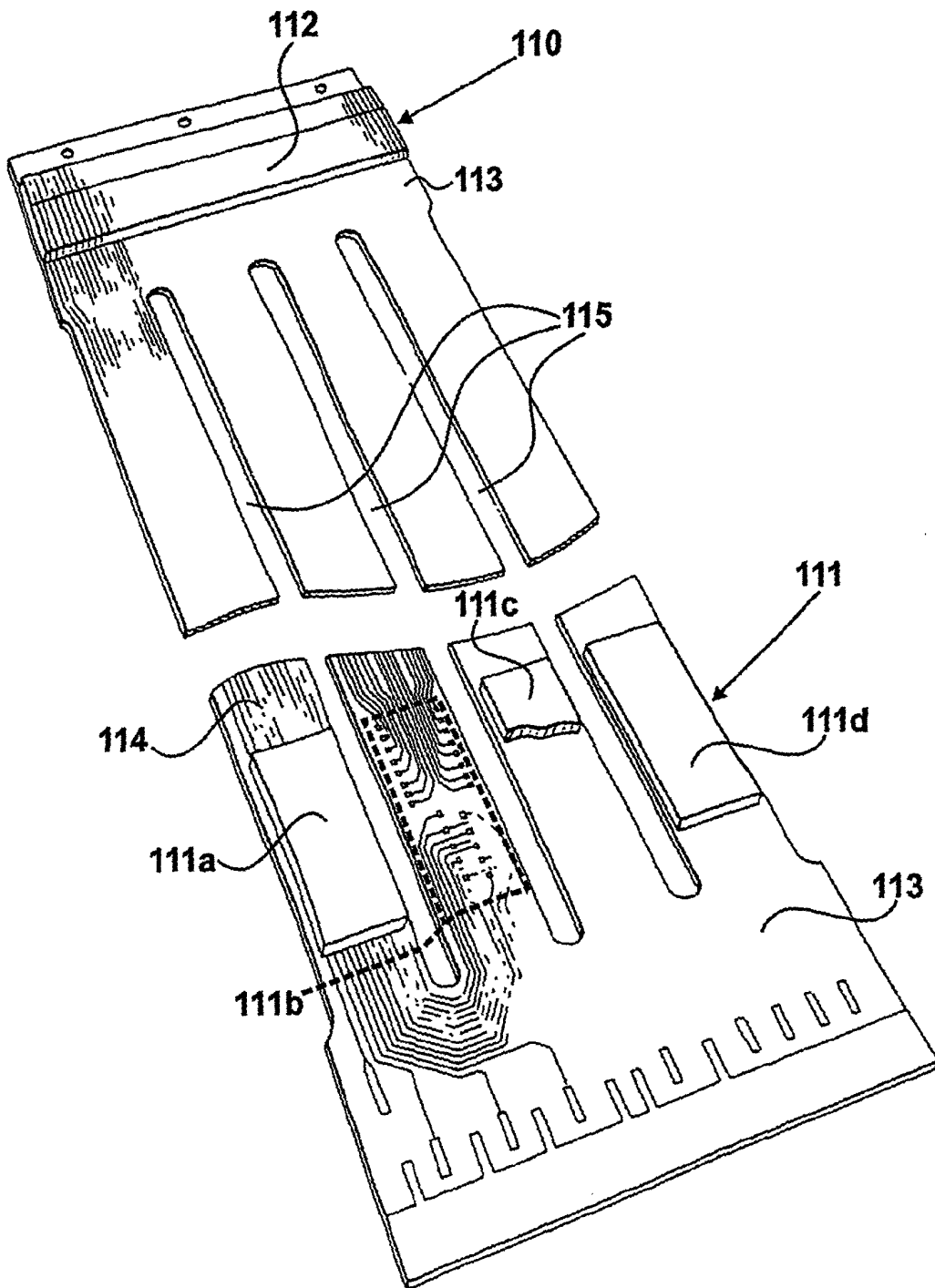

Figure 1

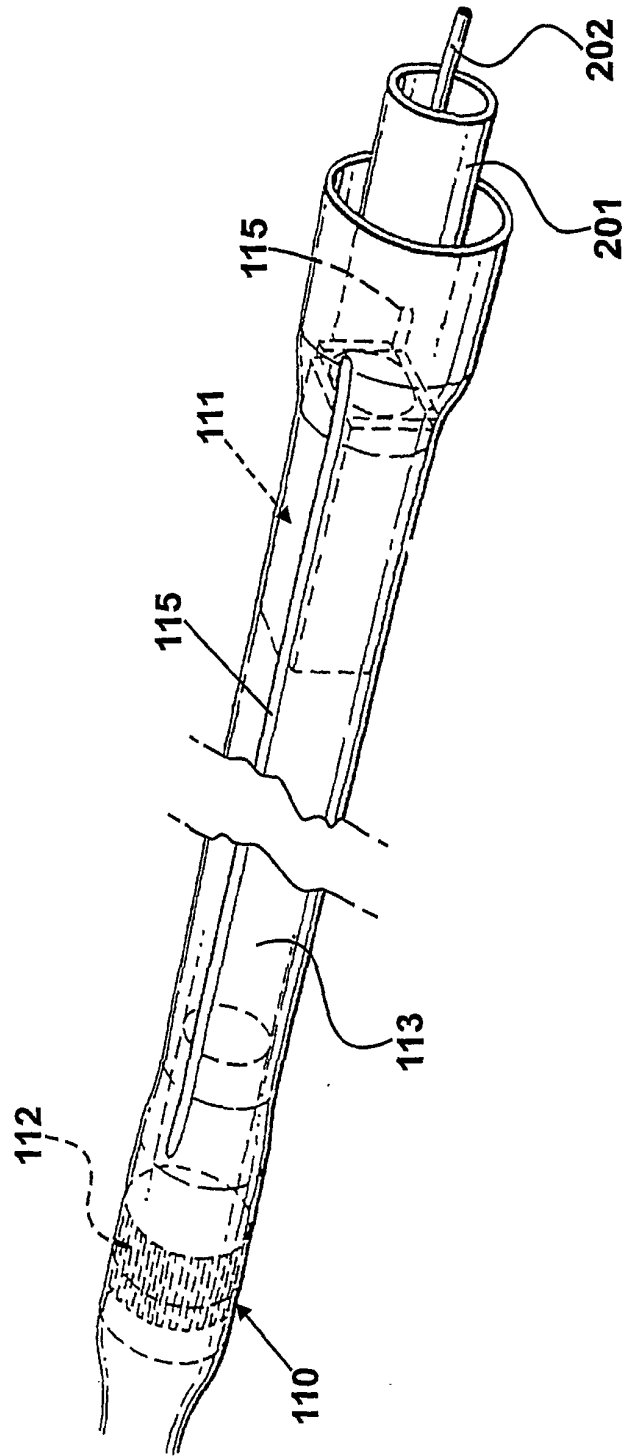

Figure 2

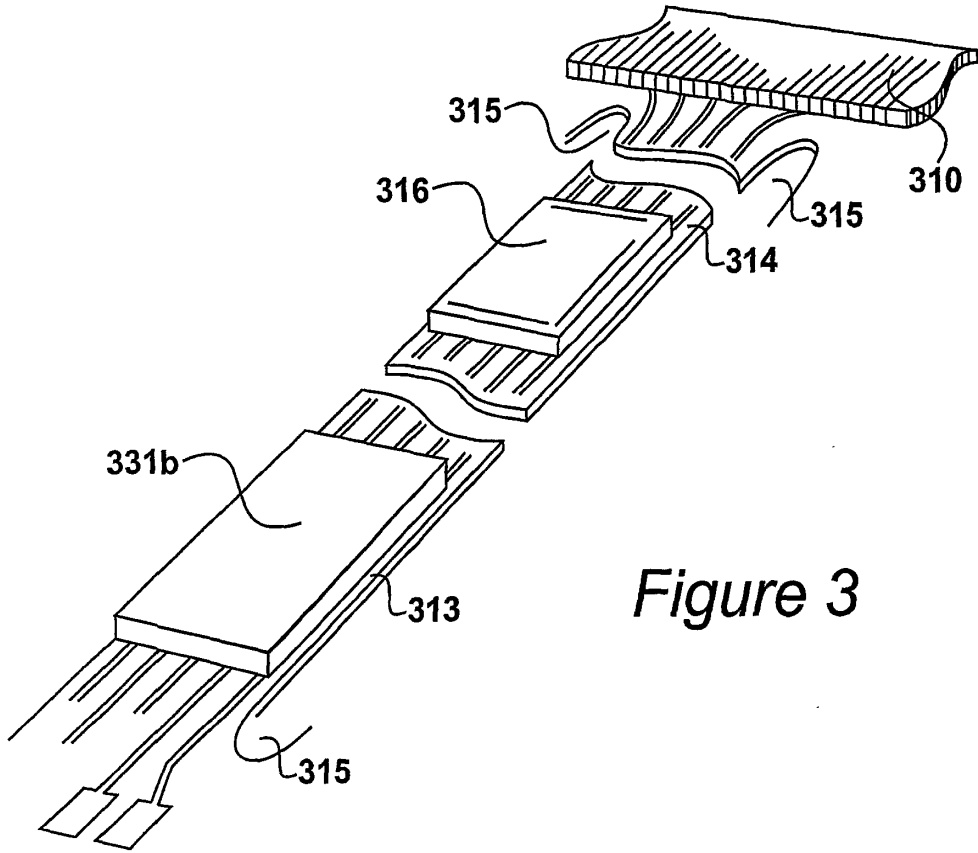

Figure 3

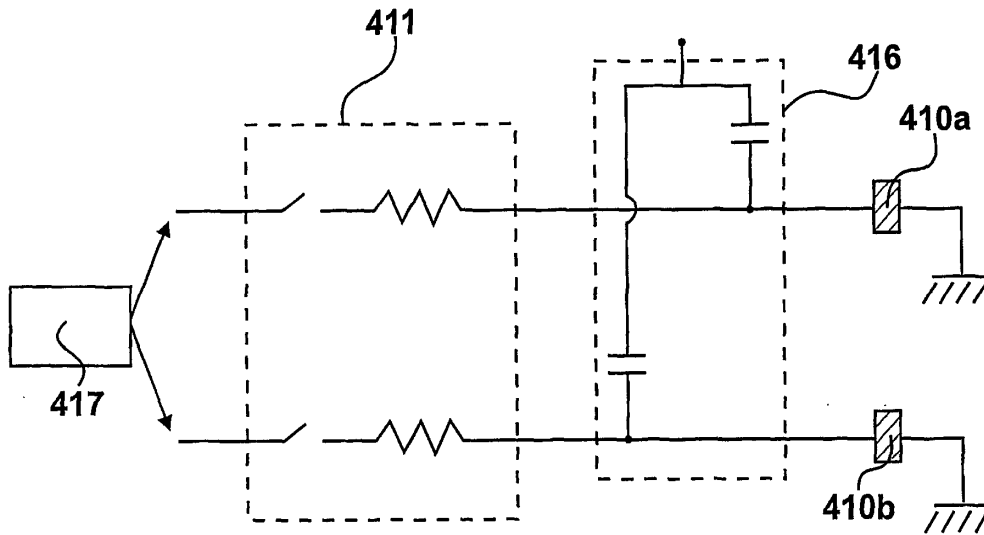

Figure 4

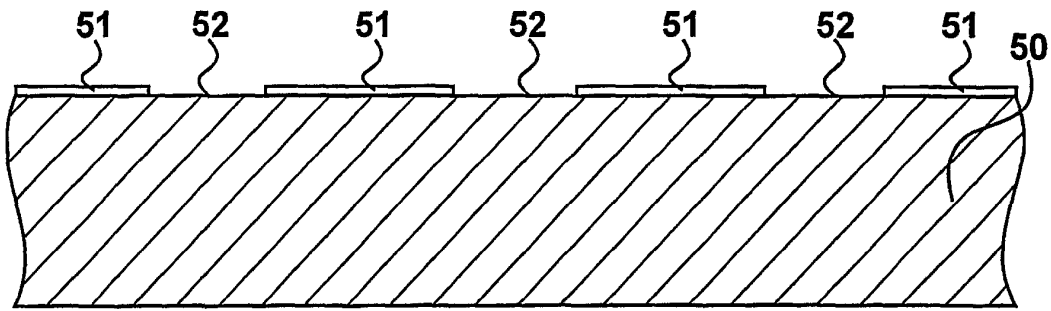

Figure 5

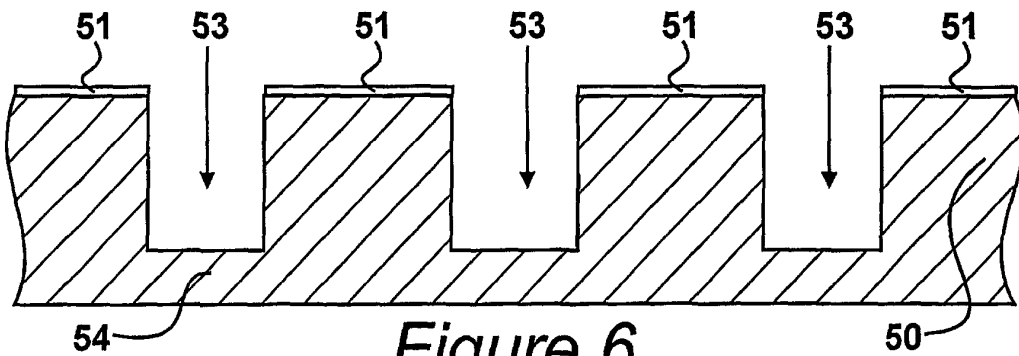

Figure 6

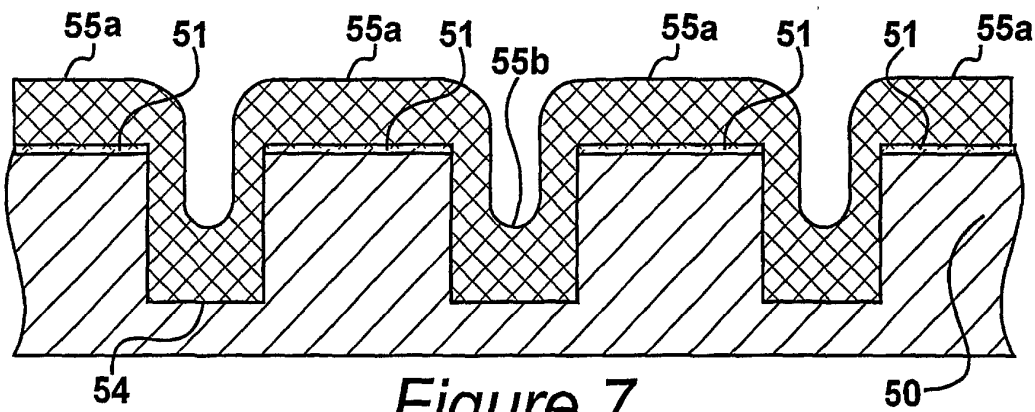

Figure 7

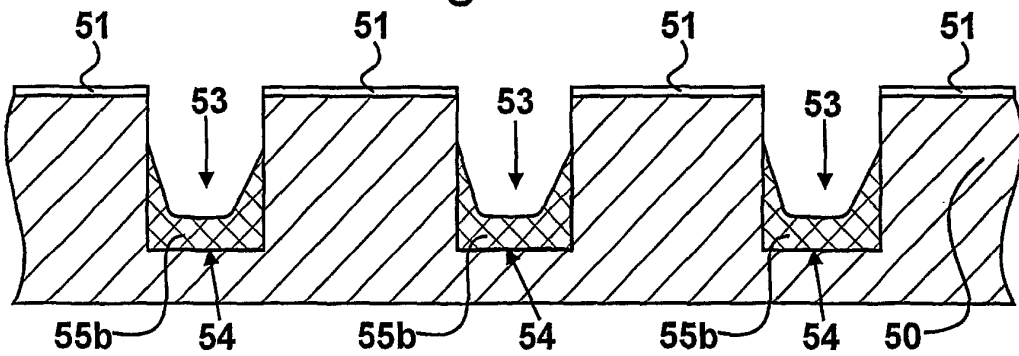

Figure 8

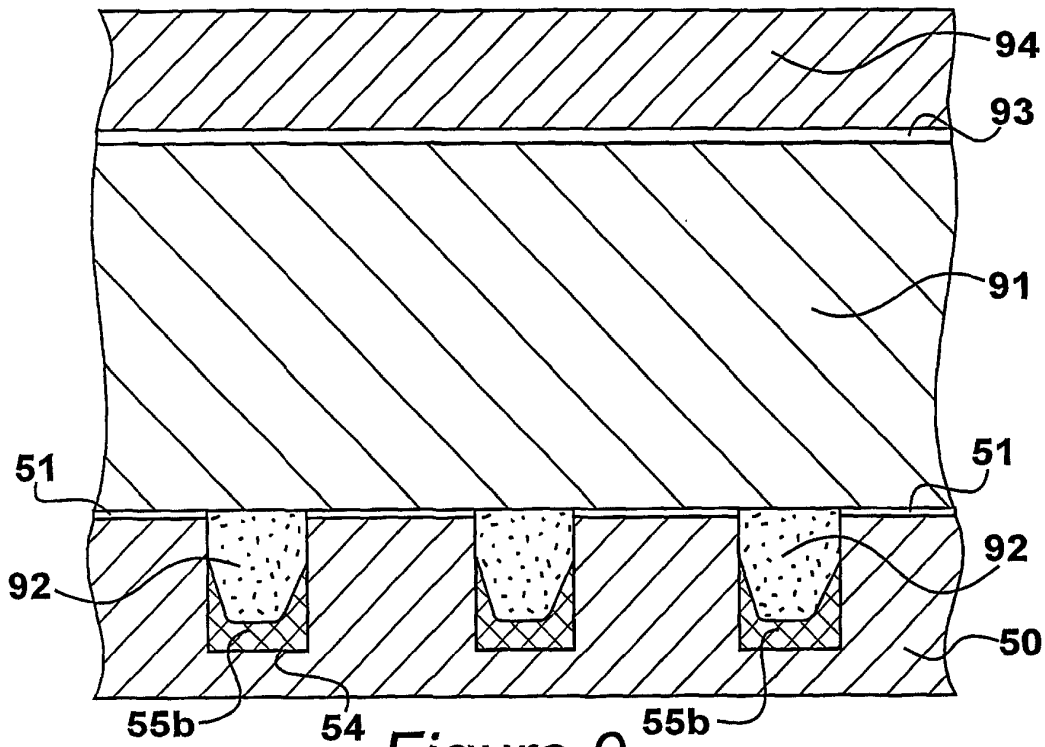

Figure 9

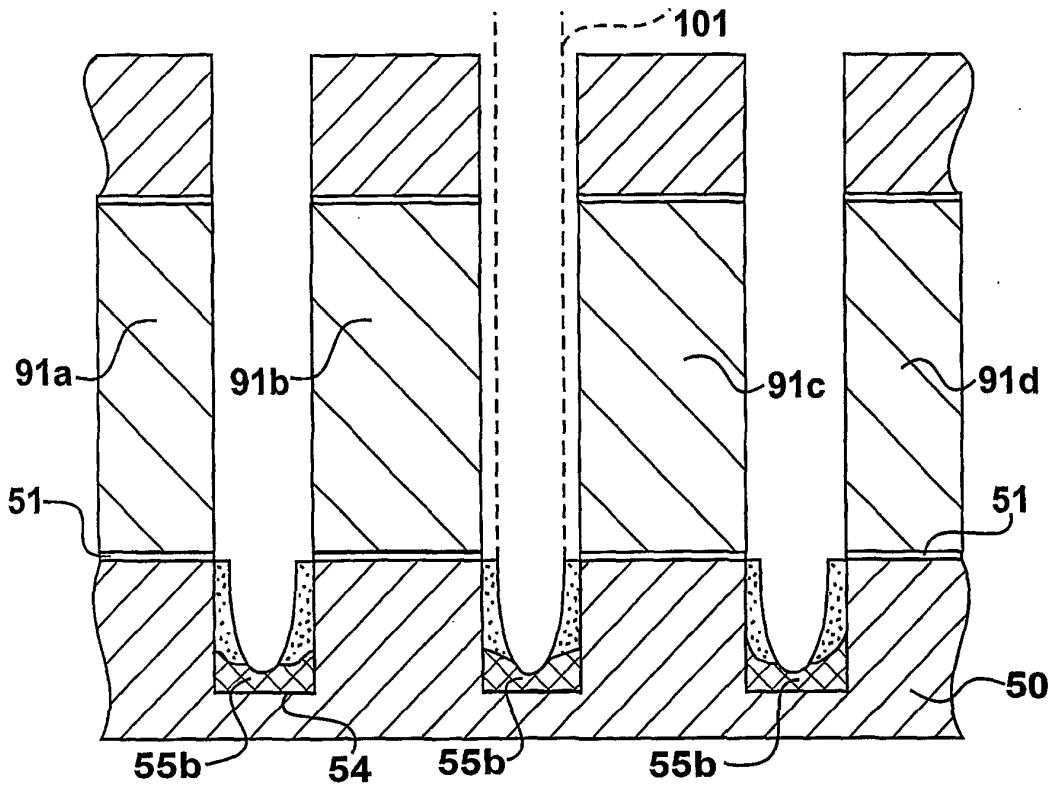

Figure 10

专利名称(译)	血管内超声导管		
公开(公告)号	EP1324702B1	公开(公告)日	2004-05-19
申请号	EP2001974506	申请日	2001-10-11
[标]申请(专利权)人(译)	JOMED IMAGING		
申请(专利权)人(译)	JOMED IMAGING LIMITED		
当前申请(专利权)人(译)	JOMED IMAGING LIMITED		
[标]发明人	DICKINSON ROBERT NIX ELVIN		
发明人	DICKINSON, ROBERT NIX, ELVIN		
IPC分类号	A61B8/12 B06B1/06 G01S15/89 H04R17/00		
CPC分类号	A61B8/12 A61B8/445 A61B8/4488 A61B8/4494 B06B1/06 B06B1/0622 G01S15/8915		
优先权	2000025250 2000-10-14 GB		
其他公开文献	EP1324702A1		
外部链接	Espacenet		

摘要(译)

用于血管内超声成像的装置包括导管，该导管具有至少部分地由电致伸缩材料制成的超声换能器阵列，其中电致伸缩材料是非聚合的。

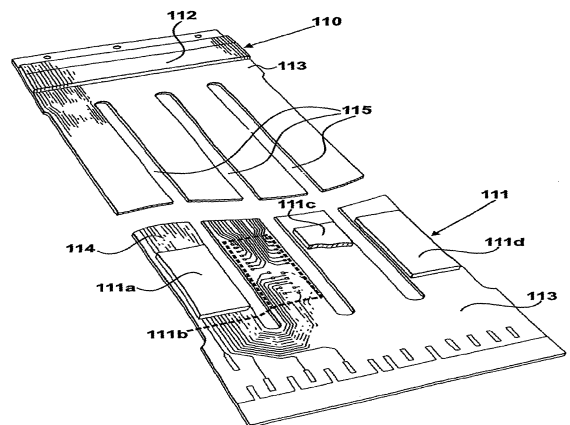

Figure 1