



(12) **EUROPEAN PATENT APPLICATION**

(43) Date of publication: **04.10.2001 Bulletin 2001/40** (51) Int Cl.⁷: **A61B 8/13**

(21) Application number: **01302344.5**

(22) Date of filing: **14.03.2001**

(84) Designated Contracting States:
**AT BE CH CY DE DK ES FI FR GB GR IE IT LI LU
 MC NL PT SE TR**
 Designated Extension States:
AL LT LV MK RO SI

(72) Inventors:
 • **Nakamura, Mitsuyuki**
Yokohama-shi, Kanagawa-ken 240-0042 (JP)
 • **Kosaka, Noboru**
Mitaka-shi, Tokyo 181-0004 (JP)

(30) Priority: **28.03.2000 JP 2000087851**

(74) Representative: **Rackham, Stephen Neil**
GILL JENNINGS & EVERY,
Broadgate House,
7 Eldon Street
London EC2M 7LH (GB)

(71) Applicant: **MATSUSHITA ELECTRIC INDUSTRIAL
 CO., LTD.**
Kadoma-shi, Osaka 571-8501 (JP)

(54) **Tomographic ultrasonic diagnostic apparatus**

(57) The ultrasonic diagnostic apparatus of the present invention comprises an operation panel 11 through which different diagnostic conditions are set, a system controller 12 for controlling the frequency of the ultrasonic wave to be transmitted according to the field of view, a transmitting circuit 13 for transmitting ultra-

sonic wave, a receiving circuit 15 for receiving the reflected wave from an ultrasonic probe 14 to convert the reflected wave into an electric signal, an image processing unit 16 for applying the predetermined processing to the signal from the receiving circuit 15 and a display unit 17 for displaying tomographic image on the basis of the electric signal from the image processing apparatus 16.

FIG. 1

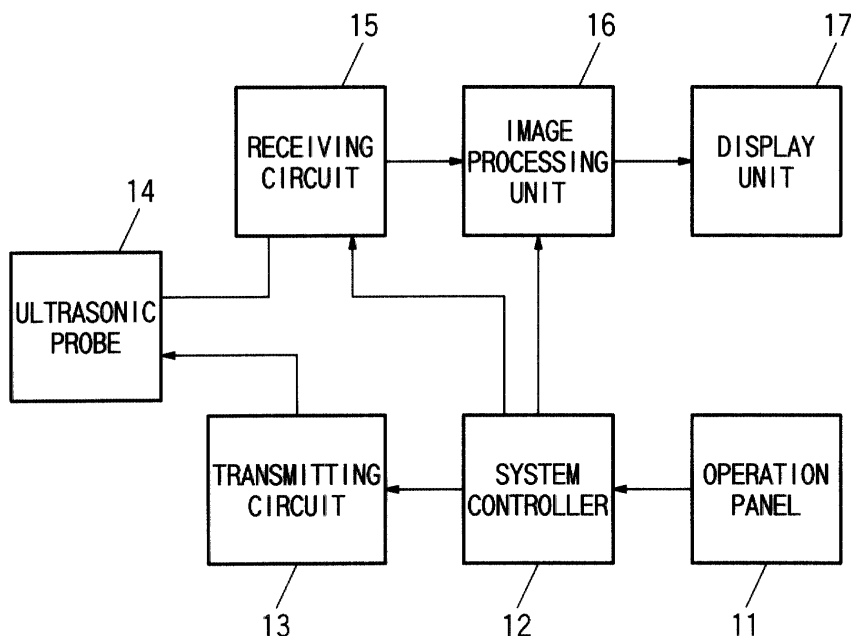

Description

[0001] The present invention relates to an ultrasonic diagnostic apparatus for transmitting an ultrasonic wave to a living body and receiving a wave reflected by the living body to produce a tomographic image from the reflected wave.

[0002] An ultrasonic diagnostic apparatus has been conventionally used for medical diagnosis for the purpose of producing organic information of a living body or a patient. This ultrasonic diagnostic apparatus transmits an ultrasonic pulse into an organ of the patient through an ultrasonic probe and receives the reflected wave from a boundary surface between tissues different in acoustic impedance through the ultrasonic probe to convert the reflected wave into an electric signal. Further, the ultrasonic diagnostic apparatus displays an ultrasonic tomographic image on a monitor on the basis of the electric signal.

[0003] In such a ultrasonic diagnostic apparatus, the depth from the organic surface in which an ultrasonic tomographic image can be produced, namely, a limit of visible depth becomes shallower the higher frequency of ultrasonic wave is used for diagnosis because an ultrasonic wave is heavily absorbed by the organ in proportional to the frequency of the ultrasonic wave. However, it is desirable to use a high frequency wave in order to produce an ultrasonic tomographic image of a high resolution.

[0004] In transmission of an ultrasonic wave, it is desirable to increase the frequency of the ultrasonic wave to be transmitted in order to increase the resolution of a target region for diagnosis. However, even if the depth set to be displayed on the monitor, namely, the depth of field of view is set deep, the limit of visible depth is constant because the frequency of the ultrasonic wave to be transmitted is constant.

[0005] Conventionally, the ultrasonic diagnostic apparatus as described in Japanese Patent Public Disclosure No. 6-54850 is well known. The construction of this apparatus is shown in Fig. 5. In Fig. 5, a system controller 112 controls a drive frequency for an ultrasonic probe 115 according to a focus position, a color display area or a Doppler signal detection position. According to this apparatus, the frequency of the ultrasonic wave is changed according to the focus position, the color display area or the Doppler signal detection position.

[0006] However, the conventional apparatus as set forth above has disadvantages that even if the depth of field of view is set deep in order to display the diagnostic target region, the visual depth limit does not change because the transmitting frequency does not change and as a result, it is difficult to produce organic information on the area surrounding the diagnostic target region.

[0007] Further, the conventional apparatus has disadvantages that even if the depth of field of view is set shallow in order to display the diagnostic target region, the resolution of the diagnostic target region does not change because the transmitting frequency does not change and as a result, it is difficult to produce an image of high resolution.

[0008] Further, the conventional apparatus has disadvantages that even if the enlargingly displayed area of field of view is set deep in order to enlargingly display the diagnostic target region, the visible depth limit does not change because the transmitting frequency does not change and as a result, it is difficult to produce organic information on the area surrounding the enlargingly displayed area of field of view.

[0009] Further, the conventional apparatus has disadvantages that even if the enlargingly displayed area of field of view is set shallow in order to enlargingly display the diagnostic target region, the resolution of the enlargingly displayed area of field of view does not change because the transmitting frequency does not change and as a result, it is difficult to produce an image of high resolution.

[0010] Further, the conventional apparatus has disadvantages that even if the field of view is changed, the transmitting frequency cannot be changed without changing the focus position, the color display area or the Doppler signal detection position in the field of view.

[0011] It is an object of the present invention to solve the problem set forth above in the prior art and to provide an improved ultrasonic diagnostic apparatus capable of automatically changing an ultrasonic wave to be transmitted according to the field of view.

[0012] The ultrasonic diagnostic apparatus of the present invention comprises ultrasonic transmitting/receiving means for transmitting an ultrasonic wave to a living body and receiving a wave reflected from the living body to convert the reflected wave into an electric signal, control means for controlling the frequency of the ultrasonic wave to be transmitted by the ultrasonic transmitting/receiving means according to a field of view, and display means for displaying a diagnostic image on the basis of the electric signal from the ultrasonic transmitting/receiving means. In this arrangement, the frequency of the ultrasonic wave to be transmitted by the ultrasonic transmitting/receiving means can be automatically changed according to the field of view.

[0013] In the ultrasonic diagnostic apparatus of the present invention, the control means may be arranged to control the frequency of the ultrasonic wave to be transmitted by the ultrasonic transmitting/receiving means according to the depth of field of view. In this arrangement, the frequency of the ultrasonic wave to be transmitted by the ultrasonic transmitting/receiving means can be automatically changed according to the depth of field of view.

[0014] In the ultrasonic diagnostic apparatus of the present invention, the control means may be arranged to control the frequency of the ultrasonic wave to be transmitted by the ultrasonic transmitting/receiving means according to the

position of the enlargingly displayed area of field of view. In this arrangement, the frequency of the ultrasonic wave to be transmitted by the ultrasonic transmitting/receiving means can be automatically changed according to the position of the enlargingly displayed area of field of view.

5 [0015] In the ultrasonic diagnostic apparatus of the present invention, in addition to an arrangement comprising ultrasonic transmitting/receiving means for transmitting an ultrasonic wave to a living body and receiving a wave re-
flected from the living body to convert the reflected wave into an electric signal, control means for controlling the
frequency of the ultrasonic wave to be transmitted by the ultrasonic transmitting/receiving means according to a field
of view, and display means for displaying a diagnostic image on the basis of the electric signal from the ultrasonic
10 transmitting/receiving means, the ultrasonic diagnostic apparatus may be arranged to further include a rewritable re-
tention table for diagnostic condition data. In the arrangement, a user can change easily such a setting that the fre-
quency of the ultrasonic wave to be transmitted by the ultrasonic transmitting/receiving means can be automatically
changed according to the field of view.

[0016] Particular embodiments will now be described with reference to the accompanying drawings; in which:-

[0017] Fig. 1 shows a construction view of the first embodiment of the present invention.

15 [0018] Fig. 2 show a view for illustrating the operation of the present invention.

[0019] Fig. 3 shows a flowchart for illustrating the operation of the present invention.

[0020] Fig. 4 shows a construction view of the second embodiment of the present invention.

[0021] Fig. 5 shows a construction view of prior art.

20 [0022] The embodiments of the present invention will be described hereinafter using the drawings. Fig. 1 shows the
first embodiment of the present invention. An operation panel 11 is adapted to allow a user to set different diagnostic
conditions. For example, the user can make selection of diagnostic modes, etc., and settings of the depth of field of
view, the enlargingly displayed area of field of view and the like. The information set through the operation panel 11 is
supplied to a system controller 12.

25 [0023] The system controller 12 is adapted to control the whole system, particularly, to determine the frequency of
the ultrasonic wave to be transmitted from an ultrasonic probe 14 according to the field of view set through the operation
panel 11. The system controller 12 determines to transmit an ultrasonic wave of low frequency when the depth of field
of view is set to deep level and to transmit an ultrasonic wave of high frequency when the depth of field of view is set
to shallow level. The ultrasonic probe used in this embodiment has a wide frequency range or ultrasonic elements of
two or more different types, for example, the ultrasonic probe is designed so that it can transmit and receive ultrasonic
30 waves of 5.0-7.5 MHz.

35 [0024] One example of the method for determining the ultrasonic wave frequency set forth above will be described
with reference to Figs. 2 and 3. Fig. 2 shows the case of mechanical sector. In the present embodiment, the ultrasonic
waves of three different frequencies of 5.0, 6.0 and 7.5 MHz are transmitted. In Fig. 2, reference numeral 20 designates
the maximum field of view when the ultrasonic wave of 5.0 MHz is transmitted. Arc 21 shows the maximum depth of
field of view when the ultrasonic wave 5.0 MHz is transmitted. Arcs 22, 23 and 24 show the limit of visible depth when
the frequency of the ultrasonic wave is 5.0, 6.0 and 7.5 MHz respectively. Reference numerals 31, 32, 33 and 34
designate respectively the areas surrounded by these arcs 21, 22, 23 and 24. It is determined that the ultrasonic wave
of 5.0 MHz is transmitted when the depth of field of view is set to the areas 31 and 32, the ultrasonic wave of 6.0 MHz
is transmitted when the depth of field of view is set to the area 33, the ultrasonic wave of 7.5 MHz is transmitted when
40 the depth of field of view is set to the area 34.

45 [0025] In conventional case, the limit of visible depth is the arc 23 in Fig. 2 when the ultrasonic wave of 6.0 MHz is
transmitted. In the present invention, the drive frequency for the ultrasonic probe 14 is determined as set forth above,
whereby the ultrasonic wave of 5.0 MHz is transmitted when the depth of field of view is set in the area 32, and as a
result, the limit of visible depth becomes the arc 22. Consequently, the field of view is extended by the portion of the
area 32 over the conventional apparatus. The information concerning the tissue surrounding the diagnostic target
region can be obtained as an image to improve the accuracy of the diagnosis. If the depth of field of view is set to the
shallow level, the ultrasonic wave of high frequency is transmitted. As a result, the resolution is improved over the
conventional apparatus. The case of mechanical sector probe has been described hereinbefore and alternatively, an
array probe and the like can be used. There is no limitation on the type of ultrasonic probe.

50 [0026] A transmitting circuit 13 generates a master signal therein and converts a trigger signal of the frequency
determined by the system controller 12 into a pulse signal of high voltage on the basis of the frequency of the master
signal and then the pulse signal is applied to the ultrasonic probe 14. The ultrasonic probe 14 transmits an ultrasonic
wave into the living body or the organ of the patient in response to the pulse signal and receive a wave reflected from
the organ of the patient and converts the reflected wave to an electric signal. This electric signal is input to a receiving
55 circuit 15 in a back stage. The receiving circuit 15 applies the predetermined amplification and detection, etc. to the
electric signal and supplies the signal to an image processing unit 16. The image processing unit 16 applies the pre-
determined processing to the signal from the receiving circuit 15 and displays the signal on a display unit 17 as a
diagnostic image. The operation of the ultrasonic diagnostic apparatus set forth above will be described hereinafter.

[0027] A case where B mode is selected through the operation panel 11 will be described. When the depth of field of view is set through the operation panel 14, the information concerning the set depth of field of view is supplied to the system controller 12. The system controller 12 determines the driving frequency for the ultrasonic probe 14 in response to the depth of field of view. For example, the frequency is determined to be set to 5.0 MHz if the set depth of field of view is in the area 32 in Fig. 2. The information concerning the frequency is supplied to the transmitting circuit 13. The transmitting circuit 13 converts the trigger signal of the frequency determined by the system controller 12 into the pulse signal of high voltage and then, the pulse signal is applied to the ultrasonic probe 14. The ultrasonic wave transmitted from the ultrasonic probe 14 in response to the pulse signal is reflected by the different tissues of the patient body and received by the ultrasonic probe 14 and then, converted into an electric signal. This electric signal is input to the receiving circuit 15 in the back stage. The receiving circuit 15 applies amplification and detection, etc. to the electric signal and supplies the electric signal to the image processing unit 16. The image processing unit 16 implements processing such as scan transform or brightness transform to the electric signal and supplies the processed electric signal to the display unit 17 as image data. The display unit 17 displays the image data as an ultrasonic diagnostic image.

[0028] The advantage of the apparatus set forth above is that if the depth of field of view is set according to the position of diagnostic target region, an ultrasonic wave which frequency corresponds to the depth of field of view is transmitted, and therefore, information concerning the area surrounding the diagnostic target region is obtained, and if the depth of field of view is set shallow, an image of high resolution can be obtained.

[0029] Further, the advantage of the apparatus is that an ultrasonic wave which frequency corresponds to the depth of field of view is transmitted and therefore, if the depth of field of view is set deep, the limit of visible depth becomes deep whereby it becomes easy to see the diagnostic image, and as a result, the accuracy of diagnosis is improved.

[0030] Further, the advantage of the apparatus is that an ultrasonic wave which frequency corresponds to the position of enlargingly displayed area of field of view is transmitted, and therefore, if the enlargingly displayed area of field of view is set shallow, an image of high resolution can be obtained.

[0031] Further, the advantage of the apparatus is that an ultrasonic wave which frequency corresponds to the position of the enlargingly displayed area of field of view is transmitted and therefore, if the enlargingly displayed area of field of view is set deep, the limit of visible depth becomes deep, whereby it becomes easy to see the enlargingly displayed diagnostic image, and as a result, the accuracy of diagnosis is improved.

[0032] According to the embodiment as described hereinbefore, ultrasonic waves of three different frequencies are transmitted. However, it is intended to include two or more different frequencies. Further, it is not intended to limit the present invention to the embodiment described hereinbefore. Many modifications are possible within the scope of the present invention defined in the appended claims.

[0033] The second embodiment of the present invention will be now described using Fig. 4. As shown in Fig. 4, the second embodiment of the present invention is different from the first embodiment as set forth above in further including a rewritable table 18. The content of the table displayed on the TV monitor is easily rewritable by the user through the operation panel 11. The system controller 12 checks the rewritable table 18 on the basis of the information concerning the field of view set through the operation panel 11 and controls the transmitting circuit 13 to change the frequency of the ultrasonic wave to be transmitted.

[0034] Control of the frequency of the ultrasonic wave to be transmitted with respect to the depth of field of view will be hereinafter described by way of example.

[0035] Table 1 shows one example of the contents of the rewritable table 18.

Table 1

Depth Of Field Of View	Frequency Of Ultrasonic Wave To Be Transmitted
from 20 mm or more to less than 50 mm	7.5MHz
from 50 mm or more to less than 120 mm	6.0MHz
120 mm or more	5.0MHz

[0036] The value of the depth of field of view shown in Table 1 is displayed on the display unit 17 whereby the user can easily rewrite the value of the depth of field of view through the operation panel 11.

[0037] The degree of absorption of ultrasonic wave into the patient body varies with type of the patient body. The degree of absorption of ultrasonic wave into the patient body varies with different target organs in the diagnostic field such as abdominal area, obstetric area, etc. Since the degree of absorption of ultrasonic wave into patient body changes, the limit of visible depth also changes even if the transmitting frequency is constant.

[0038] According to this construction, the user can easily change the setting wherein the frequency of the ultrasonic wave to be transmitted from the ultrasonic transmitting/receiving means according to the field of view is automatically changed, and therefore, it is easy to compensate in response to the change of limit of visible depth.

[0039] It is possible to rewrite the value of transmitting frequency and keep storing the combination of the values. In the Table, three different ranges are set, but it is possible to set the ranges more finely. Control of the frequency of the ultrasonic wave to be transmitted is made not only in response to the depth of field of view but also in other setting such as in response to the position of the enlargingly displayed area of field of view, etc.

[0040] As described in detail above, the advantage of the present invention is that if the depth of field of view is set according to the position of diagnostic target region, an ultrasonic wave which frequency corresponds to the depth of field of view is transmitted, and therefore, information concerning the area surrounding the diagnostic target region is obtained, and if the depth of field of view is set shallow, an image of high resolution can be obtained.

[0041] Further, the advantage of the present invention is that an ultrasonic wave which frequency corresponds to the depth of field of view is transmitted and therefore, if the depth of field of view is set deep, the limit of visible depth becomes deep whereby it becomes easy to see the diagnostic image, and as a result, the accuracy of diagnosis is improved.

[0042] Further, the advantage of the present invention is that an ultrasonic wave which frequency corresponds to the position of enlargingly displayed area of field of view is transmitted, and therefore, if enlargingly displayed area of field of view is set shallow, an image of high resolution can be obtained.

[0043] Further, the advantage of the present invention is that an ultrasonic wave which frequency corresponds to the position of the enlargingly displayed area of field of view is transmitted and therefore, if the enlargingly displayed area of field of view is set deep, the limit of visible depth becomes deep, whereby it becomes easy to see the enlargingly displayed diagnostic image, and as a result, the accuracy of diagnosis is improved.

[0044] According to the present invention, the user can easily change the setting wherein the frequency of the ultrasonic wave to be transmitted from the ultrasonic transmitting/receiving means according to the field of view is automatically changed, and therefore, it is easy to compensate in response to the change of limit of visible depth.

Claims

1. An ultrasonic diagnostic apparatus comprising:

ultrasonic transmitting/receiving means for transmitting ultrasonic wave to a living body and receiving the reflected wave from the living body to convert the received wave into an electric signal;
control means for controlling the frequency of the ultrasonic wave to be transmitted from said ultrasonic transmitting/receiving means according to field of view; and,
display means for displaying diagnostic image on the basis of the electric signal from said ultrasonic transmitting/receiving means.

2. The ultrasonic diagnostic apparatus described in claim 1, wherein said control means controls the frequency of the ultrasonic wave to be transmitted from the ultrasonic transmitting/receiving means according to the depth of field of view.

3. The ultrasonic diagnostic apparatus described in claim 1 or 2, wherein said control means controls the frequency of the ultrasonic wave to be transmitted by the ultrasonic transmitting/receiving means according to the position of the enlargingly displayed field of view.

4. The ultrasonic diagnostic apparatus described in any preceding claim, further including a rewritable retention table for diagnostic condition data.

5. The ultrasonic diagnostic apparatus described in any preceding claim, wherein said ultrasonic transmitting/receiving means has an ultrasonic probe for transmitting ultrasonic waves of plural different frequencies, said control means includes a system controller for determining the frequency of the ultrasonic wave to be transmitted from said ultrasonic probe according to the field of view set by a user through an operation panel and said display means includes a display unit.

FIG. 1

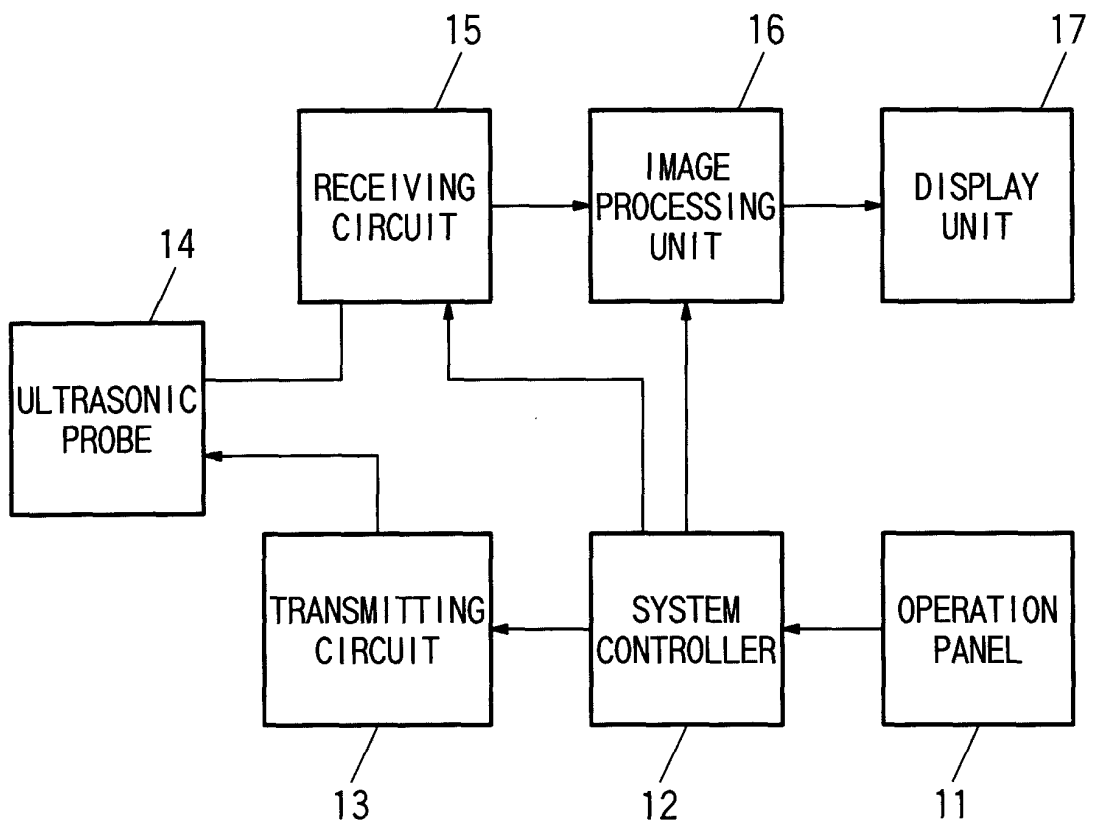

FIG. 2

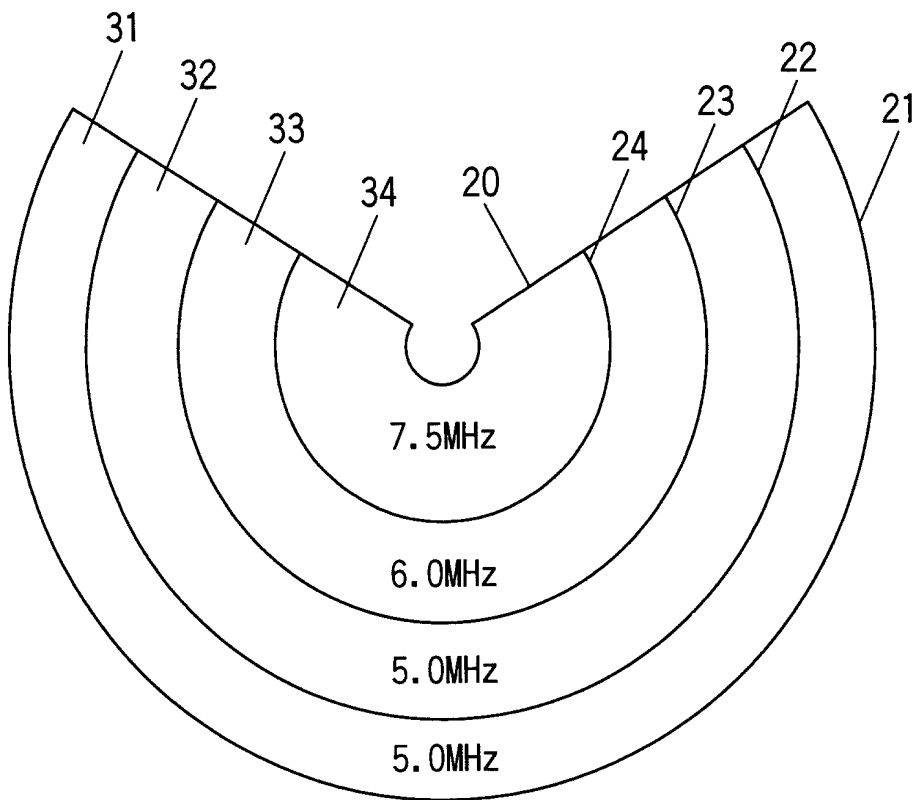

FIG. 3

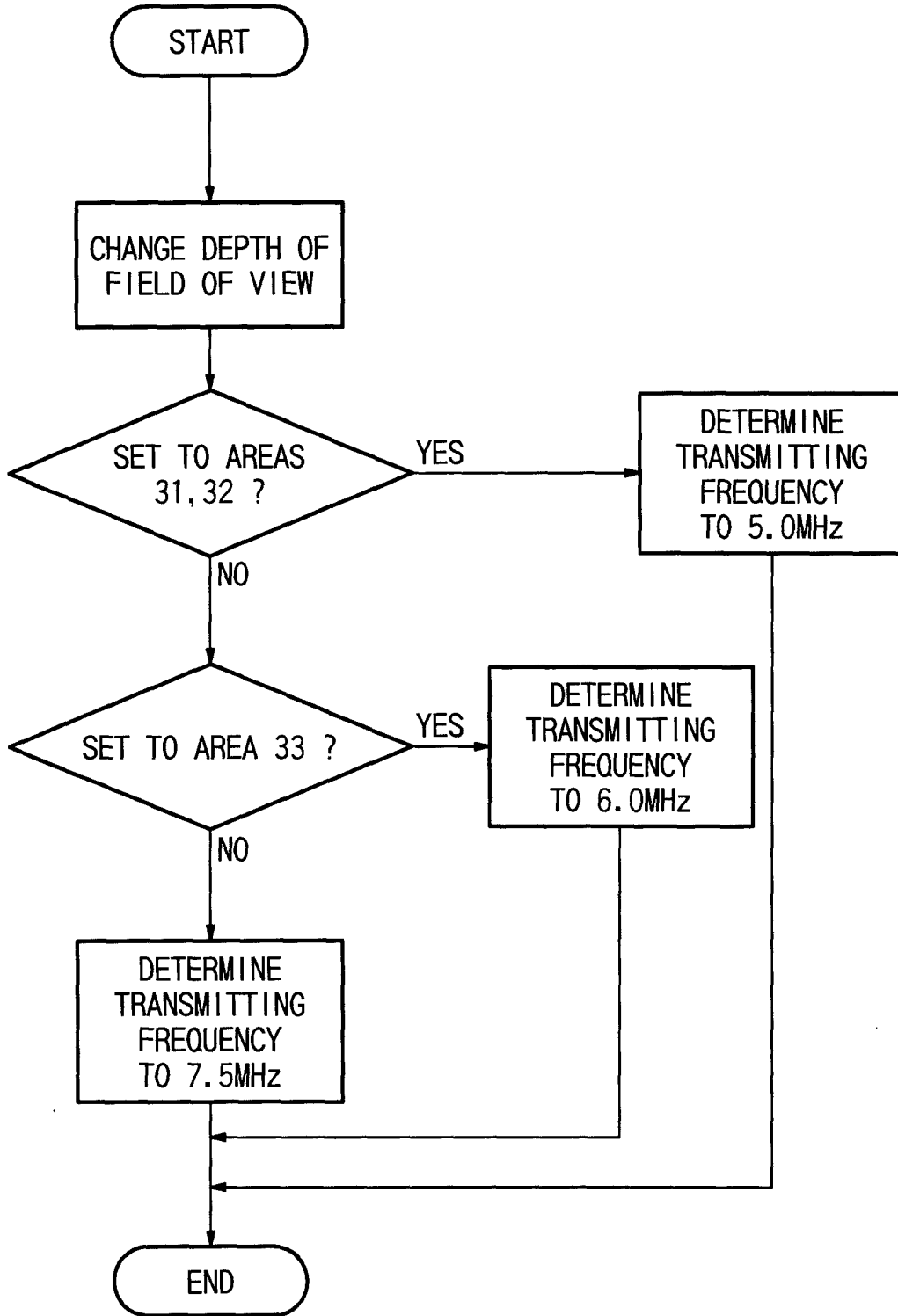
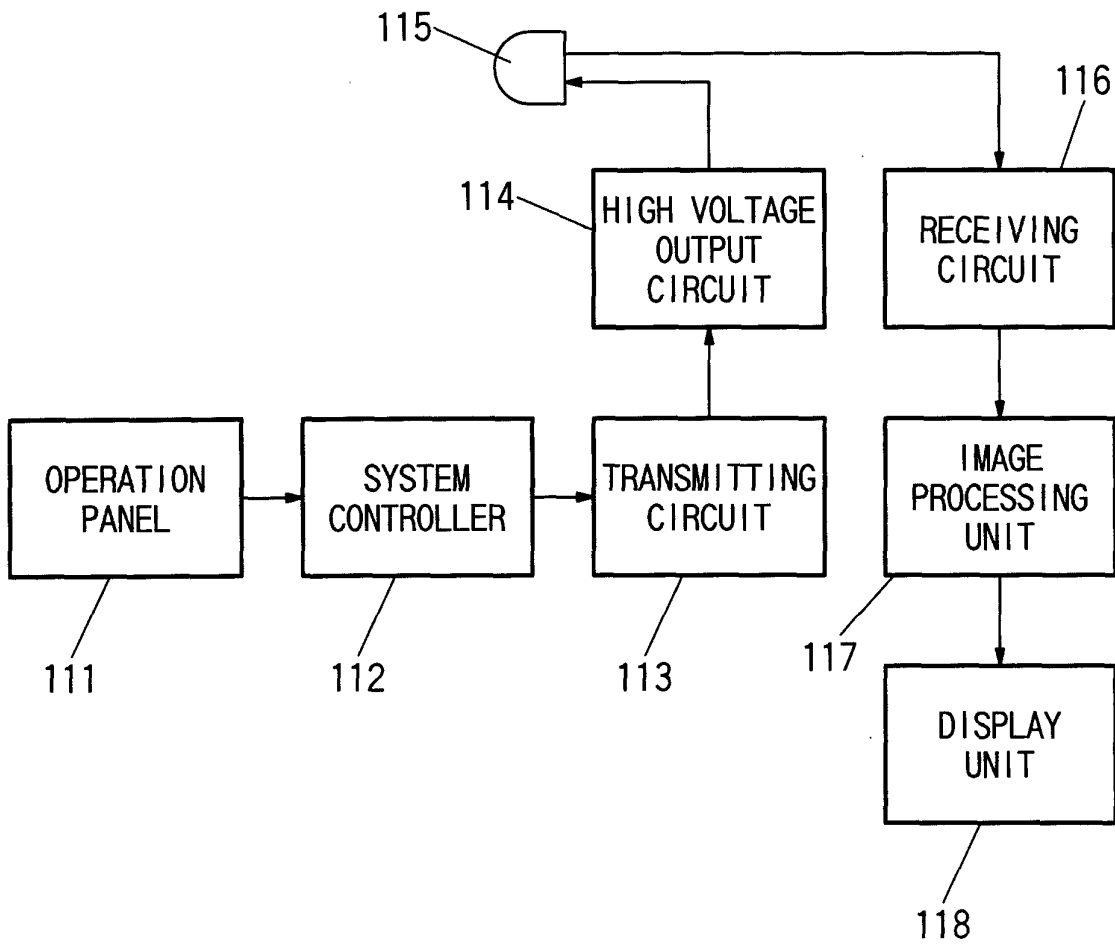

FIG. 5



专利名称(译)	断层超声诊断设备		
公开(公告)号	EP1138262A2	公开(公告)日	2001-10-04
申请号	EP2001302344	申请日	2001-03-14
申请(专利权)人(译)	松下电器产业有限公司.		
当前申请(专利权)人(译)	柯尼卡美能达, INC.		
[标]发明人	NAKAMURA MITSUYUKI KOSAKA NOBORU		
发明人	NAKAMURA, MITSUYUKI KOSAKA, NOBORU		
IPC分类号	A61B8/14 G01S7/52 G01S15/89 A61B8/13		
CPC分类号	G01S7/5206 A61B8/14 G01S15/895 G01S15/8952		
代理机构(译)	RACKHAM, STEPHEN NEIL		
优先权	2000087851 2000-03-28 JP		
其他公开文献	EP1138262A3 EP1138262B1		
外部链接	Espacenet		

摘要(译)

本发明的超声波诊断装置包括：操作面板11，通过该操作面板设定不同的诊断条件；系统控制器12，用于根据视场控制要发送的超声波的频率；发送电路13，用于发送超声波波形，用于接收来自超声波探头14的反射波以将反射波转换成电信号的接收电路15，用于对来自接收电路15的信号进行预定处理的图像处理单元16和用于接收电路15的显示单元17基于来自图像处理设备16的电信号显示断层图像。

