

(19) World Intellectual Property Organization
International Bureau



(43) International Publication Date
24 January 2002 (24.01.2002)

PCT

(10) International Publication Number
WO 02/05896 A1

- (51) International Patent Classification⁷: A61N 7/02, A61B 8/00
- (21) International Application Number: PCT/SE01/01625
- (22) International Filing Date: 16 July 2001 (16.07.2001)
- (25) Filing Language: Swedish
- (26) Publication Language: English
- (30) Priority Data:
0002677-3 17 July 2000 (17.07.2000) SE
- (71) Applicant (for all designated States except US): **DIAGNOS NAVIGATION AND TREATMENT SCANDINAVIA AB** [SE/SE]; Ole Römers väg 12, S-223 63 Lund (SE).
- (72) Inventor; and
- (75) Inventor/Applicant (for US only): **LIDGREN, Lars, Åke, Alvar** [SE/SE]; Örnvägen 35, S-227 31 Lund (SE).
- (74) Agents: **WAGNER, Heinz** et al.; H Wagner & Co AB, Norra Vallgatan 72, S-211 22 Malmö (SE).
- (81) Designated States (national): AL, AM, AT, AU, AZ, BA, BB, BG, BR, BY, CA, CH, CN, CU, CZ, DE, DE (utility model), DK, EE, ES, FI, GB, GE, GH, GM, HR, HU, ID, IL, IS, JP, KE, KG, KP, KR, KZ, LC, LK, LR, LS, LT, LU, LV, MD, MG, MK, MN, MW, MX, NO, NZ, PL, PT, RO, RU, SD, SE, SG, SI, SK, SL, TJ, TM, TR, TT, UA, UG, US, UZ, VN, YU, ZW.
- (84) Designated States (regional): ARIPO patent (GH, GM, KE, LS, MW, MZ, SD, SL, SZ, TZ, UG, ZW), Eurasian patent (AM, AZ, BY, KG, KZ, MD, RU, TJ, TM), European patent (AT, BE, CH, CY, DE, DK, ES, FI, FR, GB, GR, IE, IT, LU, MC, NL, PT, SE, TR), OAPI patent (BF, BJ, CF, CG, CI, CM, GA, GN, GW, ML, MR, NE, SN, TD, TG).
- Published:**
- with international search report
 - before the expiration of the time limit for amending the claims and to be republished in the event of receipt of amendments
- For two-letter codes and other abbreviations, refer to the "Guidance Notes on Codes and Abbreviations" appearing at the beginning of each regular issue of the PCT Gazette.

(54) Title: DEVICE FOR NON-INVASIVE ULTRASOUND TREATMENT OF DISC DISEASE

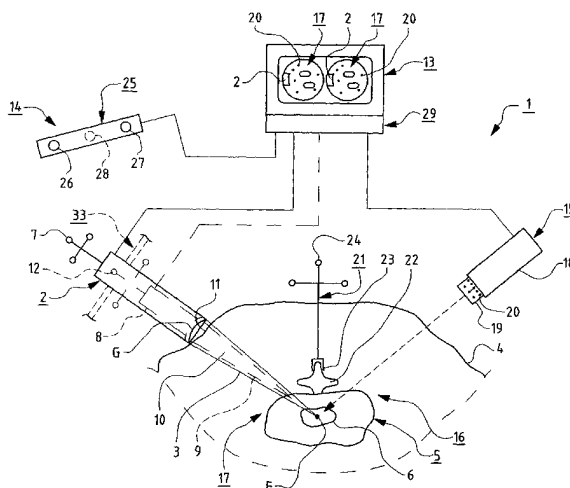

(57) Abstract: The present invention relates to a device for non-invasive ultrasound treatment of disc disease. This device comprises a therapeutic ultrasound transducer (2) which is provided for treatment of the disc (5), preferably nucleus pulposus (6), of a patient (4) by generating by means of said therapeutic ultrasound transducer (2) an ultrasonic field (3), the temperature focus (F) of which is located in the disc (5), preferably nucleus pulposus (6), for heating thereof. The therapeutic ultrasound transducer (2) is of a "phased array"-type and a diagnostic ultrasound transducer (8) is provided to determine the acoustic properties of the patient's (4) tissue (10). An optical navigating device (14) comprises at least one diagnostic camera (15) and at least one signal receiving and/or signal sending unit (16) which is adapted to send or transmit signals to and/or receive reflected or other signals from position transmitters (24, 7) on a reference device (21) and on the therapeutic ultrasound transducer (2). A computer (29) is provided with at least one computer program which is designed for calculations in connection with settings of the device.



WO 02/05896 A1

(19) World Intellectual Property Organization
International Bureau



(43) International Publication Date
24 January 2002 (24.01.2002)

PCT

(10) International Publication Number
WO 02/05896 A1

- (51) International Patent Classification⁷: A61N 7/02, A61B 8/00
- (21) International Application Number: PCT/SE01/01625
- (22) International Filing Date: 16 July 2001 (16.07.2001)
- (25) Filing Language: Swedish
- (26) Publication Language: English
- (30) Priority Data:
0002677-3 17 July 2000 (17.07.2000) SE
- (71) Applicant (for all designated States except US): DIAGNOS NAVIGATION AND TREATMENT SCANDINAVIA AB [SE/SE]; Ole Römers väg 12, S-223 63 Lund (SE).
- (72) Inventor; and
- (75) Inventor/Applicant (for US only): LIDGREN, Lars, Åke, Alvar [SE/SE]; Örnvägen 35, S-227 31 Lund (SE).
- (74) Agents: WAGNER, Heinz et al.; H Wagner & Co AB, Norra Vallgatan 72, S-211 22 Malmö (SE).
- (81) Designated States (national): AL, AM, AT, AU, AZ, BA, BB, BG, BR, BY, CA, CH, CN, CU, CZ, DE, DE (utility model), DK, EE, ES, FI, GB, GE, GH, GM, HR, HU, ID, IL, IS, JP, KE, KG, KP, KR, KZ, LC, LK, LR, LS, LT, LU, LV, MD, MG, MK, MN, MW, MX, NO, NZ, PL, PT, RO, RU, SD, SE, SG, SI, SK, SL, TJ, TM, TR, TT, UA, UG, US, UZ, VN, YU, ZW.
- (84) Designated States (regional): ARIPO patent (GH, GM, KE, LS, MW, MZ, SD, SL, SZ, TZ, UG, ZW), Eurasian patent (AM, AZ, BY, KG, KZ, MD, RU, TJ, TM), European patent (AT, BE, CH, CY, DE, DK, ES, FI, FR, GB, GR, IE, IT, LU, MC, NL, PT, SE, TR), OAPI patent (BF, BJ, CF, CG, CI, CM, GA, GN, GW, ML, MR, NE, SN, TD, TG).
- Published:**
— with international search report
— before the expiration of the time limit for amending the claims and to be republished in the event of receipt of amendments

For two-letter codes and other abbreviations, refer to the "Guidance Notes on Codes and Abbreviations" appearing at the beginning of each regular issue of the PCT Gazette.

(54) Title: DEVICE FOR NON-INVASIVE ULTRASOUND TREATMENT OF DISC DISEASE

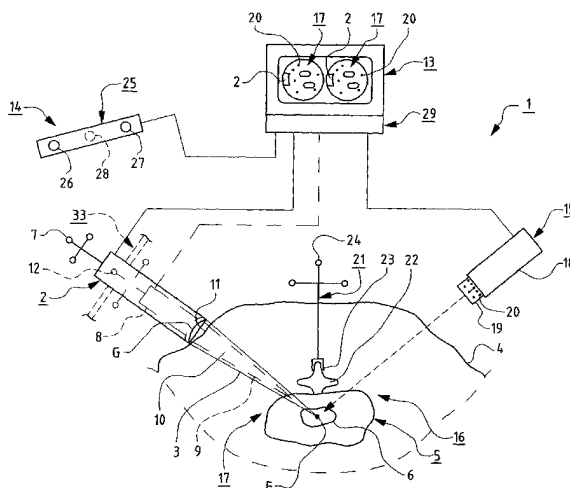

(57) Abstract: The present invention relates to a device for non-invasive ultrasound treatment of disc disease. This device comprises a therapeutic ultrasound transducer (2) which is provided for treatment of the disc (5), preferably nucleus pulposus (6), of a patient (4) by generating by means of said therapeutic ultrasound transducer (2) an ultrasonic field (3), the temperature focus (F) of which is located in the disc (5), preferably nucleus pulposus (6), for heating thereof. The therapeutic ultrasound transducer (2) is of a "phased array"-type and a diagnostic ultrasound transducer (8) is provided to determine the acoustic properties of the patient's (4) tissue (10). An optical navigating device (14) comprises at least one diagnostic camera (15) and at least one signal receiving and/or signal sending unit (25) which is adapted to send or transmit signals to and/or receive reflected or other signals from position transmitters (24, 7) on a reference device (21) and on the therapeutic ultrasound transducer (2). A computer (29) is provided with at least one computer program which is designed for calculations in connection with settings of the device.



WO 02/05896 A1

1.

Device for non-invasive ultrasound treatment of disc disease.

The present invention relates to a device for non-invasive ultrasound treatment of disc disease, wherein at least one therapeutic ultrasound transducer is provided for treatment of the disc, preferably nucleus pulposus, of a patient by generating by means of said therapeutic ultrasound transducer an ultrasonic field, the temperature focus of which is located in the disc, preferably nucleus pulposus, for heating thereof, and wherein the therapeutic ultrasound transducer is of a "phased-array"-type for being able to vary the distance between the transmitter element of the therapeutic ultrasound transducer and the temperature focus of its ultrasonic field.

The intervertebral disc consists of an outer fibrous tissue ring, anulus fibrosus, and an inner, more viscous part, nucleus pulposus. The disc functions as a shock absorber and if anulus fibrosus breaks, e.g. a small fissuring, disc matter may find its way out and cause a compression of nerve roots and induce an inflammatory reaction.

Prolapsed intervertebral discs have been treated surgically since the thirties by removal of the displaced disc matter and/or a part of the bulging disc. Later, the surgical treatment has developed towards less invasive operations and now, microscopes and percutaneous techniques are used for removing disc matter. An alternative method for surgical treatment is chemonucleolys, where the enzyme chymopapain is injected into nucleus pulposus, the central part of the disc. The enzyme polymerizes the long proteoglycan chains in nucleus pulposus with subsequent loss of the hygroscopicity. This reduces the volume and pressure in nucleus pulposus and the bulging part of the disc, which explains the pain relief patients with sciatica experience after chemonucleolys. The method has

2.

proven to give pain relief in 75 per cent of the cases and has a well documented cost efficiency. Unfortunately, the method has caused serious allergic reactions in about 1 per cent of the cases. Next step in the development could
5 be a non-invasive treatment or therapy of prolapsed intervertebral discs, which preferably should be painless, avoid the risk for infections and carried through ambulatory.

A method for thermotherapy and coagulation of tissue
10 involves use of focused ultrasound with high intensity. The ultrasound pass well through soft tissue and can be focused on remote spots within a surface of a few millimeters. The energy absorption in the tissue increases the temperature with a sharp temperature gradient such that
15 the boundaries of the treated volume are clearly limited without causing any damages on the surrounding tissue (US 5 291 890, US 5 501 655). Ultrasound treatment or therapy of prolapsed intervertebral discs is previously known (EP 0 872 262).

20 Heat treatment or thermotherapy of discs has proven successful in a method called IDET (US 6 073 051, US 6 007 570, US 5 980 504). The method has as its aim to insert a catheter into the disc by means of a cannula. Farthest out on the catheter there is a spool which is
25 heated by applying a radio frequency voltage thereon (US 5 785 705). The heat is increased to about 90°C in nucleus pulposus where the heating element of the catheter has been located and treatment or therapy is carried through for about 15 minutes.

30 Surgery with focused ultrasound has several advantages compared with other thermal techniques. In the first place, it is non-invasive, secondly, focus can be made movable and thirdly, the energy can be supplied in a few seconds. The limitation of ultrasound is its
35 absorption in bone and its poor penetration through gas-filled passages. Clinical applications of ultrasound surgery are today mostly used in ophtalmic surgery, uro-

3.

logy and oncology. The effect of ultrasound can be divided into thermal and non-thermal effects.

The thermal effects of ultrasound are caused by absorption of ultrasound in the tissue. This leads to a temperature increase which is dependent on the parameters of the ultrasound (frequency and intensity) and the acoustic properties of the tissue. The absorption of ultrasound in musculoskeletal tissues increases with the apatite and protein content, which means high absorption in bone, cartilage, tendons and ligaments. Water however, has a low ultrasound absorption capacity and can for this reason be used as an acoustic medium between the ultrasound transducer and the tissue. Higher absorption can be expected in anulus fibrosus (high collagen content) than in nucleus pulposus (high water content). This will lead to higher temperatures in the outer part of the intervertebral disc than in the central part. In order to avoid that the temperature in anulus fibrosus exceeds a detrimental level at the same time as the temperature in nucleus pulposus reaches a sufficient level, the ultrasound can be transmitted from several ultrasound sources. In this manner, the fields will overlap each other and increase the effect in nucleus pulposus at the same time as the intensity in the surrounding tissue including anulus fibrosus can be kept low.

The object of the present invention has been to facilitate, at the abovementioned devices, location of the temperature focus of the ultrasonic field of the ultrasound transducer on a desired point in the disc, preferably in nucleus pulposus. This is arrived at according to the invention by means of a device having the characterizing features of subsequent claim 1.

By means of the device defined in the claims, it is achieved that the temperature focus of the ultrasonic field of the therapeutic ultrasound transducer can be located and maintained on the desired point in the disc, preferably in nucleus pulposus.

4.

The invention will be further described below with reference to the accompanying drawings, in which

fig. 1 schematically illustrates a structural embodiment of the device according to the invention; and

5 fig. 2 schematically illustrates a calibrating device which may form part of a device according to fig. 1.

The treatment device 1 schematically illustrated in fig. 1 is adapted to generate, by means of one or more therapeutic ultrasound transducers 2 (so called therapeutic transducers), one or more ultrasonic fields 3, the temperature focus F of which is intended to be located in the intervertebral disc 5, preferably in nucleus pulposus 6, of the patient 4 for treatment thereof. In fig. 1, only one therapeutic ultrasound transducer 2 is illustrated, but there may be several transducers as in e.g. EP 0 872 262.

The therapeutic ultrasound transducer 2 comprises a plurality of, preferably three or more position transmitters 7 for determining its position.

20 In more detail, the therapeutic ultrasound transducer 2 is adapted to cause a local temperature increase in nucleus pulposus 6 so that enzymes such as collagenase present in the disc 5, are activated and cause decomposition of collagen and proteoglycans, which results in shrinking of nucleus pulposus 6 primarily because of less hygroscopicity. The therapeutic ultrasound transducer 2 can transmit its ultrasonic field 3 dorsolaterally from several different ports simultaneously. For being able to vary the focal distance of the therapeutic ultrasound transducer 2, i.e. the distance between its transmitter element G and the temperature focus F, said therapeutic ultrasound transducer 2 must be of the "phased array"-type, including several small piezoelectric elements. By excitation of these elements with different time delays, a focused ultrasonic field 3 is generated.

35 The treatment device 1 further comprises a diagnostic ultrasound transducer 8. This is adapted to generate

5.

an ultrasonic field 9 for determining the acoustic properties of the patient's tissue 10 between the area 11 on the patient for location of the therapeutic ultrasound transducer 2 during treatment and the disc 5, preferably nucleus pulposus 6, to be treated. This "time of flight"-measurement with the diagnostic ultrasound transducer 8 is carried through for determining the distance between said area 11 and nucleus pulposus 6 as well as the thickness of the tissue and of the different tissue layers.

10 The tissue 10 passed consists in said order of skin, fat, muscles and anulus fibrosus. This information is needed to correct differences in size and tissue configuration of various patients, since the attenuation of the ultrasound is different in different types of tissue.

15 The diagnostic ultrasound transducer 8 comprises a plurality of, preferably three or more position transmitters 12 for determining its position and it is provided to generate an image of said tissue 10 in a monitor 13.

20 The treatment device 1 also comprises an optical navigating device 14 to navigate the therapeutic ultrasound transducer 2 (US 5 772 594). This optical navigating device 14 comprises at least one diagnostic camera 15 which is adapted to produce at least one picture or image of the anatomic structure 17 of the treatment area 16 in 25 the monitor 13. The diagnostic camera may be an X-ray camera 18 taking two pictures of the anatomic structure 17 of the treatment area 16 from different directions with preferably a 90° intermediate angle and showing these in the monitor 13. At the optical navigating device 30 14, the X-ray camera 18 is used together with an optical analogue-digital-converter for obtaining a real time image or picture in the monitor 13 of the position and direction of the therapeutic ultrasound transducer 2 (US 6 021 343, US 5 834 759, US 5 383 454).

35 The X-ray camera 18 comprises a calibrating device 19 - e.g. a calibrating hood - which is located in front of the objective of the X-ray camera 18 and having mar-

6.

kers 20 the mutual distance of which is known. The markers 20 may be round and consist e.g. of tantalum.

The optical navigating device 14 further comprises a reference device 21 which is provided to be attached to
5 the spinous process 23 of a vertebra 22 or in a corresponding position such that it gets a determined or fixed position relative to the treatment area 16. The reference device 21 has several position transmitters 24, namely preferably at least three, and these may consist of tan-
10 talum.

Furthermore, the optical navigating device 14 comprises a signal receiving and/or signal sending unit 25. This includes a suitable number of signal receivers 26,
27 for receiving reflected or other signals from the posi-
15 tion transmitters 7, 12 and 24 of the therapeutic ultrasound transducer 2, the diagnostic ultrasound transducer 8 and the reference device 21 respectively. The signal receiving and/or signal sending unit 25 may eventually comprise one or more signal transmitters 28 for sending or
20 transmitting signals to said position transmitters 7, 12 and 24, which are provided to receive these signals.

The signals transmitted by the position transmitters 7, 12 and 24 may e.g. be in the form of infrared light and the signal receivers 26, 27 may in such case be re-
25 ceivers of infrared light.

The treating device 1 further comprises a computer 29 with at least one computer program or software which is designed to calculate a suitable setting of the transmitter element G of the therapeutic ultrasound transducer 2,
30 based on the acoustic properties determined by the diagnostic ultrasound transducer 8, such that the temperature focus F of the ultrasonic field 3 of the therapeutic ultrasound transducer 2 can be brought to appear in the disc 5, preferably in nucleus pulposus 6, to be treated.

35 Said program or software may alternatively, or in combination with said setting of the therapeutic ultrasound transducer 2, be provided to calculate the position

7.

of the temperature focus F of the ultrasonic field 3 of the therapeutic ultrasound transducer 2 relative to said therapeutic ultrasound transducer 2, based on said acoustic properties and the setting of the therapeutic ultrasound transducer 2 in view of its focusing properties, so that the therapeutic ultrasound transducer 2 by means of said optical navigating device 14 can be positioned such that said temperature focus F appears in the disc 5, preferably nucleus pulposus 6, to be treated.

10 The computer 29 may be provided with a program (software) which is designed to calculate the effect of the ultrasonic field 3 of the therapeutic ultrasound transducer 2 in its temperature focus F based on the acoustic properties determined by the diagnostic ultrasound transducer 8, such that the temperature increase in nucleus pulposus 6 caused by the therapeutic ultrasound transducer 2, can be determined.

In the treatment device 1 there may also be included a calibrating unit 30 for calibrating (a) the position of the temperature focus F of the therapeutic ultrasound transducer 2 relative to its transmitter element G, and (b) the heating effect in said temperature focus F generated by said therapeutic ultrasound transducer 2. The calibrating unit 30 has similar acoustic properties as human tissue and contains a plurality of thermoelements 31 by means of which the position and effect on said temperature focus F can be measured for calibration. The thermoelements 31 are connected to a schematically illustrated measure instrument 32.

30 Prior to treatment of the disc 5, preferably nucleus pulposus 6, the reference device 21 is located on the patient's 4 vertebra 22 and the therapeutic ultrasound transducer 2 as well as the diagnostic ultrasound transducer 8 are calibrated in the calibrating unit 30. Then, a tissue analysis is made by means of the diagnostic ultrasound transducer 8, which preferably is navigated by means of the optical navigating device 14 while its

8.

position transmitter 12 cooperate through signals with the signal receivers 26, 27. A tissue image generated by the diagnostic ultrasound transducer 8 can be produced on the monitor 13, and the values of the tissue measured with said diagnostic ultrasound transducer 8 are used for setting the focal distance and effect of the therapeutic ultrasound transducer 2.

Two X-ray pictures are taken of the patient's 4 anatomic structure 17 at the disc 5 and these X-ray pictures are shown on the monitor 13. On these X-ray pictures, the position of the position transmitters 24 of the reference device 21 relative to the disc 5 may then be determined by means of the markers 20 of the calibrating device 19.

During treatment of the disc 5, preferably nucleus pulposus 6, the therapeutic ultrasound transducer 2 is navigated by means of the signal receiving or signal sending unit 25, whereby the navigation is presented in the X-ray pictures or images on the monitor 13. This is accomplished while the position transmitters 7 of the therapeutic ultrasound transducer 2 cooperate through signals with the signal transmitters 26 of the signal receiving or signal sending unit 25. By means of said navigation, the therapeutic ultrasound transducer 2 can be positioned such that the temperature focus F of its ultrasonic field 3 will lie in the disc 5, preferably nucleus pulposus 6. The temperature in the temperature focus F preferably exceeds 45°C.

The treatment can be automatically interrupted if the patient 4 moves to an incorrect position relative to the therapeutic ultrasound transducer 2 or vice versa.

The invention is not limited to the embodiment described above, but may vary within the scope of the following claims. Thus, the treated disc 5 may e.g. be any disc in the body.

The diagnostic camera 15 may be a computerized tomography (CT) scanner which is provided to produce images of said anatomic structure 17 and these images can be

9.

processed in a computer program or software for obtaining a 3D-image in the monitor 13.

The therapeutic ultrasound transducer 2 may be provided to be positioned manually or be located on a positioning device 33 for positioning thereof relative to the disc 5 to be treated.

It should also be mentioned that the signal receiving or signal sending unit 25 of the optical navigating device 14 may be an X-ray device.

10.

Claims:

1. Device for non-invasive ultrasound treatment of disc disease,

wherein at least one therapeutic ultrasound transducer (2) is provided for treatment of the disc (5), preferably nucleus pulposus (6), of a patient (4) by generating by means of said therapeutic ultrasound transducer (2) an ultrasonic field (3), the temperature focus (F) of which is located in the disc (5), preferably nucleus pulposus (6), for heating thereof, and

10 wherein the therapeutic ultrasound transducer (2) is of a "phased array"-type for being able to vary the distance between the transmitter element (G) of the therapeutic ultrasound transducer (2) and the temperature focus (F) of its ultrasonic field (3),

15 characterized in

that a diagnostic ultrasound transducer (8) is provided to determine the acoustic properties of the patient's (4) tissue (10) between the area for location of the therapeutic ultrasound transducer (2) for the treatment and the disc (5), preferably nucleus pulposus (6), to be treated,

20 that an optical navigating device (14) comprises at least one diagnostic camera (15) which is adapted to produce at least one picture or image of the anatomic structure (17) of the treatment area (16) within which the disc (5), preferably nucleus pulposus, to be treated, is located,

25 that the optical navigating device (14) further comprises at least one signal receiving and/or signal sending unit (25) which is adapted to send or transmit signals to and/or receive reflected or other signals from position transmitters (24, 7) on

a) a reference device (21) which has a set position relative to the disc (5), preferably nucleus pulposus (6), and

11.

b) the therapeutic ultrasound transducer (2) such that the position thereof relative to said treatment area (16) can be determined, and

that a computer (29) is provided with at least one
5 program (software) which is designed to calculate a suitable setting of the transmitter element (G) of the therapeutic ultrasound transducer (2), based on the acoustic properties determined by the diagnostic ultrasound transducer (8), such that the temperature focus (F) of the ultrasonic field (3) of the therapeutic ultrasound transducer
10 (2) can be brought to appear in the disc (5), preferably in nucleus pulposus (6), to be treated, whereby said program (software) alternatively, or in combination with said setting of the therapeutic ultrasound transducer (2),
15 can be provided to calculate the position of the temperature focus (F) of the ultrasonic field (3) of the therapeutic ultrasound transducer (2) relative to said therapeutic ultrasound transducer (2), based on said acoustic properties and the setting of the therapeutic ultrasound
20 transducer (2) in view of its focusing properties, so that the therapeutic ultrasound transducer (2) by means of said optical navigating device (14) can be positioned such that said temperature focus (F) appears in the disc (5), preferably nucleus pulposus (6), to be treated.

25 2. Device according to claim 1, characterized in that the computer (29) is provided with at least one computer program (software) which is designed to calculate the setting of the therapeutic ultrasound transducer (2) in view of its focusing properties, based
30 on the acoustic properties determined by the diagnostic ultrasound transducer (8) and the position of the therapeutic ultrasound transducer (2) relative to the disc (5), preferably nucleus pulposus (6), to be treated, such that the temperature focus (F) of the ultrasonic field (3)
35 of the therapeutic ultrasound transducer (2) appears in the nucleus pulposus (6) to be treated.

12.

3. Device according to claim 1 or 2, c h a r a c -
t e r i z e d i n that the computer (29) is provided
with at least one computer program (software) which is de-
signed to calculate the heating effect of the ultrasonic
5 field (3) of the therapeutic ultrasound transducer (2)
in its temperature focus (F) based on the acoustic pro-
perties determined by the diagnostic ultrasound trans-
ducer (8).

4. Device according to any preceding claim, c h a -
10 r a c t e r i z e d i n that the diagnostic ultrasound
transducer (8) is provided to determine the thickness of
different layers of said tissue (10) for determining the
acoustic properties thereof.

5. Device according to any preceding claim, c h a -
15 r a c t e r i z e d i n that the diagnostic ultrasound
transducer (8) is provided to produce a picture or image
of said tissue (10).

6. Device according to any preceding claim, c h a -
r a c t e r i z e d i n that the diagnostic ultrasound
20 transducer (8) comprises position transmitters (12) which
cooperate with the signal receiving and signal sending
unit (25).

7. Device according to any preceding claim, c h a -
r a c t e r i z e d i n that the diagnostic ultrasound
25 transducer (8) and the therapeutic ultrasound transducer
(2) are the same unit.

8. Device according to any preceding claim, c h a -
r a c t e r i z e d i n that the diagnostic camera
(15) is an X-ray camera (18).

30 9. Device according to claim 8, c h a r a c t e r i -
z e d i n that the X-ray camera (18) comprises a cali-
brating device (19) with markers (20) which are adapted
to determine the position of the anatomic structure (17)
of the treatment area (16) displayed in a monitor (13).

35 10. Device according to claim 9, c h a r a c t e
r i z e d i n that the monitor (13) is provided to dis-
play two X-ray photographs of said anatomic structure (17)

13.

taken with the X-ray camera (18) from two different locations.

11. Device according to any of claims 1-7, characterized in that the diagnostic camera (15) is a computerized tomography (CT) scanner which is provided to produce images of the anatomic structure (17) at the patient's (4) disc (5), said images being processed in a computer program (software) for obtaining a 3D-image in a monitor (13).

12. Device according to any preceding claim, characterized in that the therapeutic ultrasound transducer (2) is provided to be positioned manually by means of calculated determination of the temperature focus (F) of the ultrasonic field (3) of said therapeutic ultrasound transducer (2) relative to the transmitter element (G) of the therapeutic ultrasound transducer (2).

13. Device according to any of claims 1-11, characterized in that the therapeutic ultrasound transducer (2) is provided on a positioning device (33) for positioning thereof relative to the disc (5), preferably nucleus pulposus (6), to be treated.

14. Device according to any preceding claim, characterized in that the signal receiving or signal sending unit (25) is provided to receive or send signals in the form of infrared light and that said position transmitters (7, 12, 24) are provided to send or receive signals in the form of infrared light.

15. Device according to any preceding claim, characterized in that the temperature in the temperature focus (F) of the therapeutic ultrasound transducer (2) exceeds 45°C.

16. Device according to any preceding claim, characterized in that a calibrating device (19) is provided for calibrating the effect emitted by the therapeutic ultrasound transducer (2) in the temperature focus (F) of said therapeutic ultrasound trans-

14.

ducer (2) and/or the position of said temperature focus (F) relative to the transmitter element (G) of the therapeutic ultrasound transducer (2).

17. Device according to any preceding claim, c h a -
5 r a c t e r i z e d i n that the reference device (21) is attached to a vertebra (22) in the patient's vertebral column, preferably to the spinous process (23) of said vertebra (22).

18. Device according to any preceding claim, c h a -
10 r a c t e r i z e d i n that the reference device (21) comprises position transmitters (24) consisting of metallic balls, preferably tantalum balls.

19. Device according to claim 18, c h a r a c t e -
r i z e d i n that the signal receiving or signal sen-
15 ding unit (25) of the optical navigating device (14) consists of at least one X-ray device.

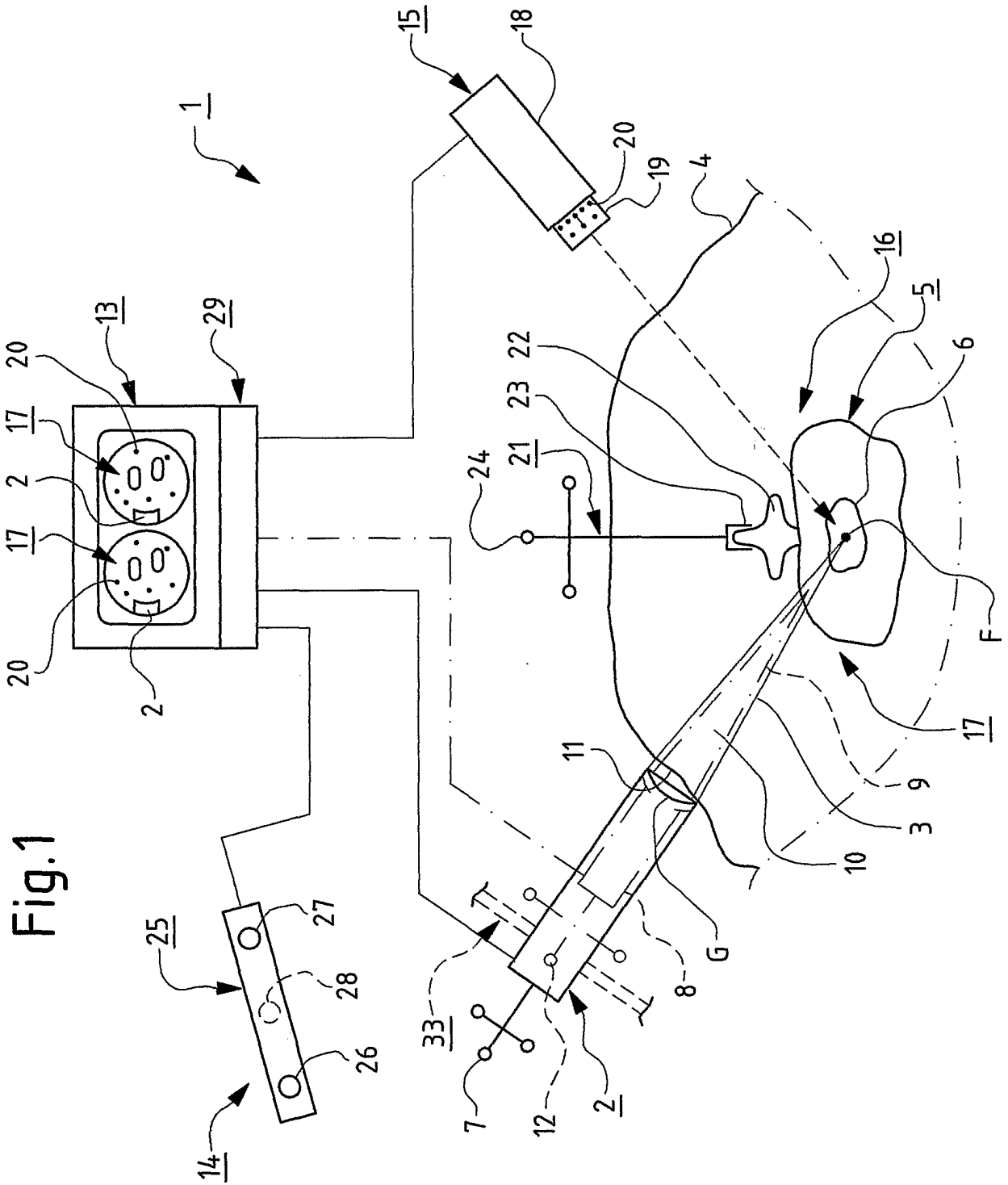
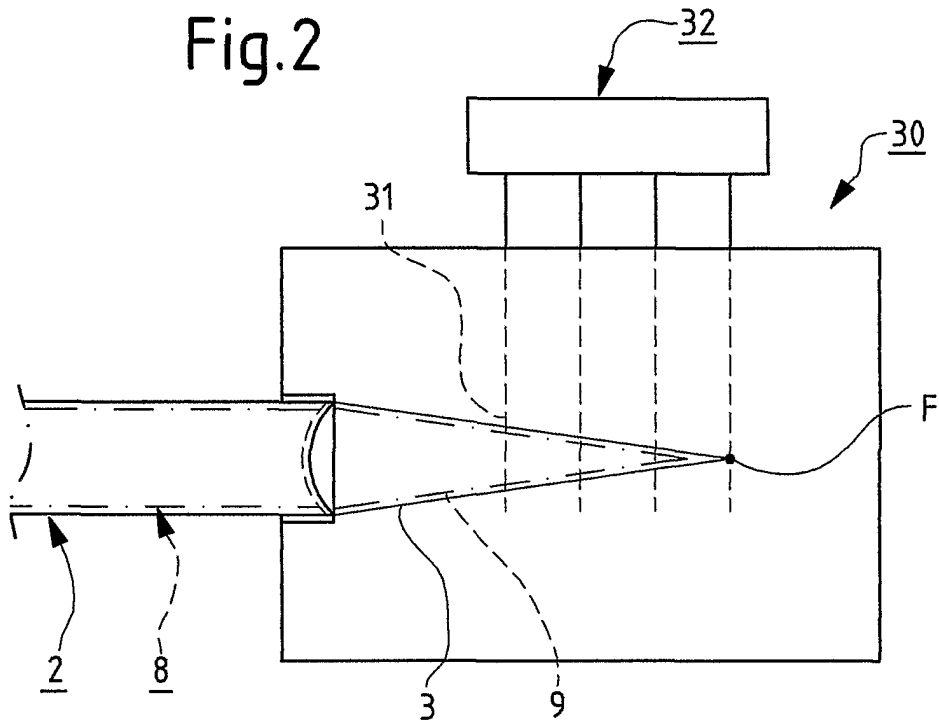

Fig.1

Fig.2



INTERNATIONAL SEARCH REPORT

International application No.

PCT/SE 01/01625

A. CLASSIFICATION OF SUBJECT MATTER

IPC7: A61N 7/02, A61B 8/00

According to International Patent Classification (IPC) or to both national classification and IPC

B. FIELDS SEARCHED

Minimum documentation searched (classification system followed by classification symbols)

IPC7: A61N, A61B

Documentation searched other than minimum documentation to the extent that such documents are included in the fields searched

SE,DK,FI,NO classes as above

Electronic data base consulted during the international search (name of data base and, where practicable, search terms used)

C. DOCUMENTS CONSIDERED TO BE RELEVANT

Category*	Citation of document, with indication, where appropriate, of the relevant passages	Relevant to claim No.
X	US 5526814 A (H.E. CLINE ET AL.), 18 June 1996 (18.06.96), page 2, line 25 - line 39, figure 1 --	1-19
A	US 5769790 A (R.D. WATKINS ET AL.), 23 June 1998 (23.06.98), figure 3, abstract --	1-19
A	EP 0872262 A2 (SCANDIMED INTERNATIONAL AB), 21 October 1998 (21.10.98), figure 1, abstract --	1-19
A	US 5443068 A (H.E. CLINE ET AL.), 22 August 1995 (22.08.95), figure 2, abstract --	1-19

 Further documents are listed in the continuation of Box C. See patent family annex.

* Special categories of cited documents:

"A" document defining the general state of the art which is not considered to be of particular relevance

"E" earlier application or patent but published on or after the international filing date

"L" document which may throw doubts on priority claim(s) or which is cited to establish the publication date of another citation or other special reason (as specified)

"O" document referring to an oral disclosure, use, exhibition or other means

"P" document published prior to the international filing date but later than the priority date claimed

"T" later document published after the international filing date or priority date and not in conflict with the application but cited to understand the principle or theory underlying the invention

"X" document of particular relevance: the claimed invention cannot be considered novel or cannot be considered to involve an inventive step when the document is taken alone

"Y" document of particular relevance: the claimed invention cannot be considered to involve an inventive step when the document is combined with one or more other such documents, such combination being obvious to a person skilled in the art

"&" document member of the same patent family

Date of the actual completion of the international search

26 November 2001

Date of mailing of the international search report

03 -12- 2001

Name and mailing address of the ISA/
Swedish Patent Office
Box 5055, S-102 42 STOCKHOLM
Facsimile No. +46 8 666 02 86

Authorized officer

Patrik Blidefalk/AE
Telephone No. +46 8 782 25 00

INTERNATIONAL SEARCH REPORT

International application No.

PCT/SE 01/01625

C (Continuation). DOCUMENTS CONSIDERED TO BE RELEVANT		
Category*	Citation of document, with indication, where appropriate, of the relevant passages	Relevant to claim No.
A	US 5150712 A (J. DORY), 29 Sept 1992 (29.09.92), figure 1, abstract -- -----	1-19

INTERNATIONAL SEARCH REPORT
Information on patent family members

International application No.
PCT/SE 01/01625

Patent document cited in search report			Publication date	Patent family member(s)	Publication date
US	5526814	A	18/06/96	NONE	
US	5769790	A	23/06/98	NONE	
EP	0872262	A2	21/10/98	AU 724143 B	14/09/00
				AU 4140497 A	19/03/98
				BR 9711372 A	17/08/99
				EE 9900102 A	15/10/99
				EP 0978090 A	09/02/00
				JP 10295718 A	10/11/98
				JP 2000517081 T	19/12/00
				SE 9701449 A	08/01/99
				US 6254553 B	03/07/01
US	5443068	A	22/08/95	NONE	

INTERNATIONAL SEARCH REPORT

Information on patent family members

International application No.

PCT/SE 01/01625

Patent document cited in search report	Publication date	Patent family member(s)	Publication date
US 5150712 A	29/09/92	BR 8406310 A	08/10/85
		DE 3466174 D	00/00/00
		EP 0148653 A,B	17/07/85
		SE 0148653 T3	
		FR 2556582 A,B	21/06/85
		FR 2621240 A	07/04/89
		HK 88789 A	17/11/89
		JP 1908287 C	24/02/95
		JP 4048457 B	06/08/92
		JP 60145131 A	31/07/85
		SG 104387 G	16/06/89
		US RE33590 E	21/05/91
		US 4617931 A,B	21/10/86
		US 5080101 A	14/01/92
		US 5080102 A	14/01/92
		US 5111822 A	12/05/92
		US 5143073 A	01/09/92
		US 5143074 A	01/09/92
		US 5150711 A	29/09/92
		US 5158070 A	27/10/92
		BR 8502055 A	31/12/85
		DE 3580702 D	00/00/00
		DE 3585691 D	00/00/00
		EP 0162735 A,B	27/11/85
		SE 0162735 T3	
		EP 0339693 A,B	02/11/89
		SE 0339693 T3	
		FR 2563725 A,B	08/11/85
		JP 1765452 C	11/06/93
		JP 4035181 B	10/06/92
		JP 60241436 A	30/11/85
		US 4658828 A	21/04/87
		US 5431621 A	11/07/95

专利名称(译)	用于椎间盘疾病的非侵入性超声治疗的装置		
公开(公告)号	EP1301243A1	公开(公告)日	2003-04-16
申请号	EP2001950182	申请日	2001-07-16
[标]申请(专利权)人(译)	乌尔特拉佐尼克斯DNT股份公司		
申请(专利权)人(译)	ULTRAZONIX DNT AB		
当前申请(专利权)人(译)	ULTRAZONIX DNT AB		
[标]发明人	LIDGREN LARS AKE ALVAR		
发明人	LIDGREN, LARS, AKE, ALVAR		
IPC分类号	A61B17/56 A61B6/00 A61B6/03 A61B6/12 A61B8/08 A61B18/00 A61B19/00 A61F7/00 A61N7/02 A61B8/00		
CPC分类号	A61N7/02 A61B8/0858 A61B34/20 A61B90/361 A61B2034/2055 A61B2034/2072 A61B2090/378		
优先权	0002677 2000-07-17 SE		
其他公开文献	EP1301243B1		
外部链接	Espacenet		

摘要(译)

本发明涉及一种用于椎间盘疾病的非侵入性超声治疗的装置。该装置包括治疗超声换能器(2)，其通过借助于所述治疗超声换能器(2)产生超声场来提供用于治疗患者(4)的椎间盘(5)，优选髓核(6)的治疗。(3)，其温度焦点(F)位于盘(5)，优选髓核(6)中，用于加热。治疗超声换能器(2)具有“相控阵”型，并且提供诊断超声换能器(8)以确定患者(4)组织(10)的声学特性。光学导航设备(14)包括至少一个诊断摄像机(15)和至少一个信号接收和/或信号发送单元(25)，其适于向位置发送或发送信号和/或从位置接收反射或其他信号。发射器(24,7)在参考设备(21)上和治疗超声换能器(2)上。计算机(29)具有至少一个计算机程序，该计算机程序被设计用于结合设备的设置进行计算。