

(19)



(11)

**EP 2 988 815 B1**

(12)

**EUROPEAN PATENT SPECIFICATION**

(45) Date of publication and mention of the grant of the patent:

**13.06.2018 Bulletin 2018/24**

(51) Int Cl.:

<b>A61M 25/01</b> (2006.01)	<b>A61M 25/10</b> (2013.01)
<b>A61J 15/00</b> (2006.01)	<b>A61B 8/08</b> (2006.01)
<b>A61B 8/00</b> (2006.01)	<b>A61B 17/00</b> (2006.01)
<b>A61B 17/34</b> (2006.01)	<b>A61B 90/00</b> (2016.01)

(21) Application number: **14788472.0**

(22) Date of filing: **22.04.2014**

(86) International application number:  
**PCT/US2014/034950**

(87) International publication number:  
**WO 2014/176236 (30.10.2014 Gazette 2014/44)**

(54) **COAPTATION ULTRASOUND DEVICES**

KOAPTATIONSULTRASCHALLVORRICHTUNGEN

DISPOSITIFS ULTRASONORES DE COAPTATION

(84) Designated Contracting States:

**AL AT BE BG CH CY CZ DE DK EE ES FI FR GB  
GR HR HU IE IS IT LI LT LU LV MC MK MT NL NO  
PL PT RO RS SE SI SK SM TR**

(74) Representative: **Cooley (UK) LLP**

**Dashwood  
69 Old Broad Street  
London EC2M 1QS (GB)**

(30) Priority: **22.04.2013 US 201361814516 P**

(43) Date of publication of application:  
**02.03.2016 Bulletin 2016/09**

(56) References cited:

<b>WO-A1-2010/129327</b>	<b>WO-A2-2010/036721</b>
<b>US-A1- 2010 094 116</b>	<b>US-A1- 2010 145 147</b>
<b>US-A1- 2012 197 062</b>	<b>US-A1- 2012 265 130</b>
<b>US-A1- 2013 072 792</b>	<b>US-A1- 2013 072 792</b>
<b>US-B2- 7 963 910</b>	

(73) Proprietor: **University of Maryland, Baltimore  
Baltimore MD 21201 (US)**

(72) Inventor: **TROPELLO, Steven, P.  
Baltimore, MD 21212 (US)**

**EP 2 988 815 B1**

Note: Within nine months of the publication of the mention of the grant of the European patent in the European Patent Bulletin, any person may give notice to the European Patent Office of opposition to that patent, in accordance with the Implementing Regulations. Notice of opposition shall not be deemed to have been filed until the opposition fee has been paid. (Art. 99(1) European Patent Convention).

## Description

### CROSS-REFERENCE TO RELATED APPLICATIONS

[0001] This application is based upon and claims priority from co-pending U.S. Provisional Patent Application Serial No. 61/814,516 entitled "Coaptation Ultrasound Devices and Methods of Use," filed with the United States Patent and Trademark Office on April 22, 2013, by the inventor herein.

### FIELD OF THE INVENTION

[0002] The present invention relates generally to placement of medical devices within a body in the medical field, and more particularly to methods and devices for ultrasound-guided placement of medical devices, such as catheters, conduits, carriers, electrodes, and the like into a patient's body.

### BACKGROUND OF THE PRIOR ART

[0003] A wide variety of medical procedures require placement of medical devices at various locations within a patient's body. For instance, certain procedures may require the placement of electrodes within a patient's spine, or attachment of electrodes to heart tissue, or the like. In other procedures, medical staff may wish to place temperature probes or heating wires at various locations within patient's body. Further, for cancer treatment, medical staff may wish to place radioactive seeds or deliver therapeutic medications deep within a patient's body, including directly into internal organs. In still other procedures, medical staff may wish to place catheters or other fluid or material-carrying conduits within the patient's body for delivery of medications or other materials, for carrying forceps, biopsy instruments or the like into the patient's body, for providing suctioning to various parts of a patient's body, and many other procedures involving the placement of medical devices within the patient's body. Procedures for placing such medical devices vary widely from application to application, but all carry the common aspect of presenting challenge to the medical staff in manipulating such medical devices within the patient's body to route them to their intended location and position them for their intended use at that location.

[0004] More particularly, often times medical procedures require manipulation of a catheter or other conduit through portions of the patient's body that are not easily accessible, and thus make maneuvering of the conduit to its intended location quite challenging. For instance, it may be medically necessary to place conduits within internal body cavities to provide for the drainage of unwanted fluid, to provide for the infusion of medications into internal organs or elsewhere in the body, to provide for direct nutritional supplementation to patients unable to orally consume adequate nutrition, and the like. The procedures for guiding such conduits to their intended

locations in a patient's body can be difficult to perform and can risk serious injury to the patient if not performed properly.

[0005] One such procedure that presents significant challenges is the placement of gastrostomy tubes for patients requiring direct nutritional supplementation into the stomach. Enteral feeding has been recommended when a patient has a functioning gut but is unable to eat for seven to fourteen days. When enteral feeding is anticipated to be required for longer than 30 days, a gastrostomy tube is preferred over a nasoenteric tube. The placement of gastrostomy tubes has become a frequently required procedure, with more than 215,000 being placed annually in the United States. The vast majority of such procedures are performed by consultants, such as gastroenterologists and interventional radiologists, as opposed to an emergency room doctor, an intensivist, or patient's primary physician. This is because those specialized consultant physicians have access to and have been trained on the expensive equipment that one must use to safely enter (i.e., cannulate) the stomach (i.e., gastrostomy). This expensive equipment includes endoscopes, fluoroscopes, and computed tomography (CT) scanners, all of which require specialized training and skill to operate properly.

[0006] The most common method for initial gastrostomy tube insertion is Percutaneous Endoscopic Gastrostomy ("PEG"), involving placing of a PEG tube into the patient's stomach. When performing a typical PEG process, a patient is placed in the supine position. A nasal or oral gastric tube is then introduced into the patient's stomach. Gastric fluid is removed using suction, such as through fenestrations at the distal end of the nasal or oral gastric tube. The stomach is then insufflated by way of the gastric tube or an endoscope. In one method, the endoscope has a light at the distal end. When illuminated, the practitioner is supposed to identify a suitable puncture site that is free from interposed organs and large vessels by noting where the light from the endoscope shines through the abdominal skin of the patient. An incision is then made at the identified target site, and a sheathed needle is then entered into the insufflated stomach. A guide wire is then introduced through the abdominal sheath and into the stomach. A snare or forceps located at the distal end of the endoscope is manipulated to capture the end of the guide wire. The endoscope is then extracted, pulling the guide wire along and ultimately causing the guide wire to exit through the mouth or nose. Applicant is aware of two preferred methods to complete the gastrostomy after the guide wire has been routed from the outside of the patient's abdomen, into their stomach, up their esophagus and out through their mouth or nose: the Ponsky-Gauderer (pull-(on) string) method (the "PG method"), and the Sacks-Vine (push-over -wire) method (the "SV method").

[0007] If the PG method is selected, the gastrostomy tube is tied to the end of the guide wire that has exited through the patient's nose or mouth. The abdominal end

of the guide wire is then pulled until the gastrostomy tube extends out from the hole in the abdomen, with the proximal end of the gastrostomy tube (having an enlarged end, or bumper, therein to prevent it from passing through the stomach wall and out of the patient's abdomen) remaining within and providing access to the interior of the patient's stomach. If the SV method is selected, the gastrostomy tube is placed over the guide wire and is pushed toward the stomach from the patient's mouth until it extends out from the abdominal hole. Again, the gastrostomy tube has a bumper to prevent the tube from passing entirely through the abdominal hole and causing the proximal end to remain in the stomach.

**[0008]** Alternatively, percutaneous gastrostomy placement can be performed using gastropexy methods. Gastropexy wires are inserted into the stomach via the angiocatheter and used to tether the stomach. Standard gastropexy techniques are then used to place the gastrostomy tube over a guide wire inserted only within the stomach.

**[0009]** Even with skilled consultant physicians handling these procedures, complications can occur including tube misplacement, inadvertent injury to surrounding tissues during placement, infections, tube clogging, and tube dislodgement during use. When such complications occur outside of the hospital, patients will often come to a hospital emergency room for help. However, as the PEG procedures require specialized skill in handling, emergency medicine physicians are often unable to perform the necessary procedures, and must instead call upon such specialist consultants, which adds to the overall expense and delay in treating the patient's issue, or risk of further complication or injury if someone lacking sufficient specialized skill attempts to address the issue.

**[0010]** Accordingly, there is a need in the art for a device and method that will allow for placement of a medical device into a patient's body, such as the performance of percutaneous gastrostomies, at the bedside and that will no longer require the expertise and equipment of specialist medical personnel, such as a gastroenterologist or other specialist. It would be advantageous to provide a method and device that would reduce the difficulties associated with installing medical devices inside of a patient's body, including medical instrument carriers, medication carriers, electrodes, probes, catheters and other conduits, and that would thereby reduce the risks of injury associated with previously known methods and devices.

**[0011]** US 2013/072792 relates to a balloon catheter assembly and includes a balloon at a distal end of a balloon catheter. The balloon is inflated with a fluid which has suspended therein a plurality of particles which may be microcapsules or pellets. The particles are echogenic and/or radiopaque, in the preferred embodiment to provide Rayleigh scattering of ultrasonic waves directed to the balloon. The balloon thus becomes visible under ultrasonic imaging and by use of an inflation fluid which can be of low viscosity and low toxicity.

**[0012]** WO 2010/129327 relates to a device for trache-

al intubation, which includes an endotracheal tube and a detachable inflatable sleeve fixed to an end of the tube, the inflatable sleeve having an array of magnetic field-responsive members disposed on an inner surface thereof. The device also includes a hand-held magnet which is used to attract the inflatable sleeve, thereby permitting manipulation of the position of the end of the tube. By direction of the hand-held magnet in the vicinity of the end of the tube, the tracheal intubation device permits placement of an endotracheal tube in the trachea without the necessity of direct visualization, hence providing a novel approach to resolving difficult intubations.

**[0013]** WO 2010/036721 relates to systems, methods, apparatus and devices for performing improved gynecologic and urologic procedures using a flowable distension media. The system and devices provide simplified use and reduced risk of adverse events. Patient benefit is achieved through improved outcomes, reduced pain, especially peri-procedural pain, and reduced recovery times. The various embodiments enable procedures to be performed outside the hospital setting, such as in a doctor's office or clinic.

**[0014]** US 2012/197062 relates to magnetic compression anastomosis carried out by placing cooperating magnets, one in the ileal conduit and one in the ureter, to lock together and form the anastomosis. The magnets may be placed to form a side-to-side anastomosis. At least one of the magnets can include radioactive material. Catheters may be used to place the magnets, and the catheters may have at least one deflatable or retractable tissue spacer.

## DESCRIPTION OF THE INVENTION

**[0015]** Disclosed herein is a system for manipulating an elongate medical member within a patient's body in accordance with claim 1. Advantageous features are defined in the dependent claims.

**[0016]** A kit for placing an elongate medical member within a patient's body is disclosed in claim 12. Advantageous features are defined in the dependent claims.

## BRIEF DESCRIPTION OF THE DRAWINGS

**[0017]** The numerous advantages of the present invention may be better understood by those skilled in the art by reference to the accompanying figures in which:

Figure 1 is a schematic view of a gastric tube and ultrasound probe adaptor used for gastrostomy procedures in accordance with certain aspects of an exemplary embodiment of the invention.

Figure 2 is a side view of the gastric tube of Figure 1.

Figure 3 is a close-up perspective exploded view of the distal end of the gastric tube of Figure 1.

Figure 4 is a close-up side view of the proximal end of the gastric tube of Figure 1.

Figure 5a is a schematic, cross-sectional top-down

view of the ultrasound probe adaptor of Figure 1.

Figure 5b is a perspective exploded view of an ultrasound probe adaptor in accordance with certain aspects of an embodiment of the invention.

Figure 6 is a side, cross-sectional view a patient's abdomen showing the positioning of an ultrasound probe adaptor in relation to the distal end of a gastric tube of Figure 1.

Figure 7 is a side perspective view of the positioning of an ultrasound probe adaptor in relation to the distal end of a gastric tube of Figure 1 in accordance with certain aspects of an exemplary embodiment of the invention.

Figure 8 is a flow diagram schematically representing an exemplary method not forming part of the invention of performing a gastrostomy in accordance with certain aspects of an embodiment of the invention.

Figure 9 is a schematic view of the placement of an ultrasound probe on a patient's body.

Figure 10 is a schematic view of the insertion of an angiocatheter into a patient's stomach in accordance with certain aspects of an embodiment of the invention.

Figure 11 is a schematic view of the capture of a guide wire within a patient's stomach in accordance with certain aspects of an embodiment of the invention.

Figure 12 is a schematic view of a guide wire placed within a patient's body in accordance with certain aspects of an embodiment of the invention.

Figure 13 shows a kit for placing a conduit within a patient's body in accordance with certain aspects of an embodiment of the invention.

#### BEST MODE(S) FOR CARRYING OUT THE INVENTION

**[0018]** The invention summarized above may be better understood by referring to the following description, claims, and accompanying drawings. This description of an embodiment, set out below to enable one to practice an implementation of the invention, is not intended to limit the preferred embodiment, but to serve as a particular example thereof. Those skilled in the art should appreciate that they may readily use the conception and specific embodiments disclosed as a basis for modifying or designing other methods and systems for carrying out the same purposes of the present invention. Those skilled in the art should also realize that such equivalent assemblies do not depart from the scope of the invention in its broadest form.

**[0019]** Figure 1 is a schematic view of a system in accordance with certain aspects of an exemplary embodiment of the invention. As shown in Figure 1, a gastric tube 110 is inserted into a patient's stomach 185, entering the patient through the head 181 (either through the patient's mouth or nose) and down through the patient's

esophagus 183, with the distal end (shown generally at 120) of gastric tube 110 ultimately being positioned within the patient's stomach. Also as shown in Figure 1, an ultrasound probe adaptor 200, which is configured to receive an ultrasound probe 595, is positionable on the outside of the patient's abdomen, and may be manually moved by a medical operator, along with ultrasound probe 595, to provide a visual image of the patient's abdomen using ultrasound methods well known to those of ordinary skill in the art.

**[0020]** Ultrasound probe adaptor 200 and the distal end of gastric tube 110 are configured to be magnetically attracted to each other. More particularly, both ultrasound probe adaptor 200 and the distal end of gastric tube 110 (or other elongate medical member, such as a catheter or conduit member as may be used throughout a patient's body and particularly other than in a patient's stomach) have magnetic members, as will be discussed in further detail below, that provide a sufficient attraction force between them so as to (i) cause the distal end of gastric tube 110 to come into contact with the internal tissue surface that is immediately adjacent the distal end of gastric tube 110 and closest to probe adaptor 200, and (ii) cause distal end of gastric tube 110 to move within the patient's body in response to movement of probe adaptor 200 and in a motion that corresponds to motion of probe adaptor 200 outside of the patient's body. While the particular magnetic members necessary to provide such magnetic attraction may vary, specific configurations of such magnetic members will be described by way of example in further detail below.

**[0021]** As shown in the detail view of Figure 2 and in accordance with certain features of an exemplary embodiment, gastric tube 110 comprises a lumen 122 extending from proximal end 112 of gastric tube 110 to distal end 120 of gastric tube 110. Proximal end 112 of gastric tube 110 may be provided additional functional elements, including a snare release 114, which provides a mechanism allowing the practitioner to control a snare positioned at distal end 132. The practitioner may push or pull snare release 114 to open or close the snare 132. Further, a syringe port 116 may be provided at proximal end 112 of gastric tube 110, providing a passageway to inflate a balloon 124 at the distal end 120 of gastric tube 110. Further, in some embodiments of the invention, one or more ports (not shown) may be provided at proximal end 112 of gastric tube 110 to connect external suction or insufflation devices. Such suction and insufflation ports may connect to one or more lumens that extend along the length of gastric tube 110.

**[0022]** With continued reference to Figure 2, distal end 120 of gastric tube 110 includes one or more balloons 124 that may be inflated by the practitioner, such as by injecting a fluid through syringe port 116 into balloon 124 via lumen 122. Inflation of the balloon 124 inside of the patient's stomach 185 will provide an echogenic space that may be observed by the practitioner when viewing an ultrasound image of the patient's stomach produced

by ultrasound probe 595, thus allowing the practitioner to confirm that the distal end 120 of gastric tube 110 is in its intended location within the patient's body.

**[0023]** Those skilled in the art will recognize that while a balloon 124 is shown as providing an echogenic space that may be observed via ultrasound, other echogenic configurations that will provide an image through an ultrasound procedure may likewise be provided on an elongate medical member without departing from the scope of the invention.

**[0024]** In order to configure distal end 120 so as to be magnetically attracted to ultrasound probe adaptor 200, distal end 120 is also preferably configured with one or more magnets 126. For example, magnets 126 may be positioned within and fixedly attached to the interior walls of balloon 124. Alternatively or additionally, magnets 126 may be located along the shaft of distal end 120 of gastric tube 110, and may be positioned internally along the distal end 120 of gastric tube 110, or externally (such as by clipping, by adhesive attachment, or otherwise) along the distal end 120 of gastric tube 110 or on the outside of balloon 124, without departing from the scope of the invention. Many different configurations of magnets 126 may be used in order to ensure proper alignment with and attraction to ultrasound adaptor 200.

**[0025]** Still further, distal end 120 of gastric tube 110 may be provided one or more tube fenestrations 140 that communicate with suction and/or insufflation ports at proximal end 112 of gastric tube 110, if such ports are provided. Likewise, snare 132 is located at distal end 120 of gastric tube 110, which snare 132 communicates with a snare operator, such as snare release 114, via snare line 130.

**[0026]** Figure 3 shows a close-up exploded view of distal end 120 of gastric tube 110 according to certain aspects of an exemplary embodiment of the invention. As shown in Figure 3, gastric tube 110 may be a generally cylindrical tube, and fenestrations 140 may be provided at the end of gastric tube 110 and aligned in axially-extending rows around the circumference of the end of gastric tube 110. Lumen 122 extends through gastric tube 110. Likewise, a flexible, inflatable balloon, which may be formed in varying shapes and sizes, is affixed to the end of gastric tube 110 and is in fluid communication with lumen 122 so that it may be inflated from the proximal end of gastric tube 110 with an echogenic medium, contrast agent or therapeutic agent. One or more magnets 126, such as by way of non-limiting example a neodymium block magnet having an approximate thickness of ¼" and an approximate length of 1 ½", is also situated in the distal end 120 of gastric tube 110, and may be positioned within balloon 124, within lumen 122, or bridging a portion of both balloon 124 and lumen 122. Further, magnet 126 may be rigidly affixed to balloon 124 and/or lumen 122, or may alternatively be positioned therein without fixation, so long as magnet 126's position will cause balloon 124 to be magnetically drawn toward ultrasound probe adaptor 200 when the probe adaptor is

placed against the patient's abdomen. In a most preferred configuration, magnets 126 are situated along opposite side edges of balloon 124 so as to allow them to align with magnets positioned on ultrasound adaptor 200, as further detailed below. Snare 132 and snare line 130 are not shown in Figure 3 for clarity, but those skilled in the art will recognize that such elements would be present and in a configuration as is well known in the art.

**[0027]** Figure 4 provides a close-up view of syringe port 116 located at the proximal end of gastric tube 110. In the illustrated embodiment, syringe port 116 is attached to a syringe 118. Syringe 118 may be filled with any type of fluid that is capable of expanding balloon 124 with an echogenic medium, contrast agent or therapeutic agent. In preferred embodiments, syringe 118 is filled with a non-toxic fluid that will enhance ultrasound imaging, such as by way of non-limiting example, water or saline. Gases may also be used to inflate balloon 124. While the illustrated embodiment shows syringe 118 being a removable element, in certain embodiments syringe 118 may be a permanent element, making the fluid transfer system between syringe 118 and balloon 124 a closed system.

**[0028]** Next, Figure 5a shows a schematic, cross-sectional top-down view of a coaptive ultrasound probe adaptor 200 in accordance with certain aspects of an embodiment of the invention. Adaptor 200 may be formed in a variety of different shapes to receive existing or yet-to-be-developed ultrasound probes. As used herein, "ultrasound probe" is intended to refer to any hand-held device configured to provide ultrasound imaging. Ultrasound probe adaptor 200 includes a magnetic source, and is physically configured so as to attach to an ultrasound probe 595. In the embodiment shown in Figure 5a, the magnetic source comprises an electromagnet having a power source 220, a variable resistor dial 240, and a coil 230, all contained within an external housing 210. Likewise, in order to attach to an ultrasound probe in the illustrated embodiment of Figure 5a, housing 210 is provided an ultrasound probe receiver, such as a central cavity 215, into which the scanning head of an ultrasound probe may be inserted. Alternatively, adaptor 200 may attach to an ultrasound probe 595 by clipping on to one or more edges of the probe, or in other ways as may be apparent to those of ordinary skill in the art. Likewise, while the illustrated embodiment of Figure 5a depicts a single electromagnetic configuration, other magnetic configurations and types may be used, such as ferromagnets positioned within housing 210, without departing from the scope of the invention. Likewise, variable resistor dial 240 or other adjustment devices may be used to increase or decrease the magnetic force of coil 230, in static or alternating frequency patterns, or alternatively no adjustment device may be provided, again without departing from the scope of the invention.

**[0029]** Figure 5b shows a close-up exploded view of a coaptive ultrasound probe adaptor 200, along with an ultrasound probe 595, according to certain aspects of a

particularly preferred embodiment of the invention. As shown in Figure 5b, ultrasound probe adaptor 200 includes base 210 having central cavity or opening 215 centrally located in the base 210 and extending through the entire thickness of base 210, such that ultrasound probe 595 may be placed in opening 215 and in contact with a patient's skin on which ultrasound probe adaptor 200 is positioned. With regard to an aspect of a particularly preferred embodiment of the invention, opening 215 is sized having a width dimension that is less than the width of balloon 124 on gastric tube 110, such that the sides of the balloon 124 extend past the long side edges of opening 215 when balloon 124 is magnetically attracted to ultrasound probe adaptor 200. Further, magnet receiving slots 217 are positioned at opposing sides of opening 215, and are each configured to removably receive a magnet 245a and 245b therein. Preferably, the magnets 245a and 245b are situated in opposite orientations from one another within their respective slots in ultrasound probe adaptor 200. As a result, the practitioner is assured that ultrasound probe adaptor 200 will magnetically attract a balloon 124, regardless of the orientation of the balloon 124 within the patient's body (i.e., regardless of which magnet pole is facing towards ultrasound probe adaptor 200). In one embodiment, ultrasound probe adaptor 200 is configured to position magnets 245a and 245b a distance away from one another that approximately matches the distance between magnets 126 positioned in balloon 124 so as to provide for alignment of the long axes of balloon 124 and ultrasound probe adaptor 200 when the two are magnetically attracted to one another. A first cover plate 247a may cover the magnet receiving slot 217 that receives magnet 245a, and a second cover plate 247b may cover the magnet receiving slot 217 that receives magnet 245b. Each such cover plate 247a and 247b is preferably removably held over its designated receiving slot 217 with removable connectors, such as threaded bolts 248 that extend into nuts 249 that in turn are held within base 110. As cover plates 247a and 247b are removable, and as magnets 245a and 245b are removable from slots 217, magnets of varying strength may be positioned within slots 217 so as to vary the amount of magnetic attraction that will be realized between ultrasound probe adaptor 200 and balloon 124, which may be necessary for varying medical procedures and varying patient physiology (i.e., with larger tissue planes between the ultrasound probe adaptor 200 and balloon 124 requiring larger magnetic attraction and in some cases repulsion).

**[0030]** Next, Figure 6 shows a cross-sectional view and Figure 7 a perspective view of the coaptive ultrasound probe adaptor 200 interacting with balloon 124 through a tissue plane. More particularly, the distal end 120 of gastric tube 110 having balloon 124 is shown in Figure 6 positioned inside of a patient's stomach, with ultrasound probe adaptor 200 positioned outside of the patient's body and in contact with the skin of the patient's abdomen. In the illustrated embodiment, ultrasound

probe adaptor 200 is positioned directly against the patient's skin 393, and the magnetic forces that attract balloon 124 to ultrasound probe adaptor 200 extend through the patient's skin 393, through the subcutaneous tissue 391, and through the stomach wall 395 (such tissue planes being hidden in Figure 7 for clarity). Magnetic members in each of ultrasound probe adaptor 200 and balloon 124, such as magnets 126, cause balloon 124 to come into contact with stomach wall 395 and to push stomach wall 395 against the subcutaneous tissue 391 of the patient's abdomen (defined as coaptation), thus easing access to balloon 124 with a needle, cannula, or other device as described in greater detail below. Moreover, as best seen in Figure 7, the position of magnets 126 in balloon 124 and of magnets 245a and 245b in ultrasound probe adaptor 200 may cause the balloon 124 and adaptor 200 to align their long axes with one another, and allow coordinated movement between the two.

**[0031]** Figure 8 is a flow diagram that depicts one method of performing a gastrostomy using the system of the present invention. Although steps are depicted in Figure 8 as integral steps in a particular order for purposes of illustration, in other embodiments, one or more steps, or portions thereof, are performed in a different order, or overlapping in time, in series or in parallel, or are omitted, or one or more additional steps are added, or the method is changed in some combination of ways. Some of the steps are illustrated in Figures 9 through 12. Moreover, while such method steps are specifically recited as corresponding to the performance of a gastrostomy, such gastrostomy process is referenced as exemplary only, and those of ordinary skill in the art will recognize that such method may be readily modified for many other procedures benefitting from remote, magnetic manipulation of an elongate medical member under ultrasound guidance using the general coaptive ultrasound methods shown in Figure 8 without departing from the scope of the invention.

**[0032]** First, in step 802, a gastric tube 110 configured as above is inserted through a patient's nose or mouth until the distal end 120 of the gastric tube 110 is positioned inside of the patient's stomach. Existing stomach contents are extracted, for example by applying suction through fenestrations 140 in the gastric tube 110. Next, the stomach is insufflated, for example by using both the same or different channels and fenestrations in the gastric tube 110. Syringe 118 is filled with non-toxic fluid. In steps 803 and 804, ultrasound probe 595 and adaptor 200 are placed on the patient's abdomen 590 (as shown in Figure 9). If the ultrasound probe adaptor is provided an electromagnet, it is activated at this time. As a result of the magnetic attraction between the ultrasound probe adaptor 200 and the distal end of gastric tube 120, the two components will align with one another along their long axes. Next, a suitable entry point is identified in step 805. Ultrasound probe 595 is used to ultrasonically image the patient's internal abdomen to detect any interposed organs or large vessels positioned between the ultra-

sound probe adaptor 200 and the balloon 124.

**[0033]** In the event that ultrasound probe adaptor 200 is provided an electromagnet assembly, the strength of the magnet may be adjusted using the variable resistor dial 240. Likewise, if ferromagnets are positioned in ultrasound probe adaptor 200, the strength of the magnetic force generated by ultrasound probe adaptor 200 may be modified by simply changing the magnets 245a and 245b in adaptor 200. In some cases, it may be necessary to reduce the magnetic attraction to allow for coordinated movement of the devices until a suitable entry point is identified. In other instances, it may be necessary to increase the magnetic attraction to account for excessive subcutaneous tissue. In any case, once a proper entry point is identified, the depth of the subcutaneous tissue may be measured to give the practitioner a reference point before making an incision.

**[0034]** Next, in step 806, and as shown in Figure 10, an inner needle 583 and angiocatheter 580 are inserted into the patient's stomach through the abdomen, preferably through opening 215 in adaptor 200. Inner needle 583 is then removed in step 807, and in step 808 (and as shown in Figure 11), guide wire 582 is introduced through angiocatheter 580. Once the distal end 587 of guide wire 582 is fed through snare 132, snare 132 is closed and the balloon 124 is deflated in step 809. Next, gastric tube 110 is removed from the patient in step 810, and snare 132 is released in step 811 when the gastric tube is completely removed. Figure 12 shows the final result of the method, in which guide wire 582 extends from the patient's stomach 185, through the esophagus 183, and out through the patient's head 181. The proximal end 589 terminates outside of the patient's stomach. The distal end 587 terminates outside of the patient's nose or mouth. Once guide wire 582 is in place, the feeding tube may be inserted at step 812 using either the Ponsky-Gauderer method or the Sacks-Vine method, as described above.

**[0035]** In another embodiment, the devices of the present invention are used to introduce a percutaneous gastrostomy tube into a patient using gastropexy methods. In this method, steps 802 through 807 remain the same. However, after the inner needle is removed, one or more gastropexy anchors are inserted into the patient's stomach. Once the one or more anchors are fixated, standard gastrostomy methods follow using a guide wire placed only within the stomach.

**[0036]** Figure 13 shows a kit for placing an elongate medical member, such as a conduit, within a patient's body in accordance with certain aspects of an embodiment of the invention. As shown in Figure 13, a kit preferably includes at least an ultrasound probe adaptor 200 configured as described above, a conduit 110, a syringe 118 for connection to a proximal end of conduit 110, a plurality of inflatable balloons 124 for connection to the distal end of conduit 110, and at least one magnet 126 sized for insertion into each of balloons 124. Preferably, more than one magnet 126 is provided, with the magnets

preferably having differing magnetic strengths that a practitioner may select for a particular circumstance (e.g., for tissue planes of varying thickness). Also, while not shown in Figure 13, additional elements could be provided with such a kit, including items such as feeding tubes or other supply or fluid drainage conduits, guide wires, dilators, and the like, all without departing from the scope of the instant invention.

**[0037]** In the foregoing specification, the invention has been described with reference to specific embodiments thereof. It will, however, be evident that various modifications and changes may be made thereto without departing from the broader scope of the invention. The specification and drawings are, accordingly, to be regarded in an illustrative rather than a restrictive sense. Throughout this specification and the claims, unless the context requires otherwise, the word "comprise" and its variations, such as "comprises" and "comprising," will be understood to imply the inclusion of a stated item, element or step or group of items, elements or steps but not the exclusion of any other item, element or step or group of items, elements or steps. Furthermore, the indefinite article "a" or "an" is meant to indicate one or more of the item, element or step modified by the article.

**[0038]** Having now fully set forth the preferred embodiments and certain modifications of the concepts underlying the present invention, various other embodiments as well as certain variations and modifications of the embodiments herein shown and described will obviously occur to those skilled in the art upon becoming familiar with said underlying concepts. It should be understood, therefore, that the invention may be practiced otherwise than as specifically set forth herein.

## INDUSTRIAL APPLICABILITY

**[0039]** The present invention is applicable to devices and methods for placing medical devices into and manipulating such medical devices within patients, particularly through ultrasound-guided placement and manipulation. The devices can be made in industry and practiced in the medical device field.

## Claims

1. A system for manipulating an elongate medical member within a patient's body, comprising:

an ultrasound probe adaptor (200) having an ultrasound probe therein; and  
 an elongate medical member having a distal end (120) and a proximal end (112), said distal end (120) of said elongate medical member further comprising an echo genie head;  
 wherein each of said ultrasound probe adaptor (200) and said distal end (120) of said elongate medical member are configured for magnetic at-

- traction toward one another with a magnetic force that is sufficient to allow coordinated movement between said ultrasound probe adaptor (200) and said echogenic head when said ultrasound probe adaptor (200) and said echogenic head are positioned on opposite sides of at least one tissue surface on a patient's body.
2. The system of claim 1, said ultrasound probe adaptor (200) further comprising at least a first magnetic member positioned adjacent said ultrasound probe.
  3. The system of claim 2, wherein said first magnetic member is removably positioned within said ultrasound probe adaptor (200).
  4. The system of claim 2, said elongate medical member further comprising at least a second magnetic member (126) positioned within said distal end (120) of said elongate medical member.
  5. The system of claim 4, wherein said second magnetic member (126) is positioned inside of said echogenic head.
  6. The system of claim 5, wherein said echogenic head further comprises a balloon (124).
  7. The system of claim 6, wherein said first magnetic member is positioned on a first side of said ultrasound probe, and said second magnetic member is positioned on a first side of said balloon (124), said system further comprising:
 

a third magnetic member positioned on a second side of said ultrasound probe opposite said first magnetic member; and

a fourth magnetic member positioned on a second side of said balloon (124) opposite said second magnetic member.
  8. The system of claim 7, wherein said first and third magnetic members are spaced apart from one another by a distance that is equal to a distance by which said second and fourth magnetic members are spaced apart from one another.
  9. The system of claim 4, wherein said first magnetic member and said second magnetic member have magnetic fields that are oriented so as to attract said distal end (120) of said elongate medical member towards a bottom surface of said adaptor.
  10. The system of claim 1, said elongate medical member further comprising a conduit having a snare (132) movably mounted therein, a snare operator adjacent the proximal end (112) of said conduit, and a snare closure section at the distal end (120) of said conduit.
  11. The system of claim 10, wherein said closure section of said snare (132) is positioned on an interior of said echogenic head.
  12. A kit for placing an elongate medical member within a patient's body, comprising:
 

the system of claim 1; and

a plurality of echogenic heads configured for attachment to said distal end (120) of said elongate medical member.
  13. The kit of claim 12, said ultrasound probe adaptor (200) further comprising at least a first magnetic member positioned adjacent said ultrasound probe.
  14. The kit of claim 13, wherein said first magnetic member is removably positioned within said ultrasound probe adaptor (200).
  15. The kit of claim 13, further comprising at least a second magnetic member sized to be inserted within each of said echogenic heads.
  16. The kit of claim 15, wherein said first magnetic member is positioned on a first side of said ultrasound probe adaptor (200), said kit further comprising:
 

a third magnetic member (126) positioned on a second side of said ultrasound probe adaptor (200) opposite said first magnetic member; and

a fourth magnetic member sized to be inserted within each of said echogenic heads.
  17. The kit of claim 12, further comprising a syringe (118) configured for attachment to said proximal end (112) of said elongate medical member.
  18. The kit of claim 12, wherein said elongate medical member further comprises a conduit.
  19. The kit of claim 12, wherein said echogenic heads further comprise balloons (124).

#### Patentansprüche

1. System für die Manipulation eines länglichen medizinischen Elements innerhalb des Körpers eines Patienten, das Folgendes umfasst:
 

einen Ultraschallsondenadapter (200) der eine Ultraschallsonde darin aufweist; und

ein längliches medizinisches Element, das ein distales Ende (120) und ein proximales Ende (112) aufweist, wobei das distale Ende (120) des länglichen medizinischen Elements weiter einen echogenen Kopf umfasst;

- wobei jeder des Ultraschallsondenadapters (200) und des distalen Endes (120) des länglichen medizinischen Elements zur magnetischen Anziehung zueinander mit einer Magnetkraft konfiguriert ist, die ausreicht, um eine koordinierte Bewegung zwischen dem Ultraschallsondenadapter (200) und dem echogenen Kopf zu ermöglichen, wenn der Ultraschallsondenadapter (200) und der echogene Kopf an gegenüberliegenden Seiten von mindestens einer Gewebeoberfläche an dem Körper eines Patienten positioniert sind.
2. System nach Anspruch 1, wobei der Ultraschallsondenadapter (200) weiter mindestens ein erstes magnetisches Element umfasst, das benachbart zu der Ultraschallsonde positioniert ist.
  3. System nach Anspruch 2, wobei das erste magnetische Element innerhalb des Ultraschallsondenadapters (200) entfernt positioniert ist.
  4. System nach Anspruch 2, wobei das längliche medizinische Element weiter mindestens ein zweites magnetisches Element (126) umfasst, das innerhalb des distalen Endes (120) des länglichen medizinischen Elements positioniert ist.
  5. System nach Anspruch 4, wobei das zweite magnetische Element (126) innerhalb des echogenen Kopfes positioniert ist.
  6. System nach Anspruch 5, wobei der echogene Kopf weiter einen Ballon (124) umfasst.
  7. System nach Anspruch 6, wobei das erste magnetische Element an einer ersten Seite der Ultraschallsonde positioniert ist und das zweite magnetische Element an einer ersten Seite des Ballons (124) positioniert ist, das System weiter Folgendes umfasst:
    - ein drittes magnetisches Element, das an einer zweiten Seite der Ultraschallsonde gegenüber dem ersten magnetischen Element positioniert ist; und
    - ein viertes magnetisches Element, das an einer zweiten Seite des Ballons (124) gegenüber dem zweiten magnetischen Element positioniert ist.
  8. System nach Anspruch 7, wobei das erste und dritte magnetische Element voneinander durch einen Abstand beabstandet sind, der gleich einem Abstand ist, durch den das zweite und vierte magnetische Element voneinander beabstandet sind.
  9. System nach Anspruch 4, wobei das erste magnetische Element und das zweite magnetische Element Magnetfelder aufweisen, die derart ausgerichtet sind, dass das distale Ende (120) des länglichen medizinischen Elements zu einer unteren Oberfläche des Adapters angezogen wird.
  10. System nach Anspruch 1, wobei das längliche medizinische Element weiter Folgendes umfasst: eine Leitung, die eine Schlinge (132) aufweist, die darin beweglich angebracht ist, einen Schlingenbediener benachbart zum proximalen Ende (112) der Leitung und einen Schlingenschließabschnitt an dem distalen Ende (120) der Leitung.
  11. System nach Anspruch 10, wobei der Schließabschnitt der Schlinge (132) an einem Inneren des echogenen Kopfes positioniert ist.
  12. Kit für die Positionierung eines länglichen medizinischen Elements innerhalb des Körpers eines Patienten, der Folgendes umfasst:
    - das System nach Anspruch 1; und
    - eine Vielzahl von echogenen Köpfen, die zur Anbringung an das distale Ende (120) des länglichen medizinischen Elements konfiguriert sind.
  13. Kit nach Anspruch 12, wobei der Ultraschallsondenadapter (200) weiter mindestens ein erstes magnetisches Element umfasst, das benachbart zu der Ultraschallsonde positioniert ist.
  14. Kit nach Anspruch 13, wobei das erste magnetische Element innerhalb des Ultraschallsondenadapters (200) entfernt positioniert ist.
  15. Kit nach Anspruch 13, der weiter mindestens ein zweites magnetisches Element umfasst, das zur Einführung in jeden der echogenen Köpfe dimensioniert ist.
  16. Kit nach Anspruch 15, wobei das erste magnetische Element auf einer ersten Seite des Ultraschallsondenadapters (200) positioniert ist, der Kit weiter Folgendes umfasst:
    - ein drittes magnetisches Element (126), das an einer zweiten Seite des Ultraschallsondenadapters (200) gegenüber dem ersten magnetischen Element positioniert ist; und
    - ein viertes magnetisches Element, das zur Einführung in jeden der echogenen Köpfe dimensioniert ist.
  17. Kit nach Anspruch 12, der weiter eine Spritze (118) umfasst, die zur Anbringung an das proximale Ende (112) des länglichen medizinischen Elements konfiguriert ist.
  18. Kit nach Anspruch 12, wobei das längliche medi-

nische Element weiter eine Leitung umfasst.

19. Kit nach Anspruch 12, wobei die echogenen Köpfe weiter Ballons (124) umfassen.

### Revendications

1. Système de manipulation d'un élément médical allongé dans le corps d'un patient, comprenant :

un adaptateur de sonde ultrasonore (200) comportant une sonde ultrasonore à l'intérieur ; et un élément médical allongé présentant une extrémité distale (120) et une extrémité proximale (112), ladite extrémité distale (120) dudit élément médical allongé comprenant en outre une tête échogène ;

dans lequel ledit adaptateur de sonde ultrasonore (200) et ladite extrémité distale (120) dudit élément médical allongé sont chacun configurés pour s'attirer magnétiquement l'un vers l'autre avec une force magnétique suffisante pour permettre un mouvement coordonné entre ledit adaptateur de sonde ultrasonore (200) et ladite tête échogène quand ledit adaptateur de sonde ultrasonore (200) et ladite tête échogène sont positionnés sur des côtés opposés d'au moins une surface de tissu sur le corps d'un patient.

2. Système selon la revendication 1, ledit adaptateur de sonde ultrasonore (200) comprenant en outre au moins un premier élément magnétique positionné adjacent à ladite sonde ultrasonore.
3. Système selon la revendication 2, dans lequel ledit premier élément magnétique est positionné de manière amovible à l'intérieur dudit adaptateur de sonde ultrasonore (200).
4. Système selon la revendication 2, ledit élément médical allongé comprenant en outre au moins un deuxième élément magnétique (126) positionné à l'intérieur de ladite extrémité distale (120) dudit élément médical allongé.
5. Système selon la revendication 4, dans lequel ledit deuxième élément magnétique (126) est positionné à l'intérieur de ladite tête échogène.
6. Système selon la revendication 5, dans lequel ladite tête échogène comprend en outre un ballon (124).
7. Système selon la revendication 6, dans lequel ledit premier élément magnétique est positionné sur un premier côté de ladite sonde ultrasonore, et ledit deuxième élément magnétique est positionné sur un premier côté dudit ballon (124), ledit système com-

prenant en outre :

un troisième élément magnétique positionné sur un second côté de ladite sonde ultrasonore opposé audit premier élément magnétique ; et un quatrième élément magnétique positionné sur un second côté dudit ballon (124) opposé audit deuxième élément magnétique.

8. Système selon la revendication 7, dans lequel lesdits premier et troisième éléments magnétiques sont espacés l'un de l'autre par une distance égale à une distance espaçant l'un de l'autre lesdits deuxième et quatrième éléments magnétiques.

9. Système selon la revendication 4, dans lequel ledit premier élément magnétique et ledit deuxième élément magnétique ont des champs magnétiques qui sont orientés de manière à attirer ladite extrémité distale (120) dudit élément médical allongé vers une surface inférieure dudit adaptateur.

10. Système selon la revendication 1, ledit élément médical allongé comprenant un conduit présentant un collet (132) monté de manière mobile à l'intérieur de celui-ci, un opérateur de collet adjacent à l'extrémité proximale (112) dudit conduit, et une section de fermeture de collet à l'extrémité distale (120) dudit conduit.

11. Système selon la revendication 10, dans lequel ladite section de fermeture dudit collet (132) est positionnée sur un intérieur de ladite tête échogène.

12. Kit de pose d'un élément médical allongé dans le corps d'un patient, comprenant :

le système selon la revendication 1 ; et une pluralité de têtes échogènes configurées pour être attachées à ladite extrémité distale (120) dudit élément médical allongé.

13. Kit selon la revendication 12, ledit adaptateur de sonde ultrasonore (200) comprenant en outre au moins un premier élément magnétique positionné adjacent à ladite sonde ultrasonore.

14. Kit selon la revendication 13, dans lequel ledit premier élément magnétique est positionné de manière amovible à l'intérieur dudit adaptateur de sonde ultrasonore (200).

15. Kit selon la revendication 13, comprenant en outre au moins un deuxième élément magnétique dimensionné pour être inséré à l'intérieur de chacune desdites têtes échogènes.

16. Kit selon la revendication 15, dans lequel ledit pre-

mier élément magnétique est positionné sur un premier côté dudit adaptateur de sonde ultrasonore (200), ledit kit comprenant en outre :

- un troisième élément magnétique (126) positionné sur un second côté dudit adaptateur de sonde ultrasonore (200) opposé audit premier élément magnétique ; et
  - un quatrième élément magnétique dimensionné pour être inséré à l'intérieur de chacune desdites têtes échogènes.
- 17.** Kit selon la revendication 12, comprenant en outre une seringue (118) configurée pour être attachée à ladite extrémité proximale (112) dudit élément médical allongé.
- 18.** Kit selon la revendication 12, dans lequel ledit élément médical allongé comprend en outre un conduit.
- 19.** Kit selon la revendication 12, dans lequel lesdites têtes échogènes comprennent en outre des ballons (124).

25

30

35

40

45

50

55

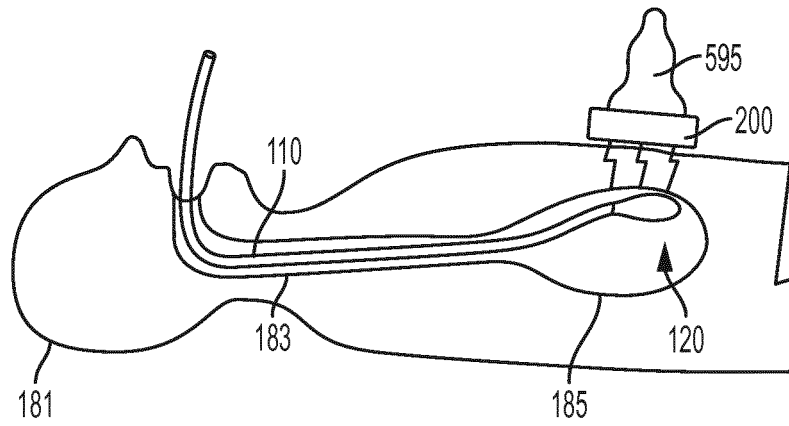

FIG. 1

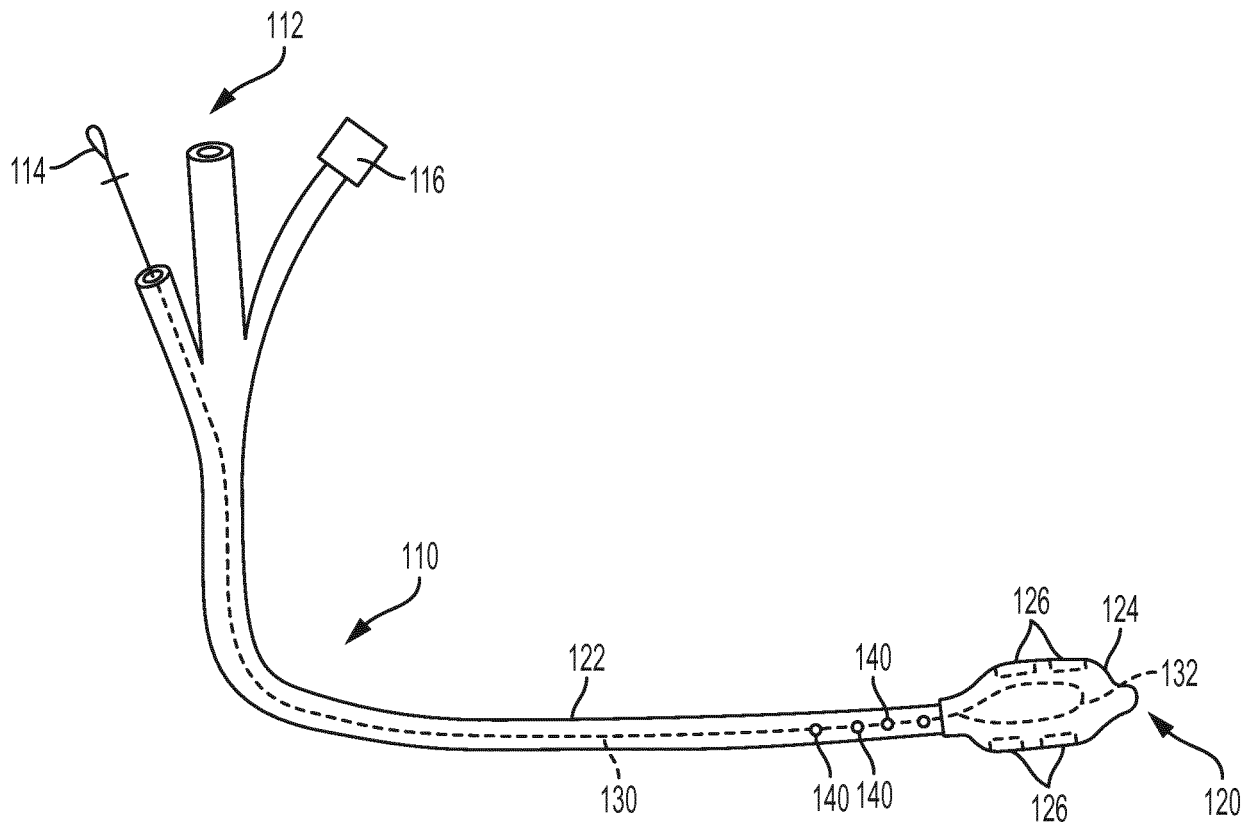

FIG. 2

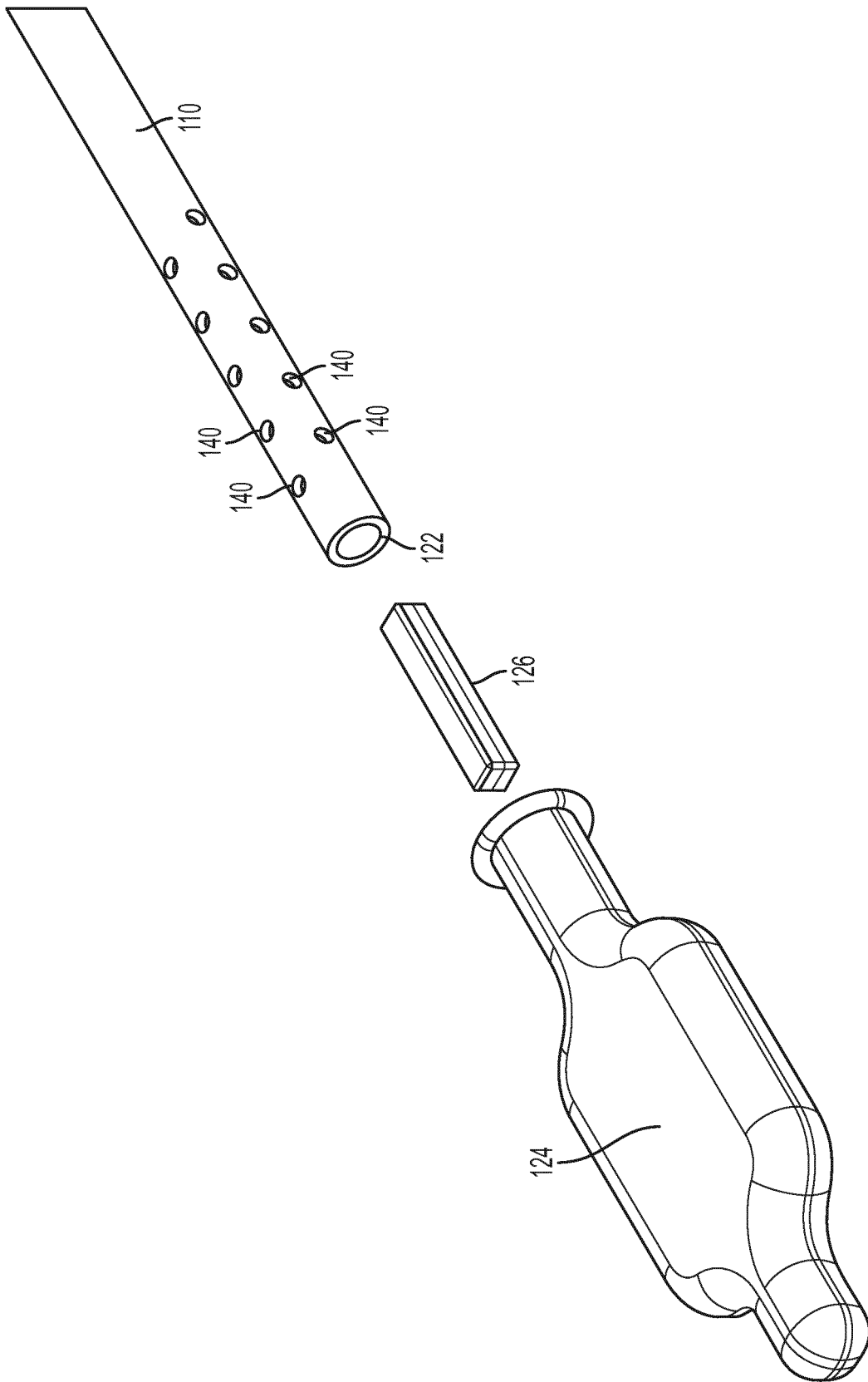

FIG. 3

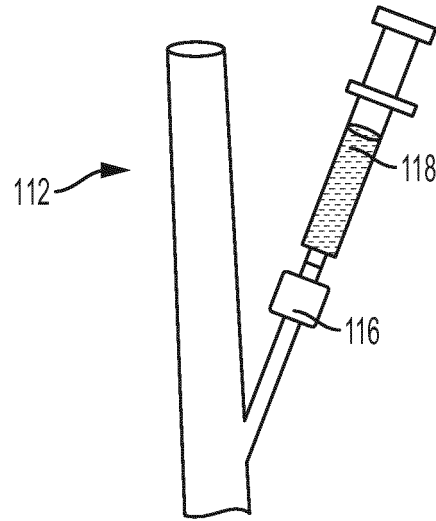

FIG. 4

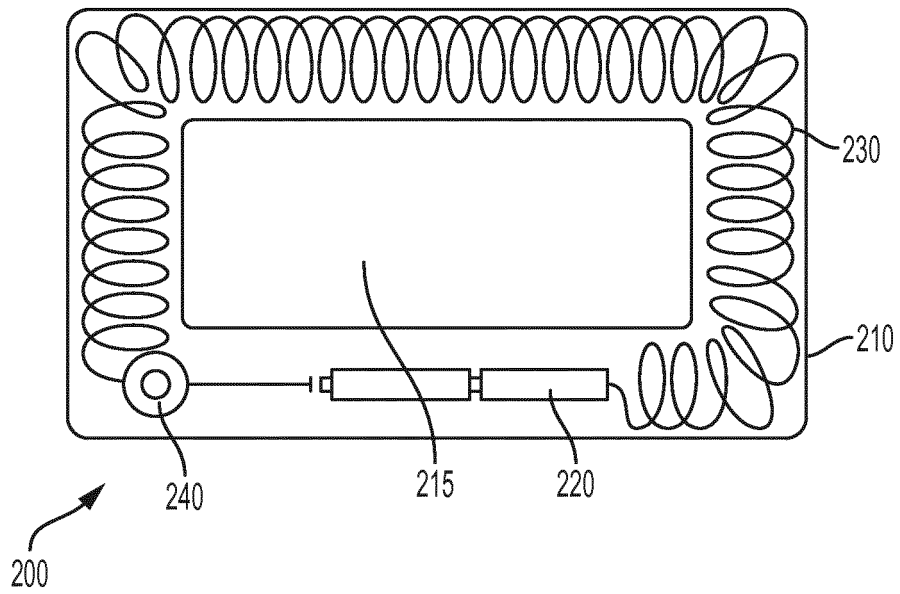

FIG. 5a

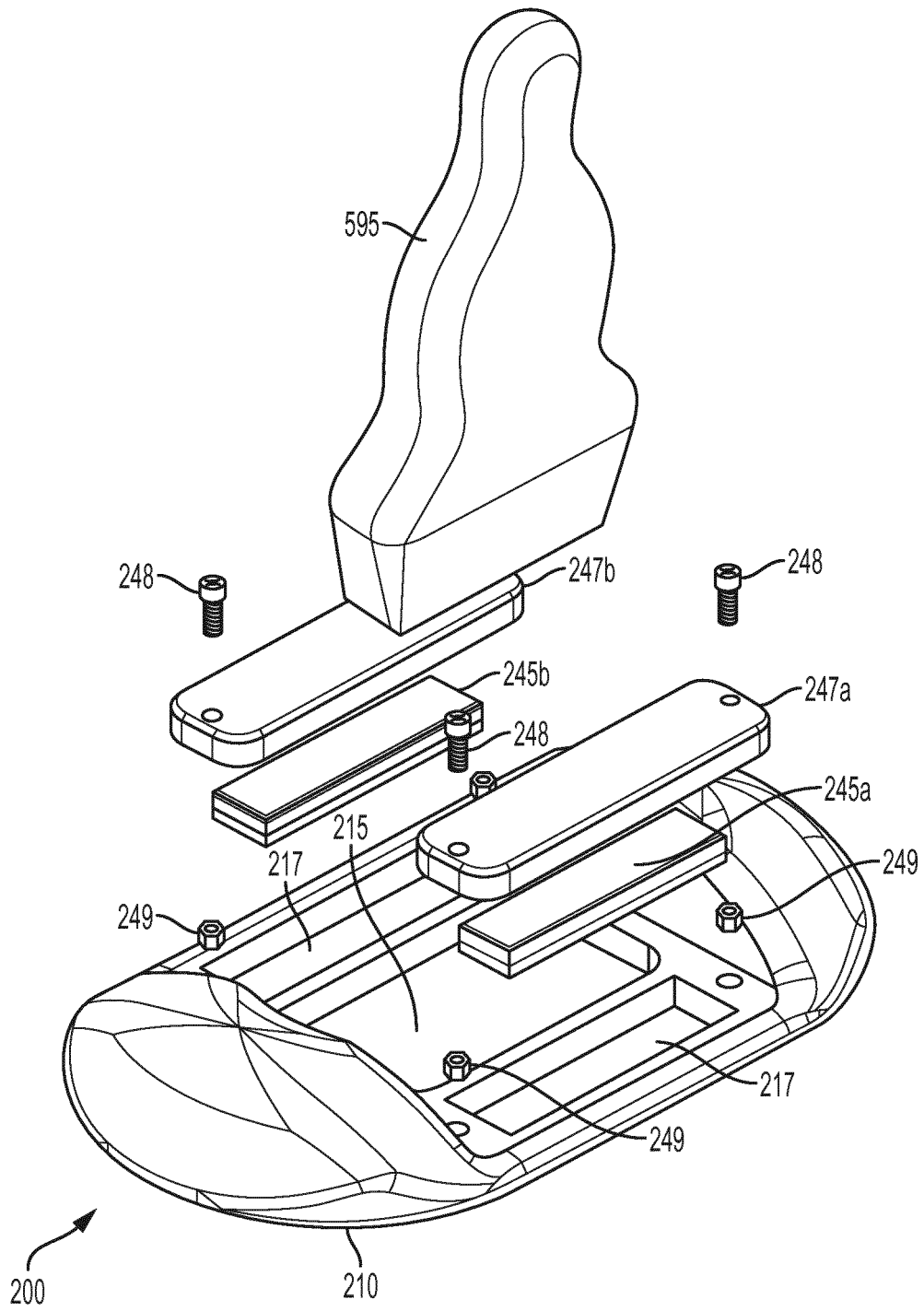

FIG. 5b

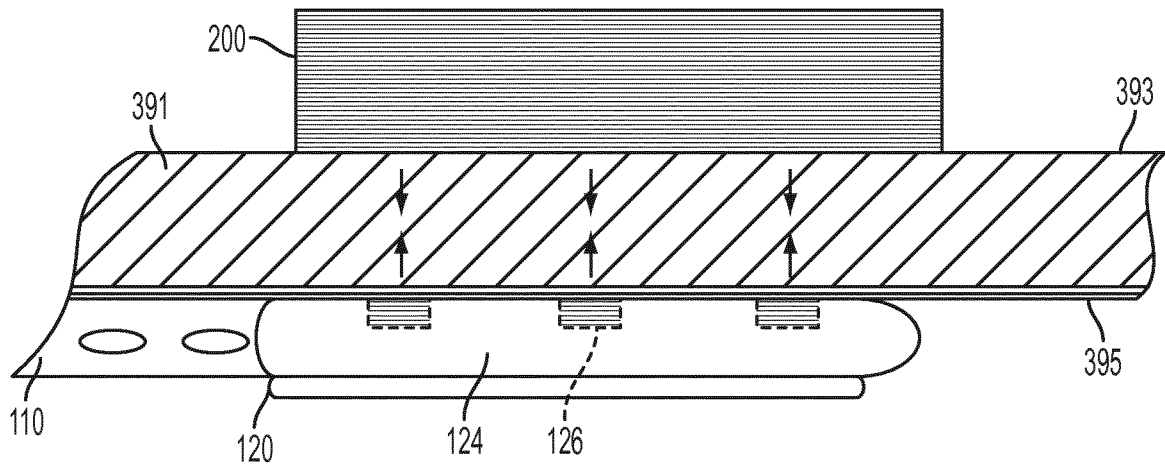

FIG. 6

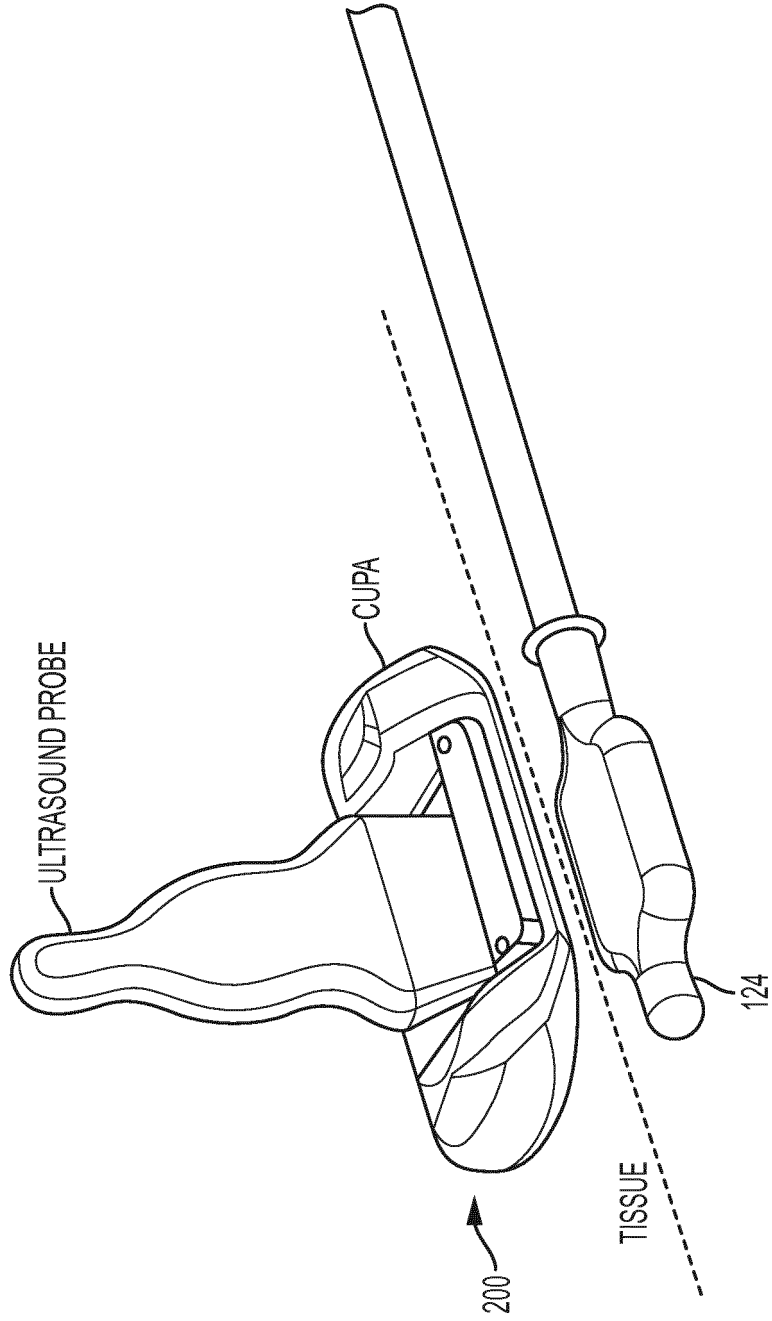

FIG. 7

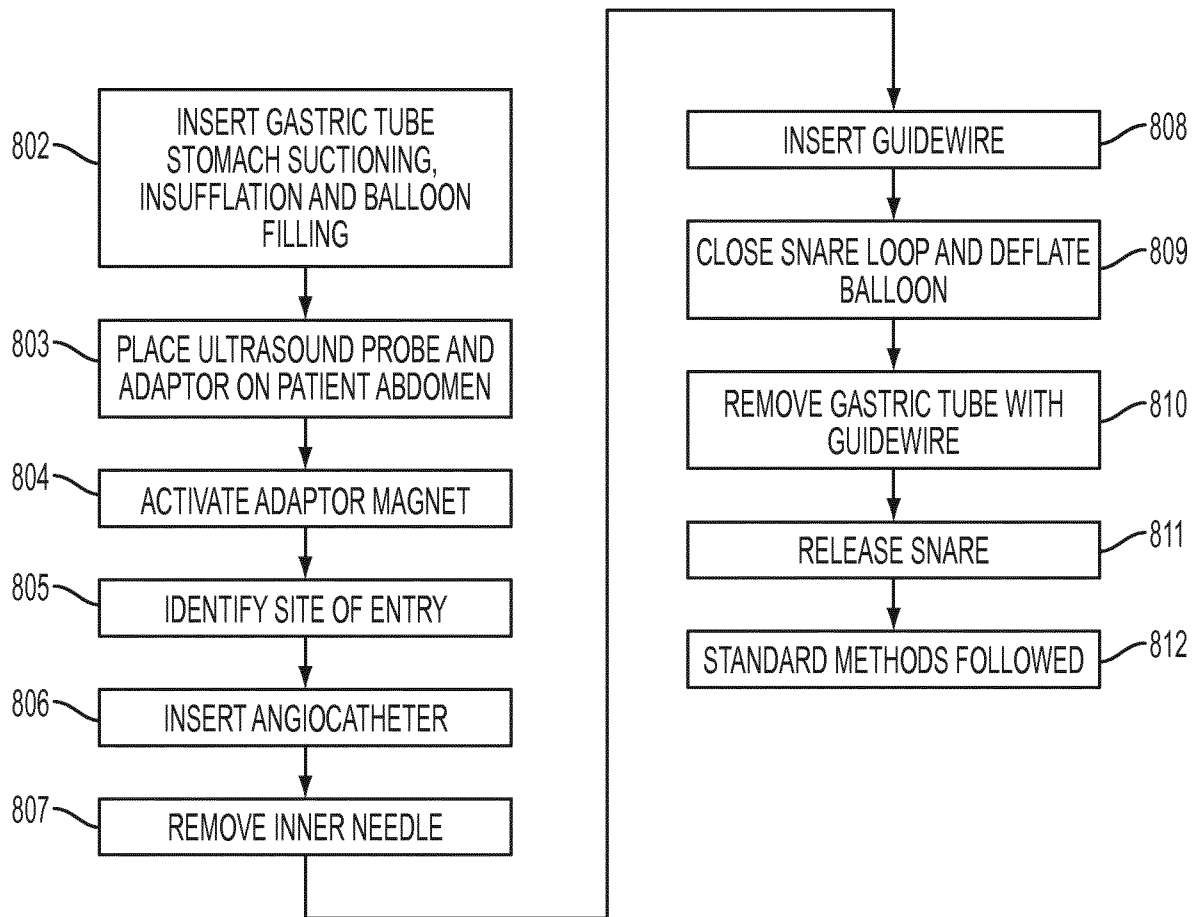

FIG. 8

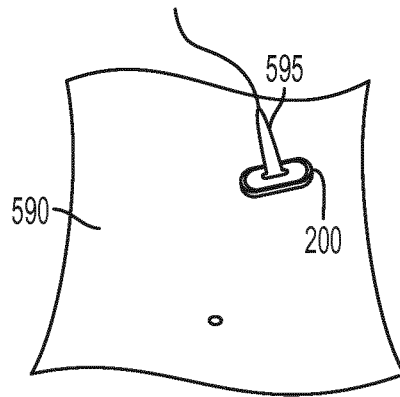

FIG. 9

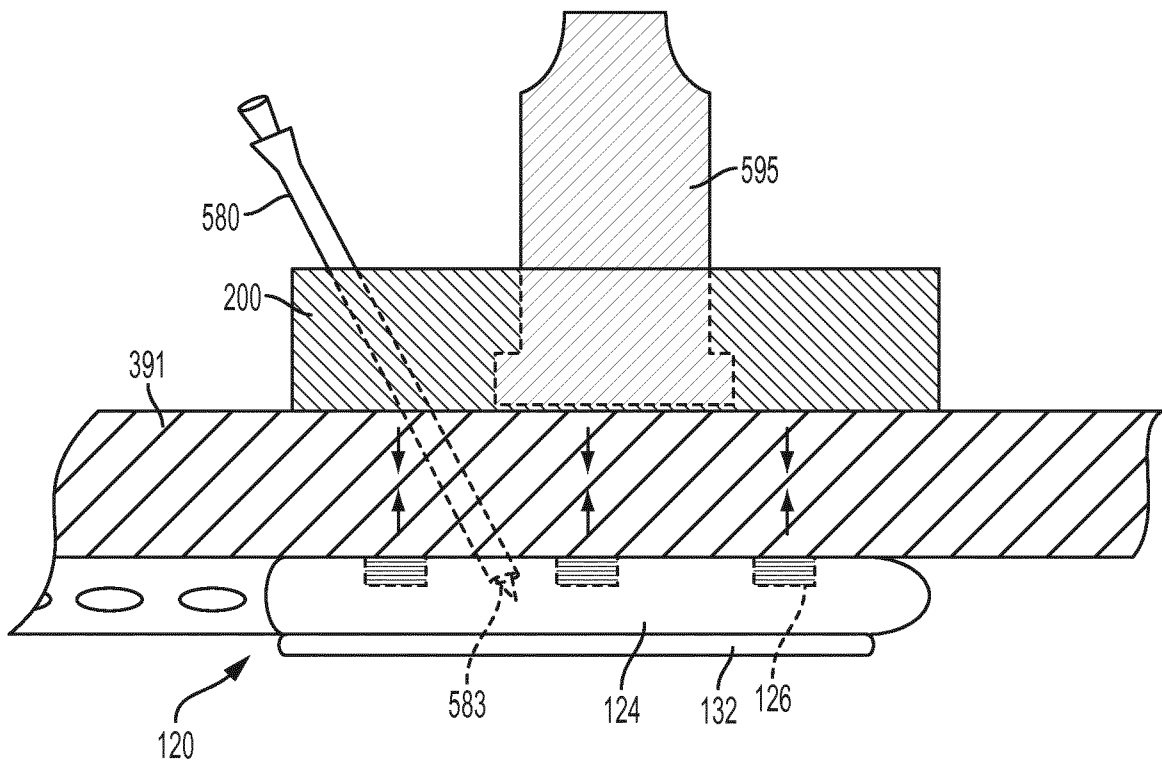

FIG. 10

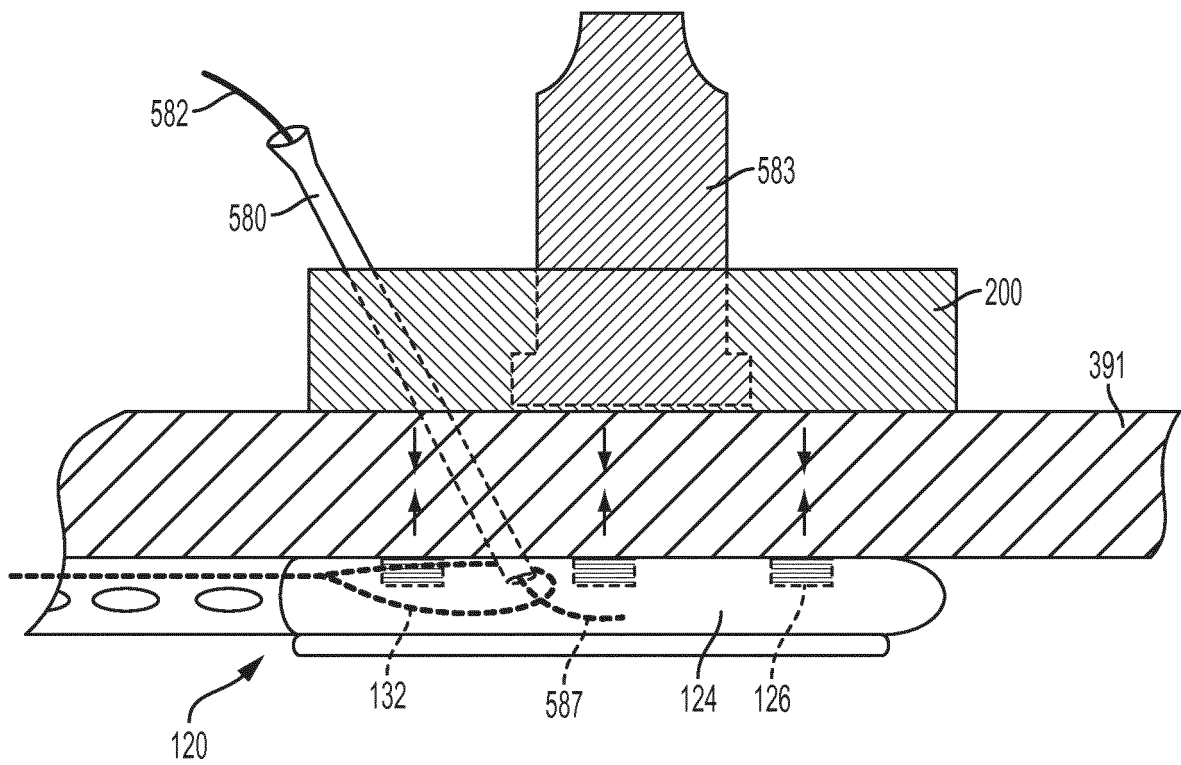

FIG. 11

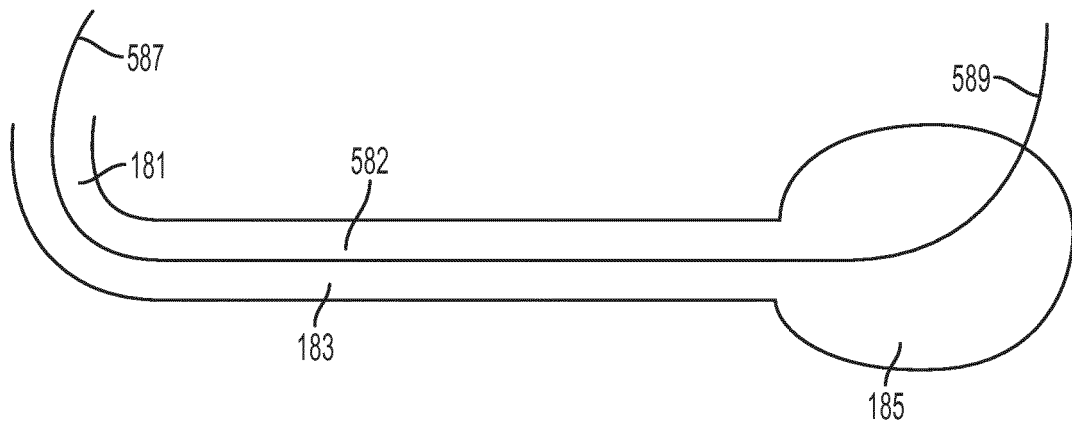

FIG. 12

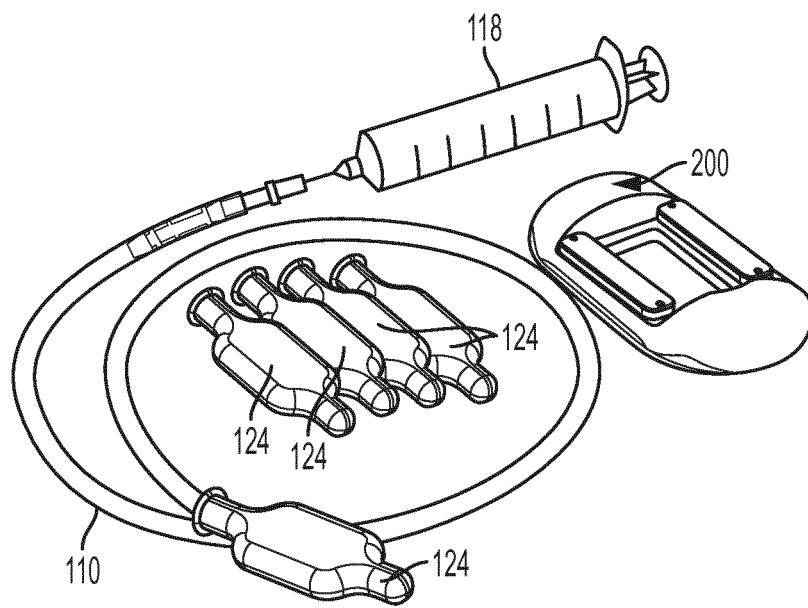

FIG. 13

**REFERENCES CITED IN THE DESCRIPTION**

*This list of references cited by the applicant is for the reader's convenience only. It does not form part of the European patent document. Even though great care has been taken in compiling the references, errors or omissions cannot be excluded and the EPO disclaims all liability in this regard.*

**Patent documents cited in the description**

- US 61814516 A [0001]
- US 2013072792 A [0011]
- WO 2010129327 A [0012]
- WO 2010036721 A [0013]
- US 2012197062 A [0014]

专利名称(译)	Coaptation超声装置和使用方法		
公开(公告)号	<a href="#">EP2988815A1</a>	公开(公告)日	2016-03-02
申请号	EP2014788472	申请日	2014-04-22
[标]申请(专利权)人(译)	马里兰大学巴尔的摩分校		
申请(专利权)人(译)	马里兰州巴尔的摩大学		
当前申请(专利权)人(译)	马里兰州巴尔的摩大学		
[标]发明人	TROPELLO STEVEN P		
发明人	TROPELLO, STEVEN, P.		
IPC分类号	A61M25/01 A61M25/10 A61B8/00 A61B8/08 A61B17/00 A61B17/34 A61B90/00 A61J15/00		
CPC分类号	A61B2017/00876 A61B2017/3413 A61B2090/378 A61J15/0003 A61J15/0088 A61M25/0158 A61M25/10 A61M2025/0166 A61B1/00158 A61B1/01 A61B8/0841 A61B8/4209 A61B8/481 A61M2025/1079		
优先权	61/814516 2013-04-22 US		
其他公开文献	EP2988815B1 EP2988815A4		
外部链接	<a href="#">Espacenet</a>		

#### 摘要(译)

公开了一种使用结合超声将细长医疗构件放置在患者体内的系统和方法，所述结合超声将磁引导与患者体内的医疗构件的超声可视化相结合。辅助超声探头适配器以足够的力磁性吸引患者体内的细长医疗构件，以允许操作者手动将构件引导至其预期位置。该适配器与超声波探头配合，为医疗操作员提供超声波对该部件位置的反馈，从而允许内部放置而无需更专业的医疗设备。