

(19)



(11)

EP 2 904 975 B1

(12)

EUROPEAN PATENT SPECIFICATION

(45) Date of publication and mention of the grant of the patent:
21.03.2018 Bulletin 2018/12

(51) Int Cl.:
A61B 8/00 (2006.01) A61B 8/08 (2006.01)

(21) Application number: **13843757.9**

(86) International application number:
PCT/JP2013/075765

(22) Date of filing: **24.09.2013**

(87) International publication number:
WO 2014/054469 (10.04.2014 Gazette 2014/15)

(54) **ULTRASOUND OBSERVATION DEVICE, OPERATION METHOD FOR ULTRASOUND OBSERVATION DEVICE, AND OPERATION PROGRAM FOR ULTRASOUND OBSERVATION DEVICE**

ULTRASCHALLBEOBACHTUNGSVORRICHTUNG, BETRIEBSVERFAHREN FÜR DIE ULTRASCHALLBEOBACHTUNGSVORRICHTUNG UND BETRIEBSPROGRAMM FÜR DIE ULTRASCHALLBEOBACHTUNGSVORRICHTUNG

DISPOSITIF D'OBSERVATION PAR ULTRASON, PROCÉDÉ DE FONCTIONNEMENT POUR DISPOSITIF D'OBSERVATION PAR ULTRASON, ET PROGRAMME DE FONCTIONNEMENT POUR DISPOSITIF D'OBSERVATION PAR ULTRASON

(84) Designated Contracting States:
AL AT BE BG CH CY CZ DE DK EE ES FI FR GB GR HR HU IE IS IT LI LT LU LV MC MK MT NL NO PL PT RO RS SE SI SK SM TR

(74) Representative: **Gunzelmann, Rainer Wuesthoff & Wuesthoff Patentanwälte PartG mbB Schweigerstraße 2 81541 München (DE)**

(30) Priority: **01.10.2012 JP 2012219764**

(43) Date of publication of application:
12.08.2015 Bulletin 2015/33

(56) References cited:
**WO-A1-93/19673 WO-A1-2012/063928
WO-A1-2012/063977 JP-A- H0 373 135
JP-A- H07 323 029 JP-A- 2004 321 582
JP-A- 2005 245 788 JP-A- 2012 157 387
US-A1- 2007 239 014 US-A1- 2012 215 110
US-B1- 8 002 705**

(73) Proprietor: **Olympus Corporation Tokyo 192-8507 (JP)**

(72) Inventor: **EDA, Hirotaka Hachioji-shi, Tokyo 192-8507 (JP)**

EP 2 904 975 B1

Note: Within nine months of the publication of the mention of the grant of the European patent in the European Patent Bulletin, any person may give notice to the European Patent Office of opposition to that patent, in accordance with the Implementing Regulations. Notice of opposition shall not be deemed to have been filed until the opposition fee has been paid. (Art. 99(1) European Patent Convention).

Description

Field

5 **[0001]** The present invention, which is defined in the claims, relates to an ultrasonic observation apparatus, an operation method of the ultrasonic observation apparatus, and an operation program of the ultrasonic observation apparatus, for observing tissue of a specimen by using ultrasonic waves.

Background

10 **[0002]** Conventionally, as an examination technique for breast cancer or the like using ultrasonic waves, a technique called ultrasonic elastography has been known (for example, see Patent Literature 1). Ultrasonic elastography is a technique of applying the fact that hardness of cancers and tumor tissue differs according to progress of the diseases and the organisms. In this technique, while a location to be examined is pressed from outside, a strain and an elastic modulus of biological tissue at that location to be examined are measured by using ultrasonic waves, and results of this measurement is image-displayed as tomographic images.

15

Citation List

20 Patent Literature

[0003] Patent Literature 1: International Patent Publication No. WO2005/122906

[0004] Document WO2012063928 A1 discloses an ultrasonic observation apparatus that is adapted to transmit an ultrasonic wave to a specimen and receives the ultrasonic wave reflected from the specimen, the ultrasonic observation apparatus comprising: a transmitting and receiving unit that is adapted to perform a transmission-and-reception of an ultrasonic wave on a sound ray in the region of interest, the transmission-and-reception of the ultrasonic wave being focused on the focus point; a frequency analysis unit that is adapted to calculate a plurality of frequency spectra by analyzing the ultrasonic wave received by the transmitting and receiving unit with reference to the focus point; a feature data extracting unit that is adapted to extract feature data of the frequency spectra calculated by the frequency analysis unit by approximating the frequency spectra, said spectrum being correlated with a tissue characteristic for tissue differentiation; and an image processing unit that is adapted to generate ultrasonic image data having a display mode corresponding to the feature data extracted by the feature data extracting unit, further comprising a B-mode image data generation unit that is adapted to generate B-mode image data for displaying brightness converted from amplitude of the ultrasonic wave reflected from the specimen, wherein the apparatus is adapted to use a focus point for the B-mode image, and wherein the transmitting and receiving unit is adapted to perform the transmission-and-reception of the ultrasonic wave which is focused on the focus point set for a B-mode image.

25

30

35

Summary

40 Technical Problem

[0005] In the above-described ultrasonic elastography, however, it is difficult to transmit the pressure to a lower part of a vascular channel such as blood vessel or lymph channel. For this reason, when a tumor is formed near the vascular channel, a boundary of the tumor is unclear, which makes it difficult to distinguish invasion of the tumor into the vascular channel. Thus, in the ultrasonic elastography, it may not be possible to accurately perform an observation of a specimen, such as differentiation of tissue characterization.

45

[0006] Further, in the ultrasonic elastography, the pressure or pressure velocity when a medical technologist presses the location to be examined varies from person to person; therefore, reliability of measurement results is low.

[0007] The present invention has been made in view of the foregoing, and an object of the invention is to provide an ultrasonic observation apparatus, an operation method of the ultrasonic observation apparatus, and an operation program of the ultrasonic observation apparatus that are capable of differentiating tissue characterization with accuracy and are able to improve reliability of observation results.

50

Solution to Problem

55 **[0008]** In order to solve the above described problems and achieve the object, an ultrasonic observation apparatus according to the invention as defined in the claims is provided, and which in use transmits an ultrasonic wave to a specimen and receives the ultrasonic wave reflected from the specimen. The ultrasonic observation apparatus includes

the features of claim 1.

[0009] The disclosed ultrasonic observation apparatus includes a storage unit that stores a parameter associated with size information of the region of interest. The focus point calculation unit calculates the focus points based on the parameter.

5 **[0010]** In the ultrasonic observation the size information of the region of interest is a size of the region of interest in a depth direction, and the parameter is the number of focus points in the region of interest.

[0011] In the disclosed ultrasonic observation the focus point calculation unit divides the region of interest into a plurality of partial regions of interest according to the number of focus points, calculates a focus point in each of the partial regions of interest, and determines a transmission timing according to the calculated focus point, and the transmitting and receiving unit performs a transmission-and-reception of an ultrasonic wave on a sound ray in the region of interest as many times as the number of focus points on the sound ray.

10 **[0012]** The disclosed frequency analysis unit calculates the frequency spectra by acquiring a data group forming a part of a data array of the ultrasonic wave received by the transmitting and receiving unit and by performing fast Fourier transform on the data group.

15 **[0013]** According to the disclosed ultrasonic observation apparatus the frequency analysis unit acquires the data group from a plurality of ultrasonic waves transmitted and received for one sound ray by using an ultrasonic wave in which a closest focus point exists on the sound ray.

[0014] According to the disclosed ultrasonic observation apparatus the focus point calculation unit calculates, as the focus point, a central position of each of the partial regions of interest in a depth direction.

20 **[0015]** According to the disclosed ultrasonic observation apparatus the focus point calculation unit calculates, as the focus point, a center of a data array in a depth direction in each of the partial regions of interest.

[0016] According to the disclosed ultrasonic observation apparatus the focus point calculation unit calculates, as the focus point, a specified data position in the data group.

25 **[0017]** The ultrasonic observation apparatus according to the disclosure further includes a B-mode image data generation unit that generates B-mode image data for displaying brightness converted from amplitude of the ultrasonic wave reflected from the specimen. The transmitting and receiving unit performs the transmission-and-reception of the ultrasonic wave which is focused on the focus point set for a B-mode image, and the focus point calculation unit does not set a focus point according to the number of focus points in the partial regions of interest including the focus point for the B-mode image.

30 **[0018]** The ultrasonic observation apparatus according to the disclosure further includes a display unit that is able to display an image corresponding to the ultrasonic image data generated by the image processing unit.

[0019] An operation method of an ultrasonic observation apparatus according to the invention of claim 8 is an operation method of an ultrasonic observation apparatus that transmits an ultrasonic wave to a specimen and receives the ultrasonic wave reflected from the specimen.

35 **[0020]** An operation program of an ultrasonic observation apparatus according to the invention of claim 9 is an operation program of an ultrasonic observation apparatus that transmits an ultrasonic wave to a specimen and receives the ultrasonic wave reflected from the specimen.

Advantageous Effects of Invention

40 **[0021]** According to the disclosure, a plurality of focus points are calculated in a region of interest which is to be set as an ultrasonic wave image, based on size information of the region of interest, and feature data is extracted by performing an frequency analysis on an ultrasonic wave which has been transmitted and received with respect to each focus point. Therefore, it is possible to differentiate tissue characterization with accuracy and to improve reliability of observation results.

Brief Description of Drawings

[0022]

50 FIG. 1 is a block diagram illustrating a configuration of an ultrasonic observation apparatus according to a first embodiment of the present invention.

FIG. 2 is a diagram illustrating a relation between receiving depth and amplification factor of an echo signal.

55 FIG. 3 is a diagram illustrating a relation between receiving depth and amplification factor in an amplification process performed by an amplification correction unit.

FIG. 4 is a diagram illustrating a focus point information table stored by a focus point information storage unit.

FIG. 5 is a flow chart illustrating an outline of a process of the ultrasonic observation apparatus according to the first embodiment of the present invention.

FIG. 6 is a diagram illustrating a display example of a B-mode image in a display unit.

FIG. 7 is a flow chart illustrating an outline of a process performed by a focus point calculation unit.

FIG. 8 is a diagram schematically illustrating an outline of an ultrasonic transmission process performed by an ultrasonic probe.

5 FIG. 9 is a diagram schematically illustrating a configuration of a calculation echo signal per sound ray received by a transmitting and receiving unit from the ultrasonic probe.

FIG. 10 is a flow chart illustrating an outline of a process performed by a frequency analysis unit.

FIG. 11 is a diagram schematically illustrating a data array of a sound ray.

10 FIG. 12 is a diagram specifically illustrating an FFT data group acquiring process performed by the frequency analysis unit.

FIG. 13 is a diagram illustrating an example (first example) of a frequency spectrum calculated by the frequency analysis unit.

FIG. 14 is a diagram illustrating an example (second example) of the frequency spectrum calculated by the frequency analysis unit.

15 FIG. 15 is a diagram illustrating a straight line determined from feature data related to a straight line illustrated in FIG. 13, the feature data having been subjected to attenuation correction.

FIG. 16 is a diagram illustrating a display example (first example) of a display image in the display unit.

FIG. 17 is a diagram illustrating a display example (second example) of the display image in the display unit.

20 FIG. 18 is a diagram schematically illustrating an outline of a focus point calculation process performed by an ultrasonic observation apparatus according to a second embodiment of the present invention.

FIG. 19 is a diagram schematically illustrating an outline of a focus point calculation process performed by an ultrasonic observation apparatus according to a third embodiment of the present invention.

Description of Embodiments

25 **[0023]** Hereinafter, with reference to the appended drawings, modes for carrying out the present invention (hereinafter, referred to as "embodiments") will be described.

(First Embodiment)

30 **[0024]** FIG. 1 is a block diagram illustrating a configuration of an ultrasonic observation apparatus according to a first embodiment of the present invention. An ultrasonic observation apparatus 1 illustrated in the figure is an apparatus for observing a specimen to be diagnosed, by using ultrasonic waves.

35 **[0025]** The ultrasonic observation apparatus 1 includes: an ultrasonic probe 2 that outputs an ultrasonic pulse to outside thereof and receives an ultrasonic echo reflected outside thereof; a transmitting and receiving unit 3 that performs transmission and reception of an electric signal to and from the ultrasonic probe 2; a calculation unit 4 that performs specified calculation on an electric echo signal converted from the ultrasonic echo; an image processing unit 5 that performs generation of image data corresponding to the electric echo signal converted from the ultrasonic echo; an input unit 6 that is realized by using an interface, such as a key board, a mouse, a touch panel, or the like, and receives input of various information; a display unit 7 that is realized by using a display panel made of a liquid crystal, an organic EL, or the like, and displays various information including an image generated by the image processing unit 5; a storage unit 8 that stores various types of information including information on tissue characterization of a known specimen; and a control unit 9 that performs operation control of the ultrasonic observation apparatus 1.

45 **[0026]** The ultrasonic probe 2 has a signal converter 21 that converts an electric pulse signal received from the transmitting and receiving unit 3 into an ultrasonic pulse (sound pulse signal) and converts an ultrasonic echo reflected from a specimen outside thereof into an electric echo signal. The ultrasonic probe 2 may cause an ultrasonic transducer to mechanically perform scanning or may cause a plurality of ultrasonic transducers to electronically perform scanning.

50 **[0027]** The transmitting and receiving unit 3 is electrically connected to the ultrasonic probe 2, transmits a pulse signal to the ultrasonic probe 2, and receives an echo signal, which is a received signal, from the ultrasonic probe 2. The received echo signal is for switching over between: an echo signal (hereinafter, referred to as "B-mode image echo signal") used by the image processing unit 5 in order to generate B-mode image data by converting amplitude of an echo signal to brightness; and an echo signal (hereinafter, referred to as "calculation echo signal") used by the calculation unit 4 in order to perform calculation. The switch-over between the B-mode image echo signal and the calculation echo signal is performed, under the control of the control unit 9, in units of frames or sound rays (line data).

55 **[0028]** The transmitting and receiving unit 3 generates a pulse signal, based on a focus point and a transmission timing set by a later described focus point calculation unit 42 and a preset waveform, transmits this generated pulse signal to the ultrasonic probe 2, performs processes, such as amplification and filtering, on the echo signal received by the ultrasonic probe 2, and thereafter, by performing A/D conversion, generates digital RF signals of the B-mode image

echo signal and calculation echo signal. If the ultrasonic probe 2 is to cause a plurality of ultrasonic transducers to electronically perform scanning, the transmitting and receiving unit 3 has a multi-channel circuit for beam combination corresponding to the plurality of ultrasonic wave sound wave generators.

[0029] The transmitting and receiving unit 3 has a signal amplification unit 31 that amplifies an echo signal. Specifically, the signal amplification unit 31 performs sensitivity time control (STC) correction that amplifies an echo signal with a larger receiving depth with a higher amplification factor. FIG. 2 is a diagram illustrating a relation between receiving depth and amplification factor of an echo signal. Receiving depth "z" illustrated in FIG. 2 is quantity calculated based on elapsed time from a time point at which ultrasonic reception starts. As illustrated in FIG. 2, amplification factor β (dB) linearly increases from β_0 to β_{th} ($> \beta_0$) as the receiving depth "z" increases, if the receiving depth "z" is less than a threshold value z_{th} . Further, the amplification factor β takes a constant value β_{th} if the receiving depth "z" is equal to or greater than the threshold value z_{th} . The threshold value z_{th} is a value at which an ultrasonic signal received from the specimen has almost attenuated and noises have become dominant. In more general, if the receiving depth "z" is less than the threshold value z_{th} , the amplification factor β monotonically increases as the receiving depth "z" increases.

[0030] The calculation unit 4 includes: a region of interest setting unit 41 that sets, according to input by the input unit 6, information on a position and a size of a region of interest (ROI); a focus point calculation unit 42 that sets a transmission timing; an amplification correction unit 43 that performs amplification correction of making amplification factor constant regardless of receiving depth for a digital RF signal output by the transmitting and receiving unit 3; a frequency analysis unit 44 that performs frequency analysis of an echo signal by performing fast Fourier transform (FFT) on a digital RF signal of a calculation echo signal output by the transmitting and receiving unit 3; and a feature data extracting unit 45 that extracts, by approximating a frequency spectrum (power spectrum) acquired by the frequency analysis performed by the frequency analysis unit 44, feature data of the frequency spectrum.

[0031] The region of interest setting unit 41 sets a region of interest, based on information on a size of a region of interest in a depth direction, a position of the region of interest and the number of sound rays, the information being specified and input by the input unit 6.

[0032] The focus point calculation unit 42 performs calculation (position setting) of a plurality of focus points in the region of interest, from the information on the size of the region of interest set by the region of interest setting unit 41 and a table of the numbers of focus points stored by a focus point information storage unit 81 (later described), which the storage unit 8 has, and determines the number of transmissions per sound ray and a transmission timing of the calculation echo signal. Further, the focus point calculation unit 42 determines a focus point, the number of transmissions, and a transmission timing of the B-mode image echo signal.

[0033] FIG. 3 is a diagram illustrating a relation between receiving depth and amplification factor in an amplification process performed by the amplification correction unit 43. As illustrated in FIG. 3, the amplification factor β (dB) in the amplification process performed by the amplification correction unit 43 takes the maximum value $\beta_{th} - \beta_0$ when the receiving depth "z" is zero, linearly decreases until the receiving depth "z" reaches the threshold value z_{th} from zero, and is zero when the receiving depth "z" is equal to or greater than the threshold value z_{th} . By the amplification correction unit 43 performing the amplification correction on the digital RF signal with the amplification factor determined as described above, influence of STC correction in the signal amplification unit 31 is able to be offset and a signal of a constant amplification factor β_{th} is able to be output. Of course, the relation between the receiving depth "z" and the amplification factor β used by the amplification correction unit 43 differs according to the relation between the receiving depth and the amplification factor in the signal amplification unit 31.

[0034] The frequency analysis unit 44 calculates frequency spectra at a plurality of locations (data positions) on a sound ray, by performing fast Fourier transform on an FFT data group formed of a specified data amount, for each sound ray. Frequency spectra demonstrate different trends according to tissue characterization of the specimen. This is because, a frequency spectrum has a correlation with size, density, sound impedance, and the like of the specimen as a scatterer that scatters ultrasonic waves. "Tissue characterization" herein is any of, for example, cancer, endocrine tumor, mucinous tumor, pancreatitis, vessel, and the like.

[0035] The feature data extracting unit 45 extracts, by approximating a frequency spectrum of each data position calculated by the frequency analysis unit 44, feature data of that frequency spectrum. The feature data extracting unit 45 has: an approximation unit 451 that calculates, by performing an approximation process on the frequency spectrum calculated by the frequency analysis unit 44, pre-correction feature data before being subjected to an attenuation correction process; and an attenuation correction unit 452 that extracts feature data by performing the attenuation correction process on the pre-correction feature data approximated by the approximation unit 451.

[0036] The approximation unit 451 approximates the frequency spectrum with a linear equation by regression analysis and extracts pre-correction feature data that characterize this approximated linear equation. Specifically, the approximation unit 451 calculates a gradient a_0 and an intercept b_0 of the linear equation by regression analysis and calculates, as the pre-correction feature data, intensity at a particular frequency within a frequency band in the frequency spectrum. In this first embodiment, the approximation unit 451 uses a mid-frequency $f_{MID} = (f_{LOW} + f_{HIGH}) / 2$ as the particular frequency and calculates an intensity (mid-band fit) $c_0 = a_0 f_{MID} + b_0$ at this mid-frequency f_{MID} , but that is just an example.

EP 2 904 975 B1

The "intensity" referred to herein means any of parameters such as voltage, electric power, sound pressure, and sound energy.

[0037] Of the three feature data, the gradient a_0 has a correlation with a size of a scatterer of ultrasonic waves and in general, is considered to have a smaller value as the scatterer becomes larger. Further, the intercept b_0 has a correlation with the size of the scatterer, a difference in sound impedances, a density (concentration) of the scatterer, and the like. Specifically, the intercept b_0 is considered to have a larger value as the scatterer becomes larger, have a larger value as the sound impedance becomes greater, and have a larger value as the density (concentration) of the scatterer becomes larger. The intensity c_0 at the mid-frequency f_{MID} (hereinafter, simply referred to as "intensity") is an indirect parameter derived from the gradient a_0 and the intercept b_0 and gives a spectrum intensity at the center of an effective frequency band. Therefore, the intensity c_0 is considered to have a certain degree of correlation with brightness of a B-mode image, in addition to the size of the scatterer, the difference between the sound impedances, and the density of the scatterer. The approximation equation calculated by the approximation unit 451 is not limited to a linear equation and may be a polynomial equation of the second or higher order.

[0038] Next, correction performed by the attenuation correction unit 452 will be described. In general, an attenuation amount "A" of a sound wave is able to be expressed by the following.

$$A = 2\alpha z f \quad (1)$$

Here, α is an attenuation factor and "z" is the receiving depth of an ultrasonic wave, and "f" is frequency. As is clear from equation (1), the attenuation amount "A" is proportional to the frequency "f". A specific value of the attenuation factor α is, for an organism, 0 to 1.0 (dB/cm/MHz), and more preferably, is 0.3 to 0.7 (dB/cm/MHz), and is determined according to a type of an organ to be observed. In the first embodiment, a configuration that allows the value of the attenuation factor α to be changed by input from the input unit 6 may be used.

[0039] The attenuation correction unit 452 corrects the pre-correction feature data (gradient a_0 , intercept b_0 , intensity c_0) extracted by the approximation unit 451, as follows.

$$a = a_0 + 2\alpha z \quad (2)$$

$$b = b_0 \quad (3)$$

$$c = c_0 + 2\alpha z f_{MID} (= a f_{MID} + b) \quad (4)$$

As is clear from Equations (2) and (4), the attenuation correction unit 452 performs correction of a larger correction amount as the receiving depth "z" of the ultrasonic wave increases. Further, according to Equation (3), the correction related to the intercept is identical transformation. This is because, the intercept is a frequency component corresponding to a frequency of 0 (Hz) and does not attenuate.

[0040] The image processing unit 5 generates ultrasonic image data having a display mode corresponding to the feature data extracted by the feature data extracting unit 45. The image processing unit 5 has: a B-mode image data generation unit 51 that generates B-mode image data for displaying brightness converted from amplitude of a B-mode image echo signal; and a display image data generation unit 52 that generates display image data by using data respectively output by the B-mode image data generation unit 51 and the calculation unit 4.

[0041] The B-mode image data generation unit 51 generates the B-mode image data by performing signal processing using a known technique such as a band pass filter, logarithmic transformation, gain processing, contrast processing, or the like on a digital signal and by performing decimation or the like of data according to a step width of the data determined according to an image display range in the display unit 7.

[0042] The display image data generation unit 52 generates display image data including tissue characterization highlighted image that highlights tissue characterization of a subject, by using the B-mode image data generated by the B-mode image data generation unit 51 and the feature data calculated by the feature data extracting unit 45.

[0043] The input unit 6 is realized by using the interface such as the key board, mouse, touch panel, or the like. The input unit 6 receives input of information specifying the region of interest by a user of the ultrasonic observation apparatus 1, who has seen an image generated by the image processing unit 5.

[0044] The storage unit 8 includes: a focus point information storage unit 81 that stores the number of focus points and a size in a depth direction in a region of interest in association with each other; an amplification factor information

storage unit 82 that stores information of an amplification factor that the signal amplification unit 31 and the amplification correction unit 43 refer to when an amplification process is performed; a window function storage unit 83 that stores a window function used upon a frequency analysis process performed by the frequency analysis unit 44; and a correction information storage unit 84 that stores correction information that the attenuation correction unit 452 refers to when the attenuation correction unit 452 performs a process.

[0045] The focus point information storage unit 81 stores the number of focus points, and the size of the region of interest in the depth direction which is size information of the region of interest, in association with each other. FIG. 4 is a diagram illustrating a focus point information table stored by the focus point information storage unit 81. In a focus point information table Tb illustrated in this figure, as a size "w" of the region of interest in the depth direction becomes greater, the number of focus points increases stepwisely. Specifically, when $w = 1$ or 2 (cm), the number of focus points is one, when $w = 3$ (cm), the number of focus points is two, and when $w = 4$ or 5 (cm), the number of focus points is three. The number of focus points corresponds to the number of region divisions in the region of interest and also corresponds to the number of ultrasonic transmissions per sound ray.

[0046] The amplification factor information storage unit 82 stores the relation between the amplification factor and receiving depth illustrated in FIGS. 2 and 3.

[0047] The window function storage unit 83 stores at least any one window function or a plurality of window functions of Hamming, Hanning, and Blackman window functions and the like.

[0048] The correction information storage unit 84 stores information on attenuation correction including Equations (2) to (4).

[0049] The storage unit 8 is realized by using a ROM, in which an operation program of the ultrasonic observation apparatus 1, a program that activates a specified OS and the like are stored beforehand, a RAM that stores calculation parameters and data of each processes, and the like.

[0050] The control unit 9 is realized by using a CPU that has calculating and controlling functions. The control unit 9 executes various calculation processes related to an operation method of the ultrasonic observation apparatus 1 by reading from the storage unit 8 information and various programs including the operation program of the ultrasonic observation apparatus 1 stored by the storage unit 8 to thereby comprehensively control the ultrasonic observation apparatus 1.

[0051] Structural elements other than the transducer 2 of the ultrasonic observation apparatus 1 having the above described functions and configuration is realized by using one computer or a plurality of computers.

[0052] The operation program of the ultrasonic observation apparatus 1 may be recorded in a computer readable recording medium, such as a hard disk, a flash memory, a CD-ROM, a DVD-ROM, or a flexible disk, and widely distributed.

[0053] FIG. 5 is a flow chart illustrating an outline of a process of the ultrasonic observation apparatus 1 having the above described configuration. In FIG. 5, the ultrasonic observation apparatus 1 performs measurement of a new specimen by using the ultrasonic probe 2 (step S1).

[0054] Subsequently, the signal amplification unit 31 that has received an echo signal from the ultrasonic probe 2 performs amplification of that echo signal (step S2).

The signal amplification unit 31 performs the amplification based on the relation between the amplification factor and the receiving depth illustrated in FIG. 2.

[0055] Thereafter, the B-mode image data generation unit 51 generates B-mode image data by using a B-mode image echo signal output by the transmitting and receiving unit 3 (step S3).

[0056] Subsequently, the control unit 9 performs control to cause the display unit 7 to display a B-mode image corresponding to the B-mode image data generated by the B-mode image data generation unit 51 (step S4). FIG. 6 is a diagram illustrating a display example of the B-mode image in the display unit 7. A B-mode image 100 illustrated in this figure is a gray scale image in which values of red (R), green (G), and blue (B), which are variables when an RGB color system is used as a color space, are matched with one another.

[0057] Thereafter, if the region of interest setting unit 41 sets a region of interest according to input by the input unit 6 (step S5: Yes), the amplification correction unit 43 performs, on a signal output from the transmitting and receiving unit 3, correction such that the amplification factor becomes constant regardless of the receiving depth (step S6). The amplification correction unit 43 performs an amplification process based on the relation between the amplification factor and receiving depth illustrated in FIG. 3. The region of interest in the B-mode image may be arbitrarily set by a user via the input unit 6.

[0058] If the region of interest is not set by the region of interest setting unit 41 in step S5 (step S5: No) and an instruction to end the process is input by the input unit 6 (step S7, Yes), the ultrasonic observation apparatus 1 ends the process. In contrast, if the region of interest has not been set (step S5: No) and the instruction to end the process has not been input by the input unit 6 (step S7: No), the ultrasonic observation apparatus 1 returns to step S5.

[0059] Subsequently, the focus point calculation unit 42 determines the number of transmissions and a transmission timing for acquiring a calculation echo signal (step S8). FIG. 7 is a flow chart illustrating an outline of a process of determining the number of transmissions and transmission timing performed by the focus point calculation unit 42. First,

the focus point calculation unit 42 acquires a size in a depth direction of the region of interest specified in step S5 (step S21).

[0060] Thereafter, the focus point calculation unit 42 refers to a focus point number table stored in the storage unit 8 and determines the number of focus points (the number of transmissions) corresponding to the acquired size of the region of interest in the depth direction (step S22).

[0061] Subsequently, the focus point calculation unit 42 divides the region of interest into the determined number of focus points in the depth direction, and sets a central position in the depth direction in each divided partial region of interest as a focus point (step S23). At step S23, the focus point calculation unit 42 may calculate, as the focus point, a central data position of a data array in the depth direction in each partial region of interest.

[0062] Lastly, the focus point calculation unit 42 determines a transmission timing such that an ultrasonic wave is focused to the position of each set focus point (step S24).

[0063] As described above, the focus point calculation unit 42 determines the number of transmissions and transmission timing for acquiring an echo signal. Thereafter, the ultrasonic observation apparatus 1 returns to a main routine illustrated in FIG. 5.

[0064] Subsequently to the above described step S8, the transmitting and receiving unit 3 transmits a pulse signal that has been set beforehand to the ultrasonic probe 2 at the determined transmission timing and receives a calculation echo signal, which is a received signal from the ultrasonic probe 2 (step S9).

[0065] FIG. 8 is a diagram schematically illustrating an outline of an ultrasonic transmission process performed by the ultrasonic probe 2. In FIG. 8, a case in which a size "w" of a region of interest in a depth direction is 4 cm is illustrated. In this case, if a relation between "w" and the number of focus points follows the focus point information table Tb illustrated in FIG. 4, the number of focus points is three. Therefore, a region of interest RA is divided into three partial regions of interest RA(1), RA(2), and RA(3), and to a partial region of interest RA(j) (j = 1, 2, 3), a focus point FP(j) is set (see the above described step S23).

[0066] In the case illustrated in FIG. 8, an ultrasonic transducer 22 of the ultrasonic probe 2 sequentially transmits, for one sound ray, three ultrasonic waves at specified transmission timing and receives a calculation echo signal, the three ultrasonic waves forming sound fields having the three focus points respectively set in the partial regions of interest at their centers. Specifically, in a first transmission and reception, the ultrasonic transducer 22 forms a sound field SF1 approximately symmetrical in a travelling direction of the ultrasonic wave with a focus point FP(1) at its center. Further, in a second transmission and reception, the ultrasonic transducer 22 forms a sound field SF2 approximately symmetrical in the travelling direction of the ultrasonic wave with a focus point FP(2) at its center. Furthermore, in a third transmission and reception, the ultrasonic transducer 22 forms a sound field SF3 approximately symmetrical in the travelling direction of the ultrasonic wave with a focus point FP(3) at its center. In FIG. 8, although one sound ray at the center of the region of interest RA is exemplified, actually, for every sound ray included in the region of interest RA, a process similar to that described above (ultrasonic transmission and reception) is of course performed.

[0067] FIG. 9 is a diagram schematically illustrating a configuration of calculation echo signals per sound ray received from the ultrasonic probe 2 by the transmitting and receiving unit 3 in step S9. Sound rays LD(1) to LD(3) illustrated the figure are calculation echo signals respectively received by the transmitting and receiving unit 3 in the first transmission and reception to third transmission and reception, and a white or black rectangle in each signal means one data. Further, the sound rays LD(1) to LD(3) are discretized at time intervals corresponding to a sampling frequency (for example, 50 MHz) in A/D conversion performed by the transmitting and receiving unit 3. The black rectangle illustrated in FIG. 9 means a data position representing an FFT data group acquired by the frequency analysis unit 44. This point will be described in detail with reference to later described step S11.

[0068] Thereafter, if ultrasonic transmissions and receptions of a specified number of transmissions for every sound ray have been completed (step S10: Yes), the frequency analysis unit 44 performs frequency analysis of the calculation echo signals (step S11). In contrast, if the ultrasonic transmissions and receptions of the specified number of transmissions for every sound ray have not been completed (step S10: No), the ultrasonic observation apparatus 1 returns to step S9.

[0069] A process (step S11) performed by the frequency analysis unit 44 will now be described in detail with reference to a flow chart illustrated in FIG. 10. First, the frequency analysis unit 44 sets a sound ray number "L" of a sound ray to be analyzed first as an initial value L_0 (step S31). The initial value L_0 may be given to a sound ray first received by the transmitting and receiving unit 3, or given to a sound ray corresponding to one of right and left boundary positions of the region of interest set by the input unit 6, for example.

[0070] Subsequently, the frequency analysis unit 44 calculates all of frequency spectra on the sound ray of the calculation echo signal received in step S10. First, the frequency analysis unit 44 sets an initial value Z_0 of data position "Z" (corresponding to a receiving depth) representing a series of data groups (FFT data groups) acquired for FFT calculation (step S32).

[0071] FIG. 11 is a diagram schematically illustrating a data array of a sound ray. In FIG. 11, a case is illustrated, in which the number of transmissions for one sound ray is i_{\max} , the first data of the calculation echo signals LD(1) to LD(i_{\max}) corresponding to the first transmission and reception to the i_{\max} -th transmission and reception are set as an initial values Z_0 of data position "Z", and the data positions are set by a step width "D". Therefore, a black area of each calculation

echo signal illustrated in FIG. 11 represents the data position and the step width "D" is fifteen. A position of the initial value Z_0 may be arbitrarily set. For example, a data position "Z" corresponding to a top end position of the region of interest may be set as the initial value Z_0 .

[0072] Thereafter, the frequency analysis unit 44 acquires the FFT data group at the data position "Z" (step S33). The frequency analysis unit 44 compares the data position "Z" to be acquired and a position of a focus point FP(i) of each calculation echo signal, and acquires the FFT data group at that data position "Z" by using the calculation signal having the smallest distance to the focus point. The FFT data group needs to have the number of data of the power of two. Hereinafter, the number of data of the FFT data group is assumed to be 2^n (where "n" is a positive integer). The number of data of the FFT data group being 2^n means that before the data position "Z", there are $2^{n-1} - 1 (= N)$ data, and after the data position "Z", there are $2^{n-1} (= M)$ data.

[0073] FIG. 12 is a diagram specifically illustrating the process of step S33. In FIG. 12, a case, in which the number of transmissions i_{\max} in one sound ray is three, is illustrated. Further, in FIG. 12, the number of data of one FFT data group is fifteen. Therefore, $n = 4$, $N = 7$, and $M = 8$. Furthermore, the region of interest RA is the same as that described with reference to FIG. 8. In this case, the frequency analysis unit 44 compares the data position "Z" to be acquired with a position of a focus point of each calculation echo signal, and acquires, in the sound ray LD(1) of the first transmission and reception, FFT data groups F_1, \dots, F_i , and F_{i+1} (where "i" is a positive integer) at the data positions included in from the initial value Z_0 to the partial region of interest RA(1). Further, the frequency analysis unit 44 acquires, in the sound ray LD(2) of the second transmission and reception, FFT data groups F_{i+2} and F_{i+3} at the data positions included in the partial region of interest RA(2). Further, the frequency analysis unit 44 acquires, in the sound ray LD(3) of the third transmission and reception, FFT data groups F_{i+4}, \dots, F_{K-1} , and F_K included in from the partial region of interest RA(3) to the last data position of the sound ray LD(3).

[0074] Subsequently, the frequency analysis unit 44 applies a window function stored by the window function storage unit 83 to the acquired FFT data groups (step S34). Accordingly, by the frequency analysis unit 44 applying the window function to the acquired FFT data groups, the FFT data groups are able to be prevented from becoming discontinuous at boundaries and generation of artifacts is able to be prevented.

[0075] Thereafter, the frequency analysis unit 44 determines whether or not the FFT data group at the data position "Z" is a normal data group or not (step S35). The FFT data group being normal means that there are N data before the data position "Z" and there are M data after the data position "Z". In the case illustrated in FIG. 12, all except the FFT data groups F_1 and F_K are normal.

[0076] As a result of the determination in step S35, if the FFT data group at the data position "Z" is normal (step S35: Yes), the frequency analysis unit 44 proceeds to later described step S37.

[0077] As a result of the determination in step S35, if the FFT data group at the data position "Z" is not normal (step S35: No), the frequency analysis unit 44 generates a normal data group by inserting zero data worth the deficit (step S36). The FFT data group determined to be not normal in step S35 has been applied with the window function before the zero data are added. Therefore, even if the zero data are inserted in the FFT data group, the data do not become discontinuous. After step S36, the frequency analysis unit 44 proceeds to later described step S37.

[0078] At step S37, the frequency analysis unit 44 acquires a frequency spectrum by performing FFT calculation using the FFT data group (step S37). FIG. 13 and FIG. 14 are diagrams illustrating examples of the frequency spectrum calculated by the frequency analysis unit 44. In FIG. 13 and FIG. 14, a horizontal axis "f" represents frequency and a vertical axis "I" represents intensity. In the frequency spectrum curves C_1 and C_2 illustrated respectively in FIG. 13 and FIG. 14, lower limit frequencies f_{LOW} and upper limit frequencies f_{HIGH} of the frequency spectra are parameters determined based on a frequency band of the ultrasonic probe 2, a frequency band of the pulse signal transmitted by the transmitting and receiving unit 3, and the like, and for example, $f_{\text{LOW}} = 3$ MHz and $f_{\text{HIGH}} = 10$ MHz. In this first embodiment, a curve and a straight line are each formed of a group of discrete points. A straight line L_1 illustrated in FIG. 13 and a straight line L_2 illustrated in FIG. 14 will be described with reference to a later described pre-correction feature data extraction process (step S12).

[0079] Subsequently, the frequency analysis unit 44 calculates a data position "Z" of an FFT data group to be next analyzed by adding the specified step width "D" to the data position "Z" (step S38). This step width "D" preferably coincides with the step width used when the B-mode image data are generated by the B-mode image data generation unit 51, but if an amount of calculation in the frequency analysis unit 44 is desired to be decreased, a value larger than the step width used by the B-mode image data generation unit 51 may be set.

[0080] Thereafter, the frequency analysis unit 44 determines whether or not the data position "Z" is greater than the last data position Z_{\max} (step S39). The last data position Z_{\max} may be a data length of the calculation echo signals LD(1) to LD(n) or a data position corresponding to a lower end of the region of interest. As a result of the determination, if the data position "Z" is larger than the last data position Z_{\max} (step S39: Yes), the frequency analysis unit 44 increments the sound ray number "L" by one (step S40). On the contrary, if the data position "Z" is equal to or less than the last data position Z_{\max} (step S39: No), the frequency analysis unit 44 returns to step S33. Accordingly, the frequency analysis unit 44 performs the FFT calculation for a total of $\{(Z_{\max} - Z_0)/D\} + 1 (= K)$ FFT data groups for the calculation echo

signals LD(1) to LD(i_{\max}). Here, [X] represents a maximum integer not exceeding "X".

[0081] If the sound ray number "L" that has been incremented in step S40 is larger than the last sound ray number L_{\max} (step S41: Yes), the frequency analysis unit 44 ends the frequency analysis process. Thereafter, the ultrasonic observation apparatus 1 returns to the main routine illustrated in FIG. 5. On the contrary, if the sound ray number "L" that has been incremented in step S41 is equal to or less than the last sound ray number L_{\max} (step S41: No), the frequency analysis unit 44 returns to step S32.

[0082] Accordingly, the frequency analysis unit 44 performs FFT calculation "K" times for each of $(L_{\max} - L_0 + 1)$ sound rays. The last sound ray number L_{\max} may be given to the last sound ray received by the transmitting and receiving unit 3 or given to a sound ray corresponding to any one of left and right boundaries of the region of interest, for example. Hereinafter, the total number of FFT calculations, $(L_{\max} - L_0 + 1) \times K$, which the frequency analysis unit 44 performs on all of the sound rays is denoted by "P".

[0083] Subsequently to the frequency analysis process of the above described step S11, the feature data extracting unit 45 extracts feature data of the frequency spectrum by approximating the frequency spectrum calculated by the frequency analysis unit 44 (steps S12 and S13).

[0084] First, at step S12, the approximation unit 451 extracts pre-correction feature data by performing regression analysis, as an approximation process, on "P" frequency spectra calculated by the frequency analysis unit 44. Specifically, by calculating a linear equation for approximating a frequency spectrum in a frequency band $f_{\text{LOW}} < f < f_{\text{HIGH}}$ by regression analysis, the approximation unit 451 extracts, as the pre-correction feature data, a gradient a_0 , an intercept b_0 , and an intensity c_0 that characterize the linear equation. The straight line L_1 illustrated in FIG. 13 and the straight line L_2 illustrated in FIG. 14 are regression lines acquired by performing regression analysis respectively on the frequency spectrum curves C_1 and C_2 in this step S12.

[0085] Thereafter, at step S13, the attenuation correction unit 452 calculates feature data by performing an attenuation correction process on the pre-correction feature data extracted by the approximation unit 451. For example, if a sampling frequency of data is 50 MHz, the sampling period is 20 (nsec). If a sound speed is 1530 (m/sec), a sampling distance interval of the data is $1530 \text{ (m/sec)} \times 20 \text{ (nsec)} / 2 = 0.0153 \text{ (mm)}$. If the number of data steps from the first data of the calculation echo signal LD(j) up to the data position of the FFT data group to be process is "k", that data position "Z" is $0.0153k \text{ (mm)}$. The attenuation correction unit 452 calculates a gradient "a", an intercept "b", and an intensity "c", which are feature data of the frequency spectrum, by substituting the value of the data position "Z" determined as described above into the receiving depth "z" of the above described equations (2) to (4). FIG. 15 is a diagram illustrating a straight line determined from feature data related to the straight line L_1 illustrated in FIG. 13, the feature data having been subjected to attenuation correction. An equation representing a straight line L_1' illustrated in FIG. 15 is as follows.

$$I = af + b = (a_0 + 2\alpha Z)f + b_0 \quad (5)$$

As is clear from this equation (5), the straight line L_1' has, as compared to the straight line L_1 , a greater gradient and the same value of intercept.

[0086] As described above, by performing the attenuation correction by the attenuation correction unit 452, decrease in a signal intensity and darkening of an image due to influence of attenuation in a region where the receiving depth is large are able to be suppressed, and an image of a brightness uniform over the whole screen is able to be acquired.

[0087] Subsequently to step S13, the display image data generation unit 52 generates display image data, by using the B-mode image data generated by the B-mode image data generation unit 51 and the feature data calculated by the feature data extracting unit 45 (step S14).

[0088] Thereafter, the display unit 7 displays a display image generated by the display image data generation unit 52 (step S15). FIG. 16 is a diagram illustrating a display example of a display image in the display unit 7. A display image 200 illustrated in the figure has an information display portion 201 that displays various types of information on a specimen; and an image display portion 202 that displays a tissue characterization highlighted image that highlights tissue characterization.

[0089] In the information display portion 201, for example, identification information of the specimen (ID number, name, sex, and the like), feature data information, ultrasonic image quality information such as a gain and a contrast, and the like are displayed. Display using, as feature data information, an average and a standard deviation of feature data of frequency spectra of "Q" FFT data groups positioned inside the region of interest is able to be performed. Specifically, in the information display portion, for example, "a = 1.5 ± 0.3 (dB/MHz), b = -60 ± 2 (dB/MHz), c = -50 ± 1.5 (dB/MHz)" may be displayed.

[0090] A tissue characterization highlighted image 300 displayed on the image display portion 202 is a gray scale image in which the feature data "b" has been uniformly allocated to red (R), green (G), and blue (B) for the B-mode image 100 illustrated in FIG. 6.

[0091] By the display unit 7 displaying the display image 200, a user of the ultrasonic observation apparatus 1 is able to more accurately grasp tissue characterization of a region of interest.

[0092] Accordingly, the ultrasonic observation apparatus 1 ends the series of processes. The ultrasonic observation apparatus 1 may periodically repeat the process of steps S1 to S15.

[0093] The tissue characterization highlighted image 300 illustrated in FIG. 16 is just an example. Instead, for example, the three feature data "a", "b", and "c" may be respectively allocated to red (R), green (G), and blue (B), to thereby display the tissue characterization highlighted image by a color image. In this case, since the tissue characterization is expressed by specific colors, the user is able to grasp the tissue characterization of the region of interest based on a color distribution of the image. Further, instead of forming the color space with the RGB color system, it may be formed by variables of a complementary color system, such as cyan, magenta, and yellow and the feature data may be allocated to each of the variables. Further, by mixing the B-mode image data and color image data in a specified ratio, the tissue characterization highlighted image data may be generated. Further, by substituting only the region of interest into color image data, the tissue characterization highlighted image data may be generated.

[0094] According to the above described first embodiment of the present invention, a plurality of focus points based on a size of a region of interest are calculated, and feature data are extracted by performing frequency analysis on an ultrasonic wave transmitted and received to and from each focus point, and thus tissue characterization is able to be accurately diagnosed and reliability of an observation result is able to be improved.

[0095] Further, according to the first embodiment, since positioning to a focus point is performed for each divided region, a phenomenon that a frequency spectrum other than the focus point is distorted due to influence of a transmission delay is able to be suppressed. Therefore, according to the first embodiment, highly accurate calculation of feature data of frequency is possible.

[0096] Further, according to the first embodiment, since B-mode image data are generated based on a signal subjected to STC correction of amplifying with an amplification factor according to a receiving depth, a frequency spectrum is calculated after performing amplification correction of offsetting influence of the STC correction and making the amplification factor constant regardless of the receiving depth, and attenuation correction is performed after this frequency spectrum is subjected to linear approximation by regression analysis, influence of attenuation associated with propagation of an ultrasonic wave is able to be removed correctly, and decrease in a frame rate of image data generated based on the received ultrasonic wave is able to be prevented.

[0097] FIG. 17 is a diagram illustrating another display example of a display image in the display unit 7. A display image 400 illustrated in the figure has: an information display portion 401; a first image display portion 402 that displays a B-mode image; and a second image display portion 403 that displays a tissue characterization highlighted image. In the display image 400, a B-mode image 100 is displayed on the first image display portion 402 and a tissue characterization highlighted image 300 is displayed on the second image display portion 403. By displaying the B-mode image and the tissue characterization highlighted image side by side like this, differences between these images are able to be recognized on a single screen.

[0098] In the display image 400, an image displayed on the first information display portion and an image displayed on the second image display portion 403 may be able to be switched over to each other.

[0099] Further, the display of the display image 200 and the display of the display image 400 may be switched over to each other by input from the input unit 6.

(Second Embodiment)

[0100] In a second embodiment of the present invention, a focus point calculation process in a focus point calculation unit is different from that of the first embodiment. A configuration of an ultrasonic observation apparatus according to the second embodiment is similar to the configuration of the ultrasonic observation apparatus 1 described in the first embodiment. Thus, in the description below, to structural elements corresponding to the structural elements of the ultrasonic observation apparatus 1, the same reference signs will be appended.

[0101] FIG. 18 is a diagram schematically illustrating an outline of a focus point calculation process in the second embodiment. In FIG. 18, the number of transmissions for one sound ray is i_{\max} . Further, a region of interest RB illustrated in FIG. 18 is divided into i_{\max} partial regions of interest RB(1), ..., RB(i_{\max}).

[0102] The focus point calculation unit 42 calculates specified data positions "Z" respectively representing a plurality of FFT data groups acquired on sound rays by the frequency analysis unit 44 as focus points FP(j)(j = 1, 2, ..., i_{\max}) of their corresponding partial regions of interest, and determines the number of transmissions per sound ray and a transmission timing of a calculation echo signal.

[0103] According to the above described second embodiment of the present invention, similarly to the above described first embodiment, accurate diagnosis of tissue characterization is enabled and reliability of a measurement result is able to be improved.

[0104] Further, according to the second embodiment, similarly to the above described first embodiment, by suppressing

a phenomenon that a frequency spectrum other than focus points is distorted due to influence of a transmission delay, highly accurate calculation of feature data of frequency is possible.

(Third Embodiment)

5
[0105] In a third embodiment of the present invention, a focus point calculation process in a focus point calculation unit is different from that of the first embodiment. A configuration of an ultrasonic observation apparatus according to the third embodiment is similar to the configuration of the ultrasonic observation apparatus 1 described in the first embodiment. Thus, in the description below, to structural elements corresponding to the structural elements of the ultrasonic observation apparatus 1, the same reference signs will be appended.

10
[0106] FIG. 19 is a diagram schematically illustrating an outline of the focus point calculation process in the third embodiment. In FIG. 19, the number of transmissions for one sound ray is i_{max} . Further, a region of interest RB illustrated in FIG. 19 is divided into i_{max} partial regions of interest RC(1), ..., RC(i_{max}).

15
[0107] In the third embodiment, if a focus point of a B-mode image echo signal is included in the region of interest, the focus point calculation unit 42 does not perform setting of a focus point of a calculation echo signal for a partial region of interest including the focus point of the B-mode image echo signal. The frequency analysis unit 44 acquires, by using the B-mode image echo signal, an FFT data group in a partial region of interest for which a focus point of the calculation echo signal has not been set.

20
[0108] For example, in a case illustrated in FIG. 19, for a partial region of interest RC(2), a focus point FP(B) of a B-mode image echo signal LD(B) is set. Thus, for the partial region of interest RC(2), the transmitting and receiving unit 3 does not set a focus point in any of calculation echo signals LD(1) to LD(i_{max}). The frequency analysis unit 44 acquires an FFT data group in the partial region of interest RC(2) from the B-mode image echo signal LD(B).

25
[0109] According to the above described third embodiment of the present invention, similarly to the above described first embodiment, accurate diagnosis of tissue characterization is enabled and reliability of a measurement result is able to be improved.

[0110] Further, according to the third embodiment, similarly to the above described first embodiment, by suppressing a phenomenon that a frequency spectrum other than focus points is distorted due to influence of a transmission delay, highly accurate calculation of feature data of frequency is possible.

30
[0111] Thus far, modes for carrying out the present invention have been described, but the present invention is not to be limited only by the above described first to third embodiments. For example the number of ultrasonic transmissions per sound ray may be decreased according to calculation load situations.

[0112] Further, when the feature data of the frequency spectrum are extracted, after applying attenuation correction on the frequency spectrum calculated by the frequency analysis unit, the corrected frequency spectrum may be approximated by regression analysis.

35
[0113] Further, the control unit 9 may cause the amplification correction process by the amplification correction unit 43 and the attenuation correction process in the attenuation correction unit 452 to be performed collectively. This is equivalent to changing the definition of the attenuation amount "A" of the attenuation correction process in step S13 of FIG. 5 to Equation (6) below without performing the amplification correction process in step S6 of FIG. 5.

40

$$A' = 2\alpha z f + \gamma(z) \tag{6}$$

Here, $\gamma(z)$ on the right hand side is a difference between amplification factors β and β_0 at the receiving depth "z" and is expressed as follows.

45

$$\gamma(z) = -\{(\beta_{th} - \beta_0)/z_{th}\}z + \beta_{th} - \beta_0 \quad (z \leq z_{th}) \tag{7}$$

50

$$\gamma(z) = 0 \quad (z > z_{th}) \tag{8}$$

Reference Signs List

- 55
[0114]
 1 ultrasonic observation apparatus
 2 ultrasonic probe

	3 transmitting and receiving unit
	4 calculation unit
	5 image processing unit
	6 input unit
5	7 display unit
	8 storage unit
	9 control unit
	21 signal converter
	22 ultrasonic transducer
10	31 signal amplification unit
	41 region of interest setting unit
	42 focus point calculation unit
	43 amplification correction unit
	44 frequency analysis unit
15	45 feature data extracting unit
	51 B-mode image data generation unit
	52 display image data generation unit
	81 focus point information storage unit
	82 amplification factor information storage unit
20	83 window function storage unit
	84 correction information storage unit
	100 B-mode image
	200, 400 display image
	201, 401 information display portion
25	202 image display portion
	300 tissue characterization highlighted image
	402 first image display portion
	403 second image display portion
	451 approximation unit
30	452 attenuation correction unit
	FP (j) (j=1, ..., i _{max}), FP(B) focus point
	RA, RB, RC region of interest
	RA(j), RB(j), RC(j) (j=1, ..., i _{max}) partial region of interest
	SF1, SF2, SF3 sound field
35	Tb focus point information table

Claims

- 40 **1.** An ultrasonic observation apparatus (1) that is adapted to transmit an ultrasonic wave to a specimen and receive the ultrasonic wave reflected from the specimen, the ultrasonic observation apparatus (1) comprising:
- 45 a region of interest setting unit (41) that is able to set information on a position, and a size in a depth direction, of a region of interest in the specimen;
- a focus point calculation unit (42) that is adapted to divide the region of interest into a plurality of partial regions of interest according to the number of focus points in the region of interest, the number of focus points being a parameter associated with size information of the region of interest set by the region of interest setting unit (41), calculate a focus point in each of the partial regions of interest, and determine a transmission timing according to the calculated focus point;
- 50 a transmitting and receiving unit (3) that is adapted to perform a transmission-and-reception of an ultrasonic wave on a sound ray in the region of interest as many times as the number of focus points on the sound ray, the transmission-and-reception of the ultrasonic wave being focused on the focus point calculated by the focus point calculation unit (42);
- a frequency analysis unit (44) that is adapted to calculate a plurality of frequency spectra by analyzing the ultrasonic wave received by the transmitting and receiving unit (3) with reference to the focus points;
- 55 a feature data extracting unit (45) that is adapted to extract feature data of the frequency spectra calculated by the frequency analysis unit (44) by approximating the frequency spectra, said spectrum being correlated with a tissue characteristic for tissue differentiation;

an image processing unit (5) that is adapted to generate ultrasonic image data having a display mode corresponding to the feature data extracted by the feature data extracting unit (45); and a B-mode image data generation unit (51) that is adapted to generate B-mode image data for displaying brightness converted from amplitude of the ultrasonic wave reflected from the specimen,
 wherein the focus point calculation unit (42) is adapted to set a focus point for the B-mode image, and is adapted not to set the B-mode focus point according to the number of focus points in the partial regions of interest including the focus point for the B-mode image, and wherein the transmitting and receiving unit (3) is adapted to perform the transmission-and-reception of the ultrasonic wave which is focused on the focus point set for a B-mode image.

2. The ultrasonic observation apparatus (1) according to claim 1, wherein the frequency analysis unit (44) is adapted to calculate the frequency spectra by acquiring a data group forming a part of a data array of the ultrasonic wave received by the transmitting and receiving unit (3) and by performing fast Fourier transform on the data group.
3. The ultrasonic observation apparatus (1) according to claim 2, wherein the frequency analysis unit (44) is adapted to acquire the data group from a plurality of ultrasonic waves transmitted and received for one sound ray by using an ultrasonic wave in which a closest focus point exists on the sound ray.
4. The ultrasonic observation apparatus (1) according to claim 1, wherein the focus point calculation unit (42) is adapted to calculate, as the focus point, a central position of each of the partial regions of interest in a depth direction.
5. The ultrasonic observation apparatus (1) according to claim 1, wherein the focus point calculation unit (42) is adapted to calculate, as the focus point, a center of a data array in a depth direction in each of the partial regions of interest.
6. The ultrasonic observation apparatus (1) according to claim 2, wherein the focus point calculation unit (42) is adapted to calculate, as the focus point, a specified data position in the data group.
7. The ultrasonic observation apparatus (1) according to claim 1, further comprising a display unit (7) that is able to display an image corresponding to the ultrasonic image data generated by the image processing unit (5).
8. An operation method of an ultrasonic observation apparatus (1) that transmits an ultrasonic wave to a specimen and receives the ultrasonic wave reflected from the specimen, the operation method comprising:

a region-of-interest setting step of setting a position, and size in a depth direction, of a region of interest in the specimen;
 a focus point calculating step of dividing the region of interest into a plurality of partial regions of interest according to the number of focus points in the region of interest, the number of focus points being a parameter associated with size information of the region of interest set at the region-of-interest setting step, and calculating a focus point in each of the partial regions of interest;
 a determination step of determining a transmission timing according to the calculated focus point;
 a transmitting and receiving step of performing a transmission-and-reception of an ultrasonic wave on a sound ray in the region of interest as many times as the number of focus points on the sound ray, the transmission-and-reception of the ultrasonic wave being focused on the focus point calculated at the focus point calculating step;
 a frequency analysis step of calculating a plurality of frequency spectra by analyzing the ultrasonic wave received at the transmitting and receiving step with reference to the focus points;
 a feature data extracting step of extracting feature data of the frequency spectra by approximating the frequency spectra calculated at the frequency analysis step, said spectrum being correlated with a tissue characteristic for tissue differentiation;
 an image processing step of generating ultrasonic image data having a display mode corresponding to the feature data extracted at the feature data extracting step; and
 a B-mode image data generation step of generating B-mode image data for displaying brightness converted from amplitude of the ultrasonic wave reflected from the specimen,
 wherein the focus point calculating step includes setting a focus point for the B-mode image, and not setting the B-mode focus point according to the number of focus points in the partial regions of interest including the focus point for the B-mode image, and wherein the transmitting and receiving step performs the transmission-and-reception of the ultrasonic wave which is focused on the focus point set for a B-mode image.

9. An operation program of an ultrasonic observation apparatus (1) that transmits an ultrasonic wave to a specimen and receives the ultrasonic wave reflected from the specimen, the program instructing the ultrasonic observation apparatus (1) to execute:

5 a region-of-interest setting step of setting a position, and size in a depth direction, of a region of interest in the specimen;
a focus point calculating step of dividing the region of interest into a plurality of partial regions of interest according to the number of focus points in the region of interest, the number of focus points being a parameter associated with size information of the region of interest set at the region-of-interest setting step, and calculating a focus point in each of the partial regions of interest;
10 a determination step of determining a transmission timing according to the calculated focus point;
a transmitting and receiving step of performing a transmission-and-reception of an ultrasonic wave on a sound ray in the region of interest as many times as the number of focus points on the sound ray, the transmission-and-reception of the ultrasonic wave being focused on the focus point calculated at the focus point calculating step;
15 a frequency analysis step of calculating a plurality of frequency spectra by analyzing the ultrasonic wave received at the transmitting and receiving step with reference to the focus points;
a feature data extracting step of extracting feature data of the frequency spectra by approximating the frequency spectra calculated at the frequency analysis step, said spectrum being correlated with a tissue characteristic for tissue differentiation;
20 an image processing step of generating ultrasonic image data having a display mode corresponding to the feature data extracted at the feature data extracting step; and
a B-mode image data generation step of generating B-mode image data for displaying brightness converted from amplitude of the ultrasonic wave reflected from the specimen,
25 wherein the focus point calculating step includes setting a focus point for the B-mode image, and not setting the B-mode focus point according to the number of focus points in the partial regions of interest including the focus point for the B-mode image, and wherein the transmitting and receiving step performs the transmission-and-reception of the ultrasonic wave which is focused on the focus point set for a B-mode image.

30

Patentansprüche

1. Ultraschallbeobachtungsapparat (1), welcher eingerichtet ist, um eine Ultraschallwelle an eine Probe zu senden und die Ultraschallwelle, welche von der Probe reflektiert wurde, zu empfangen, wobei der Ultraschallbeobachtungsapparat (1) umfasst:

35

eine Interessensgebietfestlegungseinheit (41), welche in der Lage ist, Information über eine Position und eine Größe in einer Tiefenrichtung eines Interessengebiets in der Probe festzulegen;
eine Fokalkpunktberechnungseinheit (42), welche eingerichtet ist, um das Interessensgebiet in eine Vielzahl von partiellen Interessensgebieten entsprechend der Anzahl von Fokalkpunkten in dem Interessensgebiet zu unterteilen, wobei die Anzahl von Fokalkpunkten ein Parameter ist, der mit Größeninformation des Interessensgebiets, welches durch die Interessensgebietfestlegungseinheit (41) festgelegt wurde, assoziiert wurde, um einen Fokalkpunkt in jedem der partiellen Interessensgebieten zu berechnen und um eine Sendezeitvorgabe entsprechend dem berechneten Fokalkpunkt zu bestimmen;
40 eine Sende- und Empfangseinheit (3), welche eingerichtet ist, um ein Senden-und-Empfangen einer Ultraschallwelle auf einem Schallstrahl in dem Interessensgebiet so viele Male wie die Anzahl von Fokalkpunkten auf dem Schallstrahl auszuführen, wobei das Senden-und-Empfangen der Ultraschallwelle auf den Fokalkpunkt, welcher durch die Fokalkpunktberechnungseinheit (42) berechnet wurde, fokussiert ist;
eine Frequenzanalyseeinheit (44), welche eingerichtet ist, um eine Vielzahl von Frequenzspektren durch Analysieren der Ultraschallwelle, welche durch die Sende- und Empfangseinheit (3) empfangen wurde, mit Bezug auf die Fokalkpunkte zu berechnen;
45 eine Merkmalsdatenextraktionseinheit (45), welche eingerichtet ist, um Merkmalsdaten der Frequenzspektren, welche durch die Frequenzanalyseeinheit (44) durch Approximieren der Frequenzspektren berechnet wurden, zu extrahieren, wobei das Spektrum mit einer Gewebebecharakteristik für Gewebeunterscheidung korreliert ist;
50 eine Bildverarbeitungseinheit (5), welche eingerichtet ist, um Ultraschallbilddaten, die einen Anzeigemodus aufweisen, der den Merkmalsdaten entspricht, welche durch die Merkmalsdatenextraktionseinheit (45) extrahiert wurden, zu erzeugen; und
eine B-mode-Bilddatenerzeugungseinheit (51), welche eingerichtet ist, um B-mode-Bilddaten zum Anzeigen

55

von Helligkeit, welche von der Amplitude der Ultraschallwelle, welche von der Probe reflektiert wurde, zu erzeugen,

wobei die Fokalkpunktberechnungseinheit (42) eingerichtet ist, um einen Fokalkpunkt für das B-mode-Bild festzulegen, und eingerichtet ist, um nicht den B-mode-Fokalkpunkt entsprechend der Anzahl von Fokalkpunkten in den partiellen Interessensgebieten enthaltend den Fokalkpunkt für das B-mode-Bild festzulegen, und wobei die Sende- und Empfangseinheit (3) eingerichtet ist, um das Senden-und-Empfangen der Ultraschallwelle, welche auf den für das B-mode-Bild festgelegten Fokalkpunkt fokussiert ist, auszuführen.

2. Ultraschallbeobachtungsapparat (1) gemäß Anspruch 1, wobei die Frequenzanalyseeinheit (44) eingerichtet ist, um die Frequenzspektren durch Erlangen einer Datengruppe bildend einen Teil einer Datenreihe der Ultraschallwelle, welche von der Sende- und Empfangseinheit (3) empfangen wurde, und durch Ausführen von schneller Fourier Transformation auf der Datengruppe, zu berechnen.

3. Ultraschallbeobachtungsapparat (1) gemäß Anspruch 2, wobei die Frequenzanalyseeinheit (44) eingerichtet ist, um die Datengruppe von einer Vielzahl von Ultraschallwellen, welche für einen Schallstrahl durch Nutzung einer Ultraschallwelle, in welcher ein nächster Fokalkpunkt auf dem Schallstrahl existiert, gesendet und empfangen wurden, zu erlangen.

4. Ultraschallbeobachtungsapparat (1) gemäß Anspruch 1, wobei die Fokalkpunktberechnungseinheit (42) eingerichtet ist, um als den Fokalkpunkt eine Zentralposition von jedem der partiellen Interessensgebiete in einer Tiefenrichtung zu berechnen.

5. Ultraschallbeobachtungsapparat (1) gemäß Anspruch 1, wobei die Fokalkpunktberechnungseinheit (42) eingerichtet ist, um als den Fokalkpunkt einen Mittelpunkt einer Datenreihe in einer Tiefenrichtung in jedem der partiellen Interessensgebiete zu berechnen

6. Ultraschallbeobachtungsapparat (1) gemäß Anspruch 2, wobei die Fokalkpunktberechnungseinheit (42) eingerichtet ist, um als den Fokalkpunkt eine bestimmte Datenposition in der Datengruppe zu berechnen.

7. Ultraschallbeobachtungsapparat (1) gemäß Anspruch 1, des Weiteren umfassend eine Anzeigeeinheit (7), welche in der Lage ist, ein Bild entsprechend den Ultraschallbilddaten, welche durch die Bildverarbeitungseinheit (5) erzeugt wurden, anzuzeigen.

8. Betätigungsverfahren für einen Ultraschallbeobachtungapparat (1), welcher eine Ultraschallwelle zu einer Probe sendet und die Ultraschallwelle, welche von der Probe reflektiert wurde, empfängt, wobei das Betätigungsverfahren umfasst:

einen Interessensgebietfestlegungsschritt eines Festlegens einer Position und Größe in einer Tiefenrichtung eines Interessensgebiets in der Probe;

einen Fokalkpunktberechnungsschritt eines Unterteilens des Interessensgebiets in eine Vielzahl von partiellen Interessensgebieten entsprechend der Anzahl von Fokalkpunkten in dem Interessensgebiet, wobei die Anzahl von Fokalkpunkten ein Parameter ist, der mit Größeninformation des Interessensgebiets, welcher in dem Interessensgebietfestlegungsschritt festgelegt wurde, assoziiert wurde, und eines Berechnens eines Fokalkpunkts in jedem der partiellen Interessensgebiete;

einen Bestimmungsschritt eines Bestimmens einer Sendezeitvorgabe entsprechend den berechneten Fokalkpunkten;

einen Sende- und Empfangsschritt eines Ausführens eines Sende-und-Empfangs einer Ultraschallwelle auf einem Schallstrahl in dem Interessensgebiet so viele Male wie die Anzahl von Fokalkpunkten auf dem Schallstrahl, wobei das Senden-und-Empfangen der Ultraschallwelle auf den Fokalkpunkt, welcher in dem Fokalkpunktberechnungsschritt berechnet wurde, fokussiert ist;

einen Frequenzanalyseschritt eines Berechnens einer Vielzahl von Frequenzspektren durch Analysieren der Ultraschallwelle, welche in dem Sende- und Empfangsschritt empfangen wurde, mit Bezug auf die Fokalkpunkte; einen Merkmalsdatenextraktionsschritt eines Extrahierens von Merkmalsdaten der Frequenzspektren durch Approximieren der in dem Frequenzanalyseschritt berechneten Frequenzspektren, wobei das Spektrum mit einer Gewebecharakteristik für Gewebeunterscheidung korreliert ist

einen Bildverarbeitungsschritt eines Erzeugens von Ultraschallbilddaten, die einen Anzeigemodus aufweisen, der den Merkmalsdaten entspricht, welche in dem Merkmalsdatenextraktionsschritt extrahiert wurden; und einen B-mode-Bilddatenerzeugungsschritt eines Erzeugens von B-mode-Bilddaten zum Anzeigen von Hellig-

keit, welche von der Amplitude der Ultraschallwelle, welche von der Probe reflektiert wurde, zu erzeugen, wobei der Fokalkpunktberechnungsschritt Festlegen eines Fokalkpunkts für das B-mode-Bild, und nicht Festlegen des B-mode-Fokalkpunkts entsprechend der Anzahl von Fokalkpunkten in den partiellen Interessensgebieten enthaltend den Fokalkpunkt für das B-mode-Bild enthält, und wobei der Sende- und Empfangsschritt das Senden- und Empfangen der Ultraschallwelle, welche auf den für das B-mode-Bild festgelegten Fokalkpunkt fokussiert ist, auszuführen.

9. Betätigungsprogramm für einen Ultraschallbeobachtungsapparat (1), welcher eine Ultraschallwelle zu einer Probe sendet und die Ultraschallwelle, welche von der Probe reflektiert wurde, empfängt, wobei das Programm den Ultraschallbeobachtungsapparat (1) anweist, auszuführen:

einen Interessensgebietfestlegungsschritt eines Festlegens einer Position und Größe in einer Tiefenrichtung eines Interessensgebiets in der Probe;

einen Fokalkpunktberechnungsschritt eines Unterteilens des Interessensgebiets in eine Vielzahl von partiellen Interessensgebieten entsprechend der Anzahl von Fokalkpunkten in dem Interessensgebiet, wobei die Anzahl von Fokalkpunkten ein Parameter ist, der mit Größeninformation des Interessensgebiets, welcher in dem Interessensgebietfestlegungsschritt festgelegt wurde, assoziiert wurde, und eines Berechnens eines Fokalkpunkts in jedem der partiellen Interessensgebiete;

einen Bestimmungsschritt eines Bestimmens einer Sendezeitvorgabe entsprechend den berechneten Fokalkpunkten;

einen Sende- und Empfangsschritt eines Ausführens eines Sende- und Empfangs einer Ultraschallwelle auf einem Schallstrahl in dem Interessensgebiet so viele Male wie die Anzahl von Fokalkpunkten auf dem Schallstrahl, wobei das Senden- und Empfangen der Ultraschallwelle auf den Fokalkpunkt, welcher in dem Fokalkpunktberechnungsschritt berechnet wurde, fokussiert ist;

einen Frequenzanalyseschritt eines Berechnens einer Vielzahl von Frequenzspektren durch Analysieren der Ultraschallwelle, welche in dem Sende- und Empfangsschritt empfangen wurde, mit Bezug auf die Fokalkpunkte; einen Merkmalsdatenextraktionsschritt eines Extrahierens von Merkmalsdaten der Frequenzspektren durch Approximieren der in dem Frequenzanalyseschritt berechneten Frequenzspektren, wobei das Spektrum mit einer Gewebecharakteristik für Gewebeunterscheidung korreliert ist

einen Bildverarbeitungsschritt eines Erzeugens von Ultraschallbilddaten, die einen Anzeigemodus aufweisen, der den Merkmalsdaten entspricht, welche in dem Merkmalsdatenextraktionsschritt extrahiert wurden; und einen B-mode-Bilddatenerzeugungsschritt eines Erzeugens von B-mode-Bilddaten zum Anzeigen von Helligkeit, welche von der Amplitude der Ultraschallwelle, welche von der Probe reflektiert wurde, zu erzeugen,

wobei der Fokalkpunktberechnungsschritt Festlegen eines Fokalkpunkts für das B-mode-Bild, und nicht Festlegen des B-mode-Fokalkpunkts entsprechend der Anzahl von Fokalkpunkten in den partiellen Interessensgebieten enthaltend den Fokalkpunkt für das B-mode-Bild enthält, und wobei der Sende- und Empfangsschritt das Senden- und Empfangen der Ultraschallwelle, welche auf den für das B-mode-Bild festgelegten Fokalkpunkt fokussiert ist, ausführt.

Revendications

1. Appareil (1) d'observation par ultrasons qui est adapté à transmettre une onde ultrasonore jusqu'à un spécimen et recevoir l'onde ultrasonore réfléchiée depuis le spécimen, l'appareil (1) d'observation par ultrasons comprenant :

une unité (41) de définition de région d'intérêt qui est apte à définir des informations sur une position, et une taille dans un sens de la profondeur, d'une région d'intérêt dans le spécimen ;

une unité (42) de calcul de points focaux qui est adaptée à diviser la région d'intérêt en une pluralité de régions partielles d'intérêt en fonction du nombre de points focaux dans la région d'intérêt, le nombre de points focaux étant un paramètre associé avec une information de taille de la région d'intérêt définie par l'unité (41) de définition de région d'intérêt, calculer un point focal dans chacune des régions partielles d'intérêt, et déterminer une synchronisation de transmission en fonction du point focal calculé ;

une unité (3) de transmission et de réception qui est adaptée à effectuer une transmission et une réception d'une onde ultrasonore sur un rayon sonore dans la région d'intérêt un nombre de fois égal au nombre de points focaux sur le rayon sonore, la transmission et la réception de l'onde ultrasonore étant focalisées sur le point focal calculé par l'unité (42) de calcul de points focaux ;

une unité (44) d'analyse de fréquences qui est adaptée à calculer une pluralité de spectres de fréquences en

analysant l'onde ultrasonore reçue par l'unité (3) de transmission et de réception en référence aux points focaux ;
 une unité (45) d'extraction de données de caractéristiques qui est adaptée à extraire des données de caractéristiques des spectres de fréquences calculés par l'unité (44) d'analyse de fréquences par approche des spectres de fréquences, ledit spectre étant corrélé avec une caractéristique de tissu pour une différenciation de tissus ;

une unité (5) de traitement d'images qui est adaptée à générer des données d'images ultrasonores ayant un mode d'affichage correspondant aux données de caractéristiques extraites par l'unité (45) d'extraction de données de caractéristiques ; et

une unité (51) de génération de données d'images en mode B qui est adaptée à générer des données d'images en mode B pour afficher une luminosité convertie à partir d'une amplitude de l'onde ultrasonore réfléchie depuis le spécimen,
 dans lequel l'unité (42) de calcul de points focaux est adapté à définir un point focal pour l'image en mode B, et est adaptée à ne pas définir le point focal en mode B en fonction du nombre de points focaux dans les régions partielles d'intérêt incluant le point focal pour l'image en mode B, et dans lequel l'unité (3) de transmission et de réception est adaptée à effectuer la transmission et la réception de l'onde ultrasonore qui est focalisée sur le point focal défini pour une image en mode B.

2. Appareil (1) d'observation par ultrasons selon la revendication 1, dans lequel l'unité (44) d'analyse de fréquences est adaptée à calculer les spectres de fréquences en acquérant un groupe de données formant une partie d'un ensemble de données de l'onde ultrasonore reçue par l'unité (3) de transmission et de réception et en effectuant une transformée de Fourier rapide sur le groupe de données.

3. Appareil (1) d'observation par ultrasons selon la revendication 2, dans lequel l'unité (44) d'analyse de fréquences est adaptée à acquérir le groupe de données parmi une pluralité d'ondes ultrasonores transmises et reçues pour un rayon sonore en utilisant une onde ultrasonore dans laquelle un point focal le plus proche existe sur le rayon sonore.

4. Appareil (1) d'observation par ultrasons selon la revendication 1, dans lequel l'unité (42) de calcul de points focaux est adaptée à calculer, comme le point focal, une position centrale de chacune des régions partielles d'intérêt dans un sens de la profondeur.

5. Appareil (1) d'observation par ultrasons selon la revendication 1, dans lequel l'unité (42) de calcul de points focaux est adaptée à calculer, comme le point focal, un centre d'un ensemble de données dans un sens de la profondeur dans chacune des régions partielles d'intérêt.

6. Appareil (1) d'observation par ultrasons selon la revendication 2, dans lequel l'unité (42) de calcul de points focaux est adaptée à calculer, comme le point focal, une position de données spécifiée dans le groupe de données.

7. Appareil (1) d'observation par ultrasons selon la revendication 1, comprenant en outre une unité (7) d'affichage qui est apte à afficher une image correspondant aux données d'images ultrasonores générées par l'unité (5) de traitement d'images.

8. Procédé de fonctionnement d'un appareil (1) d'observation par ultrasons qui transmet une onde ultrasonore jusqu'à un spécimen et reçoit l'onde ultrasonore réfléchie depuis le spécimen, le procédé de fonctionnement comprenant :

une étape de définition de région d'intérêt pour définir une position, et une taille dans un sens de la profondeur, d'une région d'intérêt dans le spécimen ;

une étape de calcul de points focaux pour diviser la région d'intérêt en une pluralité de régions partielles d'intérêt en fonction du nombre de points focaux dans la région d'intérêt, le nombre de points focaux étant un paramètre associé avec une information de taille de la région d'intérêt définie à l'étape de définition de région d'intérêt, et calculer un point focal dans chacune des régions partielles d'intérêt ;

une étape de détermination pour déterminer une synchronisation de transmission en fonction du point focal calculé ;

une étape de transmission et de réception pour effectuer une transmission et une réception d'une onde ultrasonore sur un rayon sonore dans la région d'intérêt un nombre de fois égal au nombre de points focaux sur le rayon sonore, la transmission et la réception de l'onde ultrasonore étant focalisées sur le point focal calculé à l'étape de calcul de points focaux ;

une étape d'analyse de fréquences pour calculer une pluralité de spectres de fréquences en analysant l'onde ultrasonore reçue à l'étape de transmission et de réception en référence aux points focaux ;

une étape d'extraction de données de caractéristiques pour extraire des données de caractéristiques des

EP 2 904 975 B1

spectres de fréquences par approche des spectres de fréquences calculés à l'étape d'analyse de fréquences, ledit spectre étant corrélé avec une caractéristique de tissu pour une différenciation de tissus ;

une étape de traitement d'images pour générer des données d'images ultrasonores ayant un mode d'affichage correspondant aux données de caractéristiques extraites à l'étape d'extraction de données de caractéristiques ;
5 et

une étape de génération de données d'images en mode B pour générer des données d'images en mode B pour afficher une luminosité convertie à partir d'une amplitude de l'onde ultrasonore réfléchie depuis le spécimen, dans lequel l'étape de calcul de points focaux inclut la définition d'un point focal pour l'image en mode B, et la non définition du point focal en mode B en fonction du nombre de points focaux dans les régions partielles d'intérêt incluant le point focal pour l'image en mode B, et dans lequel l'étape de transmission et de réception effectuée la transmission et la réception de l'onde ultrasonore qui est focalisée sur le point focal défini pour une image en mode B.
10

9. Programme de fonctionnement d'un appareil (1) d'observation par ultrasons qui transmet une onde ultrasonore jusqu'à un spécimen et reçoit l'onde ultrasonore réfléchie depuis le spécimen, le programme donnant à l'appareil (1) d'observation par ultrasons la consigne d'exécuter :
15

une étape de définition de région d'intérêt pour définir une position, et une taille dans un sens de la profondeur, d'une région d'intérêt dans le spécimen ;
20

une étape de calcul de points focaux pour diviser la région d'intérêt en une pluralité de régions partielles d'intérêt en fonction du nombre de points focaux dans la région d'intérêt, le nombre de points focaux étant un paramètre associé avec une information de taille de la région d'intérêt définie à l'étape de définition de région d'intérêt, et calculer un point focal dans chacune des régions partielles d'intérêt ;

une étape de détermination pour déterminer une synchronisation de transmission en fonction du point focal calculé ;
25

une étape de transmission et de réception pour effectuer une transmission et une réception d'une onde ultrasonore sur un rayon sonore dans la région d'intérêt un nombre de fois égal au nombre de points focaux sur le rayon sonore, la transmission et la réception de l'onde ultrasonore étant focalisées sur le point focal calculé à l'étape de calcul de points focaux ;
30

une étape d'analyse de fréquences pour calculer une pluralité de spectres de fréquences en analysant l'onde ultrasonore reçue à l'étape de transmission et de réception en référence aux points focaux ;

une étape d'extraction de données de caractéristiques pour extraire des données de caractéristiques des spectres de fréquences par approche des spectres de fréquences calculés à l'étape d'analyse de fréquences, ledit spectre étant corrélé avec une caractéristique de tissu pour une différenciation de tissus ;
35

une étape de traitement d'images pour générer des données d'images ultrasonores ayant un mode d'affichage correspondant aux données de caractéristiques extraites à l'étape d'extraction de données de caractéristiques ;
40 et

une étape de génération de données d'images en mode B pour générer des données d'images en mode B pour afficher une luminosité convertie à partir d'une amplitude de l'onde ultrasonore réfléchie depuis le spécimen, dans lequel l'étape de calcul de points focaux inclut la définition d'un point focal pour l'image en mode B, et la non définition du point focal en mode B en fonction du nombre de points focaux dans les régions partielles d'intérêt incluant le point focal pour l'image en mode B, et dans lequel l'étape de transmission et de réception effectuée la transmission et la réception de l'onde ultrasonore qui est focalisée sur le point focal défini pour une image en mode B.
45

50

55

55

FIG.1

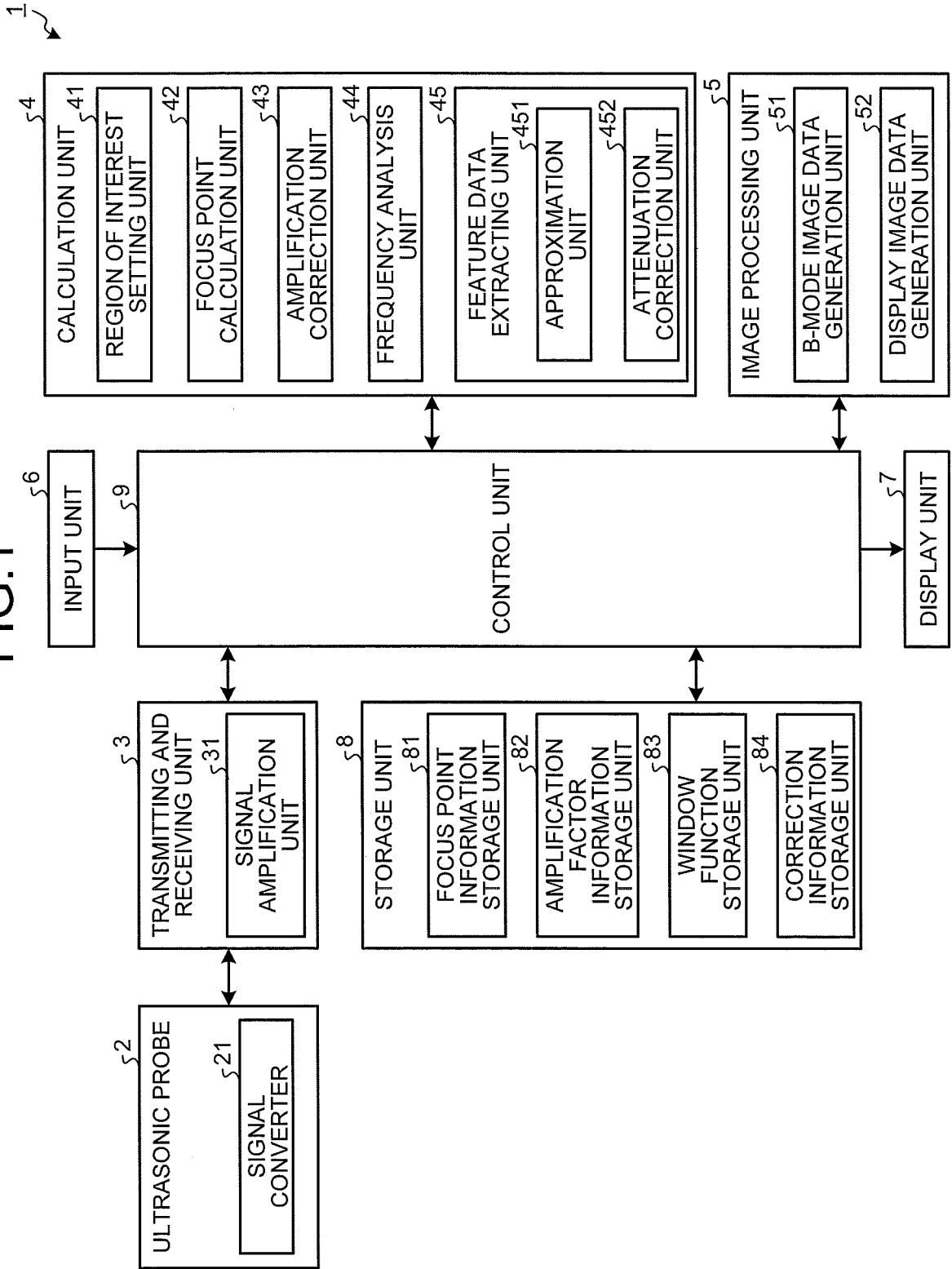

FIG.2

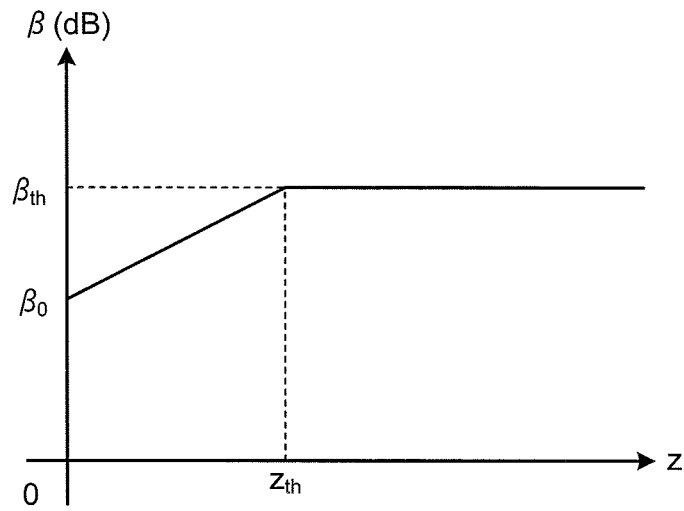

FIG.3

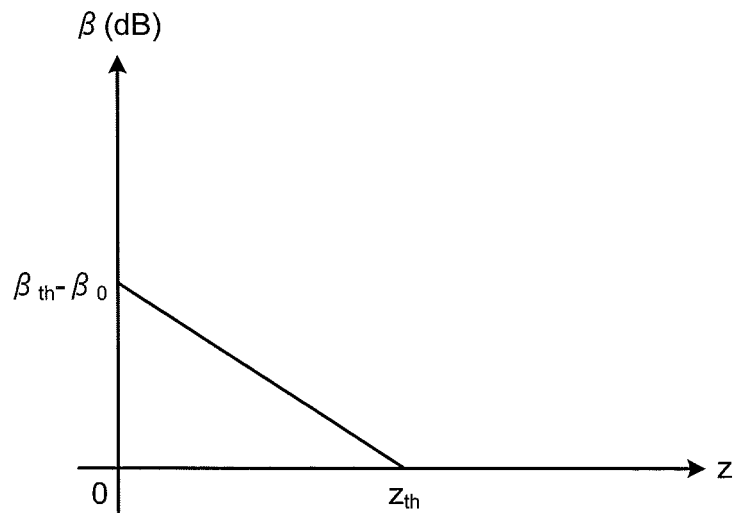

FIG.4

ζ Tb

SIZE OF REGION OF INTEREST IN DEPTH DIRECTION w (cm)	NUMBER OF FOCUS POINTS
1	1
2	1
3	2
4	3
5	3

FIG.5

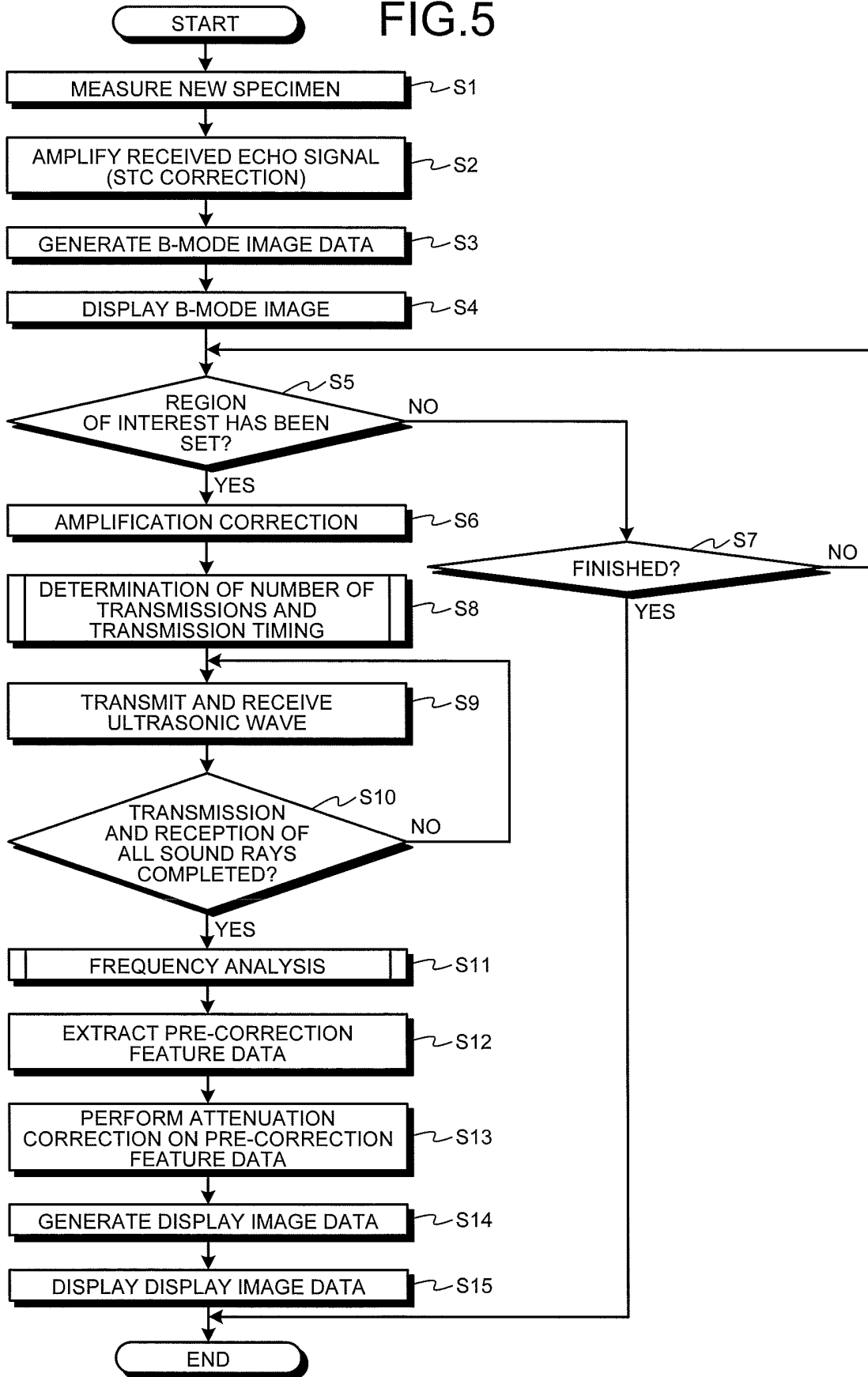

FIG.6

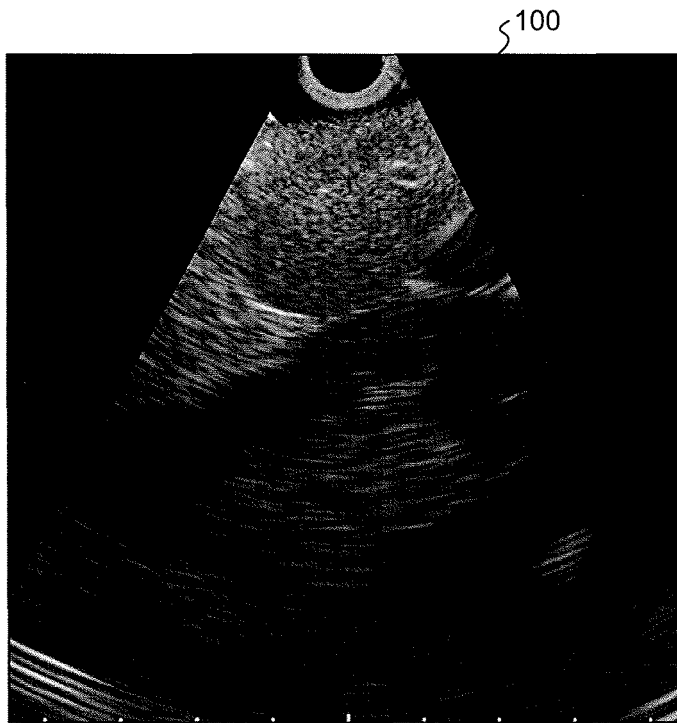

FIG.7

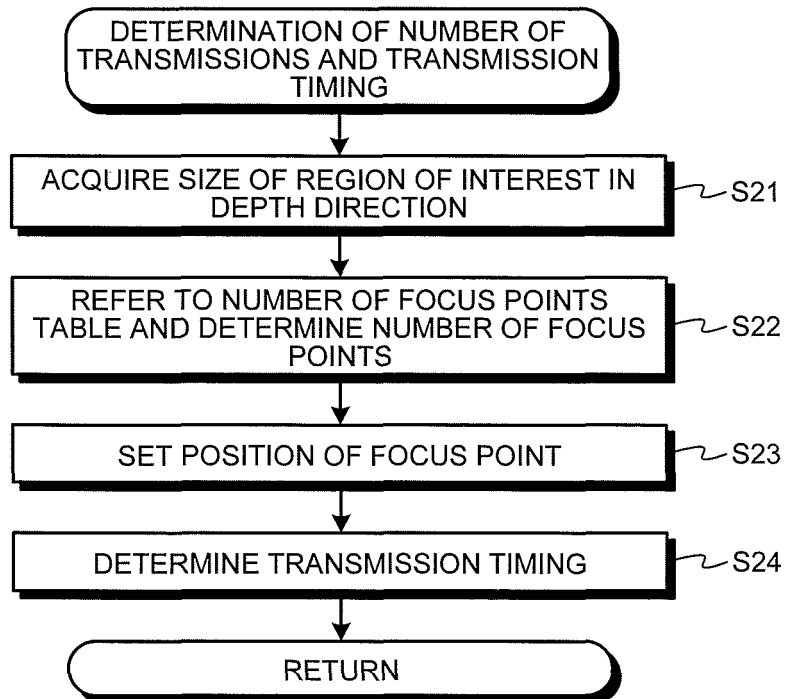

FIG.8

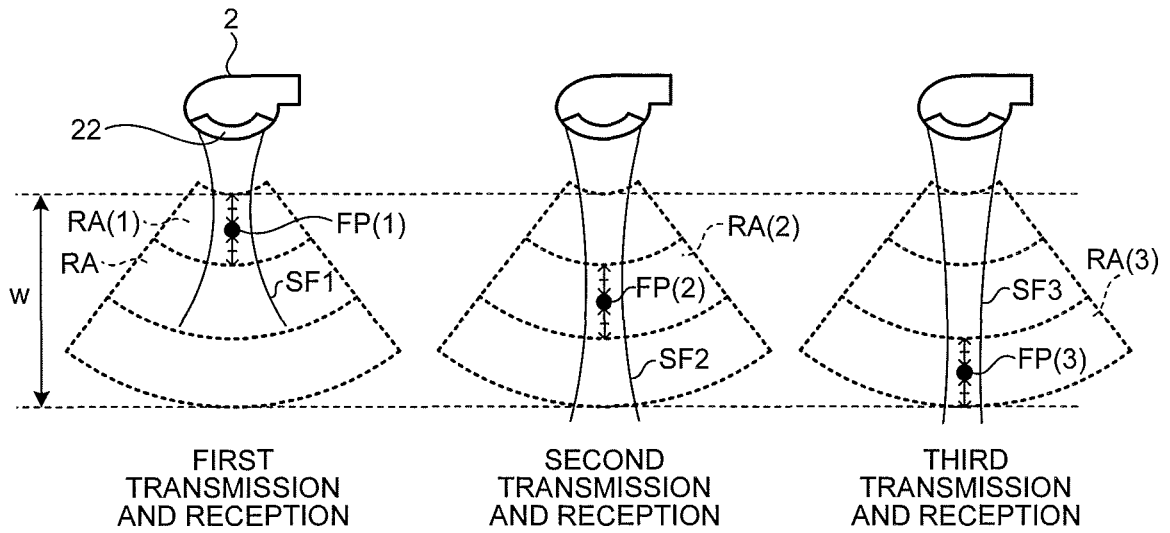

FIG.9

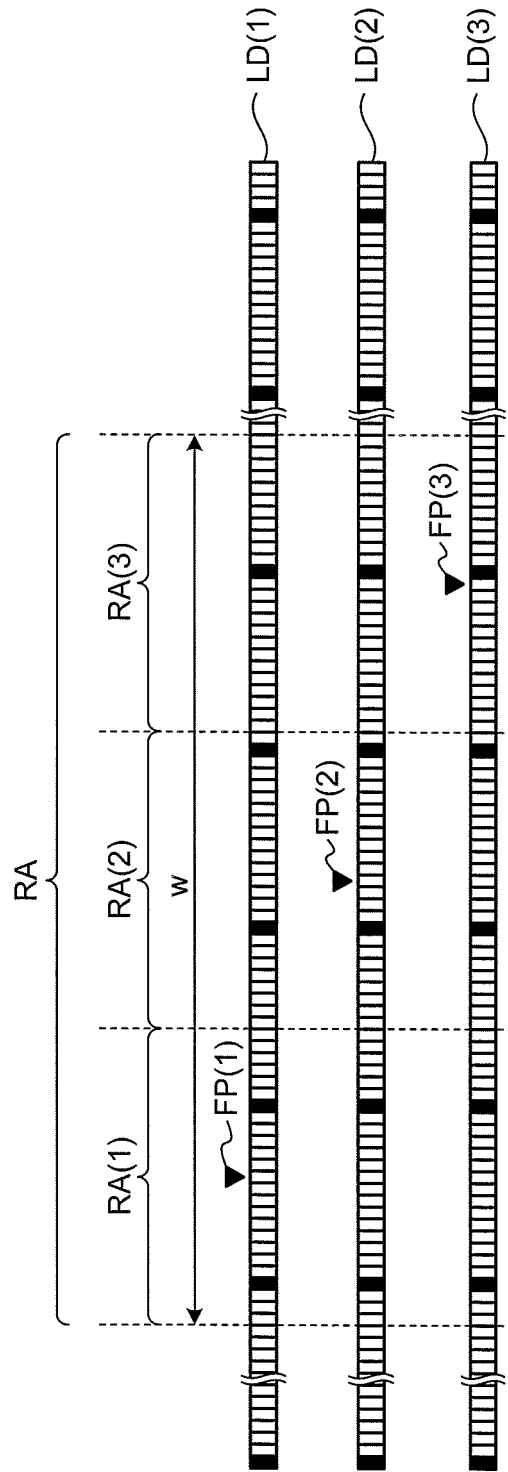

FIG.10

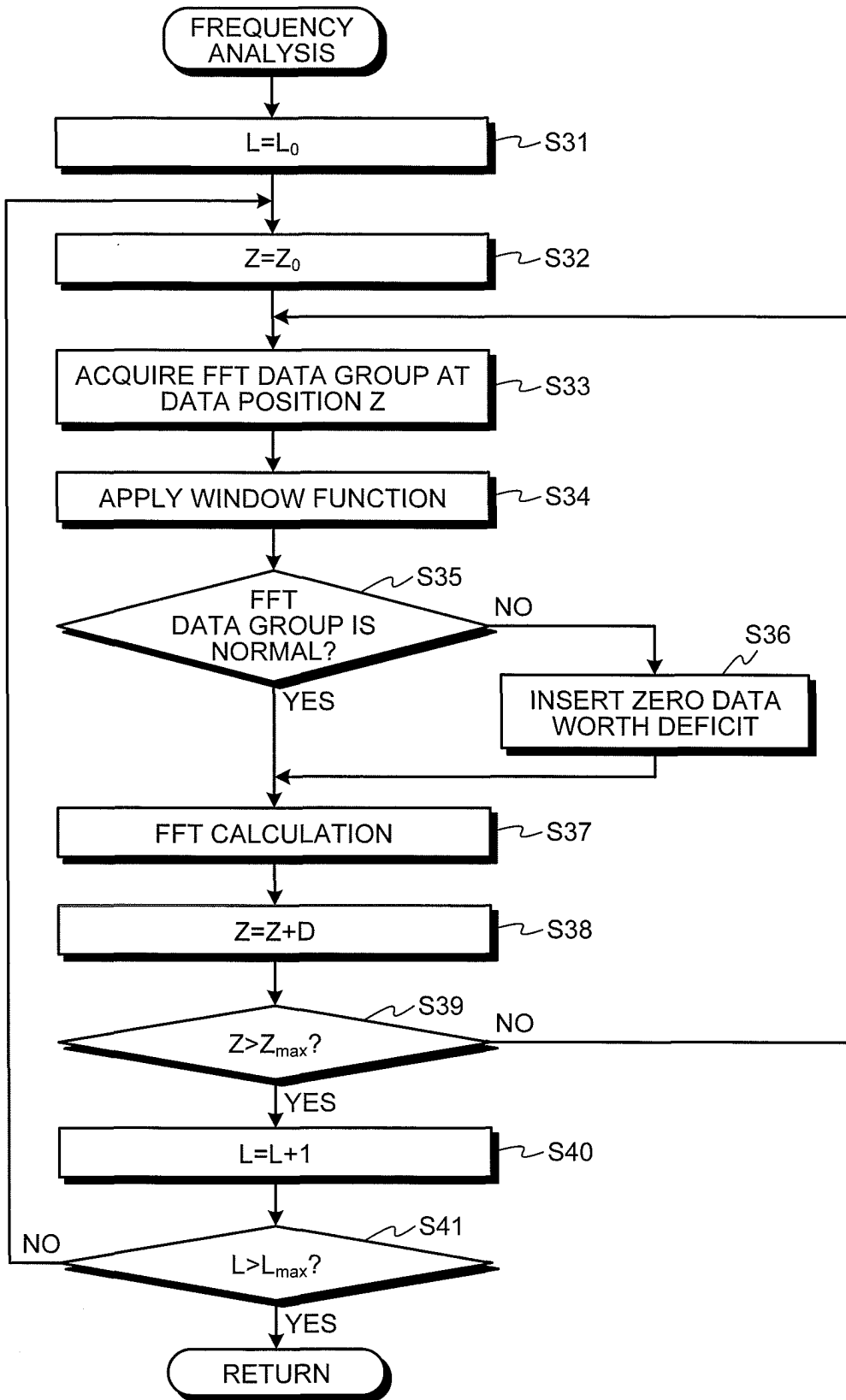

FIG.11

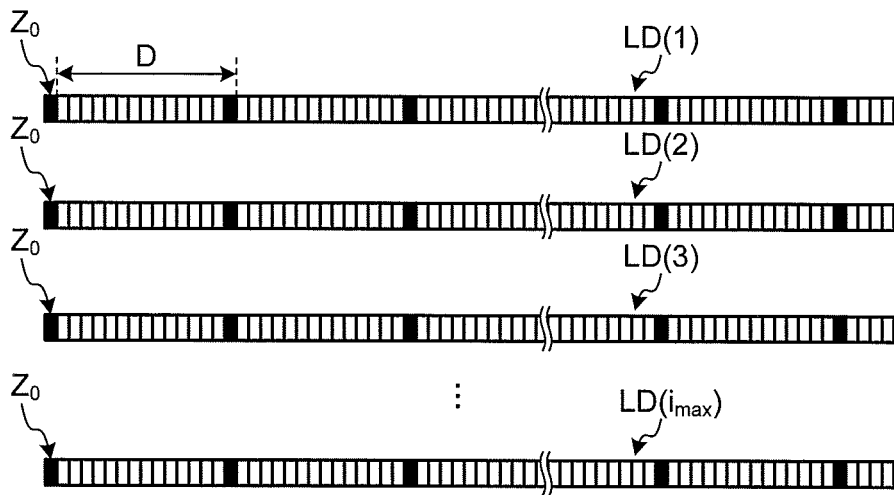

FIG.12

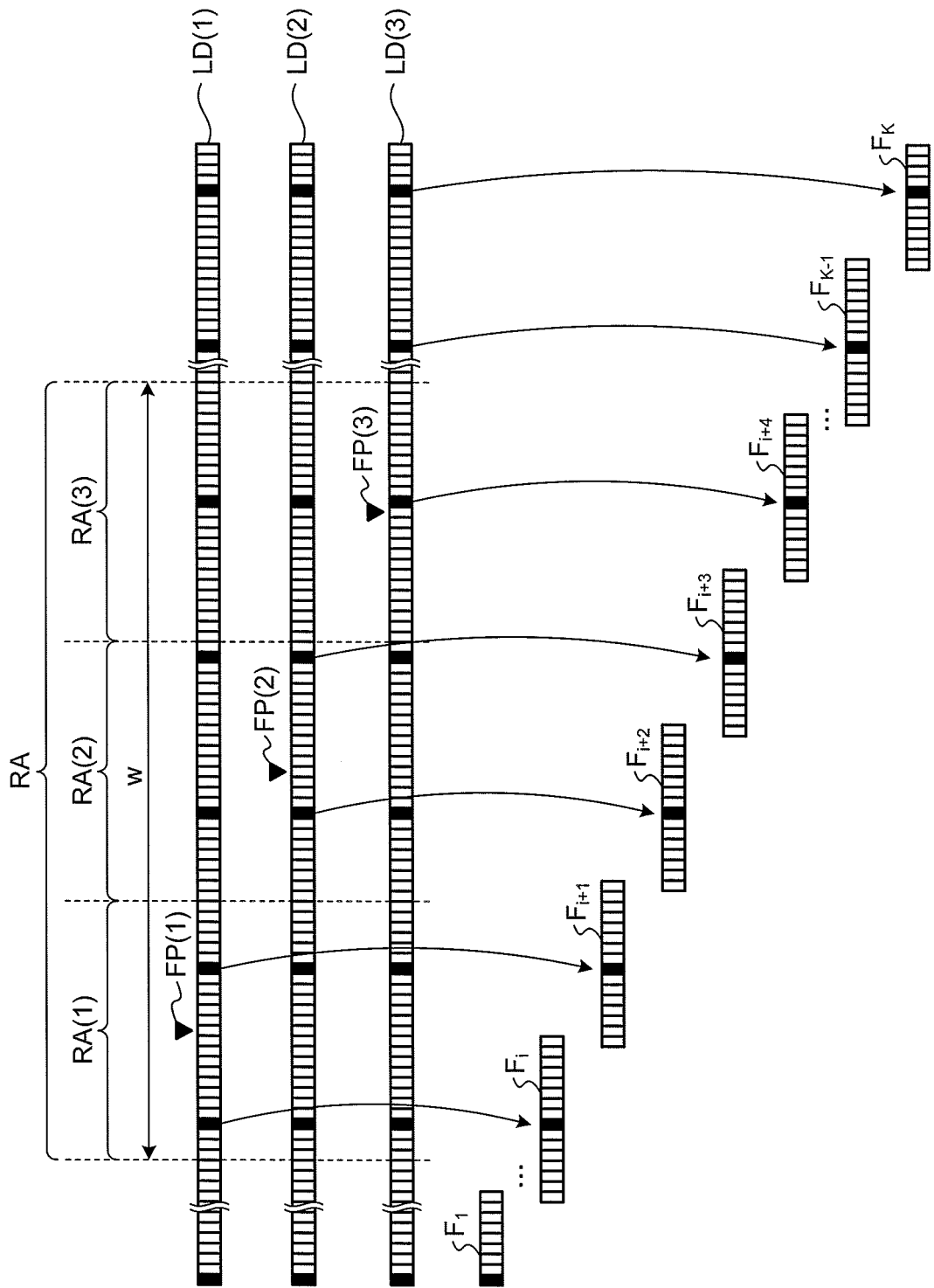

FIG.13

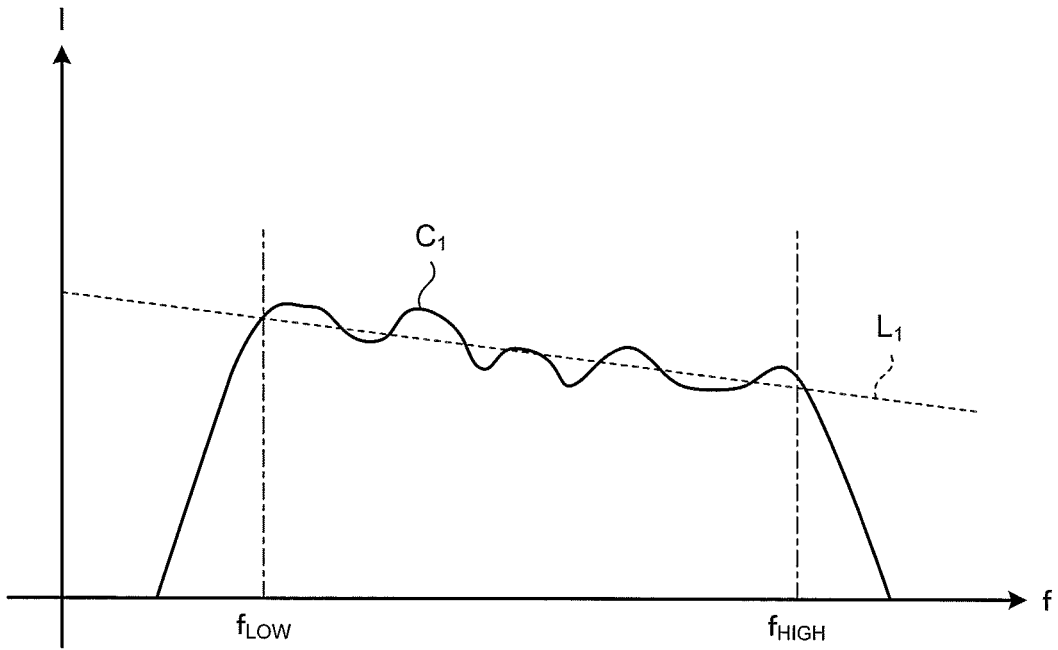

FIG.14

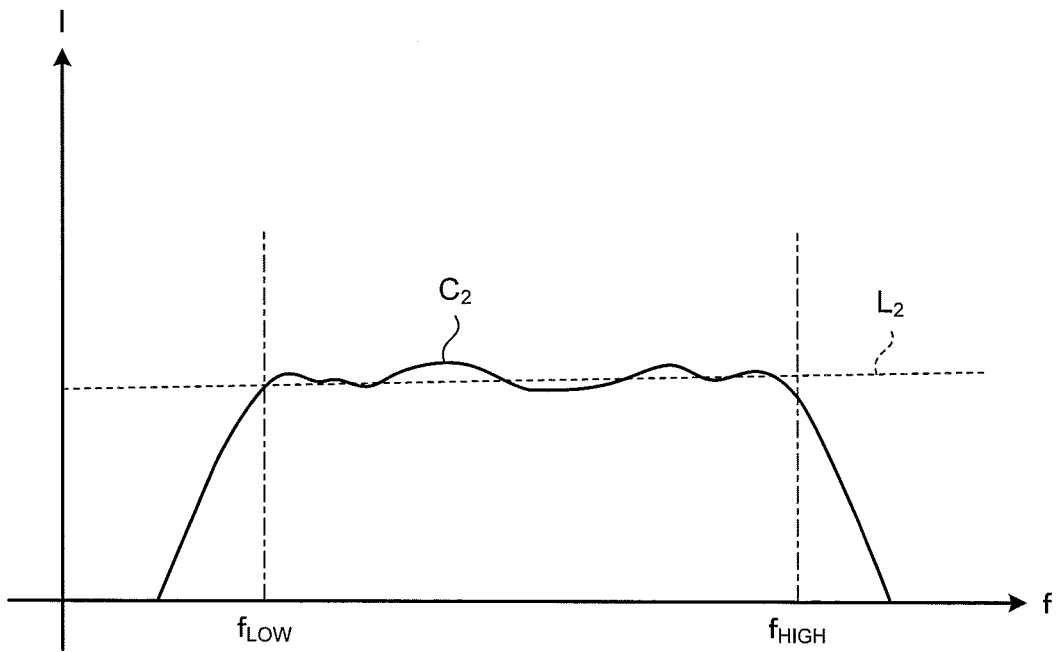

FIG.15

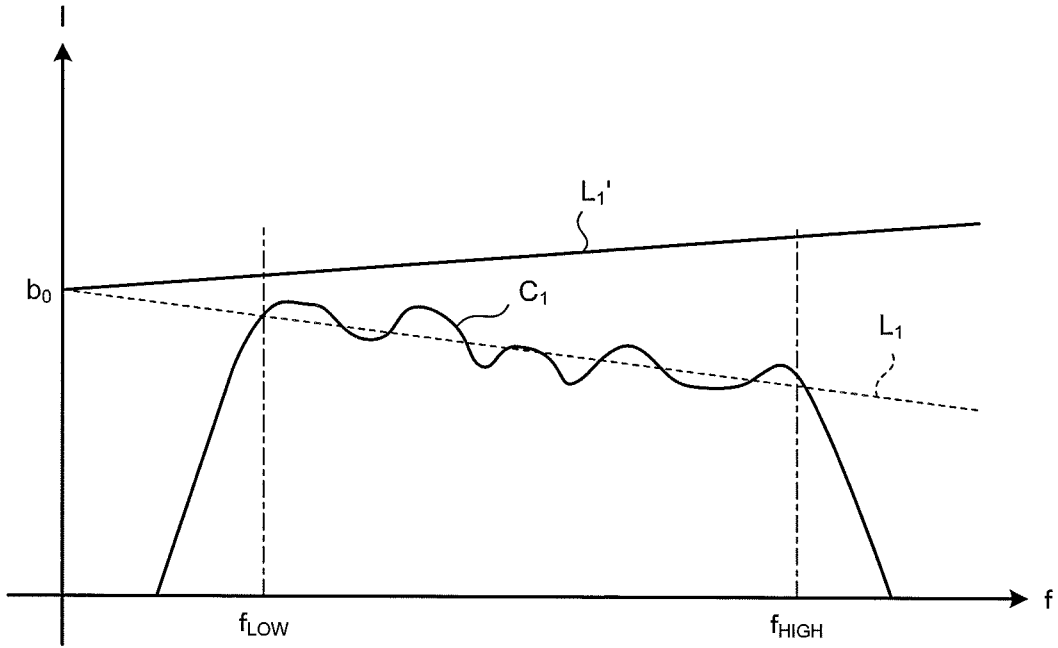

FIG.16

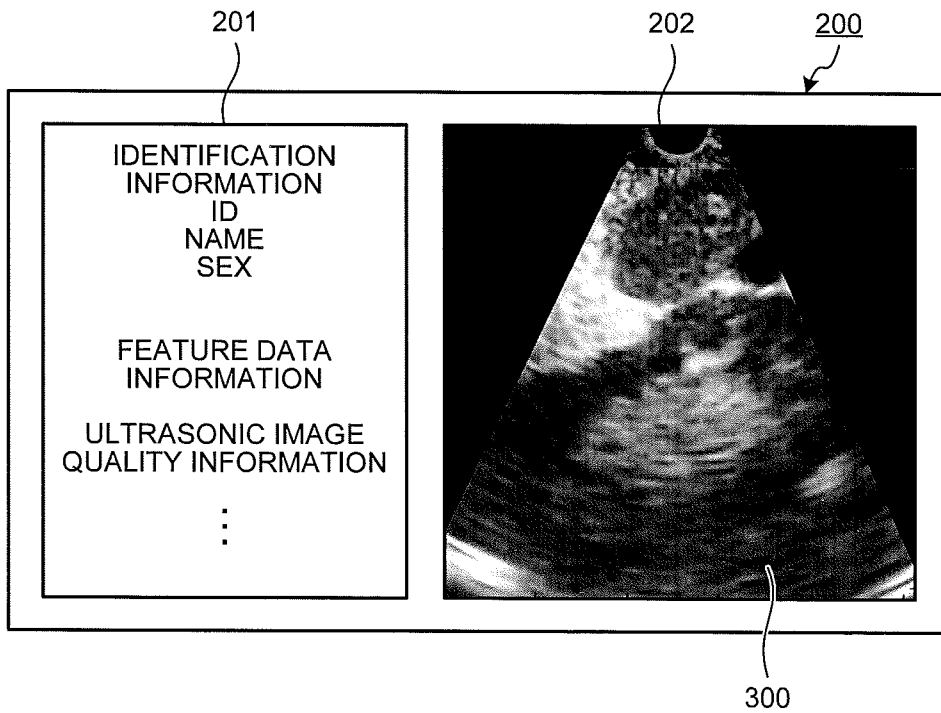

FIG.17

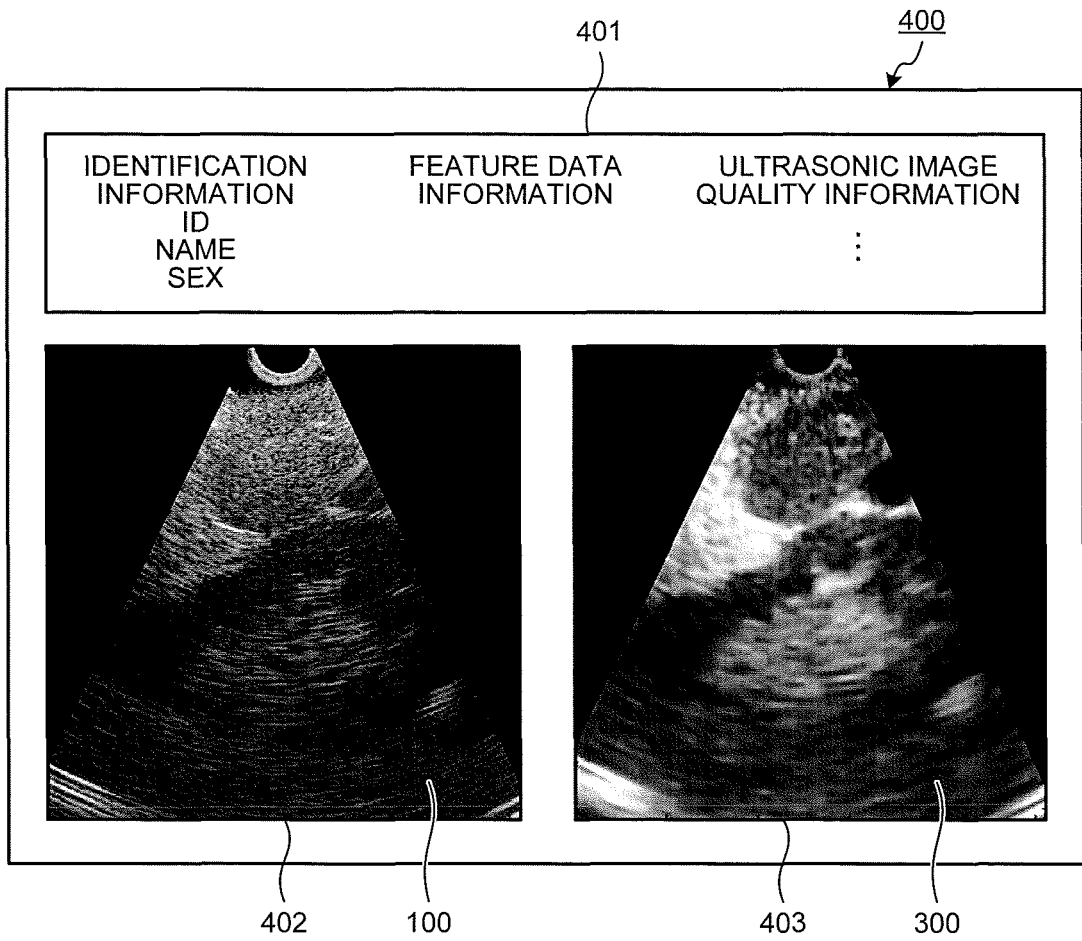

FIG.18

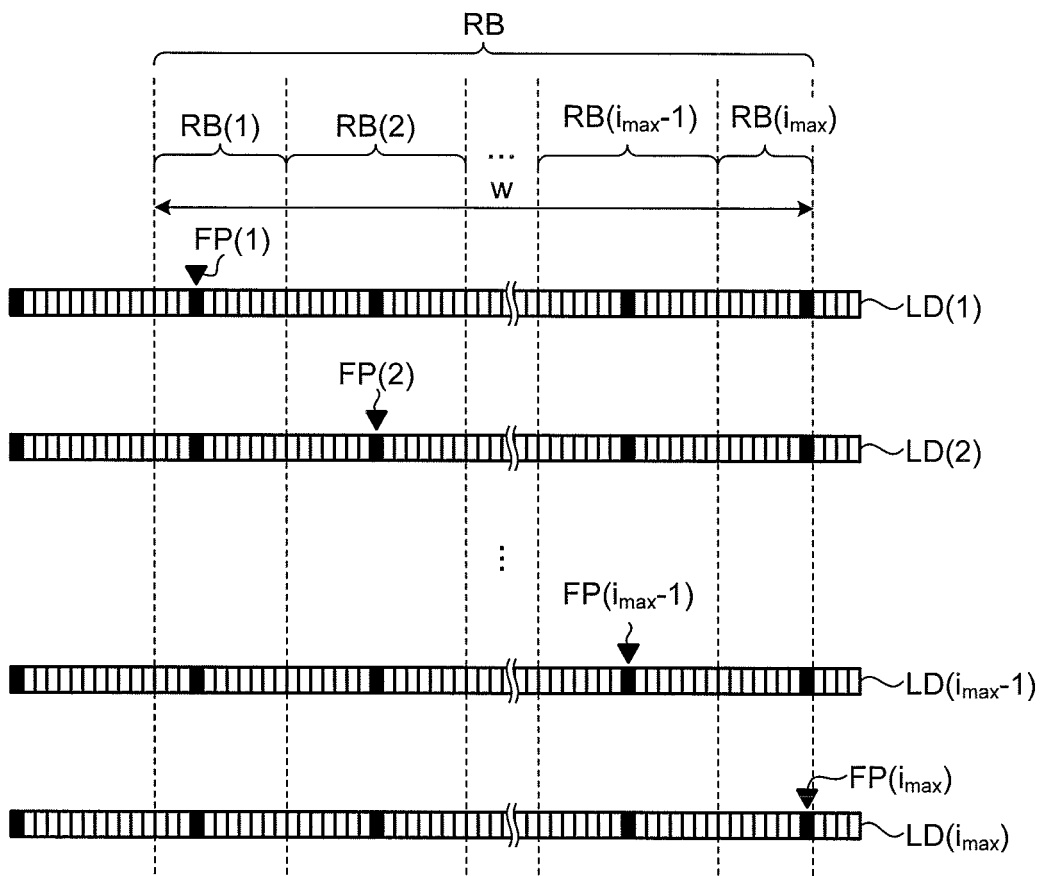
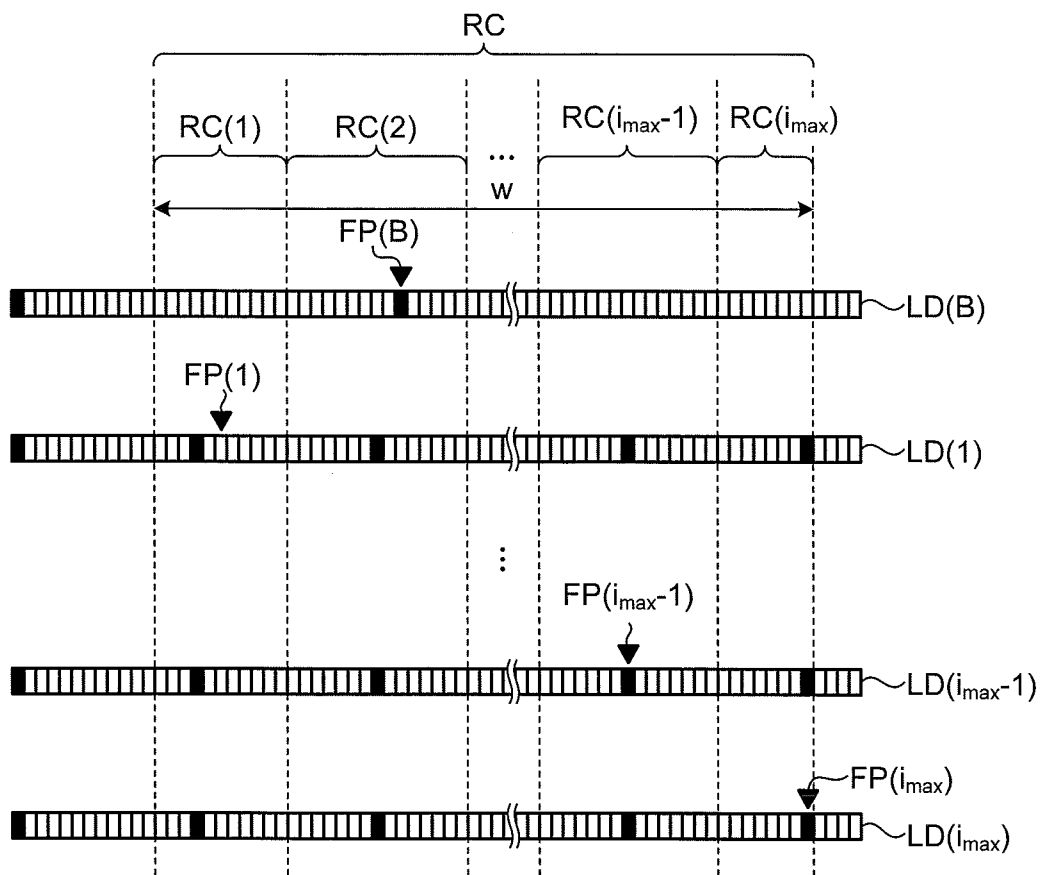

FIG.19



REFERENCES CITED IN THE DESCRIPTION

This list of references cited by the applicant is for the reader's convenience only. It does not form part of the European patent document. Even though great care has been taken in compiling the references, errors or omissions cannot be excluded and the EPO disclaims all liability in this regard.

Patent documents cited in the description

- WO 2005122906 A [0003]
- WO 2012063928 A1 [0004]

专利名称(译)	超声波观察装置，超声波观察装置的操作方法，超声波观察装置的操作程序		
公开(公告)号	EP2904975B1	公开(公告)日	2018-03-21
申请号	EP2013843757	申请日	2013-09-24
[标]申请(专利权)人(译)	奥林巴斯医疗株式会社		
申请(专利权)人(译)	奥林巴斯医疗系统股份有限公司.		
当前申请(专利权)人(译)	OLYMPUS CORPORATION		
[标]发明人	EDA HIROTAKA		
发明人	EDA, HIROTAKA		
IPC分类号	A61B8/00 A61B8/08		
CPC分类号	A61B8/0858 A61B8/4461 A61B8/463 A61B8/469 A61B8/485 A61B8/5207 A61B8/5246 A61B8/5269 A61B8/54 G01S7/5202 G01S7/52033 G01S7/52036 G01S7/52073 G01S7/52074 A61B8/14		
优先权	2012219764 2012-10-01 JP		
其他公开文献	EP2904975A4 EP2904975A1		
外部链接	Espacenet		

摘要(译)

超声波观察装置包括：感兴趣区域设定单元，其能够设定关于样本中感兴趣区域的位置和大小的信息；焦点计算单元，基于由关注区域设置单元设置的关注区域的大小信息，计算关注区域中的多个焦点；发送和接收单元，其执行聚焦在由焦点计算单元计算的焦点上的超声波的发送和接收；频率分析单元，通过参考焦点分析由发送和接收单元接收的超声波来计算多个频谱；特征数据提取单元，通过近似频谱提取由频率分析单元计算的频谱的特征数据；以及图像处理单元，其生成具有与由特征数据提取单元提取的特征数据相对应的显示模式的超声图像数据。

