



(11) **EP 2 249 178 A1**

(12) **EUROPEAN PATENT APPLICATION**

(43) Date of publication:
10.11.2010 Bulletin 2010/45

(51) Int Cl.:
G01S 15/89 (2006.01) G06T 7/00 (2006.01)
G06T 3/60 (2006.01)

(21) Application number: **10156169.4**

(22) Date of filing: **11.03.2010**

(84) Designated Contracting States:
AT BE BG CH CY CZ DE DK EE ES FI FR GB GR HR HU IE IS IT LI LT LU LV MC MK MT NL NO PL PT RO SE SI SK SM TR
Designated Extension States:
AL BA ME RS

(72) Inventors:
• **Kim, Chul An**
Seoul 135-851 (KR)
• **Kim, Sung Yoon**
Seoul 135-851 (KR)
• **Lee, Sung Mo**
Seoul 137-030 (KR)

(30) Priority: **27.04.2009 KR 20090036300**

(74) Representative: **Schmid, Wolfgang**
Lorenz & Kollegen
Patentanwälte Partnerschaftsgesellschaft
Alte Ulmer Strasse 2
89522 Heidenheim (DE)

(71) Applicant: **Medison Co., Ltd.**
Kangwon-do 250-870 (KR)

(54) **Arranging a three-dimensional ultrasound image in an ultrasound system**

(57) Embodiments for arranging a 3D (three-dimensional) ultrasound image (210) are disclosed.

In one embodiment, by way of non-limiting example, an ultrasound system (100) comprises: a storage unit (120) for storing a plurality of reference position information each corresponding to a plurality of target objects; a user input unit (110) configured to receive input information for selecting a target object (220); an ultrasound data acquisition unit (130) configured to transmit and receive ultrasound signals to and from the target object (220) to thereby output ultrasound data; and a processing unit (140) in communication with the storage unit (120), the user input unit (110) and the ultrasound data acquisition unit (130), the processing unit (140) being configured to form a 3D ultrasound image (210) based on the ultrasound data and to perform position arrangement of the 3D ultrasound image (210) based on reference position information corresponding to the input information.

FIG. 1

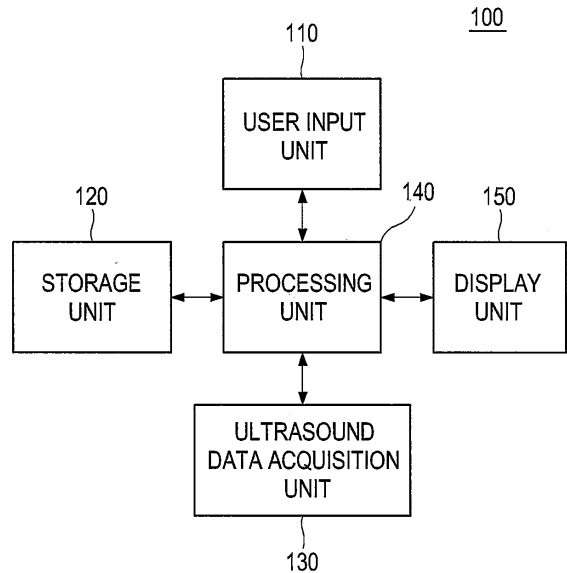

EP 2 249 178 A1

FIG. 5

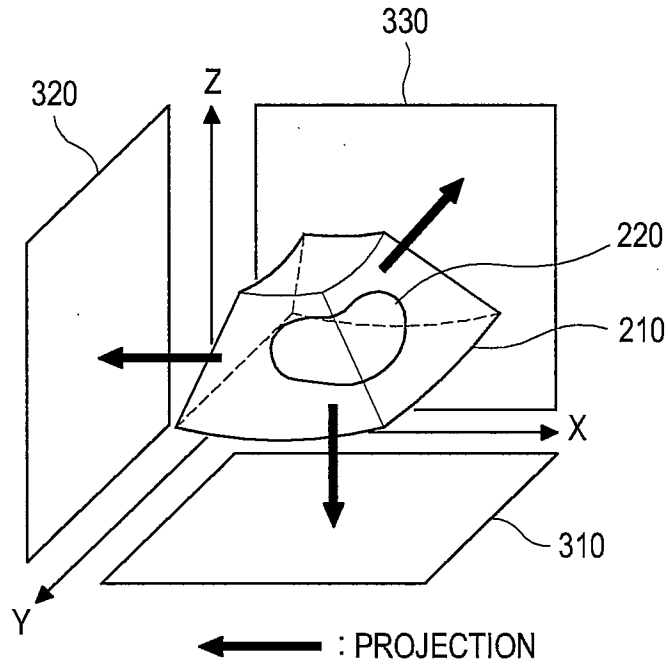

Description

CROSS-REFERENCE TO RELATED APPLICATIONS

[0001] The present application claims priority from Korean Patent Application No. 10-2009-0036300 filed on April 27, 2009, the entire subject matter of which is incorporated herein by reference.

TECHNICAL FIELD

[0002] The present disclosure generally relates to ultrasound systems, and more particularly to arranging a 3D (three-dimensional) ultrasound image in an ultrasound system.

BACKGROUND

[0003] An ultrasound system has become an important and popular diagnostic tool since it has a wide range of applications. Specifically, due to its non-invasive and non-destructive nature, the ultrasound system has been extensively used in the medical profession. Modern high-performance ultrasound systems and techniques are commonly used to produce 2D (two-dimensional) or 3D (three-dimensional) ultrasound images of internal features of a target object (e.g., human organs).

[0004] The ultrasound system may provide the three-dimensional ultrasound image including clinical information such as spatial information and anatomical figures of the target object, which cannot be provided by the two-dimensional ultrasound image. The ultrasound system may transmit ultrasound signals into the target object, receive ultrasound echo signals reflected from the target objects and form volume data based on the ultrasound echo signals. The ultrasound system may further form the three-dimensional ultrasound image including the clinical information by rendering the volume data.

[0005] Generally, a position of the target object in the 3D ultrasound image is changed according to a position of an ultrasound probe, which transmits and receives ultrasound signals to and from the target object. Thus, there is a problem in that a user has to move or rotate the 3D ultrasound image in order to arrange the 3D ultrasound image.

SUMMARY

[0006] Embodiments for providing a plurality of slice images in an ultrasound system are disclosed herein. In one embodiment, by way of non-limiting example, an ultrasound system comprises: a storage unit for storing a plurality of reference position information each corresponding to a plurality of target objects; a user input unit configured to receive input information for selecting a target object; an ultrasound data acquisition unit configured to transmit and receive ultrasound signals to and from the target object to thereby output ultrasound data; and

a processing unit in communication with the storage unit, the user input unit and the ultrasound data acquisition unit, the processing unit being configured to form a 3D ultrasound image based on the ultrasound data and perform position arrangement of the 3D ultrasound image based on reference position information corresponding to the input information.

[0007] In another embodiment, there is provided a method of arranging a 3D ultrasound image, comprising: a) receiving input information for selecting a target object; b) transmitting and receiving ultrasound signals to and from the target object to thereby output ultrasound data; c) forming a 3D ultrasound image based on the ultrasound data; and d) performing a position arrangement of the 3D ultrasound image based on reference position information corresponding to the input information, wherein the reference position information is stored in a storage unit corresponding to a plurality of target objects.

[0008] In yet another embodiment, there is provided a computer readable medium comprising computer executable instructions configured to perform the following acts: a) receiving input information for selecting a target object; b) transmitting and receiving ultrasound signals to and from the target object to thereby output ultrasound data; c) forming a 3D ultrasound image based on the ultrasound data; and d) performing a position arrangement of the 3D ultrasound image based on reference position information corresponding to the input information, wherein the reference position information is stored in a storage unit corresponding to a plurality of target objects.

[0009] The Summary is provided to introduce a selection of concepts in a simplified form that are further described below in the Detailed Description. This Summary is not intended to identify key or essential features of the claimed subject matter, nor is it intended to be used in determining the scope of the claimed subject matter.

BRIEF DESCRIPTION OF THE DRAWINGS

[0010]

- Figure 1 is a block diagram showing an illustrative embodiment of an ultrasound system.
- Figure 2 is a block diagram showing an illustrative embodiment of an ultrasound data acquisition unit.
- Figure 3 is a schematic diagram showing an example of acquiring ultrasound data corresponding to a plurality of frames.
- Figure 4 is a block diagram showing an illustrative embodiment of a processing unit.
- Figure 5 is a schematic diagram showing an example of projecting a 3D ultrasound image to an XY plane, a YZ plane and an XZ plane.
- Figure 6 is a schematic diagram showing an example of a 2D projection image of the XY plane.
- Figure 7 is a schematic diagram showing an example

of a 2D projection image of the YZ plane.
 Figure 8 is a schematic diagram showing an example
 of a 2D projection image of the XZ plane.

DETAILED DESCRIPTION

[0011] A detailed description may be provided with reference to the accompanying drawings. One of ordinary skill in the art may realize that the following description is illustrative only and is not in any way limiting. Other embodiments of the present invention may readily suggest themselves to such skilled persons having the benefit of this disclosure.

[0012] An ultrasound system 100 in accordance with an illustrative embodiment is shown in Fig. 1. As depicted therein, the ultrasound system 100 may include a user input unit 110. The user input unit 110 may receive input information from a user. The input information may be information for selecting a target object to form a 3D (three-dimensional) ultrasound image from a subject (e.g., a patient). The target object may include a heart, a liver, a blood vessel, a lesion or the like. However, the target object may not be limited thereto. The user input unit 110 may include a control panel, a mouse, a keyboard or the like, although it may not be limited thereto.

[0013] The ultrasound system 100 may further include a storage unit 120. The storage unit 120 may store a plurality of reference position information each corresponding to a plurality of target objects. The reference position information may be information for arranging the 3D ultrasound image to a predetermined position. In one embodiment, the reference position information may include a plurality of predetermined pixel distances between pixels corresponding to contour points of the target object. The storage unit 120 may store a mapping table providing the plurality of reference position information each corresponding to a plurality of target objects.

[0014] The ultrasound system 100 may further include an ultrasound data acquisition unit 130. The ultrasound data acquisition unit 130 may transmit and receive ultrasound signals to and from a target object to thereby output ultrasound data. The ultrasound data acquisition unit 130 may include a transmit (Tx) signal generating section 131, as shown in Figure 2.

[0015] Referring to Figure 2, the Tx signal generating section 131 may be configured to generate Tx signals. The Tx signal generating section 131 may perform the generation of the Tx signals at every predetermined time to thereby form a plurality of Tx signals for obtaining each of frames F_i ($1 \leq i \leq N$) representing the target object, as shown in Figure 3. The frames F_i ($1 \leq i \leq N$) may represent a plurality of sectional planes of the target object.

[0016] The ultrasound data acquisition unit 130 may further include an ultrasound probe 132 containing a plurality of elements for reciprocally converting between ultrasound signals and electrical signals. The ultrasound probe 132 may be configured to transmit ultrasound signals into the target object in response to the Tx signals.

The ultrasound probe 132 may further receive echo signals reflected from the target object to thereby output received signals. The received signals may be analog signals. The ultrasound probe 112 may include a three-dimensional mechanical probe, a two-dimensional array probe or the like.

[0017] The ultrasound data acquisition unit 130 may further include a beam former 133. The beam former 133 may convert the received signals into digital signals. The beam former 133 may further apply delays to the digital signals in consideration of distances between the plurality of elements of the ultrasound probe 132 and focal points to thereby output digital receive-focused signals.

[0018] The ultrasound data acquisition unit 130 may further include an ultrasound data forming section 134. The ultrasound data forming section 134 may form ultrasound data corresponding to each of the frames F_i ($1 \leq i \leq N$) based on the digital receive-focused signals.

[0019] Referring back to Figure 1, the ultrasound system 100 may further include a processing unit 140, which may be coupled to the user input unit 110, the storage unit 120 and the ultrasound data acquisition unit 130. Figure 4 is a block diagram showing an illustrative embodiment of the processing unit 140. Referring to Figure 4, the processing unit 140 may include a volume data forming section 141, an image forming section 142, a plane setting section 143, a projecting section 144, a contour point detecting section 145, a position information forming section 146, a skewness calculating section 147 and an arranging section 148.

[0020] The volume data forming section 141 may synthesize the ultrasound data corresponding to the frames F_i ($1 \leq i \leq N$) to thereby form volume data including the frames F_i ($1 \leq i \leq N$). The volume data may include a plurality of voxels having brightness values.

[0021] The image forming section 142 may render the volume data provided from the volume data forming section 141 to thereby form the 3D ultrasound image. The methods of rendering the volume data are well known in the art. Thus, they have not been described in detail so as not to unnecessarily obscure the present invention.

[0022] The plane setting section 143 may set a plurality of planes for projecting the 3D ultrasound image. In one embodiment, the plane setting section 143 may set an XY plane 310, a YZ plane 320 and an XZ plane 330 for projecting the 3D ultrasound image 210, as shown in Figure 5. In Figure 5, reference numeral 220 represents the target object.

[0023] The projecting section 144 may project the 3D ultrasound image to the XY plane 310, the YZ plane 320 and the XZ plane 330 to thereby form 2D (two-dimensional) projection images on the XY plane 310, the YZ plane 320 and the XZ plane 330. The methods of projecting the 3D ultrasound image are well known in the art. Thus, they have not been described in detail so as not to unnecessarily obscure the present invention.

[0024] The contour point detecting section 145 may detect contour points of the target object in the 2D pro-

jection images of the XY plane 310, the YZ plane 320 and the XZ plane 330. The contour point may be detected by using an edge mask such as Sobel, Prewitt, Robert, Canny mask or the like. The contour point may be detected based on the differences between eigenvalues using structure tensors.

[0025] The position information forming section 146 may calculate pixel distances between pixels corresponding to the detected contour points to thereby form position information including the pixel distances.

[0026] In one embodiment, the position information forming section 146 may calculate pixel distances between the pixels $P_{X1,Y4}$, $P_{X2,Y3}$, $P_{X2,Y5}$, $P_{X3,Y2}$, $P_{X3,Y6}$, $P_{X4,Y2}$, $P_{X4,Y6}$, $P_{X5,Y2}$, $P_{X5,Y6}$, $P_{X6,Y3}$, $P_{X6,Y5}$ and $P_{X7,Y4}$ corresponding to the detected contour points in the 2D projection image of the XY plane 310, as shown in Figure 6. More particularly, the position information forming section 146 may calculate pixel distance ($D_{X2}=2$) between pixels $P_{X2,Y3}$ and $P_{X2,Y5}$ located in X2, pixel distance ($D_{X3}=4$) between pixels $P_{X3,Y2}$ and $P_{X3,Y6}$ located in X3, pixel distance ($D_{X4}=4$) between pixels $P_{X4,Y2}$ and $P_{X4,Y6}$ located in X4, pixel distance ($D_{X5}=4$) between pixels $P_{X5,Y2}$ and $P_{X5,Y6}$ located in X5, and pixel distance ($D_{X6}=2$) between pixels $P_{X6,Y3}$ and $P_{X6,Y5}$ located in X6. Also, the position information forming section 146 may further calculate pixel distance ($D_{Y21}=1$) between pixels $P_{X3,Y2}$ and $P_{X4,Y2}$ located in Y2, pixel distance ($D_{Y22}=1$) between pixels $P_{X4,Y2}$ and $P_{X5,Y2}$ located in Y2, pixel distance ($D_{Y23}=2$) between pixels $P_{X3,Y2}$ and $P_{X5,Y2}$ located in Y2, pixel distance ($D_{Y3}=4$) between pixels $P_{X2,Y3}$ and $P_{X6,Y3}$ located in Y3, pixel distance ($D_{Y4}=6$) between pixels $P_{X1,Y4}$ and $P_{X7,Y4}$ located in Y4, pixel distance ($D_{Y5}=4$) between pixels $P_{X2,Y5}$ and $P_{X6,Y5}$ located in Y5, pixel distance ($D_{Y61}=1$) between pixels $P_{X3,Y6}$ and $P_{X4,Y6}$ located in Y6, pixel distance ($D_{Y62}=1$) between pixels $P_{X4,Y6}$ and $P_{X5,Y6}$ located in Y6, and pixel distance ($D_{Y63}=2$) between pixels $P_{X3,Y6}$ and $P_{X5,Y6}$ located in Y6.

[0027] Similarly, the position information forming section 146 may further calculate pixel distances between the pixels $P_{Y1,Z4}$, $P_{Y2,Z3}$, $P_{Y2,Z5}$, $P_{Y3,Z2}$, $P_{Y3,Z6}$, $P_{Y4,Z1}$, $P_{Y4,Z7}$, $P_{Y5,Z2}$, $P_{Y5,Z6}$, $P_{Y6,Z3}$, $P_{Y6,Z5}$ and $P_{Y7,Z4}$ corresponding to the detected contour points in the 2D projection image of the YZ plane 320, as shown in Figure 7. Also, the position information forming section 146 may further calculate pixel distances between the pixels $P_{X1,Z4}$, $P_{X2,Z4}$, $P_{X3,Z3}$, $P_{X3,Z5}$, $P_{X4,Z1}$, $P_{X4,Z2}$, $P_{X4,Z6}$, $P_{X5,Z2}$, $P_{X5,Z3}$, $P_{X5,Z5}$, $P_{X6,Z3}$, $P_{X6,Z4}$ and $P_{X7,Z4}$ corresponding to the detected contour points in the 2D projection image of the XZ plane 330, as shown in Figure 8. The position information forming section 146 may form the position information including the calculated pixel distances.

[0028] The skewness calculating section 147 may retrieve reference position information corresponding to the input information from the storage unit 120. The skewness calculating section 147 may further calculate skewness based on the position information and the retrieved reference position information to thereby form skewness

information. In one embodiment, the skewness calculating section 147 may calculate skewness between the pixel distances of the position information and the predetermined pixel distances of the retrieved reference position information to thereby form the skewness information. However, the methods of calculating the skewness may not be limited thereto.

[0029] The arranging section 148 may perform a position arrangement of the 3D ultrasound image based on the skewness information provided from the skewness calculating section 147. In one embodiment, the arrangement section 148 may compare the skewness of the skewness information with a predetermined threshold value. If the skewness is larger than the threshold value, then the arranging section 148 may calculate difference between the skewness and the threshold value. The arranging section 148 may further perform the position arrangement of the 3D ultrasound image by moving or rotating the 3D ultrasound image based on the calculated difference.

[0030] The projecting section 144, the contour point detecting section 145, the position information forming section 146, the skewness calculating section 147 and the arranging section 148 of the processing unit 140 may perform the position arrangement of the 3D ultrasound image until the skewness is smaller than the threshold value. That is, the 3D ultrasound image is arranged to the predetermined position.

[0031] Referring back to Figure 1, the ultrasound system 100 may further include a display unit 150. The display unit 150 may display the 3D ultrasound image.

[0032] Although embodiments have been described with reference to a number of illustrative embodiments thereof, it should be understood that numerous other modifications and embodiments can be devised by those skilled in the art that will fall within the spirit and scope of the principles of this disclosure. More particularly, numerous variations and modifications are possible in the component parts and/or arrangements of the subject combination arrangement within the scope of the disclosure, the drawings and the appended claims. In addition to variations and modifications in the component parts and/or arrangements, alternative uses will also be apparent to those skilled in the art.

Claims

1. An ultrasound system, comprising:

- a storage unit for storing a plurality of reference position information each corresponding to a plurality of target objects;
- a user input unit configured to receive input information for selecting a target object;
- an ultrasound data acquisition unit configured to transmit and receive ultrasound signals to and from the target object to thereby output ultra-

- sound data; and
 a processing unit in communication with the storage unit, the user input unit and the ultrasound data acquisition unit, the processing unit being configured to form a 3D ultrasound image based on the ultrasound data and perform position arrangement of the 3D ultrasound image based on reference position information corresponding to the input information.
2. The ultrasound system of Claim 1, wherein the processing unit comprises:
- a volume data forming section configured to form volume data based on the ultrasound data;
 - an image forming section configured to render the volume data to thereby form the 3D ultrasound image;
 - a plane setting section configured to set a plurality of planes for projecting the 3D ultrasound image;
 - a projecting section configured to project the 3D ultrasound image to the plurality of planes to thereby form 2D (two-dimensional) projection images;
 - a contour point detecting section configured to detect contour points of the target object in the 2D projection images;
 - a position information forming section configured to calculate pixel distances between pixels corresponding to the detected contour points to thereby form position information including the calculated pixel distances;
 - a skewness calculating section configured to retrieve the reference position information corresponding to the input information from the storage unit and calculate skewness based on the reference position information and the position information to thereby form skewness information; and
 - an arrangement section configured to perform the position arrangement of the 3D ultrasound image based on the skewness information.
3. The ultrasound system of Claim 2, wherein the planes comprise an XY plane, a YZ plane and an XZ plane.
4. The ultrasound system of Claim 3, wherein the position information forming section is configured to calculate a plurality of first pixel distances between pixels corresponding to the detected contour points in the 2D projection image of the XY plane, calculate a plurality of second pixel distances between pixels corresponding to the detected contour points in the 2D projection image of the YZ plane, calculate a plurality of third pixel distances between pixels corresponding to the detected contour points in the 2D
- projection image of the XZ plane and form the position information including the plurality of first, second and third pixel distances.
5. The ultrasound system of Claim 4, wherein the reference position information comprises a plurality of predetermined pixel distances between pixels corresponding to contour points of the target object.
6. The ultrasound system of Claim 5, wherein the skewness calculating section is configured to calculate the skewness between the plurality of first, second and third pixel distances of the position information and the plurality of predetermined pixel distances of the reference position information.
7. The ultrasound system of Claim 6, wherein the arranging section is configured to compare the skewness of the skewness information with a predetermined threshold value, calculate difference between the skewness and the threshold value when the skewness is larger than the threshold value, and move or rotate the 3D ultrasound image based on the calculated difference.
8. A method of arranging a 3D (three-dimensional) ultrasound image, comprising:
- a) receiving input information for selecting a target object;
 - b) transmitting and receiving ultrasound signals to and from the target object to thereby output ultrasound data;
 - c) forming a 3D ultrasound image based on the ultrasound data; and
 - d) performing a position arrangement of the 3D ultrasound image based on reference position information corresponding to the input information, wherein the reference position information is stored in a storage unit corresponding to a plurality of target objects.
9. The method of Claim 8, wherein the step d) comprises:
- d1) setting a plurality of planes for projecting the 3D ultrasound image;
 - d2) projecting the 3D ultrasound image to the plurality of planes to thereby form 2D (two-dimensional) projection images;
 - d3) detecting contour points of the target object in the 2D projection images;
 - d4) calculating pixel distances between pixels corresponding to the detected contour points to thereby form position information including the calculated pixel distances;
 - d5) retrieving the reference position information corresponding to the input information from the

- storage unit;
 d6) calculating a skewness based on the reference position information and the position information to thereby form skewness information; and
 d7) performing the position arrangement of the 3D ultrasound image based on the skewness information. 5
- 10.** The method of Claim 9, wherein the planes comprise an XY plane, a YZ plane and an XZ plane. 10
- 11.** The method of Claim 10, wherein the step d4) comprises:
 15
 calculating a plurality of first pixel distances between pixels corresponding to the contour points in the 2D projection image of the XY plane;
 calculating a plurality of second pixel distances between pixels corresponding to the contour points in the 2D projection image of the YZ plane; 20
 calculating a plurality of third pixel distances between pixels corresponding to the contour points in the 2D projection image of the XZ plane; and
 forming the position information including the plurality of first, second and third pixel distances. 25
- 12.** The method of Claim 11, wherein the reference position information comprises a plurality of predetermined pixel distances between pixels corresponding to contour points of the target object. 30
- 13.** The method of Claim 12, wherein the step d6) comprises:
 35
 calculating skewness between the plurality of first, second and third pixel distances of the position information and the plurality of predetermined pixel distances of the reference position information. 40
- 14.** The method of Claim 13, wherein the step d7) comprises:
 45
 comparing the skewness of the skewness information with a predetermined threshold value;
 calculating difference between the skewness and the threshold value when the skewness is larger than the threshold value; and
 moving or rotating the 3D ultrasound image based on the calculated difference. 50
- 15.** A computer readable medium comprising computer executable instructions configured to perform following acts:
 55
 a) receiving input information for selecting a tar-

get object;

b) transmitting and receiving ultrasound signals to and from the target object to thereby output ultrasound data;

c) forming a 3D ultrasound image based on the ultrasound data; and

d) performing a position arrangement of the 3D ultrasound image based on reference position information corresponding to the input information, wherein the reference position information is stored in a storage unit corresponding to a plurality of target objects.

FIG. 1

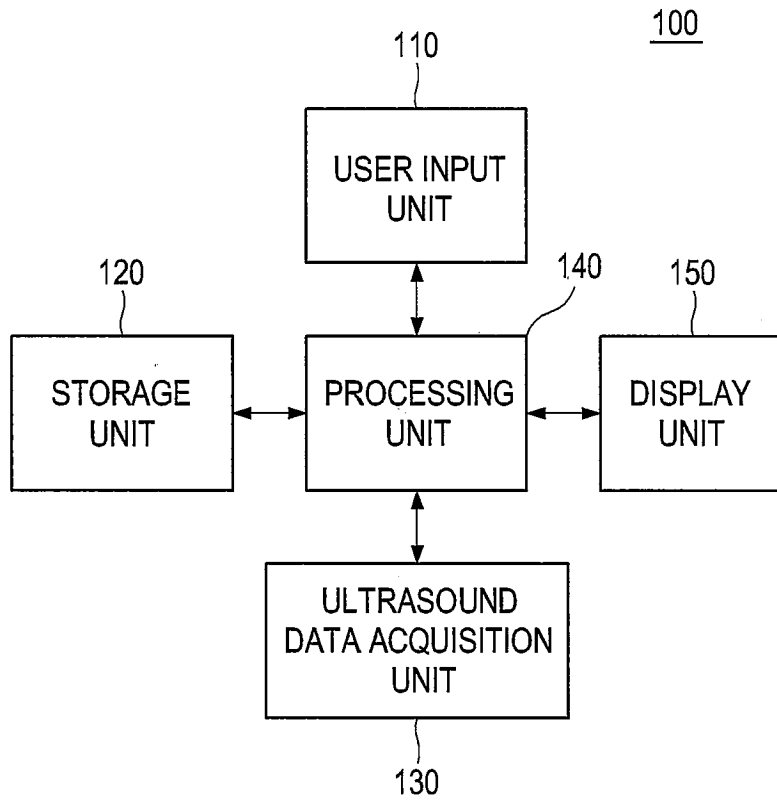

FIG. 2

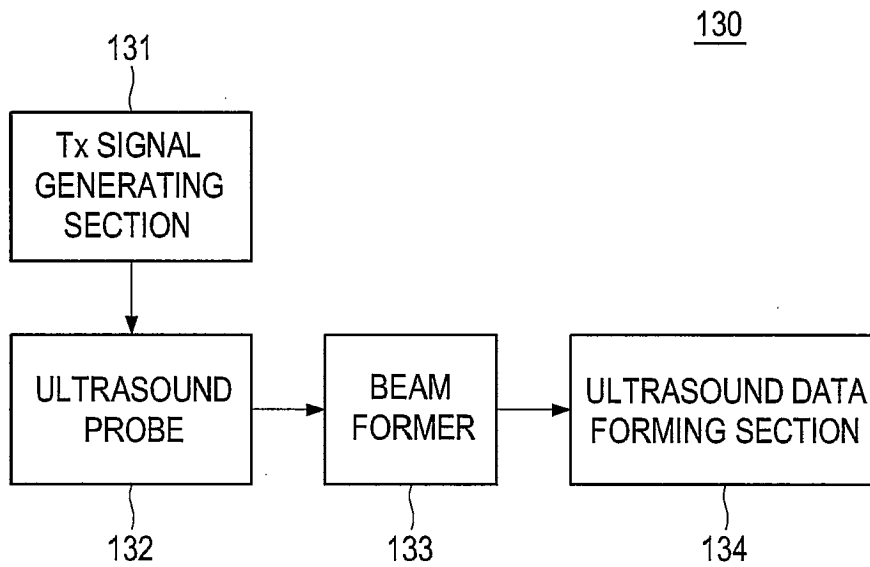

FIG. 3

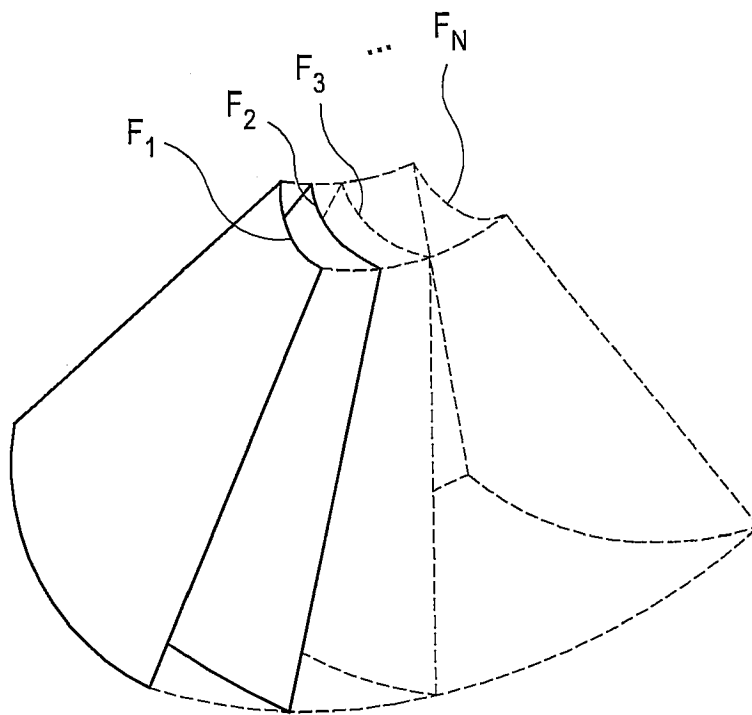

FIG. 4

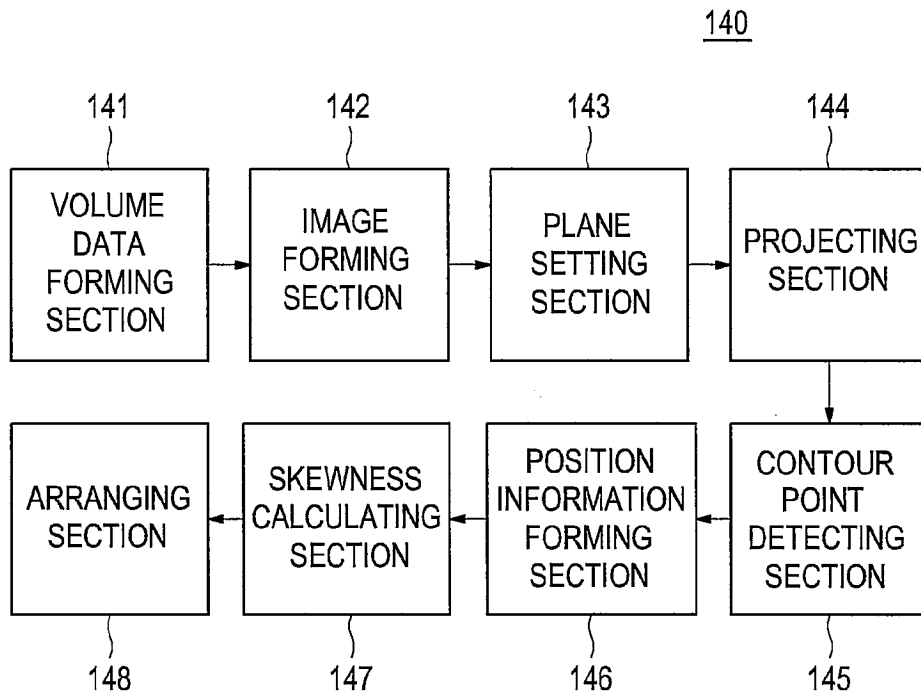

FIG. 5

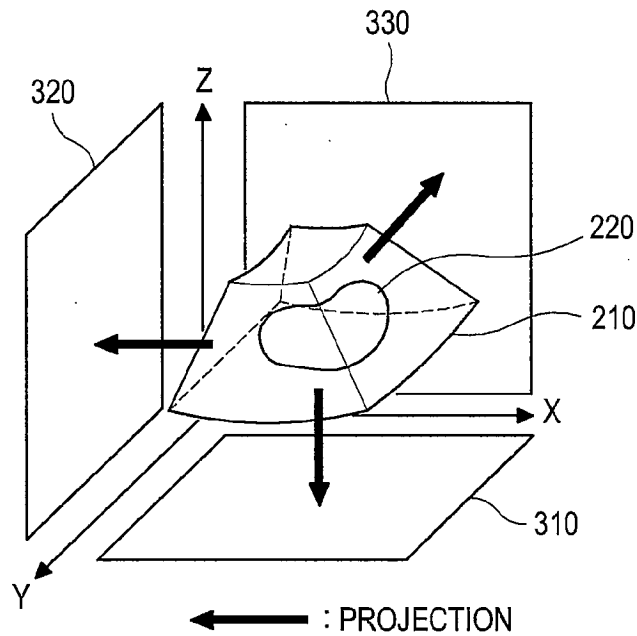

FIG. 6

310

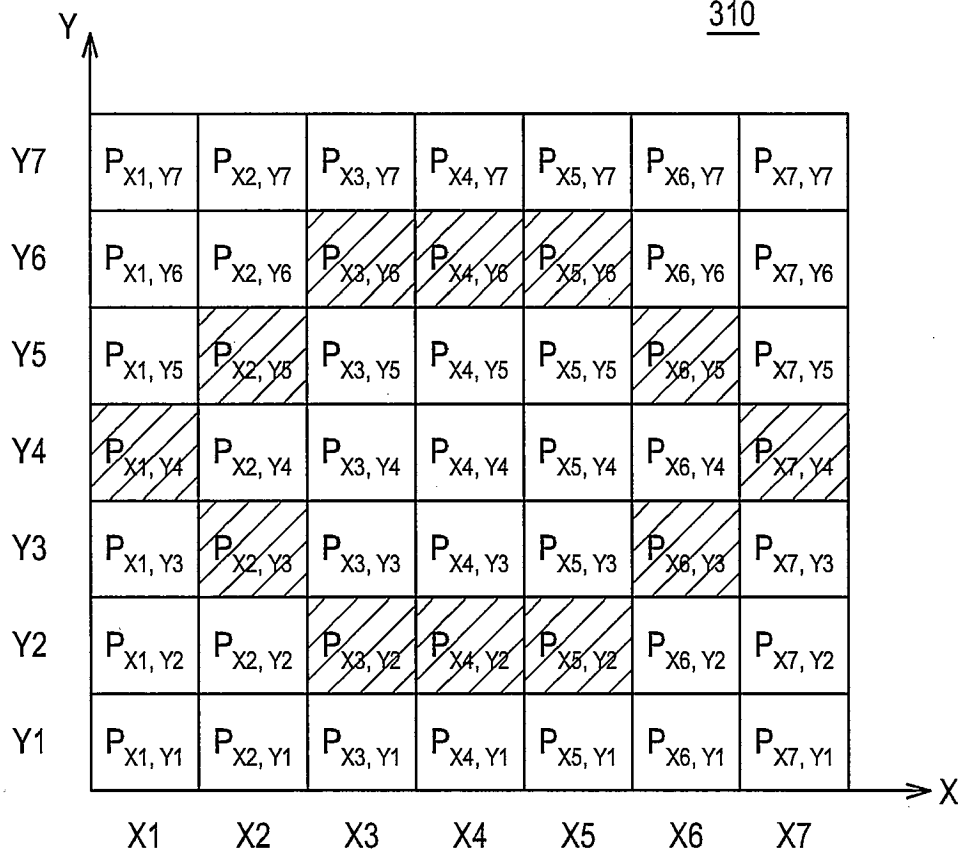

FIG. 7

320

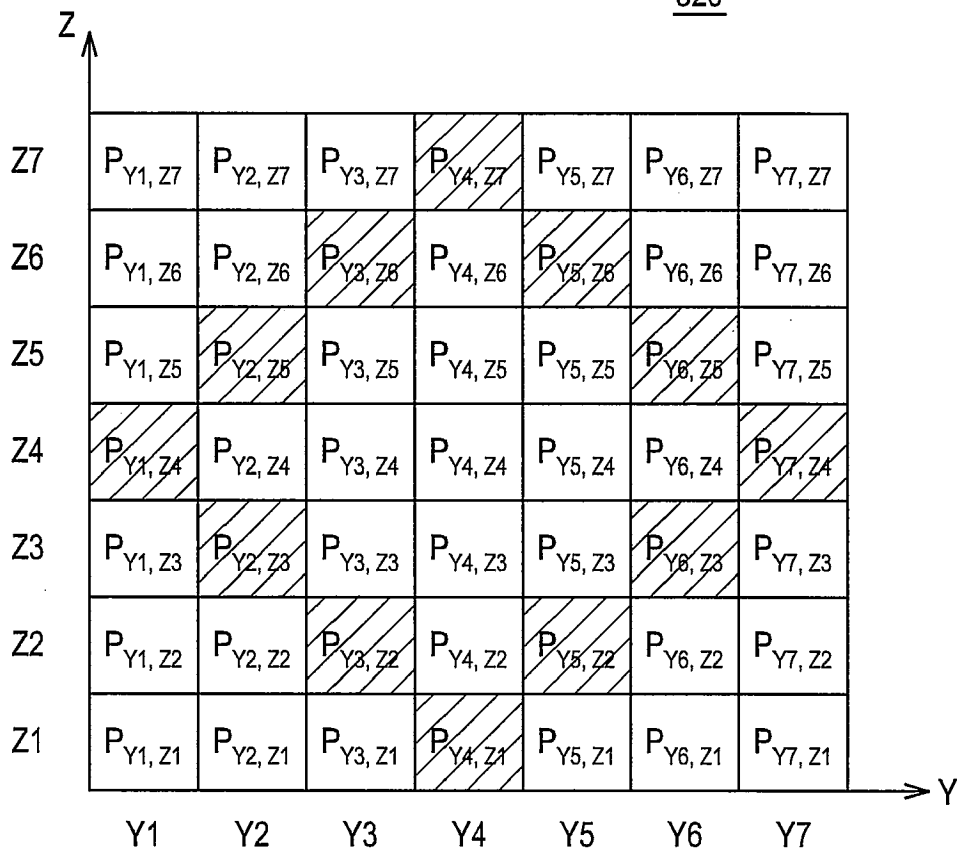
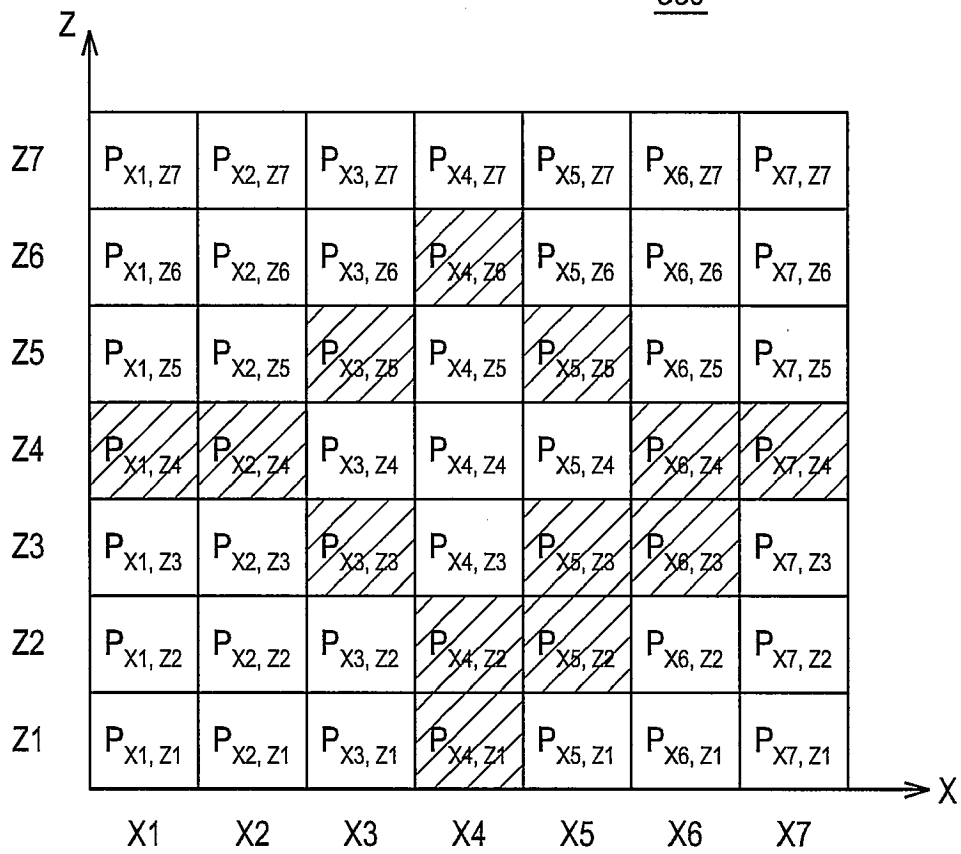

FIG. 8

330





EUROPEAN SEARCH REPORT

Application Number
EP 10 15 6169

DOCUMENTS CONSIDERED TO BE RELEVANT			
Category	Citation of document with indication, where appropriate, of relevant passages	Relevant to claim	CLASSIFICATION OF THE APPLICATION (IPC)
X	US 2008/186378 A1 (SHEN FEIMO [US] ET AL) 7 August 2008 (2008-08-07) * abstract; figures 1,2,5A,7 * * paragraph [0036] - paragraph [0038] * * paragraphs [0043], [0044], [0046] * -----	1,8,15	INV. G01S15/89 G06T7/00 G06T3/60
X	EP 1 717 758 A2 (BIOSENSE WEBSTER INC [US]) 2 November 2006 (2006-11-02) * abstract; figures 1,5-7 * * paragraphs [0058], [0069], [0076] * * paragraphs [0080], [0082], [0083] * * paragraphs [0087], [0089], [0101] * -----	1,8,15	
X	US 2006/034513 A1 (CAI ANMING H [US] ET AL) 16 February 2006 (2006-02-16) * abstract; figures 1,3 * * paragraphs [0021], [0025], [0027] * * paragraphs [0029], [0035] - [0037] * -----	1,8,15	
The present search report has been drawn up for all claims			TECHNICAL FIELDS SEARCHED (IPC)
			G01S G06T
Place of search		Date of completion of the search	Examiner
Munich		12 August 2010	Knoll, Bernhard
CATEGORY OF CITED DOCUMENTS			
X : particularly relevant if taken alone Y : particularly relevant if combined with another document of the same category A : technological background O : non-written disclosure P : intermediate document		T : theory or principle underlying the invention E : earlier patent document, but published on, or after the filing date D : document cited in the application L : document cited for other reasons & : member of the same patent family, corresponding document	

2
EPO FORM 1503 03.82 (F04C01)

**ANNEX TO THE EUROPEAN SEARCH REPORT
ON EUROPEAN PATENT APPLICATION NO.**

EP 10 15 6169

This annex lists the patent family members relating to the patent documents cited in the above-mentioned European search report. The members are as contained in the European Patent Office EDP file on
The European Patent Office is in no way liable for these particulars which are merely given for the purpose of information.

12-08-2010

Patent document cited in search report	Publication date	Patent family member(s)	Publication date
US 2008186378 A1	07-08-2008	NONE	

EP 1717758 A2	02-11-2006	AU 2006201647 A1	09-11-2006
		BR PI0601456 A	26-12-2006
		CA 2544012 A1	26-10-2006
		CN 1853576 A	01-11-2006
		JP 2006305358 A	09-11-2006
		KR 20060112241 A	31-10-2006
		US 2006241445 A1	26-10-2006

US 2006034513 A1	16-02-2006	WO 2006022815 A1	02-03-2006

REFERENCES CITED IN THE DESCRIPTION

This list of references cited by the applicant is for the reader's convenience only. It does not form part of the European patent document. Even though great care has been taken in compiling the references, errors or omissions cannot be excluded and the EPO disclaims all liability in this regard.

Patent documents cited in the description

- KR 1020090036300 [0001]

专利名称(译)	在超声系统中布置三维超声图像		
公开(公告)号	EP2249178A1	公开(公告)日	2010-11-10
申请号	EP2010156169	申请日	2010-03-11
申请(专利权)人(译)	MEDISON CO. , LTD.		
当前申请(专利权)人(译)	三星MEDISON CO. , LTD.		
[标]发明人	KIM CHUL AN KIM SUNG YOON LEE SUNG MO		
发明人	KIM, CHUL AN KIM, SUNG YOON LEE, SUNG MO		
IPC分类号	G01S15/89 G06T7/00 G06T3/60 A61B8/00		
CPC分类号	G01S15/8993 A61B8/483 G06T7/75 G06T15/08 G06T19/00 G06T2207/10136 G06T2207/30004 G06T2219/008		
代理机构(译)	SCHMID , WOLFGANG		
优先权	1020090036300 2009-04-27 KR		
其他公开文献	EP2249178B1		
外部链接	Espacenet		

摘要(译)

公开了用于布置3D (三维) 超声图像 (210) 的实施例。在一个实施例中，作为非限制性示例，超声系统 (100) 包括：存储单元 (120) ，用于存储多个参考位置信息，每个参考位置信息对应于多个目标对象;用户输入单元 (110) ，用于接收用于选择目标对象的输入信息 (220) ;超声数据获取单元 (130) ，被配置为向目标对象 (220) 发送超声信号和从目标对象 (220) 接收超声信号，从而输出超声数据;处理单元 (140) ，与存储单元 (120) ，用户输入单元 (110) 和超声数据获取单元 (130) 通信，处理单元 (140) ，用于形成3D超声图像 (210)) 基于超声数据并基于与输入信息对应的参考位置信息执行3D超声图像 (210) 的位置布置。

FIG. 1

