



(12) **EUROPEAN PATENT APPLICATION**
published in accordance with Art. 158(3) EPC

(43) Date of publication:
26.01.2005 Bulletin 2005/04

(51) Int Cl.7: **A61B 8/00**

(21) Application number: **03747204.0**

(86) International application number:
PCT/JP2003/004285

(22) Date of filing: **03.04.2003**

(87) International publication number:
WO 2003/090625 (06.11.2003 Gazette 2003/45)

(84) Designated Contracting States:
**AT BE BG CH CY CZ DE DK EE ES FI FR GB GR
HU IE IT LI LU MC NL PT RO SE SI SK TR**

- **KANDA, Hiroshi**
Tokorozawa-shi, Saitama 359-1111 (JP)
- **OTAKE, Tsuyoshi**
Kashiwa-shi, Chiba 277-0055 (JP)
- **KIMURA, Tsuyoshi**
Kashiwa-shi, Chiba 277-0812 (JP)
- **HAYASHI, Tatsuya**
Kashiwa-shi, Chiba 277-0803 (JP)

(30) Priority: **26.04.2002 JP 2002126075**

(71) Applicant: **Hitachi Medical Corporation**
Tokyo 101-0047 (JP)

(74) Representative: **Strehl Schübel-Hopf & Partner**
Maximilianstrasse 54
80538 München (DE)

(72) Inventors:
• **OKADA, Kazutaka**
Noda-shi, Chiba 278-0055 (JP)

(54) **ULTRASONOGRAPH**

(57) An ultrasound diagnostic apparatus includes an ultrasound probe, a transmission unit for transmitting an ultrasound signal to an object to be examined via the ultrasound probe, a reception unit for processing a signal received by the ultrasound probe, and an image generating unit for generating an image on the basis of the received signal processed by the reception unit, wherein the transmission unit has a function of transmitting the ultrasound signals with varying frequency plural time in

an identical direction at time intervals, this ultrasound signal transmitted plural times includes a first waveform in which a frequency increases and a second waveform in which a frequency decreases, and the reception unit has a function of phasing and adding received signals respectively corresponding to the first waveform and the second waveform, whereby in the tissue harmonic imaging, the penetration is improved while the resolution is maintained.

Fig.3a

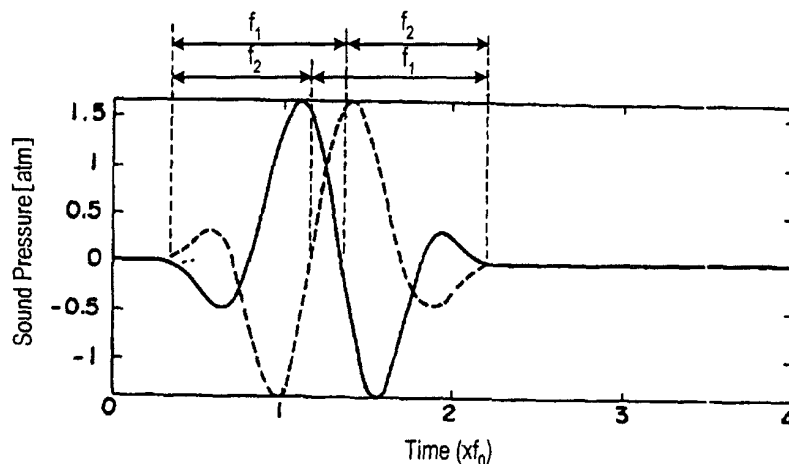

Description

Technical Field

[0001] The present invention relates to an ultrasound diagnostic apparatus, more particularly to an ultrasound diagnostic apparatus for imaging a harmonic component generated when an ultrasound is propagated inside a body of an object to be examined.

Background of the Invention

[0002] An ultrasound diagnostic apparatus is designed to transmit an ultrasound signal inside an object to be examined and to obtain information available in diagnosis, e.g. a tomographic image on the basis of a received signal including an echo signal of the transmitted signal.

[0003] It is reported that in the technique of displaying the tomographic image, a high-contrast image can be obtained by imaging a harmonic component (e.g. frequency $2f_0$ or $3f_0$) as opposed to a fundamental component (frequency f_0) of transmitted signal. An imaging method of this type is referred to as "Tissue Harmonic Imaging."

[0004] The above described harmonic component is generated due to nonlinear distortion occurring mainly when the ultrasound is propagated inside the object. That is, a signal of the ultrasound irradiated to the inside of living body is distorted during propagation in a tissue due to nonlinear response of tissue, and the harmonic component is increased. As a result, the echo signal includes, e.g. a double frequency $2f_0$ and a triple frequency $3f_0$ of a fundamental component f_0 .

[0005] In the tissue harmonic imaging, it is important how to extract an echo of strong harmonic component. The conventionally reported methods of tissue harmonic imaging include one referred to as "filtering technique" as an example.

[0006] This technique is designed to extract the harmonic component of e.g. $2f_0$ from a received signal using a band pass filter with a central frequency of e.g. $2f_0$. Another example is a method referred to as "pulse inversion technique," which is designed to emphasize the second harmonic component by transmitting a first and second waveforms having a mutually alternated polarity at time intervals, and phasing and adding the echo signals thereof to cancel the fundamental component. Further, for example, Japanese Unexamined Patent Publication No.2002-34976 discloses a technique of extracting a harmonic component through a filter from received signals obtained from transmitted signals having two different center frequencies, and widening the band of the harmonic component by combining those extracted signals, thus improving a resolution and enhancing a signal strength in a beam depth direction, and suppressing generation of motion artifact. However, because the frequency of the harmonic component in an ultrasound sig-

nal is higher than that of the fundamental component, the harmonic component is sensitive to attenuation of the signal during propagation. Accordingly, a degree of echo signal from a deep portion, i.e. a penetration is undesirable. Meanwhile, when the center frequency f_0 of the fundamental component is lowered, the echo signal is scarcely affected by the attenuation, whereby the penetration can be improved. However, the resolution is deteriorated, as is generally known.

Summary of the Invention

[0007] The present invention is done in consideration of the above, and an object thereof is to improve the penetration while maintaining the resolution.

[0008] To achieve the above object, an ultrasound diagnostic apparatus according to the present invention includes an ultrasound probe, a transmission unit for transmitting an ultrasound signal to an object to be examined via the ultrasound probe, a reception unit for processing a signal received by the ultrasound probe, and an image generating unit for generating an image on the basis of the received signal processed by the reception unit, wherein the transmission unit has a function of transmitting the ultrasound signal having a varying frequency plural times in one direction at time intervals, this ultrasound signal transmitted plural times includes a first waveform in which the frequency increases and a second waveform in which the frequency decreases, and the reception unit has a function of phasing and adding received signals corresponding to the first waveform and the second waveform.

[0009] According thereto, in comparison with a conventional case where a waveform having frequency f_0 is transmitted while its polarity is alternated, a frequency spectrum of the received signal after phasing and addition changes, thereby a component in a frequency band between f_0 and $2f_0$ can be emphasized. Because the component in this frequency band has a frequency lower than $2f_0$, it is scarcely affected by attenuation, and so the penetration is desirable. Accordingly, by extracting this frequency component to generate an image based thereon, the penetration in the tissue harmonic imaging can be improved without lowering f_0 , i.e. lowering the resolution.

[0010] Here, the waveform having a varying frequency may be formed by, e.g. joining each one cycle or a plurality of cycles of waveforms having different frequencies. Alternatively, it may be formed by joining parts of $1/2$, $1/4$, or $1/8$ cycle of the waveforms having different frequencies, or a chirp waveform in which the frequency sequentially changes may be used.

[0011] In this case, the above described frequency spectrum is varied by variably setting a change rate of frequency variation of the first waveform and the second waveform. Here, particularly when diagnostic information is acquired from a deep portion inside the object (portion distant from the probe), the frequency spectrum

of received signal is desirably shifted to be low in consideration of the penetration. Then, it is desirable that the transmission unit has a function of variably setting a transmission focus depth and the change rate of frequency variation of the first waveform and the second waveform is variably set depending on the transmission focus depth.

[0012] Further, in this case, when the first waveform and the second waveform respectively shift so that their signal strengths decrease, the above described spectrum variation can be emphasized. At this time, it is also desirable that the change rate of the signal strengths of the first waveform and the second waveform is variably set depending on the transmission focus depth.

[0013] Further, it is also desirable that the polarities of the first waveform and the second waveform are mutually alternated, and the reception unit has a function of phasing and adding the reception signals corresponding to the first waveform and the second waveform after amplifying or attenuating them with a gain difference.

[0014] Even when the above manner is utilized, the frequency spectrum of the received signal after phasing and addition changes and the component in the frequency band between f_0 and $2f_0$ can be emphasized, whereby the penetration can be improved without lowering f_0 , i.e. lowering the resolution. In this case, the gain difference may be variably set depending on a reception timing, i.e. a reception focus depth. For instance, it is desirable that the reception signals corresponding to the first waveform and the second waveform are subjected to a time gain control with different correlation curves between reception timing and gain.

[0015] Further, the reception unit may have a function of performing a reception focus processing on the received signal and a filter for extracting a predetermined frequency band of the received signal, in which the frequency band is variably set depending on the predetermined reception focus depth. According thereto, it is possible to adapt to the spectrum variation of the received signal occurring due to the difference of reception focus depth, i.e. the difference in depth of the portion examined. inside the object, and to extract a component in a preferable frequency band.

[0016] Further, in the case where the change rate of varying frequency or signal intensity of the first waveform and the second waveform according to the predetermined transmission focus depth is variably set, a frequency band of the filter may be variably set in accordance with the transmission focus depth in order to adapt to the spectrum variation of received signal caused by varying the frequencies or the signal intensities as above.

Brief Description of the Drawings

[0017] Fig.1 is a diagram showing a structure of an ultrasound diagnostic apparatus according to a first embodiment of the present invention. Fig.2 is a graph pre-

senting the simulation results of waveforms of transmitted signal and spectrums of transmitted signal and received signal based on a conventional pulse inversion method. Fig.3 is a graph presenting the simulation results of waveforms of transmitted signal and spectrums of transmitted signal and received signal in the ultrasound diagnostic apparatus of Fig.1. Fig.4 is a schematic diagram showing variation of a reception spectrum occurring due to a depth of received signal generation. Fig.5 is a graph presenting the simulation results of waveforms of transmitted signal and spectrums of transmitted signal and received signal in an ultrasound diagnostic apparatus according to a second embodiment of the present invention. Fig.6 is a diagram showing a structure of an ultrasound diagnostic apparatus according to a third embodiment of the present invention. Fig.7 is a graph presenting the simulation results of spectrums of transmitted signal and received signal in the ultrasound diagnostic apparatus according to the third embodiment of the present invention. Fig.8 is a graph presenting the simulation results of spectrums of transmitted signal and received signal in the ultrasound diagnostic apparatus according to the third embodiment of the present invention. Fig.9 is a graph showing the simulation results of spectrums of transmitted signal and received signal in the ultrasound diagnostic apparatus according to the third embodiment of the present invention.

Best Mode for Carrying out the Embodiment

Embodiment 1

[0018] Hereinafter, an ultrasound diagnostic apparatus according to the first embodiment of the present invention will be described. Fig.1 is a diagram showing the structure of the ultrasound diagnostic apparatus according to this embodiment. As shown in Fig.1, the ultrasound diagnostic apparatus includes ultrasound probe 1, transmission unit 3 for transmitting an ultrasound signal to an object to be examined (not shown in the figure) via ultrasound probe 1, reception unit 5 for receiving a received signal including an echo signal from the object via ultrasound probe 1 and processing the received signal, and image producing/display unit 7 for generating and displaying a diagnostic image on the basis of the received signal processed by reception unit 5. Image producing/display unit 7 includes a video processing unit for performing detection, compression, and the like, a Doppler processing unit, and a scan converter, which are not shown in the figure.

[0019] Transmission unit 3 includes arbitrary waveform generator 9 having a function of generating a transmitted signal combining a plurality of waveforms respectively having predetermined amplitude, frequency, and starting phase, time axis controller 11 having a function of time-inverting the waveform output by arbitrary waveform generator 9, and transmitter 13 having a power amplifier, for supplying a driving signal to ultrasound probe

1 in response to an output signal of time axis controller 11. Meanwhile, time axis controller 11 has a so-called first-in/first-out function and a first-in/last-out function using the output of arbitrary waveform generator 9 as an input signal, and has a shift register for these functions.

[0020] Reception unit 5 is input a received signal output from ultrasound probe 1, which includes receiver 15 having a pre-amplifier, a time gain control (TGC) amplifier, and an A/D converter which are not shown in the figure, phasing/addition unit 17 for phasing and adding received signals of channels output by receiver 15 corresponding to the respective transducers of ultrasound probe 1 and outputting the added signals as an RF line signal, line adder 19 for keeping the received signal previously output from phasing/addition unit 17, RF-adding it and a time-delayed received signal output afterward from phasing/addition unit 17 in consideration of their phase, and outputting the resultant signal, and band pass filter 21 having a function of band pass digital filter calculation for extracting a particular frequency band signal from among the output signals of line adder 19. A so-called digital beam former is used as phasing/addition unit 17 to minimize distortion occurring in the addition processing. Further, system controller 23 for totalizing and controlling operations of each component in transmission unit 3, reception unit 5, and image producing/display unit 7 described above is provided. Further, ultrasound probe 1 includes a plurality of transducers 25 arranged to face the object (not shown) in a line or in a plane.

[0021] Next, the operation of the above described ultrasound diagnostic apparatus will be described. First, arbitrary waveform generator 9 generates and outputs a waveform of transmitted signal on the basis of a command from system controller 23. The waveform of signal output by arbitrary waveform generator 9 is formed by combining waveforms in which the frequency is time-sequentially varied. This point will be described later in detail. A signal output by arbitrary generator 9 is input to time axis controller 11. And the first waveform is output without time-inverted by the first-in/first-out function. After that, time axis controller 11 outputs a second waveform having a waveform formed by inverting the first waveform symmetrically about a line perpendicular to a time axis by the first-in/last-out function with a time delay to the first waveform. Transmitter 13 performs a known transmission focus processing on the basis of the first waveform and the second waveform and generates and outputs a driving signal to each transducer 25 of ultrasound probe 1. Transducer 25 supplied the driving signal from transmitter 13 via a transmission/reception separating circuit (not shown) is respectively oscillated to generate an ultrasound wave, and an ultrasound beams proceeding in a direction in which wave surfaces of the respective ultrasound waves transmitted by transducers 25 coincide with each other are formed inside the object (not shown).

[0022] On the other hand, the ultrasound signal propagating inside the object as the ultrasound beam are reflected at a portion having a different acoustic impedance inside the object. The reflected signals return to ultrasound probe 1 and are received as a received signal. The received signals are converted from sound waves into electric signals by transducer 25 and input to receiver 15 via the transmission/reception separating circuit (not shown). In receiver 15, the received signal of a channel corresponding to each transducer 25 is amplified by the pre-amplifier and the TGC amplifier, A/D converted, and output. A signal output from receiver 15 is input to phasing/addition unit 17, subjected to a known dynamic focus processing for sequentially correcting variation of reception timing of received signal between the respective channels occurring due to difference in the distance from a generating portion of received signal to each transducer 25, and the processed signals are added and output. Those processings concerning the ultrasound reception are performed on each of received signals corresponding to the first waveform and the second waveform. The received signals corresponding to the first waveform and the second waveform are combined by line adder 19 temporarily keeping and time-delaying the received signal corresponding to the first waveform and adding it and the received signal corresponding to the second waveform, and output as a combined received signal. In band pass filter 21, a component of the predetermined frequency band of the combined received signal is extracted. And image producing/display unit 7 generates and displays an ultrasound diagnostic image on the basis of a signal of the extracted frequency band component. That is, the ultrasound diagnostic apparatus conducts the above operations while performing scans in the beam direction, and image producing/display unit 7 performs video processings including the detection and the compression, a Doppler signal processing, a scan conversion and the like to produce a known B-mode or Doppler-mode image. Meanwhile, system controller 23 not only controls the above series of operations but also generates data for arbitrary waveform generator 9.

[0023] Next, the first waveform, the second waveform, and the frequency spectrums of transmitted signal and received signal according to this embodiment will be described. First, for easy understanding of the characteristics of this embodiment, the simulation results of the first waveform, the second waveform, and the frequency spectrums of transmitted signal and received signal in the conventional pulse inversion method, which are shown in Fig.2, will be described. Fig.2a is a graph presenting the first waveform and the second waveform, in which a horizontal axis indicates time and a vertical axis indicates sound pressure of transmitted wave. Here, the first waveform is presented by a full line and the second waveform is presented by a broken line. As shown in Fig.2a, both the first waveform and the second waveform are sequences of sine waves for two cy-

cles having the same frequency f_0 (2MHz), to both of which a Hanning weight is applied to simulate a waveform in a living body. The polarity of the first waveform is opposite to that of the second waveform. That is, the sound pressure decreases at the start of signal with the polarity of the first waveform, and with the polarity of the second waveform the sound pressure increases.

[0024] Fig.2b is a graph presenting the frequency spectrum of transmitted signal and received signal obtained by phasing and adding the received signals corresponding to the first waveform and the second waveform. In the graph, the horizontal axis indicates a frequency ratio (f/f_0) in relation to $f_0=2.0\text{MHz}$ and the vertical axis indicates signal strength (dB). In Fig.2b, the spectrum of transmitted signal is presented by a broken line and that of combined reception signal is presented by a full line.

[0025] As shown in Fig.2b, in the spectrum of transmitted signal, the signal strength increases when the frequency increases from 0 and has its first peak at frequency f_0 where it becomes maximal. And when the frequency further increases, the signal strength then decreases and becomes -40dB of the first peak at frequency $2f_0$. When frequency further increases from frequency $2f_0$, the signal strength again increases and has its second peak in the vicinity of frequency $2.3f_0$, and again decreases after that. The signal strength of the second peak is approximately -32dB of the first peak.

[0026] Meanwhile, the spectrum of combined reception signal has its peaks where the signal strength becomes maximal in the vicinity of $0.6f_0$, $2f_0$, and $4f_0$, and has its nadirs where the signal strength becomes minimal in the vicinity of $1.2f_0$ and $3.3f_0$. Among the peaks, the signal strength is maximized at the peak in the vicinity of $2f_0$, and the both signal strengths at the peaks in the vicinity of $0.6f_0$ and $4f_0$ are -14dB of the signal strength at the peak in the vicinity of $2f_0$. On the other hand, the signal strengths at the nadirs in the vicinity of $1.2f_0$ and $3.3f_0$ where the signal strength becomes minimal are respectively about -28dB and -21dB of that at the peak at $2f_0$.

[0027] Next, one example of the first waveform and the second waveform having varying frequencies and the frequency spectrums of transmitted signal and received signal in the ultrasound diagnostic apparatus according to this embodiment will be described with reference to the simulation results shown in Fig.3. Fig.3a is a graph showing the first waveform and the second waveform, where the horizontal axis indicates time and the vertical axis indicates sound pressure. Here, the first waveform is presented by a full line and the second waveform is presented by a broken line. As shown in Fig.3a, the first waveform is formed by joining a first cycle of frequency $f_1(=1.8\text{MHz})$ and a second cycle of frequency $f_2(=2.2\text{MHz})$ with a polarity in which the sound pressure increases at the start of signal. On the other hand, the second waveform is formed by joining a first cycle of frequency f_2 and a second cycle of frequency

f_1 , in which the waveform shifts at a certain change rate between those cycles, and with a polarity in which the sound pressure decreases at the start of signal. Furthermore, a Hanning weight similar to the waveform shown in Fig.2a is applied to both those first and second waveforms. In other words, the second waveform is formed by time-inverting the first waveform.

[0028] Fig.3b is a graph showing the frequency spectrums of transmitted signal and received signal obtained by phasing and adding received signals corresponding to the first waveform and the second waveform, wherein the horizontal axis indicates frequency ratio (f/f_0) in relation to $f_0=2.0\text{MHz}$ and the vertical axis indicates signal strength(dB) as in Fig.2. In the graph of Fig.3(b), the spectrum of transmitted signal is presented by a broken line and that of received signal obtained by phasing and addition is presented by a full line.

[0029] As shown in Fig.3b, in the spectrum of transmitted signal, the signal strength increases when the frequency increases from 0 and has its peak where it becomes maximal at frequency f_0 . When the frequency further increases, the signal strength decreases. After a decreasing rate of signal strength becomes small in the vicinity of frequency $2f_0$ and then becomes 0, the signal strength again decreases while the decreasing rate increases. Meanwhile, the signal strength in the vicinity of frequency $2f_0$ is approximately -23dB to the peak at frequency f_0 .

[0030] On the other hand, in the spectrum of phased and added received signal, the signal strength has its peaks where it becomes maximal in the vicinity of $0.4f_0$, $1.6f_0$, and $2.8f_0$, and has its nadirs where it becomes minimal in the vicinity of $0.7f_0$, $2.2f_0$, and $3.7f_0$. Among the peaks where the signal strength becomes maximal, the signal strength is maximized at the peak in the vicinity of $1.6f_0$. The signal strengths at the peaks in the vicinity of $0.4f_0$ and $2.8f_0$ are respectively about -12dB and -2dB of the signal strength at the peak at $1.6f_0$. Meanwhile, among the nadirs where the signal strength becomes minimal, the signal strength is approximately -14dB in the vicinity of $0.7f_0$, -17dB in the vicinity of $2.2f_0$, and -35dB in the vicinity of $3.7f_0$.

[0031] As is clear from the comparison of Fig.3b with Fig.2b, in the conventional pulse inversion method, a frequency component in the vicinity of $2f_0$ is most emphasized when the received signals corresponding to the first waveform and the second waveform are combined. Meanwhile, the peak of signal strength comes into the vicinity of $1.6f_0$ by differently determining f_1 and f_2 , and the frequency spectrum thus shifts to be low.

[0032] Further, in the ultrasound diagnostic apparatus according to this embodiment, a difference $\Delta f(=|f_1-f_2|)$ between frequencies f_1 and f_2 is variably set depending on the predetermined transmission focus depth. Specifically, Δf is variably set so that the frequency spectrum of the signal combining the received signals corresponding to the first waveform and the second waveform shifts to be low as the transmission focus depth

becomes deep. Meanwhile, an average frequency of the frequencies f_1 and f_2 is fixed to be f_0 . When the transmission focus depth is shallow, the transmission and reception are performed while Δf is set to be 0 as in the conventional pulse inversion method. Δf is varied as the transmission focus depth becomes deep and a transmitted wave is generated so that the above mentioned peak of frequency spectrum shifts from $2f_0$ to e.g. f_0 , desirably from $2f_0$ to, e.g. $1.5f_0$. For example, in the case of performing multiple transmission focus to complete a received signal for one beam line by combining a plurality of ultrasound beams having different transmission focus depths, Δf is variably set depending on a focus depth of each beam. For example, when the focusing is done on three points, Δf on each point is set so that the peaks of its frequency spectrum are at e.g. $2f_0$, $1.8f_0$, and $1.6f_0$ in the ascending order of focus depth. This setting of Δf depending on the transmission focus depth can be done by simulation or experiment using an ultrasonic phantom.

[0033] Further, in the ultrasound diagnostic apparatus according to this embodiment, a frequency pass band of band pass filter 21 is variably set depending on the variation of the above described frequency spectrum. Specifically, in order to adapt to the spectrum shift of received signal after phasing and addition, the frequency pass band is shifted to be low as the transmission focus depth becomes deep.

[0034] Further, the frequency pass band of band pass filter 21 is variably set depending on the reception focus depth even when the transmitted signal is not changed. Fig.4 is a schematic diagram showing a reception spectrum of signal received from a shallow portion of the object, i.e. a portion close to the ultrasound probe, and that of signal received from a deep portion of the object, i.e. a portion distant from the ultrasound probe. In Fig.4, only $2f_0$ is presented as a harmonic component for easy understanding. Since the transmitted signal is a pulse wave having usually a few cycle, the spectrum has a certain degree of band around f_0 and $2f_0$ in Fig.4. As shown in Fig.4, in the spectrum of received signal from the deep portion, the harmonic component is increased by a nonlinear distortion occurring when the ultrasound propagates in the living body. However, in the spectrum distribution of the harmonic component, the frequency spectrum shifts to be low and a center frequency lowers because a higher frequency component is more sensitive to the attenuation in propagation. Therefore, to deal therewith, the frequency pass band of band pass filter 21 is set to shift to be low as the reception focus depth becomes deeper in conjunction with the dynamic focusing in reception. Specifically, in the case of using a digital FIR filter as band pass filter 21, its coefficient is desirably set variably in conjunction with the reception focus depth.

[0035] As described above, according to this embodiment, by phasing and adding the received signals respectively corresponding to the first waveform in which

the frequency shifts to increase and the second waveform in which the frequency shifts to decrease, the frequency component in the band between f_0 and $2f_0$ is emphasized. Accordingly, the waveform is less affected by the attenuation than in the conventional pulse inversion method of emphasizing $2f_0$, whereby the penetration can be improved in a deep portion of focus. Besides, since the $2f_0$ component is imaged, the resolution can be maintained in shallow portion.

[0036] Further, since the change rate of frequencies variation of the first waveform and the second waveform is variably set depending on the transmission focus depth, it is possible to emphasize a relatively high-frequency component at a shallow focus depth in consideration of contrast and to emphasize a relatively low frequency component at a deep focus depth in consideration of penetration, whereby a desirable image can be produced depending on the predetermined transmission focus depth.

[0037] Further, a frequency band pass filter calculation is performed on the received signal after phasing and addition to variably set the frequency pass band depending on the transmission focus depth, whereby the frequency band to be emphasized can be extracted in response to the change rate of frequency variation of transmitted wave.

[0038] Further, since the frequency pass band is variably set also depending on the reception focus depth, a frequency band can be extracted in response to the spectrum variation of received signal occurring due to difference in attenuation of the signal caused by difference in propagation distance.

[0039] Further, for example, when a relatively shallow portion where the penetration is not a critical problem is examined, an image may be produced by extracting a component of frequency higher than $2f_0$. For example, although in Fig.3b there is a peak also in the vicinity of $2.8f_0$, a signal strength at the peak where the frequency is larger than $2f_0$ may be extracted using a band pass filter and used in image generation. According thereto, a desirable image contrast can be obtained when the shallow portion is examined.

[0040] Further, when the shallow portion is examined, the center frequency of transmitted signal may be set to be high. In the example of Fig.3, the center frequency is set as $f_0=2.0\text{MHz}$ and the first waveform and the second waveform are $f_1=1.8\text{MHz}$ and $f_2=2.2\text{MHz}$, respectively. However, they may be set as that the center frequency $f_0=2.1\text{MHz}$, $f_1=2.0\text{MHz}$, and $f_2=2.2\text{MHz}$. According thereto, a high-contrast image can be obtained at a relatively shallow depth where the penetration is not a problem.

[0041] Meanwhile, according to the above described embodiment, the second waveform is obtained by time-inverting the first waveform with the time axis controller. However, when the arbitrary waveform generator can directly generate the second waveform, the time axis controller is unnecessary.

[0042] Further, according to the above described embodiment, the first waveform and the second waveform are respectively formed by joining waveforms for two cycles. However, they may be formed by joining waveforms for three or more cycles. For example, the first waveform may be formed by joining each one cycle of waveforms of $f_1=1.8\text{MHz}$, $f_2=2.0\text{MHz}$, and $f_3=2.2\text{MHz}$, and the second waveform may be obtained by time-inverting the first waveform. In this manner, when the first waveform is a combination of each one cycle of the center frequency $f_1, f_2, \dots, f_n, \dots, f_N$ ($N \geq 2$), where $f_1 < f_2 < \dots < f_n < \dots < f_N$, and the second waveform is an inversion of the first waveform relative to the time axis, the effect of the invention is not lost even if $N=4$. However, because the difference between those two transmission waves becomes relatively small when the wave number increases, it can be thought that the invention is especially effective when $N < 6$.

[0043] Further, according to the above described embodiment, the first waveform and the second waveform are formed by combining sine waves in which the frequency is varied at every one cycle. However, the frequency may be varied at every two or more cycles. Alternatively, it may be frequently changed such as at every $1/2$ cycle or $1/4$ cycle, or may be a so-called chirp waveform in which the frequency sequentially changes.

Embodiment 2

[0044] Next, the second embodiment of the ultrasound diagnostic apparatus according to the present invention will be described. The same points as in the first embodiment will not be mentioned and only the points of difference will be described. The ultrasound diagnostic apparatus according to this embodiment is characterized in that the amplitude of both the first waveform and the second waveform is changed. That is, this embodiment is characterized in that the amplitude of waveform in the first cycle of the first waveform and the second waveform is respectively preset to be larger than that of the subsequent waveform.

[0045] An example of the first waveform and the second waveform having varying frequency and amplitude and the frequency spectrum of transmitted signal and received signal will be described with reference to Fig. 5 showing the simulation results thereof. Fig.5a is a graph presenting the first waveform and the second waveform, in which a horizontal axis indicates time and a vertical axis indicates sound pressure. In the graph, the first waveform is presented by a full line and the second waveform is presented by a broken line. As shown in Fig.5a, the first waveform is formed by joining a first cycle of frequency $f_1(=1.8\text{MHz})$ and a second cycle of frequency $f_2(=2.2\text{MHz})$, and with its polarity the sound pressure decreases at the start of signal. On the other hand, the second waveform is formed by joining a first cycle of frequency f_2 and a second cycle of frequency f_1 , and with its polarity the sound pressure increases. In

both the first waveform and the second waveform, amplitude A_2 in the second cycle is set to be smaller than amplitude A_1 in the first cycle. For example, in the case of Fig.5a, the amplitude is set as $A_2=0.9A_1$.

[0046] Fig.5b is a graph presenting frequency spectrums of a transmitted signal and a received signal obtained by phasing and adding received signals respectively corresponding to the first waveform and the second waveform. Similar to Fig.2b, the horizontal axis indicates a frequency ratio (f/f_0) in relation to $f_0=2.0\text{MHz}$ and the horizontal axis indicates signal strength (dB). In Fig.5(b), spectrums of transmitted signal is presented by a broken line, and spectrums of phased and added received signal is presented by a full line.

[0047] As shown in Fig.5b, the spectrum of transmitted wave resembles that shown in Fig.3(2). However, the signal strength in the vicinity of frequency $2f_0$ is -25dB of the signal strength in the vicinity of f_0 .

[0048] On the other hand, the spectrum of the phased and added received signal has its peaks where it becomes maximal in the vicinity of $0.4f_0$, $1.6f_0$, and $2.8f_0$, and has its nadirs where it becomes minimal in the vicinity of $0.7f_0$, $2.2f_0$, and $3.8f_0$. Among the maximal peaks, the signal strength is maximized at the peak in the vicinity of $1.6f_0$. Compared therewith, the signal strengths at the peaks in the vicinity of $0.4f_0$ and $2.8f_0$ are respectively about -13dB and -2dB . Meanwhile, the signal strengths at the nadirs in the vicinity of $0.7f_0$, $2.2f_0$, and $3.8f_0$ where the signal strength becomes minimal are respectively about -17dB , -10dB , and -40dB or less.

[0049] As is clear by comparing Fig.5b with Fig.2b, the peak of signal strength comes in the vicinity of $1.6f_0$ by shifting frequency f_1 and f_2 and shifting amplitude A_1 and A_2 , and the frequency spectrum shifts to be low.

[0050] Further, according to the frequency spectrum according to this embodiment, difference Δf between frequency f_1 and f_2 is variably set in response to a predetermined transmission focus depth and a ratio A_2/A_1 between amplitude A_1 and A_2 is also variably set. Specifically, as in the first embodiment, Δf and A_2/A_1 are variably set so that the frequency spectrum of a signal obtained by combining received signals corresponding to the first waveform and the second waveform shifts to be low as the transmission focus depth becomes deeper.

[0051] As described above, according to this embodiment, the spectrum shift of the phased and added received signal can be emphasized by shifting the amplitude of the first waveform and the second waveform in addition to the effect obtained by first embodiment described above.

Embodiment 3

[0052] Next, the third embodiment of the ultrasound diagnostic apparatus according to the present invention will be described. Here again, the same points as in the first embodiment will not be mentioned and only the

points of difference will be described.

[0053] Fig.6 is a diagram showing a structure of an ultrasound diagnostic apparatus according to this embodiment. As shown in Fig.6, the ultrasound diagnostic apparatus includes ultrasound probe 31 having a plurality of ultrasound transducers or an ultrasound transducer array (not shown), pulse inversion control unit 33 for controlling a signal transmitted to an object to be examined (not shown) via ultrasound probe 31, and transmitted wave phasing circuit 35 for generating a transmitted wave in response to a command from pulse inversion control unit 33 and driving ultrasound probe 31. Transmission phasing circuit 35 has a transmission timing generating circuit, a transmission beam former circuit, and a transmission driver, which are not shown, and is designed to supply a high-pressure transmitted signal to ultrasound probe 31. At this time, the transmitted beam former circuit generates a beam forming signal for forming an ultrasound beam in a predetermined direction on the basis of the transmission timing signal generated by the transmission timing generating circuit. The beam forming signal includes a plurality of driving signals, each of which is given a time difference corresponding to the direction.

[0054] Further, the apparatus also includes reception phasing circuit 37 for phasing and adding the signals received from the object via the ultrasound probe at each channel of the plurality of ultrasound transducers, variable gain circuit 39 for amplifying or attenuating a signal output by reception phasing circuit 37 depending on a variably determined gain, and two beam adder unit 41 for temporarily storing an output signal of variable gain circuit 39 and phasing and adding it with a signal output by variable gain circuit 39 after a time interval. Further, the apparatus includes variable band pass filter 43 for performing the digital band pass filter calculation on the output signal of two beam adder unit 41, B-mode processing unit 45 for performing known B-mode image processings including detection, logarithmic compression, and enhance processing on the basis of the output signal of the variable band pass filter 43, DSC circuit 47, and monitor 49 for displaying an image of video signals output by DSC circuit 47. Further, the apparatus includes control unit 51 for controlling variable gain circuit 39 and variable band pass filter 43, and is connected to console 53 having an input means.

[0055] Meanwhile, variable gain circuit 39 has a function of performing a known time gain control with variable gains on the plurality of signals received at time intervals in accordance with instructions from pulse inversion control unit 33 and control unit 51. Further, variable band pass filter 43 has a reception dynamic filter function for variably setting a center frequency and a band width of frequency pass band depending on a reception depth on the basis of a time control signal generated by control unit 51.

[0056] Next, operations of the above described ultrasound diagnostic apparatus will be described. In the ul-

trasound diagnostic apparatus according to this embodiment, the first waveform and second waveform are similar to those shown in Fig.2a, i.e. the first waveform is formed by joining two waveforms of frequency f_0 and the second waveform is formed by time-inverting or polarity-inverting the first waveform as in the conventional pulse inversion method. In variable gain circuit 39, a time gain control is performed on received signals respectively corresponding to the first waveform and the second waveform in a reception timing of the received signals, i.e. with a gain (amplitude gain) different depending on the depth of detecting portion. After that, those received signals are phased and added by two beam adder unit 41 to be made into one RF signal.

[0057] Figs.7 to 9 are graphs showing the simulation results of the frequency spectrums of transmitted signal and combined received signal according to this embodiment, wherein the gain ratio between the received signals corresponding to the first waveform and the second waveform is 1:1, 1.2:0.8, and 1.35:0.65, respectively. In each figure, as in Fig.2b, the horizontal axis indicates a frequency ratio (f/f_0) in relation to $f_0=2\text{MHz}$ and the vertical axis indicates signal strength (dB). The spectrum of transmitted signal is represented by a broken line and that of received signal after phasing and addition is represented by a full line. Meanwhile, needless to say, the spectrum of transmitted signal here is the same as that shown in Fig.2b.

[0058] Next, the spectrum of received signal after phasing and addition in each figure will be described. Fig.7 shows the case where a ratio of gain (hereinafter referred to as "gain ratio") between received signals respectively corresponding to the first waveform and the second waveform is 1:1. As shown in Fig.7, the spectrum of received signal has its peaks where the signal strength becomes maximal in the vicinity of $0.6f_0$, $1.9f_0$, and $3.7f_0$. On the other hand, the spectrum has its nadirs where the signal strength becomes minimal in the vicinity of $1.1f_0$ and $2.9f_0$. The signal strength is maximized at the peak in the vicinity of $1.9f_0$. In relation to this maximum signal strength, the signal strengths at other peaks and at the nadirs are about -9dB, -25dB, -17dB, and -6dB respectively in the vicinity of $0.6f_0$, $1.1f_0$, $2.9f_0$, and $3.7f_0$.

[0059] Fig.8 shows the case where the gain ratio is 1.2:0.8. As shown in Fig.8, the spectrum of received signal has its peaks where the signal strength becomes maximal in the vicinity of $0.6f_0$, $1.9f_0$, and $3.7f_0$. On the other hand, the spectrum has its nadirs where the signal strength becomes minimal in the vicinity of f_0 and $2.9f_0$. The signal strength is maximized at the peak in the vicinity of $1.9f_0$. In relation to the maximum signal strength, the signal strengths at other peaks and at nadirs are about -8dB, -15dB, -13dB, and -5dB respectively in the vicinity of $0.6f_0$, f_0 , $2.9f_0$, and $3.7f_0$.

[0060] Fig.9 shows the case where the gain ratio is 1.2:0.8. As shown in Fig.9, the spectrum of received signal has its peak where the signal strength becomes

maximal in the vicinity of $0.6f_0$, $1.9f_0$, and $3.7f_0$. On the other hand, the spectrum has its nadirs where the signal strength becomes minimal in the vicinity of $0.9f_0$ and $2.9f_0$. The signal strength is maximized at the peak in the vicinity of $1.9f_0$. In relation to the signal strength at this time, the signal strengths at other peaks and at nadirs are -8dB, -9dB, -10dB, and -5dB respectively in the vicinity of $0.6f_0$, $0.9f_0$, $2.9f_0$, and $3.7f_0$.

[0061] As is clear by comparing among Fig.7 to Fig. 9, the spectrum of the phased and added received signal is varied by changing the gain ratio. For example, when the component in a frequency band between f_0 and $2f_0$ is focused attention, it is more emphasized in Fig.8 than in Fig.7, and further emphasized in Fig.9 than in Fig.8. Meanwhile, in relation to the peak at $1.9f_0$, the signal strength at $1.5f_0$ is about -7dB in Fig.7, -5dB in Fig.8, and -3dB in Fig.9.

[0062] Further, according to this embodiment, the gain ratio is variably set in accordance with a predetermined reception focus depth. Specifically, the gain ratio is set to be larger as the reception focus depth becomes deeper. This change of gain ratio is sequentially done in the reception timing in conjunction with a known reception dynamic focus. That is, the time gain control is performed with different correlation curves between the reception timing and the gain on the received signals respectively corresponding to the first waveform and the second waveform.

[0063] Further, variable band pass filter 43 variably sets a frequency pass band depending on a predetermined reception focus depth. Specifically, the frequency pass band is set to be wide and the center frequency is set to be low in an area where the reception focus depth is shallow, and thus a secondary harmonic component is passed through a wide band. As the reception focus depth becomes deeper and the fundamental component is more emphasized, the frequency pass band of the variable band pass filter is set to be narrow and a floor frequency is set to be high, thereby the fundamental component is reduced.

[0064] As described above, according to this embodiment, the polarities of the first waveform and the second waveform are mutually inverted, and the received signals corresponding to the first waveform and of the second waveform are amplified or attenuated with a gain difference. In this manner, the frequency spectrum of received signal after phasing and addition is varied and a component in the frequency band between f_0 and $2f_0$ can be emphasized, whereby the penetration can be improved without lowering F_0 and deteriorating the resolution.

[0065] Further, since the gain difference and the frequency pass band of the variable band pass filter are variably set depending on the reception focus depth, in a relatively shallow portion the secondary harmonic component can be emphasized by canceling the fundamental component by setting the gain difference to be small or 0, or by setting the frequency pass band of the

variable band pass filter to be wide. On the contrary, in a relatively deep portion, the penetration can be improved by setting the gain difference to be large, narrowing the frequency pass band, and setting the center frequency to be low.

[0066] Meanwhile, according to the above described embodiment, the gains of both received signals corresponding to the first waveform and the second waveform are variably set. However, it is also possible that one gain is fixed and only the other is variably set. For example, it is possible that the gain of the first waveform is fixed as 1 and only the gain of the second waveform is variably set. Alternatively, the gain ratio may be variably set in stages as 1:1, 1:0.6, and then 1:0.3. Further, in addition to or instead of varying the gain of received signal, an amplitude in transmission of the first waveform and the second waveform may be varied.

20 Claims

1. An ultrasound diagnostic apparatus comprising: an ultrasound probe; a transmission unit for transmitting an ultrasound signal to an object to be examined via the ultrasound probe; a reception unit for processing a signal received by the ultrasound probe; and an image generating unit for generating an image on the basis of the received signal processed by the reception unit, the transmission unit having a function of transmitting ultrasound signals including a first waveform and a second waveform having varying frequency plural times in an identical direction at time intervals, and the reception unit having a function of phasing and adding received signals respectively corresponding to the first waveform and the second waveform, wherein the transmission unit has a function of varying the first waveform so that the frequency time-sequentially increases and varying the second waveform so that the frequency time-sequentially decreases and/or the reception unit has a function of phasing and adding the received signals corresponding to the first waveform and the second waveform while amplifying or attenuating them with a gain difference.
2. An ultrasound diagnostic apparatus according to claim 1, wherein when the transmission unit has a function of varying the first waveform so that the frequency time-sequentially increases and varying the second waveform so that the frequency time-sequentially decreases, the shape of the first waveform and that of the second waveform are axisymmetrical about a line perpendicular to a time axis.
3. An ultrasound diagnostic apparatus according to claim 1, wherein when the transmission unit has a function of varying the first waveform so that the frequency time-sequentially increases and varying the

second waveform so that the frequency time-sequentially decreases, the transmission unit has a function of variably setting a transmission focus depth of the ultrasound signal, and a change rate of the varying frequencies of the first waveform and the second waveform is variably determined depending on the transmission focus depth.

4. An ultrasound diagnostic apparatus according to claim 1, wherein when the transmission unit has a function of varying the first waveform so that the frequency time-sequentially increases and varying the second waveform so that the frequency time-sequentially decreases, the first waveform and the second waveform vary respectively so that the signal strength is reduced. 5
5. An ultrasound diagnostic apparatus according to claim 3, wherein when the transmission unit has a function of varying the first waveform so that the frequency time-sequentially increases and varying the second waveform so that the frequency time-sequentially decreases, the transmission unit has a function of variably setting a transmission focus depth, and at least either a change rate of varying frequency of the first waveform and the second waveform or a change rate of varying signal strength of the first waveform and the second waveform is variably determined depending on the transmission focus depth. 10
6. An ultrasound diagnostic apparatus according to claim 1, wherein when the reception unit has a function of phasing and adding the received signals corresponding to the first waveform and the second waveform while amplifying or attenuating them with a gain difference, the gain difference is variably set depending on a reception timing of the received signals. 15
7. An ultrasound diagnostic apparatus according to claim 1, wherein when the transmission unit has a function of varying the first waveform so that the frequency time-sequentially increases and varying the second waveform so that the frequency time-sequentially decreases, the reception unit has a filter for extracting a predetermined frequency band of the received signal, and the frequency band is variably set depending on the reception timing of the received signal. 20
8. An ultrasound diagnostic apparatus according to claim 1, wherein when the transmission unit has a function of varying the first waveform so as to time-sequentially increase the frequency and varying the second waveform so as to time-sequentially decrease the frequency, the frequency of the first waveform and/or the second waveform increases 25

or decreases at every two or more cycles.

9. An ultrasound diagnostic apparatus according to claim 1, wherein when the transmission unit has a function of varying the first waveform so that the frequency time-sequentially increases and varying the second waveform so that the frequency time-sequentially decreases, the frequency of the first waveform and/or the second waveform increases or decreases at every one or less cycle. 30
10. An ultrasound diagnostic apparatus according to claim 1, wherein when the transmission unit has a function of varying the first waveform so that the frequency time-sequentially increases and varying the second waveform so that the frequency time-sequentially decreases, the frequency of the first waveform and/or the second waveform continuously increases or decreases. 35

Fig.1

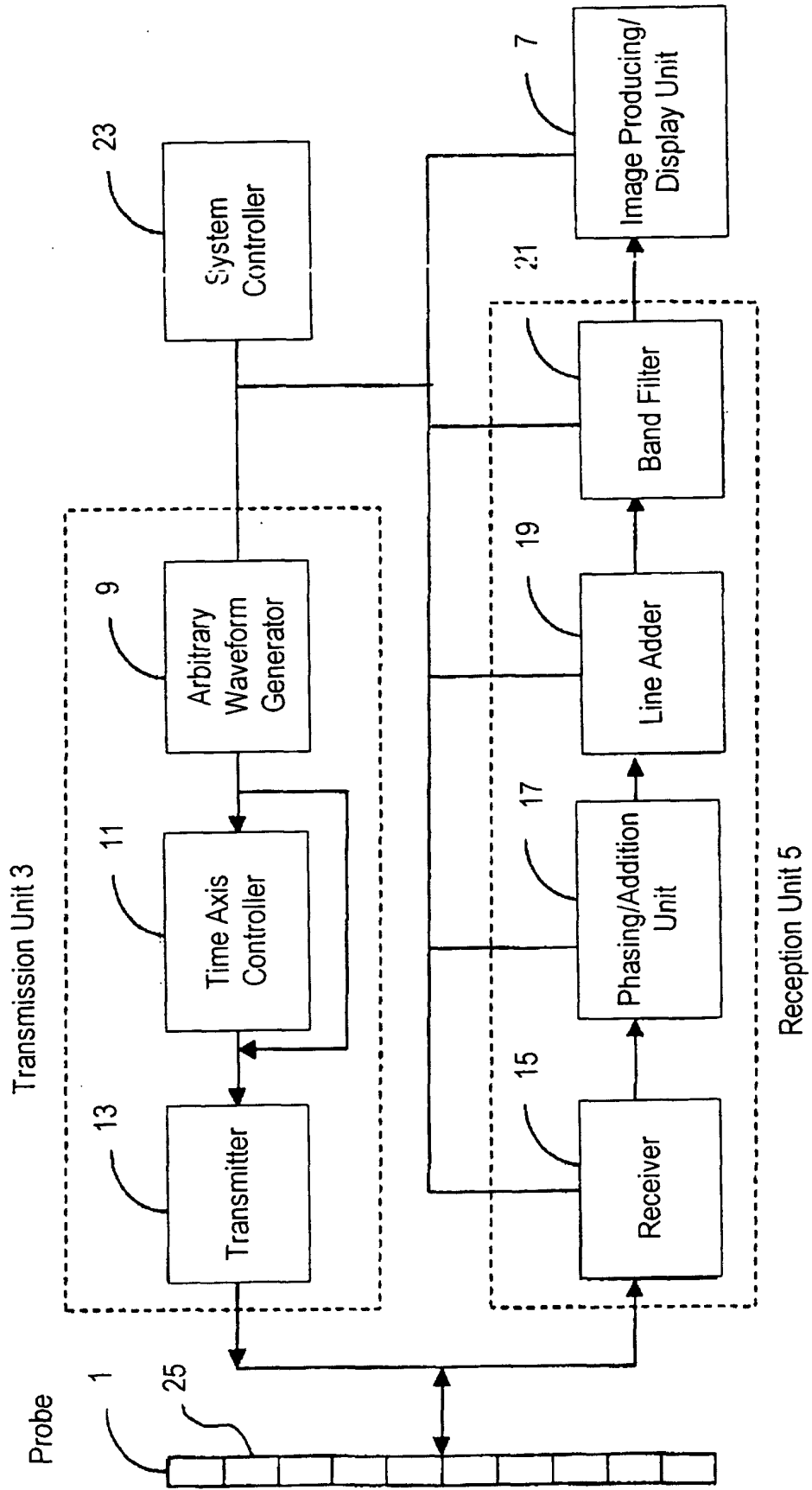

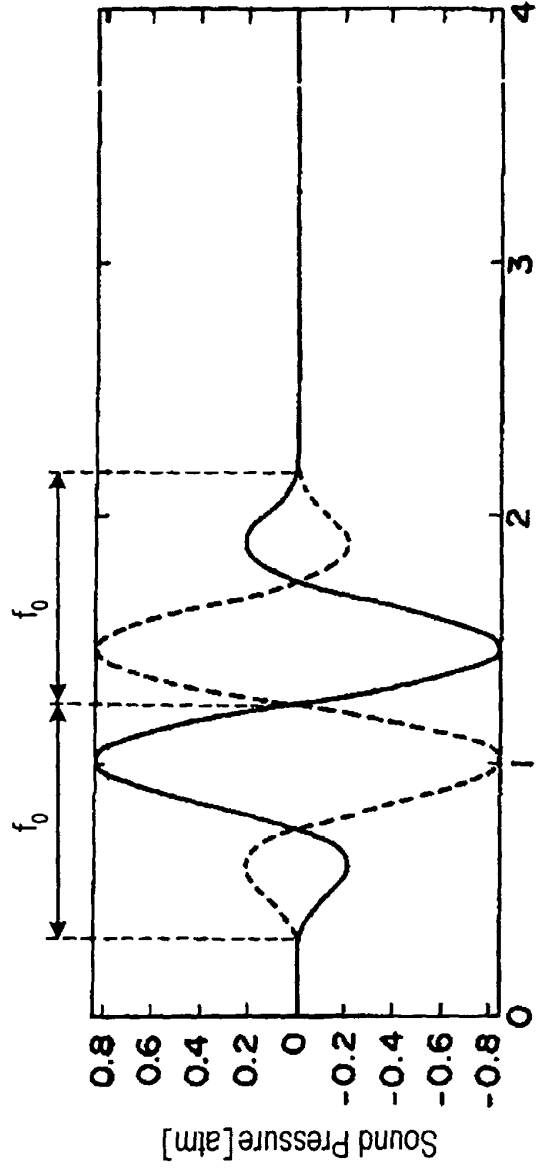

Fig.2a

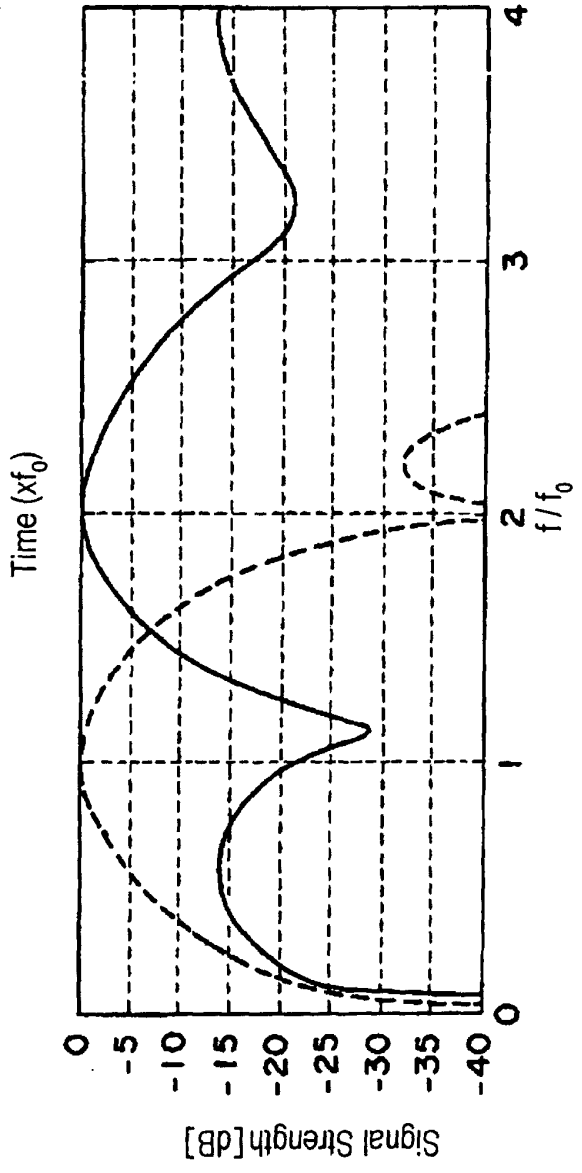

Fig.2b

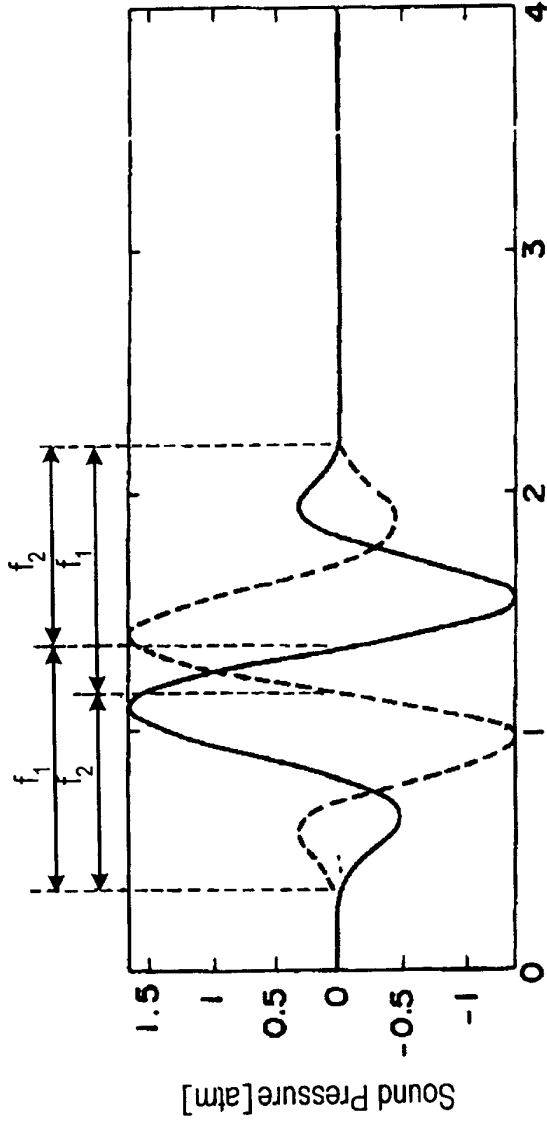

Fig.3a

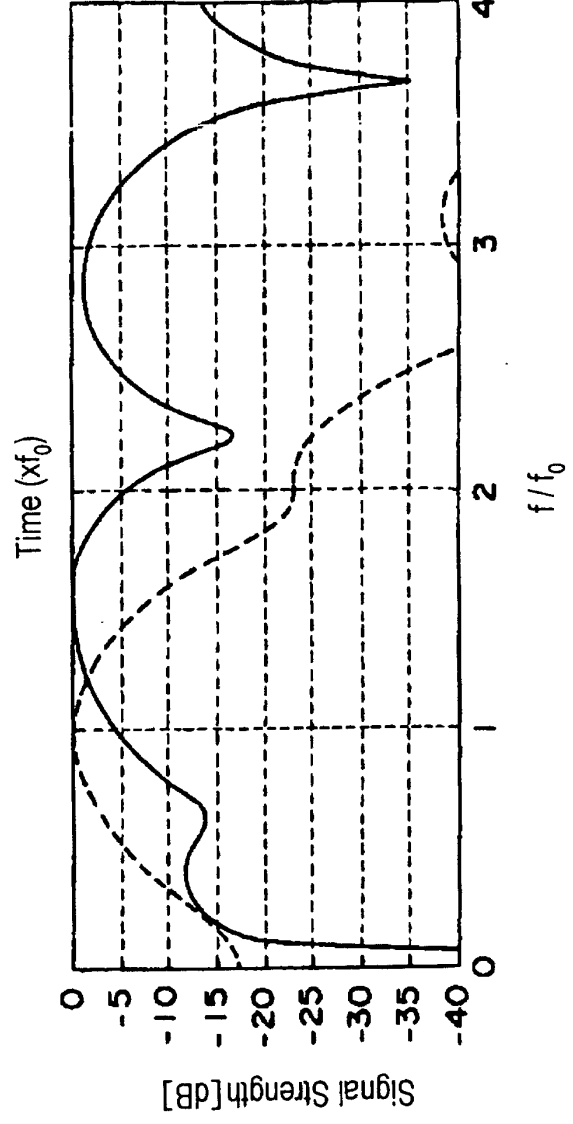

Fig.3b

Fig.4a

Reception from
Shallow Portion

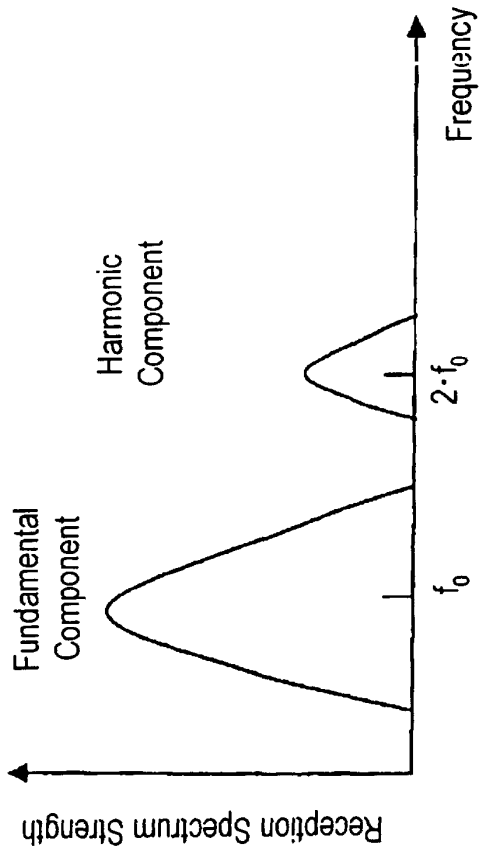

Fig.4b

Reception from
Deep Portion

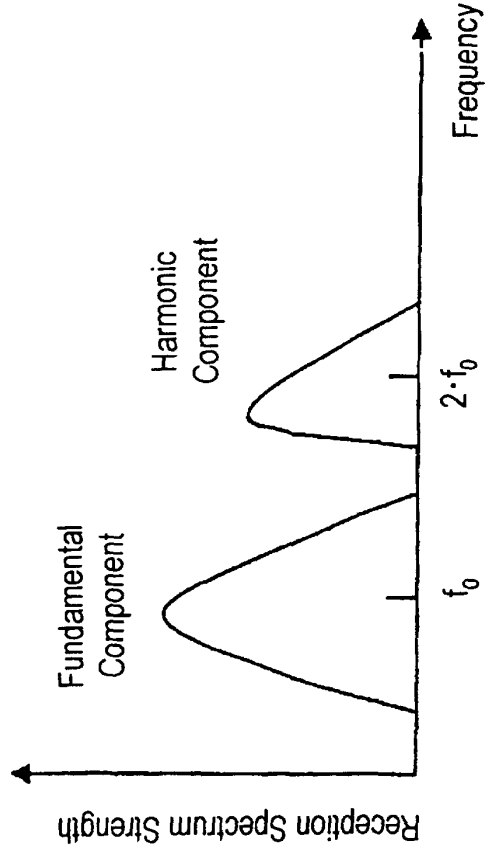

Fig.5a

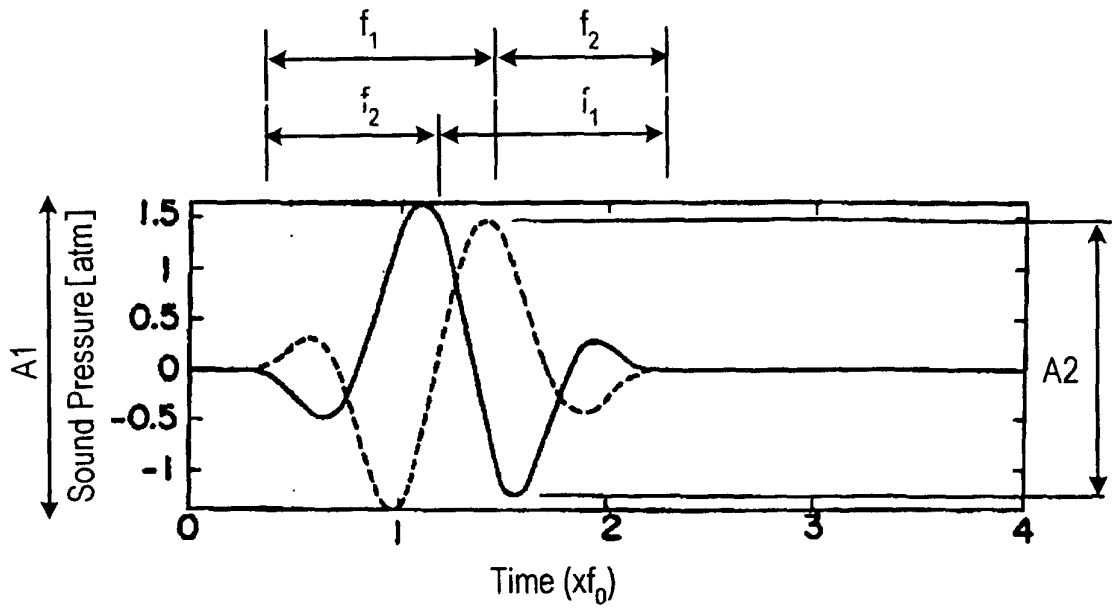

Fig.5b

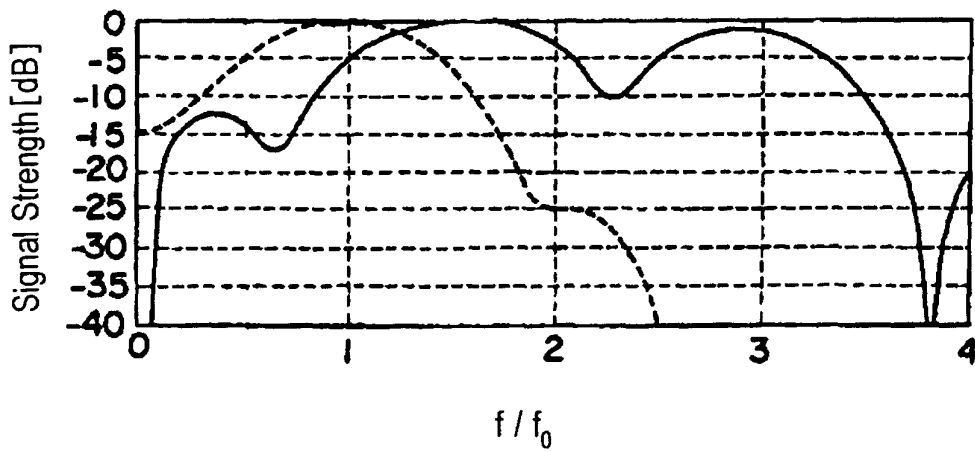

Fig.6

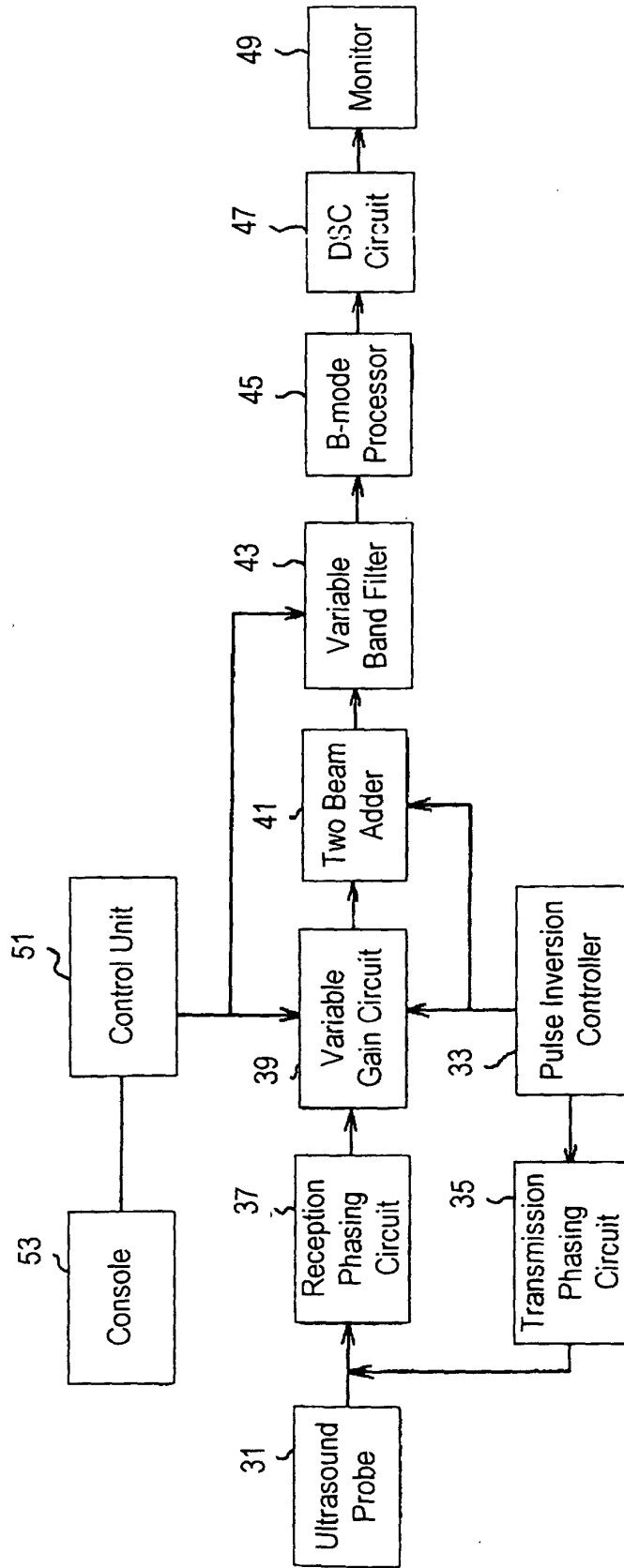

Fig.7

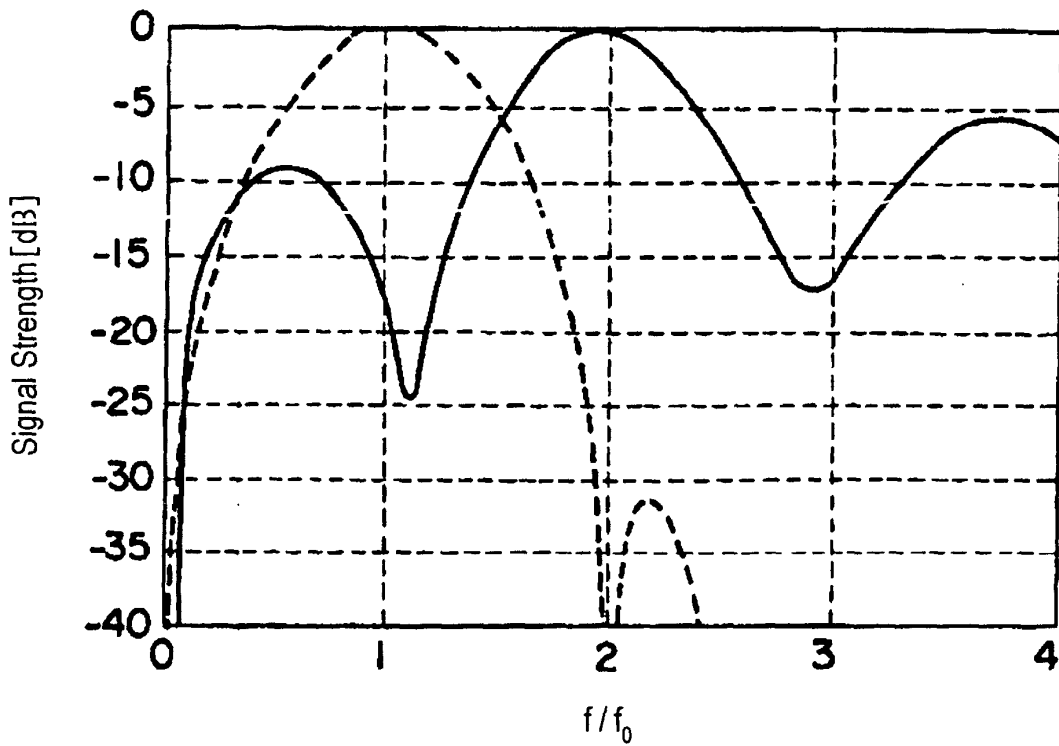

Fig.8

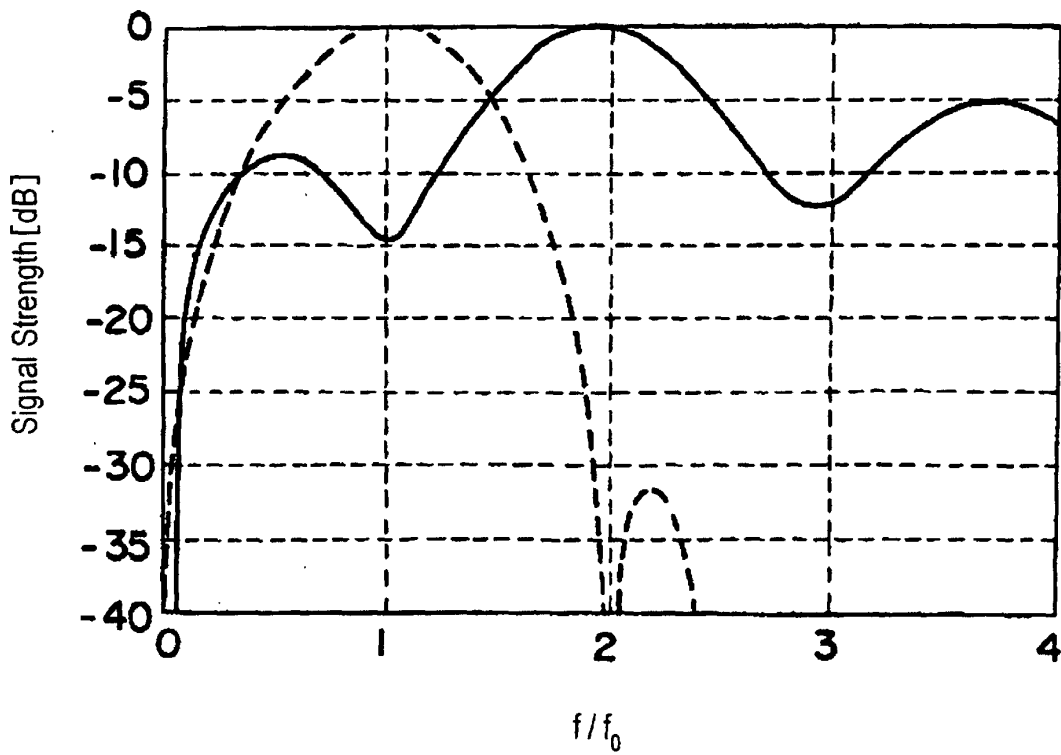
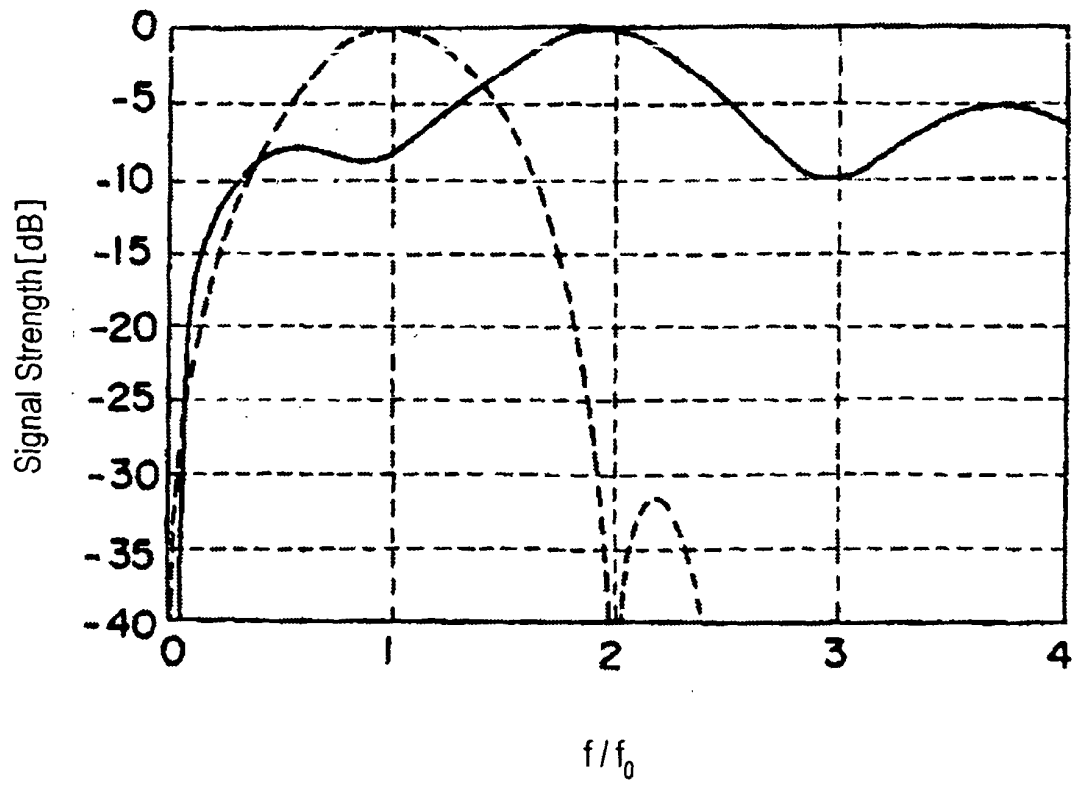

Fig.9



INTERNATIONAL SEARCH REPORT

International application No.

PCT/JP03/04285

A. CLASSIFICATION OF SUBJECT MATTER Int.Cl ⁷ A61B8/00		
According to International Patent Classification (IPC) or to both national classification and IPC		
B. FIELDS SEARCHED		
Minimum documentation searched (classification system followed by classification symbols) Int.Cl ⁷ A61B8/00-8/15		
Documentation searched other than minimum documentation to the extent that such documents are included in the fields searched Jitsuyo Shinan Koho 1922-1996 Toroku Jitsuyo Shinan Koho 1994-2003 Kokai Jitsuyo Shinan Koho 1971-2003 Jitsuyo Shinan Toroku Koho 1996-2003		
Electronic data base consulted during the international search (name of data base and, where practicable, search terms used)		
C. DOCUMENTS CONSIDERED TO BE RELEVANT		
Category*	Citation of document, with indication, where appropriate, of the relevant passages	Relevant to claim No.
X Y A	JP 2000-300554 A (GE Yokogawa Medical Systems, Ltd.), 31 October, 2000 (31.10.00), Full text; all drawings (Family: none)	1, 2, 6, 7, 9, 10 4 3, 5, 8
Y A	JP 5-42157 A (Olympus Optical Co., Ltd.), 23 February, 1993 (23.02.93), Full text; all drawings (Family: none)	4 1-3, 5-10
A	JP 2002-119508 A (Matsushita Electric Industrial Co., Ltd.), 22 April, 2002 (22.04.02), Full text; all drawings (Family: none)	1-10
<input checked="" type="checkbox"/> Further documents are listed in the continuation of Box C. <input type="checkbox"/> See patent family annex.		
* Special categories of cited documents:		
"A" document defining the general state of the art which is not considered to be of particular relevance	"T" later document published after the international filing date or priority date and not in conflict with the application but cited to understand the principle or theory underlying the invention	
"E" earlier document but published on or after the international filing date	"X" document of particular relevance; the claimed invention cannot be considered novel or cannot be considered to involve an inventive step when the document is taken alone	
"L" document which may throw doubts on priority claim(s) or which is cited to establish the publication date of another citation or other special reason (as specified)	"Y" document of particular relevance; the claimed invention cannot be considered to involve an inventive step when the document is combined with one or more other such documents, such combination being obvious to a person skilled in the art	
"O" document referring to an oral disclosure, use, exhibition or other means	"&" document member of the same patent family	
"P" document published prior to the international filing date but later than the priority date claimed		
Date of the actual completion of the international search 30 June, 2003 (30.06.03)	Date of mailing of the international search report 15 July, 2003 (15.07.03)	
Name and mailing address of the ISA/ Japanese Patent Office	Authorized officer	
Facsimile No.	Telephone No.	

Form PCT/ISA/210 (second sheet) (July 1998)

INTERNATIONAL SEARCH REPORT

International application No.

PCT/JP03/04285

C (Continuation). DOCUMENTS CONSIDERED TO BE RELEVANT		
Category*	Citation of document, with indication, where appropriate, of the relevant passages	Relevant to claim No.
A	JP 2002-34976 A (Toshiba Corp.), 05 February, 2002 (05.02.02), Full text; all drawings (Family: none)	1-10
A	JP 2001-95798 A (Matsushita Electric Industrial Co., Ltd.), 10 April, 2001 (10.04.01), Full text; all drawings (Family: none)	1-10
A	JP 2001-8933 A (Matsushita Electric Industrial Co., Ltd.), 16 January, 2001 (16.01.01), Full text; all drawings (Family: none)	1-10

Form PCT/ISA/210 (continuation of second sheet) (July 1998)

INTERNATIONAL SEARCH REPORT

International application No.

PCT/JP03/04285

Box I Observations where certain claims were found unsearchable (Continuation of item 2 of first sheet)

This international search report has not been established in respect of certain claims under Article 17(2)(a) for the following reasons:

1. Claims Nos.:
because they relate to subject matter not required to be searched by this Authority, namely:
2. Claims Nos.:
because they relate to parts of the international application that do not comply with the prescribed requirements to such an extent that no meaningful international search can be carried out, specifically:
3. Claims Nos.:
because they are dependent claims and are not drafted in accordance with the second and third sentences of Rule 6.4(a).

Box II Observations where unity of invention is lacking (Continuation of item 3 of first sheet)

This International Searching Authority found multiple inventions in this international application, as follows:

The technical feature common to all the claims is the one of claim 1. However, the international search has revealed that the technical feature of claim 1 is not novel since it is disclosed in JP 2000-300554 A (GE Yokogawa Medical Systems, Ltd.) 2000.10.31. Therefore the technical feature of claim 1 is not considered as a special technical feature within the meaning of PCT Rule 13. Therefore, there is no feature common to all the inventions of the claims. No technical relationship within the meaning of PCT Rule 13 between the different inventions can be seen.

Consequently, it appears that claims 1-10 do not satisfy the requirement of unity of invention.

1. As all required additional search fees were timely paid by the applicant, this international search report covers all searchable claims.
2. As all searchable claims could be searched without effort justifying an additional fee, this Authority did not invite payment of any additional fee.
3. As only some of the required additional search fees were timely paid by the applicant, this international search report covers only those claims for which fees were paid, specifically claims Nos.:
4. No required additional search fees were timely paid by the applicant. Consequently, this international search report is restricted to the invention first mentioned in the claims; it is covered by claims Nos.:

- Remark on Protest** The additional search fees were accompanied by the applicant's protest.
 No protest accompanied the payment of additional search fees.

专利名称(译)	超声检查		
公开(公告)号	EP1500371A4	公开(公告)日	2011-07-27
申请号	EP2003747204	申请日	2003-04-03
[标]申请(专利权)人(译)	株式会社日立医药		
申请(专利权)人(译)	日立医疗器械股份有限公司		
当前申请(专利权)人(译)	日立医疗器械股份有限公司		
[标]发明人	OKADA KAZUTAKA KANDA HIROSHI OTAKE TSUYOSHI KIMURA TSUYOSHI HAYASHI TATSUYA		
发明人	OKADA, KAZUTAKA KANDA, HIROSHI OTAKE, TSUYOSHI KIMURA, TSUYOSHI HAYASHI, TATSUYA		
IPC分类号	A61B8/00 G01S15/89		
CPC分类号	G01S15/8954 A61B8/00 G01S7/52038 G01S15/8963		
优先权	2002126075 2002-04-26 JP		
其他公开文献	EP1500371A1		
外部链接	Espacenet		

摘要(译)

超声波诊断装置包括超声波探头，用于经由超声波探头向待检查对象发送超声波信号的发送单元，用于处理由超声波探头接收的信号的接收单元，以及用于生成图像的图像生成单元基于由接收单元处理的接收信号，其中发送单元具有以时间间隔在相同方向上以变化频率多次发送超声波信号的功能，该多次发送的超声信号包括第一波形，其中频率增加和频率减小的第二波形，并且接收单元具有定相和添加分别对应于第一波形和第二波形的接收信号的功能，由此在组织谐波成像中，穿透得到改善，同时保持分辨率。