

(19) World Intellectual Property Organization  
International Bureau



(43) International Publication Date  
10 March 2011 (10.03.2011)

(10) International Publication Number  
**WO 2011/027270 A1**

- (51) **International Patent Classification:**  
*A61B 8/00* (2006.01)      *G01S 15/89* (2006.01)
- (21) **International Application Number:**  
PCT/IB2010/053858
- (22) **International Filing Date:**  
27 August 2010 (27.08.2010)
- (25) **Filing Language:** English
- (26) **Publication Language:** English
- (30) **Priority Data:**  
61/239,497    3 September 2009 (03.09.2009)      US
- (71) **Applicant (for all designated States except US):** KONINKLIJKE PHILIPS ELECTRONICS N.V. [NL/NL]; Groenewoudseweg 1, NL-5621 BA Eindhoven (NL).
- (72) **Inventor; and**
- (75) **Inventor/Applicant (for US only):** ROBINSON, Andrew, L. [US/US]; c/o High Tech Campus Building 44, NL-5656 AE Eindhoven (NL).
- (74) **Agents:** VAN VELZEN, Maaïke, M et al.; High Tech Campus 44, NL-5600 AE Eindhoven (NL).
- (81) **Designated States (unless otherwise indicated, for every kind of national protection available):** AE, AG, AL, AM, AO, AT, AU, AZ, BA, BB, BG, BH, BR, BW, BY, BZ,

CA, CH, CL, CN, CO, CR, CU, CZ, DE, DK, DM, DO, DZ, EC, EE, EG, ES, FI, GB, GD, GE, GH, GM, GT, HN, HR, HU, ID, IL, IN, IS, JP, KE, KG, KM, KN, KP, KR, KZ, LA, LC, LK, LR, LS, LT, LU, LY, MA, MD, ME, MG, MK, MN, MW, MX, MY, MZ, NA, NG, NI, NO, NZ, OM, PE, PG, PH, PL, PT, RO, RS, RU, SC, SD, SE, SG, SK, SL, SM, ST, SV, SY, TH, TJ, TM, TN, TR, TT, TZ, UA, UG, US, UZ, VC, VN, ZA, ZM, ZW.

(84) **Designated States (unless otherwise indicated, for every kind of regional protection available):** ARIPO (BW, GH, GM, KE, LR, LS, MW, MZ, NA, SD, SL, SZ, TZ, UG, ZM, ZW), Eurasian (AM, AZ, BY, KG, KZ, MD, RU, TJ, TM), European (AL, AT, BE, BG, CH, CY, CZ, DE, DK, EE, ES, FI, FR, GB, GR, HR, HU, IE, IS, IT, LT, LU, LV, MC, MK, MT, NL, NO, PL, PT, RO, SE, SI, SK, SM, TR), OAPI (BF, BJ, CF, CG, CI, CM, GA, GN, GQ, GW, ML, MR, NE, SN, TD, TG).

**Declarations under Rule 4.17:**

- as to applicant's entitlement to apply for and be granted a patent (Rule 4.17(ii))
- as to the applicant's entitlement to claim the priority of the earlier application (Rule 4.17(iii))

**Published:**

- with international search report (Art. 21(3))

(54) **Title:** ULTRASOUND PROBE WITH LARGE FIELD OF VIEW AND METHOD FOR FABRICATING SUCH ULTRASOUND PROBE

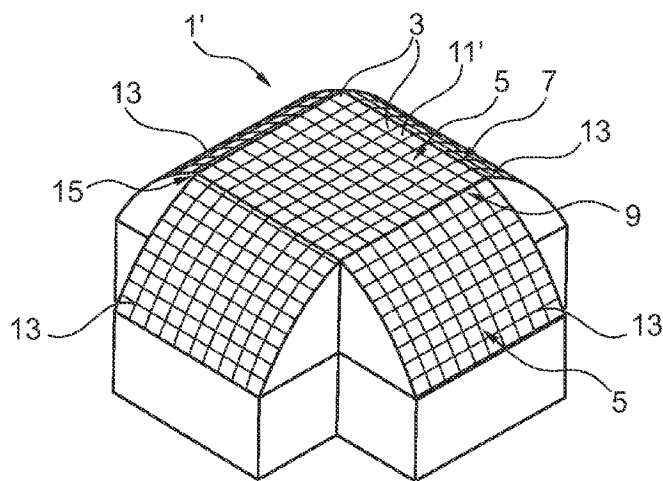

**Fig. 4**

(57) **Abstract:** An ultrasound transducer matrix array for an ultrasound probe having a large field of view both in azimuth and elevation direction is proposed. The ultrasound transducer matrix array (1') comprises a center region (11') and at least three branch regions (13) each comprising a 2-dimensional matrix array (5) of ultrasound transducer elements (3). The center region comprises at least three edges (15) from which the respective branch regions extend. Each branch region (13) is curved around an axis parallel to the edge (15) of the center region (11) from which the respective branch region (13) extends. With an ultrasound probe comprising such ultrasound transducer area with branch regions interconnected by a common, preferably flat center region, an ideal matrix array having a field of view with a spheroidal shape may be approximated.



WO 2011/027270 A1

Ultrasound probe with large field of view and method for fabricating such ultrasound probe

## FIELD OF THE INVENTION

The invention relates to an ultrasound probe which has a large field of view due to a specific geometric arrangement of ultrasound transducer array elements.

Furthermore, the invention relates to a method of fabricating an ultrasound probe.

5

## BACKGROUND OF THE INVENTION

In medical ultrasound applications, ultrasound transducers are generally used for transmission and reception of ultrasonic or acoustic waves during ultrasound imaging.

The region within the patient's body from which an image can be obtained with sufficiently high image quality and sufficiently low levels of artefacts is referred to as the field of view. A transducer's field of view depends on several factors, among them the transducer array element size, the transducer array aperture, and the transducer array geometry.

Many transducers available on the market comprise a 1D array of ultrasound transducer elements. Each element is a separate, nominally-independent transducer that is used to both transmit ultrasound energy into a body of a patient and receive echoes from structures within the body. Medical ultrasound usually operates in the 1-20 MHz frequency range, necessary to provide imaging detail appropriate to the structures with the human body. Lower and higher frequencies may be used for specific applications.

Each element in a 1D array is typically rectangular, with a narrow extent in one direction (commonly referred to as the azimuth direction), a longer extent in an orthogonal direction (commonly referred to as the elevation direction), and a thickness in the direction orthogonal to the other two directions (commonly referred to as range direction). The size of a transducer element, i.e. its width in the azimuth direction and length in the elevation directions, may determine its acceptance angle at a given frequency. This acceptance angle may be the angle at which an element receives enough energy to contribute constructively to an ultrasound signal. As element width increases, the acceptance angle generally decreases. Furthermore, acceptance angle is also a function of frequency; for a given width the acceptance angle generally decreases with increasing frequency.

While a 1D transducer array usually focuses ultrasonic energy in the elevation direction to a fixed focus region by placing a cylindrical acoustic lens on a face of the transducer array, a region of interest may be scanned in the azimuth direction typically in one of two basic formats: “sector scanning” or “linear scanning”.

5                 With sector scanning, the field of view may be a section of a circle with its center in the center of the face of the array. With the sector scan format, the ultrasound beams may be steered radially from the center of the array, and an angle of each successive beam may be different. The delays applied to transmit and receive signals may determine both the steering angle and the focus. Transducers that use a sector scan format are commonly  
10 referred to as sector arrays or phased arrays. Such transducers may have elements with widths in the order of  $\lambda/2$ , where  $\lambda$  may be defined as the acoustic wavelength at the frequency in the center of the band in which the transducer operates. A typical phased array provides a field of view with a sector width of  $90^\circ$ .

                  Alternatively, with a linear scan format, each beam may be perpendicular to  
15 the face of the array, and the position of the beam along the array face may be translated laterally to sweep out a rectangular field of view. In this case, the beams may not be steered but are only focused. The delays applied to the transmit and receive signals determine the location of the focus. Transducers that use the linear scan format are commonly referred to as linear arrays, and may have elements with widths in the order of  $\lambda$ . The width of the  
20 rectangular field of view is typically the same as the azimuthal length of the transducer.

                  It may also be possible to build arrays that are curved, and which provide a curved field of view. These transducers typically operate with a linear scan format, i.e. with ultrasound beams that are projected perpendicular to the face of the array. The curvature in the field of view may be provided by translating the ultrasound beams along a curved surface  
25 rather than by steering them. Curved transducer arrays operating in a linear scan mode are sometimes referred to as “curved linear arrays” (CLA). Curved linear arrays may provide a larger field of view than flat linear arrays, while avoiding the image quality compromises involved with steering acoustic beams. It may also be possible to have a curved field of view that is larger than the  $90^\circ$  sector typically available from a sector array.

30                 It should be noted that the ultrasound beams used with both flat and curved linear arrays can be steered. However, because linear arrays have wider elements in azimuth than do phased arrays, the ultrasound beam cannot be steered as far as with phased arrays. Thus a flat linear array may have a trapezoidal field of view, using steering to image the angled edges of the field of view.

“Beam forming” may refer to a process of combining signals transmitted and received by the array elements into a sum that represents the ultrasound signal received from a single point in the field of view. In general, for a 1D transducer each transducer element is connected to a separate “channel” in the ultrasound system, wherein a channel may comprise a transmitter, a receiver and delay circuits used to control the timing of transmitted and received signals. The time may be controlled to focus ultrasound energy on transmit and to synthesize a focus for the received signals. A delay applied to each channel may be such that the acoustic signal transmitted by each of the array elements is received at a target at the same time. The delay may be the difference in ultrasound propagation time, determined for example by the speed of sound and the distance of each element from the target.

Because of a combination of the array geometry, steering and/or focus in azimuth provided by the system beam former, and focus in elevation provided by the fixed lens, 1D arrays typically image a section of a “plane”, that is, there is no steering or controlled variable focus of acoustic beams in the elevation direction.

Whereas 1D transducer arrays have elements of ultrasound transducers that span the entire elevation dimension of the array, 2D or matrix arrays may be also divided into elements in the elevation direction. When each element is provided with its own ultrasound beam forming electronics so that the delay applied to its signal can be different from that of its neighbouring element, a possibility of steering, translating, and focusing in the elevation direction as well as in azimuth direction may be obtained. The ability to steer and/or translate the ultrasound beam in the elevation direction may enable imaging a volume of space, rather than just within a plane.

The beam forming electronics provided to each ultrasound transducer element in a matrix array may also be referred to as “microbeamformer”. The beam forming function of the entire ultrasound system may be partitioned so that part of it takes place in the microbeamformer and the rest in the over-all controlling system. For example, the transducer elements may comprise a piezoelectric layer arrangement which is contacted by electrodes such that by applying a suitable voltage, the transducer elements can be activated to emit ultrasonic vibrations. The voltage may be applied and controlled using a control circuit associated to the piezoelectric layer arrangement of each of the ultrasound transducer elements. Accordingly, each of the ultrasound transducer elements may be provided with its own “microchannel” comprising a transmitter, receiver and delay circuitry. This may allow signals from contiguous groups of elements to be combined together to drive a single system

channel; the microbeam former must provide only a relatively small amount of delay to account for the difference between it and the other elements in its group.

As with 1D arrays, the field of view available from a 2-dimensional matrix array may depend on the array geometry and the scan formats that can be supported by its elements. If the array elements are sufficiently small in both azimuth and elevation direction, the acoustic beam may be steered in both directions. Larger array elements may allow less steering. Array elements need not be square; for example, a matrix array with  $\lambda$  elements in azimuth and  $\lambda/2$  elements in elevation may be used and may be operated with a linear scan format in azimuth and a sector scan format in elevation.

However, matrix arrays of ultrasound transducers may have limitations concerning their field of view. Field of view limitations may be addressed to a certain extent by increasing the size of an aperture to bring the desired field of view within the steering range of the matrix array. However, there may be limits to the extent that this can be exploited, especially for intracavity ultrasound transducers where increasing transducer size is not an option. It may also be possible to increase steering by decreasing the size of the array elements. However, with matrix arrays this may also decrease the amount of area available for microchannel electronics that must fit in a space associated with each of the transducer elements such that there may be limitations on how small the transducer elements may be made.

In order to provide a larger field of view than is possible with steering a flat (sector) array, curved matrix arrays may be used. In such curved matrix arrays, the ultrasound transducer elements may be arranged on a curved surface. An additional advantage of a curved matrix array may be that a larger field of view may be achieved with fewer, larger transducer elements than the smaller phased array elements required for large steering angles.

However, it has been observed that also curved matrix arrays of ultrasound transducer elements may have limitations with respect to the field of view as well with respect to image quality.

#### SUMMARY OF THE INVENTION

Accordingly, there may be a need for an improved ultrasound transducer matrix array for an ultrasound probe which may overcome some of the field of view and image quality limitations of prior curved matrix arrays, particularly for the case where increasing aperture size or reducing element size for more steering to achieve a larger field of view may not be an option.

It has been found that an ideal curved matrix transducer array may have a spheroidal shape with a surface curved in two directions. However, current array fabrication techniques may not allow for curvature over such a compound surface curve. While it may be easy to fabricate a curved matrix array which may be curved/bent in one direction, i.e. around one curving axis, thereby forming a cylindrical surface, it may be difficult or impossible to prepare an ultrasound transducer having a sufficiently large over-all area and being curved in two directions thereby forming a complex curved surface.

An idea underlying the present invention is to approximate a complex surface of an ultrasound transducer, for example a spheroidal surface, by an approximation using different regions, each comprising a matrix array of ultrasound transducer elements, and combining an over-all ultrasound transducer area from these regions. Therein, at least some of the regions may be curved around specific curving axes, whereas other regions may not be curved, i.e. may be flat, or may only be slightly curved. Particularly, it may be advantageous to provide a flat or only slightly curved region interconnecting adjacent substantially curved regions.

According to a first aspect of the present invention, an ultrasound transducer matrix array for an ultrasound probe is proposed with an over-all ultrasound transducer area comprising a center region and at least three branch regions. The center region and the branch regions each comprise a matrix array of ultrasound transducer elements. Therein, the center region has at least three edges and each of the branch regions extends from one of these edges of the center region. Furthermore, each branch region is curved or bent around an axis parallel to the respective edge of the center region from which the branch region extends.

Accordingly, the over-all ultrasound transducer area may be a combination of the center region and the plurality of branch regions. The over-all ultrasound transducer area may cover a continuous surface with the branch regions directly abutting the center region. In other words, the branch regions may be interconnected via the interposed center region in between.

Each of the matrix arrays included in the center region and the branch regions comprises a plurality of ultrasound transducer elements which are distributed over a 2D area of the respective region. For example, ultrasound transducer elements may be arranged in rows and columns wherein each region comprises a plurality of rows and a plurality of columns.

For example, the over-all ultrasound transducer area comprising the center region and the branch regions may form a cross-shape. Therein, the center may be

rectangular with a matrix of A rows and B columns of ultrasound transducer elements. Two branch regions e.g. abutting to the center region at opposing edges may comprise a matrix of A rows and C columns of ultrasound transducer elements whereas two further branch regions abutting to the remaining opposing edges of the center region may comprise a matrix of D rows and B columns of ultrasound transducer elements. In other words, the over-all cross-shaped ultrasound transducer area may comprise four branch regions and an interposed center region wherein the dimensions of the center regions are correlated to the respective widths of the abutting branch regions. Various ratios of A, B, C and D are possible. For example, the center region may be rectangular ( $A \neq B$ ) or square ( $A = B$ ). Furthermore, the branch regions may have identical dimensions ( $C = D$ ) or may be different ( $C \neq D$ ) in their lengths.

Advantageously, the center region is flat. While the branch regions each may be curved around an axis parallel to an abutting edge of the center region and may therefore represent cylindrical surfaces oriented in different directions, it may be preferable to provide the center region without any curvature thereby possibly eliminating the need of a complex compound curvature for the center region interconnecting abutting branch regions. Each of the branch regions may be curved to a same side with respect to a plane including the flat center region.

It may be preferable to arrange at least a portion of the matrix array of transducer elements of the center region and/or of the branch regions with a phased array pitch. Such phased array pitch arrangement may allow for operating the ultrasound transducer in a sector scanning mode in which emitted ultrasound beams may be steered. With such steering, for example, deviations of the center region and/or the branch regions from a cylindrical or spheroidal ideal may be compensated by suitable beam forming using a combination of translation and steering to accommodate the non-cylindrical and/or non-spheroidal geometry.

For example, the matrix array of transducer elements in the center region may be arranged with a phased array pitch in both orthogonal main directions whereas the matrix array of transducer elements of each of the branch regions may be arranged with a phased array pitch only in the main direction parallel to the edge from which the respective branch region extends. In other words, the transducer elements in the center region may have dimensions in both, length and width, of  $\lambda/2$ . The transducer elements in the branch regions may have a dimension of  $\lambda/2$  in the width direction, i.e. the direction parallel to the edge of the abutting center region, and another dimension such as for example a  $\lambda$  dimension in a length direction perpendicular to the edge of the abutting center region.

While in such an approach, different designs for the transducer element dimensions may be necessary for the center region and the branch regions, the total number of transducer elements and respective control elements controlling each of the transducer elements may be minimized.

5            Advantageously, the ultrasound elements are arranged on a bendable substrate and each of the ultrasound elements may be provided with an associated control circuit acting as a microbeamformer, which control circuit is preferably integrated in a common substrate. For example, the bendable substrate may be a thin silicon substrate having a thickness which allows for sufficiently bending the substrate together with the ultrasound transducer elements  
10            created therewith. Such thickness may be e.g. less than 100  $\mu\text{m}$ , preferably less than 50  $\mu\text{m}$ . In such silicon substrate, the circuitry for controlling a signal to the transducer elements may be integrated.

                  As noted above, the ultrasound transducer elements may comprise a layer arrangement which may be activated to ultrasonic vibrations. Such layer arrangement may  
15            comprise for example one or more piezoelectric layers with respective electrodes. The ultrasound transducer elements furthermore may be provided with a control circuit included in a substrate. Advantageously, the layer arrangement is mechanically attached to the substrate by flip-chip-technology. The application of such flip-chip-technology may provide for connections from each of the array vibration elements to its corresponding circuitry. Such  
20            an approach is also referred to as a “flip-chip microbeamformer”, where each element’s microchannel may be small enough to fit in a space limited by the element’s azimuth and elevation dimensions. The microbeamformer may be built in an application specific integrated circuit (ASIC) that may be essentially the same size as the array, optionally plus some extra space around the perimeter for overhead functions. Accordingly, each  
25            microchannel may sit behind its element, with electrical contact made through a conductive post between them.

                  Furthermore, advantageously, the over-all ultrasound transducer area may be composed of a plurality of tiles. For example, one ultrasound transducer matrix array tile may  
30            comprise the center region and two of the branch regions arranged at opposite edges of the center region at least one further ultrasound transducer matrix array tile may comprise one or more further branch regions. Alternatively, the over-all ultrasound transducer area may be composed of at least three, preferably four, identical ultrasound transducer matrix array tiles. Each tile may comprise an ASIC comprising specific circuitry for controlling the microbeamformers. Onto the ASIC, an ultrasound transmitting layer may be disposed and

electrically connected wherein the respective ultrasound transducer elements may be created by dicing the ultrasound transmitting layer to generate respective elements. Details and possible embodiments using ultrasound transducer matrix array tiles will be described further below with respect to specific embodiments of the present invention.

5           According to a further aspect of the present invention, a method of fabricating an ultrasound probe is proposed, wherein the method comprises providing an over-all ultrasound transducer area comprising center region and at least three branch regions each comprising a matrix array of ultrasound transducer elements wherein each branch region extends from one of at least three edges of the center region. The method further comprises  
10   arranging each branch region in a curved configuration around an axis parallel to the edge of the center region from which the respective branch region extends.

          The over-all ultrasound transducer area may be composed from a plurality of tiles. Each tile may comprise an ASIC in which a control circuitry may be prepared with standard semiconductor technologies. On a surface of the ASIC, a layer may be deposited or  
15   bonded which may be made from a material which can be activated for ultrasound vibration. This layer may then be diced to prepare a multiplicity of transducer elements arranged in matrix arrays wherein each elements may be controlled by its associated ASIC. In the branch regions, at least some of the dicing cuts may be arranged parallel to the edge of the center region from which the respective branch region extends. Thereby, assuming a flexible  
20   substrate for the ASICs, the branch regions may be bent into a shape curved around an axis parallel to the respective edges.

          It has to be noted that aspects and embodiments of the present invention are described herein with reference to different subject-matters. In particular, some embodiments are described with respect to the ultrasound probe whereas other embodiments are described  
25   with respect to the method of fabricating the ultrasound probe. However, a person skilled in the art will gather from the above and the following description that, unless other notified, in addition to any combination of features belonging to one type of subject-matter also any combination between features relating to different subject-matters, in particular between features of the apparatus type claims and features of the method type claims, is considered to  
30   be disclosed with this application.

## BRIEF DESCRIPTION OF THE DRAWINGS

Features and advantages of the present invention will be further described with respect to specific embodiments as shown in the accompanying figures but to which the invention shall not be limited.

5 Fig. 1 shows a conventional curved matrix array of ultrasound transducer elements.

Fig. 2a,b,c,d show representations of a field of view of the matrix array of Fig. 1 in perspective view, top view, azimuth view and elevation view, respectively.

10 Fig. 3 shows a perspective view of a matrix array arrangement for an ultrasound probe according to an embodiment of the present invention.

Fig. 4 shows a perspective view of a matrix array arrangement for an ultrasound probe with a flat center region according to another embodiment of the present invention.

15 Fig. 5 shows a cross-section of a matrix array arrangement for the ultrasound probe of Fig. 4.

Figs. 6a,b,c show representations of a field of view of an ultrasound probe with a linear array pitch according to an embodiment of the present invention in perspective view, top view and azimuth/elevation view, respectively.

20 Figs. 7a,b,c show representations of a field of view of an ultrasound probe with a phased array pitch according to an embodiment of the present invention in perspective view, top view and azimuth/elevation view, respectively.

Fig. 8 shows a cross sectional view of a matrix array of ultrasound transducers for use in an embodiment of the present invention.

25 Fig. 9 shows an ultrasound probe arrangement composed of three tiles according to an embodiment of the present invention.

Fig. 10 shows an ultrasound probe arrangement composed of four tiles according to an embodiment of the present invention.

Fig. 11 shows an ultrasound probe arrangement comprising four identical tiles according to an embodiment of the present invention.

30 Fig 12 shows a top view of a matrix array arrangement for an ultrasound probe arrangement according to an embodiment of the present invention prior to curving.

Fig. 13 shows a top view of a matrix array arrangement for an ultrasound probe with a matrix array arrangement optimized for minimizing the number of transducer elements according to an embodiment of the present invention.

Features shown in the figures are only schematical and not to scale. Same or similar features are labeled with same or similar reference signs. Furthermore, lines on surfaces shown in the figures do not necessarily indicate any actual connections or even segments of transducer elements but may refer to surface contours intended to help make the 3D surface more apparent in a 2D drawing.

#### DETAILED DESCRIPTION OF THE INVENTION

Fig. 1 shows a conventional matrix array 100 of ultrasound transducer elements 103 arranged along a surface which is bent around an axis 105. The matrix array comprises a plurality of columns 107 and rows 109 of ultrasound transducer elements 103 arranged on a two-dimensional surface. The exemplary curved matrix array has a radius of curvature ROC of 11.5 mm, a field of view angle  $\alpha$  of  $130^\circ$  in azimuth, and an aperture width  $w$  in elevation of 10 mm. The ultrasound transducer elements 103 are arranged with a phased-array pitch in elevation direction to support  $90^\circ$  steering.

Figs. 2a,b,c and d show a perspective view, a top view, an azimuth view and an elevation view of the field of view obtainable with the curved matrix array shown in Fig. 1.

Fig. 3 shows a perspective view of an ultrasound transducer matrix array 1 for an ultrasound probe, the matrix array 1 having a curved cross-shaped form and comprising a center region 11 interconnecting four branch regions 13. Each of the regions 11, 13 comprises a matrix array 5 of ultrasound transducers 3. The branch regions 13 extend from respective edges 15 of the center region 11. Each of the branch regions 13 is curved around an axis parallel to the respective edge 15 from which it extends.

In the embodiment shown in Fig. 3, the center region 11 may have a complex curved surface which is curved in two directions. However, it may be difficult to fabricate a matrix array of transducer elements with such complex curvature. This may be due for example to the fact that the material from which the transducer elements are made may be bendable around one axis thereby being easily curved in a cylindrical surface but may not be deformed in a complex curved shape due to a lacking mechanical flexibility/elasticity.

Accordingly, it may be advantageous to provide an ultrasound transducer matrix array 1' with a flat center region 11' as shown in Fig. 4. The flat center region 11' may have a rectangular shape with four edges 15 from which curved branch regions 13 extend. The matrix array 5 of the flat center region 11' may comprise A columns 7 and B rows 9 of ultrasound transducer elements 3. In the embodiment of Fig. 4, the center region

11' is square ( $A = B$ ). The matrix arrays 5 of the branch regions 13 directly abut to one of the edges 15 of the center region 11' and each have the same width as the dimension of the edge 15 of the center region 11' from which they extend. Accordingly, the branch regions 13 may have A or B transducer elements 3 in a width direction. However, their length may be different. In principle, each of the branch regions may have a different length and/or a different radius of curvature; however, it may be advantageous to provide each of the branch regions with a same length and a same radius of curvature thereby achieving a symmetric arrangement.

Fig. 5 shows a cross-section of the ultrasound transducer matrix array 1' shown in Fig. 4. Two curved branch regions 13 extend from the flat center region 11' at edges 15.

The field of view of ultrasound probe with a cross-shaped curved ultrasound transducer matrix array as shown in Fig. 4 may not be a complete spheroid; there may be gaps in the "corners" where neither of the orthogonal apertures can provide adequate image quality.

The actual field of view of such cross-shaped ultrasound transducer may depend on both the curved surface provided by the basic geometry of the matrix arrays of ultrasound transducer elements, plus the available steering which may be dependent on the element pitch.

If the entire matrix array is diced on a linear array pitch in both azimuth and elevation, steering is usually limited to about  $45^\circ$ . Figs. 6a,b,c illustrate the resulting field of view in a perspective view, top view and azimuth/elevation view, respectively. This approach may provide coverage of about half of an ideal spheroidal field of view, with gaps in the "corners" which may be beyond the combined translation and steering of the composite array.

Such a transducer may also provide improved image quality in the transverse plane through the center of the array, over a larger field of view, than would be possible with a single curved matrix array as for example shown in Fig. 1. In addition to the field of view improvements as noted above the image quality in the transverse plane may improve as well by providing for curved linear array operation in that direction, instead of relying only on steering. The curved matrix array shown in Fig. 1 may achieve a  $90^\circ$  field of view in elevation as shown in Fig. 2d only if it has phased-array pitch in elevation, whereas the cross-shaped array shown in Figs. 3 or 4 has a  $130^\circ$  field of view in elevation even if diced at a larger linear-array pitch. The improved image quality results from the larger available aperture in the elevation direction.

It may be noted that such cross-shaped array as shown in Figs. 3 or 4 may have fewer ultrasound transducer elements and respective microchannels than a conventional curved matrix array as shown in Fig. 1. For example, let the conventional curved matrix array shown in Fig. 1 comprise 128 columns and 64 rows; therefore, it comprises  $128 \times 32 =$   
5  $8192$  individual transducer elements and microchannels. To obtain a  $90^\circ$  field of view, the B rows must be diced on a phased array pitch. Let the cross-shaped array shown in Figs. 3 or 4 be symmetrical, where the dimensions of either major axis be the same as the array in Fig. 1. Furthermore, let the array be diced on linear array pitch in both directions; there will be 128 columns in the azimuth direction and 32 rows in the elevation direction for each of the  
10 crossed arrays. The total number of elements in the array will then be  $2 \times (128 \times 32) - 32 \times 32 = 7168$  individual array elements. Although the crossed array may have more surface area, it has fewer array elements because it is diced at linear array pitch in both directions.

Figs. 7a,b,c show a perspective view, a top view and an azimuth/elevation view, respectively, of a field of view for an ultrasound probe with an ultrasound transducer matrix array according to an embodiment of the present invention in which the entire array is  
15 diced to provide phased array pitch in elevation. This may provide about  $90^\circ$  of steering. In this case, the increased steering may provide for much more coverage of an ideal spheroidal field of view. As will be further described below with respect to Fig. 9, it may not be necessary to dice the entire array at phased array pitch.

In the embodiment shown in Fig. 7, matrix arrays having a  $130^\circ$  azimuth field of view as discussed further above with respect to the conventional curved matrix array show in Fig. 1 have been used for the various regions of the ultrasound probe. The result may be an improvement in field of view of somewhat less than 50% over the conventional single curved matrix array of Fig. 1 with  $90^\circ$  steering. If the azimuth field of view is increased above  $130^\circ$ ,  
25 then the field of view improvement may increase beyond what is illustrated in Fig. 7.

In addition to the field of view improvements as noted above the image quality in the transverse plane may improve as well by providing for curved linear array operation in that direction, instead of relying only on steering.

Fig. 8 shows a cross sectional view of a matrix array 5 of ultrasound  
30 transducers 3. In a common bendable substrate 31, a plurality control circuits 37 have been integrated. Each of the control circuits 37 is connected via connections 33 to an associated layer arrangement 35 which may be activated to ultrasonic vibrations. The layer arrangement may comprise a piezoelectric layer together with one or more additional layers for improving acoustic impedance match, thereby forming an acoustic stack. The connections 33 have been

established via flip-chip technology. The plurality of vibration layer arrangements 35 may be produced by first connecting an over-all layer arrangement to the substrate 31 and subsequently dicing it thereby separating the plurality of vibration layers arrangement 35.

As shown in Figs. 9 to 11, an over-all ultrasound transducer area of an  
5 ultrasound probe according to embodiments of the present invention may be composed of a plurality of ultrasound transducer matrix array tiles 21, 23, 25. The over-all ultrasound transducer area may comprise at least three, but probably four or more, ASICs. In the embodiments shown in Figs. 9 to 11, a symmetrical over-all ultrasound transducer area is shown, but symmetry is not a requirement.

10 Figs. 9 and 10 illustrate two embodiments in which two different ASIC designs A, B are used. The two designs may be most likely very similar and the system I/O 27 may be on the outer edges of the ASICs. The ASICs may be tiled prior to bonding to the acoustic stack. Alternatively, pre-bonded ASIC/acoustic stack sub-assemblies may be tiled. The pre-bonded sub-assemblies may be diced prior to tiling if either

- 15 (i) the tiling alignment is good enough, or  
(ii) there is a calibration procedure for dealing with any misregistrations.

If not, then the over-all transducer area may be diced after tiling as described below. The tiling should be done on a substrate that either is or may be made flexible for later curving.

20 If the ASICs are tiled before bonding to the acoustic stack, then there may be two basic choices for probe configuration. The tiled ASIC sub-assembly may be bonded to a single large acoustic stack, but this might result in a significant amount of waste from unused corners (4/9 of the over-all area for a design with square symmetry). If the process allows use of multiple probe sub-assemblies, then the probe may comprise either three or four pieces, in  
25 the same configuration as the ASIC as illustrated in Figs. 9 and 10.

It is also possible to use the same approach with a single ASIC design, as shown in Fig. 11. In this case, the two orthogonal apertures may not be the same.

At this point, the ultrasound unit including the over-all transducer area may be ready for dicing, assuming that the ASIC/probe sub-assemblies are not already diced when  
30 tiled. When diced after tiling, the array elements may be properly registered with respect to each other, although the underlying ASICs may be slightly misaligned.

Fig. 12 shows an array geometry after dicing. The unit may then be ready for curving. The substrate may be made sufficiently bendable by using a bendable material. Alternatively, a rigid material may be made bendable by back-dicing. The tools and

techniques for getting the suitable radius of curvature may be similar to those used for conventional one-dimensional transducer arrays. For one-dimensional transducer arrays, one approach may be to place the array face down into a curved tool that provides a specified radius of curvature, pushed into contact with the face of the tool, and bonded to a mechanical support structure behind the ASIC/array sub-assembly. Another approach may be to bond the array face up over a mechanical support structure. Either of these methods may be used for the conventional curved matrix transducer array shown in Fig. 1. Similar techniques may be used for the cross-shaped matrix arrays, except that the tool and mechanical support may be more complex because there may be a flat center region in the middle and there may be two sets of curved branch regions extending therefrom.

After curving, array manufacture may be completed using techniques similar to those used on conventional matrix arrays for ultrasound transducer probes.

As noted above, it may not be necessary to dice the entire array at phased array pitch to achieve the field of view illustrated in Fig. 7. Fig. 13 illustrates a dicing pattern that provides for 90° steering in the elevation direction for each orthogonal sub-set of the over-all array. While dicing in each direction, the pitch may be halved the center region. This may result in elements that are  $\lambda$  in azimuth and  $\lambda/2$  in elevation in the branch regions 13, and  $\lambda/2 \times \lambda/2$  in the flat center region 11. This approach may need different microchannel designs for each of the matrix arrays forming the center region 11 and the branch regions 13, but it may minimize the total number of microchannels.

In order to accommodate the dicing approach of Fig. 13 to the specific tiling arrangement of Fig. 11, it may be necessary to incorporate sufficient flexibility for some microchannel locations on the chip of an ASIC design to deal with either  $\lambda \times \lambda/2$  or  $\lambda/2 \times \lambda/2$  elements.

It should be noted that the terms such as “comprising” do not exclude other elements or steps and that the indefinite article “a” or “an” does not exclude a plurality of elements. Also elements described in association with different embodiments may be combined. It should also be noted that reference signs in the claims shall not be construed as limiting the scope of the claims.

## CLAIMS:

1. An ultrasound transducer matrix array (1) for an ultrasound probe, comprising an over-all ultrasound transducer area comprising:

a center region (11) comprising a matrix array (5) of ultrasound transducer elements (3), wherein the center region (11) has at least three edges (15), and

5 at least three branch regions (13) each comprising a matrix array (5) of ultrasound transducer elements (3), wherein each branch region (13) extends from one of the edges (15) of the center region (11) and wherein each branch region (13) is curved around an axis parallel to the edge (15) of the center region (11) from which the respective branch region (13) extends.

10

2. The ultrasound transducer matrix array of claim 1, wherein the center region (11') is flat.

3. The ultrasound transducer matrix array of claim 1 or 2, wherein the center region (11) and the branch regions (13) together form a cross shape comprising a rectangular center region (11) with a matrix of A rows and B columns of ultrasound transducer elements (3) and two branch regions (13) each with a matrix of A rows and C columns of ultrasound transducer elements (3) and two branch regions (13) each with a matrix of D rows and B columns of ultrasound transducer elements (3).

15  
20

4. The ultrasound transducer matrix array of one of claims 1 to 3, wherein at least a portion of the matrix array of transducer elements (3) of the center region (11) and/or of the branch regions (13) is arranged with a phased array pitch.

25 5. The ultrasound transducer matrix array of one of claims 1 to 4, wherein the matrix array of transducer elements (3) of the center region (11) is arranged with a phased array pitch in both main directions and wherein the matrix array of transducer elements of each of the branch regions (13) is arranged with a phased array pitch only in the main directions parallel to the edge (15) from which the respective branch region (13) extends.

6. The ultrasound transducer matrix array of one of claims 1 to 5, wherein ultrasound transducer elements (3) is provided with a bendable substrate (31).

5 7. The ultrasound transducer matrix array of one of claims 1 to 6, wherein each of the ultrasound transducer elements (3) has an associated control circuit (37).

8. The ultrasound transducer matrix array of claim 7, wherein associated control circuits (37) are integrated in a common substrate (31).

10

9. The ultrasound transducer matrix array of claim 8, wherein each of the ultrasound transducer elements (3) comprise a layer arrangement (35) which may be activated to ultrasonic vibrations and is provided with a control circuit (37) included in a substrate (31) wherein the layer arrangement (35) is mechanically attached to the substrate (31) by flip-chip-technology.

15

10. The ultrasound transducer matrix array of one of claims 1 to 9, wherein the over-all ultrasound transducer area is composed of

20 one ultrasound transducer matrix array tile (21) comprising the center region (11) and two of the branch regions (13) arranged at opposite edges of the center region (11), and

at least one ultrasound transducer matrix array tile (23) comprising a further branch region (13).

25 11. The ultrasound transducer matrix array of one of claims 1 to 9, wherein the over-all ultrasound transducer area is composed of at least three identical ultrasound transducer matrix array tiles (25).

30 12. A method of fabricating an ultrasound transducer matrix array for an ultrasound probe (1), comprising:

- providing an over-all ultrasound transducer area comprising

a center region (11) comprising a matrix array (5) of ultrasound transducer elements (3), wherein the center region (11) has at least three edges (15), and

at least three branch regions (13) each comprising a matrix array (5) of

ultrasound transducer elements (3), wherein each branch region (13) extends from one of the edges (15) of the center region (11);

- arranging each branch region (13) in a curved configuration around an axis parallel to the edge (15) of the center region (11) from which the respective branch region (13) extends.

5

13. The method of claim 12, wherein the center region is arranged in a flat configuration.

14. The method of claim 12 or 13, wherein each of the ultrasound transducer  
10 elements (3) comprise a layer arrangement (35) which may be activated to ultrasonic vibrations and is provided with a control circuit (37) included in a substrate (31), wherein the layer arrangement (35) is is mechanically attached to the substrate (31) by flip-chip-technology.

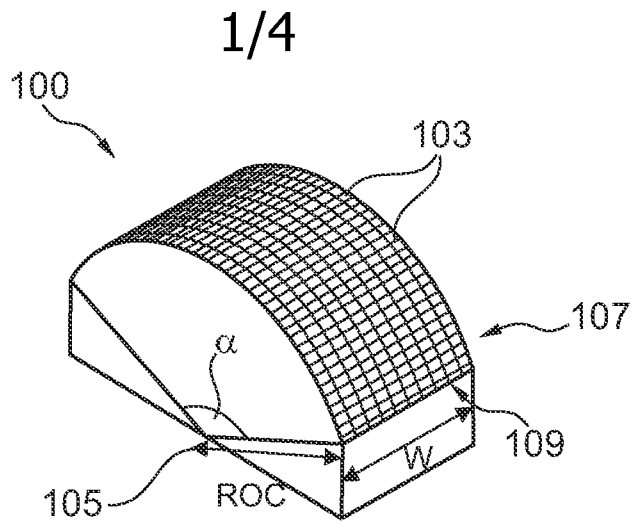

Fig. 1

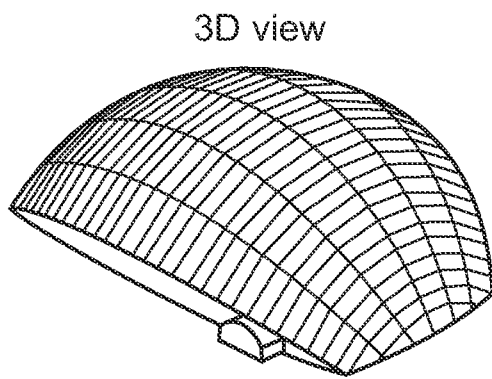

Fig. 2a

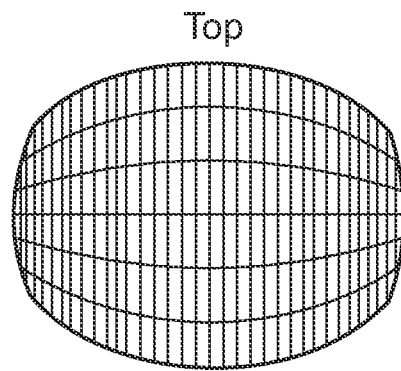

Fig. 2b

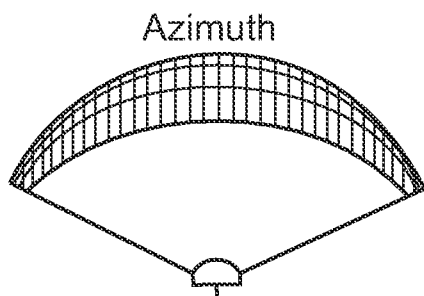

Fig. 2c

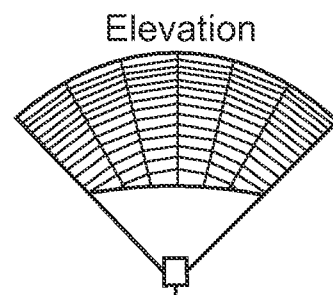

Fig. 2d

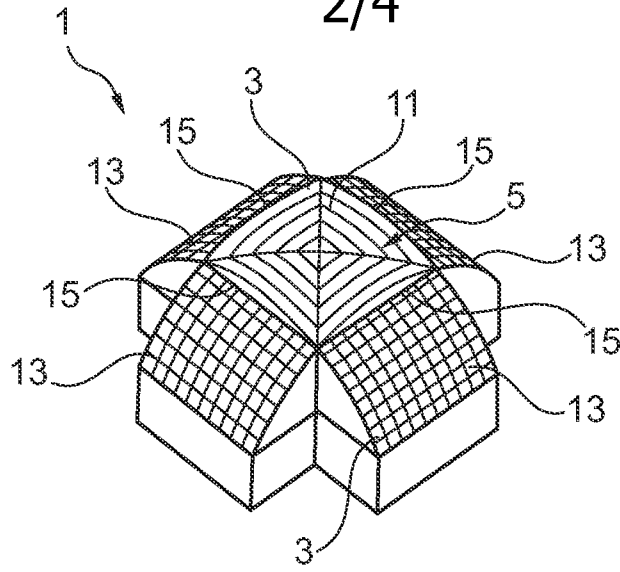

Fig. 3

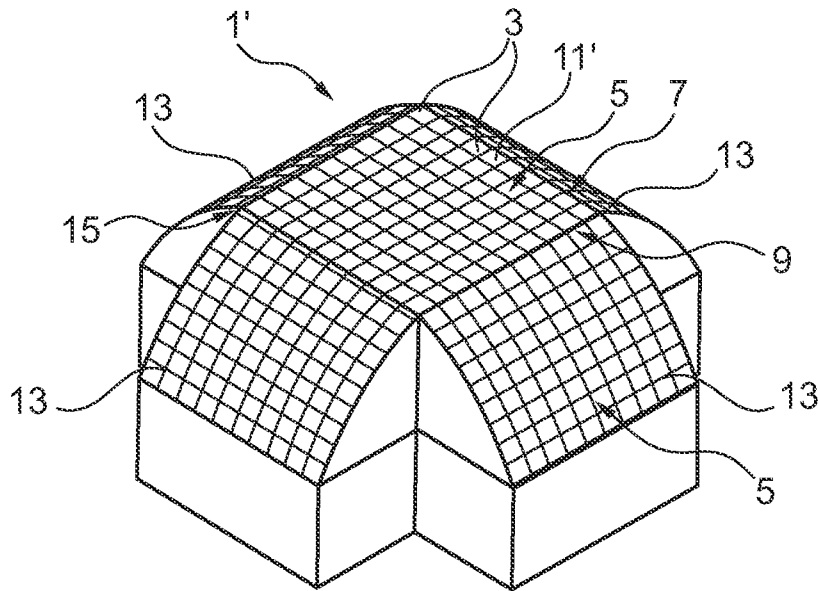

Fig. 4

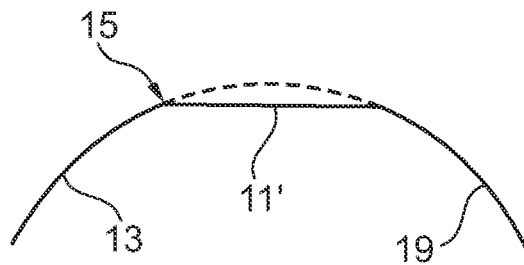

Fig. 5

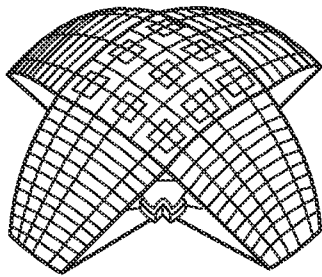

Fig. 6a

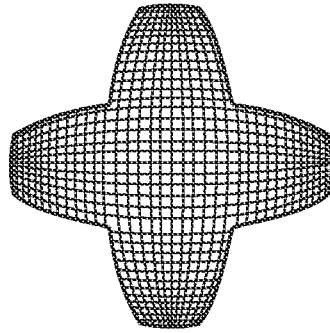

Fig. 6b

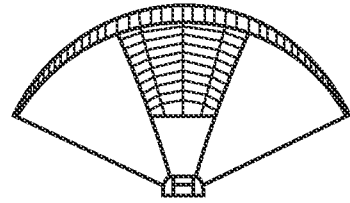

Fig. 6c

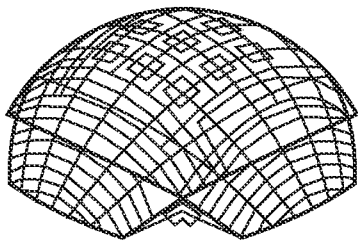

Fig. 7a

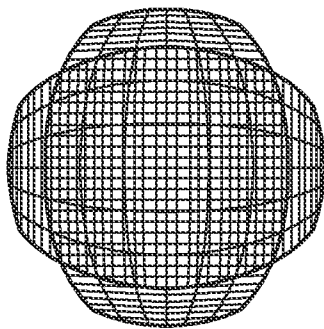

Fig. 7b

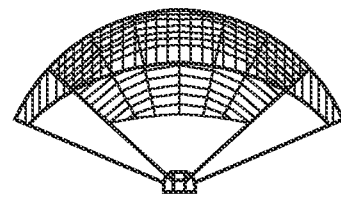

Fig. 7c

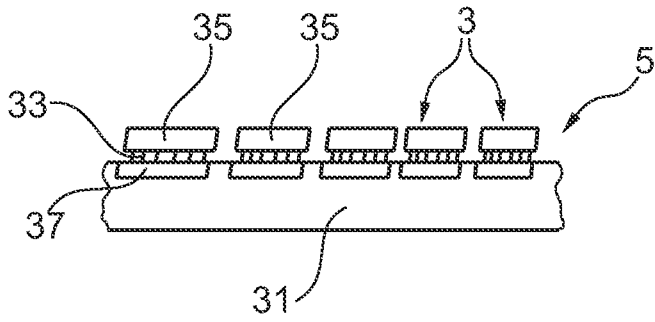

Fig. 8

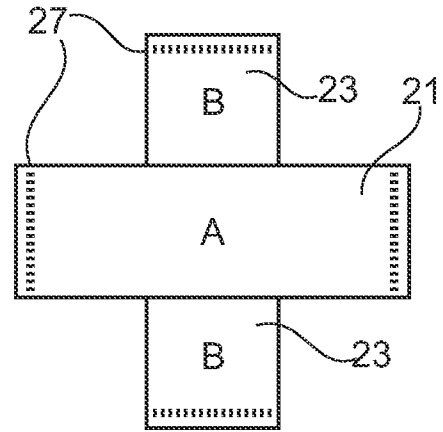

Fig. 9

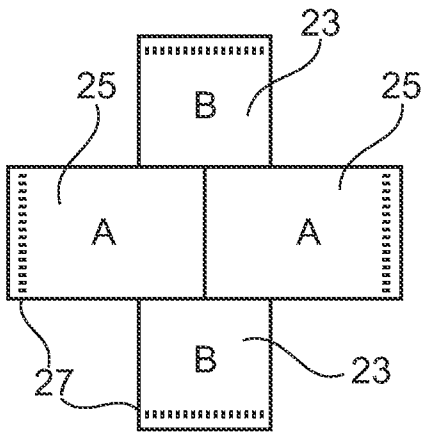

Fig. 10

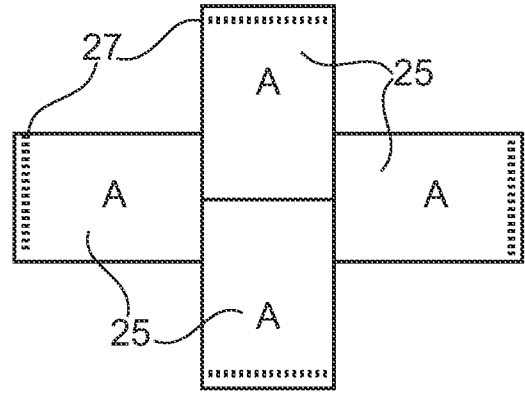

Fig. 11

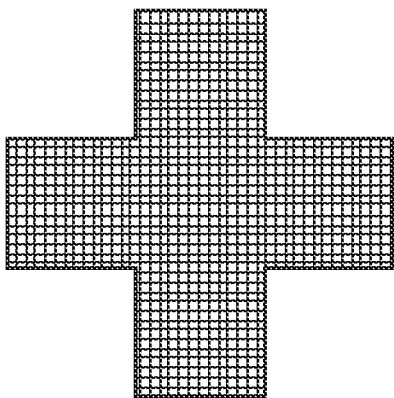

Fig. 12

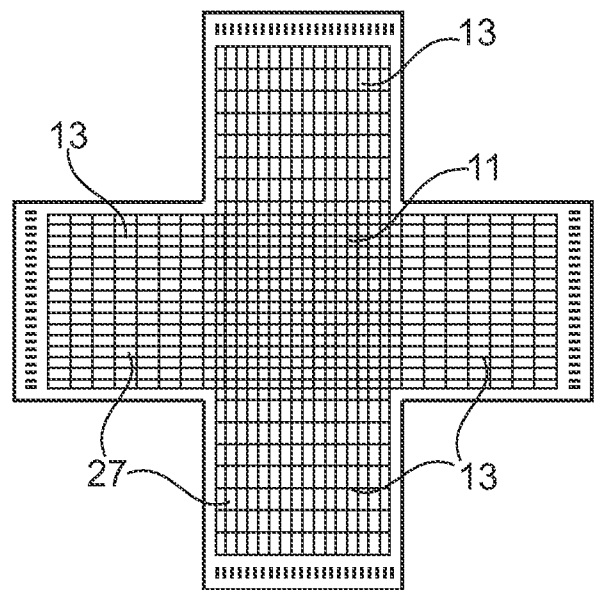

Fig. 13

## INTERNATIONAL SEARCH REPORT

International application No

PCT/IB2010/053858

## A. CLASSIFICATION OF SUBJECT MATTER

INV. A61B8/00 G01S15/89  
ADD.

According to International Patent Classification (IPC) or to both national classification and IPC

## B. FIELDS SEARCHED

Minimum documentation searched (classification system followed by classification symbols)

A61B G01S

Documentation searched other than minimum documentation to the extent that such documents are included in the fields searched

Electronic data base consulted during the international search (name of data base and, where practical, search terms used)

EPO-Internal

## C. DOCUMENTS CONSIDERED TO BE RELEVANT

Category*	Citation of document, with indication, where appropriate, of the relevant passages	Relevant to claim No.
X	US 2004/168517 A1 (DUFIT REMI [FR] ET AL) 2 September 2004 (2004-09-02)	1,2,4-14
Y	paragraph [0009] paragraph [0041] - paragraph [0046] paragraph [0055] - paragraph [0065] figures 1-4(b), 7, 9(a)-9(c)	3
X	EP 0 468 506 A2 (ACOUSTIC IMAGING TECH [US]) 29 January 1992 (1992-01-29)	1,2,4-14
A	column 3, line 47 - line 57 column 5, line 40 - line 48 column 8, line 47 - column 10, line 47 figures 1a, 1b, 3, 4, 8	3
	----- -/--	

 Further documents are listed in the continuation of Box C. See patent family annex.

## \* Special categories of cited documents :

"A" document defining the general state of the art which is not considered to be of particular relevance  
"E" earlier document but published on or after the international filing date  
"L" document which may throw doubts on priority claim(s) or which is cited to establish the publication date of another citation or other special reason (as specified)  
"O" document referring to an oral disclosure, use, exhibition or other means  
"P" document published prior to the international filing date but later than the priority date claimed

"T" later document published after the international filing date or priority date and not in conflict with the application but cited to understand the principle or theory underlying the invention  
"X" document of particular relevance; the claimed invention cannot be considered novel or cannot be considered to involve an inventive step when the document is taken alone  
"Y" document of particular relevance; the claimed invention cannot be considered to involve an inventive step when the document is combined with one or more other such documents, such combination being obvious to a person skilled in the art.  
"&" document member of the same patent family

Date of the actual completion of the international search

7 December 2010

Date of mailing of the international search report

14/12/2010

Name and mailing address of the ISA/

European Patent Office, P.B. 5818 Patentlaan 2  
NL - 2280 HV Rijswijk  
Tel. (+31-70) 340-2040,  
Fax: (+31-70) 340-3016

Authorized officer

Dydenko, Igor

## INTERNATIONAL SEARCH REPORT

International application No

PCT/IB2010/053858

C(Continuation). DOCUMENTS CONSIDERED TO BE RELEVANT		
Category*	Citation of document, with indication, where appropriate, of the relevant passages	Relevant to claim No.
X	EP 0 090 567 A1 (FUJITSU LTD [JP]) 5 October 1983 (1983-10-05) page 22 page 26 - page 29 figures 10, 11, 14	1-14
Y	WO 03/000137 A1 (BAE SYSTEMS INFORMATION [US]) 3 January 2003 (2003-01-03)	3
A	page 21, line 4 - line 19 figures 9, 23	1,2,4-14
A	US 5 797 845 A (BARABASH LEONID S [US] ET AL) 25 August 1998 (1998-08-25) the whole document	1,12
A	US 3 881 164 A (KOSSOFF GEORGE) 29 April 1975 (1975-04-29) the whole document	1,12
A	US 4 870 867 A (SHAULOV AVNER [US]) 3 October 1989 (1989-10-03) the whole document	1,12

# INTERNATIONAL SEARCH REPORT

Information on patent family members

International application No PCT/IB2010/053858
---

Patent document cited in search report	Publication date	Publication date	Patent family member(s)	Publication date
US 2004168517	A1	02-09-2004	NONE	
EP 0468506	A2	29-01-1992	DE 69120735 D1 DE 69120735 T2 US 5103129 A	14-08-1996 20-02-1997 07-04-1992
EP 0090567	A1	05-10-1983	DE 3377530 D1 US 4570488 A US 4580451 A	01-09-1988 18-02-1986 08-04-1986
WO 03000137	A1	03-01-2003	NONE	
US 5797845	A	25-08-1998	NONE	
US 3881164	A	29-04-1975	NONE	
US 4870867	A	03-10-1989	DE 68921860 D1 EP 0376396 A2 JP 2213331 A	27-04-1995 04-07-1990 24-08-1990

专利名称(译)	具有大视场的超声探头和制造这种超声探头的方法		
公开(公告)号	<a href="#">EP2473111A1</a>	公开(公告)日	2012-07-11
申请号	EP2010762750	申请日	2010-08-27
[标]申请(专利权)人(译)	皇家飞利浦电子股份有限公司		
申请(专利权)人(译)	皇家飞利浦电子N.V.		
当前申请(专利权)人(译)	皇家飞利浦N.V.		
[标]发明人	ROBINSON ANDREW L		
发明人	ROBINSON, ANDREW, L.		
IPC分类号	A61B8/00 G01S15/89		
CPC分类号	A61B8/00 A61B8/145 A61B8/4461 A61B8/4483 A61B8/4494 G01S15/8929 Y10T29/49005		
优先权	61/239497 2009-09-03 US		
其他公开文献	EP2473111B1		
外部链接	<a href="#">Espacenet</a>		

#### 摘要(译)

提出了一种用于超声探头的超声换能器矩阵阵列，其在方位角和仰角方向上具有大视场。超声换能器矩阵阵列 ( 1 ) 包括中心区域 ( 11 ) 和至少三个分支区域 ( 13 ) ，每个分支区域包括超声换能器元件 ( 3 ) 的二维矩阵阵列 ( 5 ) 。中心区域包括至少三个边缘 ( 15 ) ，相应的分支区域从该边缘延伸。每个分支区域 ( 13 ) 围绕平行于中心区域 ( 11 ) 的边缘 ( 15 ) 的轴线弯曲，相应的分支区域 ( 13 ) 从该边缘延伸。利用包括这样的超声换能器区域的超声探头，其具有通过共同的，优选平坦的中心区域互连的分支区域，可以近似具有球形形状的视场的理想矩阵阵列。