

(19) World Intellectual Property Organization
International Bureau



(43) International Publication Date
4 December 2003 (04.12.2003)

(10) International Publication Number
PCT
WO 03/099126 A1

- (51) International Patent Classification⁷: A61B 8/00, A47B 21/03
- (21) International Application Number: PCT/IB03/02158
- (22) International Filing Date: 21 May 2003 (21.05.2003)
- (25) Filing Language: English
- (26) Publication Language: English
- (30) Priority Data: 10/155,504 23 May 2002 (23.05.2002) US
- (71) Applicant: KONINKLIJKE PHILIPS ELECTRONICS N.V. [NL/NL]; Groenewoudseweg 1, NL-5621 BA Eindhoven (NL).
- (72) Inventors: MESAROS, Robert; c/o Prof. Holstlaan 6, NL-5656 AA Eindhoven (NL). MATSUI, Yas; c/o Prof. Holstlaan 6, NL-5656 AA Eindhoven (NL).
- (74) Agent: LOTTIN, Claudine; Internationaal Octrooibureau B.V., Prof. Holstlaan 6, NL-5656 AA Eindhoven (NL).
- (81) Designated States (*national*): AE, AG, AL, AM, AT, AU, AZ, BA, BB, BG, BR, BY, BZ, CA, CH, CN, CO, CR, CU, CZ, DE, DK, DM, DZ, EC, EE, ES, FI, GB, GD, GE, GH, GM, HR, HU, ID, IL, IN, IS, JP, KE, KG, KP, KR, KZ, LC, LK, LR, LS, LT, LU, LV, MA, MD, MG, MK, MN, MW, MX, MZ, NI, NO, NZ, OM, PH, PL, PT, RO, RU, SC, SD, SE, SG, SK, SL, TJ, TM, TN, TR, TT, TZ, UA, UG, UZ, VC, VN, YU, ZA, ZM, ZW.
- (84) Designated States (*regional*): ARIPO patent (GH, GM, KE, LS, MW, MZ, SD, SL, SZ, TZ, UG, ZM, ZW), Eurasian patent (AM, AZ, BY, KG, KZ, MD, RU, TJ, TM), European patent (AT, BE, BG, CH, CY, CZ, DE, DK, EE, ES, FI, FR, GB, GR, HU, IE, IT, LU, MC, NL, PT, RO, SE, SI, SK, TR), OAPI patent (BF, BJ, CF, CG, CI, CM, GA, GN, GQ, GW, ML, MR, NE, SN, TD, TG).

Declaration under Rule 4.17:

— as to the applicant's entitlement to claim the priority of the earlier application (Rule 4.17(iii)) for the following designation CN

[Continued on next page]

(54) Title: CARD WITH INTEGRAL WRIST PAD FOR AN ULTRASOUND EXAMINATION SYSTEM

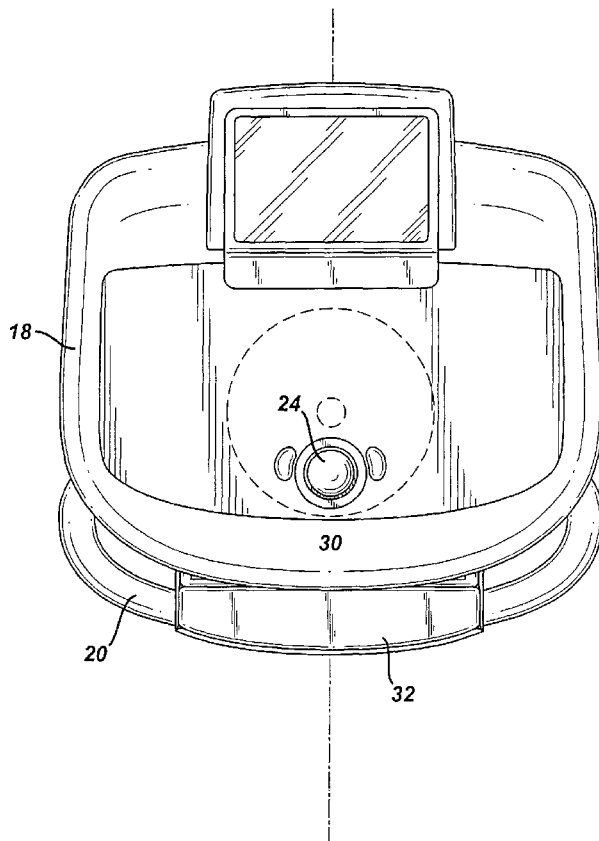

(57) Abstract: A control panel for an examination ultrasound system includes a keyboard with a wrist pad that stows beneath the control panel, and extends from the control panel when needed. The keyboard wrist pad integrates smoothly into the front of the control panel when the keyboard is in the stowed position. The keyboard wrist pad can also be integrated into the top surface of the edge of the control panel and can serve as a wrist pad for either the control panel or the keyboard when the keyboard is extended.



WO 03/099126 A1



Published:

— with international search report

For two-letter codes and other abbreviations, refer to the "Guidance Notes on Codes and Abbreviations" appearing at the beginning of each regular issue of the PCT Gazette.

CART WITH INTEGRAL WRIST PAD FOR AN ULTRASOUND EXAMINATION SYSTEM

This invention relates to ultrasonic examination imaging systems and, in particular, to ultrasound systems with integral wrist support pads.

Cart-borne ultrasound systems should be compact and easy to roll to a examination lab or patient bedside. In use, these systems should be comfortable and
5 convenient for the clinician to operate. Typically, such ultrasound systems have a control panel by which the clinician adjusts the features and performance of the system. These systems also generally have a keyboard by which the clinician can type in patient information and notations on images and reports produced by the system. In the past the keyboard has generally been made a part of the control panel, thereby presenting the full range of controls
10 including the keyboard immediately in front of the operator. For a more compact design, it is desirable to integrate the control panel and keyboard together. For instance, if the keyboard is mounted beneath the control panel on a sliding drawer, the drawer and keyboard can be pulled out from under the control panel when needed, and rolled back under the control panel when not in use. Such an arrangement allows the control panel to be made smaller and more
15 compact, as the keyboard is not a part of the control panel surface.

The clinician can spend many hours during the day operating the ultrasound system. To guard against fatigue and repetitive stress injuries and to afford comfort to the user, it is desirable to provide a support for the clinician's hand or arm while operating the ultrasound system. Such a support should be convenient to use as well as providing the
20 necessary support, and should not detract from a clean and elegant system design.

In accordance with the principles of the present invention, an ultrasound system control panel has the keyboard integrated into the control panel structure. The keyboard slides out from beneath the control panel for use, and slides back under the control panel when not needed. The control panel has a wrist pad to support the operator's hand
25 when operating the control panel. The keyboard is integrated into this wrist pad and has its own wrist pad when extended for use. Alternatively, the keyboard wrist pad can serve both the keyboard and the control panel. When the keyboard and its wrist pad are partially extended, the keyboard wrist pad provides an adjustable wrist pad for larger hands.

In the drawings:

FIGURE 1 illustrates a cart-borne ultrasound system in perspective;

FIGURES 2 through 6a illustrate a first embodiment of the present invention
5 in which a keyboard is integrated into the wrist pad of an ultrasound system control panel;
and

FIGURES 7 through 10 illustrate a second embodiment of the present
invention in which a keyboard is integrated into the wrist pad of the control panel and has a
wrist pad which may be used for either the control panel or the keyboard.

10

Referring first to FIGURE 1, a cart-borne ultrasound system 10 is shown in
perspective. The cart includes an electronics bay 12 inside of which are located printed
circuit boards for electronically processing received ultrasound signals. The ultrasound
15 signals are processed to produce an image which is displayed on a display 16. The cart is
mounted on wheels or casters 14 so that it can be rolled to a lab or a patient's bedside. In the
front of the cart is a control panel 18, which contains a number of knobs, buttons, slide
switches, and a trackball by which a user controls the operation of the ultrasound system.
The control panel is mounted above a handle 20 which extends from the front of the
20 ultrasound system. The handle 20 can be used to pull the cart to move it from one location to
another. On the inside of the handle 20 is a lift release button 22 which unlocks a lift
mechanism 42 for the control panel, enabling the control panel to be raised or lowered to an
elevation which is comfortable for the user. The lift mechanism is more fully described in
concurrently filed US patent [application serial number ATL-294] the subject matter of
25 which is incorporated herein by reference.

FIGURE 2 illustrates an ultrasound system control panel constructed in
accordance with the principles of a first embodiment of the present invention. Located in the
front of the control panel 18, and preferably extending around the periphery of the control
panel, is a wrist pad 30. The wrist pad 30 supports the base of the palm or wrist of the user's
30 hand when operating the controls located on the control area 36 of the control panel 18. The
wrist pad wraps over the front of the control panel, in which there is a recess 34. Located in
the recess 34 is a keyboard for the ultrasound system with its own wrist pad 32. As FIGURE
2 illustrates, the wrist pad 32 for the keyboard is smoothly integrated into the front of the

control panel wrist pad 30, providing a clean and compact design appearance when the keyboard is stored under the control panel.

FIGURE 2a is a plan view of the control panel 18 of FIGURE 2, which also shows the handle 20. In a preferred embodiment the control panel can articulate laterally to conform to the location of the user at one side of the ultrasound system cart or the other, as described more fully in concurrently filed US patent [application serial number ATL-296]. When the control panel is in its nominal center position it is centered about the center line of the ultrasound system as shown in FIGURE 1. FIGURE 2a also shows the location of a trackball 24 on the control panel 18 just in front of the wrist pad 30. As is evident from the drawing, the user can rest his or her wrist on the wrist pad 30 while manipulating the trackball 24 or control buttons 25,26 located around the trackball.

FIGURE 3 shows the control panel 18 and handle 20 with the keyboard withdrawn a small distance from its stored location under the control panel. The wrist pad 32 of the keyboard is seen extending in front of the control panel. In FIGURE 4 the keyboard 50 is extended further from the recess in the control panel wrist pad and is partially visible. In FIGURE 5 the keyboard 50 is extended even further from the recess 34, and in FIGURES 6 and 6a the keyboard 50 is shown fully extended from the control panel. As these latter drawings illustrate, the keyboard may be operated while the user's wrists are supported on the keyboard wrist pad 32, and the trackball 24 and controls of the control panel can be operated with the user's wrist supported on the control panel wrist pad 30. When the user is finished using the keyboard 50, it can be stowed back in the recess 34 as the user continues to operate the controls on the control panel with a wrist or hand supported on the wrist pad 30.

FIGURE 7 shows the control panel 18 with keyboard 50 extended when the control panel has been moved laterally to one side of the cart. This drawing and previous drawings show a swivel plate 70 in phantom which pivots about a pivot point 72. The control panel and keyboard are mounted for lateral articulation on a track (not shown) which allows the control panel and keyboard to be moved laterally to be centered about dashed line 62 as opposed to the nominal center line 60. At any point in its lateral path of travel the control panel and keyboard can be swiveled by means of the swivel plate 70 on which the control panel is mounted. This lateral articulation and swiveling of the control panel is more fully described in concurrently filed US patent [application serial number ATL-296] which is incorporated herein by reference. This combination of raising and lowering, lateral articulation and swiveling permit the control panel and keyboard with their wrist pads to be located in a position most comfortable for a wide variety of users.

FIGURE 8 illustrates a second embodiment of the present invention in which the wrist pad 32 of the keyboard is integrated into the front of the control panel 18 where it serves as a wrist pad for both the control panel and keyboard. The keyboard wrist pad 32 extends along the front of the control panel 18 and wraps up on top of the keyboard so as to provide a wrist pad for use when operating the trackball 24 and other controls on the control area 36, as shown in FIGURE 8a. That drawing shows the hand 100 of a user manipulating the trackball 24 while resting the base of the hand on the wrist pad 32. Since the keyboard wrist pad serves as a wrist pad for the trackball and nearby controls of the control panel 18, it is not necessary that the molding 38 around the edge of the control panel be made of wrist pad material. The molding may if desired be made of a more durable rubberlike or polymeric material, preferably one with an appearance that matches that of the wrist pad 38 for a clean control panel appearance.

An additional benefit of using the keyboard wrist pad 32 to serve as the control panel wrist pad is that the movable keyboard allows the position of the wrist pad to be adjusted for different hand sizes. For instance, FIGURE 9 shows the keyboard and its wrist pad 32 slightly extended from the recess in the front of the control panel 18, as indicated by the arrows 64,66. As FIGURE 9a shows, in this extended position the wrist pad 32 can accommodate a larger hand 102 of a user. A compact control panel design can thus serve to provide wrist support for a wide variety of users.

Finally, FIGURE 10 illustrates the keyboard 50 and wrist pad 32 in a fully extended position, in which the user would be using the keyboard 50 while resting the wrist or base of the hand on the wrist pad 32.

Other variations will readily occur to those skilled in the art. For example, instead of or in addition to sliding straight out from the front of the control panel, the keyboard may be given other directions of movement. The keyboard can be mounted on a track or linkage similar to those described for the control panel in the concurrently filed US patent [application serial number ATL-296], which would enable the keyboard to move laterally from left to right with respect to the control panel. This articulation would enable the keyboard to be moved to one side of the control panel so that the user can be in close proximity to the control panel when the keyboard is extended. In FIGURE 7, for instance, lateral articulation of the control panel 50 either linearly or along a curved path would enable the user to push the keyboard to one side and be able to sit close to the control panel while the keyboard is extended for use.

CLAIMS:

1. An ultrasonic examination imaging system (10) including a control panel (18) by which the ultrasonic imaging system (10) may be controlled, comprising:
a control panel wrist pad (30) located on the front of the control panel(18); and
a keyboard (50) having a wrist pad (32) on the front of the keyboard (50), the
5 keyboard (50) being extendable from beneath the control panel (18), the keyboard wrist pad (32) being integrated into the form of the control panel wrist pad (30).
2. The ultrasonic examination imaging system (10) of Claim 1, wherein the
control panel wrist pad (30) has a top surface which supports a hand or wrist while operating
10 a control panel control; the control panel (30) also having a front surface recess (34) from
which the keyboard (50) may be extended.
3. The ultrasonic examination imaging system (10) of Claim 2, wherein the
keyboard wrist pad (32) has a front surface which integrates into the front surface of the
15 control panel (18) when the keyboard (50) is retracted into the front surface recess (34) of the
control panel (18).
4. The ultrasonic examination imaging system (10) of Claim 1, further
comprising a cart upon which the ultrasonic examination imaging system is mounted,
20 wherein the control panel (18) and keyboard (50) are movably mounted to
swivel and articulate laterally with respect to the cart.
5. An ultrasonic examination imaging system (10) including a control panel (18)
by which the ultrasonic imaging system (10) may be controlled, comprising:
25 a keyboard (50) movably mounted to retract or extend from beneath the
control panel (18), the keyboard (50) having a wrist pad (32) which may support the hand or
wrist of a user while operating a control on the control panel (18) or the keyboard (50).

6. The ultrasonic examination imaging system (10) of Claim 5, wherein the keyboard wrist pad (32) retracts into or extends from the control panel (18) as the keyboard (50) is moved.
- 5 7. The ultrasonic examination imaging system (10) of Claim 5, wherein the keyboard wrist pad (32) has a top surface which serves as a wrist pad while operating a control on the control panel (18) when the keyboard (50) is in the retracted position, the keyboard wrist pad (32) top surface serving as a wrist pad while operating the keyboard (50) when the keyboard (50) is in the extended position.
- 10 8. The ultrasonic examination imaging system (10) of Claim 5, wherein the control panel (18) includes a front edge into which the keyboard wrist pad (32) integrates when the keyboard (50) is in the retracted position.

FIG. 1

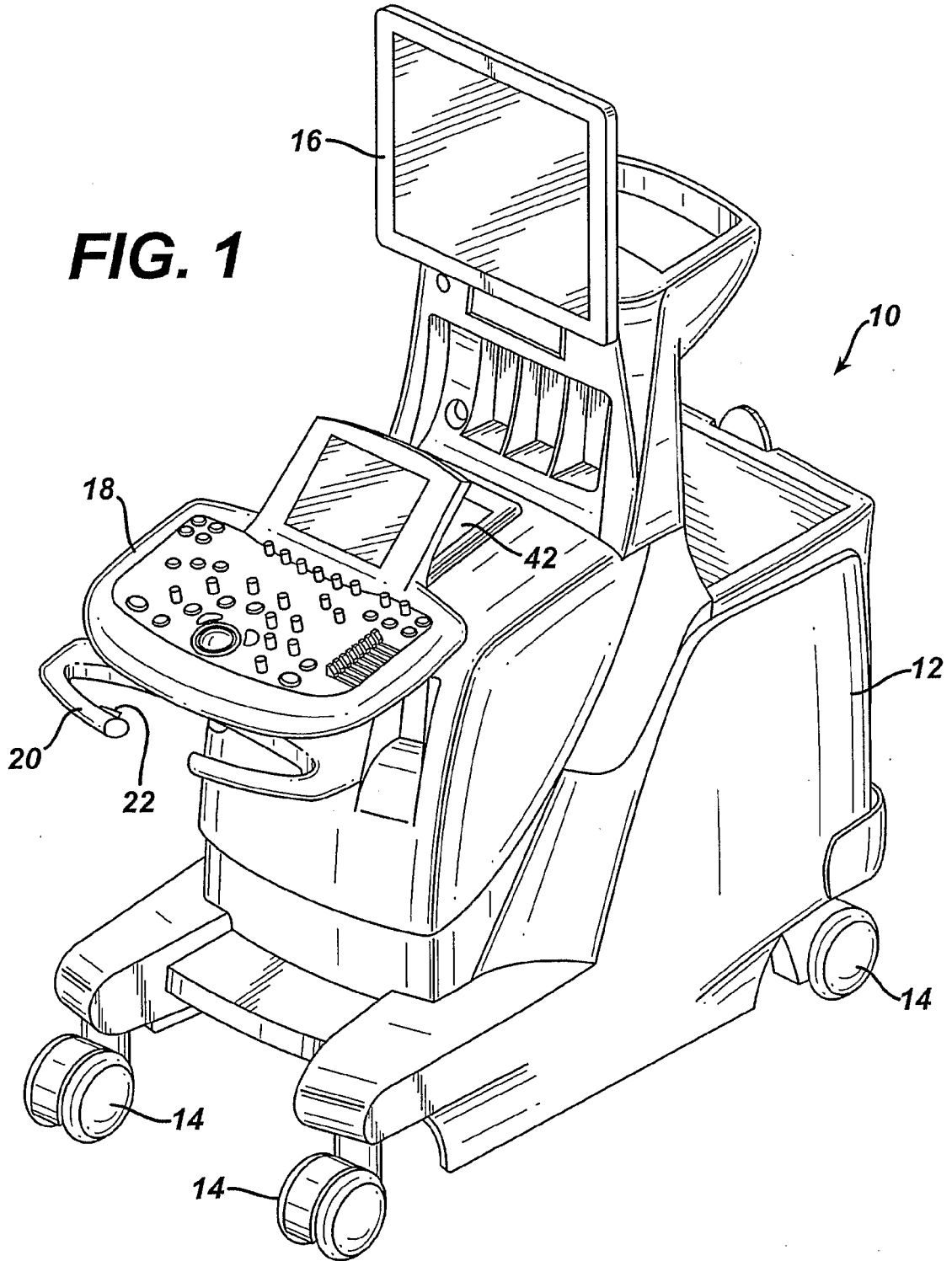

FIG. 2

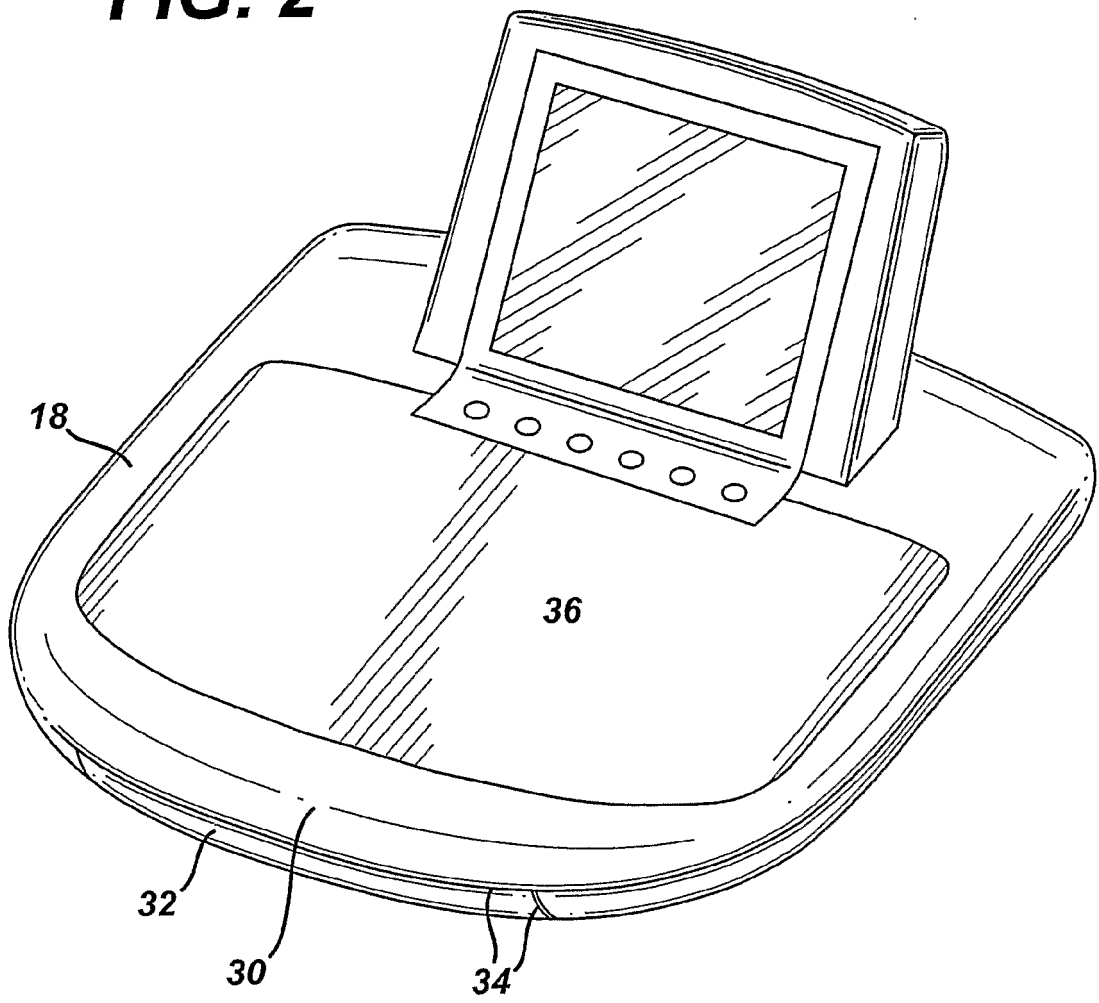

FIG. 2a

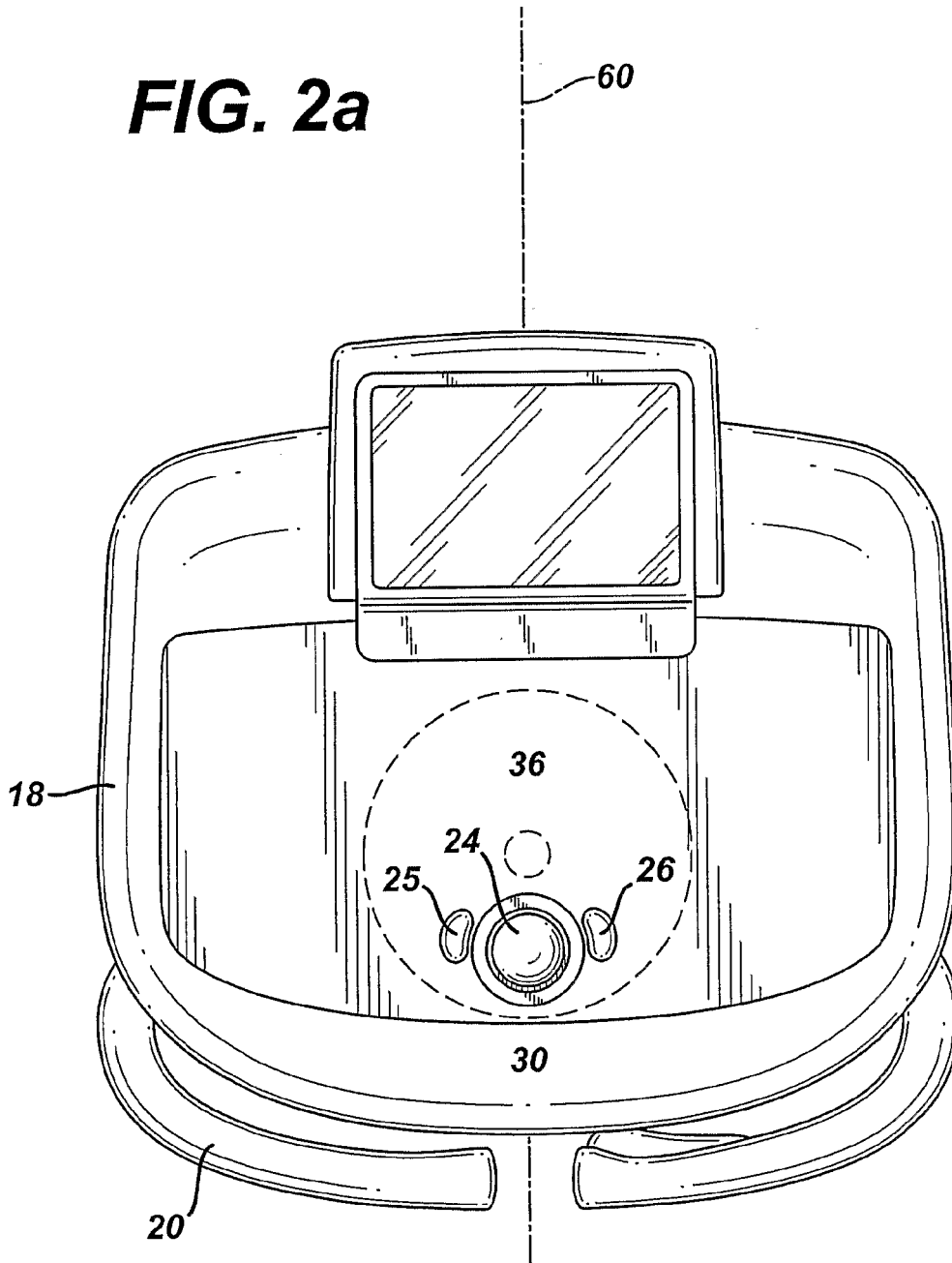
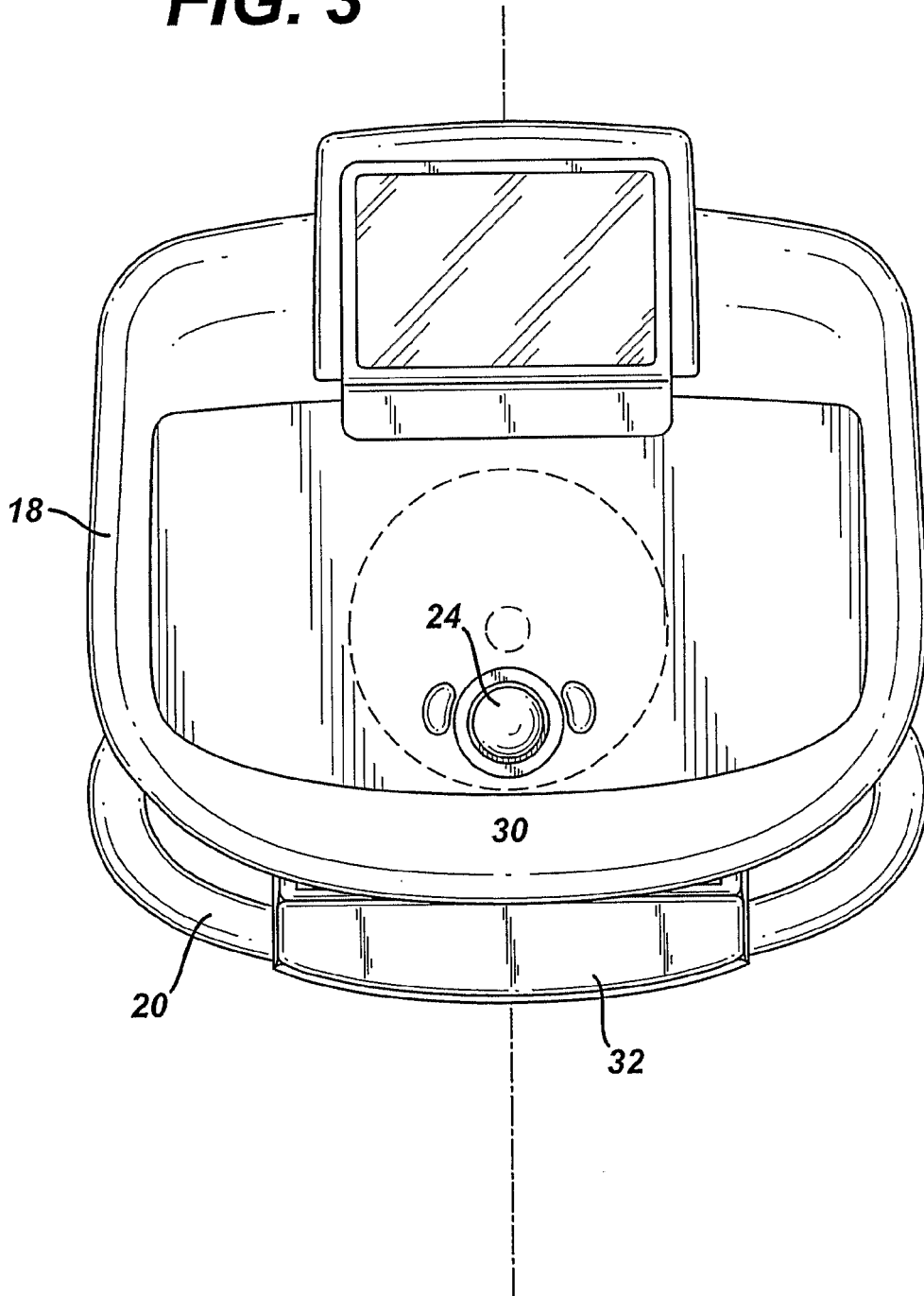

FIG. 3



5/12

FIG. 4

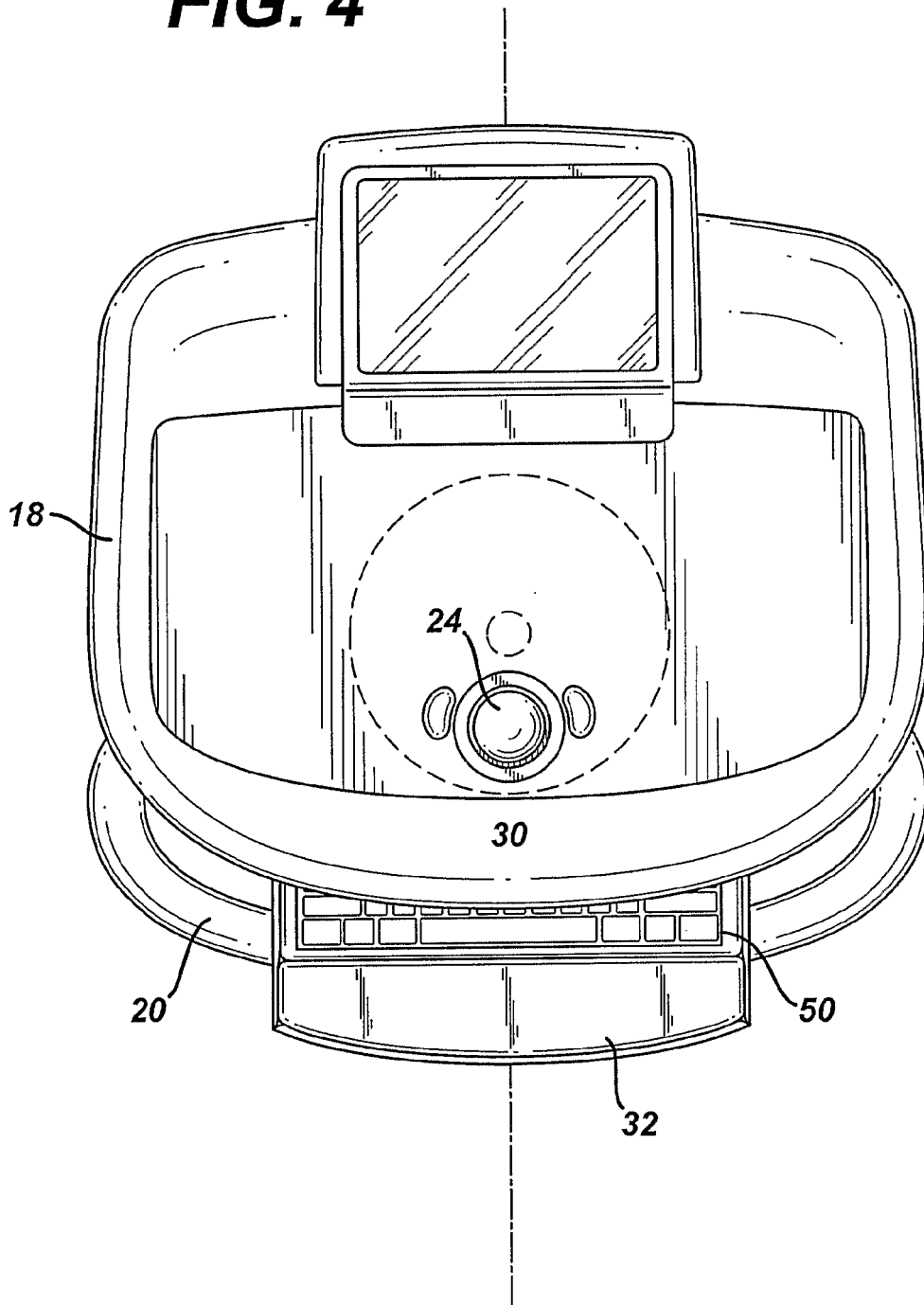

FIG. 5

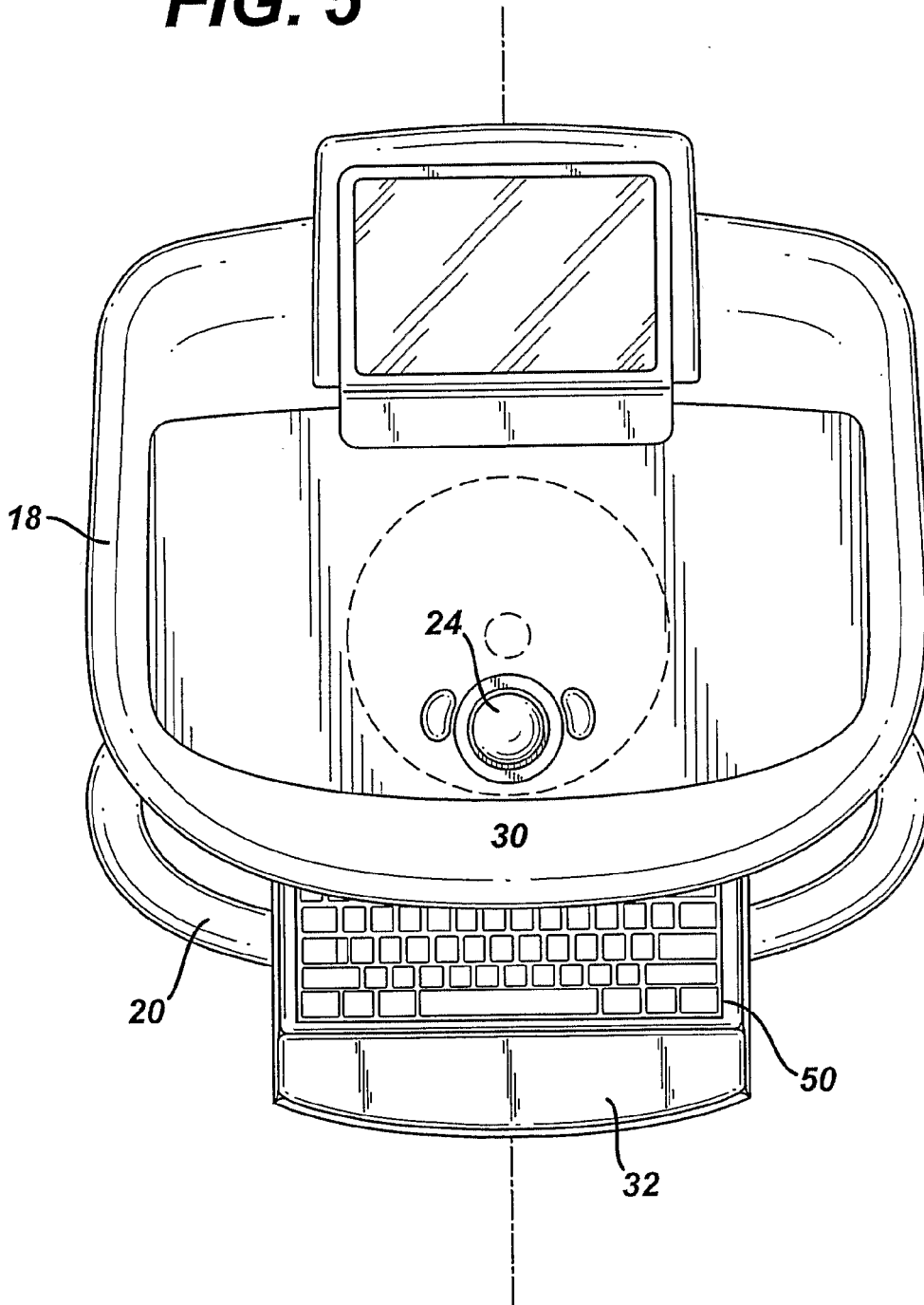

FIG. 6

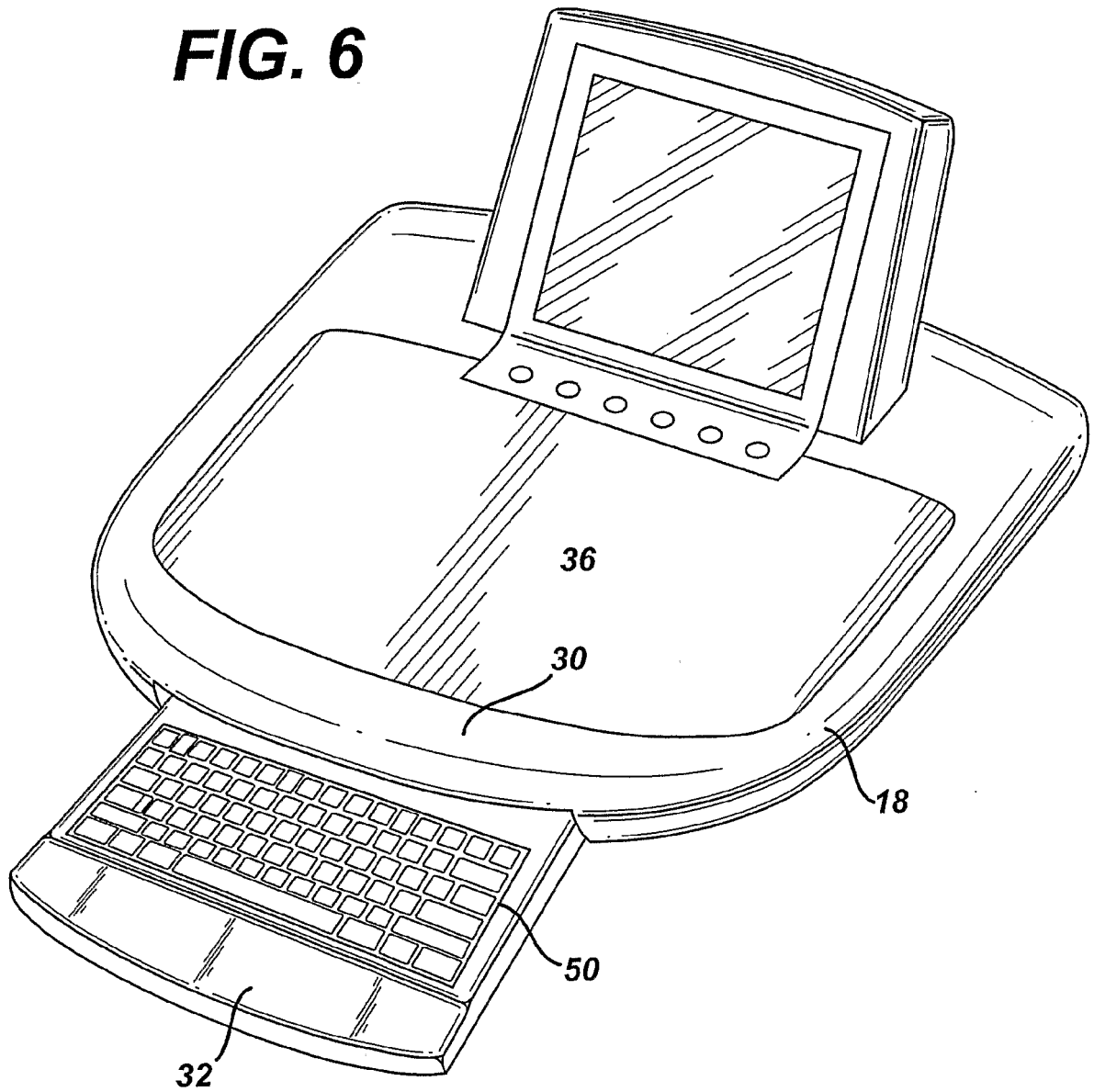
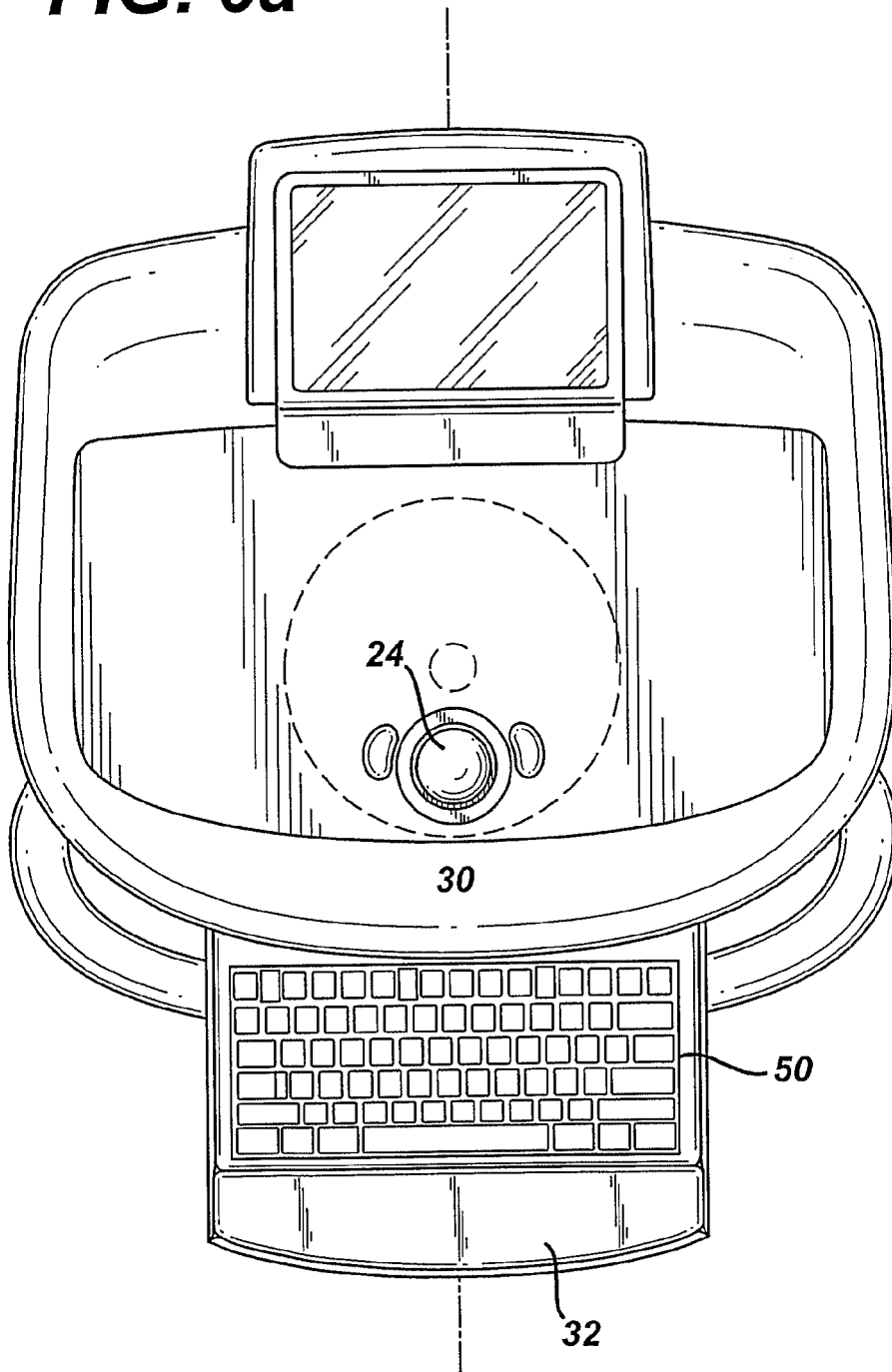
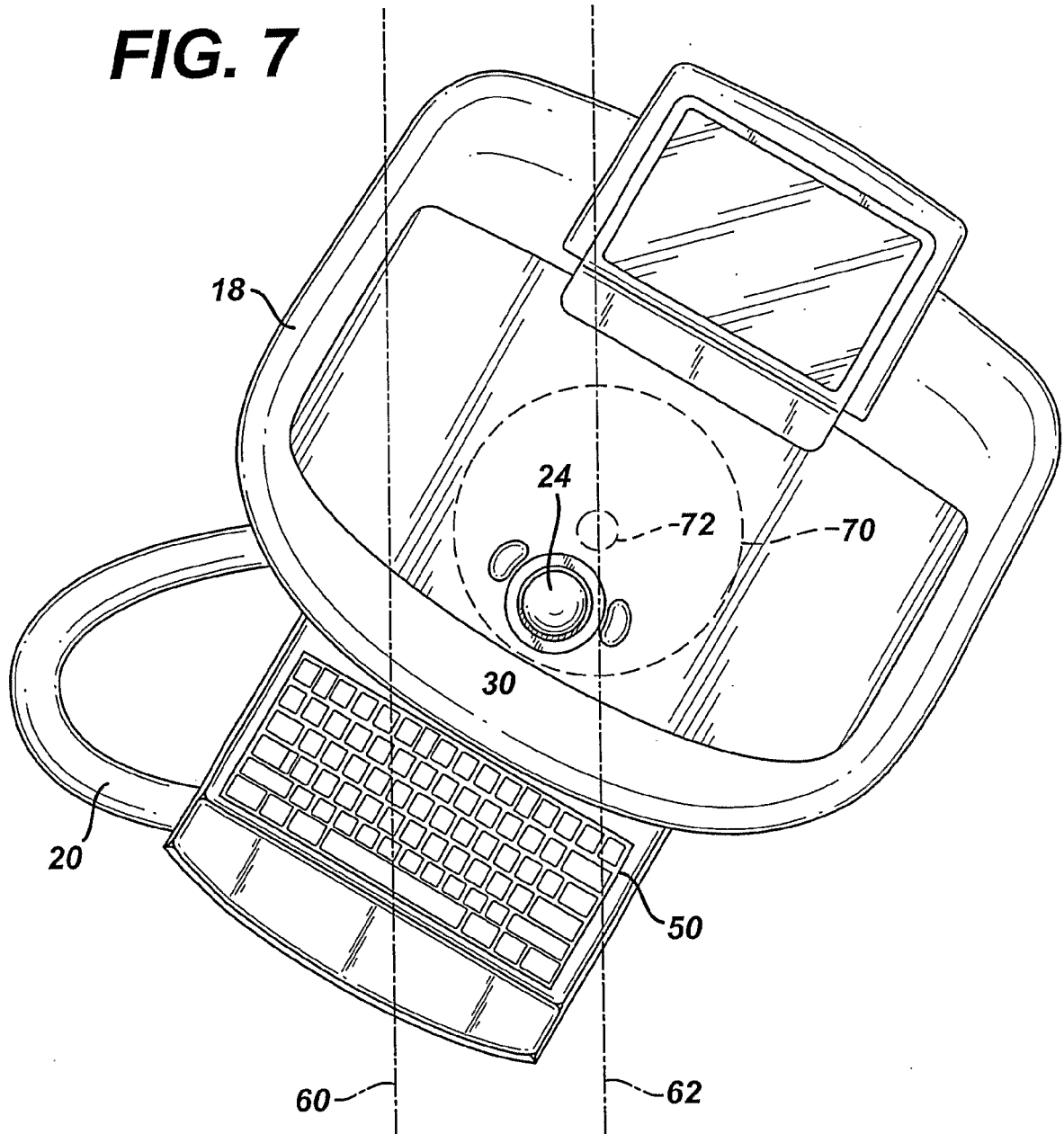

FIG. 6a



9/12

FIG. 7



10/12

FIG. 8

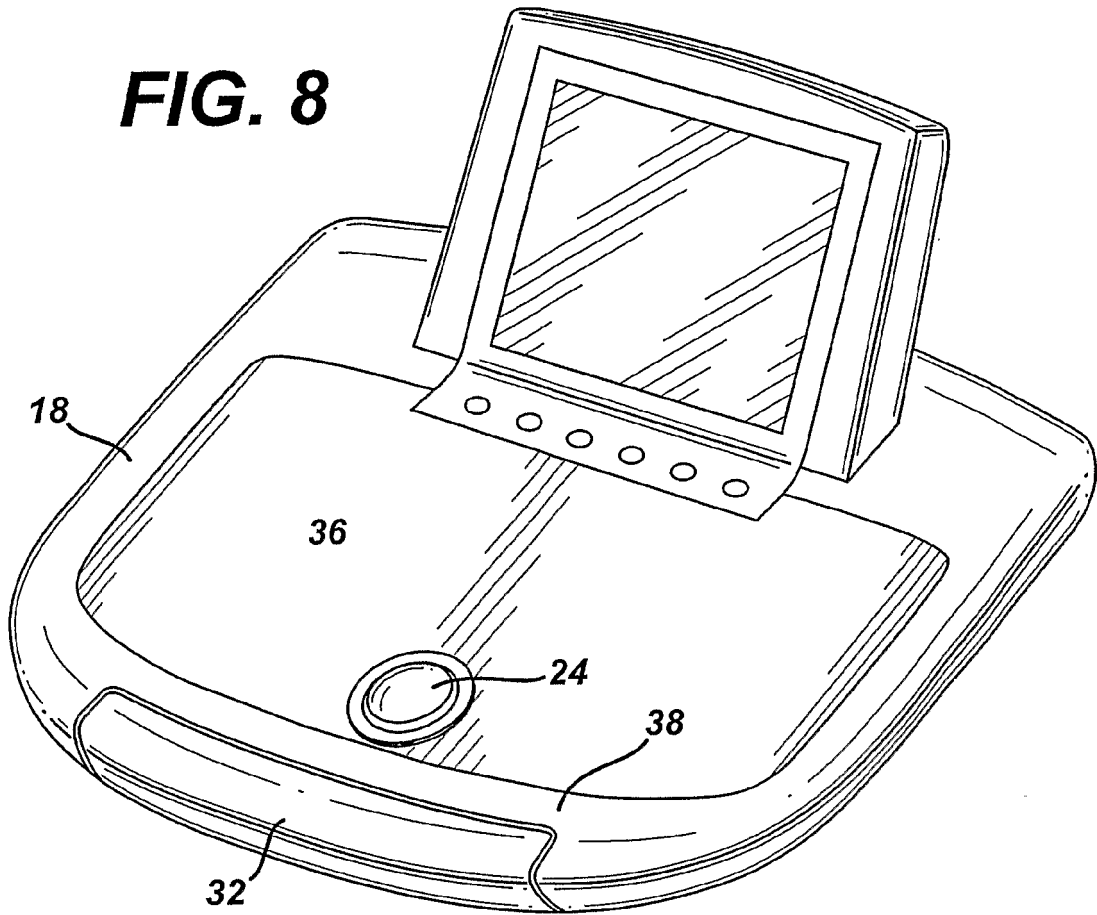
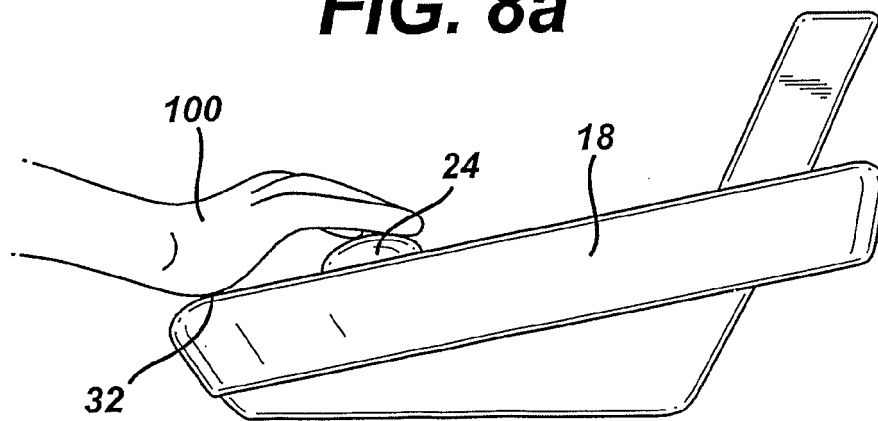

FIG. 8a



11/12

FIG. 9

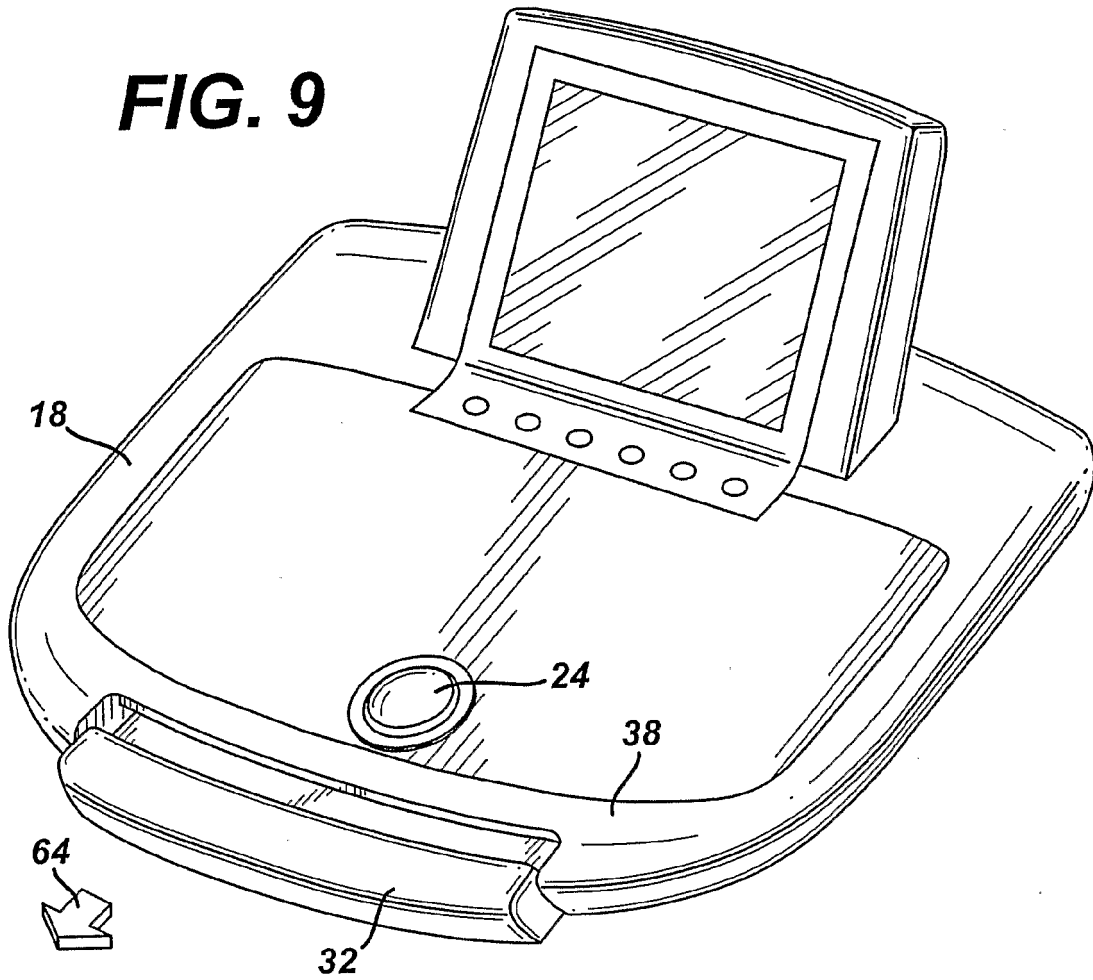

FIG. 9a

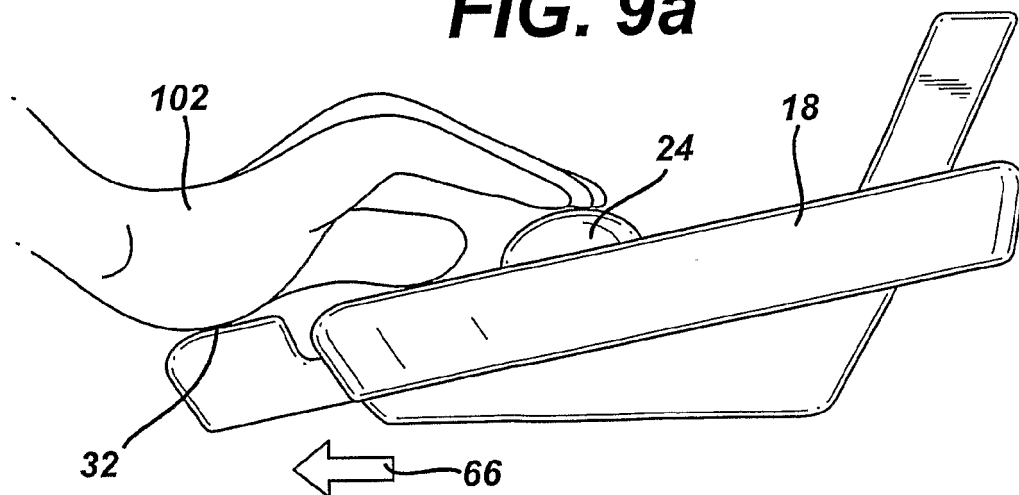
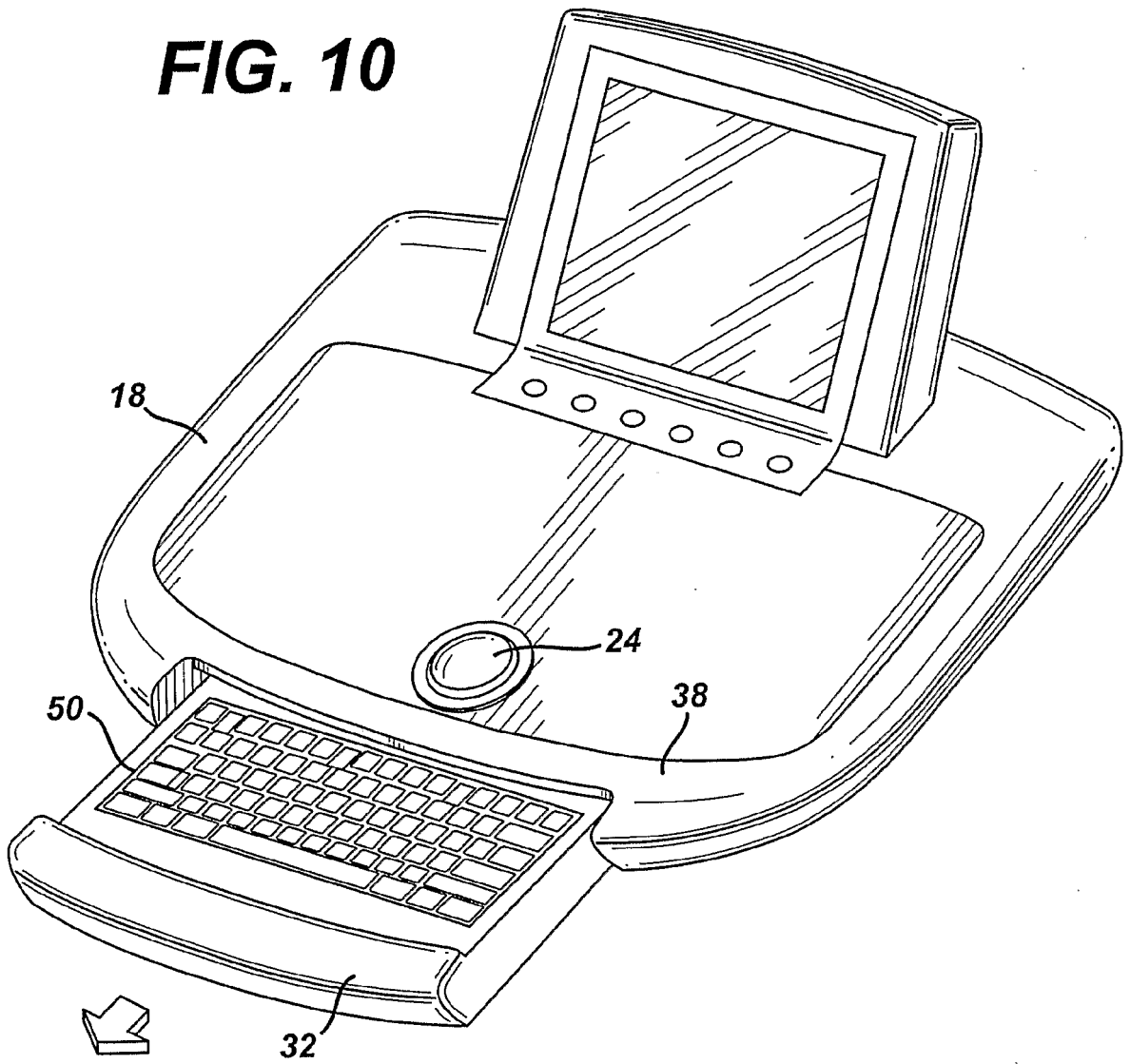

FIG. 10



INTERNATIONAL SEARCH REPORT

International Application No
PCT/IB 03/02158

A. CLASSIFICATION OF SUBJECT MATTER
IPC 7 A61B8/00 A47B21/03

According to International Patent Classification (IPC) or to both national classification and IPC

B. FIELDS SEARCHED

Minimum documentation searched (classification system followed by classification symbols)
IPC 7 A61B A47B G06F G01S

Documentation searched other than minimum documentation to the extent that such documents are included in the fields searched

Electronic data base consulted during the international search (name of data base and, where practical, search terms used)

C. DOCUMENTS CONSIDERED TO BE RELEVANT

Category °	Citation of document, with indication, where appropriate, of the relevant passages	Relevant to claim No.
X	WO 00 19907 A (BOSTON SCIENT LTD) 13 April 2000 (2000-04-13)	1-3,5-8
Y	page 3, line 7 - line 26 page 6, line 29 - line 36; figures 1,2	4
Y	EP 0 415 323 A (TOKYO SHIBAURA ELECTRIC CO) 6 March 1991 (1991-03-06) column 4, line 19 -column 7, line 7; figures 2,6,7	4
A	US 4 870 954 A (SATOH TOMOHIRO) 3 October 1989 (1989-10-03) column 2, line 14 -column 3, line 59; figures 1,2A-B	1-8
	-/--	

Further documents are listed in the continuation of box C.

Patent family members are listed in annex.

° Special categories of cited documents :

- *A* document defining the general state of the art which is not considered to be of particular relevance
- *E* earlier document but published on or after the international filing date
- *L* document which may throw doubts on priority claim(s) or which is cited to establish the publication date of another citation or other special reason (as specified)
- *O* document referring to an oral disclosure, use, exhibition or other means
- *P* document published prior to the international filing date but later than the priority date claimed

- *T* later document published after the international filing date or priority date and not in conflict with the application but cited to understand the principle or theory underlying the invention
- *X* document of particular relevance; the claimed invention cannot be considered novel or cannot be considered to involve an inventive step when the document is taken alone
- *Y* document of particular relevance; the claimed invention cannot be considered to involve an inventive step when the document is combined with one or more other such documents, such combination being obvious to a person skilled in the art.
- * & * document member of the same patent family

Date of the actual completion of the international search

Date of mailing of the international search report

12 September 2003

19/09/2003

Name and mailing address of the ISA
European Patent Office, P.B. 5818 Patentlaan 2
NL - 2280 HV Rijswijk
Tel. (+31-70) 340-2040, Tx. 31 651 epo nl,
Fax: (+31-70) 340-3016

Authorized officer

Artikis, T

INTERNATIONAL SEARCH REPORT

International Application No

PCT/IB 03/02158

C.(Continuation) DOCUMENTS CONSIDERED TO BE RELEVANT		
Category °	Citation of document, with indication, where appropriate, of the relevant passages	Relevant to claim No.
A	PATENT ABSTRACTS OF JAPAN vol. 014, no. 509 (C-0776), 7 November 1990 (1990-11-07) -& JP 02 211133 A (TERUMO CORP), 22 August 1990 (1990-08-22) abstract; figures 1-4 -----	1-3,5,6, 8
A	DE 41 03 843 A (LOH KG RITTAL WERK) 14 August 1991 (1991-08-14) column 2, line 7 - line 57; figures 1,3 -----	1-3,5,6, 8

INTERNATIONAL SEARCH REPORT

International Application No
PCT/IB 03/02158

Patent document cited in search report		Publication date	Patent family member(s)	Publication date
WO 0019907	A	13-04-2000	US 6142940 A	07-11-2000
			CA 2344229 A1	13-04-2000
			WO 0019907 A1	13-04-2000
			EP 1119294 A1	01-08-2001
			JP 2002526144 T	20-08-2002
			US 6361497 B1	26-03-2002
			US 6358207 B1	19-03-2002
EP 0415323	A	06-03-1991	JP 3109620 A	09-05-1991
			JP 3128224 B2	29-01-2001
			DE 69017799 D1	20-04-1995
			DE 69017799 T2	07-12-1995
			EP 0415323 A2	06-03-1991
			KR 9305952 B1	30-06-1993
			US 5129397 A	14-07-1992
US 4870954	A	03-10-1989	JP 63318930 A	27-12-1988
			DE 3821074 A1	05-01-1989
JP 02211133	A	22-08-1990	JP 1925731 C	25-04-1995
			JP 6053114 B	20-07-1994
DE 4103843	A	14-08-1991	DE 4004262 C1	25-04-1991
			DE 4103843 A1	14-08-1991
			FR 2658368 A1	16-08-1991
			IT 1245105 B	13-09-1994

专利名称(译)	带有整体腕垫的推车，用于超声检查系统		
公开(公告)号	EP1509135A1	公开(公告)日	2005-03-02
申请号	EP2003725515	申请日	2003-05-21
[标]申请(专利权)人(译)	皇家飞利浦电子股份有限公司		
申请(专利权)人(译)	皇家飞利浦电子N.V.		
当前申请(专利权)人(译)	皇家飞利浦电子N.V.		
[标]发明人	MESAROS ROBERT MATSUI YAS		
发明人	MESAROS, ROBERT MATSUI, YAS		
IPC分类号	A61B8/00 A47B21/03		
CPC分类号	A61B8/4405 A61B8/00 A61B8/462 A61B8/467 Y10S248/918		
优先权	10/155504 2002-05-23 US		
外部链接	Espacenet		

摘要(译)

用于检查超声系统的控制面板包括具有腕垫的键盘，该腕垫收纳在控制面板下方，并且在需要时从控制面板延伸。当键盘处于收起位置时，键盘腕垫可平滑地集成到控制面板的前部。键盘腕垫也可以集成到控制面板边缘的顶部表面中，并且当键盘伸出时可以用作控制面板或键盘的腕垫。