



(11) **EP 3 315 077 A1**

(12) **EUROPEAN PATENT APPLICATION**
published in accordance with Art. 153(4) EPC

(43) Date of publication:
02.05.2018 Bulletin 2018/18

(51) Int Cl.:
A61B 8/12 (2006.01)

(21) Application number: **16814021.8**

(86) International application number:
PCT/JP2016/060836

(22) Date of filing: **31.03.2016**

(87) International publication number:
WO 2016/208250 (29.12.2016 Gazette 2016/52)

(84) Designated Contracting States:
AL AT BE BG CH CY CZ DE DK EE ES FI FR GB GR HR HU IE IS IT LI LT LU LV MC MK MT NL NO PL PT RO RS SE SI SK SM TR
Designated Extension States:
BA ME
Designated Validation States:
MA MD

(71) Applicant: **Olympus Corporation**
Hachioji-shi
Tokyo 192-8507 (JP)

(72) Inventor: **KITAHARA, Toshihiro**
Tokyo 192-8507 (JP)

(74) Representative: **Gunzelmann, Rainer**
Wuesthoff & Wuesthoff
Patentanwälte PartG mbB
Schweigerstraße 2
81541 München (DE)

(30) Priority: **23.06.2015 JP 2015126052**

(54) **ULTRASONIC ENDOSCOPE**

(57) An ultrasound endoscope according to the present invention includes an insertion portion to be inserted into a subject, and includes: an ultrasound functional unit provided at a distal end of the insertion portion, the ultrasound functional unit including an ultrasound transducer configured to transmit and receive an ultrasound wave on a surface including a longitudinal axis of the insertion portion, the surface being parallel to the longitudinal axis; and an endoscope functional unit connected to the ultrasound functional unit, the endoscope functional unit at least including: a balloon locking portion having a groove shape that can lock a balloon; and an

imaging optical system, wherein a first plane passes, in a direction of the longitudinal axis of the insertion portion, through an end portion of the ultrasound transducer near the endoscope functional unit, the first plane being perpendicular to the longitudinal axis of the insertion portion, and the first plane is positioned closer to a proximal end than a second plane passing through an end portion of the endoscope functional unit near the ultrasound functional unit, the end portion of the endoscope functional unit being a boundary between the ultrasound functional unit and the endoscope functional unit.

FIG.4

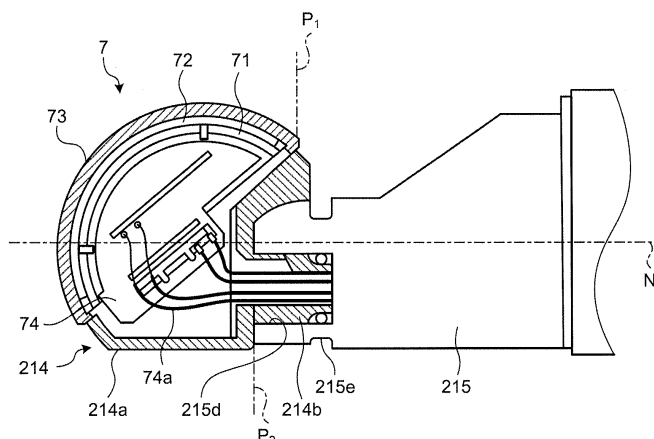

EP 3 315 077 A1

Description

Field

[0001] The present invention relates to an ultrasound endoscope including an ultrasound transducer that emits ultrasound waves onto an observation target, receives an ultrasound echo reflected by the observation target, converts the ultrasound echo into an echo signal, and outputs the echo signal.

Background

[0002] For observing the property of body tissue or material that is an observation target, ultrasound waves are applied in some cases. More particularly, an ultrasound observation apparatus can acquire information related to the property of the observation target, by performing predetermined signal processing on an ultrasound echo received from an ultrasound transducer that transmits and receives ultrasound waves.

[0003] The ultrasound transducer includes a plurality of piezoelectric elements that converts an electrical pulse signal into an ultrasound pulse (acoustic pulse), emits the ultrasound pulse onto the observation target, converts the ultrasound echo reflected by the observation target, into an electrical echo signal, and outputs the electrical echo signal. For example, by arranging a plurality of piezoelectric elements along a predetermined direction, and electrically switching an element involved in the transmission and reception, or delaying the transmission and reception of each element, an ultrasound echo is acquired from the observation target.

[0004] There are known a plurality of types of ultrasound transducers having different ultrasound-beam transmission and reception directions, such as a convex type, a linear type, and a radial type. Among these types, a convex-type ultrasound transducer includes a plurality of piezoelectric elements arrayed along a curved surface, and each element emits an ultrasound beam in a radial direction of the curved surface (e.g., refer to Patent Literature 1). Patent Literature 1 discloses a configuration in which a convex-type ultrasound transducer is provided at a distal end of an insertion portion of an ultrasound endoscope.

Citation List

Patent Literature

[0005] Patent Literature 1: JP 2004-254942 A

Summary

Technical Problem

[0006] Nevertheless, the ultrasound endoscope disclosed in Patent Literature 1 has such a problem that, if

a curvature radius of the curved surface of the convex-type ultrasound transducer (curved surface passing through distal ends of a plurality of piezoelectric elements) is increased, an extension length of the ultrasound transducer with respect to a longitudinal axis direction of the insertion portion becomes long.

[0007] The present invention has been devised in view of the foregoing, and the object of the present invention is to provide an ultrasound endoscope that can increase a curvature radius of an ultrasound transducer without causing upsizing.

Solution to Problem

[0008] To solve the above-described problem and achieve the object, an ultrasound endoscope according to the present invention includes an insertion portion to be inserted into a subject, and includes: an ultrasound functional unit provided at a distal end of the insertion portion, the ultrasound functional unit including an ultrasound transducer configured to transmit and receive an ultrasound wave on a surface including a longitudinal axis of the insertion portion, the surface being parallel to the longitudinal axis; and an endoscope functional unit connected to the ultrasound functional unit, the endoscope functional unit at least including: a balloon locking portion having a groove shape that can lock a balloon; and an imaging optical system, wherein a first plane passes, in a direction of the longitudinal axis of the insertion portion, through an end portion of the ultrasound transducer near the endoscope functional unit, the first plane being perpendicular to the longitudinal axis of the insertion portion, and the first plane is positioned closer to a proximal end than a second plane passing through an end portion of the endoscope functional unit near the ultrasound functional unit, the end portion of the endoscope functional unit being a boundary between the ultrasound functional unit and the endoscope functional unit.

[0009] Moreover, in the above-described ultrasound endoscope according to the present invention, the ultrasound functional unit is detachable from the endoscope functional unit.

[0010] Moreover, the above-described ultrasound endoscope according to the present invention further includes a rotation suppression unit configured to suppress rotation of the ultrasound functional unit around an axis that is parallel to the longitudinal axis, with respect to the endoscope functional unit.

[0011] Moreover, an ultrasound endoscope according to the present invention includes an insertion portion to be inserted into a subject, and includes: an ultrasound functional unit provided at a distal end of the insertion portion, the ultrasound functional unit including an ultrasound transducer configured to transmit and receive an ultrasound wave on a surface including a longitudinal axis of the insertion portion, and the surface being parallel to the longitudinal axis; an endoscope functional unit that at least includes an imaging optical system; and a balloon

locking portion configured to connect the ultrasound functional unit and the endoscope functional unit, the balloon locking portion having a groove shape that can lock a balloon, wherein a first plane passes, in a direction of the longitudinal axis of the insertion portion, through a first end portion of the ultrasound transducer near the endoscope functional unit, the first plane being perpendicular to the longitudinal axis of the insertion portion, and the first plane is positioned closer to a proximal end than a second plane passing through a second end portion of the balloon locking portion near the ultrasound functional unit.

[0012] Moreover, in the above-described ultrasound endoscope according to the present invention, a first distance in a direction of the longitudinal axis from a distal end of the longitudinal axis of the ultrasound functional unit to the second end portion is smaller than a second distance in the direction of the longitudinal axis between both end portions of the ultrasound functional unit.

[0013] Moreover, in the above-described ultrasound endoscope according to the present invention, relationships represented by following formulae (1) to (4) are satisfied:

$$m_2 = 2 \times R \sin (\theta_1/2) \dots (1);$$

$$m_3 = m_2 \cos \theta_2 \dots (2);$$

$$m_1 < m_3 \dots (3);$$

and

$$D_2 < m_4 < D_1 \dots (4),$$

where a distance in a direction of the longitudinal axis from a third end portion on a distal end side of the longitudinal axis of the ultrasound functional unit to the second end portion is denoted by m_1 , a distance between the first and third end portions is denoted by m_2 , a distance in the direction of the longitudinal axis between the first and third end portions is denoted by m_3 , a distance that is a largest distance in a direction perpendicular to the longitudinal axis from the third end portion to an end portion of the ultrasound transducer is denoted by m_4 , a curvature radius of a curved surface of the ultrasound transducer is denoted by R , an angle formed by the second and third end portions and a center of curvature of the curved surface of the ultrasound transducer is denoted by θ_1 , and an angle formed by a straight line being parallel to the longitudinal axis and a straight line passing through the second and third end portions is denoted by θ_2 .

Advantageous Effects of Invention

[0014] According to the present invention, such an effect that a curvature radius of an ultrasound transducer can be increased without causing upsizing is brought about.

Brief Description of Drawings

[0015]

FIG. 1 is a diagram schematically illustrating an endoscope system according to a first embodiment of the present invention.

FIG. 2 is a perspective view schematically illustrating a distal end configuration of an insertion portion of an ultrasound endoscope according to the first embodiment of the present invention.

FIG. 3 is a perspective view schematically illustrating a distal end configuration of the insertion portion of the ultrasound endoscope according to the first embodiment of the present invention.

FIG. 4 is a partially-enlarged view schematically illustrating a configuration of an ultrasound functional unit according to the first embodiment of the present invention.

FIG. 5 is a perspective view schematically illustrating a distal end configuration of the insertion portion of the ultrasound endoscope according to the first embodiment of the present invention.

FIG. 6 is a plan view schematically illustrating a configuration of the insertion portion of the ultrasound endoscope according to the first embodiment of the present invention that is viewed from a distal end side.

FIG. 7 is a perspective view schematically illustrating a distal end configuration of the insertion portion of the ultrasound endoscope according to the first embodiment of the present invention.

FIG. 8 is a perspective view schematically illustrating a distal end configuration of an insertion portion of an ultrasound endoscope according to a modified example of the first embodiment of the present invention.

FIG. 9 is a perspective view schematically illustrating a distal end configuration of an insertion portion of an ultrasound endoscope according to a second embodiment of the present invention.

FIG. 10 is a perspective view schematically illustrating a distal end configuration of the insertion portion of the ultrasound endoscope according to the second embodiment of the present invention.

FIG. 11 is a partially-enlarged view schematically illustrating a configuration of an ultrasound functional unit according to the second embodiment of the present invention.

FIG. 12 is a side view schematically illustrating a distal end configuration of the insertion portion of the

ultrasound endoscope according to the second embodiment of the present invention.

Description of Embodiments

[0016] A mode for carrying out the present invention (hereinafter, referred to as an embodiment) will be described below with reference to the drawings. In addition, the present invention is not limited by the embodiment to be described below. Furthermore, in the description of the drawings, the same parts are assigned the same signs.

(First Embodiment)

[0017] FIG. 1 is a diagram schematically illustrating an endoscope system according to a first embodiment of the present invention. An endoscope system 1 is a system for performing ultrasound diagnosis of the inside of a subject such as a human, using an ultrasound endoscope. As illustrated in FIG. 1, the endoscope system 1 includes an ultrasound endoscope 2, an ultrasound observation apparatus 3, an endoscope observation apparatus 4, a display device 5, and a light source device 6.

[0018] The ultrasound endoscope 2 converts an electrical pulse signal received from the ultrasound observation apparatus 3, into an ultrasound pulse (acoustic pulse), emits the ultrasound pulse onto a subject at its distal end portion, converts an ultrasound echo reflected by the subject, into an electrical echo signal represented by voltage change, and outputs the electrical echo signal.

[0019] The ultrasound endoscope 2 normally includes an imaging optical system and an image sensor, is inserted into a digestive tract (esophagus, stomach, duodenum, large intestine) or a respiratory organ (trachea, bronchus) of the subject, and can perform capturing of the digestive tract or the respiratory organ. In addition, their adjacent organs (pancreas, cholecystis, biliary duct, biliary tract, lymph nodes, mediastinum organ, blood vessels, etc.) can be captured using ultrasound waves. In addition, the ultrasound endoscope 2 includes a light guide that guides illumination light to be emitted onto a subject when optical capturing is performed. The light guide has a distal end portion and a proximal end portion. The distal end portion reaches a distal end of an insertion portion to be inserted into a subject of the ultrasound endoscope 2. On the other hand, the proximal end portion is connected to the light source device 6 that generates illumination light.

[0020] As illustrated in FIG. 1, the ultrasound endoscope 2 includes an insertion portion 21, an operating unit 22, a universal cord 23, and a connector 24. The insertion portion 21 is a portion to be inserted into the subject. As illustrated in FIG. 1, the insertion portion 21 includes a rigid distal end portion 211 that is provided on a distal end side, and holds a ultrasound transducer 7, a curve portion 212 capable of curving that is connected to a proximal end side of the distal end portion 211, and

a flexible tube portion 213 having flexibility that is connected to a proximal end side of the curve portion 212. Here, inside the insertion portion 21, a light guide for transferring illumination light supplied from the light source device 6, and a plurality of signal cables for transferring various signals are laid, and a processing tool insertion path for inserting a processing tool is formed, of which specific illustrations are omitted in the drawings. In addition, in this specification, the ultrasound transducer 7 side of the insertion portion 21 will be referred to as a distal end (also referred to as one end in a longitudinal axis N (refer to FIG. 4) direction of the insertion portion 21), and a side connecting to the operating unit 22 will be referred to as a proximal end (also referred to as another end in the longitudinal axis N direction of the insertion portion 21).

[0021] The ultrasound transducer 7 may be any of a convex transducer and a linear transducer. In this first embodiment, the description will be given assuming that the ultrasound endoscope 2 electrically performs scanning by providing, as the ultrasound transducer 7, a plurality of piezoelectric elements in an array, and electrically switching a piezoelectric element involved in transmission and reception, or delaying transmission and reception of each piezoelectric element. Nevertheless, the ultrasound endoscope 2 may mechanically scan the ultrasound transducer 7. A configuration of the ultrasound transducer 7 will be described later.

[0022] FIG. 2 is a perspective view schematically illustrating a distal end configuration of the insertion portion of the ultrasound endoscope according to this first embodiment. FIG. 3 is a perspective view schematically illustrating a distal end configuration of the insertion portion of the ultrasound endoscope according to this first embodiment, and is a perspective view of the distal end configuration of the insertion portion that is viewed from an opposite direction to FIG. 2. As illustrated in FIG. 2, the distal end portion 211 includes an ultrasound functional unit 214 that holds the ultrasound transducer 7, and an endoscope functional unit 215 including an observation window 215a that causes light to enter an imaging optical system that includes an objective lens and the like, and takes in light from the outside, and an illumination window 215b being a part of an illumination optical system that collects illumination light and emits the illumination light to the outside. In the endoscope functional unit 215, a processing tool protrusion port 215c that is communicated with the processing tool insertion path formed in the insertion portion 21, and causes a processing tool to protrude from the distal end of the insertion portion 21 is formed. The endoscope functional unit 215 detachably connects with the ultrasound functional unit 214 at one end, and connects to the curve portion 212 at another end. The processing tool insertion path is provided so that an end vicinity connecting to the processing tool protrusion port 215c inclines with respect to the longitudinal axis N of the insertion portion 21, and the processing tool protrudes from the processing tool

protrusion port 215c in a direction inclining with respect to the longitudinal axis N. The longitudinal axis N here refers to an axis extending along the longitudinal direction of the insertion portion 21. In the curve portion 212 and the flexible tube portion 213, an axis direction varies depending on each position. Nevertheless, in the rigid distal end portion 211, the longitudinal axis N is an axis forming a fixed straight line.

[0023] The operating unit 22 is a portion that is connected to a proximal end side of the insertion portion 21, and receives various operations from a doctor or the like. As illustrated in FIG. 1, the operating unit 22 includes a curve knob 221 for performing a curving operation of the curve portion 212, and a plurality of operating members 222 for performing various operations. In addition, a processing tool insertion port 223 that is communicated with the processing tool insertion path, and is provided for inserting the processing tool into the processing tool insertion path is formed in the operating unit 22.

[0024] The universal cord 23 is a cable extending from the operating unit 22, and in which a plurality of signal cables for transferring various signals, optical fibers for transferring illumination light supplied from the light source device 6, and the like are laid.

[0025] The connector 24 is provided at a distal end of the universal cord 23. In addition, the connector 24 includes first to third connector portions 241 to 243 to which an ultrasound cable 31, a video cable 41, and an optical fiber cable 61 are respectively connected.

[0026] The ultrasound observation apparatus 3 electrically-connects to the ultrasound endoscope 2 via the ultrasound cable 31 (FIG. 1), outputs a pulse signal to the ultrasound endoscope 2 via the ultrasound cable 31, and inputs an echo signal from the ultrasound endoscope 2. Then, the ultrasound observation apparatus 3 performs predetermined processing on the echo signal to generate an ultrasound image.

[0027] The endoscope observation apparatus 4 electrically-connects to the ultrasound endoscope 2 via the video cable 41 (FIG. 1), and inputs an image signal from the ultrasound endoscope 2 via the video cable 41. Then, the endoscope observation apparatus 4 performs predetermined processing on the image signal to generate an endoscope image.

[0028] The display device 5 is formed by using a liquid crystal, an organic electro luminescence (EL), a projector, a cathode ray tube (CRT), or the like, and displays the ultrasound image generated in the ultrasound observation apparatus 3, the endoscope image generated in the endoscope observation apparatus 4, and the like.

[0029] The light source device 6 connects to the ultrasound endoscope 2 via the optical fiber cable 61 (FIG. 1), and supplies, via the optical fiber cable 61, illumination light for illuminating the inside of a subject, to the ultrasound endoscope 2.

[0030] Subsequently, a configuration of the ultrasound transducer 7 provided at the distal end of the insertion portion 21 will be described with reference to FIGS. 2 to

4. FIG. 4 is a partially-enlarged view schematically illustrating a configuration of the ultrasound functional unit according to this first embodiment, and is a partially-enlarged view in which a plane passing through the longitudinal axis of the insertion portion 21 is assumed to be a cutting plane. In this first embodiment, the description will be given assuming that the ultrasound transducer 7 is a convex-type ultrasound transducer as illustrated in FIG. 2, and is a one-dimensional array (1D array) having a piezoelectric element group 71 in which a plurality of piezoelectric elements is arrayed in a line. In other words, in the ultrasound transducer 7 according to this first embodiment, the plurality of piezoelectric elements 71 is arranged along an outer surface forming a curved surface of the ultrasound transducer 7, and transmits and receives ultrasound waves on a surface including the longitudinal axis N and being parallel to the longitudinal axis N.

[0031] The ultrasound transducer 7 includes the piezoelectric element group 71 having a prismatic shape, and including a plurality of piezoelectric elements arranged with a uniform longitudinal direction, an acoustic matching layer 72 each provided on the outer surface side of the ultrasound transducer 7 for the piezoelectric element group 71, an acoustic lens 73 provided on an opposite side to the side of the acoustic matching layer 72 that is in contact with the piezoelectric element group 71, a relay board 74 that electrically connects each piezoelectric element of the piezoelectric element group 71, and a cable into which the insertion portion 21 is inserted, and a backing material (not illustrated) provided on an opposite side to a side of the piezoelectric element group 71 that is in contact with the acoustic matching layer 72 (refer to FIG. 4). The backing material fills a hollow space formed between the acoustic matching layer 72 and a wall portion having a cup shape and accommodating the relay board 74. A cable 74a into which the insertion portion 21 is to be inserted is connected to the relay board 74.

[0032] The piezoelectric element converts an electrical pulse signal into an ultrasound pulse (acoustic pulse), emits the ultrasound pulse onto a subject, converts an ultrasound echo reflected by the subject, into an electrical echo signal represented by a voltage change, and outputs the electrical echo signal.

[0033] The acoustic matching layer 72 matches acoustic impedance between a piezoelectric element and an observation target for efficiently transmitting sound (ultrasound waves) between the piezoelectric element group 71 and the observation target. The acoustic matching layer 72 may be formed of a plurality of layers made of materials different from each other, or may be one layer depending on the properties of the piezoelectric element and the observation target.

[0034] The acoustic lens 73 covers the acoustic matching layer 72 and the outer surface of the wall portion. The acoustic lens 73 constitutes a part of the outer surface of the ultrasound transducer 7. The acoustic lens 73 is formed by using silicone, polymethylpentene, epoxy res-

in, polyetherimide, and the like. One surface of the acoustic lens 73 has a convex shape or a concave shape so as to have a function of stopping down ultrasound waves. The acoustic lens 73 emits ultrasound waves having passed through the acoustic matching layer 72, to the outside, or takes in an ultrasound echo from the outside. The acoustic lens 73 can be arbitrarily provided, and a configuration not including the acoustic lens 73 may be employed.

[0035] The backing material attenuates unnecessary ultrasound vibration generated by an operation of the piezoelectric element. The backing material is formed by using material having a large attenuation rate, such as, for example, epoxy resin in which fillers such as alumina and zirconia are dispersed, or rubber in which the aforementioned fillers are dispersed.

[0036] As mentioned above, the ultrasound functional unit 214 detachably connects with the endoscope functional unit 215. More particularly, the ultrasound functional unit 214 includes a main body portion 214a that holds the ultrasound transducer 7, and a protrusion portion 214b that protrudes from the main body portion 214a, and connects with the endoscope functional unit 215. In contrast to this, the endoscope functional unit 215 includes a hole portion 215d that is provided at an end portion on the opposite side to a side connecting with the curve portion 212, and is a hole connecting with the ultrasound functional unit 214, and a balloon locking portion 215e having a groove shape that can lock a balloon (not illustrated). The ultrasound functional unit 214 and the endoscope functional unit 215 connect to each other by the protrusion portion 214b fitting into the hole portion 215d. At this time, both units may be fixed by a known method such as adhesive agent and screwing.

[0037] The ultrasound transducer 7 having the above configuration emits ultrasound waves onto an observation target via the acoustic matching layer 72 and the acoustic lens 73 by each piezoelectric element vibrating according to an input of a pulse signal. At this time, in the piezoelectric elements, on an opposite side to an arrangement side of the acoustic matching layer 72 and the acoustic lens 73, due to the backing material, vibration of the piezoelectric elements is attenuated, and the vibration of the piezoelectric elements is not transmitted. In addition, ultrasound waves reflected by the observation target are transmitted to each piezoelectric element via the acoustic matching layer 72 and the acoustic lens 73. The piezoelectric element vibrates according to the transmitted ultrasound waves, and the piezoelectric element converts the vibration into an electrical echo signal, and outputs, as an echo signal, the electrical echo signal to the ultrasound observation apparatus 3 via a cable (not illustrated).

[0038] Subsequently, the arrangement of the ultrasound transducer 7 in the ultrasound functional unit 214 will be described with reference to FIG. 4. As illustrated in FIG. 4, a plane P_1 (first plane) passes, in the longitudinal axis N direction of the insertion portion 21, through

an end portion of the ultrasound transducer 7 near the endoscope functional unit 215 and is perpendicular to the longitudinal axis N of the insertion portion 21. The plane P_1 is positioned closer to a proximal end than a plane P_2 (second plane) passing through an end portion of the hole portion 215d near the ultrasound functional unit 214, the end portion being an end portion of the endoscope functional unit 215 and being a boundary between the ultrasound functional unit 214 and the endoscope functional unit 215.

[0039] For example, in the case of increasing a curvature radius of a curved surface of the ultrasound transducer 7 (curved surface passing through distal ends of a plurality of piezoelectric elements) without changing the size and the number of piezoelectric elements, even if the ultrasound transducer 7 upsizes, if an end portion on the proximal end side of the ultrasound transducer 7 is extended toward the proximal end side in the longitudinal axis N direction of the insertion portion 21 so as to satisfy a positional relationship with the plane P_1 and the plane P_2 , without elongating an end portion on the distal end side of the ultrasound transducer 7, even if the ultrasound transducer 7 upsizes, the insertion portion 21 can be formed without elongating an extension length in the longitudinal axis direction of the insertion portion 21.

[0040] FIG. 5 is a perspective view schematically illustrating a distal end configuration of the insertion portion of the ultrasound endoscope according to this first embodiment. As illustrated in FIG. 5, the outer surface of the ultrasound transducer 7 does not interfere with an axis L_1 extending in an extending direction of the processing tool protruding from the processing tool protrusion port 215c. Thus, if the ultrasound transducer 7 satisfies the aforementioned positional relationship with the plane P_1 and the plane P_2 , the ultrasound transducer 7 does not interfere with an operation of the processing tool protruding from the processing tool protrusion port 215c.

[0041] FIG. 6 is a plan view schematically illustrating a configuration of the insertion portion of the ultrasound endoscope according to this first embodiment that is viewed from a distal end side. As illustrated in FIG. 6, an axis L_2 passing through the center of the ultrasound transducer 7 in a direction perpendicular to the longitudinal axis direction of the insertion portion 21, and being parallel to the longitudinal axis direction of the insertion portion 21 is offset with respect to an axis L_3 passing through the center of the observation window 215a, and being parallel to the longitudinal axis direction of the insertion portion 21. Thus, for example, even if the outer surface of the acoustic lens 73 forms a convex shape along a direction perpendicular to the longitudinal axis direction of the insertion portion 21, the ultrasound transducer 7 does not interfere with light entering the observation window 215a.

[0042] FIG. 7 is a perspective view schematically illustrating a distal end configuration of the insertion portion of the ultrasound endoscope according to this first embodiment. As illustrated in FIG. 7, the outer surface of

the ultrasound transducer 7 does not interfere with an optical axis L_4 (imaging optical axis of imaging optical system) of light entering the observation window 215a, and an optical axis L_5 of illumination light emitted by the illumination window 215b constituting a part of the illumination optical system. Thus, if the ultrasound transducer 7 satisfies the aforementioned positional relationship with the plane P_1 and the plane P_2 , the ultrasound transducer 7 does not interfere with observation light entering the imaging optical system, and illumination light emitted from the illumination window 215b.

[0043] According to this first embodiment described above, in the longitudinal axis direction of the insertion portion 21, the plane P_1 passing through an end portion on the endoscope functional unit 215 side of the ultrasound transducer 7, and being perpendicular to the longitudinal axis of the insertion portion 21 is positioned on the proximal end side of the plane P_2 passing through an end portion of the endoscope functional unit 215 that serves as a boundary between the ultrasound functional unit 214 and the endoscope functional unit 215, and is an end portion on the ultrasound functional unit 214 side of the hole portion 215d. Thus, a curvature radius of the ultrasound transducer 7 can be increased without elongating an extension length of the ultrasound transducer 7, and without causing upsizing.

[0044] In addition, in the aforementioned first embodiment, the description has been given using the 1D array as an example. Alternatively, a 1.25D array, 1.5D array, 1.75D array, and the like, in which a plurality of piezoelectric elements (vibration portions) is arrayed in a direction (elevation direction) substantially-perpendicular to a scanning direction of the ultrasound transducer (an array direction of the piezoelectric elements in the 1D array), can also be applied. In addition, in this first embodiment, 1.25D, 1.5D, and 1.75D that are divided in the elevation direction, and acquire one ultrasound image in the scanning direction are included assuming that a plurality of piezoelectric elements is one-dimensionally arrayed.

[0045] In addition, in the aforementioned first embodiment, the description has been given assuming that the ultrasound functional unit 214 and the endoscope functional unit 215 are separate units. Nevertheless, if the aforementioned positional relationship with the plane P_1 and the plane P_2 is satisfied, the units may be integrally provided.

(Modified Example of First Embodiment)

[0046] FIG. 8 is a perspective view schematically illustrating a distal end configuration of an insertion portion of an ultrasound endoscope according to a modified example of this first embodiment. In this modified example, the main body portion 214a according to the aforementioned first embodiment is provided with a projection portion 214c, and a recessed portion 215f is provided on an outer circumferential surface of the hole portion 215d.

[0047] More particularly, the projection portion 214c is

provided at an end portion of the main body portion 214a on a side connecting with the endoscope functional unit 215. In addition, the recessed portion 215f is provided on a surface that is the outer circumferential surface of the hole portion 215d, and is in contact with the ultrasound functional unit 214, according to a formation position of the projection portion 214c. The projection portion 214c can fit into the recessed portion 215f, and at least a side surface in a direction rotating around the longitudinal axis of the insertion portion 21 fits therewith with being in contact with a wall surface of the recessed portion 215f.

[0048] According to this modified example, the main body portion 214a is provided with the projection portion 214c, and the recessed portion 215f is provided on the outer circumferential surface of the hole portion 215d, and the projection portion 214c fits into with being in contact with the wall surface of the recessed portion 215f, at least on the side surface in the direction rotating around the axis N being parallel to the longitudinal axis of the insertion portion 21. Thus, the ultrasound functional unit 214 and the endoscope functional unit 215 can be relatively positioned, and the ultrasound functional unit 214 can suppress the rotation around the longitudinal axis of the insertion portion 21.

(Second Embodiment)

[0049] FIG. 9 is a perspective view schematically illustrating a distal end configuration of an insertion portion of an ultrasound endoscope according to a second embodiment of the present invention. FIG. 10 is a perspective view schematically illustrating a distal end configuration of the insertion portion of the ultrasound endoscope according to this second embodiment, and is a perspective view of a distal end configuration of the insertion portion that is viewed from an opposite direction to FIG. 9. In the aforementioned first embodiment, the description has been given assuming that, in the distal end portion 211, the ultrasound functional unit 214 and the endoscope functional unit 215 are provided as separate units. Nevertheless, in a distal end portion 216 according to this second embodiment, an ultrasound functional unit 216a and an endoscope functional unit 216b are integrally provided.

[0050] As illustrated in FIG. 9, the distal end portion 216 includes the ultrasound functional unit 216a that holds the ultrasound transducer 7, the endoscope functional unit 216b including an observation window 216ba that causes light to enter an imaging optical system that includes an objective lens and the like, and takes in light from the outside, and an illumination window 216bb constituting a part of an illumination optical system that collects illumination light and emits the light to the outside, and a balloon locking portion 216c that is provided between the ultrasound functional unit 216a and the endoscope functional unit 216b to connect the ultrasound functional unit 216a and the endoscope functional unit

216b, and has a groove shape for locking a balloon. In the endoscope functional unit 216b, a processing tool protrusion port 216bc that is communicated with the processing tool insertion path formed in the insertion portion 21, and causes a processing tool to protrude from the distal end of the insertion portion 21 is formed. The endoscope functional unit 216b connects to the ultrasound functional unit 216a at one end, and connects to the curve portion 212 at another end.

[0051] Subsequently, the arrangement of the ultrasound transducer 7 in the ultrasound functional unit 216a will be described with reference to FIG. 11. FIG. 11 is a partially-enlarged view schematically illustrating a configuration of the ultrasound functional unit according to this second embodiment, and is a partially-enlarged view in which a plane passing through the longitudinal axis N of the insertion portion 21 is assumed to be a cutting plane. As illustrated in FIG. 11, in the longitudinal axis N direction of the insertion portion 21, a plane P₃ (first plane) passing through an end portion (first end portion) on the endoscope functional unit 216b side of the ultrasound transducer 7, and being perpendicular to the longitudinal axis N of the insertion portion 21 is positioned on a proximal end side of a plane P₄ (second plane) passing through an end portion (second end portion) on the ultrasound functional unit 216a side of the balloon locking portion 216c.

[0052] For example, in the case of increasing a curvature radius of a curved surface of the ultrasound transducer 7 (curved surface passing through distal ends of a plurality of piezoelectric elements) without changing the size and the number of piezoelectric elements, if an end portion on the proximal end side of the ultrasound transducer 7 is extended toward the proximal end side of the insertion portion 21 so as to satisfy a positional relationship with the plane P₃ and the plane P₄, without elongating an end portion on the distal end side of the ultrasound transducer 7, even if the ultrasound transducer 7 upsizes, the insertion portion 21 can be formed without elongating an extension length in the longitudinal axis direction of the insertion portion 21.

[0053] FIG. 12 is a side view schematically illustrating a distal end configuration of the insertion portion of the ultrasound endoscope according to this second embodiment, and is a diagram illustrating a relationship between lengths of portions in the distal end portion 216. When a largest diameter of the endoscope functional unit 216b is denoted by D₁, a smallest diameter of the endoscope functional unit 216b is denoted by D₂, an end portion (third end portion) on a distal end side in an array direction of the piezoelectric elements of the ultrasound transducer 7 is denoted by Q₁, an end portion (first end portion) on a proximal end side is denoted by Q₂, a distance that is from the end portion Q₁ to an end portion (second end portion) on the ultrasound functional unit 216a side of the balloon locking portion 216c, and is a distance (first distance) in the longitudinal axis direction of the insertion portion 21 is denoted by m₁, a distance between the end

portions Q₁ and Q₂ is denoted by m₂, a distance (second distance) in the longitudinal axis direction of the insertion portion 21 between the end portions Q₁ and Q₂ is denoted by m₃, a distance that is from the end portion Q₁ to the end portion of the ultrasound transducer 7, and is the largest distance in a direction perpendicular to the longitudinal axis N direction of the insertion portion 21 is denoted by m₄, a curvature radius of the curved surface of the ultrasound transducer 7 (curved surface passing through distal ends of a plurality of piezoelectric elements) is denoted by R, an angle formed by the end portions Q₁ and Q₂, and the center of curvature of the curved surface of the ultrasound transducer 7 is denoted by θ₁, and an angle formed by a straight line being parallel to the longitudinal axis direction of the insertion portion 21, and a straight line passing through the end portions Q₁ and Q₂ is denoted by θ₂, relationships represented by the following formulae (1) to (4) are satisfied.

$$m_2 = 2 \times R \sin (\theta_1/2) \dots (1)$$

$$m_3 = m_2 \cos \theta_2 \dots (2)$$

$$m_1 < m_3 \dots (3)$$

$$D_2 < m_4 < D_1 \dots (4)$$

[0054] In addition, as in the aforementioned first embodiment, the outer surface of the ultrasound transducer 7 is provided so as not to interfere with the axis (axis L₁) extending in an extending direction of the processing tool protruding from the processing tool protrusion port 216bc. Thus, if the ultrasound transducer 7 satisfies the aforementioned positional relationship with the plane P₃ and the plane P₄, the ultrasound transducer 7 does not interfere with an operation of the processing tool protruding from the processing tool protrusion port 216c.

[0055] In addition, the axis (axis L₂) passing through the center of the ultrasound transducer 7 in a direction perpendicular to the longitudinal axis direction of the insertion portion 21, and being parallel to the longitudinal axis direction of the insertion portion 21 is provided to be offset with respect to the axis (axis L₃) passing through the center of the observation window 216ba, and being parallel to the longitudinal axis direction of the insertion portion 21. Thus, for example, even if the outer surface of the acoustic lens 73 forms a convex shape along a direction perpendicular to the longitudinal axis direction of the insertion portion 21, the ultrasound transducer 7 does not interfere with light entering the observation window 216ba.

[0056] In addition, the outer surface of the ultrasound transducer 7 does not interfere with the optical axis (op-

tical axis L_4) of light entering the observation window 216ba, and the optical axis (optical axis L_5) of illumination light emitted by the illumination window 216bb constituting a part of the illumination optical system. Thus, if the ultrasound transducer 7 satisfies the aforementioned positional relationship with the plane P_3 and the plane P_4 , the ultrasound transducer 7 does not interfere with observation light entering the observation optical system, and illumination light emitted from the illumination window 216bb.

[0057] According to this second embodiment described above, the plane P_3 passes, in the longitudinal axis direction of the insertion portion 21, through an end portion near the endoscope functional unit 216b of the ultrasound transducer 7 and is perpendicular to the longitudinal axis of the insertion portion 21. The plane P_3 is positioned closer to the proximal end than the plane P_4 passing through an end portion of the balloon locking portion 216c near the ultrasound functional unit 216a. Thus, a curvature radius of the ultrasound transducer 7 can be increased without elongating an extension length of the ultrasound transducer 7, and without causing up-sizing.

[0058] Modes for carrying out the present invention have been described so far. Nevertheless, the present invention is not to be limited only by the aforementioned embodiments and modified example. The present invention is not limited to the above-described embodiments and modified example, and can include various embodiments without departing from the technical ideas described in the claims. In addition, the configurations in the embodiments and the modified example may be appropriately combined.

[0059] In addition, an ultrasound miniature probe not having an optical system and having a thin diameter may be applied as the ultrasound endoscope. The ultrasound miniature probe is normally inserted into a biliary tract, biliary duct, pancreas duct, trachea, bronchus, urethra, or ureter, and is used when their adjacent organs (pancreas, lung, glandula prostatica, urinary bladder, lymph nodes, etc.) are observed.

[0060] In addition, an external ultrasound probe that emits ultrasound waves from a body surface of a subject may be applied as an ultrasound endoscope. The external ultrasound probe is normally used when abdominal organs (liver, cholecystis, urinary bladder), breast (in particular, glandula mammaria), and glandula thyreoidea are observed.

Industrial Applicability

[0061] As described above, an ultrasound endoscope according to the present invention is useful in increasing a curvature radius of an ultrasound transducer without causing up-sizing.

Reference Signs List

[0062]

- 5 1 ENDOSCOPE SYSTEM
- 2 ULTRASOUND ENDOSCOPE
- 3 ULTRASOUND OBSERVATION APPARATUS
- 4 ENDOSCOPE OBSERVATION APPARATUS
- 10 5 DISPLAY DEVICE
- 6 LIGHT SOURCE DEVICE
- 7 ULTRASOUND TRANSDUCER
- 21 INSERTION PORTION
- 15 22 OPERATING UNIT
- 23 UNIVERSAL CORD
- 24 CONNECTOR
- 31 ULTRASOUND CABLE
- 41 VIDEO CABLE
- 20 61 OPTICAL FIBER CABLE
- 71 PIEZOELECTRIC ELEMENT GROUP
- 72 ACOUSTIC MATCHING LAYER
- 73 ACOUSTIC LENS
- 74 RELAY BOARD
- 25 211, 212 216 DISTAL END PORTION
- 213 CURVE PORTION
- 214, 214a FLEXIBLE TUBE PORTION
- 30 214a 216a ULTRASOUND FUNCTIONAL UNIT
- 214b MAIN BODY PORTION
- 214c PROTRUSION PORTION
- 215, 216b PROJECTION PORTION
- 215a, 216ba ENDOSCOPE FUNCTIONAL UNIT
- 35 215b, 216bb OBSERVATION WINDOW
- 215c, 216bc ILLUMINATION WINDOW
- 215d PROCESSING TOOL PROTRUSION PORT
- 215e, 216c HOLE PORTION
- 40 215f BALLOON LOCKING PORTION
- 221 RECESSED PORTION
- 222 CURVE KNOB
- 223 OPERATING MEMBER
- 45 241 PROCESSING TOOL INSERTION PORT
- 242 FIRST CONNECTOR PORTION
- 243 SECOND CONNECTOR PORTION
- THIRD CONNECTOR PORTION

50 **Claims**

- 1. An ultrasound endoscope including an insertion portion to be inserted into a subject, the ultrasound endoscope comprising:

55

an ultrasound functional unit provided at a distal end of the insertion portion, the ultrasound functional unit including an ultrasound transducer

configured to transmit and receive an ultrasound wave on a surface including a longitudinal axis of the insertion portion, the surface being parallel to the longitudinal axis; and

an endoscope functional unit connected to the ultrasound functional unit, the endoscope functional unit at least including: a balloon locking portion having a groove shape that can lock a balloon; and an imaging optical system, wherein a first plane passes, in a direction of the longitudinal axis of the insertion portion, through an end portion of the ultrasound transducer near the endoscope functional unit, the first plane being perpendicular to the longitudinal axis of the insertion portion, and

the first plane is positioned closer to a proximal end than a second plane passing through an end portion of the endoscope functional unit near the ultrasound functional unit, the end portion of the endoscope functional unit being a boundary between the ultrasound functional unit and the endoscope functional unit.

2. The ultrasound endoscope according to claim 1, wherein the ultrasound functional unit is detachable from the endoscope functional unit.

3. The ultrasound endoscope according to claim 1 or 2, further comprising a rotation suppression unit configured to suppress rotation of the ultrasound functional unit around an axis that is parallel to the longitudinal axis, with respect to the endoscope functional unit.

4. An ultrasound endoscope including an insertion portion to be inserted into a subject, the ultrasound endoscope comprising:

an ultrasound functional unit provided at a distal end of the insertion portion, the ultrasound functional unit including an ultrasound transducer configured to transmit and receive an ultrasound wave on a surface including a longitudinal axis of the insertion portion, and the surface being parallel to the longitudinal axis;

an endoscope functional unit that at least includes an imaging optical system; and a balloon locking portion configured to connect the ultrasound functional unit and the endoscope functional unit, the balloon locking portion having a groove shape that can lock a balloon, wherein a first plane passes, in a direction of the longitudinal axis of the insertion portion, through a first end portion of the ultrasound transducer near the endoscope functional unit, the first plane being perpendicular to the longitudinal axis of the insertion portion, and the first plane is positioned closer to a proximal

end than a second plane passing through a second end portion of the balloon locking portion near the ultrasound functional unit.

5. The ultrasound endoscope according to claim 4, wherein a first distance in a direction of the longitudinal axis from a distal end of the longitudinal axis of the ultrasound functional unit to the second end portion is smaller than a second distance in the direction of the longitudinal axis between both end portions of the ultrasound functional unit.

6. The ultrasound endoscope according to claim 4, relationships represented by following formulae (1) to (4) are satisfied:

$$m_2 = 2 \times R \sin (\theta_1/2) \dots (1);$$

$$m_3 = m_2 \cos \theta_2 \dots (2);$$

$$m_1 < m_3 \dots (3);$$

and

$$D_2 < m_4 < D_1 \dots (4),$$

where a distance in a direction of the longitudinal axis from a third end portion on a distal end side of the longitudinal axis of the ultrasound functional unit to the second end portion is denoted by m_1 , a distance between the first and third end portions is denoted by m_2 , a distance in the direction of the longitudinal axis between the first and third end portions is denoted by m_3 , a distance that is a largest distance in a direction perpendicular to the longitudinal axis from the third end portion to an end portion of the ultrasound transducer is denoted by m_4 , a curvature radius of a curved surface of the ultrasound transducer is denoted by R , an angle formed by the second and third end portions and a center of curvature of the curved surface of the ultrasound transducer is denoted by θ_1 , and an angle formed by a straight line being parallel to the longitudinal axis and a straight line passing through the second and third end portions is denoted by θ_2 .

FIG.2

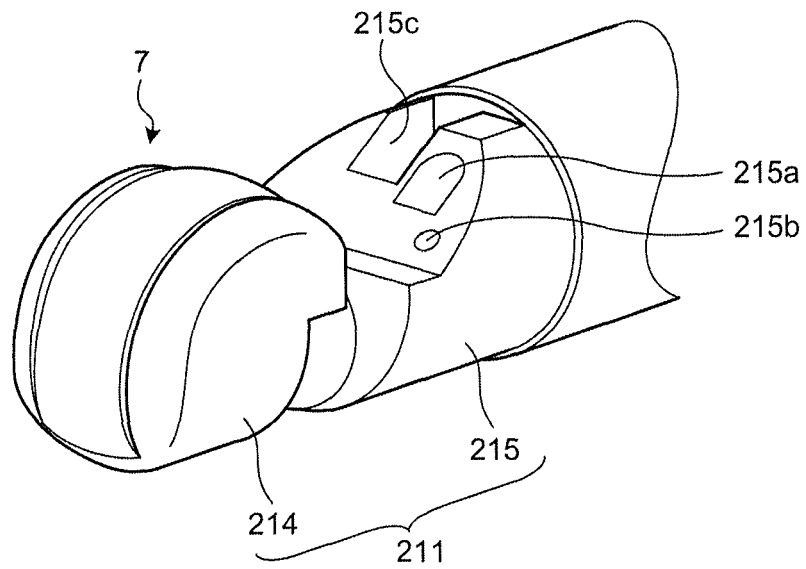

FIG.3

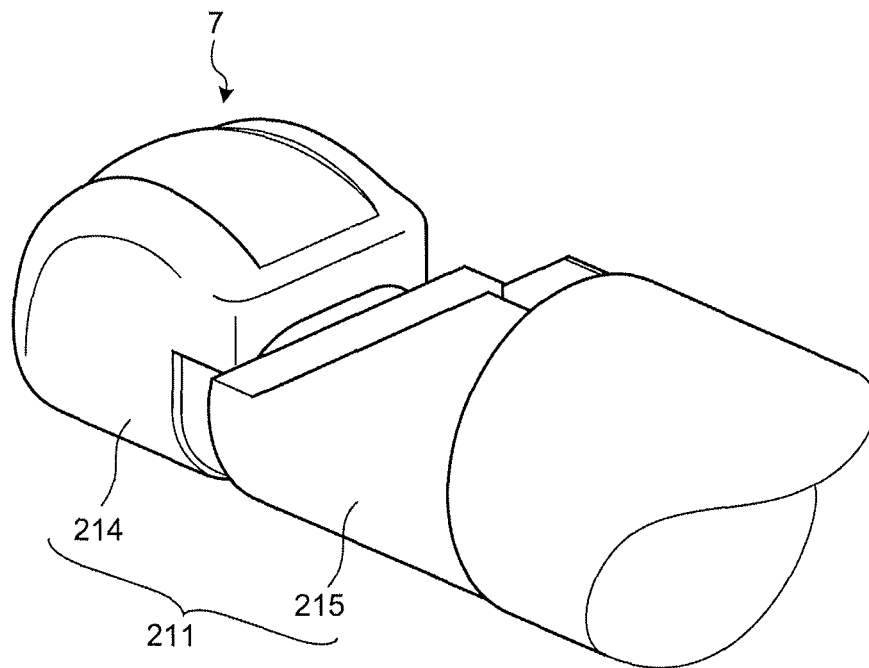

FIG.4

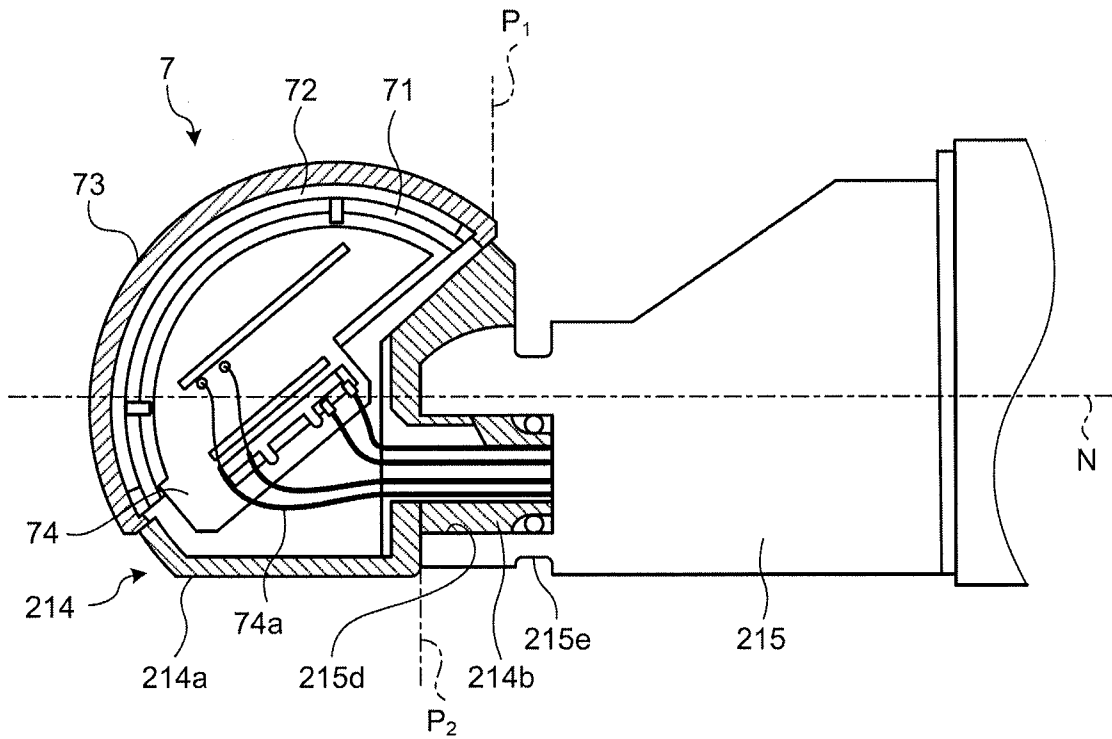

FIG.5

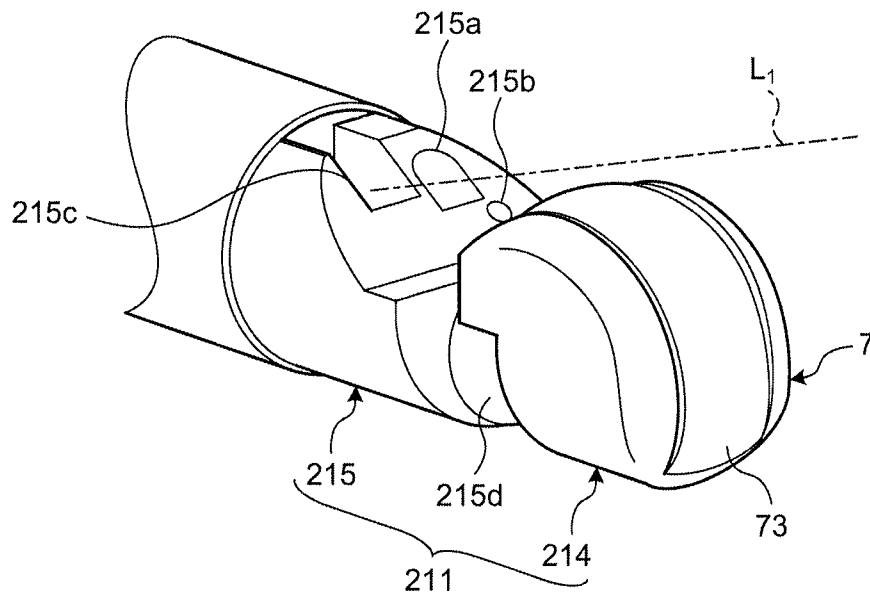

FIG.8

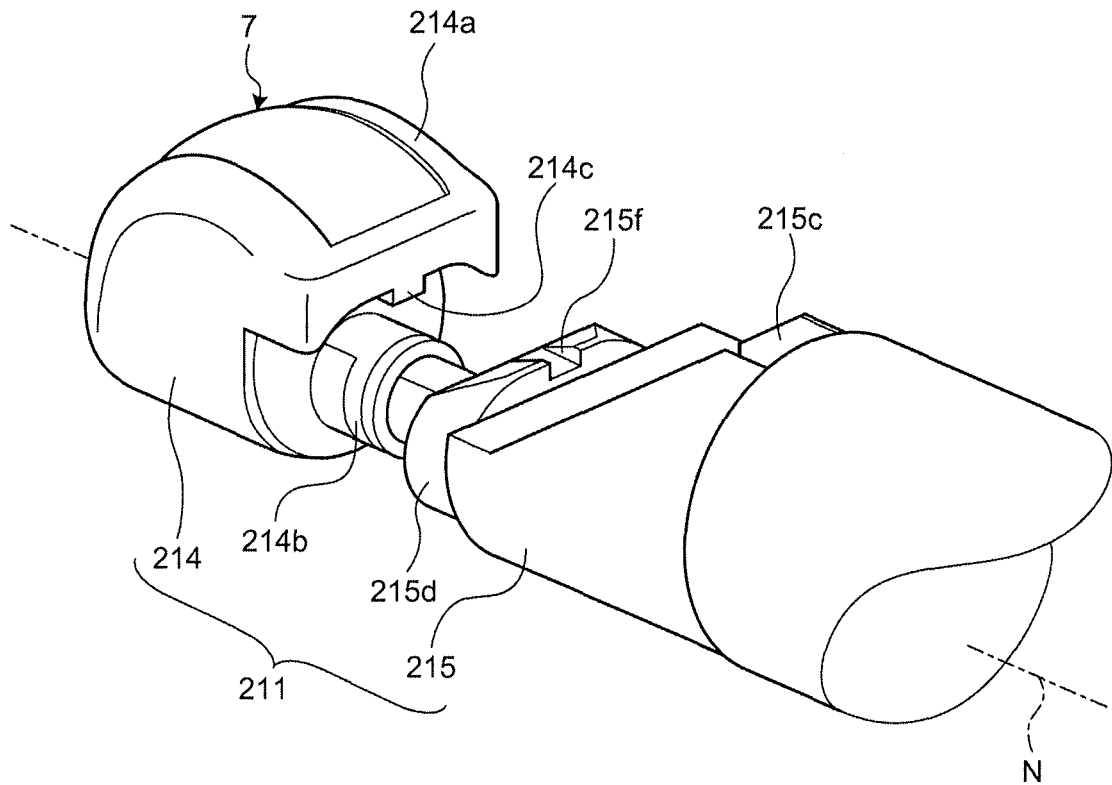

FIG.9

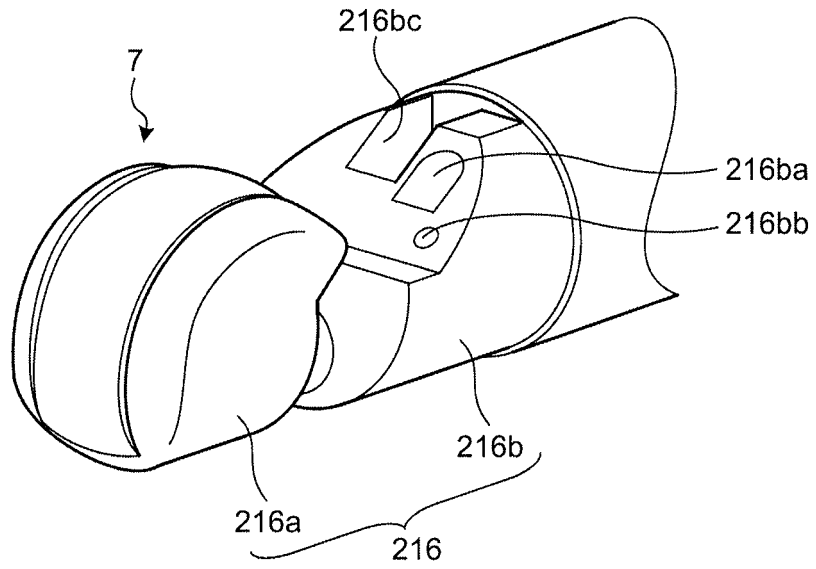
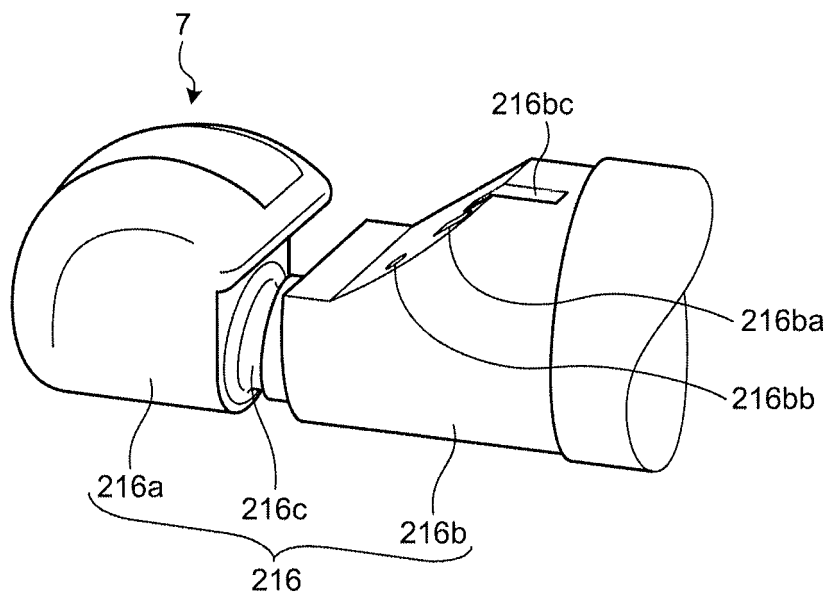

FIG.10



INTERNATIONAL SEARCH REPORT

International application No.

PCT/JP2016/060836

A. CLASSIFICATION OF SUBJECT MATTER

A61B8/12(2006.01) i

According to International Patent Classification (IPC) or to both national classification and IPC

B. FIELDS SEARCHED

Minimum documentation searched (classification system followed by classification symbols)

A61B8/00-8/15

Documentation searched other than minimum documentation to the extent that such documents are included in the fields searched

Jitsuyo Shinan Koho	1922-1996	Jitsuyo Shinan Toroku Koho	1996-2016
Kokai Jitsuyo Shinan Koho	1971-2016	Toroku Jitsuyo Shinan Koho	1994-2016

Electronic data base consulted during the international search (name of data base and, where practicable, search terms used)

C. DOCUMENTS CONSIDERED TO BE RELEVANT

Category*	Citation of document, with indication, where appropriate, of the relevant passages	Relevant to claim No.
Y A	JP 2013-27695 A (Olympus Medical Systems Corp.), 07 February 2013 (07.02.2013), paragraphs [0010] to [0072]; fig. 1 to 8 (Family: none)	1-3 4-6
Y	JP 2012-245061 A (Olympus Medical Systems Corp.), 13 December 2012 (13.12.2012), paragraphs [0011] to [0045]; fig. 1 to 3 (Family: none)	1-3
Y	JP 2011-206416 A (Fujifilm Corp.), 20 October 2011 (20.10.2011), paragraphs [0020] to [0035]; fig. 1 to 4 (Family: none)	1-3

 Further documents are listed in the continuation of Box C.
 See patent family annex.

* Special categories of cited documents:

"A" document defining the general state of the art which is not considered to be of particular relevance

"E" earlier application or patent but published on or after the international filing date

"L" document which may throw doubts on priority claim(s) or which is cited to establish the publication date of another citation or other special reason (as specified)

"O" document referring to an oral disclosure, use, exhibition or other means

"P" document published prior to the international filing date but later than the priority date claimed

"T" later document published after the international filing date or priority date and not in conflict with the application but cited to understand the principle or theory underlying the invention

"X" document of particular relevance; the claimed invention cannot be considered novel or cannot be considered to involve an inventive step when the document is taken alone

"Y" document of particular relevance; the claimed invention cannot be considered to involve an inventive step when the document is combined with one or more other such documents, such combination being obvious to a person skilled in the art

"&" document member of the same patent family

Date of the actual completion of the international search
15 June 2016 (15.06.16)Date of mailing of the international search report
28 June 2016 (28.06.16)Name and mailing address of the ISA/
Japan Patent Office
3-4-3, Kasumigaseki, Chiyoda-ku,
Tokyo 100-8915, Japan

Authorized officer

Telephone No.

Form PCT/ISA/210 (second sheet) (January 2015)

INTERNATIONAL SEARCH REPORT

International application No.
PCT/JP2016/060836

C (Continuation). DOCUMENTS CONSIDERED TO BE RELEVANT

5
10
15
20
25
30
35
40
45
50
55

Category*	Citation of document, with indication, where appropriate, of the relevant passages	Relevant to claim No.
A	WO 1992/18054 A1 (INTERSPEC, INC.), 29 October 1992 (29.10.1992), page 3, line 11 to page 9, line 31; fig. 1 & US 5191890 A	1-6
A	JP 62-227334 A (Toshiba Corp.), 06 October 1987 (06.10.1987), page 2, lower right column, line 6 to page 3, upper right column, line 15; fig. 2 (Family: none)	1-6

REFERENCES CITED IN THE DESCRIPTION

This list of references cited by the applicant is for the reader's convenience only. It does not form part of the European patent document. Even though great care has been taken in compiling the references, errors or omissions cannot be excluded and the EPO disclaims all liability in this regard.

Patent documents cited in the description

- JP 2004254942 A [0005]

专利名称(译)	超声波内窥镜		
公开(公告)号	EP3315077A1	公开(公告)日	2018-05-02
申请号	EP2016814021	申请日	2016-03-31
[标]申请(专利权)人(译)	奥林巴斯株式会社		
申请(专利权)人(译)	OLYMPUS CORPORATION		
当前申请(专利权)人(译)	OLYMPUS CORPORATION		
[标]发明人	KITAHARA TOSHIHIRO		
发明人	KITAHARA, TOSHIHIRO		
IPC分类号	A61B8/12		
CPC分类号	A61B8/12 A61B1/00082 A61B1/00096 A61B1/00174 A61B8/4483		
优先权	2015126052 2015-06-23 JP		
其他公开文献	EP3315077A4		
外部链接	Espacenet		

摘要(译)

本发明的超声波内窥镜具备插入到被检体内的插入部，具备：超声波功能部，其设置于上述插入部的前端，具有超声波收发器，该超声波收发器被构成为收发超声波在包括所述插入部分的纵向轴线的表面上，所述表面平行于所述纵向轴线；以及连接到所述超声功能单元的内窥镜功能单元，所述内窥镜功能单元至少包括：具有能够锁定气球的凹槽形状的气球锁定部分；以及成像光学系统，其中，第一平面在插入部分的纵向轴线的方向上穿过超声换能器附近的内窥镜功能单元的端部，第一平面垂直于插入的纵轴并且所述第一平面位于比通过所述内窥镜功能单元的所述超声功能单元附近的端部的第二平面更靠近基端的位置，所述内窥镜功能单元的所述端部是所述超声功能单元与所述超声功能单元之间的边界，内窥镜功能单元。

FIG.4

