

(19)



(11)

**EP 3 190 976 B1**

(12)

**EUROPEAN PATENT SPECIFICATION**

(45) Date of publication and mention of the grant of the patent:  
**14.03.2018 Bulletin 2018/11**

(51) Int Cl.:  
**A61B 8/08 (2006.01) G01S 7/52 (2006.01)**

(21) Application number: **16754419.6**

(86) International application number:  
**PCT/EP2016/068250**

(22) Date of filing: **29.07.2016**

(87) International publication number:  
**WO 2017/021341 (09.02.2017 Gazette 2017/06)**

**(54) ULTRASOUND SYSTEM AND METHOD FOR MEASUREMENT USING SHEAR WAVES**

ULTRASCHALLSYSTEM UND VERFAHREN FÜR EINE MESSUNG MITTELS SCHERWELLEN

SYSTÈME À ULTRASONS ET PROCÉDÉ POUR UNE MESURE EN UTILISANT DES ONDES DE CISAILLEMENT

(84) Designated Contracting States:  
**AL AT BE BG CH CY CZ DE DK EE ES FI FR GB GR HR HU IE IS IT LI LT LU LV MC MK MT NL NO PL PT RO RS SE SI SK SM TR**

- **DENG, Yin, Hui**  
**5656 AE Eindhoven (NL)**
- **XIE, Hua**  
**5656 AE Eindhoven (NL)**
- **ZHOU, Shiwei**  
**5656 AE Eindhoven (NL)**

(30) Priority: **03.08.2015 PCT/CN2015/085935**  
**25.09.2015 EP 15186920**

(74) Representative: **Mumbrú Forn, José**  
**Société Civile SPID**  
**33, rue de Verdun**  
**92156 Suresnes Cedex (FR)**

(43) Date of publication of application:  
**19.07.2017 Bulletin 2017/29**

(73) Proprietor: **Koninklijke Philips N.V.**  
**5656 AE Eindhoven (NL)**

(56) References cited:  
**US-A1- 2011 263 978 US-A1- 2012 089 019**

(72) Inventors:  
• **SHAMDASANI, Vijay, Thakur**  
**5656 AE Eindhoven (NL)**

**EP 3 190 976 B1**

Note: Within nine months of the publication of the mention of the grant of the European patent in the European Patent Bulletin, any person may give notice to the European Patent Office of opposition to that patent, in accordance with the Implementing Regulations. Notice of opposition shall not be deemed to have been filed until the opposition fee has been paid. (Art. 99(1) European Patent Convention).

**Description**

## FIELD OF THE INVENTION

**[0001]** The present invention relates to an ultrasound system and method for measurement using shear wave, particularly to measuring a property of a region of interest in a subject by using shear wave.

## BACKGROUND OF THE INVENTION

**[0002]** Mechanical changes in living tissue correlate with pathological changes. For example, tissue viscosity, tissue stiffness (also known as elasticity) and tissue attenuation coefficients (including tissue longitudinal-wave attenuation, and tissue transverse-wave attenuation, which is also known as shear wave attenuation) are important physical parameters for clinical practice. Various means of remotely interrogating tissue mechanical properties have been developed that exploit the radiation force of an ultrasonic beam to apply force remotely to a region of tissue within the body of a subject such as a patient (acoustic radiation force, also referred to as a push pulse or push beam) to cause deformation of the tissue. Acoustic radiation force can be applied in such a way that elastic properties may be measured, either locally at the point (called focal point) of the deformation by tracking the deformation directly through the use of longitudinal-wave-based ultrasound imaging to follow the pattern of deformation, or at an adjacent region of the focal point by tracking a shear wave propagating laterally away from the deformed region (i.e. the focal point) through shear wave velocity imaging.

**[0003]** Interrogation by ultrasound, for purposes of medical imaging, often makes use of longitudinal waves. A longitudinal wave is characterized by back and forth movement in the direction of propagation. In the conventional tissue attenuation measurement based on a longitudinal wave, the tissue longitudinal-wave attenuation (also called tissue longitudinal attenuation) is estimated based on an ultrasound echo signal which is simultaneously impacted by both the backscatter and attenuation of tissue. Such conventional tissue longitudinal-wave attenuation measurement has the disadvantage that, since it is difficult to separate the impact of the backscatter from that of the tissue attenuation, the accuracy is limited.

**[0004]** An ultrasound shear (or transverse) wave, by contrast, is characterized by back and forth movement that is perpendicular to the direction of propagation. Nowadays, many commercial ultrasound scanners offer ultrasound shear wave elastography products to measure tissue shear elasticity. Tissue shear viscosity and shear wave attenuation estimation by means of shear wave elastography have not been commercialized yet. They remain scientifically active research topics as their clinical potential is emerging in certain applications. FIG. 1 illustrates measurement using shear wave according to the prior art. A push pulse (also known as push beam)

110 is transmitted toward a focal spot 130 to generate a shear wave 150 which propagates out from the focal spot in a direction, such as a lateral direction x, perpendicular to the propagation direction of the push pulse (i.e. the longitudinal direction z). One or more tracking pulses (also known as tracking beam) are transmitted, and ultrasound echo signals are received along a plurality of tracking lines (called "A-lines") 120, 122, 124 so as to estimate, at each of a plurality of sampling locations 140, 142, 144 spaced along the lateral direction, the phase or the propagation time of the shear wave. The estimated phases or propagation time of the shear wave at the plurality of sampling locations are further used to derive the velocity value of the shear wave. The derived velocity value of the shear wave can be used to generate an ultrasound image, which process is known as radiation force impulse imaging, and/or to derive a mechanical property such as tissue viscosity or elasticity. Such conventional shear wave elastography techniques can provide tissue shear elasticity, shear viscosity and shear wave attenuation.

**[0005]** US2012/0089019A1 and US2011/0263978A1 are both directed to conventional shear wave elastography techniques, namely estimating tissue mechanical property on basis of its impact on the propagation of the shear wave.

## SUMMARY OF THE INVENTION

**[0006]** Therefore, it would be advantageous to provide an improved ultrasound system and method for measuring a property (such as a tissue mechanical property) of a region of interest in a subject.

**[0007]** In accordance with an embodiment of a first aspect of the present invention, there is proposed an ultrasound imaging system. The ultrasound system comprises: an ultrasound probe configured to sequentially transmit, to each of a plurality of focal spots in the region of interest, a push pulse for generating a shear wave, each of the plurality of focal spots having a mutually different depth value, and to receive ultrasound echo signals adjacent to each of the plurality of focal spots; a shear wave detector configured to derive, for each of the plurality of focal spots, a first parameter indicating a property which the generated shear wave has at the focal spot, based on the received ultrasound echo signals; and a property estimator configured to estimate a second parameter indicating the property of the region of interest as a function of the derived first parameters.

**[0008]** In this way, a plurality of shear waves are excited at different depths in the region of interest and the property of the region of interest is estimated based on the intensities of the plurality of shear waves. The inventors of the present invention have recognized that the property of the region of interest impacts on the propagation of each push pulses as the push pulse propagates through the region of interest, and in turn impacts the respective shear wave excited by the push pulse at the focal spots in the region of interest, and thus the property

(such as intensity, phase) of the excited shear waves at the focal spots will be dependent on the property (such as tissue viscosity, tissue stiffness, tissue attenuation) of the region of interest. For example, the tissue attenuates the propagation of the push pulse in such a way that the higher the tissue longitudinal attenuation factor, the more the push pulse attenuates as it propagates through the tissue, and thus the intensity of the push pulse at the focal spot and in turn the intensity of the excited shear wave becomes lower. Based on such recognition, the inventors of the present invention have proposed to excite a plurality of shear waves at different focal depths in the region of interest, and estimate the property of the region of interest as a function of properties of the shear waves generated at the plurality of focal spots on basis of an impact of the property of the region of interest on the propagation of the push pulses along the longitudinal direction. In other words, the property of the region of interest is estimated based on the relationship between properties of the shear waves generated at the plurality of focal spots. For example, the first parameter derived for a focal spot can indicate a property (such as intensity, phase) which the generated shear wave has at the focal spot. To the contrary, in conventional shear wave elastography techniques, the property of the region of interest is estimated on basis of the impact of the property of the region of interest on the propagation of the shear wave along the traverse/lateral direction. Therefore, in conventional shear wave elastography techniques, the propagation property of the shear wave, such as propagation velocity or delay of the shear wave, is estimated, rather than any property, which the shear wave has at the focal spot before it even starts to propagate along the lateral direction, is estimated or derived.

**[0009]** Since the shear wave propagates in a direction perpendicular to the transmitting/receiving direction (i.e. the longitudinal direction) of the ultrasound signals, the measurement of the shear wave is not impacted by the backscatter of the ultrasound signals along the longitudinal direction. Thus, the above tissue property estimation does not have the aforementioned disadvantage of the conventional longitudinal wave-based tissue attenuation measurement.

**[0010]** In comparison to the conventional shear wave elastography techniques, additional properties of the region of interest can be estimated by combining the measured parameters of the plurality of shear waves. In some embodiments, the second parameter can indicate a longitudinal property of the region of interest, such as tissue longitudinal attenuation, tissue longitudinal viscosity, etc. As well-known, a tissue property may be the same in all directions, but may also be different in different direction. For example, a tissue mechanical property, such as tissue attenuation, tissue viscosity or tissue elasticity, in the longitudinal direction can be different from that in the traverse direction. A longitudinal property of the region of interest is known as the property of the region of interest along the longitudinal direction (i.e. the propagation

of a longitudinal wave), such as longitudinal attenuation, longitudinal viscosity. Likewise, a traverse property, also called a shear property, is known as the property of the region of interest along the traverse direction, such as traverse attenuation (also called shear attenuation), traverse viscosity, etc.

**[0011]** The number of focal spots can be set to any suitable values. Generally, the larger the number of focal spots, the more accurate the estimated property of the region of interest becomes. The ultrasound probe can comprise a one-dimensional or two-dimensional transducer array. The region of interest can be a region of tissue, for example a region of liver tissue, kidney tissue, prostate tissue, breast tissue, etc. The subject can be a human such as a patient, an animal, a phantom etc. The property of the generated shear wave at the focal spot can be properties in time domain or frequency domain, including but not limited to the displacement, the velocity, and/or the spectrum of the shear wave.

**[0012]** In accordance with an embodiment, the property of the region of interest comprises any one of attenuation, stiffness, and viscosity of the region of interest. The property of the region of interest can comprise any one of tissue attenuation, tissue stiffness, and tissue viscosity. The tissue attenuation can be longitudinal attenuation or shear attenuation. The property of the region of interest can comprise a longitudinal property of the region of interest. For example, the property of the region of interest can be longitudinal attenuation.

**[0013]** By developing a special shear wave excitation and tracking scheme, we propose an integrated approach that enables estimation of additional parameters such as longitudinal wave attenuation. The proposed approach is envisioned as a one-button push tool that provides multi-parameter tissue quantification based on both longitudinal and shear waves. Clinical studies have long indicated that the acoustic attenuation coefficient of the longitudinal wave is useful for fat quantification in soft tissue (e.g. fatty liver quantification). Recently developed shear wave elastography has emerged as a diagnostic tool for tissue characterization (e.g. liver fibrosis staging) and cancer detection (e.g. cancer detection for liver, breast, prostate and thyroid etc.).

**[0014]** In accordance with an embodiment, the first parameter for a focal spot is derived from a displacement of the generated shear wave at a tracking spot adjacent to the focal spot. In other words, each first parameter is derived from a displacement which the generated shear wave exhibits at a tracking spot adjacent to a respective focal spot. Various known approaches can be used to derive the shear wave displacement from the echo signals, either in time domain or frequency domain. In various embodiments, the first parameter indicate a peak displacement, average displacement or the like of the generated shear wave at the tracking spot. Since the tracking spot is adjacent to the respective focal spot and the displacement at the tracking spot can be regarded as being proportional to the displacement at the focal

spot, the derived first parameter can be used to indicate a displacement, such as a peak displacement, an average displacement or the like, of the generated shear wave at the respective focal spot.

**[0015]** In accordance with an embodiment, the first parameter is derived from a peak displacement of the generated shear wave at the tracking spot to indicate the peak displacement of the generated shear wave at the focal spot.

**[0016]** In accordance with an embodiment, the property estimator is configured to estimate a tissue longitudinal attenuation property of the region of interest by means of fitting an exponential curve with the derived first parameters.

**[0017]** In accordance with an embodiment, the ultrasound system further comprises an interface, wherein the interface is configured to receive an input for indicating the plurality of focal spots; and the property estimator is further configured to estimate the second parameter based on the focal depth value of each of the indicated plurality of focal spots. In an example, the user input can be the region of interest, and then the plurality of focal spots can be automatically set in accordance with a predetermined rule. For example, the plurality of focal spots can be set as a predetermined number of spots equally spaced across the region of interest. In another example, the input can be the plurality of focal spots. The interface can be a user interface or an interface with a system capable of delivering the required information, such as a hospital information system, patient information management system.

**[0018]** In accordance with an embodiment, the ultrasound system further comprises an intensity variation estimator configured to estimate, for each of the plurality of focal spots, an intensity variation of the push pulse caused by beamforming setting of the push pulse.

**[0019]** The inventors of the present invention recognize that the estimation of certain properties of the region of interest may utilize the initial acoustic intensity of the push pulse, but the initial acoustic intensity of the push pulse varies with the beam profile of the push pulse. In order to further improve the estimation regarding a property of the region of interest, the inventors of the present invention propose to estimate such variation and compensate for such variation.

**[0020]** In some embodiments, the ultrasound probe is further configured to adjust the intensity of the push pulse based on the estimated variation. In some other embodiments, the property estimator is further configured to estimate the second parameter based on the estimated variation.

**[0021]** In accordance with an embodiment, the shear wave detector is further configured, for each of the plurality of focal spots, to estimate a third parameter indicating a tissue shear property of the region of interest at the depth of the focal spot, and to adjust the first parameter based on the estimated third parameter, and the property estimator is further configured to derive the sec-

ond parameter as a function of the adjusted first parameters. For example, the shear property of the region of interest can be shear stiffness, shear viscosity, or shear attenuation of the region of interest. For example, the shear property at the depth of each focal spot can be estimated based on the velocity of the respective shear wave generated at that focal spot.

**[0022]** The inventors of the present invention recognize that the local shear properties at different depths may be different, and thus impact the estimation of the property of the region of interest, and therefore, they propose to adjust the first parameters with the local shear wave properties prior to the estimation of the property of the region of interest.

**[0023]** In accordance with an embodiment, the ultrasound probe is configured, for each of the plurality of focal spots, to transmit a tracking pulse toward a tracking spot adjacent to the focal spot, to receive an ultrasound echo signal from the tracking spot; and the shear wave detector is configured to derive, for each of the plurality of focal spots, the first parameter, based on the ultrasound echo signal received from a tracking spot adjacent to the focal spot.

**[0024]** In accordance with an embodiment of a second aspect of the present invention, there is proposed a method of measuring a property of a region of interest in a subject by using shear wave. The method comprises: sequentially transmitting, to each of a plurality of focal spots in the region of interest, a push pulse for generating a shear wave, each of the plurality of focal spots having a mutually different depth value, and for receiving ultrasound echo signals adjacent to each of the plurality of focal spots; deriving, for each of the plurality of focal spots, a first parameter indicating a property which the generated shear wave has at the focal spot, based on the received ultrasound echo signals; and estimating a second parameter indicating the property of the region of interest as a function of the derived first parameters.

**[0025]** In accordance with an embodiment of a third aspect of the present invention, there is provided a computer product, comprising computer program instructions which, when executed, perform the method of estimating a property of a region of interest in a subject based on a plurality of shear waves, each of the plurality shear waves being generated by transmitting a push pulse to a focal spot at a different depth, wherein the method comprises: deriving, for each of a plurality of focal spots, a first parameter indicating a property which the shear wave has at the focal spot, based on ultrasound echo signals received adjacent to each of the plurality of focal spots; and estimating a second parameter indicating the property of the region of interest as a function of the derived first parameters.

**[0026]** Other objects and advantages of the present invention will become more apparent and can be easily understood with reference to the description made in combination with the accompanying drawings.

## DESCRIPTION OF THE DRAWINGS

**[0027]** The present invention will be described and explained hereinafter in more detail in combination with embodiments and with reference to the drawings, wherein:

FIG.1 illustrates a conventional shear wave-based tissue viscosity or elasticity measurement in the prior art;

FIG.2 illustrates in a block diagram form an ultrasound imaging system constructed in accordance with some embodiments of the present invention;

FIG.3 illustrates a plurality of shear waves generated at a plurality of focal spots in the region of interest in accordance with some embodiments of the present invention;

FIG.4 illustrates the plurality of focal spots in the region of interest in accordance with some embodiments of the present invention; and

FIG.5 illustrates a beam profile of a push pulse focused at a focal depth in accordance with an embodiment of the present invention.

**[0028]** The same reference signs in the figures indicate similar or corresponding features and/or functionalities.

## DETAILED DESCRIPTION

**[0029]** The present invention will be described with respect to particular embodiments and with reference to certain drawings, but the invention is not limited thereto but only by the claims. The drawings described are only schematic and are non-limiting. In the drawings, the size of some of the elements may be exaggerated and not drawn to scale for illustrative purposes.

**[0030]** Referring first to FIG. 2, an ultrasound system constructed in accordance with some embodiments of the present invention is shown in block diagram form.

**[0031]** An ultrasound probe 10 has a one-dimensional or two-dimensional array 12 of transducer elements for transmitting and receiving ultrasound signals. The transducer array 12 can scan a two dimensional (2D) plane by transmitting beams and receiving returning echo signals over a single plane in the body, and can also be used to scan a volumetric region by transmitting beams in different directions and/or planes of a volumetric (3D) region of the body. The array elements are coupled to a micro-beamformer 38 located in the probe which controls transmission by the elements and processes the echo signals received from groups or sub-arrays of elements into partially beam-formed signals. The partially beam-formed signals are coupled from the probe to a multiline receive beamformer 20 in the ultrasound system by a transmit/receive (T/R) switch 14. Coordination of transmission and reception by the beamformers is controlled by a beamformer controller 16 coupled to the multiline receive beamformer and to a transmit controller 18, which provides control signals to the micro-beamformer. The

beamformer controller is responsive to signals produced in response to user manipulation of a user control panel 40 to control the operation of the ultrasound system and its probe. The multiline receive beamformer 20 produces one or more, spatially distinct, tracking lines (also known as receive lines or A-lines) of echo signals during a single transmit-receive interval.

**[0032]** In accordance with an embodiment of the present invention, the ultrasound probe is configured to sequentially transmit, to each of a plurality of focal spots in the region of interest, a push pulse for generating a shear wave, each of the plurality of focal spots having a mutually different focal depth value, and to receive ultrasound echo signals adjacent to each of the plurality of focal spots. For example, the ultrasound echo signals are received along an A-line adjacent to each focal spot.

**[0033]** The received echo signals are then coupled to a shear wave detector for further processing. The shear wave detector is configured to derive, for each of the plurality of focal spots, a first parameter of a property of the respective shear wave, based on the received ultrasound echo signals. The shear wave detector comprises a signal processor 22, an A-line memory 24, an A-line motion estimator (e.g. cross-correlator) 26, and an intensity detector 28. The echo signals are processed by filtering, noise reduction, and the like, by a signal processor 22, and are then stored in an A-line memory 24. The echo signals of successive A-line samplings are tracked by an A-line motion estimator 26 to produce a time sequence of samples of tissue displacement for each sampling location. The intensity detector 28 is responsive to detection of the shear wave displacement along the A-lines to determine the intensity of the shear wave. A property estimator 32 is coupled to estimate a second parameter indicating the property of the region of interest, based on a function of the derived first parameters. The shear wave detector and the property estimator 32 will be described in more detail below by referring to FIG. 3.

**[0034]** In some embodiments, the derived property information can be coupled to an image processor 34 which processes the property information, preferably in combination with the anatomical ultrasound image of the tissue, for display on an image display 36.

**[0035]** In some embodiments, the ultrasound system can further comprise an intensity variation estimator 40 configured to estimate, for each push pulse, a variation of an initial acoustic intensity of the push pulse caused by a beam profile of the push pulse. In an example, the ultrasound probe 10 is further configured to adjust the intensity of the push pulse based on the estimated variation. In this case, the intensity variation estimator 40 may be part of the beamformer controller 16. In another example, the property estimator 32 is configured to estimate the second parameter further, based on the estimated variation. Such intensity variation caused by a beam profile and the corresponding compensation will be described in more detail below by referring to FIG.5.

**[0036]** FIG.3 illustrates a plurality of shear waves gen-

erated at the plurality of focal spots in the region of interest in accordance with an embodiment of the present invention. Although three shear waves are illustrated in FIG. 3, a different number of shear waves may be generated in accordance with various embodiments.

**[0037]** Referring to FIG. 3, each of a plurality of push pulses 310, 312, 314 is focused at a different depth  $z_1$ ,  $z_2$ ,  $z_3$  under the skin surface. The tissue deformation caused at each focal spot 320, 322, 324 results in a shear wave 330, 332, 334 propagating along a lateral direction (such as direction  $x$  as illustrated) orthogonal to the longitudinal direction  $z$ .

**[0038]** The push pulse can be a focused high MI push pulse (e.g., MI of 1.9 or less so as to be within FDA diagnostic limits) which displaces the tissue at the focal spot downward and causes the development of a shear wave. Typically, ultrasound signals, e.g. the push pulse, travels at a speed of about 1560 meters/sec in tissue, shear waves travel at a speed of about 1-5 meters/sec in tissue, and a shear wave period in tissue is of the order of 2 to 10 milliseconds. In some embodiments, the plurality of push pulses can be sequentially transmitted at a predetermined time interval. For example, the predetermined time interval can be greater than at least one period of the shear wave.

**[0039]** FIG.4 illustrates a plurality of focal spots in the region of interest in accordance with some embodiments of the present invention. In FIG.4, direction  $z$  represents the longitudinal direction of the ultrasound probe 410, namely the propagation direction of ultrasound signals, also known as depth direction; directions  $x$  and  $y$  respectively represent the directions perpendicular to the longitudinal direction, namely the azimuth direction and elevation azimuth direction of the ultrasound probe 410. Although an ultrasound probe 410 comprising a two-dimensional transducer array has a three-dimensional field of view 420 is illustrated, it will be appreciated that an ultrasound probe having a one-dimensional transducer array can be used as well, and the region of interest can be two-dimensional or three-dimensional.

**[0040]** Referring to FIG.4, a plurality of spatial locations 440 inside the region of interest 430 are used as focal spots. Three focal spots are illustrated, but the present invention is not limited thereto and any number of focal spots may be defined. The focal spots 440 are located at different depths and, in other words, at different positions along the longitudinal direction  $z$ . In an embodiment, the plurality of focal spots can be spaced the same predetermined distance apart from each other along the longitudinal direction. The predetermined distance can be, for example, of the order of one centimeter. The plurality of focal spots 440 may have the same or a different position along the other two directions  $x$  and  $y$  in various embodiments.

**[0041]** The plurality of focal spots can be manually selected via a user interface. For example, an ultrasound image containing the region of interest is presented on a display, and then the user can select the focal spots

by entering the corresponding spatial locations in the displayed ultrasound image via any suitable user input means, including but not limited to joy stick, mouse, physical buttons, touch screen, etc. Additionally or alternatively, the focal spots can be automatically generated in the region of interest. For example, a predetermined number of focal spots may be generated, and/or a plurality of focal spots, spaced the same predetermined distance apart, may be generated. The predetermined number and/or the predetermined distance can be selected by the user or can be pre-defined.

**[0042]** The region of interest can also be manually selected via a user interface in a displayed ultrasound image, and/or can be automatically or semi-automatically defined by means of, for example, processing an ultrasound image.

**[0043]** Referring back to FIG.3, ultrasound echo signals are received along the tracking lines 340, 342, 344 adjacent to the focal spots to track the tissue displacement at the tracking spot 350, 352, 354. The inventors of the present invention have recognized that the shear wave tracking at the focal spot is not so accurate due to the push pulse reflection or reverberation, for example at a tracking spot adjacent to the focal spot, and thus they propose to track the shear wave displacement at tracking spots adjacent to the focal spot. Further, the tracking spots shall not be located too far away from the focal spot, because the shear wave displacement decreases quickly along the propagation direction. The distance between each focal spot and the nearest tracking spot can be any suitable value and can be different for different kinds of region of interest. For example, the distance between the tracking spot and the focal spot can be of the order of 0.1 cm. For example, the distance between the tracking spot and the focal spot can be set at half the push beam width away from the push focus

**[0044]** For each of the plurality of focal spots, a first parameter indicating a property of the shear wave is derived from the echo signals received along the respective tracking line. Taking focal spot 320 as an example, the first parameter derived for the focal spot 320 is derived from the echo signal received along the tracking line 340. In some embodiments, the first parameter derived for a focal spot may indicate a property value of the respective shear wave at that focal spot. In accordance with an embodiment of the present invention, the first parameter is derived as the peak value of the shear wave displacement at the tracking spot 350, 352, 354. In other examples, the first parameter may be derived as an average displacement or the like of the shear wave.

**[0045]** Next, a property of the region of interest is estimated as a function of the shear wave property values at the plurality of focal spots.. In some embodiments, the shear wave property value at each focal spot is modeled as a function of the intensity of the push pulse, the property of the region of interest, and the depth value of the focal spot, and then the unknown property of the region of interest may be derived in accordance with such a

model. Note that the unknown property to be derived is assumed to be the same within the region of interest. Taking the tissue attenuation as an example, the estimation in accordance with an embodiment is described below.

**[0046]** In accordance with an embodiment of the present invention, the peak or maximum displacement  $M_k$  of the  $k$ -th shear wave measured at the respective tracking spot can be modeled as being proportional to the intensity  $I_k$  of the push pulse multiplied by an exponential form whose exponent is a negative tissue attenuation coefficient  $\alpha$  multiplying the depth  $d_k$  of the respective focal spot, namely,

$$M_k = f(I_k, \alpha, d_k) = A \cdot I_k \cdot e^{-\alpha d_k}.$$

**[0047]** For example, the estimated tissue attenuation coefficient  $\alpha$  can be mathematically derived as:

$$\hat{\alpha} = \arg \min_{\alpha} \|M_k - f(I_k, \alpha, d_k)\|^2$$

**[0048]** For example, the estimation of the tissue attenuation coefficient can be performed by means of fitting an exponential curve with the derived first parameters  $M_k$ . In some embodiments, the intensity  $I_k$  of the push pulses 310, 312, 314 can be set as being substantially the same. In some other embodiments, the intensity of the push pulses 310, 312, 314 can be set to be different.

**[0049]** The inventors of the present invention have recognized that the estimation of certain properties of the region of interest may utilize the initial acoustic intensity of the push pulse, but the initial acoustic intensity of the push pulse varies with the beam profile of the push pulse. For example, the inventors have theoretically derived that the peak or maximum shear wave displacement  $M_d$  at the focal spot having depth value  $d$  is proportional to the initial acoustic intensity  $I_0$  of the push pulse multiplied by an exponential form whose exponent is a negative tissue attenuation coefficient  $\alpha$  multiplying the depth  $d$ , namely  $M_d \propto I_0 \cdot e^{-\alpha d}$ .

**[0050]** In order to further improve the estimation about the property of the region of interest, the inventors of the present invention propose to estimate such variation and compensate such variation.

**[0051]** FIG.5 illustrates a beam profile of a push pulse focused at a focal depth in accordance with an embodiment of the present invention. Referring to FIG. 5, the ultrasound probe 510 at the skin surface 520 transmits a push pulse with a beam profile 530 through the body 500 to a given focal spot in the region of interest. The focal spot is indicated by the shaded area 550 having a focal depth value  $d$ . This push pulse will displace the tissue at the focus in a downward direction, resulting in a shear wave front 540 emanating outward from the displaced tissue. For generating a certain beam profile, dif-

ferent transducer elements may be used, and different energy weights, phase shifts may be applied to the used transducer elements. This results in that the initial acoustic intensity  $I_0$  of the push pulse can be different even if the intensity of the push pulse is set to be the same. The variation of the initial acoustic intensity can be determined for a given beam profile.

**[0052]** In accordance with an embodiment of the present invention, an intensity estimator is configured to estimate such intensity variation. For example, when being provided by a beam profile, the intensity estimator can be configured to estimate the intensity variation of this beam profile by online calculation on the basis of a predetermined modeling, or by retrieving the intensity variation from a pre-stored look-up table.

**[0053]** In accordance with an embodiment of the present invention, the ultrasound probe is further configured to adjust the intensity of the push pulse based on the estimated intensity variation. For example, in order to achieve a predetermined initial acoustic intensity value, the intensity of a push pulse with a beam profile is determined on the basis of the predetermined initial acoustic intensity value and the estimated intensity variation caused by the beam profile, and then the ultrasound probe transmits the push pulse with the determined intensity. Alternatively, the property estimator is further configured to estimate the second parameter based on the estimated variation. For example, for a push pulse with a beam profile, the compensated initial acoustic intensity value can be determined on the basis of the intensity of the push pulse and the estimated intensity variation caused by the beam profile and then the property estimator uses the compensated initial acoustic intensity value to estimate the property of the region of interest.

**[0054]** In accordance with an embodiment, the shear wave detector is further configured, for each of the plurality of focal spots, to estimate a third parameter indicating a shear property of the region of interest at the depth of the focal spot, and to adjust the first parameter based on the estimated third parameter; and the property estimator is further configured to derive the second parameter as a function of the adjusted first parameters.

**[0055]** For example, the shear property of the region of interest can be shear stiffness or viscosity of the region of interest. For example, the shear property at the depth of each focal spot can be estimated based on the velocity of the respective shear wave generated at that focal spot.

**[0056]** The shear property of the region of interest at the depth of a focal spot can be estimated by means of conventional shear wave elastography techniques or any other suitable means developed in the future. In the case of using the conventional shear wave elastography techniques, for each of the generated shear waves, more than one tracking spots are spaced along the traverse direction  $x$  away from the respective focal spot, the ultrasound echo signals are received along the more than one tracking spots, the velocity of the respective shear

wave is derived from the received ultrasound echo signals, and then the shear property such as tissue shear stiffness and viscosity is estimated from the derived velocity of the respective shear wave.

**[0057]** The technique processes described herein may be implemented by various means. For example, these techniques may be implemented in hardware, software, or a combination thereof. For a hardware implementation, the processing units may be implemented within one or more application specific integrated circuits (ASICs), digital signal processors (DSPs), digital signal processing devices (DSPDs), programmable logic devices (PLDs), field programmable gate arrays (FPGAs), processors, controllers, microcontrollers, microprocessors, other electronic units designed to perform the functions described herein, or a combination thereof. In the case of software, implementation can be through modules (e.g., procedures, functions, and so on) that perform the functions described herein. The software codes may be stored in a memory unit and executed by the processors.

**[0058]** Moreover, aspects of the claimed subject matter may be implemented as a method, apparatus, system, or article of manufacture, using standard programming and/or engineering techniques to produce software, firmware, hardware, or any combination thereof to control a computer or computing components to implement various aspects of the claimed subject matter. The term "article of manufacture" as used herein is intended to encompass a computer program accessible from any computer-readable device, carrier, or media. For example, computer readable media can include but are not limited to magnetic storage devices (e.g., hard disk, floppy disk, magnetic strips...), optical disks (e.g., compact disk (CD), digital versatile disk (DVD)...), smart cards, and flash memory devices (e.g., card, stick, key drive...). Of course, those skilled in the art will recognize that many modifications may be made to this configuration without departing from the scope or spirit of what is described herein.

**[0059]** As used in this application, the terms "beam-former", "controller", "processor", "cross-correlator", "detector", "estimator" such as "shear wave detector", "property estimator" and "imaging encoder" are intended to refer to a processor or a computer-related entity, either hardware, a combination of hardware and software, software, or software in execution. For example, a component may be, but is not limited to, a process running on a processor, a processor, an object, an executable, a thread of execution, a program, and/or a computer. By way of illustration, both an application running on a server and the server can be a component. One or more components may reside within a process and/or thread of execution and a component may be localized on one computer and/or distributed among two or more computers.

## Claims

1. An ultrasound system for measuring a property of a region of interest in a subject by using shear wave, comprising:

an ultrasound probe (10) configured to sequentially transmit, to each of a plurality of focal spots (320, 322, 324) in the region of interest, a push pulse (310, 312, 314) for generating a shear wave (330, 332, 334), each of the plurality of focal spots having a mutually different depth value (z1, z2, z3), and to receive ultrasound echo signals adjacent (350, 352, 354) to each of the plurality of focal spots;

a shear wave detector (22, 24, 26, 28) configured to derive, for each of the plurality of focal spots, a first parameter indicating a property which the generated shear wave has at the focal spot based on the received ultrasound echo signals; and

a property estimator (32) configured to estimate a second parameter indicating the property of the region of interest as a function of the derived first parameters at the plurality of focal spots.

2. The ultrasound system of Claim 1, wherein the property of the region of interest comprises a longitudinal property of the region of interest, the longitudinal property of the region of interest being a property of the region of interest along the propagation direction of the push pulses.
3. The ultrasound system of Claim 1, wherein the first parameter derived for a focal spot indicates an intensity which the generated shear wave has at the focal spot.
4. The ultrasound system of any one of Claims 1 to 3, wherein the first parameter for a focal spot is derived from a displacement of the generated shear wave at a tracking spot adjacent to the focal spot.
5. The ultrasound system of Claim 4, wherein the first parameter is derived from a peak displacement of the generated shear wave at the tracking spot.
6. The ultrasound system of Claim 5, wherein the property estimator is configured to estimate a tissue longitudinal attenuation property of the region of interest by means of fitting an exponential curve with the derived first parameters.
7. The ultrasound system of any one of Claims 1 to 3, further comprising an interface (40), wherein the interface is configured to receive an input for indicating the plurality of focal spots; and the property estimator is further configured to esti-

mate the second parameter based on the focal depth value of each of the indicated plurality of focal spots.

8. The ultrasound system of any one of Claims 1 to 3, wherein the property estimator is configured to estimate the second parameter as a function of the derived first parameters and an intensity of the push pulses.
9. The ultrasound system of any one of Claims 1 to 8, further comprising an intensity variation estimator (40) configured to estimate, for each push pulse, a variation of an initial acoustic intensity of the push pulse caused by a beam profile of the push pulse.
10. The ultrasound system of Claim 9, wherein the ultrasound probe is further configured to adjust, for each push pulse, the intensity of the push pulse based on the estimated variation.
11. The ultrasound system of Claim 9, wherein the property estimator is further configured to estimate the second parameter based on the estimated variations.
12. The ultrasound system of any one of Claims 1 to 3, wherein the shear wave detector is further configured, for each of the plurality of focal spots, to estimate a third parameter indicating a shear property of the region of interest at the depth of the focal spot, and to adjust the first parameter based on the estimated third parameter; and the property estimator is further configured to derive the second parameter as a function of the adjusted first parameters at the plurality of focal spots.
13. A method of measuring a property of a region of interest in a subject by using shear wave, comprising:
  - sequentially transmitting, to each of a plurality of focal spots (320, 322, 324) in the region of interest, a push pulse (310, 312, 314) for generating a shear wave (330, 332, 334), each of the plurality of focal spots having a mutually different depth value ( $z_1, z_2, z_3$ ), and receiving ultrasound echo signals adjacent (350, 352, 354) to each of the plurality of focal spots;
  - deriving, for each of the plurality of focal spots, a first parameter indicating a property which the generated shear wave has at the focal spot, based on the received ultrasound echo signals; and
  - estimating a second parameter indicating the property of the region of interest as a function of the derived first parameters at the plurality of focal spots.

14. The method of Claim 13, wherein the second parameter indicates a longitudinal property of the region of interest, the longitudinal property of the region of interest being a property of the region of interest along the propagation direction of the push pulses.

15. A computer product, comprising computer program instructions which, when being executed, perform a method of estimating a property of a region of interest in a subject based on a plurality of shear waves (330, 332, 334), each of the plurality of shear waves being generated by transmitting a push pulse (310, 312, 314) to a focal spot (320, 322, 324) at a different depth ( $z_1, z_2, z_3$ ), the method comprising:

deriving, for each of a plurality of focal spots, a first parameter indicating a property which the shear wave has at the focal spot, based on ultrasound echo signals received adjacent to each of the plurality of focal spots; and estimating a second parameter indicating the property of the region of interest as a function of the derived first parameters at the plurality of focal spots.

#### Patentansprüche

1. Ultraschallsystem zum Messen einer Eigenschaft einer interessierenden Region in einem Subjekt unter Verwendung von Scherwellen, umfassend:
  - eine Ultraschallsonde (10), die dafür konfiguriert ist, sequentiell einen Push-Impuls (310, 312, 314) zum Erzeugen einer Scherwelle (330, 332, 334) an jeden einer Vielzahl von Brennflecken (320, 322, 324) in der interessierenden Region auszusenden, wobei jeder der Vielzahl von Brennflecken einen unterschiedlichen Tiefenwert ( $z_1, z_2, z_3$ ) hat, und Ultraschallechosignale (350, 352, 354) angrenzend an jeden der Vielzahl von Brennflecken zu empfangen;
  - einen Scherwellendetektor (22, 24, 26, 28), der dafür konfiguriert ist, basierend auf den empfangenen Ultraschallechosignalen für jeden der Vielzahl von Brennflecken einen ersten Parameter abzuleiten, der eine Eigenschaft angibt, welche die erzeugte Scherwelle an dem Brennfleck hat; und
  - eine Eigenschaftenschätzeinheit (32), die dafür ausgelegt ist, einen zweiten Parameter zu schätzen, der die Eigenschaft der interessierenden Region als eine Funktion der abgeleiteten ersten Parameter an der Vielzahl von Brennflecken angibt.
2. Ultraschallsystem nach Anspruch 1, wobei die Eigenschaft der interessierenden Region eine longitu-

- dinale Eigenschaft der interessierenden Region umfasst, wobei die longitudinale Eigenschaft der interessierenden Region eine Eigenschaft der interessierenden Region entlang der Ausbreitungsrichtung der Push-Impulse ist.
3. Ultraschallsystem nach Anspruch 1, wobei der für einen Brennfleck abgeleitete erste Parameter eine Intensität angibt, die die erzeugte Scherwelle an dem Brennfleck hat.
  4. Ultraschallsystem nach einem der Ansprüche 1 bis 3, wobei der erste Parameter für einen Brennfleck von einer Verschiebung der erzeugten Scherwelle an einem Verfolgungsfleck angrenzend an den Brennfleck abgeleitet wird.
  5. Ultraschallsystem nach Anspruch 4, wobei der erste Parameter von einer Spitzenverschiebung der erzeugten Scherwelle an dem Verfolgungsfleck abgeleitet wird.
  6. Ultraschallsystem nach Anspruch 5, wobei die Eigenschaftenschätzeinheit dafür konfiguriert ist, eine longitudinale Abschwächungseigenschaft des Gewebes der interessierenden Region zu schätzen, indem eine exponentielle Kurve mit den abgeleiteten ersten Parametern angepasst wird.
  7. Ultraschallsystem nach einem der Ansprüche 1 bis 3, weiterhin umfassend eine Schnittstelle (40), wobei die Schnittstelle dafür konfiguriert ist, eine Eingabe zum Angeben der Vielzahl von Brennflecken zu empfangen; und die Eigenschaftenschätzeinheit weiterhin dafür konfiguriert ist, den zweiten Parameter basierend auf dem fokalen Tiefenwert von jedem der angegebenen Vielzahl von Brennflecken zu schätzen.
  8. Ultraschallsystem nach einem der Ansprüche 1 bis 3, wobei die Eigenschaftenschätzeinheit dafür konfiguriert ist, den zweiten Parameter als eine Funktion der abgeleiteten ersten Parameter und einer Intensität der Push-Impulse zu schätzen.
  9. Ultraschallsystem nach einem der Ansprüche 1 bis 8, weiterhin umfassend eine Intensitätsveränderungsschätzeinheit (40), die dafür konfiguriert ist, für jeden Push-Impuls eine Veränderung einer anfänglichen akustischen Intensität des Push-Impulses zu schätzen, die durch ein Strahlenbündelprofil des Push-Impulses verursacht wird.
  10. Ultraschallsystem nach Anspruch 9, wobei die Ultraschallsonde weiterhin dafür konfiguriert ist, die Intensität des Push-Impulses für jeden Push-Impuls basierend auf der geschätzten Veränderung anzupassen.
  11. Ultraschallsystem nach Anspruch 9, wobei die Eigenschaftenschätzeinheit weiterhin dafür konfiguriert ist, den zweiten Parameter basierend auf den geschätzten Veränderungen zu schätzen.
  12. Ultraschallsystem nach einem der Ansprüche 1 bis 3, wobei der Scherwellendetektor weiterhin dafür konfiguriert ist, für jeden der Vielzahl von Brennflecken einen dritten Parameter zu schätzen, der eine Schereigenschaft der interessierenden Region bei der Tiefe des Brennflecks angibt, und den ersten Parameter basierend auf dem geschätzten dritten Parameter anzupassen; und die Eigenschaftenschätzeinheit weiterhin dafür konfiguriert ist, den zweiten Parameter als eine Funktion der angepassten ersten Parameter an der Vielzahl von Brennflecken abzuleiten.
  13. Verfahren zum Messen einer Eigenschaft einer interessierenden Region in einem Subjekt unter Verwendung von Scherwellen, umfassend:
    - sequentielles Aussenden eines Push-Impulses (310, 312, 314) zum Erzeugen einer Scherwelle (330, 332, 334) an jeden einer Vielzahl von Brennflecken (320, 322, 324) in der interessierenden Region, wobei jeder der Vielzahl von Brennflecken einen unterschiedlichen Tiefenwert ( $z_1, z_2, z_3$ ) hat, und Empfangen von Ultraschallechosignalen (350, 352, 354) angrenzend an jeden der Vielzahl von Brennflecken; Ableiten, für jeden der Vielzahl von Brennflecken und basierend auf den empfangenen Ultraschallechosignalen, eines ersten Parameters, der eine Eigenschaft angibt, welche die erzeugte Scherwelle an dem Brennfleck hat; und Schätzen eines zweiten Parameters, der die Eigenschaft der interessierenden Region als eine Funktion der abgeleiteten ersten Parameter an der Vielzahl von Brennflecken angibt.
  14. Verfahren nach Anspruch 13, wobei der zweite Parameter eine longitudinale Eigenschaft der interessierenden Region angibt, wobei die longitudinale Eigenschaft der interessierenden Region eine Eigenschaft der interessierenden Region entlang der Ausbreitungsrichtung der Push-Impulse ist.
  15. Computerprodukt, umfassend Computerprogrammweisungen, die, wenn sie ausgeführt werden, ein Verfahren zum Schätzen einer Eigenschaft einer interessierenden Region in einem Objekt basierend auf einer Vielzahl von Scherwellen (330, 332, 334) durchführen, wobei jede der Vielzahl von Scherwellen durch Aussenden eines Push-Impulses (310, 312, 314) an einen Brennfleck (320, 322, 324) bei einer unterschiedlichen Tiefe ( $z_1, z_2, z_3$ ) erzeugt

wird, wobei das Verfahren Folgendes umfasst:

Ableiten, für jeden einer Vielzahl von Brennflecken, eines ersten Parameters, der eine Eigenschaft der Scherwelle an dem Brennfleck angibt, basierend auf Ultraschallechosignalen, die angrenzend an jeden der Vielzahl von Brennflecken empfangen werden; und  
Schätzen eines zweiten Parameters, der eine Eigenschaft der interessierenden Region als eine Funktion der abgeleiteten ersten Parameter an der Vielzahl von Brennflecken angibt.

## Revendications

1. Système à ultrasons pour mesurer une propriété d'une région d'intérêt chez un sujet en utilisant des ondes de cisaillement, comprenant :

une sonde à ultrasons (10) configurée pour transmettre en séquence à chacun d'une pluralité de foyers (320, 322, 324) dans la région d'intérêt une impulsion de poussée (310, 312, 314) pour générer une onde de cisaillement (330, 332, 334), chacun de la pluralité de foyers ayant une valeur de profondeur mutuellement différente ( $z_1$ ,  $z_2$ ,  $z_3$ ) et pour recevoir des signaux d'écho ultrasonores (350, 352, 354) adjacents à chacun de la pluralité de foyers ;  
un détecteur d'ondes de cisaillement (22, 24, 26, 28) configuré pour dériver pour chacun de la pluralité de foyers un premier paramètre indiquant une propriété que l'onde de cisaillement générée présente au foyer sur la base des signaux d'écho ultrasonores reçus ; et  
un estimateur de propriétés (32) configuré pour estimer un deuxième paramètre indiquant la propriété de la région d'intérêt en fonction des premiers paramètres dérivés dans la pluralité de foyers.

2. Système à ultrasons selon la revendication 1, dans lequel la propriété de la région d'intérêt comprend une propriété longitudinale de la région d'intérêt, la propriété longitudinale de la région d'intérêt étant une propriété de la région d'intérêt dans la direction de propagation des impulsions de poussée.
3. Système à ultrasons selon la revendication 1, dans lequel le premier paramètre dérivé pour un foyer indique une intensité que l'onde de cisaillement générée présente au foyer.
4. Système à ultrasons selon l'une quelconque des revendications 1 à 3, dans lequel le premier paramètre pour un foyer est dérivé d'un déplacement de l'onde de cisaillement générée en un point de suivi adjacent

au foyer.

5. Système à ultrasons selon la revendication 4, dans lequel le premier paramètre est dérivé d'un déplacement maximal de l'onde de cisaillement générée au point de suivi.
6. Système à ultrasons selon la revendication 5, dans lequel l'estimateur de propriété est configuré pour estimer une propriété d'atténuation longitudinale d'un tissu de la région d'intérêt en adaptant une courbe exponentielle aux premiers paramètres dérivés.
7. Système à ultrasons selon l'une quelconque des revendications 1 à 3, comprenant en outre une interface (40), dans lequel :

l'interface est configurée pour recevoir une entrée pour indiquer la pluralité de foyers ; et  
l'estimateur de propriété est en outre configuré pour estimer le deuxième paramètre sur la base de la valeur de profondeur focale de chacun de la pluralité indiquée de foyers.

8. Système à ultrasons selon l'une quelconque des revendications 1 à 3, dans lequel l'estimateur de propriété est configuré pour estimer le deuxième paramètre en fonction des premiers paramètres dérivés et d'une intensité des impulsions de poussée.
9. Système à ultrasons selon l'une quelconque des revendications 1 à 8, comprenant en outre un estimateur de variation d'intensité (40) configuré pour estimer pour chaque impulsion de poussée une variation d'une intensité acoustique initiale de l'impulsion de poussée provoquée par un profil de faisceau de l'impulsion de poussée.
10. Système à ultrasons selon la revendication 9, dans lequel la sonde à ultrasons est en outre configurée pour ajuster pour chaque impulsion de poussée l'intensité de l'impulsion de poussée sur la base de la variation estimée.
11. Système à ultrasons selon la revendication 9, dans lequel l'estimateur de propriété est en outre configuré pour estimer le deuxième paramètre sur la base des variations estimées.
12. Système à ultrasons selon l'une quelconque des revendications 1 à 3, dans lequel :

le détecteur d'ondes de cisaillement est en outre configuré, pour chacun de la pluralité de foyers, pour estimer un troisième paramètre indiquant une propriété de cisaillement de la région d'intérêt à la profondeur du foyer et pour ajuster le premier paramètre sur la base du troisième pa-

ramètre estimé ; et  
 l'estimateur de propriété est en outre configuré  
 pour dériver le deuxième paramètre en fonction  
 des premiers paramètres ajustés dans la pluralité  
 de foyers.

5

13. Procédé de mesure d'une propriété d'une région  
 d'intérêt chez un sujet en utilisant des ondes de cisaillement, comprenant :

10

la transmission en séquence à chacun d'une  
 pluralité de foyers (320, 322, 324) de la région  
 d'intérêt d'une impulsion de poussée (310, 312,  
 314) pour générer une onde de cisaillement  
 (330, 332, 334), chacun de la pluralité de foyers  
 ayant une valeur de profondeur mutuellement  
 différente ( $z_1$ ,  $z_2$ ,  $z_3$ ) et la réception de signaux  
 d'écho ultrasonores (350, 352, 354) adjacents  
 à chacun de la pluralité de foyers ;

15

la déduction pour chacun de la pluralité de  
 foyers d'un premier paramètre indiquant une  
 propriété que l'onde de cisaillement générée  
 présente au foyer sur la base des signaux  
 d'écho ultrasonores reçus ; et

20

l'estimation d'un deuxième paramètre indiquant  
 la propriété de la région d'intérêt en fonction des  
 premiers paramètres dérivés dans la pluralité  
 de foyers.

25

14. Procédé selon la revendication 13, dans lequel le  
 deuxième paramètre indique une propriété longitudinale  
 de la région d'intérêt, la propriété longitudinale  
 de la région d'intérêt étant une propriété de la région  
 d'intérêt dans la direction de propagation des impulsions  
 de poussée.

30

35

15. Produit informatique comprenant des instructions de  
 programme informatique qui, lorsqu'elles sont exécutées,  
 réalisent un procédé d'estimation d'une propriété  
 d'une région d'intérêt chez un sujet sur la base  
 d'une pluralité d'ondes de cisaillement (330, 332,  
 334), chacune de la pluralité d'ondes de cisaillement  
 étant générée en transmettant une impulsion de  
 poussée (310, 312, 314) à un foyer (320, 322, 324)  
 à une profondeur différente ( $z_1$ ,  $z_2$ ,  $z_3$ ), le procédé  
 comprenant :

40

45

la déduction pour chacun d'une pluralité de  
 foyers d'un premier paramètre indiquant une  
 propriété que l'onde de cisaillement présente au  
 foyer sur la base de signaux d'écho ultrasonores  
 reçus adjacents à chacun de la pluralité de  
 foyers ; et

50

l'estimation d'un deuxième paramètre indiquant  
 la propriété de la région d'intérêt en fonction des  
 premiers paramètres dérivés dans la pluralité  
 de foyers.

55

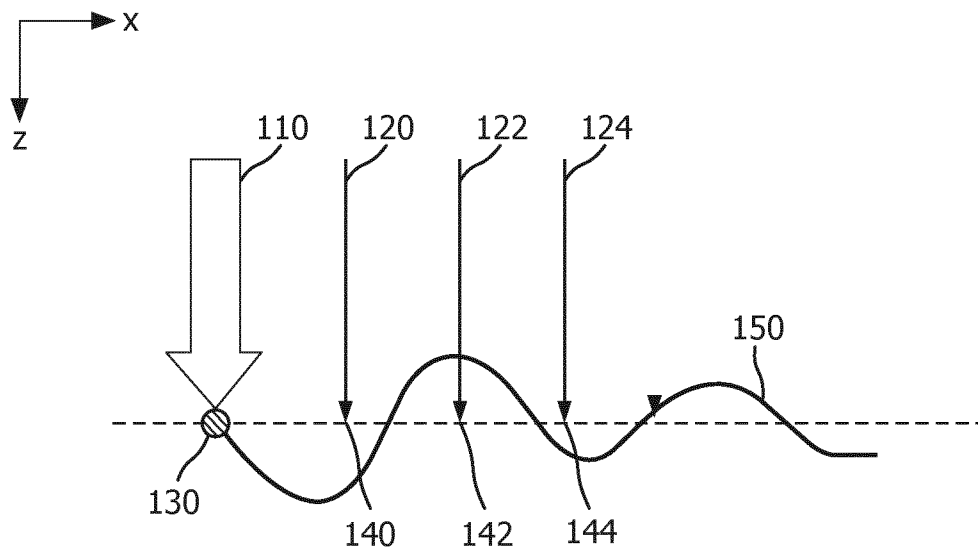

FIG. 1

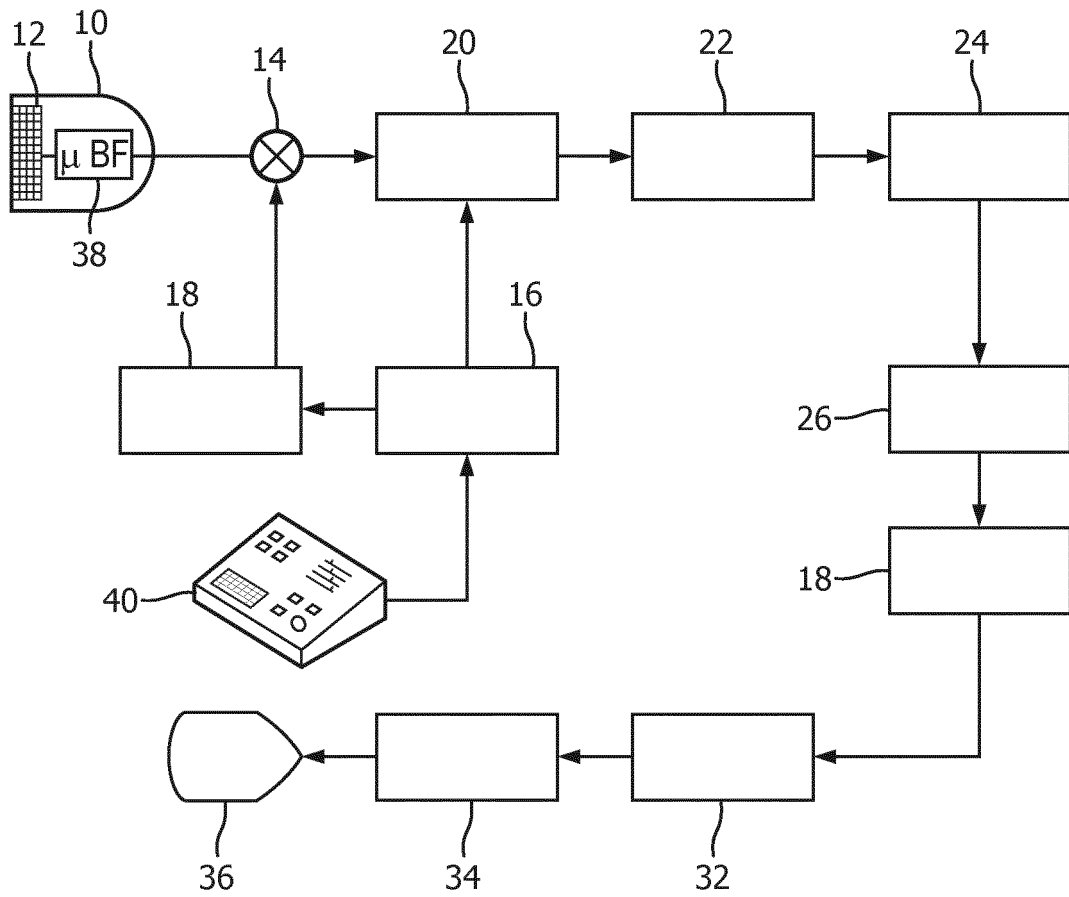

FIG. 2

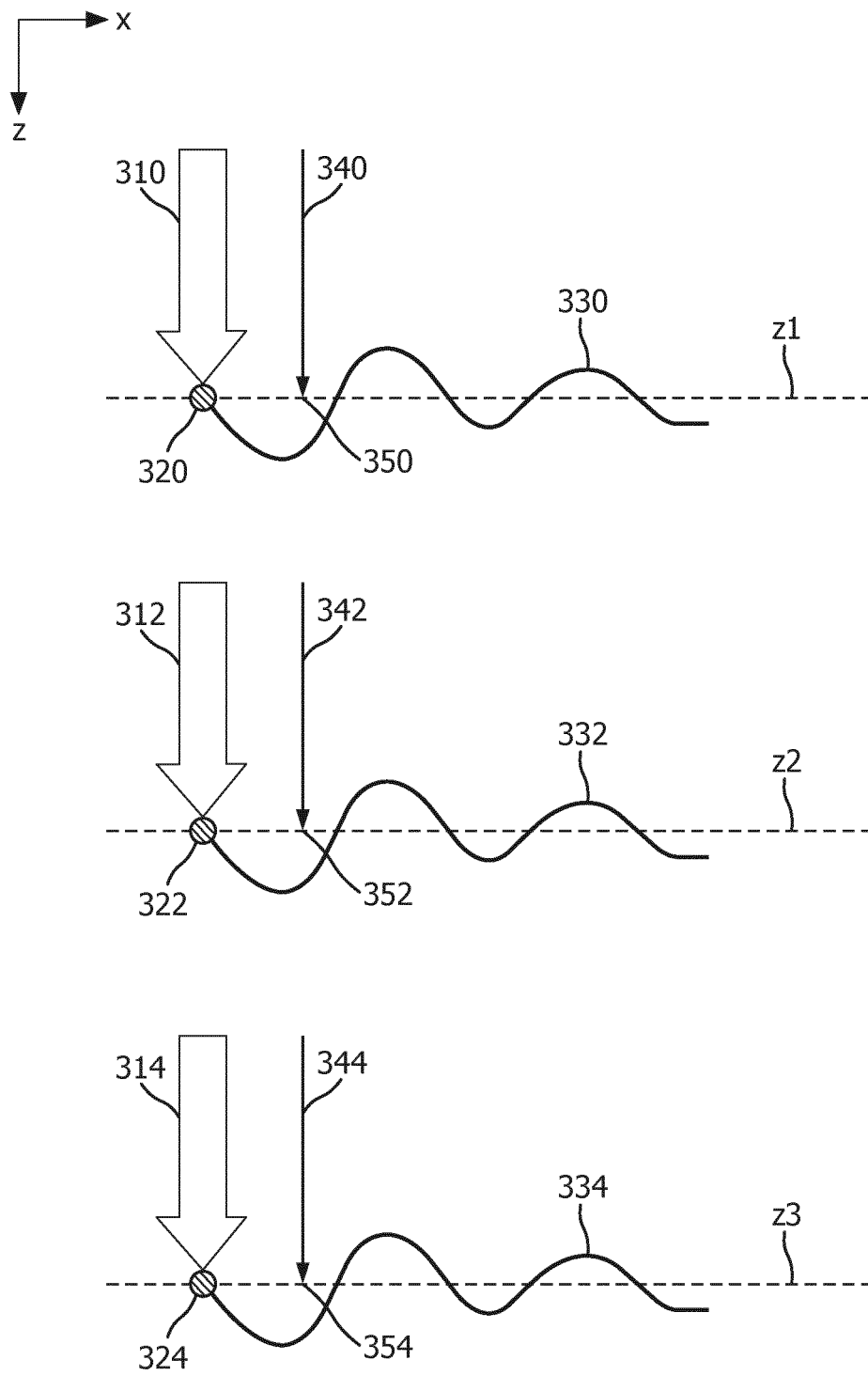

FIG. 3

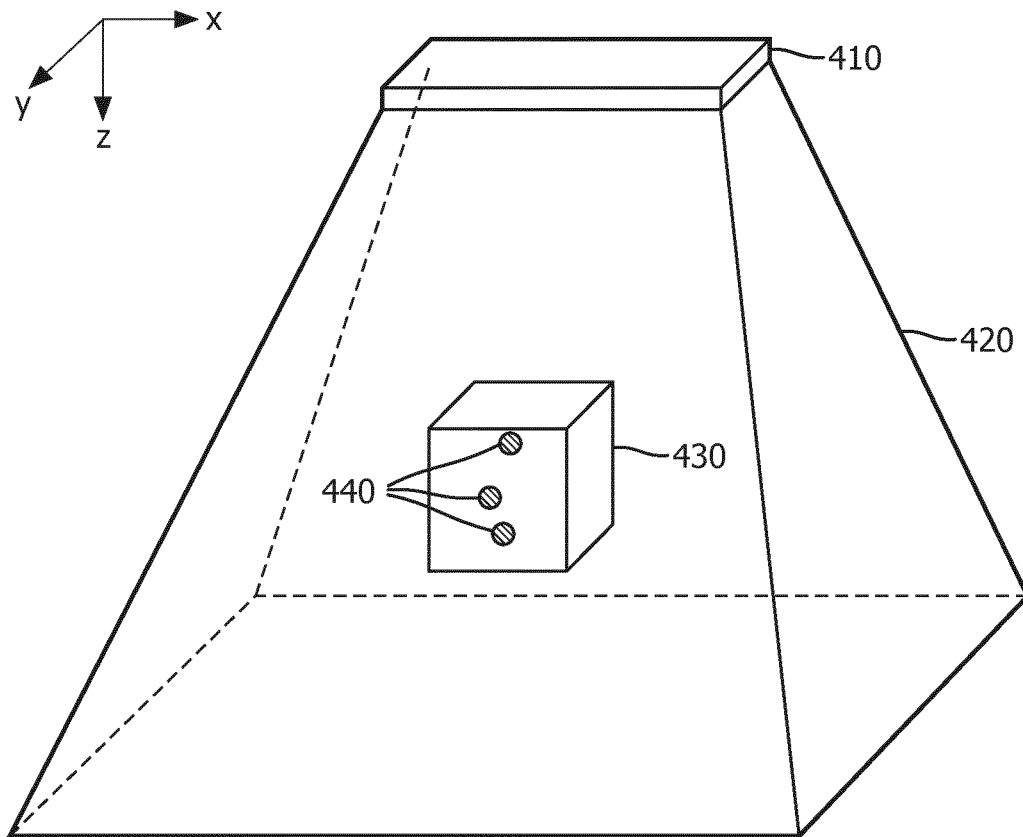

FIG. 4

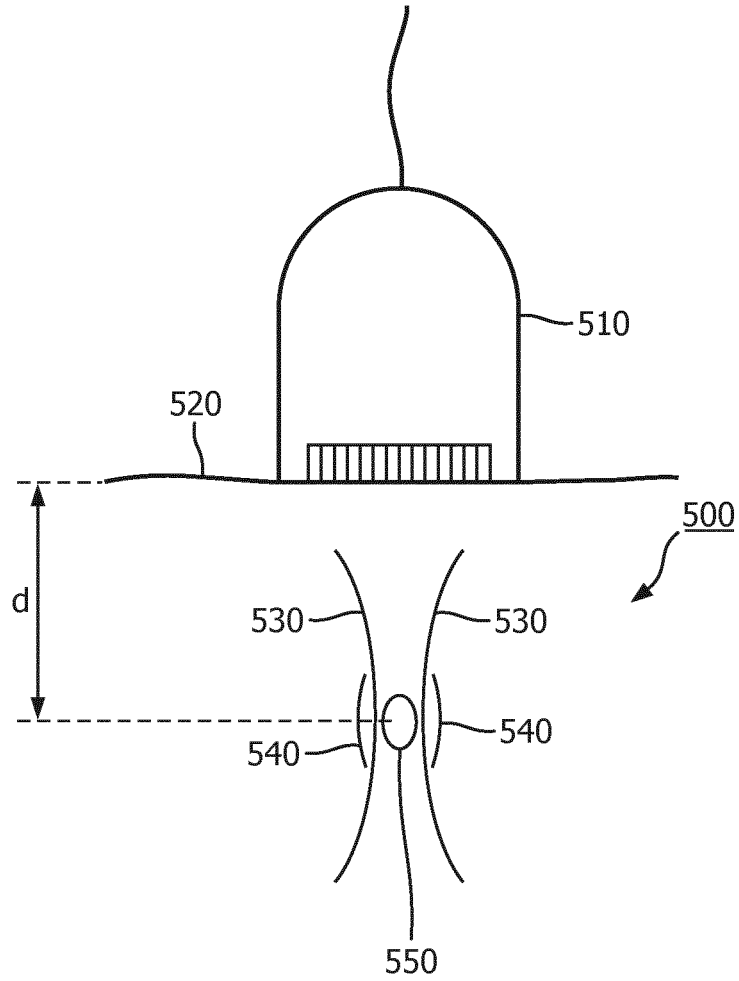

FIG. 5

**REFERENCES CITED IN THE DESCRIPTION**

*This list of references cited by the applicant is for the reader's convenience only. It does not form part of the European patent document. Even though great care has been taken in compiling the references, errors or omissions cannot be excluded and the EPO disclaims all liability in this regard.*

**Patent documents cited in the description**

- US 20120089019 A1 [0005]
- US 20110263978 A1 [0005]

专利名称(译)	超声系统和使用剪切波测量的方法		
公开(公告)号	<a href="#">EP3190976B1</a>	公开(公告)日	2018-03-14
申请号	EP2016754419	申请日	2016-07-29
[标]申请(专利权)人(译)	皇家飞利浦电子股份有限公司		
申请(专利权)人(译)	皇家飞利浦N.V.		
当前申请(专利权)人(译)	皇家飞利浦N.V.		
[标]发明人	SHAMDASANI VIJAY THAKUR DENG YIN HUI XIE HUA ZHOU SHIWEI		
发明人	SHAMDASANI, VIJAY, THAKUR DENG, YIN, HUI XIE, HUA ZHOU, SHIWEI		
IPC分类号	A61B8/08 G01S7/52		
CPC分类号	A61B8/085 A61B8/485 A61B8/5223 G01S7/52022 G01S7/52042 G01S7/5208 G01S7/52095 G01S15/8927		
优先权	PCT/CN2015/085935 2015-08-03 WO 2015186920 2015-09-25 EP		
其他公开文献	EP3190976A1		
外部链接	<a href="#">Espacenet</a>		

摘要(译)

本发明提出一种超声成像系统和方法，用于通过使用剪切波测量对象中的感兴趣区域的特性，其中超声探头被配置为顺序地发送到多个焦点 ( 320,322, 324 ) 在感兴趣的区域中，用于产生剪切波 ( 330,312,334 ) 的推动脉冲 ( 310,312,314 )，多个焦点中的每一个具有相互不同的深度值 ( z1, z2, z3 ) 并且，接收与多个焦点中的每一个相邻的超声回波信号 ( 350,352,354 )；剪切波检测器被配置为基于所接收的超声回波信号，为多个焦点中的每一个导出指示所生成的剪切波的特性的第一参数；并且属性估计器被配置为根据导出的第一参数估计指示感兴趣区域342的属性的第二参数。

$$M_k = f(l_k, a, d_k) = A \cdot l_k \cdot e^{-\alpha d_k}$$