

(19)



(11)

EP 3 138 500 B1

(12)

EUROPEAN PATENT SPECIFICATION

(45) Date of publication and mention of the grant of the patent:
08.05.2019 Bulletin 2019/19

(51) Int Cl.:
A61B 8/00 (2006.01) G01N 29/24 (2006.01)

(21) Application number: **15786419.0**

(86) International application number:
PCT/KR2015/002433

(22) Date of filing: **13.03.2015**

(87) International publication number:
WO 2015/167122 (05.11.2015 Gazette 2015/44)

(54) **ULTRASONIC SYSTEM AND METHOD APPLICABLE TO WIRELESS COMMUNICATION TERMINAL HAVING VARIOUS RESOLUTION LEVELS**

ULTRASCHALLSYSTEM UND VERFAHREN FÜR EIN DRAHTLOSKOMMUNIKATIONSENDGERÄT MIT MEHREREN AUFLÖSUNGSTUFEN

SYSTÈME DE ULTRASONORE ET PROCÉDÉ APPLICABLE À UN TERMINAL DE COMMUNICATION SANS FIL AYANT DIVERS NIVEAUX DE RÉOLUTION

(84) Designated Contracting States:
AL AT BE BG CH CY CZ DE DK EE ES FI FR GB GR HR HU IE IS IT LI LT LU LV MC MK MT NL NO PL PT RO RS SE SI SK SM TR

- **CHOUNG, You Chan**
Seoul 122-807 (KR)
- **CHUNG, Wook Jin**
Seoul 135-950 (KR)

(30) Priority: **28.04.2014 KR 20140050669**

(74) Representative: **Brann AB**
P.O. Box 3690
Drottninggatan 27
103 59 Stockholm (SE)

(43) Date of publication of application:
08.03.2017 Bulletin 2017/10

(73) Proprietor: **Healcerion Co., Ltd.**
Seoul 152-848 (KR)

(56) References cited:
WO-A1-2013/118359 JP-A- 2013 000 312
JP-A- 2013 000 312 JP-A- 2013 158 479
KR-A- 20120 029 679 KR-A- 20140 026 289
US-A1- 2008 114 245 US-A1- 2014 024 939
US-B1- 6 440 072

(72) Inventors:
• **RYU, Jeong Won**
Seoul 137-140 (KR)

EP 3 138 500 B1

Note: Within nine months of the publication of the mention of the grant of the European patent in the European Patent Bulletin, any person may give notice to the European Patent Office of opposition to that patent, in accordance with the Implementing Regulations. Notice of opposition shall not be deemed to have been filed until the opposition fee has been paid. (Art. 99(1) European Patent Convention).

Description

[Technical Field]

5 **[0001]** The present invention relates to an ultrasonic diagnostic system and method applicable to a wireless communication terminal with various resolution levels, and more particularly, to an ultrasonic diagnostic system and method applicable to a wireless communication terminal with various resolution levels, capable of embodying resolution adequate for the wireless communication terminal with various resolution levels and efficiently utilizing a transmission/reception bandwidth at the same time.

10 [Background Art]

[0002] With noninvasive and nondestructive properties, ultrasonic diagnostic apparatuses are generally used in the medical field to obtain information of the inside of an object. Since it is possible to provide a high-resolution image of internal organizations of the object to a doctor with no surgical operations of directly incising and observing the object, ultrasonic diagnostic systems are very importantly used in the medical field.

[0003] Ultrasonic diagnostic apparatuses are systems which emit an ultrasonic signal from a body surface of an object toward a target portion inside the object, extract information from a reflected ultrasonic signal, and obtain an image of a section of soft tissue or a blood flow in a noninvasive manner.

20 **[0004]** Compared with other imaging diagnostic apparatuses such as X-ray inspection apparatuses, computerized tomography (CT) scanners, magnetic resonance image (MRI) scanners, and nuclear medicine inspection apparatuses, since having a small size, being cheap, being capable of displaying in real time, and having excellent safety without being exposed to X-rays, ultrasonic diagnostic systems described above are generally used to diagnose hearts, internal organs in an abdominal cavity, urinary systems, and genital organs.

25 **[0005]** FIG. 1 is a block diagram schematically illustrating an ultrasonic diagnostic system.

[0006] As shown in the drawing, the ultrasonic diagnostic system includes an ultrasonic probe 10, a beam former 20, a scan-converting portion 30, and a display portion 40.

[0007] The ultrasonic probe 10 transmits an ultrasonic signal to an object and forms a reception signal by receiving an echo signal reflected from the object. Also, the ultrasonic probe 10 includes at least one transducer element which operates to transduce an ultrasonic signal and an electric signal into each other.

30 **[0008]** The beam former 20 analog/digital-converts and time-delays the reception signal provided from the ultrasonic probe 10 considering a position and a focused point of each of the transducer elements and forms frame data by adding up time-delayed digital signals.

[0009] The scan-converting portion 30 generates an ultrasonic image by performing scan-conversion to display the frame data on a display screen of a display portion.

[0010] The display portion 40 displays scan-converted ultrasonic data as the ultrasonic image on the display screen.

[0011] FIG. 2 is a view of a conventional ultrasonic diagnostic system used in a clinic.

[0012] As shown in the drawing, since the conventional ultrasonic diagnostic system has a monitor for displaying to display an ultrasonic image which is fixedly mounted therein, the ultrasonic image is generated according to a certain resolution level.

40 **[0013]** Recently, it has been tried to perform ultrasonic diagnosis by connecting various wireless communication terminals such as a smart phone and a tablet personal computer to the ultrasonic diagnostic system through wireless communication.

[0014] However, since wireless communication terminals described above include a display with various resolution levels, it is necessary to adjust a resolution level to transmit an ultrasonic image with a resolution level different from that of a general ultrasonic diagnostic system to a wireless communication terminal.

[0015] In addition, when the wireless communication terminal includes a display portion with a resolution level lower than an ultrasonic image generated by the ultrasonic diagnostic system, it is impossible to efficiently utilize a transmission/reception bandwidth when the ultrasonic image generated by the general ultrasonic diagnostic system is transmitted to the wireless communication terminal.

[0016] Accordingly, a practical and applicable technology with respect to an ultrasonic diagnostic system capable of providing resolution adequate for a wireless communication terminal with various resolution levels and efficiently utilizing a transmission/reception bandwidth at the same time is urgently needed.

55 **[0017]** US 2008/114245 discloses an ultrasonic diagnostic apparatus having transducer which transmits the scanned data merged with control data to a main unit via wireless communication.

[0018] WO2013/118359 discloses an ultrasonic apparatus comprising a scan converter module which performs conversion process which converts received frame data obtained by wave receiving and transmitting ultrasonic wave into display frame data. A control unit controls the conversion process in the scan converter module based on the native

display resolution of the indicator, and the display magnification of ultrasonographic image.

[Disclosure]

5 [Technical Problem]

[0019] The present invention is defined by the appended claims and provides an ultrasonic diagnostic system and method capable of providing resolution adequate for a wireless communication terminal with various resolution levels and efficiently utilizing a transmission/reception bandwidth at the same time.

10

[Technical Solution]

[0020] One aspect of the present invention provides an ultrasonic diagnostic system formed of an ultrasonic diagnostic apparatus and a wireless communication terminal and applicable to a wireless communication terminal with various resolution levels, including the ultrasonic diagnostic apparatus which converts frame data obtained by collecting an echo signal at an ultrasonic probe into scan data corresponding to a resolution level of a display screen of the wireless communication terminal and the wireless communication terminal which receives the scan data from the ultrasonic diagnostic apparatus and scan-converts the scan data into an ultrasonic image adequate for the resolution level of the display screen thereof.

15

[0021] The ultrasonic diagnostic apparatus may include an ultrasonic probe which transmits an ultrasonic signal to an object and receives an echo signal reflected by the object, a beam former which generates frame data by collecting the echo signal reflected from the ultrasonic probe, a resolution information reception portion which receives resolution information from the wireless communication terminal, a scan data resolution database (DB) in which scan data capable of corresponding to the resolution information of the wireless communication terminal with various resolution levels and increasing efficiency of a bandwidth while performing wireless communication, a scan data generation portion which compares the resolution information received by the resolution information reception portion with mapping information of the scan data resolution DB and generates scan data to be transmitted to the wireless communication terminal using the frame data, and a scan data transmission portion which transmits the scan data generated by the scan data generation portion to the wireless communication terminal.

20

25

[0022] The wireless communication terminal may include a display portion which displays an ultrasonic image, a resolution information generation portion which generates resolution information corresponding to a display screen of the display portion, a data transmission/reception portion which transmits and receives the resolution information and scan data by performing wireless communication with the ultrasonic diagnostic apparatus, a scan-conversion resolution DB in which a size of an ultrasonic image capable of being scan-converted corresponding to the resolution information, which is set and mapped in advance, is stored, an application control portion which maps an ultrasonic image corresponding to the resolution information of the display screen using the scan-conversion resolution DB, and a scan-conversion portion which scan-converts the scan data received from the ultrasonic diagnostic apparatus into an ultrasonic image adequate for a resolution level of the display screen.

30

35

[0023] Another aspect of the present invention provides a diagnostic method of an ultrasonic diagnostic system applicable to a wireless communication terminal with various resolution levels and including an ultrasonic diagnostic apparatus which forms scan data corresponding to a resolution level of a display screen of the wireless communication terminal using frame data obtained by collecting an echo signal from an ultrasonic probe and the wireless communication terminal which receives the scan data from the ultrasonic diagnostic apparatus and scan-convert the scan data into an ultrasonic image adequate for the resolution level of the display screen. The method includes a first operation of generating the frame data, by a beam former, by collecting the echo signal of the ultrasonic probe, a second operation of generating resolution information of the display screen, by a resolution generation portion of the wireless communication terminal, using a device driver, a third operation of transmitting the resolution information from the wireless communication terminal to the ultrasonic diagnostic apparatus through a data transmission/reception portion of the wireless communication terminal and a resolution information reception portion of the ultrasonic diagnostic apparatus, a fourth operation of comparing the resolution information of the wireless communication terminal with mapping information of a scan data resolution DB and then generating scan data to be transmitted to the wireless communication terminal using the frame data generated by the beam former according to the mapping information, a fifth operation of transmitting the scan data from the ultrasonic diagnostic apparatus to the wireless communication terminal through a scan data transmission portion of the ultrasonic diagnostic apparatus and the data transmission/reception of the wireless communication terminal, a sixth operation of mapping an ultrasonic image corresponding to the resolution information, by an application control portion, by referring to a scan-conversion resolution DB and then scan-converting the scan data received from the ultrasonic diagnostic apparatus, by a scan-conversion portion, into an ultrasonic image adequate for the resolution information of the display screen, and a seventh operation of displaying the ultrasonic image on which scan conversion

40

45

50

55

is completed by a display portion.

[Advantageous Effects]

5 **[0024]** As described above, according to the embodiments of the present invention, since frame data formed by a beam former of an ultrasonic diagnostic apparatus is formed as scan data corresponding to a resolution level of a wireless communication terminal and then transmitted to the wireless communication terminal, a transmission/reception bandwidth may be efficiently utilized.

10 **[0025]** Also, since the scan data transmitted from the ultrasonic diagnostic apparatus may be independently scan-converted into an adequate resolution level, there are provided an ultrasonic diagnostic system and method applicable to a wireless communication terminal with various resolution levels.

[Brief Description of Drawings]

15 **[0026]**

FIG. 1 is a block diagram schematically illustrating a conventional ultrasonic diagnostic system.

FIG. 2 is a view of a conventional ultrasonic diagnostic system used in a clinic.

20 FIG. 3 is a block diagram of an ultrasonic diagnostic system applicable to a wireless communication terminal with various resolution levels according to an embodiment of the present invention.

FIG. 4 is a flowchart illustrating of a process of generating a transmission packet by sampling according to a transmission volume as an embodiment.

25 FIG. 5 is a view illustrating a packet structure when a data transmission/reception portion 230 transmits resolution information.

FIG. 6 is a flowchart of an ultrasonic diagnostic method applicable to a wireless communication terminal with various resolution levels according to an embodiment of the present invention.

[Mode for Invention]

30 **[0027]** Embodiments of the present invention are provided to more completely explain the present invention to one of ordinary skill in the art and following embodiments may be modified into various other forms and the scope of the present invention is not limited thereto. The embodiments are provided to make the disclosure full and complete and to completely convey the concept to those skilled in the art.

35 **[0028]** The terms are used herein only to explain particular embodiments but do not limit the present invention. As used herein, singular expressions, unless contextually defined otherwise, may include plural expressions. Also, the terms "comprise" and/or "comprising" are used herein to specify the present of stated forms, numbers, steps, operations, members, elements, and/or groups thereof but do not preclude the presence or addition of one or more other forms, numbers, operations, members, elements and/or groups thereof. As used herein, the term "and/or" includes any and all combinations or one of a plurality of associated listed items.

40 **[0029]** It should be understood that although the terms "first", "second", etc. are used herein to describe various members, areas, layers, and/or portions, these members, areas, layers and/or portions are not limited by these terms. These terms do not mean particular order, top and bottom, or ratings but are used only to distinguish one member, area, or portion from another member, area, or portion. Accordingly, a first member, area, or portion which will be described below may be referred to as a second member, area, or portion without departing from the scope of the present invention.

45 **[0030]** Hereinafter, exemplary embodiments of the present invention will be described in detail with reference to the attached drawings.

[0031] FIG. 3 is a block diagram of an ultrasonic diagnostic system applicable to a wireless communication terminal with various resolution levels according to an embodiment of the present invention.

50 **[0032]** As shown in the drawings, the ultrasonic diagnostic system applicable to a wireless communication terminal with various resolution levels according to the embodiment of the present invention includes an ultrasonic diagnostic apparatus 100 and a wireless communication terminal 200 which transmit and receive ultrasonic image signals through wireless communication.

[0033] The ultrasonic diagnostic apparatus 100 may form scan data using frame data obtained from an ultrasonic probe 110 to correspond to a resolution level of a display screen of the wireless communication terminal 200 and to have an optimal bandwidth adequate for data transmission.

55 **[0034]** Also, the wireless communication terminal 200 may receive the scan data from the ultrasonic diagnostic apparatus 100 and may scan-convert the scan data into an ultrasonic image adequate for a resolution level of its own display.

[0035] In more detail, the ultrasonic diagnostic apparatus 100 may include the ultrasonic probe 110, a beam former

120, a resolution information reception portion 130, a scan data resolution database (DB) 140, a scan data generation portion 150, and a scan data transmission portion 160.

[0036] The ultrasonic probe 110 may transmit an ultrasonic signal to an object and may receive an echo signal reflected from the object.

[0037] Also, the beam former 120 may collect the echo signal reflected from the ultrasonic probe 110 and may generate frame data.

[0038] The resolution information reception portion 130 may receive resolution information from the wireless communication terminal 200.

[0039] Following Table 1 shows a type of a wireless communication terminal with various resolution levels.

[Table 1]

Operating system	Resolution	Product names
IOS	320×480	iPhone 3
	640×960	iPhone 4
	640×1136	iPHone 5
	768×1024	iPad 1, iPad 2, iPad mini
	1536×2048	iPad 3, iPad 4
Android	480×800	Galaxy S, Galaxy S2, Nexus S, HTC desired Hd
	800×1280	Galaxy Tab 10.1, Galaxy Note 1, Nexus 7
	720×1280	Galaxy S3, Galaxy S2 HD, Galaxy Note 2, Optimus G
	1200×1920	Nexus 7 (2013)
	1080×1920	G2, Galaxy S4, Galaxy Note 3

[0040] As shown in Table 1, a wireless communication terminal applicable to the embodiment of the present invention may have various resolution levels.

[0041] Accordingly, when the ultrasonic diagnostic apparatus 100 transmits an ultrasonic image to the wireless communication terminal 200, to prevent a distortion of an ultrasonic image signal, it is necessary to transmit an ultrasonic image with a resolution level higher than the resolution information received at the resolution information reception portion 130.

[0042] Meanwhile, scan data capable of corresponding to the resolution information of the wireless communication terminal with various resolution levels and increasing efficiency of a bandwidth while wireless communication is performed may be set and mapped in advance and stored in the scan data resolution DB 140.

[0043] Following Table 2 shows a bandwidth (Mbits/sec) used according to a volume of scan data transmitted through wireless communication.

[Table 2]

Volume of scan data	Bandwidth (Mbits/sec)
4K BYTE	120
2K BYTE	60
1K BYTE	30

[0044] As shown in Table 2, an occupied transmission bandwidth may vary according to the volume of the scan data.

[0045] Here, it is indicated that when the volume of the scan data is 4K bytes, pixel information of an ultrasonic image transmitted from an ultrasonic diagnostic apparatus to a wireless communication terminal through wireless communication is about 4,000 pieces.

[0046] For example, it may be known that since iPhone 4 with resolution of 640×960 in Table 1 has just scan data of 1K bytes, when the scan data of 4K bytes is transmitted, pixel information of about 3000 pieces is not used and abandoned. Here, referring to Table 2 for a transmission bandwidth, transmission bandwidths are occupied more than necessary, thereby reducing efficiency.

[0047] Accordingly, like the embodiment of the present invention, when the scan data resolution DB 140 in which scan

data is set and mapped in advance is used, it is possible to efficiently utilize the transmission bandwidth.

[0048] Following Table 3 shows a scan and mapped embodiment in the scan data resolution DB 140.

[Table 3]

Volume of scan data	Supported Resolution		
4K BYTE	1200×1920	1080×1920	1536×2048
2K BYTE	800×1280	720×1280	768×1024
1K BYTE	480×800	640×960	640×1136

[0049] The scan data generation portion 150 may compare mapping information of the scan data resolution DB 140 and generate scan data to be transmitted to the wireless communication terminal from the frame data using the resolution information received at the resolution information reception portion 130 from the wireless communication terminal 200 according to the embodiment of Table 3.

[0050] That is, as described above, in the case of iPhone 4 with resolution of 640×960, the scan data generation portion 150 may generate scan data of 1K which supports it.

[0051] FIG. 4 is a flowchart illustrating a process of generating a transmission packet by sampling according to a transmission volume as an embodiment.

[0052] As shown in the drawings, according to the embodiment of the present invention, a transmission packet may be generated and transmitted while the volume of total data is adjusted according to the volume of scan data.

[0053] As described above, the ultrasonic diagnostic apparatus 100 may transmit scan data generated by the scan data generation portion 150 using the scan data transmission portion 160 shown in FIG. 3.

[0054] Also, the wireless communication terminal 200 of the ultrasonic diagnostic system applicable to a wireless communication terminal with various resolution levels according to the embodiment of the present invention includes a display portion 210, a resolution information generation portion 220, a data transmission/reception portion 230, a scan-conversion resolution database 240, an application control portion 250, and a scan-conversion portion 260.

[0055] In more detail, the display portion 210 may include a display screen with various resolution levels as described above to display an ultrasonic image according to a type of a wireless communication terminal and may be provided at one of wireless communication terminals such as a personal computer (PC), a smart phone, a tablet type device, a pad type device, personal digital assistants (PDA), etc. connected through wireless communication.

[0056] The resolution information generation portion 220 may generate resolution information corresponding to the display screen of the display portion 210.

[0057] In the embodiment of the present invention, physical resolution information of the display screen may be obtained using a device driver of the display portion 210.

[0058] Here, including the resolution information generation portion 220, the scan-conversion resolution DB 240 and the application control portion 250 which will be described below may be embodied as independent application programs installed in a wireless communication terminal.

[0059] Also, the data transmission/reception portion 230 may perform wireless communication with the ultrasonic diagnostic apparatus 100 and transmit and receive the resolution information generated by the resolution information generation portion 220 of the wireless communication terminal and the scan data of the ultrasonic diagnostic apparatus 100.

[0060] FIG. 5 is a view illustrating a packet structure when a data transmission/reception portion 230 transmits resolution information.

[0061] A packet header may indicate a packet for data communication and may store a total volume of the packet. A command may indicate an operation command to be performed using the packet or a response for the command. A body may store data corresponding to the command or the response.

[0062] Meanwhile, the scan-conversion resolution DB 240 shown in FIG. 3 may store a size of an ultrasonic image capable of being scan-converted corresponding to the resolution information generated by the resolution information generation portion 220 of FIG. 3 which is set and mapped in advance.

[0063] Following Table 4 shows a set and mapped embodiment in the scan-conversion resolution DB 240.

[Table 4]

Volume of scan data	Supported Resolution of Wireless communication terminal		
1080×1080	1200×1920	1080×1920	1536×2048
720×720	800×1280	720×1280	768×1024

(continued)

Volume of scan data	Supported Resolution of Wireless communication terminal		
640×640	480×800	640×960	640×1136

5

[0064] As shown in Table 4, it may be known that sizes of ultrasonic images vary according to supported resolution levels of wireless communication terminals.

10

[0065] Accordingly, the application control portion 250 of the wireless communication terminal 200 may map an ultrasonic image corresponding to resolution information of the display screen of the display portion 210 using the scan-conversion resolution DB 240.

15

[0066] Next, the scan-conversion portion 260 may form an ultrasonic image adequate for resolution supported by the display screen by performing scan conversion on the scan data received from the ultrasonic diagnostic apparatus 100 using mapping information obtained from the application control portion 250.

20

[0067] As described above, the ultrasonic diagnostic system applicable to a wireless communication terminal with various resolution levels according to the embodiment of the present invention may increase efficiency of a transmission/reception bandwidth because the ultrasonic diagnostic apparatus 100 forms and transmits frame data obtained from the ultrasonic probe 110 as scan data corresponding to the resolution of the wireless communication terminal 200 and may be applied to the wireless communication terminal 200 with various resolution levels because the wireless communication terminal 200 may scan-convert the scan data received from the ultrasonic diagnostic apparatus 100 into an ultrasonic image adequate for the display screen with various resolution levels.

25

[0068] FIG. 6 is a flowchart of an ultrasonic diagnostic method applicable to a wireless communication terminal with various resolution levels according to an embodiment of the present invention.

[0069] Referring to FIG. 6, a diagnostic method of the ultrasonic diagnostic system described with reference to FIG. 3 will be described as follows.

30

[0070] As shown in the drawing, the diagnostic method of the ultrasonic diagnostic system applicable to a wireless communication terminal with various levels according to the embodiment of the present invention includes generating frame data (S10), generating resolution information (S20), transmitting the resolution information (S30), generating scan data (S40), transmitting the scan data (S50), scan-converting the scan data into an ultrasonic image (S60), and displaying the ultrasonic image on a display screen (S70).

35

[0071] In more detail, the generating of the frame data (S10) is a first operation in which the beam former 120 which forms the ultrasonic diagnostic apparatus 100 of FIG. 3 generates the frame data using an echo signal collected by the ultrasonic probe 110.

[0072] Next, the generating of the resolution information (S20) may be an operation of performing one function of an application program independently executed by the wireless communication terminal 200 of FIG. 3.

40

[0073] That is, the generating of the resolution information (S20) is a second operation in which the resolution information generation portion 220 of FIG. 3 requests display information from an exclusive operating system of the wireless communication terminal 200, a resolution level of the display screen is obtained through a device driver of the operating system, and then the resolution information is generated by providing the resolution level to the application program again.

45

[0074] Next, the transmitting of the resolution information (S30) is a third operation in which the resolution information obtained in the second operation using the data transmission/reception portion 230 of FIG. 3 which forms the wireless communication terminal 200 and the resolution information reception portion 130 of FIG. 3 which forms the ultrasonic diagnostic apparatus 100 is transmitted from the wireless communication terminal 200 to the ultrasonic diagnostic apparatus 100.

50

[0075] Also, the generating of the scan data (S40) is a fourth operation in which the resolution information of the wireless communication terminal 200 obtained in the second operation is compared with mapping information of the scan data resolution DB 140 of FIG. 3 and the frame data generated by the beam former 120 of FIG. 3 is generated as scan data to be transmitted to the wireless communication terminal according to the mapping information.

[0076] After that, the transmitting of the scan data (S50) is a fifth operation in which the scan data is transmitted from the ultrasonic diagnostic apparatus 100 to the wireless communication terminal 200 through the scan data transmission portion 160 of the ultrasonic diagnostic apparatus 100 of FIG. 3 and the data transmission/reception portion 230 of the wireless communication terminal 200.

55

[0077] Meanwhile, in the embodiment of the present invention, as a wireless communication method performed between the ultrasonic diagnostic apparatus 100 and the wireless communication terminal 200 in the third operation (S30) and the fifth operation (S50), one of Bluetooth, a wireless universal serial bus (USB), a wireless local area network (LAN), wireless fidelity (WiFi), Zigbee, and an infrared data association (IrDA).

[0078] Also, the scan-converting of the scan data into the ultrasonic image (S60) is a sixth operation in which the ultrasonic image corresponding to the resolution information is mapped by the application control portion 250 which

forms the wireless communication terminal 200 referring to the scan-conversion resolution DB 240 and then the scan data received from the ultrasonic diagnostic apparatus 100 is scan-converted into an ultrasonic image adequate for resolution information of the display screen by the scan-conversion portion 260.

[0079] Next, the ultrasonic image on which scan-conversion is completed may be displayed by the display portion 210.

[0080] Hereinafter, an example of an ultrasonic diagnostic apparatus according to one embodiment of the present invention will be described.

[0081] The ultrasonic diagnostic apparatus according to one embodiment of the present invention performs receiving resolution information of a terminal wirelessly connected and operating while interconnected with the ultrasonic diagnostic apparatus from the terminal, determining scan data generated using the resolution information received from the terminal into a volume adequate for the resolution information using a setting table and a method of sampling or interpolation, and generating transmission data or a packet with respect to the ultrasonic image according to the determination and transmitting it to the terminal.

[0082] Hereinafter, an example of a terminal interconnected with the ultrasonic diagnostic apparatus according to one embodiment of the present invention will be described.

[0083] There are operations of requesting resolution information with respect to the terminal from the ultrasonic diagnostic apparatus; transmitting the resolution information of the terminal to the ultrasonic diagnostic apparatus according to the request; receiving ultrasonic image data from the ultrasonic diagnostic apparatus; and generating an ultrasonic image from the received ultrasonic image data using an image processor.

[0084] As described above, according to the embodiments of the present invention, since frame data formed by a beam former of an ultrasonic diagnostic apparatus is formed as scan data corresponding to a resolution level of a wireless communication terminal and then transmitted to the wireless communication terminal, a transmission/reception bandwidth may be efficiently utilized.

[0085] Also, since the scan data transmitted from the ultrasonic diagnostic apparatus may be independently scan-converted into an adequate resolution level at the wireless communication terminal, there are provided an ultrasonic diagnostic system and method applicable to wireless communication terminals with various resolution levels.

[0086] While the present invention has been described in detail, it should be known that the embodiments described above are only exemplary and not limitative and it will be understood that various changes in form and details may be made therein without departing from the scope of the present invention as defined by the following claims.

Claims

1. An ultrasonic diagnostic system comprising an ultrasonic diagnostic apparatus (100) and a wireless communication terminal (200) including a display screen with various resolution levels, comprising:

the ultrasonic diagnostic apparatus (100) configured to convert frame data obtained by collecting an echo signal at an ultrasonic probe (110) into scan data corresponding to a resolution level of the display screen of the wireless communication terminal (200); and

the wireless communication terminal (200) configured to receive the scan data from the ultrasonic diagnostic apparatus (100) and scan-convert the scan data into an ultrasonic image adequate for the resolution level of the display screen thereof;

the ultrasonic diagnostic apparatus (100) comprising:

an ultrasonic probe (110) configured to transmit an ultrasonic signal to an object and receive an echo signal reflected by the object;

a beam former (120) configured to generate frame data by collecting the echo signal reflected from the ultrasonic probe;

a resolution information reception portion (130) configured to receive resolution information from the wireless communication terminal (200);

a scan data resolution database, DB, (140) in which scan data capable of corresponding to the resolution information of the wireless communication terminal with various resolution levels and increasing efficiency of a bandwidth while performing wireless communication is stored;

a scan data generation portion (150) configured to compare the resolution information received by the resolution information reception portion (130) with mapping information of the scan data resolution DB (140) and generate scan data to be transmitted to the wireless communication terminal (200) using the frame data; and

a scan data transmission portion (160) configured to transmit the scan data generated by the scan data generation portion (150) to the wireless communication terminal (200); and

the wireless communication terminal (200) comprising:

a display portion (210) configured to display an ultrasonic image;
 a resolution information generation portion (220) configured to generate resolution information corresponding to a display screen of the display portion (210);
 a data transmission/reception portion (230) configured to transmit and receive the resolution information and scan data by performing wireless communication with the ultrasonic diagnostic apparatus (100);
 a scan-conversion resolution DB (240) in which a size of an ultrasonic image capable of being scan-converted corresponding to the resolution information, which is set and mapped in advance, is stored;
 an application control portion (250) configured to map an ultrasonic image corresponding to the resolution information of the display screen using the scan-conversion resolution DB (240); and
 a scan-conversion portion (260) configured to scan-convert the scan data received from the ultrasonic diagnostic apparatus (100) into an ultrasonic image adequate for a resolution level of the display screen.

2. A displaying method of an ultrasonic image using an ultrasonic diagnostic system comprising an ultrasonic diagnostic apparatus (100) which forms scan data corresponding to a resolution level of a display screen of a wireless communication terminal (200) using frame data obtained by collecting an echo signal from an ultrasonic probe and the wireless communication terminal which receives the scan data from the ultrasonic diagnostic apparatus and scan-convert the scan data into an ultrasonic image adequate for the resolution level of the display screen, the method comprising:

a first operation of generating the frame data, by a beam former (120), by collecting the echo signal of the ultrasonic probe (110);
 a second operation of generating resolution information of the display screen, by a resolution generation portion (130) of the wireless communication terminal (200), using a device driver;
 a third operation of transmitting the resolution information from the wireless communication terminal (200) to the ultrasonic diagnostic apparatus (100) through a data transmission/reception portion (230) of the wireless communication terminal and a resolution information reception portion (130) of the ultrasonic diagnostic apparatus;
 a fourth operation of comparing the resolution information of the wireless communication terminal with mapping information of a scan data resolution DB (140) and then generating scan data to be transmitted to the wireless communication terminal using the frame data generated by the beam former according to the mapping information;
 a fifth operation of transmitting the scan data from the ultrasonic diagnostic apparatus to the wireless communication terminal through a scan data transmission portion (160) of the ultrasonic diagnostic apparatus and the data transmission/reception (230) of the wireless communication terminal;
 a sixth operation of mapping an ultrasonic image corresponding to the resolution information, by an application control portion (250), by referring to a scan-conversion resolution DB (240) and then scan-converting the scan data received from the ultrasonic diagnostic apparatus, by a scan-conversion portion (260), into an ultrasonic image adequate for the resolution information of the display screen; and
 a seventh operation of displaying the ultrasonic image on which scan conversion is completed by a display portion (210).

Patentansprüche

1. Ultraschalldiagnosesystem, umfassend eine Ultraschalldiagnosevorrichtung (100) und ein Drahtloskommunikationsendgerät (200) mit einem Bildschirm mit verschiedenen Auflösungsgraden, umfassend:

die Ultraschalldiagnosevorrichtung (100), die konfiguriert ist, um Rahmendaten, die durch Sammeln eines Echosignals an einer Ultraschallsonde (110) erhalten werden, in Scandaten umzuwandeln, die einem Auflösungsgrad des Anzeigebildschirms des Drahtloskommunikationsendgerätes (200) entsprechen; und
 das Drahtloskommunikationsendgerät (200), das konfiguriert ist, um die Scandaten von der Ultraschalldiagnosevorrichtung (100) zu empfangen und die Scandaten in ein Ultraschallbild scanmäßig zu konvertieren, das für den Auflösungsgrad des Bildschirms davon angemessen ist;
 wobei die Ultraschalldiagnosevorrichtung (100) umfasst:

eine Ultraschallsonde (110), die konfiguriert ist, um ein Ultraschallsignal zu einem Gegenstand zu übertra-

gen und ein vom Gegenstand reflektiertes Echosignal zu empfangen;
 einen Strahlformer (120), der konfiguriert ist, um Rahmendaten durch Sammeln des von der Ultraschallsonde reflektierten Echosignals zu erzeugen;
 einen Auflösungsinformationsempfangsabschnitt (130), der konfiguriert ist, um Auflösungsinformationen von dem Drahtloskommunikationsendgerät (200) zu empfangen;
 eine Scandatenauflösungsdatenbank DB (140), in der Scandaten gespeichert sind, die in der Lage sind, den Auflösungsinformationen des Drahtloskommunikationsendgeräts mit verschiedenen Auflösungsgraden zu entsprechen und die Effizienz einer Bandbreite während der Durchführung einer drahtlosen Kommunikation zu erhöhen;
 einen Scandatenerzeugungsabschnitt (150), der konfiguriert ist, um die vom Auflösungsinformationsempfangsabschnitt (130) empfangenen Auflösungsinformationen mit Abbildungsinformationen der Scandatenauflösung DB (140) zu vergleichen und Scandaten zu erzeugen, die unter Verwendung der Rahmendaten an das Drahtloskommunikationsendgerät (200) zu übertragen sind; und
 einen Scandatenübertragungsabschnitt (160), der konfiguriert ist, um die durch den Scandatenerzeugungsabschnitt (150) erzeugten Scandaten an das Drahtloskommunikationsendgerät (200) zu übertragen; und wobei das Drahtloskommunikationsendgerät (200) umfasst:

einen Anzeigeabschnitt (210), der konfiguriert ist, um ein Ultraschallbild anzuzeigen;
 einen Auflösungsinformationserzeugungsabschnitt (220), der konfiguriert ist, um Auflösungsinformationen zu erzeugen, die einem Anzeigebildschirm des Anzeigeabschnitts (210) entsprechen;
 einen Datenübertragungs-/Empfangsabschnitt (230), der konfiguriert ist, um die Auflösungsinformationen und Scandaten zu senden und zu empfangen, indem er eine drahtlose Kommunikation mit der Ultraschalldiagnosevorrichtung (100) durchführt;
 eine Scankonvertierungsauflösung DB (240), in der eine Größe eines scanmäßig konvertierten Ultraschallbildes entsprechend der Auflösungsinformationen, die im Voraus eingestellt und abgebildet werden, gespeichert ist;
 einen Anwendungssteuerungsabschnitt (250), der konfiguriert ist, um ein Ultraschallbild abzubilden, das den Auflösungsinformationen des Anzeigebildschirms entspricht, unter Verwendung der Scankonvertierungsauflösung DB (240); und
 einen Scankonvertierungsabschnitt (260), der konfiguriert ist, um die von der Ultraschalldiagnosevorrichtung (100) empfangenen Scandaten in ein Ultraschallbild scanmäßig zu konvertieren, das für einen Auflösungsgrad des Anzeigebildschirms ausreichend ist.

2. Anzeigeverfahren eines Ultraschallbildes unter Verwendung eines Ultraschalldiagnosesystems, umfassend eine Ultraschalldiagnosevorrichtung (100), die Scandaten bildet, die einem Auflösungsgrad eines Anzeigebildschirms eines Drahtloskommunikationsendgerätes (200) entsprechen, unter Verwendung von Rahmendaten, die durch Sammeln eines Echosignals von einer Ultraschallsonde erhalten werden, und des Drahtloskommunikationsendgerätes, das die Scandaten von der Ultraschalldiagnosevorrichtung empfängt und die Scandaten in ein Ultraschallbild scanmäßig konvertiert, das für den Auflösungsgrad des Anzeigebildschirms ausreichend ist, wobei das Verfahren umfasst:

einen ersten Vorgang zum Erzeugen der Rahmendaten durch einen Strahlformer (120) durch Sammeln des Echosignals der Ultraschallsonde (110);
 einen zweiten Vorgang zum Erzeugen von Auflösungsinformationen des Anzeigebildschirms durch einen Auflösungserzeugungsabschnitt (130) des Drahtloskommunikationsendgerätes (200) unter Verwendung eines Gerätetreibers;
 einen dritten Vorgang zum Übertragen der Auflösungsinformationen vom Drahtloskommunikationsendgerät (200) an die Ultraschalldiagnosevorrichtung (100) durch einen Datenübertragungs-/Empfangsabschnitt (230) des Drahtloskommunikationsendgerätes und einen Auflösungsinformationsempfangsabschnitt (130) der Ultraschalldiagnosevorrichtung;
 einen vierten Vorgang zum Vergleichen der Auflösungsinformationen des Drahtloskommunikationsendgerätes mit Abbildungsinformationen einer Scandatenauflösung DB (140) und anschließendem Erzeugen von Scandaten, die an das Drahtloskommunikationsendgerät zu übertragen sind, unter Verwendung der vom Strahlformer erzeugten Rahmendaten gemäß den Abbildungsinformationen;
 einen fünften Vorgang zum Übertragen der Scandaten von dem Ultraschalldiagnosegerät an das Drahtloskommunikationsendgerät durch einen Scandatenübertragungsabschnitt (160) der Ultraschalldiagnosevorrichtung und das Senden/Empfangen (230) von Daten des Drahtloskommunikationsendgerätes;
 einen sechsten Vorgang zum Abbilden eines Ultraschallbildes, das den Auflösungsinformationen entspricht,

durch einen Anwendungssteuerabschnitt (250), durch Bezugnahme auf eine Scankonvertierungsauflösung DB (240) und dann durch scanmäßiges Konvertieren der von der Ultraschalldiagnosevorrichtung empfangenen Scandaten durch einen Scankonvertierungsabschnitt (260) in ein Ultraschallbild, das für die Auflösungsinformationen des Anzeigebildschirms geeignet ist; und
5 einen siebten Vorgang zum Anzeigen des Ultraschallbildes, auf dem die scanmäßige Konvertierung durch einen Anzeigebereich (210) abgeschlossen ist.

Revendications

- 10
1. Système de diagnostic par ultrasons comprenant un appareil de diagnostic par ultrasons (100) et un terminal de communication sans fil (200) incluant un écran d'affichage avec divers niveaux de résolution, comprenant :

15 l'appareil de diagnostic à ultrasons (100) qui est configuré pour convertir des données de trame obtenues en recueillant un signal d'écho au niveau d'une sonde à ultrasons (110) en des données de numérisation correspondant à un niveau de résolution de l'écran d'affichage du terminal de communication sans fil (200) ; et le terminal de communication sans fil (200) qui est configuré pour recevoir les données de numérisation provenant de l'appareil de diagnostic à ultrasons (100) et convertir par numérisation les données de numérisation en une image ultrasonore adaptée au niveau de résolution de son écran d'affichage ;
20 l'appareil de diagnostic à ultrasons (100) comprenant :

une sonde à ultrasons (110) configurée pour transmettre un signal ultrasonore à un objet et recevoir un signal d'écho réfléchi par l'objet ;

25 un dispositif de formation de faisceau (120) configuré pour générer des données de trame en recueillant le signal d'écho réfléchi par la sonde à ultrasons ;

une partie de réception d'informations de résolution (130) configurée pour recevoir des informations de résolution du terminal de communication sans fil (200) ;

30 une base de données de résolution de données de numérisation, DB, (140) dans laquelle sont stockées des données de numérisation capables de correspondre aux informations de résolution du terminal de communication sans fil avec divers niveaux de résolution et une efficacité croissante d'une bande passante lors de l'exécution d'une communication sans fil ;

35 une partie de génération de données de numérisation (150) configurée pour comparer les informations de résolution reçues par la partie de réception d'informations de résolution (130) avec des informations de mappage de la base de données DB de résolution de données de numérisation (140) et générer des données de numérisation à transmettre au terminal de communication sans fil (200) en utilisant les données de trame ; et

40 une partie de transmission de données de numérisation (160) configurée pour transmettre les données de numérisation générées par la partie de génération de données de numérisation (150) au terminal de communication sans fil (200) ; et

le terminal de communication sans fil (200) comprenant :

une partie d'affichage (210) qui est configurée pour afficher une image ultrasonore ;

45 une partie de génération d'informations de résolution (220) qui est configurée pour générer des informations de résolution correspondant à un écran d'affichage de la partie d'affichage (210) ;

une partie d'émission/réception de données (230) qui est configurée pour émettre et recevoir les informations de résolution et données de numérisation en établissant une communication sans fil avec l'appareil de diagnostic à ultrasons (100) ;

50 une base de données DB de résolution de conversion par numérisation (240) dans laquelle est stockée une taille d'une image ultrasonore pouvant être convertie par numérisation correspondant aux informations de résolution qui sont définies et mappées à l'avance ;

une partie de commande d'application (250) configurée pour mapper une image ultrasonore correspondant aux informations de résolution de l'écran d'affichage en utilisant la base de données DB de résolution de conversion par numérisation (240) ; et

55 une partie de conversion par numérisation (260) configurée pour convertir par numérisation les données de numérisation reçues de l'appareil de diagnostic à ultrasons (100) en une image à ultrasons adaptée au niveau de résolution de l'écran d'affichage.

2. Procédé d'affichage d'une image ultrasonore utilisant un système de diagnostic à ultrasons comprenant un appareil

EP 3 138 500 B1

de diagnostic à ultrasons (100) qui forme des données de numérisation correspondant à un niveau de résolution d'un écran d'affichage d'un terminal de communication sans fil (200) en utilisant des données de trame obtenues en recueillant un signal d'écho à partir d'une sonde à ultrasons et le terminal de communication sans fil qui reçoit les données de numérisation provenant de l'appareil de diagnostic à ultrasons et convertit par numérisation les données de numérisation en une image à ultrasons adaptée au niveau de résolution de l'écran d'affichage, le procédé comprenant :

une première opération de génération des données de trame, par un dispositif de formation de faisceau (120), en recueillant le signal d'écho de la sonde à ultrasons (110) ;

une deuxième opération de génération d'informations de résolution de l'écran d'affichage, par une partie de génération de résolution (130) du terminal de communication sans fil (200), à l'aide d'un pilote de dispositif ;

une troisième opération de transmission des informations de résolution du terminal de communication sans fil (200) à l'appareil de diagnostic à ultrasons (100) via une partie d'émission/réception de données (230) du terminal de communication sans fil et une partie de réception d'informations de résolution (130) de l'appareil de diagnostic à ultrasons ;

une quatrième opération de comparaison des informations de résolution du terminal de communication sans fil avec les informations de mappage d'une base de données DB de résolution de données de numérisation (140), puis de génération des données de numérisation à transmettre au terminal de communication sans fil en utilisant les données de trame générées par le dispositif de formation de faisceau conformément aux informations de mappage ;

une cinquième opération de transmission des données de numérisation de l'appareil de diagnostic à ultrasons au terminal de communication sans fil par l'intermédiaire d'une partie de transmission de données de numérisation (160) de l'appareil de diagnostic à ultrasons et l'émission/réception de données (230) du terminal de communication sans fil ;

une sixième opération de mappage d'une image ultrasonore correspondant aux informations de résolution, par une partie de commande d'application (250), en se référant à une base de données de résolution DB de conversion par numérisation (240) puis en convertissant par numérisation les données de numérisation reçues de l'appareil de diagnostic à ultrasons, par une partie de conversion par numérisation (260), en une image ultrasonore adaptée aux informations de résolution de l'écran d'affichage ; et

une septième opération d'affichage de l'image ultrasonore, sur laquelle la conversion par numérisation est achevée, par une partie d'affichage (210).

FIG. 1
(PRIOR ART)

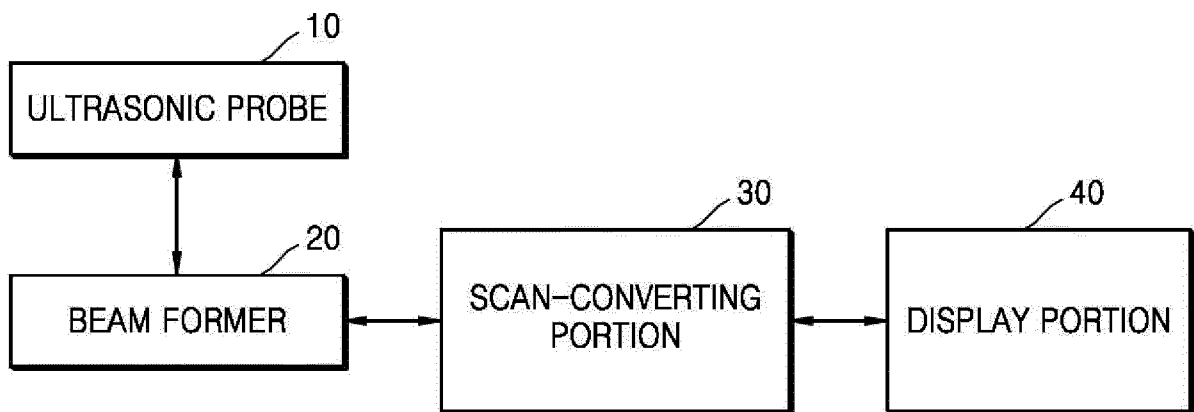

FIG. 2
(PRIOR ART)

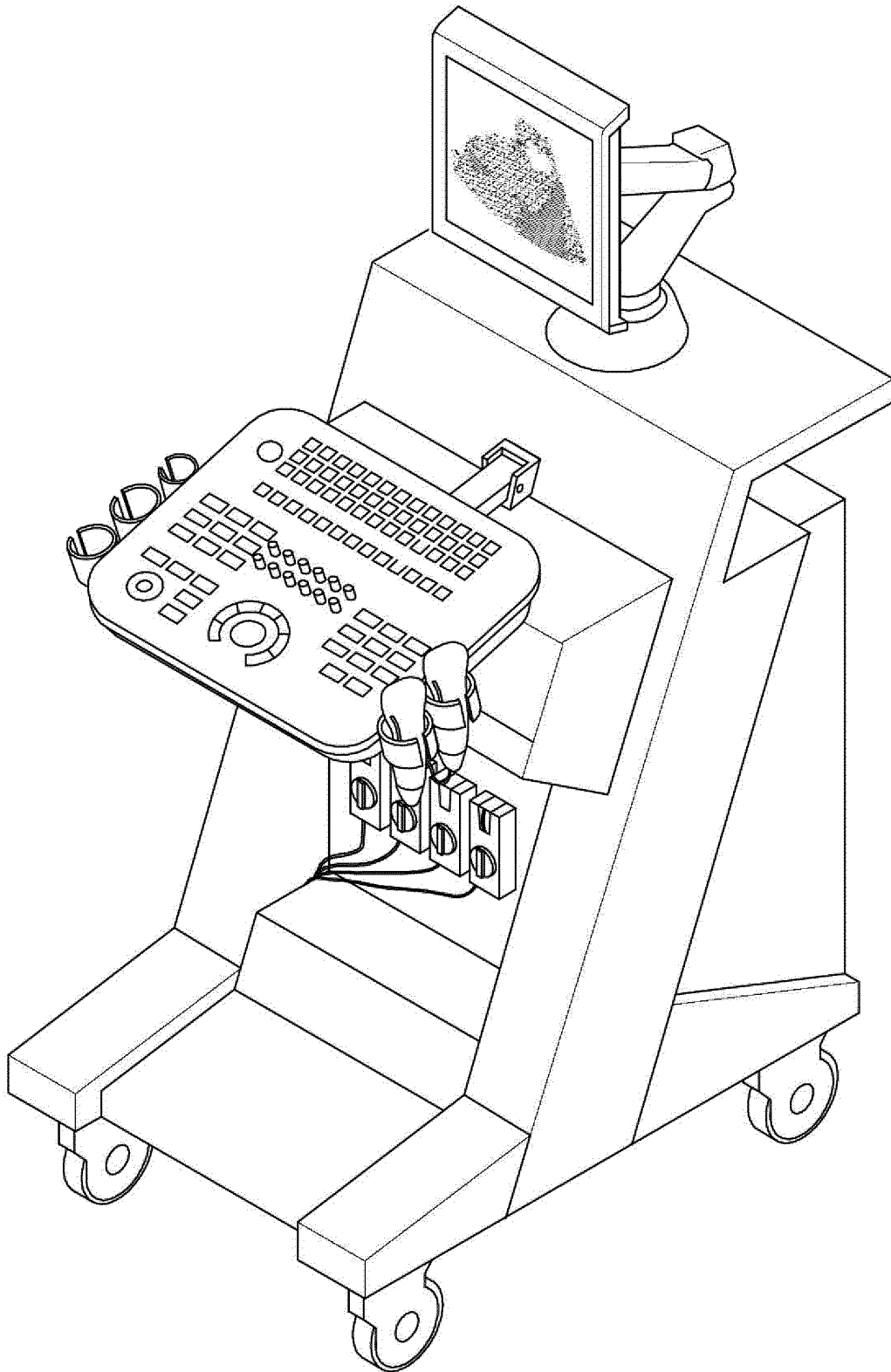

FIG. 3

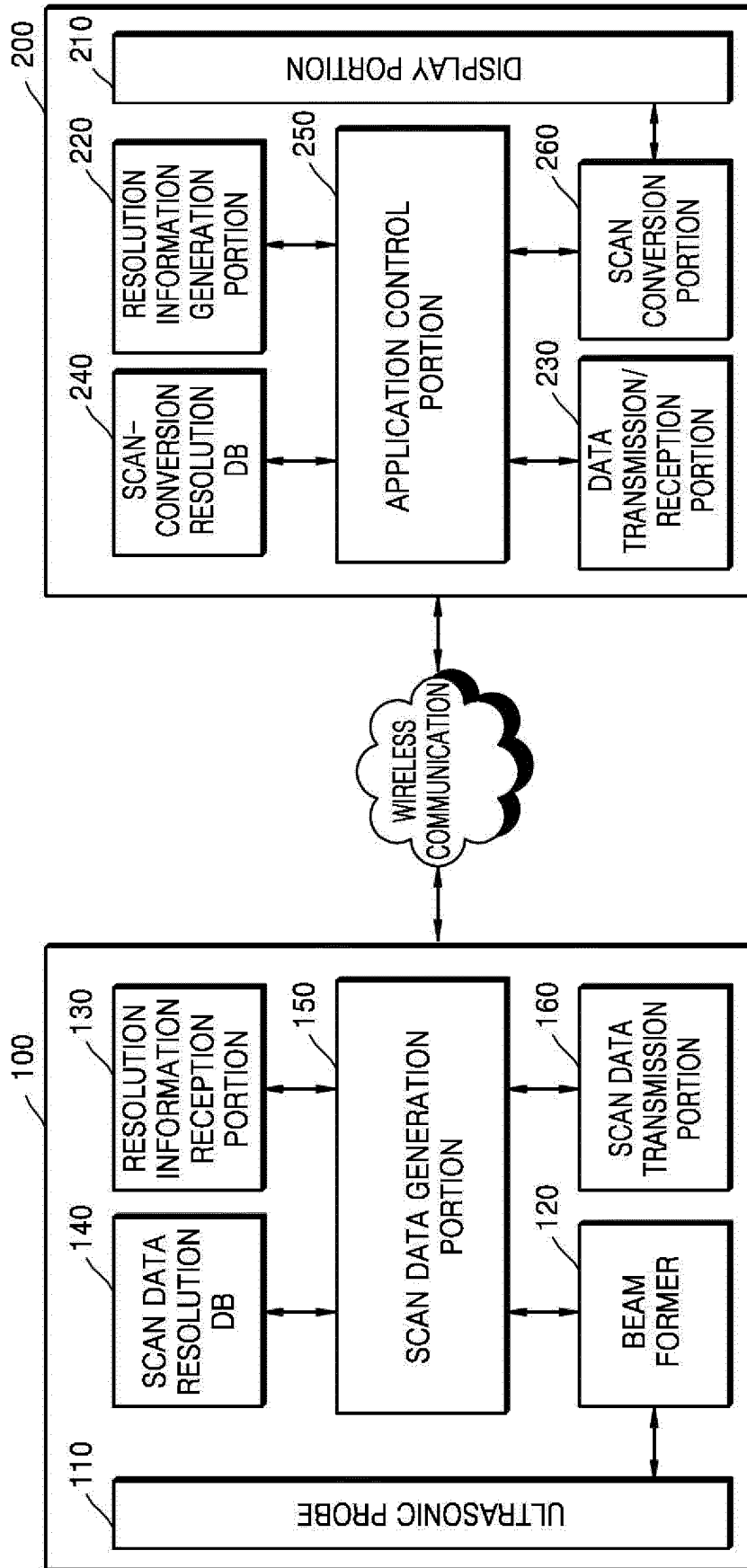

FIG. 4

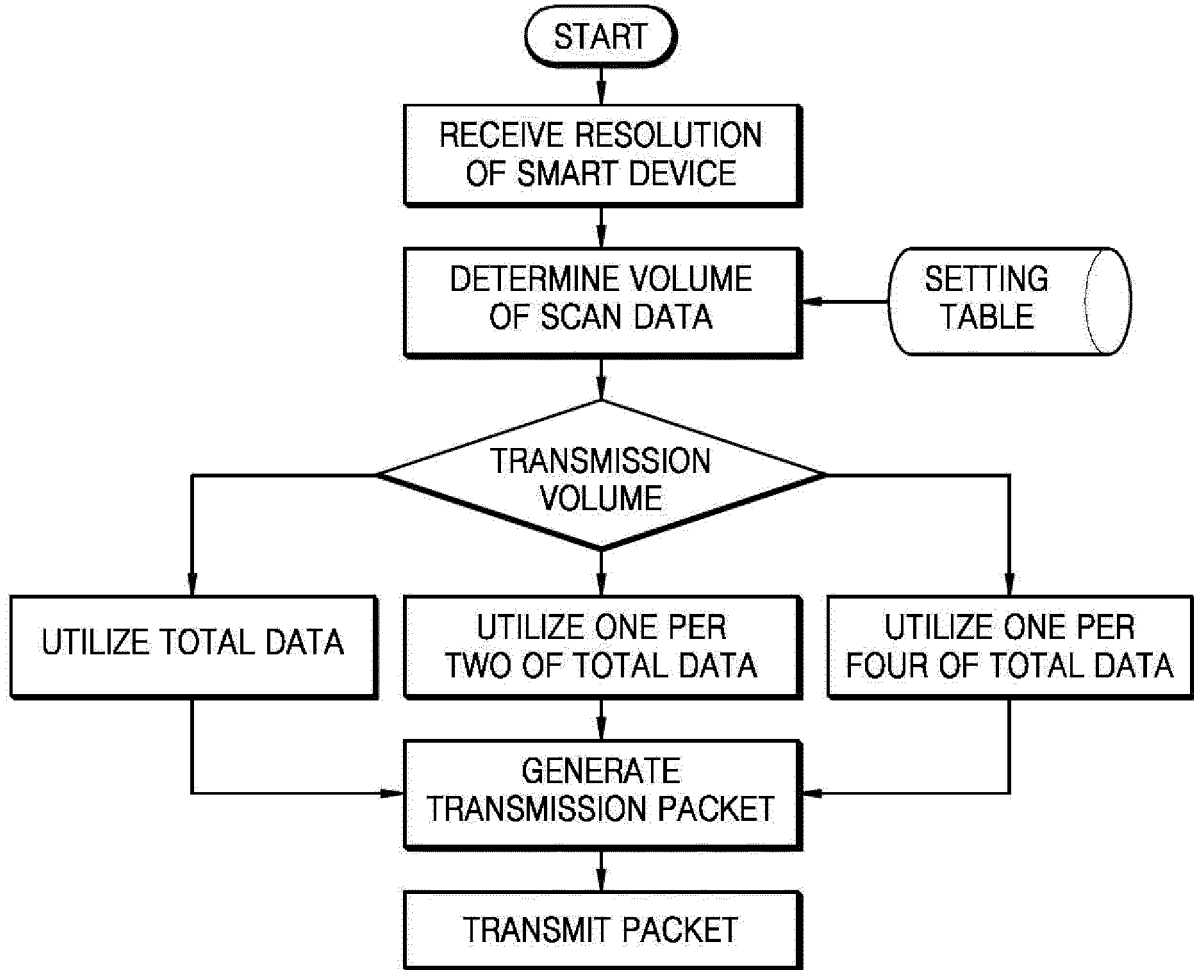

FIG. 5

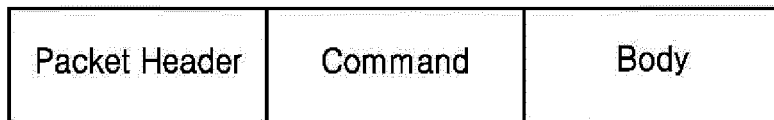
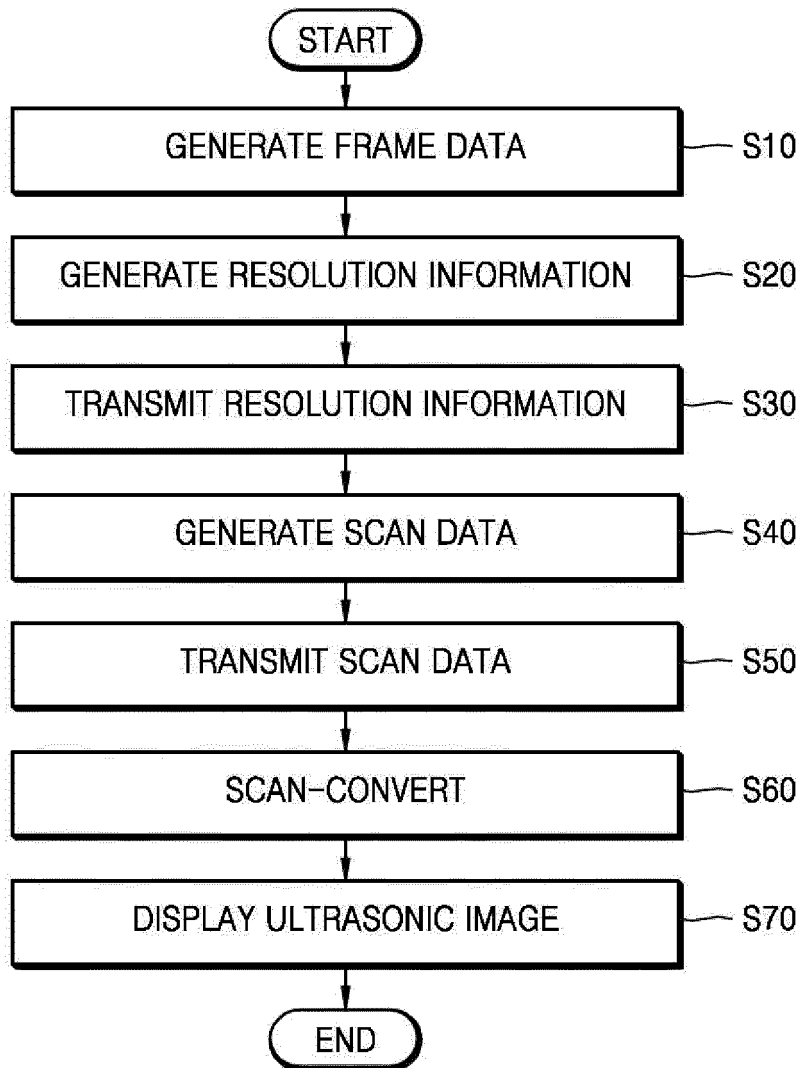

FIG. 6



REFERENCES CITED IN THE DESCRIPTION

This list of references cited by the applicant is for the reader's convenience only. It does not form part of the European patent document. Even though great care has been taken in compiling the references, errors or omissions cannot be excluded and the EPO disclaims all liability in this regard.

Patent documents cited in the description

- US 2008114245 A [0017]
- WO 2013118359 A [0018]

专利名称(译)	适用于具有各种分辨率等级的无线通信终端的超声波系统和方法		
公开(公告)号	EP3138500B1	公开(公告)日	2019-05-08
申请号	EP2015786419	申请日	2015-03-13
[标]申请(专利权)人(译)	和赛仑有限公司		
申请(专利权)人(译)	healcerion有限公司		
当前申请(专利权)人(译)	HEALCERION CO. , LTD.		
[标]发明人	RYU JEONG WON CHOUNG YOU CHAN CHUNG WOOK JIN		
发明人	RYU, JEONG WON CHOUNG, YOU CHAN CHUNG, WOOK JIN		
IPC分类号	A61B8/00 G01N29/24		
CPC分类号	A61B8/4411 A61B8/4427 A61B8/4433 A61B8/464 A61B8/54 A61B8/56 A61B8/00 G01N29/24 A61B8/14 A61B8/4472 A61B8/461 A61B8/5207 A61B8/565 G01N29/2481		
优先权	1020140050669 2014-04-28 KR		
其他公开文献	EP3138500A1 EP3138500A4		
外部链接	Espacenet		

摘要(译)

本发明涉及一种具有低功率模式的便携式超声波诊断装置及其执行方法，并且根据本发明的具有低功率模式的便携式超声波诊断装置包括：发射超声波的超声波探头向待检查对象发信号，然后接收从待检查对象反射的回波信号；波束形成器，其收集从超声波探头反射的回波信号，以产生帧数据；扫描转换单元，扫描并转换在波束形成器中产生的帧数据，以形成超声波图像；显示单元，具有显示屏，在该显示屏上显示扫描和转换的超声图像；如果在显示单元的超声图像中没有对图像进行超声诊断，则存储器用于在图像上存储图像数据；超声图像比较分析器，用于比较和分析显示单元的超声图像和存储在存储器中的图像数据；低功率模式控制单元，如果确定超声图像比较分析仪在显示单元上显示的超声图像是未进行超声诊断的超声图像，则使整个电路进入低功率模式出。

FIG. 1
(PRIOR ART)

