



(11) **EP 3 138 500 A1**

(12) **EUROPEAN PATENT APPLICATION**
published in accordance with Art. 153(4) EPC

(43) Date of publication:
08.03.2017 Bulletin 2017/10

(51) Int Cl.:
A61B 8/00 (2006.01) G01N 29/24 (2006.01)

(21) Application number: **15786419.0**

(86) International application number:
PCT/KR2015/002433

(22) Date of filing: **13.03.2015**

(87) International publication number:
WO 2015/167122 (05.11.2015 Gazette 2015/44)

(84) Designated Contracting States:
AL AT BE BG CH CY CZ DE DK EE ES FI FR GB GR HR HU IE IS IT LI LT LU LV MC MK MT NL NO PL PT RO RS SE SI SK SM TR
Designated Extension States:
BA ME
Designated Validation States:
MA

(72) Inventors:
• **RYU, Jeong Won**
Seoul 137-140 (KR)
• **CHOUNG, You Chan**
Seoul 122-807 (KR)
• **CHUNG, Wook Jin**
Seoul 135-950 (KR)

(30) Priority: **28.04.2014 KR 20140050669**

(74) Representative: **Groth & Co. KB**
P.O. Box 6107
102 32 Stockholm (SE)

(71) Applicant: **Healcerion Co. Ltd.**
SEOUL 152-848 (KR)

(54) **ULTRASONIC DIAGNOSTIC SYSTEM AND DIAGNOSTIC METHOD APPLICABLE TO WIRELESS COMMUNICATION TERMINAL HAVING VARIOUS RESOLUTION LEVELS**

(57) The present invention relates to a portable ultrasonic diagnostic device having a low power mode and a method for performing the same, and the portable ultrasonic diagnostic device having a low power mode, according to the present invention, comprises: an ultrasonic probe which transmits an ultrasonic signal to an object to be inspected, and then, which receives echo signals reflected from the object to be inspected; a beamformer which collects the echo signals reflected from the ultrasonic probe so as to generate frame data; a scan conversion unit which scans and converts the frame data generated in the beamformer so as to form ultrasonic images; a display unit provided with a display screen on

which the scanned and converted ultrasonic images are displayed; a memory for storing image data on an image if an ultrasonic diagnosis is not carried on the image among the ultrasonic images of the display unit; an ultrasonic image comparison analyzer for comparing and analyzing the ultrasonic images of the display unit and the image data stored in the memory; and a low power mode control unit for enabling the whole circuit to enter a low power mode if it is determined that an ultrasonic image displayed on the display unit by the ultrasonic image comparison analyzer is an ultrasonic image for which the ultrasonic diagnosis has not been carried out.

FIG. 3

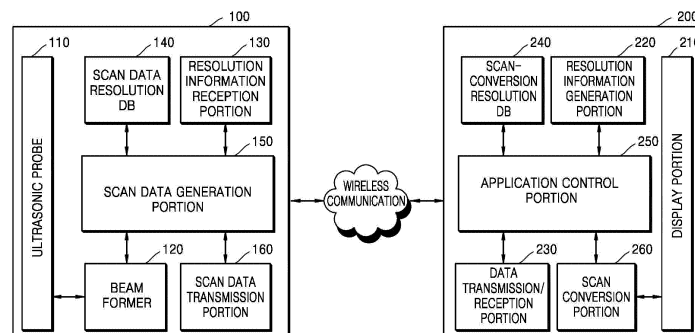

EP 3 138 500 A1

Description

[Technical Field]

5 **[0001]** The present invention relates to an ultrasonic diagnostic system and method applicable to a wireless communication terminal with various resolution levels, and more particularly, to an ultrasonic diagnostic system and method applicable to a wireless communication terminal with various resolution levels, capable of embodying resolution adequate for the wireless communication terminal with various resolution levels and efficiently utilizing a transmission/reception bandwidth at the same time.

10

[Background Art]

[0002] With noninvasive and nondestructive properties, ultrasonic diagnostic apparatuses are generally used in the medical field to obtain information of the inside of an object. Since it is possible to provide a high-resolution image of internal organizations of the object to a doctor with no surgical operations of directly incising and observing the object, ultrasonic diagnostic systems are very importantly used in the medical field.

15

[0003] Ultrasonic diagnostic apparatuses are systems which emit an ultrasonic signal from a body surface of an object toward a target portion inside the object, extract information from a reflected ultrasonic signal, and obtain an image of a section of soft tissue or a blood flow in a noninvasive manner.

20

[0004] Compared with other imaging diagnostic apparatuses such as X-ray inspection apparatuses, computerized tomography (CT) scanners, magnetic resonance image (MRI) scanners, and nuclear medicine inspection apparatuses, since having a small size, being cheap, being capable of displaying in real time, and having excellent safety without being exposed to X-rays, ultrasonic diagnostic systems described above are generally used to diagnose hearts, internal organs in an abdominal cavity, urinary systems, and genital organs.

25

[0005] FIG. 1 is a block diagram schematically illustrating an ultrasonic diagnostic system.

[0006] As shown in the drawing, the ultrasonic diagnostic system includes an ultrasonic probe 10, a beam former 20, a scan-converting portion 30, and a display portion 40.

30

[0007] The ultrasonic probe 10 transmits an ultrasonic signal to an object and forms a reception signal by receiving an echo signal reflected from the object. Also, the ultrasonic probe 10 includes at least one transducer element which operates to transduce an ultrasonic signal and an electric signal into each other.

35

[0008] The beam former 20 analog/digital-converts and time-delays the reception signal provided from the ultrasonic probe 10 considering a position and a focused point of each of the transducer elements and forms frame data by adding up time-delayed digital signals.

40

[0009] The scan-converting portion 30 generates an ultrasonic image by performing scan-conversion to display the frame data on a display screen of a display portion.

45

[0010] The display portion 40 displays scan-converted ultrasonic data as the ultrasonic image on the display screen.

[0011] FIG. 2 is a view of a conventional ultrasonic diagnostic system used in a clinic.

50

[0012] As shown in the drawing, since the conventional ultrasonic diagnostic system has a monitor for displaying to display an ultrasonic image which is fixedly mounted therein, the ultrasonic image is generated according to a certain resolution level.

55

[0013] Recently, it has been tried to perform ultrasonic diagnosis by connecting various wireless communication terminals such as a smart phone and a tablet personal computer to the ultrasonic diagnostic system through wireless communication.

60

[0014] However, since wireless communication terminals described above include a display with various resolution levels, it is necessary to adjust a resolution level to transmit an ultrasonic image with a resolution level different from that of a general ultrasonic diagnostic system to a wireless communication terminal.

65

[0015] In addition, when the wireless communication terminal includes a display portion with a resolution level lower than an ultrasonic image generated by the ultrasonic diagnostic system, it is impossible to efficiently utilize a transmission/reception bandwidth when the ultrasonic image generated by the general ultrasonic diagnostic system is transmitted to the wireless communication terminal.

70

[0016] Accordingly, a practical and applicable technology with respect to an ultrasonic diagnostic system capable of providing resolution adequate for a wireless communication terminal with various resolution levels and efficiently utilizing a transmission/reception bandwidth at the same time is urgently needed.

75

[Disclosure]

[Technical Problem]

5 **[0017]** The present invention provides an ultrasonic diagnostic system and method capable of providing resolution adequate for a wireless communication terminal with various resolution levels and efficiently utilizing a transmission/reception bandwidth at the same time.

[Technical Solution]

10 **[0018]** One aspect of the present invention provides an ultrasonic diagnostic system formed of an ultrasonic diagnostic apparatus and a wireless communication terminal and applicable to a wireless communication terminal with various resolution levels, including the ultrasonic diagnostic apparatus which converts frame data obtained by collecting an echo signal at an ultrasonic probe into scan data corresponding to a resolution level of a display screen of the wireless communication terminal and the wireless communication terminal which receives the scan data from the ultrasonic diagnostic apparatus and scan-converts the scan data into an ultrasonic image adequate for the resolution level of the display screen thereof.

15 **[0019]** The ultrasonic diagnostic apparatus may include an ultrasonic probe which transmits an ultrasonic signal to an object and receives an echo signal reflected by the object, a beam former which generates frame data by collecting the echo signal reflected from the ultrasonic probe, a resolution information reception portion which receives resolution information from the wireless communication terminal, a scan data resolution database (DB) in which scan data capable of corresponding to the resolution information of the wireless communication terminal with various resolution levels and increasing efficiency of a bandwidth while performing wireless communication, a scan data generation portion which compares the resolution information received by the resolution information reception portion with mapping information of the scan data resolution DB and generates scan data to be transmitted to the wireless communication terminal using the frame data, and a scan data transmission portion which transmits the scan data generated by the scan data generation portion to the wireless communication terminal.

20 **[0020]** The wireless communication terminal may include a display portion which displays an ultrasonic image, a resolution information generation portion which generates resolution information corresponding to a display screen of the display portion, a data transmission/reception portion which transmits and receives the resolution information and scan data by performing wireless communication with the ultrasonic diagnostic apparatus, a scan-conversion resolution DB in which a size of an ultrasonic image capable of being scan-converted corresponding to the resolution information, which is set and mapped in advance, is stored, an application control portion which maps an ultrasonic image corresponding to the resolution information of the display screen using the scan-conversion resolution DB, and a scan-conversion portion which scan-converts the scan data received from the ultrasonic diagnostic apparatus into an ultrasonic image adequate for a resolution level of the display screen.

25 **[0021]** Another aspect of the present invention provides a diagnostic method of an ultrasonic diagnostic system applicable to a wireless communication terminal with various resolution levels and including an ultrasonic diagnostic apparatus which forms scan data corresponding to a resolution level of a display screen of the wireless communication terminal using frame data obtained by collecting an echo signal from an ultrasonic probe and the wireless communication terminal which receives the scan data from the ultrasonic diagnostic apparatus and scan-convert the scan data into an ultrasonic image adequate for the resolution level of the display screen. The method includes a first operation of generating the frame data, by a beam former, by collecting the echo signal of the ultrasonic probe, a second operation of generating resolution information of the display screen, by a resolution generation portion of the wireless communication terminal, using a device driver, a third operation of transmitting the resolution information from the wireless communication terminal to the ultrasonic diagnostic apparatus through a data transmission/reception portion of the wireless communication terminal and a resolution information reception portion of the ultrasonic diagnostic apparatus, a fourth operation of comparing the resolution information of the wireless communication terminal with mapping information of a scan data resolution DB and then generating scan data to be transmitted to the wireless communication terminal using the frame data generated by the beam former according to the mapping information, a fifth operation of transmitting the scan data from the ultrasonic diagnostic apparatus to the wireless communication terminal through a scan data transmission portion of the ultrasonic diagnostic apparatus and the data transmission/reception of the wireless communication terminal, a sixth operation of mapping an ultrasonic image corresponding to the resolution information, by an application control portion, by referring to a scan-conversion resolution DB and then scan-converting the scan data received from the ultrasonic diagnostic apparatus, by a scan-conversion portion, into an ultrasonic image adequate for the resolution information of the display screen, and a seventh operation of displaying the ultrasonic image on which scan conversion is completed by a display portion.

[Advantageous Effects]

[0022] As described above, according to the embodiments of the present invention, since frame data formed by a beam former of an ultrasonic diagnostic apparatus is formed as scan data corresponding to a resolution level of a wireless communication terminal and then transmitted to the wireless communication terminal, a transmission/reception bandwidth may be efficiently utilized.

[0023] Also, since the scan data transmitted from the ultrasonic diagnostic apparatus may be independently scan-converted into an adequate resolution level, there are provided an ultrasonic diagnostic system and method applicable to a wireless communication terminal with various resolution levels.

[Brief Description of Drawings]

[0024]

FIG. 1 is a block diagram schematically illustrating a conventional ultrasonic diagnostic system.

FIG. 2 is a view of a conventional ultrasonic diagnostic system used in a clinic.

FIG. 3 is a block diagram of an ultrasonic diagnostic system applicable to a wireless communication terminal with various resolution levels according to an embodiment of the present invention.

FIG. 4 is a flowchart illustrating of a process of generating a transmission packet by sampling according to a transmission volume as an embodiment.

FIG. 5 is a view illustrating a packet structure when a data transmission/reception portion 230 transmits resolution information.

FIG. 6 is a flowchart of an ultrasonic diagnostic method applicable to a wireless communication terminal with various resolution levels according to an embodiment of the present invention.

[Mode for Invention]

[0025] Embodiments of the present invention are provided to more completely explain the present invention to one of ordinary skill in the art and following embodiments may be modified into various other forms and the scope of the present invention is not limited thereto. The embodiments are provided to make the disclosure full and complete and to completely convey the concept to those skilled in the art.

[0026] The terms are used herein only to explain particular embodiments but do not limit the present invention. As used herein, singular expressions, unless contextually defined otherwise, may include plural expressions. Also, the terms "comprise" and/or "comprising" are used herein to specify the present of stated forms, numbers, steps, operations, members, elements, and/or groups thereof but do not preclude the presence or addition of one or more other forms, numbers, operations, members, elements and/or groups thereof. As used herein, the term "and/or" includes any and all combinations or one of a plurality of associated listed items.

[0027] It should be understood that although the terms "first", "second", etc. are used herein to describe various members, areas, layers, and/or portions, these members, areas, layers and/or portions are not limited by these terms. These terms do not mean particular order, top and bottom, or ratings but are used only to distinguish one member, area, or portion from another member, area, or portion. Accordingly, a first member, area, or portion which will be described below may be referred to as a second member, area, or portion without departing from the scope of the present invention.

[0028] Hereinafter, exemplary embodiments of the present invention will be described in detail with reference to the attached drawings.

[0029] FIG. 3 is a block diagram of an ultrasonic diagnostic system applicable to a wireless communication terminal with various resolution levels according to an embodiment of the present invention.

[0030] As shown in the drawings, the ultrasonic diagnostic system applicable to a wireless communication terminal with various resolution levels according to the embodiment of the present invention includes an ultrasonic diagnostic apparatus 100 and a wireless communication terminal 200 which transmit and receive ultrasonic image signals through wireless communication.

[0031] The ultrasonic diagnostic apparatus 100 may form scan data using frame data obtained from an ultrasonic probe 110 to correspond to a resolution level of a display screen of the wireless communication terminal 200 and to have an optimal bandwidth adequate for data transmission.

[0032] Also, the wireless communication terminal 200 may receive the scan data from the ultrasonic diagnostic apparatus 100 and may scan-convert the scan data into an ultrasonic image adequate for a resolution level of its own display.

[0033] In more detail, the ultrasonic diagnostic apparatus 100 may include the ultrasonic probe 110, a beam former 120, a resolution information reception portion 130, a scan data resolution database (DB) 140, a scan data generation portion 150, and a scan data transmission portion 160.

[0034] The ultrasonic probe 110 may transmit an ultrasonic signal to an object and may receive an echo signal reflected from the object.

[0035] Also, the beam former 120 may collect the echo signal reflected from the ultrasonic probe 110 and may generate frame data.

5 [0036] The resolution information reception portion 130 may receive resolution information from the wireless communication terminal 200.

[0037] Following Table 1 shows a type of a wireless communication terminal with various resolution levels.

[Table 1]

Operating system	Resolution	Product names
	320×480	iPhone 3
	640×960	iPhone 4
IOS	640×1136	iPhone 5
	768×1024	iPad 1, iPad 2, iPad mini
	1536×2048	iPad 3, iPad 4
Android	480×800	Galaxy S, Galaxy S2, Nexus S, HTC desired Hd
	800×1280	Galaxy Tab 10.1, Galaxy Note 1, Nexus 7
	720×1280	Galaxy S3, Galaxy S2 HD, Galaxy Note 2, Optimus G
	1200×1920	Nexus 7 (2013)
	1080×1920	G2, Galaxy S4, Galaxy Note 3

[0038] As shown in Table 1, a wireless communication terminal applicable to the embodiment of the present invention may have various resolution levels.

30 [0039] Accordingly, when the ultrasonic diagnostic apparatus 100 transmits an ultrasonic image to the wireless communication terminal 200, to prevent a distortion of an ultrasonic image signal, it is necessary to transmit an ultrasonic image with a resolution level higher than the resolution information received at the resolution information reception portion 130.

[0040] Meanwhile, scan data capable of corresponding to the resolution information of the wireless communication terminal with various resolution levels and increasing efficiency of a bandwidth while wireless communication is performed may be set and mapped in advance and stored in the scan data resolution DB 140.

[0041] Following Table 2 shows a bandwidth (Mbits/sec) used according to a volume of scan data transmitted through wireless communication.

[Table 2]

Volume of scan data	Bandwidth (Mbits/sec)
4K BYTE	120
2K BYTE	60
1KBYTE	30

[0042] As shown in Table 2, an occupied transmission bandwidth may vary according to the volume of the scan data.

50 [0043] Here, it is indicated that when the volume of the scan data is 4K bytes, pixel information of an ultrasonic image transmitted from an ultrasonic diagnostic apparatus to a wireless communication terminal through wireless communication is about 4,000 pieces.

[0044] For example, it may be known that since iPhone 4 with resolution of 640×960 in Table 1 has just scan data of 1K bytes, when the scan data of 4K bytes is transmitted, pixel information of about 3000 pieces is not used and abandoned. Here, referring to Table 2 for a transmission bandwidth, transmission bandwidths are occupied more than necessary, thereby reducing efficiency.

55 [0045] Accordingly, like the embodiment of the present invention, when the scan data resolution DB 140 in which scan data is set and mapped in advance is used, it is possible to efficiently utilize the transmission bandwidth.

[0046] Following Table 3 shows a scan and mapped embodiment in the scan data resolution DB 140.

[Table 3]

Volume of scan data	Supported Resolution		
4K BYTE	1200×1920	1080×1920	1536×2048
2K BYTE	800×1280	720×1280	768×1024
1KBYTE	480×800	640×960	640×1136

[0047] The scan data generation portion 150 may compare mapping information of the scan data resolution DB 140 and generate scan data to be transmitted to the wireless communication terminal from the frame data using the resolution information received at the resolution information reception portion 130 from the wireless communication terminal 200 according to the embodiment of Table 3.

[0048] That is, as described above, in the case of iPhone 4 with resolution of 640×960, the scan data generation portion 150 may generate scan data of 1K which supports it.

[0049] FIG. 4 is a flowchart illustrating a process of generating a transmission packet by sampling according to a transmission volume as an embodiment.

[0050] As shown in the drawings, according to the embodiment of the present invention, a transmission packet may be generated and transmitted while the volume of total data is adjusted according to the volume of scan data.

[0051] As described above, the ultrasonic diagnostic apparatus 100 may transmit scan data generated by the scan data generation portion 150 using the scan data transmission portion 160 shown in FIG. 3.

[0052] Also, the wireless communication terminal 200 of the ultrasonic diagnostic system applicable to a wireless communication terminal with various resolution levels according to the embodiment of the present invention includes a display portion 210, a resolution information generation portion 220, a data transmission/reception portion 230, a scan-conversion resolution database 240, an application control portion 250, and a scan-conversion portion 260.

[0053] In more detail, the display portion 210 may include a display screen with various resolution levels as described above to display an ultrasonic image according to a type of a wireless communication terminal and may be provided at one of wireless communication terminals such as a personal computer (PC), a smart phone, a tablet type device, a pad type device, personal digital assistants (PDA), etc. connected through wireless communication.

[0054] The resolution information generation portion 220 may generate resolution information corresponding to the display screen of the display portion 210.

[0055] In the embodiment of the present invention, physical resolution information of the display screen may be obtained using a device driver of the display portion 210.

[0056] Here, including the resolution information generation portion 220, the scan-conversion resolution DB 240 and the application control portion 250 which will be described below may be embodied as independent application programs installed in a wireless communication terminal.

[0057] Also, the data transmission/reception portion 230 may perform wireless communication with the ultrasonic diagnostic apparatus 100 and transmit and receive the resolution information generated by the resolution information generation portion 220 of the wireless communication terminal and the scan data of the ultrasonic diagnostic apparatus 100.

[0058] FIG. 5 is a view illustrating a packet structure when a data transmission/reception portion 230 transmits resolution information.

[0059] A packet header may indicate a packet for data communication and may store a total volume of the packet. A command may indicate an operation command to be performed using the packet or a response for the command. A body may store data corresponding to the command or the response.

[0060] Meanwhile, the scan-conversion resolution DB 240 shown in FIG. 3 may store a size of an ultrasonic image capable of being scan-converted corresponding to the resolution information generated by the resolution information generation portion 220 of FIG. 3 which is set and mapped in advance.

[0061] Following Table 4 shows a set and mapped embodiment in the scan-conversion resolution DB 240.

[Table 4]

Volume of scan data	Supported Resolution of Wireless communication terminal		
1080×1080	1200×1920	1080×1920	1536×2048
720×720	800×1280	720×1280	768×1024
640×640	480×800	640×960	640×1136

[0062] As shown in Table 4, it may be known that sizes of ultrasonic images vary according to supported resolution levels of wireless communication terminals.

[0063] Accordingly, the application control portion 250 of the wireless communication terminal 200 may map an ultrasonic image corresponding to resolution information of the display screen of the display portion 210 using the scan-conversion resolution DB 240.

[0064] Next, the scan-conversion portion 260 may form an ultrasonic image adequate for resolution supported by the display screen by performing scan conversion on the scan data received from the ultrasonic diagnostic apparatus 100 using mapping information obtained from the application control portion 250.

[0065] As described above, the ultrasonic diagnostic system applicable to a wireless communication terminal with various resolution levels according to the embodiment of the present invention may increase efficiency of a transmission/reception bandwidth because the ultrasonic diagnostic apparatus 100 forms and transmits frame data obtained from the ultrasonic probe 110 as scan data corresponding to the resolution of the wireless communication terminal 200 and may be applied to the wireless communication terminal 200 with various resolution levels because the wireless communication terminal 200 may scan-convert the scan data received from the ultrasonic diagnostic apparatus 100 into an ultrasonic image adequate for the display screen with various resolution levels.

[0066] FIG. 6 is a flowchart of an ultrasonic diagnostic method applicable to a wireless communication terminal with various resolution levels according to an embodiment of the present invention.

[0067] Referring to FIG. 6, a diagnostic method of the ultrasonic diagnostic system described with reference to FIG. 3 will be described as follows.

[0068] As shown in the drawing, the diagnostic method of the ultrasonic diagnostic system applicable to a wireless communication terminal with various levels according to the embodiment of the present invention includes generating frame data (S10), generating resolution information (S20), transmitting the resolution information (S30), generating scan data (S40), transmitting the scan data (S50), scan-converting the scan data into an ultrasonic image (S60), and displaying the ultrasonic image on a display screen (S70).

[0069] In more detail, the generating of the frame data (S10) is a first operation in which the beam former 120 which forms the ultrasonic diagnostic apparatus 100 of FIG. 3 generates the frame data using an echo signal collected by the ultrasonic probe 110.

[0070] Next, the generating of the resolution information (S20) may be an operation of performing one function of an application program independently executed by the wireless communication terminal 200 of FIG. 3.

[0071] That is, the generating of the resolution information (S20) is a second operation in which the resolution information generation portion 220 of FIG. 3 requests display information from an exclusive operating system of the wireless communication terminal 200, a resolution level of the display screen is obtained through a device driver of the operating system, and then the resolution information is generated by providing the resolution level to the application program again.

[0072] Next, the transmitting of the resolution information (S30) is a third operation in which the resolution information obtained in the second operation using the data transmission/reception portion 230 of FIG. 3 which forms the wireless communication terminal 200 and the resolution information reception portion 130 of FIG. 3 which forms the ultrasonic diagnostic apparatus 100 is transmitted from the wireless communication terminal 200 to the ultrasonic diagnostic apparatus 100.

[0073] Also, the generating of the scan data (S40) is a fourth operation in which the resolution information of the wireless communication terminal 200 obtained in the second operation is compared with mapping information of the scan data resolution DB 140 of FIG. 3 and the frame data generated by the beam former 120 of FIG. 3 is generated as scan data to be transmitted to the wireless communication terminal according to the mapping information.

[0074] After that, the transmitting of the scan data (S50) is a fifth operation in which the scan data is transmitted from the ultrasonic diagnostic apparatus 100 to the wireless communication terminal 200 through the scan data transmission portion 160 of the ultrasonic diagnostic apparatus 100 of FIG. 3 and the data transmission/reception portion 230 of the wireless communication terminal 200.

[0075] Meanwhile, in the embodiment of the present invention, as a wireless communication method performed between the ultrasonic diagnostic apparatus 100 and the wireless communication terminal 200 in the third operation (S30) and the fifth operation (S50), one of Bluetooth, a wireless universal serial bus (USB), a wireless local area network (LAN), wireless fidelity (WiFi), Zigbee, and an infrared data association (IrDA).

[0076] Also, the scan-converting of the scan data into the ultrasonic image (S60) is a sixth operation in which the ultrasonic image corresponding to the resolution information is mapped by the application control portion 250 which forms the wireless communication terminal 200 referring to the scan-conversion resolution DB 240 and then the scan data received from the ultrasonic diagnostic apparatus 100 is scan-converted into an ultrasonic image adequate for resolution information of the display screen by the scan-conversion portion 260.

[0077] Next, the ultrasonic image on which scan-conversion is completed may be displayed by the display portion 210.

[0078] Hereinafter, an example of an ultrasonic diagnostic apparatus according to one embodiment of the present invention will be described.

[0079] The ultrasonic diagnostic apparatus according to one embodiment of the present invention performs receiving resolution information of a terminal wirelessly connected and operating while interconnected with the ultrasonic diagnostic apparatus from the terminal, determining scan data generated using the resolution information received from the terminal into a volume adequate for the resolution information using a setting table and a method of sampling or interpolation, and generating transmission data or a packet with respect to the ultrasonic image according to the determination and transmitting it to the terminal.

[0080] Hereinafter, an example of a terminal interconnected with the ultrasonic diagnostic apparatus according to one embodiment of the present invention will be described.

[0081] There are operations of requesting resolution information with respect to the terminal from the ultrasonic diagnostic apparatus; transmitting the resolution information of the terminal to the ultrasonic diagnostic apparatus according to the request; receiving ultrasonic image data from the ultrasonic diagnostic apparatus; and generating an ultrasonic image from the received ultrasonic image data using an image processor.

[0082] As described above, according to the embodiments of the present invention, since frame data formed by a beam former of an ultrasonic diagnostic apparatus is formed as scan data corresponding to a resolution level of a wireless communication terminal and then transmitted to the wireless communication terminal, a transmission/reception bandwidth may be efficiently utilized.

[0083] Also, since the scan data transmitted from the ultrasonic diagnostic apparatus may be independently scan-converted into an adequate resolution level at the wireless communication terminal, there are provided an ultrasonic diagnostic system and method applicable to wireless communication terminals with various resolution levels.

[0084] While the present invention has been described in detail, it should be known that the embodiments described above are only exemplary and not limitative and it will be understood that various changes in form and details may be made therein without departing from the spirit and scope of the present invention as defined by the following claims.

Claims

1. An ultrasonic diagnostic system formed of an ultrasonic diagnostic apparatus and a wireless communication terminal and applicable to a wireless communication terminal with various resolution levels, comprising:

the ultrasonic diagnostic apparatus which converts frame data obtained by collecting an echo signal at an ultrasonic probe into scan data corresponding to a resolution level of a display screen of the wireless communication terminal; and
the wireless communication terminal which receives the scan data from the ultrasonic diagnostic apparatus and scan-converts the scan data into an ultrasonic image adequate for the resolution level of the display screen thereof.

2. The ultrasonic diagnostic system of claim 1, wherein the ultrasonic diagnostic apparatus comprises:

an ultrasonic probe which transmits an ultrasonic signal to an object and receives an echo signal reflected by the object;
a beam former which generates frame data by collecting the echo signal reflected from the ultrasonic probe;
a resolution information reception portion which receives resolution information from the wireless communication terminal;
a scan data resolution database (DB) in which scan data capable of corresponding to the resolution information of the wireless communication terminal with various resolution levels and increasing efficiency of a bandwidth while performing wireless communication;
a scan data generation portion which compares the resolution information received by the resolution information reception portion with mapping information of the scan data resolution DB and generates scan data to be transmitted to the wireless communication terminal using the frame data; and
a scan data transmission portion which transmits the scan data generated by the scan data generation portion to the wireless communication terminal.

3. The ultrasonic diagnostic system according to any one of claims 1 and 2, wherein the wireless communication terminal comprises:

a display portion which displays an ultrasonic image;
a resolution information generation portion which generates resolution information corresponding to a display screen of the display portion;

a data transmission/reception portion which transmits and receives the resolution information and scan data by performing wireless communication with the ultrasonic diagnostic apparatus;
 a scan-conversion resolution DB in which a size of an ultrasonic image capable of being scan-converted corresponding to the resolution information, which is set and mapped in advance, is stored;
 5 an application control portion which maps an ultrasonic image corresponding to the resolution information of the display screen using the scan-conversion resolution DB; and
 a scan-conversion portion which scan-converts the scan data received from the ultrasonic diagnostic apparatus into an ultrasonic image adequate for a resolution level of the display screen.

10 **4.** A diagnostic method of an ultrasonic diagnostic system applicable to a wireless communication terminal and comprising an ultrasonic diagnostic apparatus which forms scan data corresponding to a resolution level of a display screen of the wireless communication terminal using frame data obtained by collecting an echo signal from an ultrasonic probe and the wireless communication terminal which receives the scan data from the ultrasonic diagnostic apparatus and scan-convert the scan data into an ultrasonic image adequate for the resolution level of the display screen, the method comprising:

a first operation of generating the frame data, by a beam former, by collecting the echo signal of the ultrasonic probe;
 a second operation of generating resolution information of the display screen, by a resolution generation portion of the wireless communication terminal, using a device driver;
 20 a third operation of transmitting the resolution information from the wireless communication terminal to the ultrasonic diagnostic apparatus through a data transmission/reception portion of the wireless communication terminal and a resolution information reception portion of the ultrasonic diagnostic apparatus;
 a fourth operation of comparing the resolution information of the wireless communication terminal with mapping information of a scan data resolution DB and then generating scan data to be transmitted to the wireless communication terminal using the frame data generated by the beam former according to the mapping information;
 25 a fifth operation of transmitting the scan data from the ultrasonic diagnostic apparatus to the wireless communication terminal through a scan data transmission portion of the ultrasonic diagnostic apparatus and the data transmission/reception of the wireless communication terminal;
 30 a sixth operation of mapping an ultrasonic image corresponding to the resolution information, by an application control portion, by referring to a scan-conversion resolution DB and then scan-converting the scan data received from the ultrasonic diagnostic apparatus, by a scan-conversion portion, into an ultrasonic image adequate for the resolution information of the display screen; and
 35 a seventh operation of displaying the ultrasonic image on which scan conversion is completed by a display portion.

40

45

50

55

FIG. 1
(PRIOR ART)

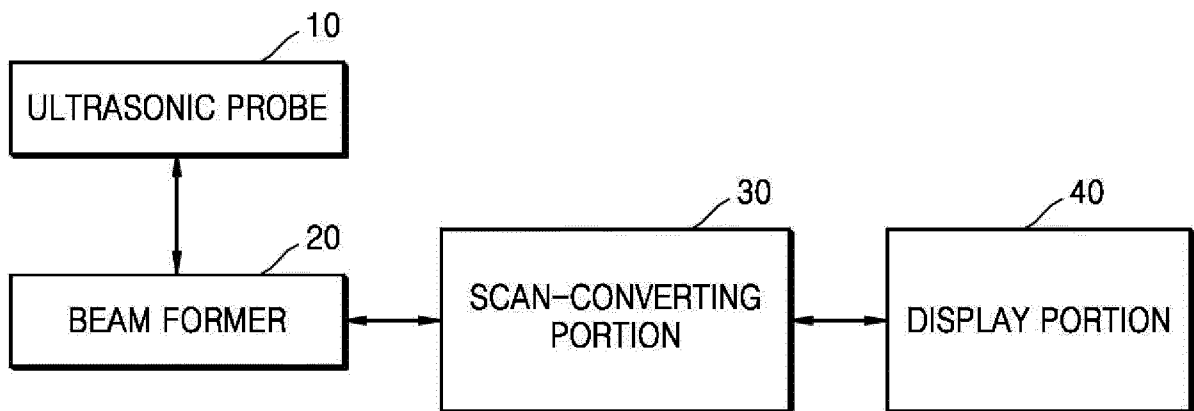

FIG. 2
(PRIOR ART)

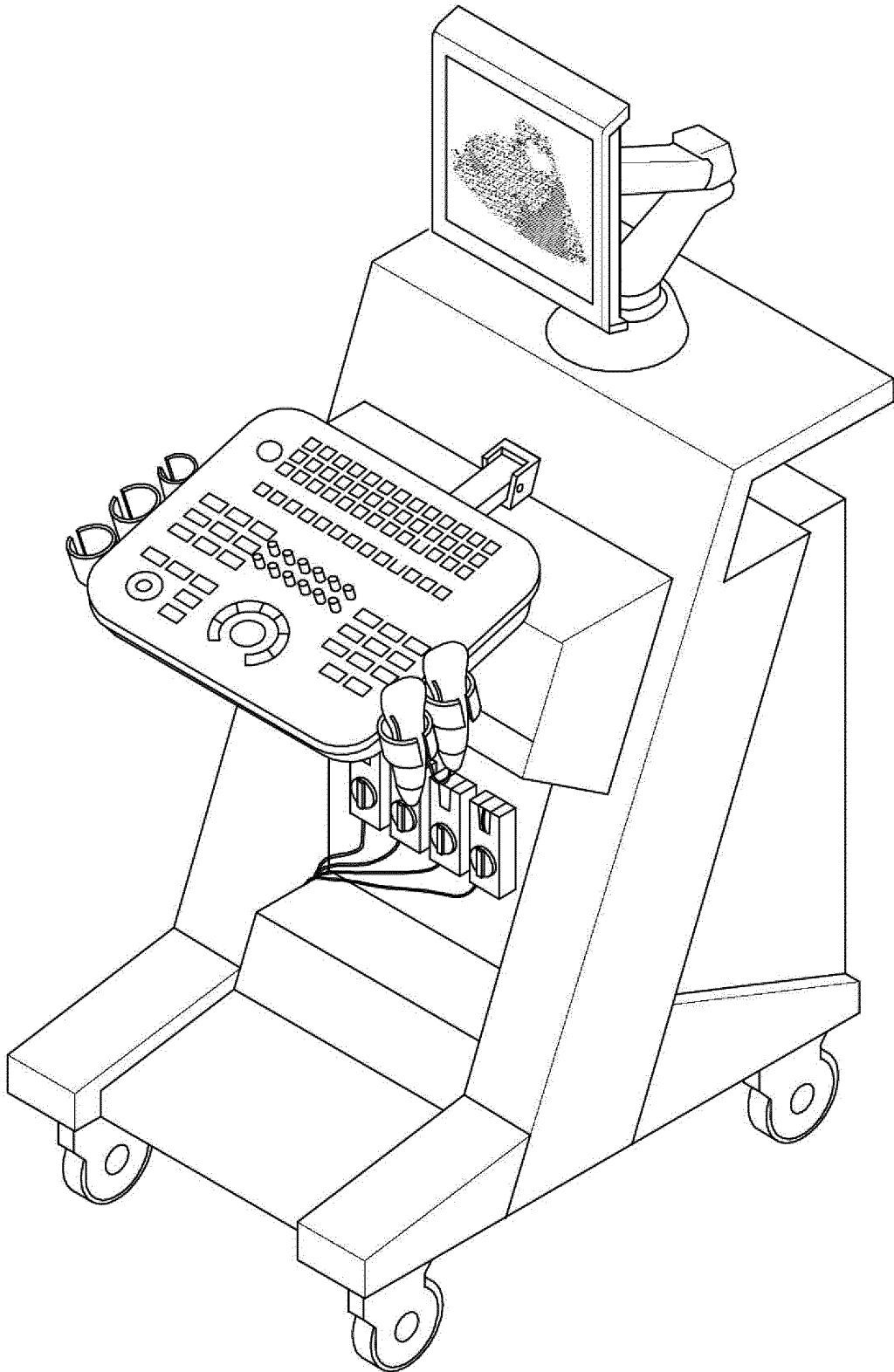

FIG. 3

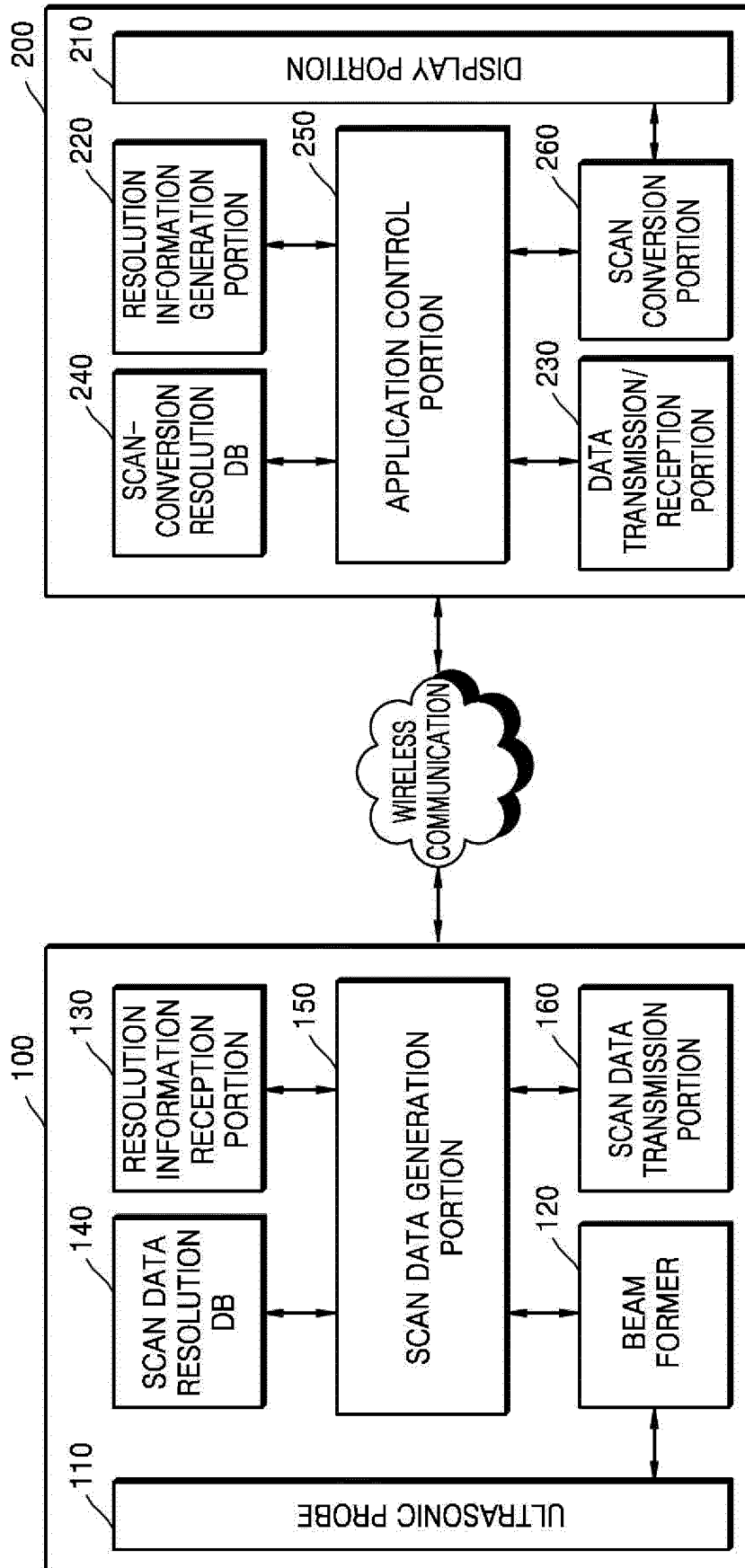

FIG. 4

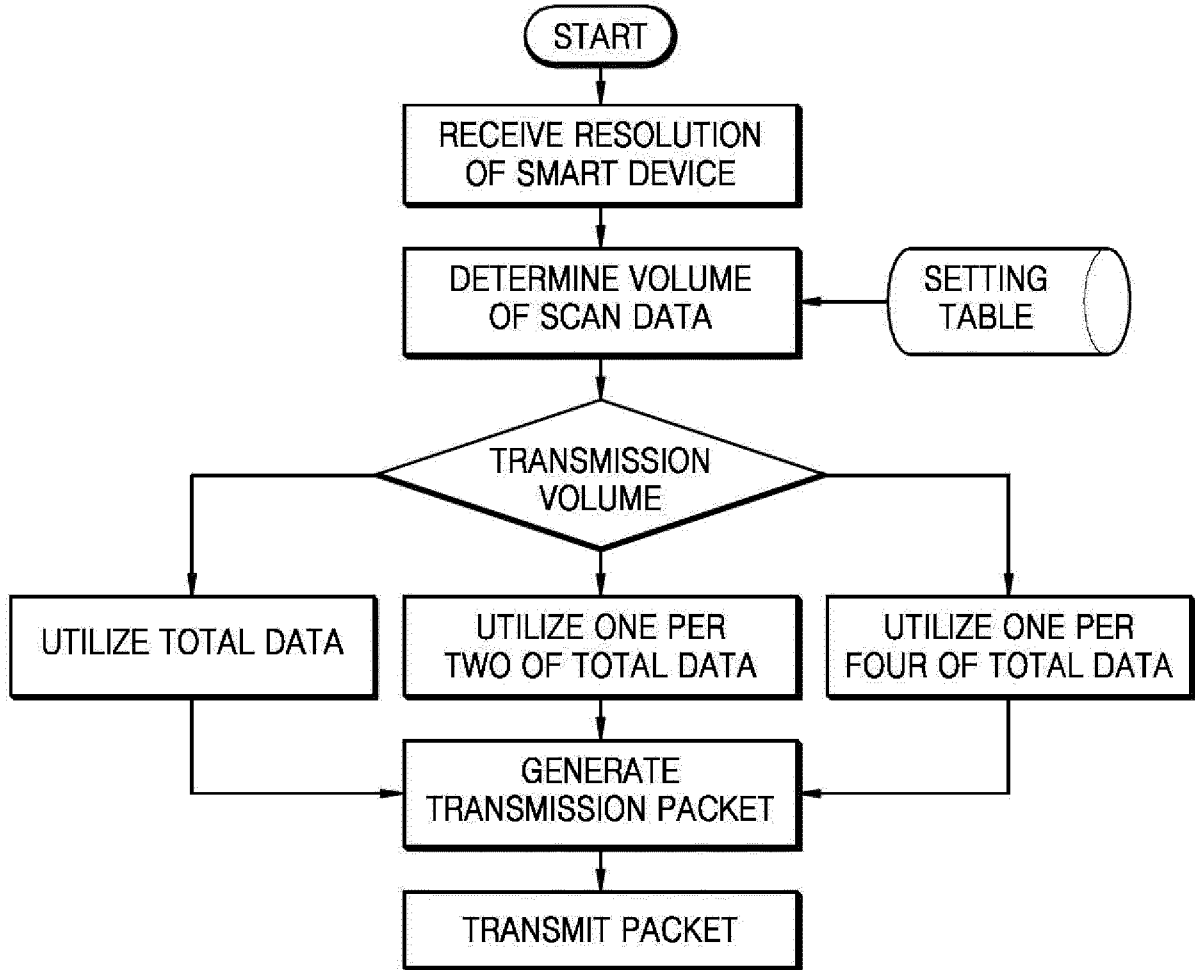

FIG. 5

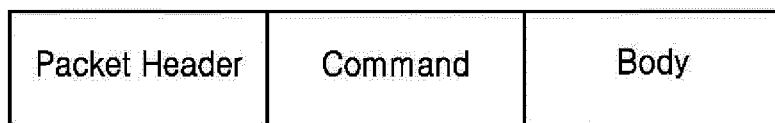
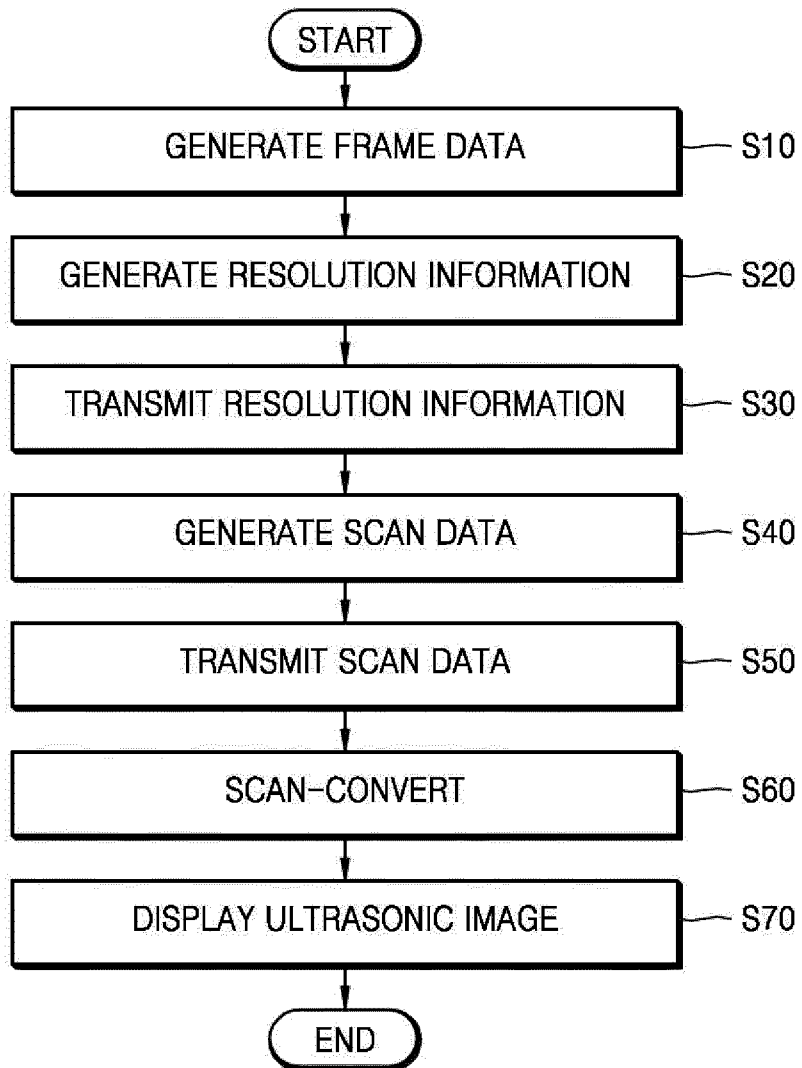

FIG. 6



INTERNATIONAL SEARCH REPORT

International application No.
PCT/KR2015/002433

5

A. CLASSIFICATION OF SUBJECT MATTER
A61B 8/00(2006.01)i, G01N 29/24(2006.01)i
According to International Patent Classification (IPC) or to both national classification and IPC

10

B. FIELDS SEARCHED
Minimum documentation searched (classification system followed by classification symbols)
A61B 8/00

15

Documentation searched other than minimum documentation to the extent that such documents are included in the fields searched
Korean Utility models and applications for Utility models: IPC as above
Japanese Utility models and applications for Utility models: IPC as above
Electronic data base consulted during the international search (name of data base and, where practicable, search terms used)
cKOMPASS (KIPO internal) & Keywords: ultrasonic diagnostic equipment, wireless communication terminal, resolution, mapping, scan conversion

20

C. DOCUMENTS CONSIDERED TO BE RELEVANT

25

30

35

40

Category*	Citation of document, with indication, where appropriate, of the relevant passages	Relevant to claim No.
Y	JP 2013-158479 A (HITACHI ALOKA MEDICAL LTD.) 19 August 2013 See abstract, paragraphs [0002]-[0006], [0012]-[0014], claim 1.	1-4
Y	JP 2013-000312 A (KONICA MINOLTA MEDICAL & GRAPHIC INC.) 07 January 2013 See abstract, paragraphs [0078]-[0086], figure 9.	1-4
A	KR 10-2014-0026289 A (SAMSUNG MEDISON CO., LTD. et al.) 05 March 2014 See abstract, paragraphs [0064]-[0069], claim 5, figure 9.	1-4
A	KR 10-2012-0029679 A (ELECTRONICS AND TELECOMMUNICATIONS RESEARCH INSTITUTE) 27 March 2012 See abstract, claims 1-2, figure 1.	1-4

45

50

55

Further documents are listed in the continuation of Box C. See patent family annex.

* Special categories of cited documents:
 "A" document defining the general state of the art which is not considered to be of particular relevance
 "E" earlier application or patent but published on or after the international filing date
 "L" document which may throw doubts on priority claim(s) or which is cited to establish the publication date of another citation or other special reason (as specified)
 "O" document referring to an oral disclosure, use, exhibition or other means
 "P" document published prior to the international filing date but later than the priority date claimed
 "I" later document published after the international filing date or priority date and not in conflict with the application but cited to understand the principle or theory underlying the invention
 "X" document of particular relevance; the claimed invention cannot be considered novel or cannot be considered to involve an inventive step when the document is taken alone
 "Y" document of particular relevance; the claimed invention cannot be considered to involve an inventive step when the document is combined with one or more other such documents, such combination being obvious to a person skilled in the art
 "&" document member of the same patent family

Date of the actual completion of the international search 24 APRIL 2015 (24.04.2015)	Date of mailing of the international search report 30 APRIL 2015 (30.04.2015)
Name and mailing address of the ISA/KR  Korean Intellectual Property Office Government Complex-Daejeon, 189 Seonsa-ro, Daejeon 302-701, Republic of Korea Facsimile No. 82-42-472-7140	Authorized officer Telephone No.

INTERNATIONAL SEARCH REPORT
Information on patent family members

International application No.

PCT/KR2015/002433

5

10

15

20

25

30

35

40

45

50

55

Patent document cited in search report	Publication date	Patent family member	Publication date
JP 2013-158479 A	19/08/2013	CN 104114094 A JP 5390645 B2 US 2015-0080728 A1 WO 2013-118359 A1	22/10/2014 15/01/2014 19/03/2015 15/08/2013
JP 2013-000312 A	07/01/2013	NONE	
KR 10-2014-0026289 A	05/03/2014	WO 2014-030933 A1	27/02/2014
KR 10-2012-0029679 A	27/03/2012	US 2012-0071756 A1	22/03/2012

专利名称(译)	适用于具有各种分辨率等级的无线通信终端的超声波诊断系统和诊断方法		
公开(公告)号	EP3138500A4	公开(公告)日	2017-05-03
申请号	EP2015786419	申请日	2015-03-13
[标]申请(专利权)人(译)	和赛仑有限公司		
申请(专利权)人(译)	healcerion有限公司		
当前申请(专利权)人(译)	healcerion有限公司		
[标]发明人	RYU JEONG WON CHOUNG YOU CHAN CHUNG WOOK JIN		
发明人	RYU, JEONG WON CHOUNG, YOU CHAN CHUNG, WOOK JIN		
IPC分类号	A61B8/00 G01N29/24		
CPC分类号	A61B8/4411 A61B8/4427 A61B8/4433 A61B8/464 A61B8/54 A61B8/56 A61B8/00 G01N29/24 A61B8/14 A61B8/4472 A61B8/461 A61B8/5207 A61B8/565 G01N29/2481		
优先权	1020140050669 2014-04-28 KR		
其他公开文献	EP3138500A1 EP3138500B1		
外部链接	Espacenet		

摘要(译)

本发明涉及一种具有低功率模式的便携式超声波诊断装置及其执行方法，并且根据本发明的具有低功率模式的便携式超声波诊断装置包括：发射超声波的超声波探头向待检查对象发信号，然后接收从待检查对象反射的回波信号；波束形成器，用于收集从超声波探头反射的回波信号，以产生帧数据；扫描转换单元，扫描并转换在波束形成器中产生的帧数据，以形成超声图像；显示单元，具有显示屏，在该显示屏上显示扫描和转换的超声图像；如果在显示单元的超声图像中没有对图像进行超声波诊断，则用于在图像上存储图像数据的存储器；超声图像比较分析器，用于比较和分析显示单元的超声图像和存储在存储器中的图像数据；低功率模式控制单元，如果确定超声图像比较分析仪在显示单元上显示的超声图像是未进行超声诊断的超声图像，则使整个电路进入低功率模式出。