



(11) **EP 1 806 594 A3**

(12) **EUROPEAN PATENT APPLICATION**

(88) Date of publication A3:
12.12.2007 Bulletin 2007/50

(51) Int Cl.:
G01S 7/52 (2006.01) A61B 8/08 (2006.01)

(43) Date of publication A2:
11.07.2007 Bulletin 2007/28

(21) Application number: **07000170.6**

(22) Date of filing: **05.01.2007**

(84) Designated Contracting States:
AT BE BG CH CY CZ DE DK EE ES FI FR GB GR HU IE IS IT LI LT LU LV MC NL PL PT RO SE SI SK TR
Designated Extension States:
AL BA HR MK YU

(72) Inventors:

- **Kim, Hyoung Jin, Discusser & Medison Building Seoul 135-280 (KR)**
- **Hyun, Dong Gyu, Discusser & Medison Building Seoul 135-280 (KR)**
- **Ahn, Chi Young, Discusser & Medison Building Seoul 135-280 (KR)**

(30) Priority: **06.01.2006 KR 20060001591**

(74) Representative: **Schmid, Wolfgang Lorenz & Kollegen**
Alte Ulmer Strasse 2
89522 Heidenheim (DE)

(71) Applicant: **MEDISON CO., LTD.**
Kangwon-do 250-870 (KR)

(54) **Ultrasound system and method of displaying ultrasound image**

(57) An ultrasound system, which includes an ultrasound diagnostic unit for transmitting ultrasound signals to a target object in a periodic motion and forming ultrasound images based on receive signals reflected from the target object comprises a first storage unit for storing the ultrasound images provided from the ultrasound diagnostic unit together with the reception times of the receive signals; a cycle setting unit for setting a cycle of motion of the target object; a processor for selecting the

ultrasound images within a specific cycle among the ultrasound images stored in the first storage unit based on the reception times of the receive signals corresponding to the ultrasound images and start and end times of the specific cycle provided from the cycle setting unit, the processor further being configured to form an equal number of ultrasound images within each cycle based on the number of the selected ultrasound images; and a display unit for simultaneously displaying the ultrasound images within each cycle.

FIG. 1

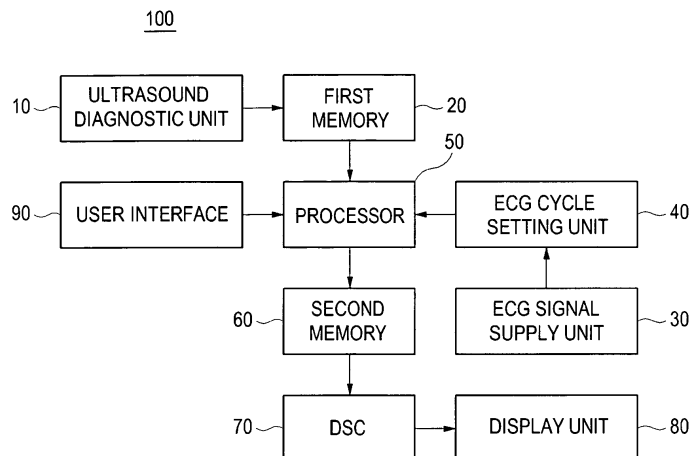

EP 1 806 594 A3



DOCUMENTS CONSIDERED TO BE RELEVANT			
Category	Citation of document with indication, where appropriate, of relevant passages	Relevant to claim	CLASSIFICATION OF THE APPLICATION (IPC)
X	US 2005/033123 A1 (GARDNER EDWARD A [US] ET AL) 10 February 2005 (2005-02-10) * page 1, paragraphs 13,14 * * page 2, paragraph 21-23 * * page 3, paragraph 25 - page 4, paragraph 41 * * figures 4,5 *	1-12	INV. G01S7/52 ADD. A61B8/08
X	US 2002/035329 A1 (KAMIYAMA NAOHISA [JP]) 21 March 2002 (2002-03-21) * page 2, paragraph 34-36 * * page 3, paragraphs 42,45 * * page 6, paragraphs 95,98 * * figures 10-12 *	1-12	
A	US 2004/066389 A1 (SKYBA DANNY M [US] ET AL) 8 April 2004 (2004-04-08) * page 2, paragraph 21-23 * * page 3, paragraph 25-34 * * figures 2,3 *	1-12	
A	US 2004/176689 A1 (YAMAUCHI MASAKI [JP]) 9 September 2004 (2004-09-09) * page 4, paragraphs 61,75,76 * * page 5, paragraphs 78,79,84,92 *	1,7,8,12	TECHNICAL FIELDS SEARCHED (IPC) A61B G01S
A	US 5 619 995 A (LOBODZINSKI SUAVE M [US]) 15 April 1997 (1997-04-15) * column 8, line 63 - column 9, line 2 * * column 9, line 27 - line 32 * * column 9, line 48 - column 10, line 12 * * column 13, line 24 - column 14, line 7 *	1,7,8,12	
The present search report has been drawn up for all claims			
Place of search The Hague		Date of completion of the search 30 October 2007	Examiner Dydenko, Igor
CATEGORY OF CITED DOCUMENTS X : particularly relevant if taken alone Y : particularly relevant if combined with another document of the same category A : technological background O : non-written disclosure P : intermediate document		T : theory or principle underlying the invention E : earlier patent document, but published on, or after the filing date D : document cited in the application L : document cited for other reasons & : member of the same patent family, corresponding document	

3
EPO FORM 1503 03.82 (P04/C01)

**ANNEX TO THE EUROPEAN SEARCH REPORT
ON EUROPEAN PATENT APPLICATION NO.**

EP 07 00 0170

This annex lists the patent family members relating to the patent documents cited in the above-mentioned European search report. The members are as contained in the European Patent Office EDP file on The European Patent Office is in no way liable for these particulars which are merely given for the purpose of information.

30-10-2007

Patent document cited in search report	Publication date	Patent family member(s)	Publication date
US 2005033123 A1	10-02-2005	NONE	
US 2002035329 A1	21-03-2002	JP 2002085409 A	26-03-2002
US 2004066389 A1	08-04-2004	NONE	
US 2004176689 A1	09-09-2004	US 2004215078 A1	28-10-2004
US 5619995 A	15-04-1997	NONE	

EPO FORM P0459

For more details about this annex : see Official Journal of the European Patent Office, No. 12/82

专利名称(译)	超声系统和显示超声图像的方法		
公开(公告)号	EP1806594A3	公开(公告)日	2007-12-12
申请号	EP2007000170	申请日	2007-01-05
申请(专利权)人(译)	MEDISON CO. , LTD.		
当前申请(专利权)人(译)	MEDISON CO. , LTD.		
发明人	KIM, HYOUNG JIN, DISCUSSE & MEDISON BUILDING HYUN, DONG GYU, DISCUSSE & MEDISON BUILDING AHN, CHI YOUNG, DISCUSSE & MEDISON BUILDING		
IPC分类号	G01S7/52 A61B8/08		
CPC分类号	A61B8/08 A61B8/463 A61B8/543 G01S7/52074 H01B17/02 H02G7/053		
代理机构(译)	SCHMID , WOLFGANG		
优先权	1020060001591 2006-01-06 KR		
其他公开文献	EP1806594A2		
外部链接	Espacenet		

摘要(译)

一种超声系统，包括：超声诊断单元，用于以周期性运动向目标对象发送超声信号；以及基于从目标对象反射的接收信号形成超声图像；包括第一存储单元，用于存储从超声诊断提供的超声图像单位与接收信号的接收时间一起；循环设定单元，用于设定目标物体的运动周期；处理器，用于基于与超声图像对应的接收信号的接收时间以及从周期设定单元提供的特定周期的开始和结束时间，选择存储在第一存储单元中的超声图像中的特定周期内的超声图像，处理器还被配置为基于所选择的超声图像的数量在每个周期内形成相同数量的超声图像；显示单元，用于在每个周期内同时显示超声图像。

FIG. 1

