



(51) International Patent Classification:
A61B 8/00 (2006.01)

(74) Agents: VINCENT, Lester, J. et al.; Blakely Sokoloff Taylor & Zafman LLP, 1279 Oakmead Parkway, Sunnyvale, CA 94085 (US).

(21) International Application Number:
PCT/US2013/073554

(81) Designated States (unless otherwise indicated, for every kind of national protection available): AE, AG, AL, AM, AO, AT, AU, AZ, BA, BB, BG, BH, BN, BR, BW, BY, BZ, CA, CH, CL, CN, CO, CR, CU, CZ, DE, DK, DM, DO, DZ, EC, EE, EG, ES, FI, GB, GD, GE, GH, GM, GT, HN, HR, HU, ID, IL, IN, IR, IS, JP, KE, KG, KN, KP, KR, KZ, LA, LC, LK, LR, LS, LT, LU, LY, MA, MD, ME, MG, MK, MN, MW, MX, MY, MZ, NA, NG, NI, NO, NZ, OM, PA, PE, PG, PH, PL, PT, QA, RO, RS, RU, RW, SA, SC, SD, SE, SG, SK, SL, SM, ST, SV, SY, TH, TJ, TM, TN, TR, TT, TZ, UA, UG, US, UZ, VC, VN, ZA, ZM, ZW.

(22) International Filing Date:
6 December 2013 (06.12.2013)

(25) Filing Language: English

(26) Publication Language: English

(30) Priority Data:
61/734,067 6 December 2012 (06.12.2012) US
61/734,291 6 December 2012 (06.12.2012) US

(71) Applicant: WHITE EAGLE SONIC TECHNOLOGIES, INC. [US/US]; 160 Saratoga Avenue, Suite 180, Santa Clara, CA 95051 (US).

(84) Designated States (unless otherwise indicated, for every kind of regional protection available): ARIPO (BW, GH, GM, KE, LR, LS, MW, MZ, NA, RW, SD, SL, SZ, TZ, UG, ZM, ZW), Eurasian (AM, AZ, BY, KG, KZ, RU, TJ, TM), European (AL, AT, BE, BG, CH, CY, CZ, DE, DK, EE, ES, FI, FR, GB, GR, HR, HU, IE, IS, IT, LT, LU, LV,

(72) Inventors: TOBIAS, Richard; 1123 Queensbridge Way, San Jose, CA 95120 (US). WU, Bicheng; 545 Channing Avenue, Palo Alto, CA 94301 (US). PARIKH, Ashish; 1465 Ben Roe Drive, Los Altos, CA 94024 (US).

[Continued on next page]

(54) Title: APPARATUS, SYSTEM, AND METHOD FOR ADAPTIVELY SCHEDULING ULTRASOUND SYSTEM ACTIONS

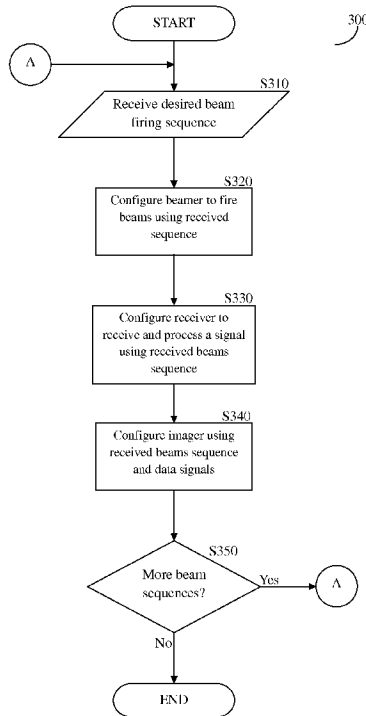

FIGURE 4

(57) Abstract: Apparatus for adaptively scheduling ultrasound device actions includes a probe interface, a beamer, a receiver, a processor, and a memory. The probe interface may interface with probe units to transmit signals generated by the beamer to the probe units and to receive data signals from the probe units. The processor may be coupled to the probe interface, the beamer, and the receiver. The memory may store instructions, which when executed by the processor, causes the processor to generate a task list that includes a timed beam firing sequence and to signal to the beamer to generate signals to the probe units associated with the plurality of task actions. The task list may include a plurality of task actions associated with probe units, and the processor may signal to the beamer in accordance with the timed beam firing sequence. Other embodiments are also described.

WO 2014/089426 A1

MC, MK, MT, NL, NO, PL, PT, RO, RS, SE, SI, SK, **Published:**
SM, TR), OAPI (BF, BJ, CF, CG, CI, CM, GA, GN, GQ, — *with international search report (Art. 21(3))*
GW, KM, ML, MR, NE, SN, TD, TG).

**APPARATUS, SYSTEM, AND METHOD FOR ADAPTIVELY SCHEDULING
ULTRASOUND SYSTEM ACTIONS**

CROSS-REFERENCED AND RELATED APPLICATIONS

[001] This application claims the benefit pursuant to 35 U.S.C. 119(e) of U.S. Provisional Application No. 61/734,291, filed December 6, 2012, which application is specifically incorporated herein, in its entirety, by reference.

[002] This application claims the benefit pursuant to 35 U.S.C. 119(e) of U.S. Provisional Application No. 61/734,067, filed on December 6, 2012, which application is specifically incorporated herein, in its entirety, by reference.

TECHNICAL FIELD

[003] Embodiments of the invention generally relate to the scheduling of actions for medical, industrial or other types of systems. More particularly, some embodiments relate to apparatuses, systems, and methods for adaptively scheduling actions in ultrasound systems, and more specifically, for scheduling ultrasound beam firing and data collection actions.

BACKGROUND

[004] Today's ultrasound systems have limited, fixed functionality and require sophisticated user control. Most ultrasound systems cannot provide multiple simultaneous functions. The ultrasound systems which can provide multiple simultaneous functions have the functions as fixed functions that are not flexible to user demands or need for adaptation. Accordingly, in these systems, a selection between different functions may be available, but no deviations that relate to timing of the fixed function are possible. For example, in the case of ultrasound systems, it may be possible to have a Doppler beam and a B-Mode beam. The combined functions of the different beams are provided as preprogrammed solutions. These solutions are selected, for example, by using a touch of a button. However, there is no flexibility provided to the user of the system for changes that require the reconfiguring and reshuffling of the timed scheduled actions that are included in the preprogrammed solutions.

[005] Moreover, some current imaging systems allow for combinations of, for example, a photoacoustic and ultrasound imager. These imaging systems use hardware counters to divide a clock to generate timing pulses for a transducer that supports both photoacoustic and ultrasound actions. However, these imaging systems provide little in the form of flexibility to adapt to needs of modern ultrasound imaging that may require changes that befit a specific imaging situation. Other

imaging systems provide ways for continuous interleaving of, for example, ultrasound beams. However, such interleaving is limited in its flexibility and being able to address the needs of future ultrasound imaging.

BRIEF DESCRIPTION OF THE DRAWINGS

[006] The embodiments of the invention are illustrated by way of example and not by way of limitation in the figures of the accompanying drawings in which like references indicate similar elements. It should be noted that references to “an” or “one” embodiment of the invention in this disclosure are not necessarily to the same embodiment, and they mean at least one. In the drawings:

[007] **Figure 1** shows an ultrasound system including an adaptive scheduler for adaptively scheduling ultrasound system actions according to an embodiment of the invention.

[008] **Figure 2** shows a flowchart of an example method for adaptively scheduling ultrasound system actions according to an embodiment of the invention.

[009] **Figure 3** shows a block diagram representation of the details of the processing unit of the ultrasound system according to an embodiment of the invention; and

[0010] **Figure 4** shows a flowchart of an example method for adaptively scheduling ultrasound system actions by the processing unit according to an embodiment of the invention.

DETAILED DESCRIPTION

[0011] In the following description, numerous specific details are set forth. However, it is understood that embodiments of the invention may be practiced without these specific details. In other instances, well-known circuits, structures, and techniques have not been shown to avoid obscuring the understanding of this description.

[0012] In the description, certain terminology is used to describe features of the invention. For example, in certain situations, the terms “component,” “unit,” “module,” and “logic” are representative of hardware and/or software configured to perform one or more functions. For instance, examples of “hardware” include, but are not limited or restricted to an integrated circuit such as a processor (e.g., a digital signal processor, microprocessor, application specific integrated circuit, a micro-controller, etc.). Of course, the hardware may be alternatively implemented as a finite state machine or even combinatorial logic. An example of “software” includes executable code in the form of an application, an applet, a routine or even a series of instructions. The software may be stored in any type of machine-readable medium.

[0013] In one embodiment, an adaptive hardware scheduler is configured to finely synchronize on a cycle basis the task actions performed by various hardware elements. In many cases, it is necessary to continuously adapt the schedule of operation or list of timing actions (“task list”) to be performed by the hardware elements. For instance, the order of the task actions that are to be performed by each of the hardware elements may need to be altered to adapt to a particular application or specific current need. Accordingly, the adaptive hardware scheduler is not merely a list of functions (“task actions”) executed from a table but rather it is an apparatus that adapts the scheduling of the task actions responsive of a user’s input and/or automatically responsive of information collected from external units, probe units, input devices etc. For example, the order of beam firing of an ultrasound system may be adaptively controlled.

[0014] A sophisticated ultrasound system supports multiple simultaneous functions such as imaging, blood flow measurement and heartbeat monitoring. The ultrasound system performs these functions by executing sequences of actions such as firing beams, receiving beam data, and moving mechanical arms. These actions frequently have rigorous real-time requirements. The ultrasound system performs functions by executing one or more parallel tasks, where each task requires a sequence of actions. The ultrasound system cannot perform conflicting actions at the same time. Accordingly, in some embodiments, actions conflict if they require the same resource, e.g., the same transmitter, the same receiver or the same area of memory. In other embodiments, actions conflict if the ultrasound beams from two different transmitters travel through the same area of the target and make it impossible for a receiver to identify the source.

[0015] Further, some actions depend on events that cannot be accurately predicted. For example, the system may need to wait for a mechanical arm to complete its movement before it fires the next beam. The system must wait for a laser (i.e., L.A.S.E.R.) to be charged before it can fire a laser beam. The time taken to charge a laser varies significantly and cannot be predicted to the required accuracy. The ultrasound system indicates the completion of mechanical movement or laser charging by signaling events. Thus, some actions may depend on asynchronous events.

[0016] Accordingly, in some embodiments, the ultrasound system supports changes to the list of parallel tasks. For instance, a human user may view an ultrasound image and request new functions to be performed. An automated system may change the list of tasks in response to analysis of the ultrasound results. In some embodiments, the automated system uses the adaptive scheduler to schedule actions from the updated task list. Scheduling the actions may include signaling to a processor to send commands to other units to perform the actions. The adaptive scheduler may be implemented in hardware, software, firmware or any combination thereof as discussed below. In prior ultrasound systems, a skilled human operator is required to analyze results and modify ultrasound parameters. For example, an ultrasound operator may wish to locate a human heart valve, monitor the heart rate and measure the shape of the heart valve movement. In one embodiment of the invention, the automated system employs analysis software to monitor the ultrasound results. The analysis software determines the required task-list changes and signals an appropriate event to the adaptive scheduler. The analysis software modifies the task-list while searching for the heart valve. The analysis software starts new tasks when the ultrasound system locates the heart valve. Thus, the ultrasound system needs to respond to events that change the task list (e.g., when it receives an event indicating that the heart valve is located from the analysis software or from the end user). In this example, the event may be a signal received by the adaptive scheduler that indicates that the heart valve is located. The signal may be a single bit digital signal wherein the high signal ('1') may indicate that the heart valve is located.

[0017] Accordingly, in one embodiment of the invention, the adaptive scheduler further described below handles the scheduling of task actions. Each task to be performed may include a plurality of task actions. For instance, a task to be performed by the ultrasound system may be measuring the blood flow. The task actions included in the task of measuring the blood flow may include: firing one of the beams, and collecting the data (e.g., ultrasound data) from the beam. The adaptive scheduler adapts the schedule of task actions to ensure that actions do not conflict. When adapting the schedule of task actions, if actions are found to conflict, in one embodiment, the adaptive scheduler ensures that high priority actions are handled prior to lower priority actions. The adaptive scheduler handles events. The events may be signals received by the adaptive scheduler

that indicate the completion of certain tasks or task actions. For example, when an external unit (e.g, robot arm) has completed the movement required, the event received may be a signal that indicates that the external unit has completed the movement. The events may also be a signal received from an input device that indicates that a list of tasks has been inputted by the user. In some embodiments, events can cause the adaptive scheduler to pause task actions, modify task parameters, add or delete tasks and to invoke software procedures such as analysis software for locating a heart valve. In other embodiments, in response to events, the adaptive scheduler sends a signal to the processor to send commands to probe units or external units to start executing a task action. For instance, in response to receiving an event that indicates that data has been collected from a first beam associated with a higher priority, the adaptive scheduler may signal to the processor to send a start command to the second beam of a lower priority. In some embodiments, the adaptive scheduler sends the commands to the probe units or external units instead of the processor.

[0018] Figure 1 illustrates an ultrasound system including an adaptive scheduler for adaptively scheduling ultrasound system actions according to an embodiment of the invention. The ultrasound system 100 includes an adaptive scheduler 105 according to an embodiment. In one embodiment, the adaptive scheduler 105 is coupled to one or more probe units 110. Each probe unit 110 typically controls one or more transducers embodied therein. The transducers typically contain multiple elements capable of transmitting and receiving ultrasound beams. In one embodiment, the adaptive scheduler 105 is part of a processing unit 120 that handles user interactions, image display and system control. In one embodiment, the adaptive scheduler 105 is implemented as a software procedure executing on a processor. In some embodiments, the adaptive scheduler 105 includes a dedicated processor that is only used for adaptive scheduling. In a second embodiment the adaptive scheduler 105 is implemented in hardware. For instance, the adaptive scheduler 105 may include application-specific integrated circuit (ASIC) and/or field-programmable gate array (FPGA). The processing unit 120 may include a microprocessor, a microcontroller, a digital signal processor, or a central processing unit, and other needed integrated circuits such as glue logic. The term “processor” may refer to a device having two or more processing units or elements, e.g. a CPU with multiple processing cores. The processing unit 120 may be used to control the operations of the adaptive scheduler 105. For example, the processing unit 120 may executes software to control the adaptive scheduler 105 (e.g. to transmit and receive data to other components of system 100 (e.g., external units 150, probe unit 110)). In some cases, a particular function may be implemented as two or more pieces of software that are being executed by different hardware units of a processor.

[0019] In one embodiment, the processing unit 120 may send probe control commands, telling the probe units 110 when to fire specific beams and when to collect data. Such operation, as explained in further detail herein below, is performed, for example, from a memory 125 containing instructions that are executed by the processing unit 120. A memory 125 may also be included in the adaptive scheduler 120. The memory 125 that may include one or more different types of storage such as hard disk drive storage, nonvolatile memory, and volatile memory such as dynamic random access memory. The memory 125 may also include a database that stores data received from the probe units 110 and the external units 150. The memory 125 may also store instructions (e.g. software; firmware), which may be executed by the processing unit 120. As multiple operations of the ultrasound system may be needed (e.g., firing beams at various times), a task list is generated and altered by the adaptive scheduler 105 to address the combination of actions that are desired by the user of the system 100, further described herein. The processing unit 120 is configured to further retrieve data collected by a probe unit 110 data. The processing unit 120 may also take input commands from one or more input devices 130. The input devices 130 may be a keyboard, mouse, or touch screen that allows a user to input commands.

[0020] The input devices 130 typically provide high-level commands to the processing unit 120 which in turn, executes instructions stored in the embedded instruction memory 125 to perform methods of adaptively scheduling ultrasound system actions and specifically, to perform at least the tasks described in greater detail herein below. The processing unit 120 may output at least a result respective of the data collected to, for example, a display unit 140 that is coupled to the processing unit 120. A display unit 140 may be replaced or augmented by a storage unit (not shown) to allow the storing of the collected data for future use. The display unit 140 may show an image, a video comprised of a series of image frames and text, as well as combinations thereof.

[0021] While a single adaptive scheduler is referenced herein the use of a plurality of adaptive schedulers is possible without departing from the scope of the invention. As discussed above, the adaptive scheduler may be implemented in hardware, for example through a configurable circuit, or in memory of the system 100, where the memory is loaded with instructions, which when executed by the processor, causes the processor to perform methods of adaptively scheduling the task actions or cause the processor to control the adaptive scheduler, or adaptive schedulers. In one embodiment, cycle accurate timing for the firing of the beams is provided by the system 100 based, at least in part on the directions or signals received from the adaptive scheduler. In some embodiments, the adaptive scheduler may be used to configure at least a probe unit.

[0022] In one embodiment, the ultrasound system 100 may control one or more external units 150, such as, for example, lasers, robot arms and motors. The external units 150 may also

require time synchronization with probe units 110 operations. In one embodiment, the processing unit 120 sends external units 150 control commands based on the adaptive scheduler 105's selected task action as further explained below. For example, the processing unit 120 may send a control command telling a robot arm (e.g., external unit 150) to move a probe upon receipt of a signal from the adaptive scheduler 105 that has received an event indicating that a unit of data has been collected.

[0023] The ultrasound system 100 may receive a specification of ultrasound system tasks and events through, for example, input devices 130. The ultrasound system 100 generates a task identifying a sequence of task actions. Some of the task actions may have real-time constraints and some may depend on events. For instance, some task actions may not start until an event is received by the adaptive scheduler. For example, the task action may be to move a robot arm which cannot begin until an event is received that indicates that the data from a beam is finished being collected. In one embodiment, the ultrasound system 100 computes the time needed to complete each task action in the specification received. The ultrasound system 100 generates a list of the task actions using a linked list in memory 125. In some embodiments, the specification may include tasks and events that are associated with multiple beam firings of different types. A beam firing task action may require a setup time which is the amount of time needed to configure the transducer before firing a beam. The setup time may depend on the transducer. Different beam firing types are called modes. Switching modes (for example, switching from B-Mode mode to color-flow Doppler) typically requires a mode switching delay. The switching delay acts as an additional setup time. Each beam firing task action has a firing time, also known as pulse duration, which is the amount of time that the transducer outputs ultrasound waves. The firing time depends of the beam type and the purpose of the beam firing. For instance, a shorter firing time can give a better quality image. Doppler beams have a longer firing period than B-Mode beams. Each beam also has a collection time, which is the time needed to receive the reflected or pass-through ultrasound waves. The ultrasound propagation time depends on the medium through which the beam passes. The collection time depends on the depth of the scan. The ultrasound system 100 may need to distinguish the source of the collected data. Accordingly, the ultrasound system 100 may avoid two beams firing at the same time. A "dead-time" time interval between data collection and the next beam firing may also be introduced as needed.

[0024] Some beam types have a pulse repetition period which is the time between successive firings. Successive firings lead to the construction of a single image. Repeating this sequence of firings can generate multiple images. The ultrasound system 100 may, for instance,

have a requirement to generate 60 images per second. Doppler beams have a pulse repetition period whereas B-mode scan beams do not.

[0025] Some beam firings need to be consecutive in time. Using multi-focal-zones allows the ultrasound system 100 to get significantly better image quality. The ultrasound system 100 scans with beams focused at different distances. The ultrasound system 100 may scan with the first beam focused at 0-5 centimeters (cm), a second beam focused at 5-10 cm and a third beam focused at 10-15 cm. The data collected from the three different levels may be combined to form one line of an image. This beam firing sequence can be repeated using different collectors to generate a complete image. The ultrasound system 100 may need to schedule the actions that generate a single line consecutively.

[0026] In one embodiment, the processing unit 120 receives an input specification including a list of tasks (or task list) to be performed that includes ultrasound tasks and external unit tasks. Each ultrasound task may include, for example: the beam type, the number of beam firings, the setup time, the firing time, the dead-time, the pulse repetition period, the desired images per second rate, the number of multi-focal zones, and other timing constraints. Each external unit function (e.g., an external unit task) may include, for example: desired external unit task actions and the desired external unit task actions' timing constraints. The desired external unit task action may be for example a movement of a robot arm. The processing unit 120 or the adaptive scheduler 105 processes each task description and produces a list of sequential task actions such as beam firing actions and data collection actions. The task list may also include a plurality of tasks that are associated with a plurality of beams of differing priority levels. In some embodiments, the plurality of tasks includes at least one of a photoacoustic laser firing task and an electrocardiogram (ECG) task.

[0027] In one embodiment, the processing unit 120 creates a list of timing actions (“task list”) following the method described herein. It should be understood that the processing unit 120, in one embodiment, may schedule the dependent or independent operation of a plurality of probe units 110 connected to the probe interface 230 such that their beam firing is either dependent or independent of each other. Each of the probe units 110 may have, for example, its own task list of ultrasound actions that may be adaptively modified by the adaptive scheduler. In another embodiment, a single task list that may be adaptively modified by the adaptive scheduler may be used to cause the firing of beams by at least one of the plurality of probe units 110. Similarly, a plurality of external units 150 may be coupled to the probe interface 230 illustrated in **Figure 3**, or, in one embodiment, a dedicated interface (not shown) used to couple a plurality of external units 150 to the processing unit 120. In one embodiment, the adaptive scheduler 105 may use one or

more task lists to cause the operation of the one or more external devices 150. These operations being performed may be dependent or independent of each other. As discussed above, the ultrasound system 100 may receive a specification of ultrasound system tasks and events through, for example, a feedback resulting from measurements made by the system 100 or from input devices 130 (e.g., a change requested by a user of the system 100 by entering an input). These changes may occur in real-time as the system 100 executes the task list including the tasks that may include tasks and task actions that were earlier entered to the system 100. It should be further understood that task actions included in the task lists may be added as well as removed in real-time by the adaptive scheduler 105 and the task actions included in the task lists may also be added and removed when the system 100 is off-line for reconfiguration.

[0028] The following embodiments of the invention may be described as a process, which is usually depicted as a flowchart, a flow diagram, a structure diagram, or a block diagram. Although a flowchart may describe the operations as a sequential process, many of the operations can be performed in parallel or concurrently. In addition, the order of the operations may be re-arranged. A process is terminated when its operations are completed. A process may correspond to a method, a procedure, etc.

[0029] **Figure 2** shows a flowchart 200 of a method for adaptively scheduling ultrasound system actions according to an embodiment.

[0030] At S210 the adaptive scheduler checks if there are any events that require it to add new tasks to the task-list. As discussed above, the events may be signals that indicate end-user commands being received (e.g., a list of tasks being inputted by the user), commands or data from analysis software being received, hardware conditions being met (e.g., warming up of beams being completed), task and task actions being completed and other conditions being met. The adaptive scheduler checks for an event being received by reading from memory or register locations. Different events may have different memory and register locations. In one embodiment, the event may be a single bit digital signal that is stored in a given memory and register location. If event pertains to a robot arm, the single bit digital signal associated with a robot arm event being completed may be stored in the given memory and register location associated with that robot arm. If the adaptive scheduler finds an add-task event, it proceeds to S220 otherwise it proceeds to S230. At S220 the adaptive scheduler adds a new task to the task-list and then proceeds to S230. The task added depends on the type of event. For example, the task of measuring blood flow may be entered by user. This task may include the task actions of firing a beam and collecting the ultrasound data associated with the fired beam. Accordingly, in this example, the adaptive scheduler may add these task actions to the task list.

[0031] At S230 the adaptive scheduler checks if there are any events that require it to delete tasks from the task-list. If the adaptive scheduler finds a delete-task event, it proceeds to S240 otherwise it proceeds to S250. At S240 the adaptive scheduler deletes the task to the task-list and then proceeds to S250. In some embodiments, the S210, S220, S230, and S240 blocks in **Fig. 2** may be performed by the processor 210 without the adaptive scheduler 105's involvement.

[0032] As shown in **Fig. 2**, the method allows the adaptive scheduler to iterate over the task list. At S250, the adaptive scheduler selects the next task in the task list. On the first iteration, the adaptive scheduler selects the first task. The task list may be ordered in terms of priority with the highest priority being first. At S260, the adaptive scheduler determines if it could start the next task action of the selected task. As discussed above, each task includes at least one task action. In one embodiment, starting a task action includes transmitting commands to the probe unit and/or the external unit to perform or execute the task action. In another embodiment, starting a task action includes signaling to the processing unit 120 to transmit commands to the probe unit and/or the external unit to perform or execute the task action. In one embodiment, the adaptive scheduler cannot start the next task action if the ultrasound system is currently busy performing an action for the selected task. In another embodiment, the adaptive scheduler cannot start the next action if that action will interfere with an action of a higher priority task. More specifically, the adaptive scheduler may determine if the next task action of the selected task can complete before any conflicting, higher priority task's action needs to start. In one embodiment, the adaptive scheduler may analyze the timing parameters associated with the tasks to determine whether it may start the next task action. If the adaptive scheduler determines that it can start the selected task's next action, the method proceeds to S270, otherwise the method proceeds to S280. At S270, the adaptive scheduler starts the selected task's next action. After S270, the method then proceeds to S210.

[0033] At S280 the adaptive scheduler determines if it has completed iterating over the task list. If, at S280, the adaptive scheduler determines that it has not completed iterating over the task list, the method returns to S250 where the adaptive scheduler selects the next task to be processed. If the adaptive scheduler has completed iterating over the task list, the method proceeds to S210.

[0034] To further illustrate the operation of the method of **Fig. 2** the following example provides a non-limiting illustration of the operation according to flowchart 200. In this example, the ultrasound system is firing color flow Doppler beams which have a pulse repetition interval and rigorous real-time requirements. An end-user decides to start B-mode beams from a probe attached to a mechanical arm. The B-mode beams are targeted at the same area of the body as the color flow Doppler beams. B-mode beams do not have rigorous real-time requirements and have a lower priority than color flow Doppler beams. At S210, the adaptive scheduler tests for an add-task event

and finds there is an add-task event. At S220, the adaptive scheduler adds the B-mode beam task to the task list. At S250, the adaptive scheduler will select the higher priority color flow Doppler task from the task list. At S260, the adaptive scheduler determines that it can start the next color flow Doppler task action and at S270, it starts the next color flow Doppler task action. The method then proceeds to S210. In this example, no other task event is added or deleted in this iteration (at S210 and S230), and the adaptive scheduler selects the next color flow Doppler task action at S250. At S260, the adaptive scheduler determines that it cannot start the next color flow Doppler task action because the system is busy with the previous color flow Doppler task action (i.e., the color flow Doppler task action from the previous iteration). In this example, the adaptive scheduler then determines that it has not reached the end of the task list at S280 and the adaptive scheduler continues to iterate over the task-list. Specifically, the method returns to S250 for the adaptive scheduler to select the next task in the task list. In this example the next task in the task list is the B-mode task action. At S260, the adaptive scheduler determines if it can start a B-mode task action. In this example, the adaptive scheduler determines that it cannot start the B-mode task action because it would conflict with the higher priority color flow Doppler task action that is in progress. In this example, after the color flow task actions for the first beam firing and reception have completed, the adaptive scheduler can start a B-mode task action.

[0035] Further, in this example, after the initial B-mode beam firings, the image analysis software may determine that the system should move a mechanical arm. The image analysis software generates an event that causes the adaptive scheduler to determine at S210 to add a new task to the task-list at S220. For instance, the new task involves a mechanical arm movement such that the adaptive scheduler will make the B-mode task wait until it receives a mechanical arm movement complete event. After the adaptive scheduler has received the mechanical arm movement complete event, it determines if it can start the next B-mode task action at S260. The adaptive scheduler will not start the next B-mode task action if a color flow Doppler task action is taking place or if the B-mode task action cannot complete before the next color flow Doppler task action needs to take place.

[0036] **Figure 3** shows a block diagram representation of the details of the processing unit of the ultrasound system according to an embodiment of the invention. In this embodiment, the processing unit 120 comprises a high voltage generator 210, the memory 125 and the adaptive scheduler 105. The adaptive scheduler 105 may comprise a beamer 220, a probe interface 230, a receiver 204, an imager 250 and a processing element 260. In some embodiments, the adaptive scheduler 105 also includes the high voltage generator 210 and the memory 125. In the embodiment in **Figure 3**, the high voltage generator 210 is coupled to the beamer 220 and provides

the high voltage necessary for the proper operations of at least the probes 110. In one embodiment, the probes 110 may be coupled to the processing unit 120 through probe interface 230 which is coupled to the beamer 220. In one embodiment, the beamer 220 generates control signals that control different functions of the probes 110 (e.g., controls the firing of their beams). The beamer 220 may also generate the high voltage transmission signals that are converted by transducers included in the probe 110 into the ultrasound signals that are fired by the probes 110. The beamer 220 may provide the control signals and/or the high voltage transmission signals to the probes 110 via the probe interface 230. In one embodiment, the probe interface 230 is also used to interface to the external units 150. As shown in **Figure 3**, the probe interface 230 may further coupled to a receiver 240. The receiver 240 may receive and shape or process data signals from at least one of the probe units 110 into a useable form. For instance, the probe unit 110 generates ultrasound signals that are fired onto an object (e.g., human body) and the “bounce back” signal from the object is received by the probe unit 110 and transmitted to the receiver 240 via the probe interface 230. The receiver 240 may then shape and process the data signal from the probe unit 110 (e.g., the “bounce back” signal) and may provide the shaped data signals to an imager 250. In some embodiments, the receiver 240 may shape or process the signals by analog-to-digital conversion or by performing noise reduction or noise filtering. The receiver 240 may also receive and shape or process data signals from at least one of the external units 120. Thus, the imager 250 may be coupled to the receiver 240 and to a display 140. The imager 250 may generate display signals based on the data signals received from the receiver 240. The display signals may then be transmitted from the imager 250 to the display 140 to be displayed as an image, text and/or video. In other embodiments, the receiver 240 may further provide the data signals from the probe unit 110 to the processing element 260 to analyze the data signals and assess whether the next task action in the task list can start. For example, the probe unit 120 may transmit a data signal to the adaptive scheduler 105 via the probe interface 230, the data signal may be processed by the receiver 240 and provided to the processing element 260 that analyzes the shaped data signal and determines that the shaped data signal provides the results of a B-Mode beam firing which indicates that the task action of beam firing from the B-Mode beam is completed. Accordingly, in this example, the processing element 260 of the adaptive scheduler 105 determines that beam having a lower priority than the B-Mode beam may start its task action without interfering with the B-Mode beam’s task actions. As illustrated in **Figure 3**, the beamer 220, the receiver 240 and the imager 250 are coupled to the processing element 260 (e.g., processor, a digital signal processor, microprocessor, application specific integrated circuit, a micro-controller, etc.) that may further be coupled to a memory 125. The memory 125 contains instructions that when executed by the processor element 260 cause the

processing unit 120 (or the processor element 260) to control the adaptive scheduler 105 to adaptively schedule the tasks performed by the system 100 as described herein. For instance, the execution of the instructions stored in memory 125 may cause the processor element 260 to (i) signal to the beamer 220 to generate signals that cause the probes 110 to fire their beams and to provide the signals to the probes 110 via the probe interface 230, (ii) configure the receiver 240 to receive data signals from the probe 110 and/or the external units 120, and (iii) signal to the imager 250 to generate display signals based on the data signals received from the receiver 240. In another embodiment, as discussed above, the instructions stored in the memory 125 may be executed by a processor that is included in the processing unit 120 that is separate from the adaptive scheduler 105. The memory 125 may be further used to store data at least images generated by the imager 250. In one embodiment, the processing unit 120 may be implemented as a monolithic integrated circuit (IC) which may or may not include certain elements thereof. For example, high voltage generator 210 may be implemented off-chip. Furthermore, the system 120 may be implemented in whole or in part on a monolithic IC, including but not limited to a system-on-chip (SoC) implementation.

[0037] **Figure 4** shows a flowchart of an example method for adaptively scheduling ultrasound system actions by the processing unit according to an embodiment of the invention. The method 300 in **Figure 4** starts at S310 with the adaptive scheduler 105 receiving a desired sequence of beam firing, (e.g., the sequence of timed beam firings may be included in a task list). For example, the adaptive scheduler 105 may receive a sequence of beam firings required for an ultrasound imaging session that may include Doppler and B-mode beams. The adaptive scheduler 105 may check if there are any events that require it to add new tasks to the task list, may check if there are any events that require it to delete tasks from the task list, and while the adaptive scheduler 105 iterates over the task list, it determines if it could start the next task action of the selected task. For instance, the sequence of beam firing received may cause the adaptive scheduler 105 to add task actions (e.g., the plurality of beam firings identified in the sequence of beam firing) to the task list or delete task actions (e.g., lower priority task actions that conflict with the higher priority beam firings included in the beam firings identified in the sequence of beam firing) from the task list. While the adaptive scheduler 105 iterates over the task list, it determines if it could start each of the plurality of beam firings. In one embodiment, the adaptive scheduler 105 determines that it cannot start a first beam firing if the first beam firing conflicts with a second beam firing of higher priority.

[0038] In S320, a beamer, for example beamer 220, is configured using the received sequence of beam firing. In one embodiment, the beamer generates signals based on the received sequence of beam firing and provides the signals to the respective probes 110 via the probe

interface 230. This allows the system 100 to fire the beams as configured by the adaptive scheduler 105. In S330, a receiver, for example receiver 240, is configured using the received sequence of beam firing. This allows the system 100 to receive data signal that is associated with the beams that are identified in the sequence of beam firing. In one embodiment, the data signal is received from the probes used to fire the beams identified in the sequence of beam firing. The receiver 240 may also be configured using the received sequence of beam firing to shape the signals by analog-to-digital conversion or by performing noise reduction. In S340, if necessary, an imager, for example imager 250, is configured using the received sequence of beam firing and the received data signal from the receiver 240, to generate an image for display. In S350, the adaptive scheduler 105 may check whether there are additional beam sequences to be received and if so, the method 300 proceeds with execution at S310. If the adaptive scheduler 105 determines that no additional beam sequences are to be received, the method 300 terminates.

[0039] In one embodiment, the external devices 150 may also be similarly configured to enable the operation of the system 100. In this embodiment, the adaptive scheduler 105 may provide signals to the respective external devices 105 via the probe interface 230 in accordance with the task list received. The task list may include task actions to be performed by the external devices (e.g., moving a mechanical arm). In this embodiment, the receiver 240 may receive data signals that are associated with the external devices that are identified in the task list. These data signals may also be received from the external devices that are identified in the task list via the probe interface 230. It should be further understood that the system 100 may be dynamically configured. For example, by analyzing an image and/or a received signal, the adaptive scheduler 105 may generate a modified or otherwise new sequence of desired beam firing included in a task list. This modified or new sequence being generated may then automatically alter the operations of the system 100.

[0040] An embodiment of the invention may be a machine-readable medium having stored thereon instructions which program a processor to perform some or all of the operations described above. A machine-readable medium may include any mechanism for storing or transmitting information in a form readable by a machine (e.g., a computer), such as Compact Disc Read-Only Memory (CD-ROMs), Digital Versatile Disc (DVD), Flash Memory, Read-Only Memory (ROMs), Random Access Memory (RAM), and Erasable Programmable Read-Only Memory (EPROM). In other embodiments, some of these operations might be performed by specific hardware components that contain hardwired logic. Those operations might alternatively be performed by any combination of programmable computer components and fixed hardware circuit components.

[0041] While the invention has been described in terms of several embodiments, those of ordinary skill in the art will recognize that the invention is not limited to the embodiments described, but can be practiced with modification and alteration within the spirit and scope of the appended claims. The description is thus to be regarded as illustrative instead of limiting. There are numerous other variations to different aspects of the invention described above, which in the interest of conciseness have not been provided in detail. Accordingly, other embodiments are within the scope of the claims.

CLAIMS

1. A method of adaptively scheduling ultrasound device actions comprising:
 - selecting by an electronic circuit included in an adaptive scheduler a next task in a task list, wherein the task list includes a plurality of tasks scheduled to be performed by an ultrasound system, wherein each of the tasks includes a plurality of task actions;
 - determining by the electronic circuit if a task action included in the next task can start, wherein determining if the task action can start includes determining if the task action can be completed without interfering with a start of a higher priority task in the task list; and
 - signaling by the electronic circuit to a beam associated with the task action to start and perform the task action upon determination that the next task action can start.
2. The method of claim 1, further comprising:
 - determining by the electronic circuit whether the end of the task list has been reached upon determination that the next task action cannot start; and
 - selecting by the electronic circuit a task that follows the next task in the task list upon determination that the end of the task list has not been reached.
3. The method of claim 1, wherein the plurality of tasks includes a first beam task being a task associated with a first beam and a second beam task being a task associated with a second beam, the first beam having a higher priority level than the second beam.
4. The method of claim 1, wherein determining if the task action can start includes:
 - determining if the task action depends on receiving an event from at least one of a probe unit or an external device; and
 - determining if the event has been received upon determination that the task action depends on receiving the event.
5. An apparatus for adaptively scheduling ultrasound device actions comprising:
 - a probe interface to interface with at least one probe unit, the probe interface to transmit signals to the at least one probe unit and to receive data signals from the at least one probe units;
 - a beamer to generate the signals, wherein the beamer is coupled to the probe interface;
 - a receiver to receive and process the data signals from the probe interface;
 - a processor coupled to the probe interface, the beamer, and the receiver;
 - a memory to store instructions, which when executed by the processor, causes the processor
 - to generate a task list that includes a timed beam firing sequence, wherein the task list includes a plurality of task actions associated with the at least one probe unit, and

- to signal to the beamer to generate signals to the at least one probe unit associated with the plurality of task actions, wherein the processor signals to the beamer in accordance with the timed beam firing sequence.
6. The apparatus of claim 5, wherein the memory to store instructions, which when executed by the processor, causes the processor to signal to the receiver to receive and process data signals in accordance with the timed beam firing sequence.
 7. The apparatus of claim 6, wherein the receiver processes the data signals by performing at least one of: analog-to-digital conversion, noise reduction or noise filtering.
 8. The apparatus of claim 5, wherein the processor to signal to the beamer to generate signals to the at least one probe unit associated with the plurality of task actions further comprises:
 - the beamer transmitting the signals to the probe interface, and
 - the probe interface transmitting the signals to the at least one probe unit, respectively.
 9. The apparatus of claim 5, wherein the signals cause the at least one probe unit to fire their beams, respectively.
 10. The apparatus of claim 9, wherein the beams include at least one of ultrasound beams or a laser beam.
 11. The apparatus of claim 10, wherein the ultrasound beams include at least one of Doppler beams or B-Mode beams.
 12. The apparatus of claim 6, wherein the memory to store instructions, which when executed by the processor, causes the processor:
 - to analyze the processed data signals received from the receiver,
 - to modify the timed beam firing sequence, wherein modifying the timed beam firing sequence includes at least one of: adding task actions to the task list, or deleting task actions from the task list, and
 - to signal to the beamer to generate signals to the at least one probe unit associated with the modified timed beam firing sequence, wherein the processor signals to the beamer in accordance to the modified timed beam firing sequence.
 13. The apparatus of claim 5, wherein the memory to store instructions, which when executed by the processor, causes the processor:
 - to receive the timed beam firing sequence from an input device,
 - to add task actions included in the timed beam firing sequence to the task list, wherein the task list includes a plurality of tasks actions scheduled to be performed by an ultrasound system.

14. The apparatus of claim 12, wherein the memory to store instructions, which when executed by the processor, causes the processor:
- to delete task actions from the task list.
15. The apparatus of claim 12, wherein the memory to store instructions, which when executed by the processor, causes the processor:
- to select a next task in the task list,
 - to determine if a task action included in the next task can start, wherein determining if the task action can start includes determining if the task action can be completed without interfering with a start of a higher priority task in the task list,
 - to signal to a probe unit associated with the task action to start and perform the task action upon determination that the next task action can start,
 - to determine whether the end of the task list has been reached upon determination that the next task action cannot start; and
 - to select a task that follows the next task in the task list upon determination that the end of the task list has not been reached.

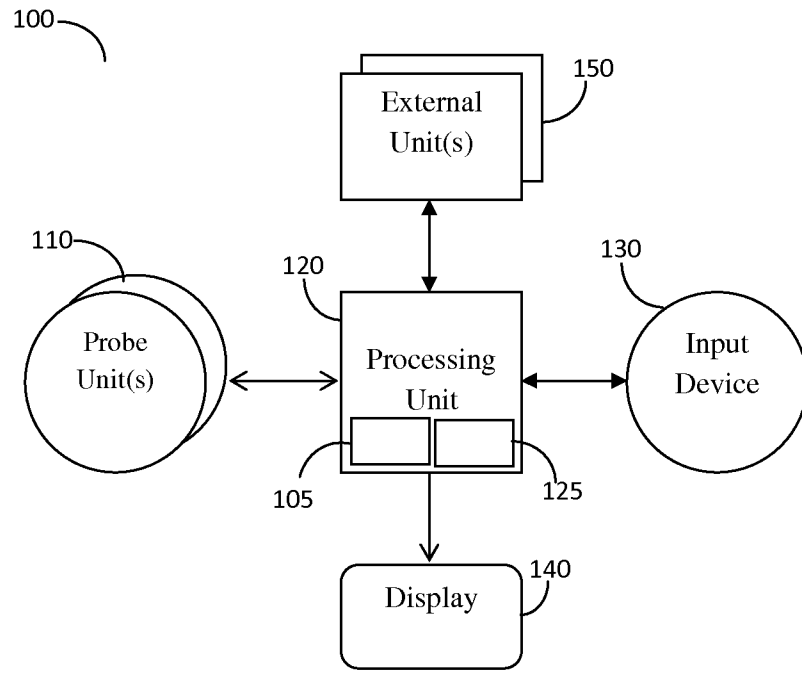

FIGURE 1

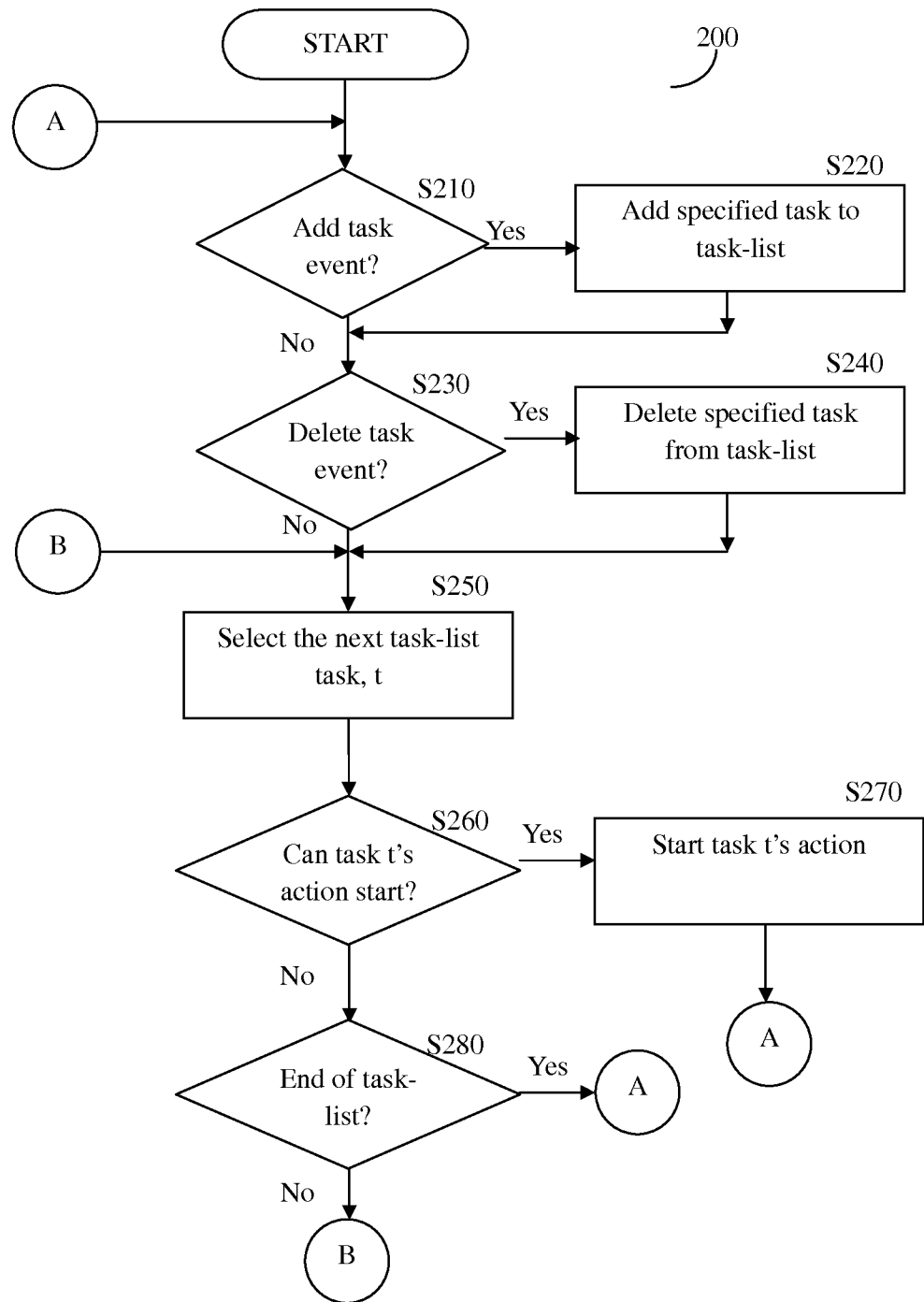

FIGURE 2

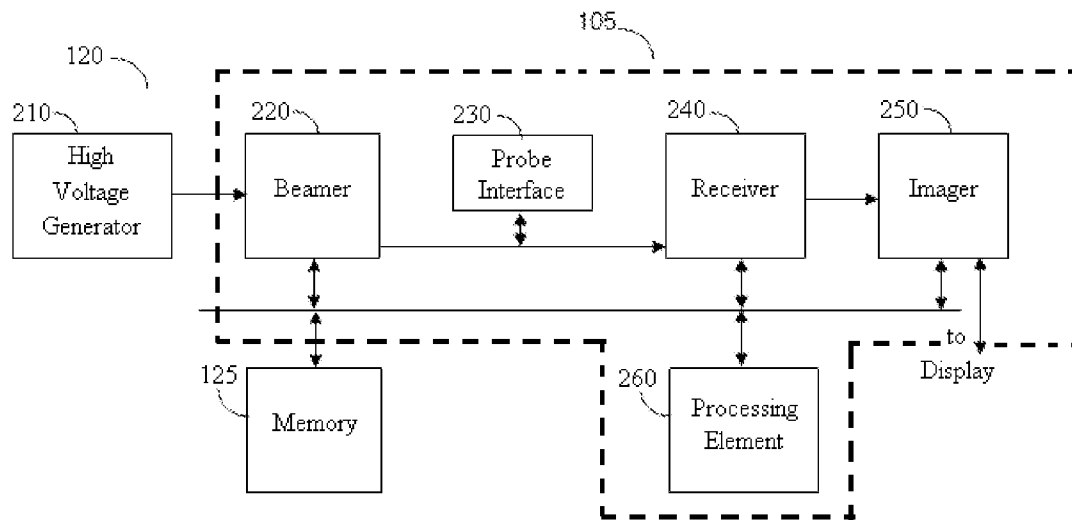

FIGURE 3

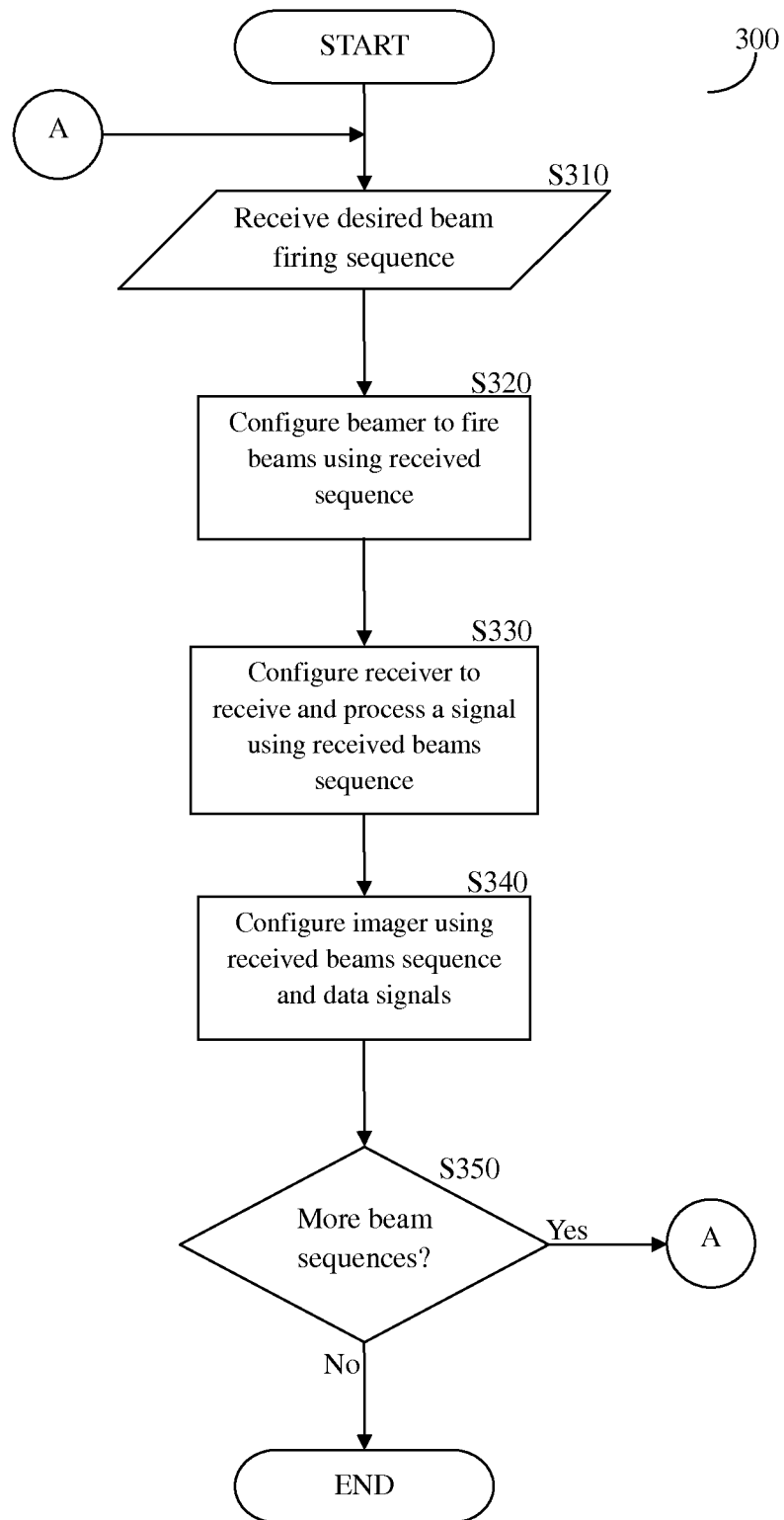

FIGURE 4

INTERNATIONAL SEARCH REPORT

International application No.

PCT/US2013/073554

A. CLASSIFICATION OF SUBJECT MATTER

IPC(8) - A61B 8/00 (2014.01)

USPC - 705/7.26

According to International Patent Classification (IPC) or to both national classification and IPC

B. FIELDS SEARCHED

Minimum documentation searched (classification system followed by classification symbols)

IPC(8) - 600/437, 440, 441; 705/2, 3, 7.13, 7.21, 7.22, 7.26; 706/45, 59 (2014.01)

USPC - A61B 8/00; G06F 17/00, 30

Documentation searched other than minimum documentation to the extent that such documents are included in the fields searched

CPC - A61B 8/00, 54; G06F 17/00, 30 (2013.01)

Electronic data base consulted during the international search (name of data base and, where practicable, search terms used)

PatBase, Google Patents, Google

C. DOCUMENTS CONSIDERED TO BE RELEVANT

Category*	Citation of document, with indication, where appropriate, of the relevant passages	Relevant to claim No.
Y	US 2006/0004606 A1 (WENDL et al.) 05 January 2006 (05.01.2006) entire document	1-15
Y	US 2002/0198454 A1 (SEWARD et al.) 26 December 2002 (26.12.2002) entire document	1-15
Y	US 6,526,163 B1 (HALMANN et al.) 25 February 2003 (25.02.2003) entire document	7
A	US 5,709,209 A (FRIEMEL et al.) 20 January 1998 (20.01.1998) entire document	1-15
A	WO 2012/123942 A1 (TEPPER et al.) 20 September 2012 (20.09.2012) entire document	1-15

 Further documents are listed in the continuation of Box C.

* Special categories of cited documents:

"A" document defining the general state of the art which is not considered to be of particular relevance

"E" earlier application or patent but published on or after the international filing date

"L" document which may throw doubts on priority claim(s) or which is cited to establish the publication date of another citation or other special reason (as specified)

"O" document referring to an oral disclosure, use, exhibition or other means

"P" document published prior to the international filing date but later than the priority date claimed

"T" later document published after the international filing date or priority date and not in conflict with the application but cited to understand the principle or theory underlying the invention

"X" document of particular relevance; the claimed invention cannot be considered novel or cannot be considered to involve an inventive step when the document is taken alone

"Y" document of particular relevance; the claimed invention cannot be considered to involve an inventive step when the document is combined with one or more other such documents, such combination being obvious to a person skilled in the art

"&" document member of the same patent family

Date of the actual completion of the international search

10 February 2014

Date of mailing of the international search report

24 FEB 2014

Name and mailing address of the ISA/US

Mail Stop PCT, Attn: ISA/US, Commissioner for Patents
P.O. Box 1450, Alexandria, Virginia 22313-1450

Facsimile No. 571-273-3201

Authorized officer:

Blaine R. Copenheaver

PCT Helpdesk: 571-272-4300

PCT OSP: 571-272-7774

专利名称(译)	用于自适应地调度超声系统动作的装置，系统和方法		
公开(公告)号	EP2928378A4	公开(公告)日	2016-07-27
申请号	EP2013860141	申请日	2013-12-06
[标]申请(专利权)人(译)	白鹰声波科技公司		
申请(专利权)人(译)	白鹰SONIC TECHNOLOGIES , INC.		
当前申请(专利权)人(译)	白鹰SONIC科技股份有限公司.		
[标]发明人	TOBIAS RICHARD WU BICHENG PARIKH ASHISH		
发明人	TOBIAS, RICHARD WU, BICHENG PARIKH, ASHISH		
IPC分类号	A61B8/00 G01S7/52 G01S15/89		
CPC分类号	G10K11/18 B06B1/0207 F04C2270/041 G01S7/52082 G01S7/52085 G01S7/52098 G01S15/8979 G01S15/899		
优先权	61/734291 2012-12-06 US 61/734067 2012-12-06 US		
其他公开文献	EP2928378A1		
外部链接	Espacenet		

摘要(译)

自适应调度超声设备动作的方法从包括在自适应调度器中的电子电路开始，该自适应调度器选择任务列表中的下一个任务。任务列表可以包括预定由超声系统执行的任务。每个任务可以包括多个任务动作。然后，电子电路可以确定下一个任务中包括的任务动作是否可以开始。该确定可以包括确定是否可以完成任务动作而不干扰任务列表中的较高优先级任务的开始。当电子电路确定下一个任务动作可以开始时，电子电路可以向与任务动作相关联的波束发信号以开始并执行任务动作。还公开了其他实施例。