

(19)



(11)

**EP 3 167 811 B1**

(12)

**EUROPEAN PATENT SPECIFICATION**

(45) Date of publication and mention of the grant of the patent:  
**13.03.2019 Bulletin 2019/11**

(51) Int Cl.:  
**A61B 8/12 (2006.01)**      **A61B 1/00 (2006.01)**  
**A61B 1/018 (2006.01)**      **A61B 8/00 (2006.01)**

(21) Application number: **16197688.1**

(22) Date of filing: **07.11.2016**

**(54) ULTRASONIC ENDOSCOPE AND METHOD OF MANUFACTURING THE SAME**

ULTRASCHALLENDSKOP UND VERFAHREN ZUR HERSTELLUNG DAVON  
ENDOSCOPE ULTRASONIQUE ET SON PROCÉDÉ DE FABRICATION

(84) Designated Contracting States:  
**AL AT BE BG CH CY CZ DE DK EE ES FI FR GB GR HR HU IE IS IT LI LT LU LV MC MK MT NL NO PL PT RO RS SE SI SK SM TR**

(30) Priority: **09.11.2015 JP 2015219041**  
**10.11.2015 JP 2015220042**

(43) Date of publication of application:  
**17.05.2017 Bulletin 2017/20**

(62) Document number(s) of the earlier application(s) in accordance with Art. 76 EPC:  
**16197600.6 / 3 165 171**

(73) Proprietor: **Fujifilm Corporation**  
**Minato-ku**  
**Tokyo (JP)**

(72) Inventor: **MORIMOTO, Yasuhiko**  
**Kanagawa, 258-8538 (JP)**

(74) Representative: **Klunker IP**  
**Patentanwälte PartG mbB**  
**Destouchesstraße 68**  
**80796 München (DE)**

(56) References cited:  
**WO-A1-2015/053044**      **JP-A- H0 975 345**  
**US-A- 6 149 598**      **US-A1- 2014 058 269**

**EP 3 167 811 B1**

Note: Within nine months of the publication of the mention of the grant of the European patent in the European Patent Bulletin, any person may give notice to the European Patent Office of opposition to that patent, in accordance with the Implementing Regulations. Notice of opposition shall not be deemed to have been filed until the opposition fee has been paid. (Art. 99(1) European Patent Convention).

## Description

### BACKGROUND OF THE INVENTION

#### Field of the Invention

**[0001]** The present invention relates to an ultrasonic endoscope, and particularly relates to an ultrasonic endoscope including an ultrasonic observation unit provided to a distal end part body of an insertion unit, and a method of manufacturing the same.

#### Description of the Related Art

**[0002]** Japanese Patent Application Laid-Open No. 2013-27695 discloses an ultrasonic observation device (ultrasonic endoscope) including an ultrasonic communication unit (ultrasonic observation unit) provided to a distal end part of an insertion unit inserted into the inside of a body.

**[0003]** The ultrasonic communication unit of Japanese Patent Application Laid-Open No. 2013-27695 is provided with a plurality of piezoelectric elements arrayed in a convex circular arc shape. The surface of the piezoelectric element functions as an observation surface through which ultrasonic waves are communicated. An acoustic lens for converging an ultrasonic beam is provided on the top surface of the observation surface through an acoustic matching layer. A backing material is provided on the bottom surface of the observation surface of the piezoelectric element.

**[0004]** Each piezoelectric element is provided with an electrode, and the electrode is connected with a wiring connection unit through a flexible printed board. Typically, the wiring connection unit is provided on the bottom surface of the backing material. The wiring connection unit is connected with a plurality of wires for supplying a drive voltage to the respective piezoelectric elements. These wires are housed in a wire housing space provided to an ultrasonic-oscillator housing part housing an ultrasonic oscillator. The wire housing space is provided on a side on which the bottom surface of the ultrasonic oscillator is housed. In the present specification, the ultrasonic oscillator also refers to the piezoelectric elements and the backing material, and the bottom surface of the ultrasonic oscillator refers to the bottom surface of the backing material.

**[0005]** An ultrasonic endoscope according to the preamble of claim 1 is known from WO 2015/053044 A1. On the bottom side of the ultrasonic oscillator there is provided a wiring holder which is in contact with side surfaces of the ultrasonic-oscillator housing part, while the bottom surface of the wiring holder forms a gap with respect to the bottom of the ultrasonic-oscillator housing part so as to receive wirings.

**[0006]** Japanese Patent Application Laid-Open No. 2013-27695 discloses that the acoustic lens is bonded to the ultrasonic communication unit (ultrasonic oscilla-

tor), and the ultrasonic communication unit to which the acoustic lens is bonded is assembled to a holding unit (ultrasonic-oscillator housing part) provided to the distal end part of the insertion unit.

**[0007]** Recently, an ultrasonic endoscope has been used in clinical practice that allows observation of the state of the inside of a subject body by irradiating the inside of the body with ultrasonic waves and receiving the reflected waves for imaging.

**[0008]** Such an ultrasonic endoscope includes an ultrasonic probe (ultrasonic observation unit) provided to a distal end rigid part at the distal end of the insertion unit inserted into the inside of the body as disclosed in, for example, Japanese Patent Application Laid-Open No. 2002-113005. Typically, the ultrasonic probe includes, for example, an acoustic lens, a piezoelectric element, and a backing material, and is fixed to an ultrasonic-oscillator housing part provided to the distal end rigid part. The ultrasonic probe transmits and receives ultrasonic waves toward and from an observation region inside the body so as to acquire a signal for generating an ultrasonic image.

**[0009]** The distal end rigid part is provided with a surgical-tool guide opening on a proximal end side thereof. The surgical-tool guide opening is communicated with a surgical tool channel arranged inside the insertion unit, and a surgical tool inserted into the surgical tool channel is guided out of the surgical-tool guide opening. This configuration allows the ultrasonic observation unit to acquire the position of the surgical tool during an ultrasonic observation.

### SUMMARY OF THE INVENTION

**[0010]** The plurality of wires housed in the wire housing space of the ultrasonic-oscillator housing part are fixed to the wire housing space by filling agent that fills the wire housing space so as to avoid breaking.

**[0011]** In the technology disclosed in Japanese Patent Application Laid-Open No. 2013-27695, when the ultrasonic communication unit is assembled to the holding unit (ultrasonic-oscillator housing part), a gap formed between the ultrasonic communication unit and the holding unit is filled with sealing agent so as to prevent liquid from flowing into the inside of the holding unit (achieve liquid-tightness).

**[0012]** However, in the technology disclosed in Japanese Patent Application Laid-Open No. 2013-27695, when the sealing agent that fills the gap formed between the ultrasonic communication unit and the holding unit flows into the wire housing space, the filling agent to fix the wires insufficiently fills the wire housing space, which makes it difficult to sufficiently fix the wires.

**[0013]** The present invention is intended to solve such a problem, and it is an object of the present invention to provide an ultrasonic endoscope in which wiring can be reliably fixed in a wire housing space of an ultrasonic-oscillator housing part, and a method of manufacturing

the ultrasonic endoscope.

**[0014]** The surgical tool guided out of the surgical-tool guide opening needs to be accurately guided into an ultrasonic observation region to achieve a favorable ultrasonic observation using the ultrasonic endoscope, which requires a high accuracy of positioning the ultrasonic probe with respect to the surgical-tool guide opening.

**[0015]** However, Japanese Patent Application Laid-Open No. 2002-113005 provides no consideration on the above-described problem, and no means for solving the problem.

**[0016]** The following describes in detail the structure of an ultrasonic endoscope disclosed in Japanese Patent Application Laid-Open No. 2002-113005. An ultrasonic probe of the ultrasonic endoscope of Japanese Patent Application Laid-Open No. 2002-113005 is provided in an opening (ultrasonic-oscillator housing part) of an exterior case (distal end part body) provided to a distal end of a distal end rigid part thereof. The ultrasonic probe includes an acoustic lens, a second acoustic matching layer, a first acoustic matching layer, a piezoelectric element, and a backing material stacked on an outer surface in this order. The piezoelectric element is surrounded by a backing frame, and this backing frame is filled with the backing material, serving as a backing unit. The backing frame is engaged with an exterior member, and then this exterior member is fitted into the opening (ultrasonic-oscillator housing part) and bonded thereto. With this configuration, the ultrasonic probe is fixed to the opening (ultrasonic-oscillator housing part).

**[0017]** Since the ultrasonic endoscope of Japanese Patent Application Laid-Open No. 2002-113005 has the structure that the exterior member engaged with the backing frame is bonded to the opening (ultrasonic-oscillator housing part) in a simple manner, Japanese Patent Application Laid-Open No. 2002-113005 provides no consideration on adjustment of the position of the ultrasonic probe with respect to the surgical-tool guide opening, and provides no device to accurately and easily adjust the position. Thus, in the ultrasonic endoscope of Japanese Patent Application Laid-Open No. 2002-113005, the position of the exterior member is likely to shift with respect to the opening (ultrasonic-oscillator housing part). This positional shift degrades the accuracy of positioning the ultrasonic probe with respect to the surgical-tool guide opening, which indicates that the structure is unsuitable for performing a favorable ultrasonic observation.

**[0018]** The present invention is intended to solve such problems, and it is an object of the present invention to provide an ultrasonic endoscope in which the position of an ultrasonic oscillator can easily adjusted with respect to a surgical-tool guide opening provided to a distal end part body of an insertion unit, and a method of manufacturing the ultrasonic endoscope.

**[0019]** To achieve the object of the present invention, an ultrasonic endoscope according to the present invention includes:

the features of claim 1.

**[0020]** To achieve the object of the present invention, a method of manufacturing an ultrasonic endoscope according to the present invention is a method of manufacturing an ultrasonic endoscope including: the features of claim 8.

**[0021]** According to the present invention, the position of the ultrasonic oscillator can be adjusted with respect to the ultrasonic-oscillator housing part through the spacer, and thus the position of the ultrasonic oscillator can be easily adjusted with respect to the surgical-tool guide opening provided to the distal end part body of the insertion unit. With this configuration, the ultrasonic endoscope according to the present invention allows a surgical tool to be accurately guided into an ultrasonic observation region, thereby achieving a favorable ultrasonic observation.

**[0022]** The acoustic lens according to the present invention covers the observation surface of the ultrasonic oscillator, and the spacer or the protrusion, and is adhered to the ultrasonic-oscillator housing part. In other words, a gap between the ultrasonic oscillator and the ultrasonic-oscillator housing part is sealed by part of the acoustic lens without using sealing agent.

**[0023]** In one aspect of the present invention, it is preferable that the spacer has a uniform thickness in a direction normal to a surface of the spacer, which is in contact with a corresponding one of the side surfaces of the ultrasonic oscillator when the ultrasonic oscillator is housed in the ultrasonic-oscillator housing part.

**[0024]** According to one aspect of the present invention, the spacer has a uniform thickness, and thus the ultrasonic oscillator can be accurately provided to the ultrasonic-oscillator housing part. A preferable uniform thickness of the spacer is a uniform thickness that provides parallelism enough to keep, inside the ultrasonic observation region, a surgical tool guided through the surgical-tool guide opening and entering into the ultrasonic observation region of the ultrasonic oscillator from a proximal side end face of the observation region. The ultrasonic observation region when viewed from the surgical-tool guide opening includes a region narrowed in a direction intersecting with the longitudinal axis of the insertion unit. The uniform thickness that provides parallelism enough to keep the surgical tool inside the ultrasonic observation region through the spacer is such a uniform thickness that the parallelism of side surfaces parallel to the longitudinal axis of the insertion unit among the side surfaces of the ultrasonic oscillator with respect to the guide direction of the surgical tool can be provided through the spacer so as to keep the surgical tool inside the narrowed region.

**[0025]** In another aspect of the present invention, it is preferable that the spacer is provided between the ultrasonic-oscillator housing part and a side surface parallel to the longitudinal axis of the insertion unit among the side surfaces of the ultrasonic oscillator.

**[0026]** According to one aspect of the present inven-

tion, a constant gap can be held through the spacer between the ultrasonic-oscillator housing part and the side surface parallel to the longitudinal axis of the insertion unit among the side surfaces of the ultrasonic oscillator.

**[0027]** In another aspect of the present invention, it is preferable that the spacers are provided between the ultrasonic-oscillator housing part and two side surfaces parallel to the longitudinal axis of the insertion unit and facing to each other among the side surfaces of the ultrasonic oscillator, and that when the ultrasonic oscillator is housed in the ultrasonic-oscillator housing part, the spacers provided between the ultrasonic-oscillator housing part and the two side surfaces have thicknesses equal to each other, each thickness being measured in a direction normal to a surface of the spacer, which is in contact with a corresponding one of the side surfaces of the ultrasonic oscillator.

**[0028]** According to one aspect of the present invention, the two side surfaces parallel to the longitudinal axis of the insertion unit and facing to each other among the side surfaces of the ultrasonic oscillator can be arranged in parallel to the longitudinal axis of the insertion unit through the spacers or the protrusions. In the aspect of the present invention, the thickness of a spacer or a protrusion in a normal direction is such a thickness that achieves electrical insulation through the spacer and a small outer shape of the distal end part body. Thicknesses in the normal direction are said to be equal to each other with any variation in manufacturing the spacer or the protrusion.

**[0029]** In another aspect of the present invention, it is preferable that the spacer is provided between the ultrasonic-oscillator housing part and a side surface intersecting with the longitudinal axis of the insertion unit among the side surfaces of the ultrasonic oscillator.

**[0030]** According to one aspect of the present invention, a constant gap can be held through the spacer between the ultrasonic-oscillator housing part and the side surface intersecting with the longitudinal axis of the insertion unit among the side surfaces of the ultrasonic oscillator.

**[0031]** In another aspect of the present invention, it is preferable that the spacers are provided between the ultrasonic-oscillator housing part and two side surfaces intersecting with the longitudinal axis of the insertion unit and facing to each other among the side surfaces of the ultrasonic oscillator, and that when the ultrasonic oscillator is housed in the ultrasonic-oscillator housing part, the spacers provided between the ultrasonic-oscillator housing part and the two side surfaces have thicknesses equal to each other, each thickness being measured in a direction normal to a surface of the spacer, which is in contact with a corresponding one of the side surfaces of the ultrasonic oscillator.

**[0032]** According to one aspect of the present invention, the two side surfaces intersecting with the longitudinal axis of the insertion unit and facing to each other among the side surfaces of the ultrasonic oscillator can

be arranged in a direction intersecting with the longitudinal axis of the insertion unit through the spacers. In another aspect of the present invention, it is preferable that the spacer is elastic in a thickness direction corresponding to in the normal direction.

**[0033]** According to one aspect of the present invention, the spacer is elastic, and thus can cancel any error in the dimensions of the ultrasonic oscillator and the ultrasonic-oscillator housing part through elastic deformation thereof.

**[0034]** In another aspect of the present invention, it is preferable that the spacer is provided between the ultrasonic-oscillator housing part and the bottom surface of the ultrasonic oscillator.

**[0035]** According to one aspect of the present invention, the bottom surface of the ultrasonic oscillator can be supported with respect to the ultrasonic-oscillator housing part through the another spacer.

**[0036]** According to one aspect of the present invention, the spacer serves as a weir, thereby preventing melted resin of the acoustic lens from flowing into the wiring connection unit when the acoustic lens is shaped.

#### BRIEF DESCRIPTION OF THE DRAWINGS

##### **[0037]**

Fig. 1 is an entire configuration diagram of an ultrasonic examination system including an ultrasonic endoscope according to an embodiment;

Fig. 2 is a block diagram illustrating the entire configuration of the ultrasonic examination system in Fig. 1;

Fig. 3 is an enlarged sectional view illustrating a main part of a distal end structure of an insertion unit of the ultrasonic endoscope illustrated in Fig. 1;

Fig. 4 is a perspective view of a distal end rigid part of the ultrasonic endoscope;

Fig. 5 is a plan view of the distal end rigid part of the ultrasonic endoscope;

Fig. 6 is a side view of the distal end rigid part of the ultrasonic endoscope;

Fig. 7 is a front view of the distal end rigid part of the ultrasonic endoscope;

Fig. 8 is a diagram illustrating assembly of an ultrasonic oscillator to the distal end part body;

Fig. 9 is a sectional view of the distal end part body and the ultrasonic oscillator taken along line IX- IX in Fig. 4;

Fig. 10 is a plan view of the ultrasonic oscillator;

Fig. 11 is a flowchart of a method of manufacturing an ultrasonic endoscope according to the present embodiment;

Fig. 12 is a diagram illustrating assembly of an ultrasonic oscillator to the distal end part body;

Fig. 13 is a sectional view of the distal end part body and the ultrasonic oscillator taken along line IX- IX in Fig. 4;

Fig. 14 is a plan view of the ultrasonic oscillator;  
 Fig. 15 is a flowchart of a method of manufacturing an ultrasonic endoscope according to the present embodiment;  
 Fig. 16 is a perspective view of the ultrasonic oscillator, illustrating positioning of the ultrasonic oscillator with respect to the ultrasonic-oscillator housing part through protrusions;  
 Fig. 17 is an exploded view of the ultrasonic oscillator in Fig. 16; and  
 Fig. 18 is a sectional view of the distal end part body including the ultrasonic oscillator in Fig. 16.

#### DETAILED DESCRIPTION OF THE PREFERRED EMBODIMENTS

**[0038]** Preferable embodiments of an ultrasonic endoscope according to the present invention and a method of manufacturing the ultrasonic endoscope will be described below in detail with reference to the accompanying drawings.

**[0039]** Fig. 1 is an entire configuration diagram of an ultrasonic examination system 1 including an ultrasonic endoscope 10 according to the present embodiment. Fig. 2 is a block diagram of the entire configuration of the ultrasonic examination system 1 illustrated in Fig. 1.

[Ultrasonic examination system 1]

**[0040]** The ultrasonic examination system 1 includes the ultrasonic endoscope 10 that captures an endoscopic image and an ultrasonic image of the inside of the body, an ultrasonic processor unit 12 that generates an ultrasonic image, an endoscopic processor unit 14 that generates an endoscopic image, a light source device 16 that supplies the ultrasonic endoscope 10 with illumination light that illuminates the inside of the body, and a monitor 18 that displays an endoscopic image and an ultrasonic image thereon.

[Ultrasonic endoscope 10]

**[0041]** The ultrasonic endoscope 10 is a convex ultrasonic endoscope including an insertion unit 22 inserted into the inside of the body, an operating unit 24 provided continuously with a proximal end of the insertion unit 22, and a universal cord 26 a proximal end of which is connected with the operating unit 24. A distal end of the universal cord 26 is provided with a connector 28 connected with the ultrasonic processor unit 12, a connector 30 connected with the endoscopic processor unit 14, and a connector 32 connected with the light source device 16. The ultrasonic endoscope 10 is detachably connected with the ultrasonic processor unit 12, the endoscopic processor unit 14, and the light source device 16 through the respective connectors 28, 30, and 32.

**[0042]** The ultrasonic processor unit 12, the endoscopic processor unit 14, and the light source device 16 are

loaded on a cart 20 with casters as illustrated in Fig. 1 and integrally moved. The monitor 18 is supported by a support 34 of the cart 20. The direction and height of a screen of the monitor 18 are adjusted through a rotation mechanism and a height adjusting mechanism (not illustrated) provided to the support 34.

<Insertion unit 22>

**[0043]** As illustrated in Fig. 2, the insertion unit 22 includes a distal end rigid part 40 including a distal end part body 70 (refer to Fig. 3) made of a rigid material, a curved part 42 provided continuously with a proximal end side of the distal end rigid part 40, and a flexible part 44 having flexibility and a small diameter and a long length and coupling a proximal end side of the curved part 42 and a distal end of the operating unit 24, in this order from its distal end. In other words, the distal end of the insertion unit 22 is provided with the distal end part body 70. A surgical-tool guide opening 54 to be described later is formed in the distal end part body 70 (refer to Fig. 3).

**[0044]** Fig. 3 is a main-part enlarged sectional view illustrating a non-angled state of the insertion unit 22 of the ultrasonic endoscope 10 illustrated in Fig. 1.

**[0045]** A surgical-tool insertion tube 88 is arranged inside of the insertion unit 22 so as to guide a surgical tool including a puncture needle 100 and a sheath 102 to the surgical-tool guide opening 54. A proximal end of the surgical-tool insertion tube 88 is connected with a surgical-tool insertion opening 24f provided to the operating unit 24 illustrated in Fig. 2, whereas a distal end thereof is connected with a proximal end of a connecting pipe 86 (refer to Fig. 3) arranged at a coupling position of the distal end rigid part 40 and the curved part 42. The connecting pipe 86 is made of metal such as stainless steel, mounted on the distal end part body 70 such that a distal end thereof is communicated with the surgical-tool guide opening 54. The surgical-tool insertion tube 88 is made of, for example, polytetrafluoroethylene (PTFE).

**[0046]** As illustrated in Fig. 2, the distal end part body 70 (refer to Fig. 3) of the distal end rigid part 40 is provided with an ultrasonic observation unit 50, an endoscope observation unit 52, and the surgical-tool guide opening 54.

**[0047]** The ultrasonic observation unit 50 includes an ultrasonic oscillator including an observation surface through which ultrasonic waves are communicated as described later. The ultrasonic observation unit 50 acquires an ultrasonic signal for generating as an ultrasonic image, a topographic image of cellular tissue existing deeper than a wall of the body cavity.

**[0048]** The endoscope observation unit 52 includes, for example, components of an observation optical system and an illumination optical system and an image pickup element and a peripheral circuit thereof as described later. The endoscope observation unit 52 optically captures the surface of a wall of the body cavity so as to acquire an image signal for displaying an endoscopic image for observation.

**[0049]** As illustrated in Fig. 3, the surgical-tool guide opening 54 guides, into the inside of the body, a distal end (a distal end 100a of the puncture needle 100 in Fig. 2) of the surgical tool including the puncture needle 100 and the sheath 102 inserted into the surgical-tool insertion tube 88. The surgical-tool guide opening 54 is communicated with a distal end of the connecting pipe 86, and an elevator 74 that changes a direction in which the puncture needle 100 is guided is provided closer to the distal end of the connecting pipe 86.

**[0050]** Although embodiment exemplarily describes the surgical tool including the puncture needle 100 and the sheath 102, the present invention is not limited thereto but is applicable to other surgical tools such as forceps.

<Operating unit 24>

**[0051]** As illustrated in Fig. 2, the operating unit 24 includes, for example, an angle knob 24a for curving the curved part 42 of the insertion unit 22 vertically and horizontally, an elevation lever 24b for standing up the elevator 74 (refer to Fig. 3), a suction button 24c for performing suction, an insufflation button 24d for performing air and water supply, and a plurality of operation members 24e for performing display switching of the monitor and instructions to freeze and release a display image. The surgical-tool insertion opening 24f for inserting various surgical tools into the surgical-tool insertion tube 88 (refer to Fig. 3) is provided as an extension closer to the distal end of the operating unit 24.

<Processor unit and the like>

**[0052]** The ultrasonic processor unit 12 transmits ultrasonic waves at a predetermined frequency from the observation surface toward an observation object by driving a piezoelectric element (to be described later) included in the ultrasonic observation unit 50. Then, the ultrasonic processor unit 12 receives, through the observation surface, ultrasonic waves reflected from the observation object and acquires, from the ultrasonic observation unit 50, an electric signal (ultrasonic signal) obtained from the received ultrasonic waves, and generates an image signal for an ultrasonic image by performing various kinds of signal processing on the electric signal.

**[0053]** The endoscopic processor unit 14 acquires the image signal transmitted from the image pickup element of the endoscope observation unit 52 of the ultrasonic endoscope 10 by performing drive control of the image pickup element, and generates an image signal for an endoscopic image by performing various kinds of signal processing on the image signal.

**[0054]** The light source device 16 supplies the illumination optical system with illumination light to be emitted from the illumination optical system of the distal end rigid part 40 for illuminating an observation view range of the endoscope observation unit 52.

**[0055]** The monitor 18 receives the image signals gen-

erated by the ultrasonic processor unit 12 and the endoscopic processor unit 14, and displays an ultrasonic image and an endoscopic image. In the display of these ultrasonic and endoscopic images, each of the images may be displayed on the monitor 18 in a switching manner as appropriate or both of the images may be simultaneously displayed on the monitor 18.

<Distal end rigid part 40>

**[0056]** Figs. 4, 5, 6, and 7 are a perspective view, a plan view, a side view, and a front view of the distal end rigid part 40, respectively.

**[0057]** As illustrated in these diagrams, the distal end part body 70 of the distal end rigid part 40 is provided with the ultrasonic observation unit 50, the endoscope observation unit 52, and the surgical-tool guide opening 54 as described above.

<Ultrasonic observation unit 50>

**[0058]** As illustrated in Fig. 3, the ultrasonic observation unit 50 is provided to the distal end part body 70. The ultrasonic observation unit 50 is provided with an ultrasonic oscillator 80.

**[0059]** Fig. 8 is a diagram illustrating assembly of the ultrasonic oscillator 80 to the distal end part body 70, Fig. 9 is a sectional view of the distal end part body 70 and the ultrasonic oscillator 80 taken along line IX-IX in Fig. 4, and Fig. 10 is a plan view of the ultrasonic oscillator 80.

**[0060]** As illustrated in these diagrams, the ultrasonic oscillator 80 includes an observation surface 80A through which ultrasonic waves are communicated, four side surfaces 80B, 80C, 80D, and 80E adjacent to the observation surface 80A, a bottom surface 80F opposite to the observation surface 80A, a plurality of plate piezoelectric elements 82 provided closer to the observation surface 80A, and a backing material 84 provided to the bottom surfaces of the plurality of piezoelectric elements 82. The four side surfaces are side surfaces of the backing material 84 formed in a semi-cylinder. Among the side surfaces, the side surfaces 80B and 80C are two side surfaces parallel to a longitudinal axis Z of the insertion unit 22 and facing to each other, and the side surfaces 80D and 80E are two side surfaces intersecting with the longitudinal axis Z of the insertion unit 22 and facing to each other.

**[0061]** The plurality of piezoelectric elements 82 are arrayed in the direction of the longitudinal axis Z of the insertion unit 22. In other words, the plurality of piezoelectric elements 82 are arrayed from a position close to a distal end of the distal end rigid part 40 toward the proximal end side of the distal end rigid part 40, and their surfaces serve as the observation surface 80A through which ultrasonic waves are communicated. The observation surface 80A is shaped as an arc surface in the direction of the longitudinal axis Z, but is not limited to this shape, and may be shaped as a curved surface hav-

ing a plurality of different curvatures. The observation surface 80A is provided, through an acoustic matching layer 91 (refer to Fig. 9), with an acoustic lens 90 for converging ultrasonic waves.

**[0062]** The plurality of piezoelectric elements 82 are each provided with an electrode (not illustrated), and the electrode is connected with a wiring connection unit 92 in Fig. 9 through a flexible printed board (not illustrated). The wiring connection unit 92 is provided in a central part of the bottom surface 80F of the ultrasonic oscillator 80, which is formed in a rectangle. The wiring connection unit 92 is connected with a plurality of narrow wires 94 for supplying a drive voltage to the plurality of piezoelectric elements 82, and these wires 94 are inserted into a wiring insertion hole 71 (refer to Fig. 3) of the distal end part body 70 and connected with the connector 28 in Fig. 2.

**[0063]** The ultrasonic observation unit 50 can perform ultrasonic electron scanning by supplying a drive voltage from the ultrasonic processor unit 12 to the plurality of piezoelectric elements 82 to sequentially drive the plurality of piezoelectric elements 82.

**[0064]** In Figs. 3 to 10, an X axis is defined to be a horizontal axis in a transverse direction orthogonal to the longitudinal axis Z, and a Y axis is defined to be a vertical axis in the vertical direction.

**[0065]** The distal end part body 70 is provided with an ultrasonic-oscillator housing part 96 with an opening upper part as illustrated in Fig. 8. The ultrasonic-oscillator housing part 96 includes side surfaces 96B (refer to Fig. 9), 96C, 96D, and 96E and a bottom surface 96F covering the side surfaces 80B, 80C, 80D, and 80E and the bottom surface 80F of the ultrasonic oscillator 80, thereby housing the ultrasonic oscillator 80.

**[0066]** A sealing member 98 is provided between the side surfaces 80B, 80C, 80D, and 80E of the ultrasonic oscillator 80 and the side surfaces 96B, 96C, 96D, and 96E of the ultrasonic-oscillator housing part 96.

[Sealing member 98]

**[0067]** The sealing member 98 is a frame member formed as an integration of the four sealing members 98B, 98C, 98D, and 98E. The sealing member 98B is provided between the side surface 80B of the ultrasonic oscillator 80 and the side surface 96B of the ultrasonic-oscillator housing part 96, the sealing member 98C is provided between the side surface 80C of the ultrasonic oscillator 80 and the side surface 96C of the ultrasonic-oscillator housing part 96, the sealing member 98D is provided between the side surface 80D of the ultrasonic oscillator 80 and the side surface 96D of the ultrasonic-oscillator housing part 96, and the sealing member 98E is provided between the side surface 80E of the ultrasonic oscillator 80 and the side surface 96E of the ultrasonic-oscillator housing part 96.

**[0068]** In other words, a gap between the side surface 80B of the ultrasonic oscillator 80 and the side surface

96B of the ultrasonic-oscillator housing part 96 is sealed by the sealing member 98B, a gap between the side surface 80C of the ultrasonic oscillator 80 and the side surface 96C of the ultrasonic-oscillator housing part 96 is sealed by the sealing member 98C, a gap between the side surface 80D of the ultrasonic oscillator 80 and the side surface 96D of the ultrasonic-oscillator housing part 96 is sealed by the sealing member 98D, and a gap between the side surface 80E of the ultrasonic oscillator 80 and the side surface 96E of the ultrasonic-oscillator housing part 96 is sealed by the sealing member 98E.

**[0069]** Although the present embodiment describes the example in which the sealing member 98 is provided to the ultrasonic oscillator 80, the sealing member 98 may be provided to the ultrasonic-oscillator housing part 96.

**[0070]** It is preferable that when the ultrasonic oscillator 80 is housed in the ultrasonic-oscillator housing part 96, the sealing member 98 having the above-described configuration has uniform thicknesses  $t_b$ ,  $t_c$ ,  $t_d$ , and  $t_e$  measured in directions (indicated by arrows B, C, D, and E) normal to surfaces of the sealing member 98, which are in contact with the side surfaces 80B, 80C, 80D, and 80E of the ultrasonic oscillator 80 as illustrated in Fig. 10.

**[0071]** It is preferable that the sealing member 98 is made of resin or rubber elastic in a thickness direction corresponding to each normal direction described above, and it is more preferable that the sealing member 98 is made of a thermoplastic resin material such as silicone, which is the same as that of the acoustic lens 90.

[Sealing member 110]

**[0072]** As illustrated in Figs. 8 and 9, a sealing member 110 is provided between the bottom surface 80F of the ultrasonic oscillator 80 and the bottom surface 96F of the ultrasonic-oscillator housing part 96.

**[0073]** The sealing member 110 includes four sealing members 110B, 110C, 110D, and 110E. The sealing member 110B supports part of the bottom surface 96F of the ultrasonic-oscillator housing part 96, which corresponds to the side surface 80B of the ultrasonic oscillator 80, the sealing member 110C supports part of the bottom surface 96F of the ultrasonic-oscillator housing part 96, which corresponds to the side surface 80C of the ultrasonic oscillator 80, the sealing member 110D supports part of the bottom surface 96F of the ultrasonic-oscillator housing part 96, which corresponds to the side surface 80D of the ultrasonic oscillator 80, and the sealing member 110E supports part of the bottom surface 96F of the ultrasonic-oscillator housing part 96, which corresponds to the side surface 80E of the ultrasonic oscillator 80. In other words, the sealing member 110 is provided in a peripheral part of the bottom surface 80F.

**[0074]** The ultrasonic oscillator 80 is housed in the ultrasonic-oscillator housing part 96 with its distal end being tilted downward, and thus the sealing members 110B and 110C are each formed in a triangle, the sealing mem-

ber 110D is formed in a rectangle, and the sealing member 110E is formed in a rectangle having a height larger than that of the sealing member 110D.

**[0075]** The sealing member 110 provides a wire housing space 112 in which the wires 94 are housed, between the bottom surface 80F of the ultrasonic oscillator 80 and the bottom surface 96F of the ultrasonic-oscillator housing part 96. In other words, the ultrasonic-oscillator housing part 96 includes the wire housing space 112 in which the wires 94 is housed, on a side on which the bottom surface 80F of the ultrasonic oscillator 80 is housed.

**[0076]** The sealing members 98 and 110 prevent melted thermoplastic resin of the acoustic lens 90 from flowing into the wire housing space 112 at formation of the acoustic lens 90 to be described later.

**[0077]** Similarly to the sealing member 98, it is preferable that the sealing member 110 is made of elastic resin or rubber, and it is more preferable that the sealing member 110 is made of a material such as silicone, which is the same as that of the acoustic lens 90.

[Acoustic lens 90]

**[0078]** The acoustic lens 90 covers the observation surface 80A of the ultrasonic oscillator 80 and the sealing member 98 and is adhered to the ultrasonic-oscillator housing part 96. A method of assembling the ultrasonic oscillator 80 to the ultrasonic-oscillator housing part 96 will be described later.

<<Endoscope observation unit 52>>

**[0079]** The endoscope observation unit 52 includes, for example, an observation optical system 62, illumination optical systems 64 and 66, and an image pickup element (not illustrated), and is provided to the distal end part body 70 on a proximal end side of the ultrasonic observation unit 50, avoiding the surgical-tool guide opening 54.

**[0080]** In the distal end part body 70, tilted surfaces 70a and 70b tilted at a predetermined angle with respect to a plane orthogonal to the longitudinal axis Z are provided at positions closer to the distal end than the surgical-tool guide opening 54 on both sides of the surgical-tool guide opening 54 in the traverse direction. An observation window 62a of the observation optical system 62 and an illumination window 64a of the illumination optical system 64 are arranged on the tilted surface 70a on the left side in the direction from the proximal end side toward the distal end side. An illumination window 66a of the illumination optical system 66 is arranged on the tilted surface 70b on the right side in the direction from the proximal end side toward the distal end side.

**[0081]** The observation optical system 62 includes an optical system member (not illustrated) that takes in light from an object in the observation view range through the observation window 62a and images an object image inside of the distal end rigid part 40. An image pickup

element (not illustrated) that captures the object image imaged by the observation optical system 62 and generates an image signal is arranged inside of the distal end rigid part 40.

**[0082]** The illumination optical systems 64 and 66 each include an optical system member that emits illumination light transmitted from the light source device 16 (refer to Fig. 2) through a light guide, to the observation view range through the illumination windows 64a and 66a in a diffusive manner.

**[0083]** A cleaning nozzle 68 that sprays liquid and gas toward the observation window 62a is provided near the observation window 62a on the tilted surface 70a.

15 <<Surgical-tool guide opening 54>>

**[0084]** The surgical-tool guide opening 54 includes a concave elevator housing part 72 provided on the proximal end side of the ultrasonic observation unit 50 and communicated with an opening 86a of the connecting pipe 86 in Fig. 3. The elevator 74, which changes the direction of guiding the puncture needle 100 guided through the opening 86a of the connecting pipe 86 from the surgical-tool guide opening 54, is rotatably provided to the elevator housing part 72.

**[0085]** The elevator 74 is coupled with a shaft provided to a lever (not illustrated). The lever is rotatably provided to the distal end part body 70 through the shaft and is coupled with a distal end of an operation wire (not illustrated), and a proximal end of the operation wire is coupled with the elevation lever 24b (refer to Fig. 2) of the operating unit 24. With this configuration, when the operation wire is pushed or pulled by operating the elevation lever 24b, the elevator 74 is rotated along with the lever through the shaft so as to change an angle at which the elevator 74 stands up.

**[0086]** Accordingly, the puncture needle 100 guided through the opening 86a of the connecting pipe 86 is guided in a predetermined guide direction along the elevator 74 to the outside through the surgical-tool guide opening 54.

[Method of assembling the ultrasonic oscillator 80 to the ultrasonic-oscillator housing part 96]

**[0087]** In the present embodiment, after the ultrasonic oscillator 80 to which the acoustic lens 90 is not provided is housed in the ultrasonic-oscillator housing part 96 of the distal end part body 70, the distal end part body 70 is loaded into a mold 114 (refer to Fig. 9), and then fluid melted resin (silicone resin) to be formed into the acoustic lens 90 through solidification is injected into the mold 114.

**[0088]** Fig. 11 is a flowchart of a method of manufacturing the ultrasonic endoscope 10 according to the present embodiment. The method of manufacturing the ultrasonic endoscope 10 according to the present embodiment performs step S10 of housing the ultrasonic oscillator 80 in the ultrasonic-oscillator housing part 96

and sealing a gap formed between the ultrasonic oscillator 80 and the ultrasonic-oscillator housing part 96 with the sealing members 98 and 110. Next, the method performs step S20 of shaping the acoustic lens 90 on the observation surface 80A of the ultrasonic oscillator with fluid resin and filling the gap between the ultrasonic oscillator 80 and the ultrasonic-oscillator housing part 96 with the resin while the gap is sealed by the sealing members 98 and 110.

**[0089]** Specifically, first, the ultrasonic oscillator 80 including the sealing members 98 and 110 is housed in the ultrasonic-oscillator housing part 96 of the distal end part body 70, and the wire housing space 112 is encapsulated from the outside in a liquid-tight manner by the sealing members 98 and 110 (S10). Next, the distal end part body 70 is fixed inside of the mold 114. Next, melted thermoplastic resin (not illustrated) is injected through an injection opening 116 of the mold 114. Next, the mold 114 is placed into a vacuum chamber (not illustrated) to perform defoaming of the melted thermoplastic resin. After the defoaming, the melted thermoplastic resin is injected into the mold 114 again to fill the inside of the mold 114 with the melted thermoplastic resin. Next, a plurality of molds are bonded to the mold so as to form a mold assembly. Next, the mold assembly is placed into a furnace so as to solidify the melted thermoplastic resin (S20). Thereafter, the mold assembly is taken out of the furnace and separated to obtain the distal end part body 70 out of the mold 114. Lastly, any unnecessary burr part around the acoustic lens 90 is removed.

**[0090]** The acoustic lens 90 covering the observation surface 80A of the ultrasonic oscillator 80 and the sealing member 98 and adhered to the ultrasonic-oscillator housing part 96 is shaped in this manner. In other words, in the process of providing the acoustic lens 90 on the observation surface 80A of the ultrasonic oscillator 80, the gap between the ultrasonic oscillator 80 and the ultrasonic-oscillator housing part 96 can be sealed by the acoustic lens 90.

**[0091]** The acoustic lens 90 according to the present embodiment covers the observation surface 80A of the ultrasonic oscillator 80 and the sealing member 98 and is adhered to the ultrasonic-oscillator housing part 96. In other words, in the endoscope observation unit 52 according to the present embodiment, the gap between the ultrasonic oscillator 80 and the ultrasonic-oscillator housing part 96 is sealed by part of the acoustic lens 90 without using sealing agent. Thus, in the endoscope observation unit 52 according to the present embodiment, the part of the acoustic lens 90 provides enhanced liquid-tightness of the ultrasonic observation unit 50 against the distal end part body 70.

[Effect of the sealing members 98 and 110]

**[0092]** In the present embodiment, the wire housing space 112 is encapsulated from the outside by sealing the gap formed between the ultrasonic oscillator 80 and

the ultrasonic-oscillator housing part 96 in a liquid-tight manner with the sealing members 98 and 110. With this configuration, the wire housing space 112 can be sufficiently filled with filling agent for fixing the wires 94 in the wire housing space 112. This achieves the ultrasonic endoscope 10 in which the wires 94 can be reliably fixed to the wire housing space 112 of the ultrasonic-oscillator housing part 96.

**[0093]** It is preferable that the sealing member 98 according to the present embodiment is provided between the side surfaces 80B to 80E of the ultrasonic oscillator 80 and the ultrasonic-oscillator housing part 96.

**[0094]** With this configuration, the wire housing space 112 can be encapsulated from the outside by the sealing member 98 provided between the side surfaces 80B to 80E of the ultrasonic oscillator 80 and the ultrasonic-oscillator housing part 96.

**[0095]** It is preferable that the sealing member 110 according to the present embodiment is provided between the bottom surface 80F of the ultrasonic oscillator 80 and the ultrasonic-oscillator housing part 96.

**[0096]** With this configuration, the wire housing space 112 can be encapsulated from the outside by the sealing member 110 provided between the bottom surface 80F of the ultrasonic oscillator 80 and the ultrasonic-oscillator housing part 96.

**[0097]** It is preferable that the acoustic lens 90 made of resin according to the present embodiment is made of thermoplastic resin.

**[0098]** With this configuration, the acoustic lens 90 can be shaped by loading the ultrasonic-oscillator housing part 96 into the mold and injecting melted thermoplastic resin to be formed as the acoustic lens 90 into the mold while the ultrasonic oscillator 80 is housed in the ultrasonic-oscillator housing part 96. The fluid melted thermoplastic resin thus injected is prevented from flowing into the wire housing space 112 by the sealing members 98 and 110, and thus the wire housing space 112 can be sufficiently filled with filling agent for fixing the wires 94 in the wire housing space 112.

**[0099]** In the above-described embodiment, the two sealing members 98 and 110 are provided, but at least one sealing member of the two sealing members 98 and 110 may be provided.

**[0100]** In the above-described embodiment, the acoustic lens 90 is formed integrally with the ultrasonic oscillator 80 by the molding technology, but the ultrasonic oscillator may be bonded with a previously manufactured acoustic lens and then assembled to the ultrasonic-oscillator housing part.

**[0101]** As disclosed in Fig. 12, a spacer 198 is provided between the side surfaces 80B, 80C, 80D, and 80E of the ultrasonic oscillator 80 and the side surfaces 96B, 96C, 96D, and 96E of the ultrasonic-oscillator housing part 96. The position of the ultrasonic oscillator 80 is adjusted with respect to the ultrasonic-oscillator housing part 96 through the spacer 198, and the position of the ultrasonic oscillator 80 is adjusted with respect to the

surgical-tool guide opening 54 (refer to Fig. 3) accordingly.

[Spacer 198]

**[0102]** The spacer 198 is a frame member formed as an integration of four spacers 198B, 198C, 198D, and 198E. The spacer 198B is provided between the side surface 80B of the ultrasonic oscillator 80 and the side surface 96B of the ultrasonic-oscillator housing part 96, the spacer 198C is provided between the side surface 80C of the ultrasonic oscillator 80 and the side surface 96C of the ultrasonic-oscillator housing part 96, the spacer 198D is provided between the side surface 80D of the ultrasonic oscillator 80 and the side surface 96D of the ultrasonic-oscillator housing part 96, and the spacer 198E is provided between the side surface 80E of the ultrasonic oscillator 80 and the side surface 96E of the ultrasonic-oscillator housing part 96.

**[0103]** In other words, an interval between the side surface 80B of the ultrasonic oscillator 80 and the side surface 96B of the ultrasonic-oscillator housing part 96 is accurately held by the spacer 198B, an interval between the side surface 80C of the ultrasonic oscillator 80 and the side surface 96C of the ultrasonic-oscillator housing part 96 is accurately held by the spacer 198C, an interval between the side surface 80D of the ultrasonic oscillator 80 and the side surface 96D of the ultrasonic-oscillator housing part 96 is accurately held by the spacer 198D, and an interval between the side surface 80E of the ultrasonic oscillator 80 and the side surface 96E of the ultrasonic-oscillator housing part 96 is accurately held by the spacer 198E. This configuration allows the position of the ultrasonic oscillator 80 to be accurately and easily adjusted with respect to the ultrasonic-oscillator housing part 96, and allows the position of the ultrasonic oscillator 80 to be accurately and easily adjusted with respect to the surgical-tool guide opening 54 (refer to Fig. 3).

**[0104]** Although the present embodiment describes the example in which the spacer 198 is provided to the ultrasonic oscillator 80, the spacer 198 may be provided to the ultrasonic-oscillator housing part 96. Although the present embodiment exemplarily describes the four spacers 198B, 198C, 198D, and 198E, at least one spacer is needed. The spacer is provided independently from the ultrasonic oscillator 80 and the ultrasonic-oscillator housing part 96, and attached to the ultrasonic oscillator 80 or the ultrasonic-oscillator housing part 96. The spacer is conceptually different from a protrusion to be described later in this point. Specifically, the protrusion is formed integrally with at least one of the ultrasonic oscillator 80 or the ultrasonic-oscillator housing part 96.

**[0105]** It is preferable that when the ultrasonic oscillator 80 is housed in the ultrasonic-oscillator housing part 96, the spacer 198 having the above-described configuration have uniform thicknesses  $t_b$ ,  $t_c$ ,  $t_d$ , and  $t_e$  measured in directions (indicated by arrows B, C, D, and E) normal to surfaces of the spacer 198, which are in contact with the

side surfaces 80B, 80C, 80D, and 80E of the ultrasonic oscillator 80 as illustrated in Fig. 14.

**[0106]** It is preferable that the spacer 198 is made of resin or rubber elastic in a thickness direction corresponding to each normal direction described above, and it is more preferable that the spacer 198 is made of a material such as silicone, which is that same as that of the acoustic lens 90.

10 [Spacer 1110]

**[0107]** As illustrated in Figs. 12 and 13, a spacer 1110 is provided between the bottom surface 80F of the ultrasonic oscillator 80 and the bottom surface 96F of the ultrasonic-oscillator housing part 96.

15 **[0108]** The spacer 1110 includes four spacers 1110B, 1110C, 1110D, and 1110E. The spacer 1110B supports part of the bottom surface 96F of the ultrasonic-oscillator housing part 96, which corresponds to the side surface 80B of the ultrasonic oscillator 80, the spacer 1110C supports part of the bottom surface 96F of the ultrasonic-oscillator housing part 96, which corresponds to the side surface 80C of the ultrasonic oscillator 80, the spacer 1110D supports part of the bottom surface 96F of the ultrasonic-oscillator housing part 96, which corresponds to the side surface 80D of the ultrasonic oscillator 80, and the spacer 1110E supports part of the bottom surface 96F of the ultrasonic-oscillator housing part 96, which corresponds to the side surface 80E of the ultrasonic oscillator 80. In other words, the spacer 1110 is provided in a peripheral part of the bottom surface 80F.

**[0109]** The ultrasonic oscillator 80 is housed in the ultrasonic-oscillator housing part 96 with its distal end being tilted downward, and thus the spacers 1110B and 1110C are each formed in a triangle, the spacer 1110D is formed in a rectangle, and the spacer 1110E is formed in a rectangle having a height larger than that of the spacer 1110D.

20 **[0110]** The spacer 1110 provides a space 112 in which the wires 94 are to be arranged, between the bottom surface 80F of the ultrasonic oscillator 80 and the bottom surface 96F of the ultrasonic-oscillator housing part 96. The spacers 198 and 1110 can prevent melted resin of the acoustic lens 90 from flowing into the space 112 at formation of the acoustic lens 90 to be described later.

25 **[0111]** Similarly to the spacer 198, it is preferable that the spacer 1110 is made of elastic resin or rubber, and it is more preferable that the spacer 1110 is made of a material such as silicone, which is the same as that of the acoustic lens 90.

[Acoustic lens 90]

30 **[0112]** The acoustic lens 90 covers the observation surface 80A of the ultrasonic oscillator 80 and the spacer 198, and is adhered to the ultrasonic-oscillator housing part 96. A method of assembling the ultrasonic oscillator 80 to the ultrasonic-oscillator housing part 96 will be de-

scribed later.

<<Endoscope observation unit 52>>

**[0113]** The endoscope observation unit 52 includes, for example, an observation optical system 62, illumination optical systems 64 and 66, and an image pickup element (not illustrated), and is provided to the distal end part body 70 on a proximal end side of the ultrasonic observation unit 50, avoiding the surgical-tool guide opening 54.

**[0114]** In the distal end part body 70, tilted surfaces 70a and 70b tilted at a predetermined angle with respect to a plane orthogonal to the longitudinal axis Z are provided at positions closer to the distal end than the surgical-tool guide opening 54 on both sides of the surgical-tool guide opening 54 in the traverse direction. An observation window 62a of the observation optical system 62 and an illumination window 64a of the illumination optical system 64 are arranged on the tilted surface 70a on the left side in the direction from the proximal end side toward the distal end side. An illumination window 66a of the illumination optical system 66 is arranged on the tilted surface 70b on the right side in the direction from the proximal end side toward the distal end side.

**[0115]** The observation optical system 62 includes an optical system member (not illustrated) that takes in light from an object in the observation view range through the observation window 62a and images an object image inside of the distal end rigid part 40. An image pickup element (not illustrated) that captures the object image imaged by the observation optical system 62 and generates an image signal is arranged inside of the distal end rigid part 40.

**[0116]** The illumination optical systems 64 and 66 each include an optical system member that emits illumination light transmitted from the light source device 16 (refer to Fig. 2) through a light guide, to the observation view range through the illumination windows 64a and 66a in a diffusive manner.

**[0117]** A cleaning nozzle 68 that sprays liquid and gas toward the observation window 62a is provided near the observation window 62a on the tilted surface 70a.

<<Surgical-tool guide opening 54>>

**[0118]** The surgical-tool guide opening 54 includes a concave elevation housing part 72 provided on the proximal end side of the ultrasonic observation unit 50 and communicated with an opening 86a of the connecting pipe 86 in Fig. 3. The elevator 74, which changes the direction of guiding the puncture needle 100 guided through the opening 86a of the connecting pipe 86 from the surgical-tool guide opening 54, is rotatably provided to the elevation housing part 72.

**[0119]** The elevator 74 is coupled with a shaft provided to a lever (not illustrated). The lever is rotatably provided to the distal end part body 70 through the shaft and is

coupled with a distal end of an operation wire (not illustrated), and a proximal end of the operation wire is coupled with the elevation lever 24b (refer to Fig. 2) of the operating unit 24. With this configuration, when the operation wire is pushed or pulled by operating the elevation lever 24b, the elevator 74 is rotated along with the lever through the shaft so as to change an angle at which the elevator 74 stands up.

**[0120]** Accordingly, the puncture needle 100 guided through the opening 86a of the connecting pipe 86 is guided in a predetermined guide direction along the elevator 74 to the outside through the surgical-tool guide opening 54.

[Method of assembling the ultrasonic oscillator 80 to the ultrasonic-oscillator housing part 96]

**[0121]** In the present embodiment, after the ultrasonic oscillator 80 to which the acoustic lens 90 is not provided is housed in the ultrasonic-oscillator housing part 96 of the distal end part body 70, the distal end part body 70 is loaded into a mold 114 (refer to Fig. 9), and then fluid melted resin (silicone resin) to be formed into the acoustic lens 90 through solidification is injected into the mold 114.

**[0122]** Fig. 15 is a flowchart of a method of manufacturing the ultrasonic endoscope 10 according to the present embodiment. The method of manufacturing the ultrasonic endoscope 10 according to the present embodiment performs step S110 of housing the ultrasonic oscillator 80 in the ultrasonic-oscillator housing part 96. Next, the method performs step S120 of temporarily fixing the ultrasonic oscillator 80 to the ultrasonic-oscillator housing part 96 while an extended line 54B of a center line 54A of the surgical-tool guide opening 54 is positioned in an observation region 81 of the ultrasonic oscillator 80 as illustrated in Fig. 3. Next, the method performs step S130 of shaping the acoustic lens 90 on the observation surface 80A of the ultrasonic oscillator 80 with fluid resin and filling a gap between the ultrasonic oscillator 80 and the ultrasonic-oscillator housing part 96 with the resin while the ultrasonic oscillator 80 is temporarily fixed.

**[0123]** Specifically, first, the ultrasonic oscillator 80 including the spacers 198 and 1110 is housed in the ultrasonic-oscillator housing part 96 of the distal end part body 70 (S110), and then the ultrasonic oscillator 80 is accurately positioned and temporarily fixed to the ultrasonic-oscillator housing part 96 through the spacers 198 and 1110 (S120). Next, the distal end part body 70 is fixed inside of the mold 114. Next, melted resin (not illustrated) is injected through an injection opening 116 of the mold 114. Next, the mold 114 is placed into a vacuum chamber (not illustrated) to perform defoaming of the melted resin. After the defoaming, the melted resin is injected into the mold 114 again to fill the inside of the mold 114 with the melted resin (S130). Next, a plurality of molds are bonded to the mold so as to form a mold assembly. Next, the mold assembly is placed into a furnace so as to solidify

the melted resin. Thereafter, the mold assembly is taken out of the furnace and separated to obtain the distal end part body 70 out of the mold 114. Lastly, any unnecessary burr around the acoustic lens 90 is removed.

**[0124]** The acoustic lens 90 covering the observation surface 80A of the ultrasonic oscillator 80 and the spacer 198 and adhered to the ultrasonic-oscillator housing part 96 is shaped in this manner. In other words, in the process of providing the acoustic lens 90 to the observation surface 80A of the ultrasonic oscillator 80, the gap between the ultrasonic oscillator 80 and the ultrasonic-oscillator housing part 96 is filled with the resin the acoustic lens 90.

**[0125]** According to the present embodiment, the position of the ultrasonic oscillator 80 can be accurately and easily adjusted through the spacer 198 with respect to the ultrasonic-oscillator housing part 96. Accordingly, in the ultrasonic endoscope 10 according to the present embodiment, the position of the ultrasonic oscillator 80 can be accurately and easily adjusted with respect to the surgical-tool guide opening 54. Thus, the ultrasonic endoscope 10 according to the present embodiment allows the puncture needle 100 as a surgical tool to be accurately guided into the ultrasonic observation region, thereby achieving a favorable ultrasonic observation.

**[0126]** The acoustic lens 90 according to the present embodiment covers the observation surface 80A of the ultrasonic oscillator 80 and the spacer 198 and is adhered to the ultrasonic-oscillator housing part 96. In other words, the gap between the ultrasonic oscillator 80 and the ultrasonic-oscillator housing part 96 is sealed by part of the acoustic lens 90 without using sealing agent. The part of the acoustic lens 90 provides enhanced watertightness of the ultrasonic observation unit 50 against the distal end part body 70.

[Effect of the spacers 198 and 1110]

**[0127]** The spacer 198 has the uniform thicknesses  $t_b$ ,  $t_c$ ,  $t_d$ , and  $t_e$  measured in the directions (indicated by arrows B, C, D, and E) normal to the surfaces of the spacer 198, which are in contact with the side surfaces 80B, 80C, 80D, and 80E of the ultrasonic oscillator 80 as illustrated in Fig. 14, when the ultrasonic oscillator 80 is housed in the ultrasonic-oscillator housing part 96. With this configuration, the ultrasonic oscillator 80 can be highly accurately housed in the ultrasonic-oscillator housing part 96.

**[0128]** Since the spacer 198 includes at least one spacer of the spacers 198B and 198C in contact with the side surfaces 80B and 80C, a constant gap can be held through at least one spacer between the ultrasonic-oscillator housing part 96 and at least one side surface of the side surfaces 80B to 80E of the ultrasonic oscillator 80, which is parallel to the longitudinal axis Z of the insertion unit 22.

**[0129]** In addition, since the spacer 198 includes the two spacers 198B and 198C in contact with the side surfaces 80B and 80C, a constant gap can be held through

the spacers 198B and 198C between the ultrasonic-oscillator housing part 96 and the side surfaces 80B and 80C parallel to the longitudinal axis Z of the insertion unit 22 among the side surfaces 80B to 80E of the ultrasonic oscillator 80.

**[0130]** In addition, in the above-described embodiment, it is preferable that the spacers 198B and 198C provided between the side surfaces 80B and 80C of the ultrasonic oscillator 80 and the side surfaces 96B and 96C of the ultrasonic-oscillator housing part 96 have thicknesses  $t_b$  and  $t_c$  equal to each other, each thickness being measured in a direction (illustrated by arrow B or C) normal to a surface of the spacer 198B or 198C, which is in contact with the corresponding side surface 80B or 80C of the ultrasonic oscillator 80. With this configuration, the two side surfaces 80B and 80C parallel to the longitudinal axis Z of the insertion unit 22 and facing to each other among the side surfaces 80B to 80E of the ultrasonic oscillator 80 can be arranged in parallel to the longitudinal axis Z of the insertion unit 22 through the spacers 198B and 198C.

**[0131]** In addition, it is preferable that the spacer 198 is provided between the side surfaces 80D and 80E intersecting with the longitudinal axis Z of the insertion unit 22 among the side surfaces 80B to 80E of the ultrasonic oscillator 80 and the side surfaces 96D and 96E of the ultrasonic-oscillator housing part 96. Thus, it is preferable that the spacer 198 includes at least one spacer of the spacers 198D and 198E in contact with the side surfaces 80D and 80E. With this configuration, a constant gap can be held through the spacer between the ultrasonic-oscillator housing part 96 and at least one side surface intersecting with the longitudinal axis Z of the insertion unit 22 among the side surfaces of the ultrasonic oscillator.

**[0132]** In addition, it is preferable that the spacer 198 is provided between the two side surfaces 80D and 80E intersecting with the longitudinal axis Z of the insertion unit 22 and facing to each other among the side surfaces 80B to 80E of the ultrasonic oscillator 80 and the side surfaces 96D and 96E of the ultrasonic-oscillator housing part 96. In other words, it is preferable that the spacer 198 includes the two spacers 198D and 198E in contact with the side surfaces 80D and 80E. With this configuration, a constant gap can be held through the spacers 198D and 198E between the ultrasonic-oscillator housing part 96 and the side surfaces 80D and 80E intersecting with the longitudinal axis Z of the insertion unit 22 among the side surfaces of the ultrasonic oscillator 80.

**[0133]** In the above-described embodiment, it is preferable that the spacers 198D and 198E provided between the two side surfaces 80D and 80E and the side surfaces 96D and 96E of the ultrasonic-oscillator housing part 96 have thicknesses  $t_d$  and  $t_e$  equal to each other, each being measured in a direction (illustrated by arrow D or E) normal to a surface of the spacer 198D or 198E, which is in contact with a corresponding one of the side surface 80D or 80E of the ultrasonic oscillator 80. With this configuration, the two side surfaces 80D and 80E

intersecting with the longitudinal axis Z of the insertion unit 22 and facing to each other among the side surfaces 80B to 80E of the ultrasonic oscillator 80 can be arranged in a direction intersecting with the longitudinal axis Z of the insertion unit 22 through the spacers 198D and 198E.

**[0134]** In addition, since the spacer 198 is made of resin or rubber elastic in the thickness direction corresponding to the above-described normal direction, any error in the dimensions of the ultrasonic oscillator 80 and the ultrasonic-oscillator housing part 96 can be canceled through elastic deformation of the spacer 198.

**[0135]** In addition, it is preferable that the spacer 1110 is provided between the bottom surface 80F of the ultrasonic oscillator 80 and the ultrasonic-oscillator housing part 96. With this configuration, the bottom surface 80F of the ultrasonic oscillator 80 can be supported with respect to the ultrasonic-oscillator housing part 96 through the spacer 1110.

**[0136]** In addition, in the present embodiment, it is preferable that the wiring connection unit 92 is provided in the central part of the bottom surface 80F of the ultrasonic oscillator 80, and the spacer 1110 is provided in the peripheral part of the bottom surface 80F. With this configuration, the spacer 1110 serves as a weir, thereby preventing melted resin of the acoustic lens 90 from flowing into the space 112 in which the wires 94 are arranged when the acoustic lens 90 is shaped.

**[0137]** In addition, since the spacer 1110 is made of elastic resin or rubber, any error in the dimensions of the ultrasonic oscillator 80 and the ultrasonic-oscillator housing part 96 can be canceled through elastic deformation of the spacer 1110.

**[0138]** In the above-described embodiment, the spacers 198 and 1110 are provided between the ultrasonic oscillator 80 and the ultrasonic-oscillator housing part 96, but in place of the spacers 198 and 1110, protrusions may be provided to at least one of the ultrasonic oscillator 80 and the ultrasonic-oscillator housing part 96.

**[0139]** Description of the configuration in which protrusions are provided in place of the spacers 198 and 1110 is equivalent to the above description with the spacers 198 and 1110 being replaced with protrusions. The same effect as that of the spacers 198 and 1110 is obtained.

**[0140]** The following describes the configuration in which protrusions are provided and the effect thereof, including duplicate description equivalent to the above description.

[Configuration in which protrusions are provided]

**[0141]** Figs. 16, 17, and 18 are a perspective view of the ultrasonic oscillator 80, an exploded view of the ultrasonic oscillator 80, and a sectional view of the distal end part body 70, respectively, illustrating positioning of the ultrasonic oscillator 80 with respect to the ultrasonic-oscillator housing part 96 through protrusions 120 and 122 in place of spacers.

**[0142]** A protrusion 120B of the protrusion 120 is pro-

vided on the side surface 80B of the ultrasonic oscillator 80, and has a function equivalent to that of the spacer 198B of the spacer 198 illustrated in Figs. 12 to 14.

**[0143]** A protrusion 120C of the protrusion 120 is provided on the side surface 80C of the ultrasonic oscillator 80, and has a function equivalent to that of the spacer 198C of the spacer 198.

**[0144]** A protrusion 120D of the protrusion 120 is provided on the side surface 80D of the ultrasonic oscillator 80, and has a function equivalent to that of the spacer 198D of the spacer 198.

**[0145]** A protrusion 120E of the protrusion 120 is provided on the side surface 80E of the ultrasonic oscillator 80, and has a function equivalent to that of the spacer 198E of the spacer 198.

**[0146]** A protrusion 122B of the protrusion 122 has a function equivalent to that of the spacer 1110B of the spacer 1110 illustrated in Fig. 12, a protrusion 122C of the protrusion 122 has a function equivalent to that of the spacer 1110C of the spacer 1110, a protrusion 122D of the protrusion 122 has a function equivalent to that of the spacer 1110D of the spacer 1110, and a protrusion 122E of the protrusion 122 has a function equivalent to that of the spacer 1110E of the spacer 1110. These protrusions 120 and 122 are formed integrally with the ultrasonic oscillator 80, but may be provided to the ultrasonic-oscillator housing part 96.

**[0147]** Thus, the configuration with the protrusions 120 and 122 illustrated in Figs. 16 to 18 achieves the same effect as that of the configuration with the spacers 198 and 1110 illustrated in Figs. 12 to 14.

**[0148]** In other words, the protrusion 120 has a uniform thickness in a direction normal to a surface of the protrusion 120, which is in contact with a corresponding one of the side surfaces 80B, 80C, 80D, and 80E of the ultrasonic oscillator 80, when the ultrasonic oscillator 80 is housed in the ultrasonic-oscillator housing part 96. With this configuration, the ultrasonic oscillator 80 can be accurately housed in the ultrasonic-oscillator housing part 96.

**[0149]** Since the protrusion 120 includes at least one protrusion of the protrusions 120B and 120C in contact with the side surface 80B as a first side surface and the side surface 80C as a second side surface, a constant gap can be held through the protrusion between the ultrasonic-oscillator housing part 96 and at least one side surface parallel to the longitudinal axis Z of the insertion unit 22 among the side surfaces of the ultrasonic oscillator 80.

**[0150]** In addition, since the protrusion 120 includes the two protrusions 120B and 120C in contact with the side surfaces 80B and 80C, a constant gap can be held through the protrusions 120B and 120C between the ultrasonic-oscillator housing part 96 and the side surfaces 80B and 80C parallel to the longitudinal axis Z of the insertion unit 22 among the side surfaces of the ultrasonic oscillator 80.

**[0151]** In addition, in the above-described embodi-

ment, it is preferable that the protrusions 120B and 120C provided between the side surfaces 80B and 80C of the ultrasonic oscillator 80 and the side surfaces 96B and 96C of the ultrasonic-oscillator housing part 96 have thicknesses equal to each other, each thickness being measured in a direction normal to a surface of the protrusion 120B or 120C, which is in contact with a corresponding one of the side surface 80B or 80C of the ultrasonic oscillator 80. With this configuration, the two side surfaces 80B and 80C parallel to the longitudinal axis Z of the insertion unit 22 and facing to each other among the side surfaces of the ultrasonic oscillator 80 can be arranged in parallel to the longitudinal axis Z of the insertion unit 22 through the protrusions 120B and 120C.

**[0152]** In addition, it is preferable that the protrusion 120 is provided between the side surfaces 96D and 96E of the ultrasonic-oscillator housing part 96 and the side surface 80D as a third side surface and the side surface 80E as a fourth side surface intersecting with the longitudinal axis Z of the insertion unit 22 among the side surfaces 80B to 80E of the ultrasonic oscillator 80. In other words, it is preferable that the protrusion 120 includes at least one protrusion of the protrusions 120D and 120E in contact with the side surfaces 80D and 80E. With this configuration, a constant gap can be held through the protrusion between the ultrasonic-oscillator housing part 96 and at least one side surface intersecting with the longitudinal axis Z of the insertion unit 22 among the side surfaces 80B to 80E of the ultrasonic oscillator 80.

**[0153]** In addition, it is preferable that the protrusion 120 is provided between the side surfaces 96D and 96E of the ultrasonic-oscillator housing part 96 and the two side surfaces 80D and 80E intersecting with the longitudinal axis Z of the insertion unit 22 and facing to each other among the side surfaces 80B to 80E of the ultrasonic oscillator 80. In other words, it is preferable that the protrusion 120 includes the two protrusions 120D and 120E in contact with the side surfaces 80D and 80E. With this configuration, a constant gap can be held through the protrusions 120D and 120E between the ultrasonic-oscillator housing part 96 and the side surfaces 80D and 80E intersecting with the longitudinal axis Z of the insertion unit 22 among the side surfaces 80B to 80E of the ultrasonic oscillator 80.

**[0154]** In the above-described embodiment, it is preferable that the protrusions 120D and 120E provided between the two side surfaces 80D and 80E and the side surfaces 96D and 96E of the ultrasonic-oscillator housing part 96 have thicknesses equal to each other, each thickness being measured in a direction normal to a surface of the protrusion 120D or 120E, which is in contact with a corresponding one of the side surface 80D or 80E of the ultrasonic oscillator 80. With this configuration, the two side surfaces 80D and 80E intersecting with the longitudinal axis Z of the insertion unit 22 and facing to each other among the side surfaces 80B to 80E of the ultrasonic oscillator 80 can be arranged in a direction inter-

secting with the longitudinal axis Z of the insertion unit 22 through the protrusions 120D and 120E.

**[0155]** In addition, since the protrusion 120 is made of resin or rubber elastic in the thickness direction corresponding to the above-described normal direction, any error in the dimensions of the ultrasonic oscillator 80 and the ultrasonic-oscillator housing part 96 can be canceled through elastic deformation of the protrusion 120.

**[0156]** In addition, it is preferable that the protrusion 122 is provided between the bottom surface 80F of the ultrasonic oscillator 80 and the ultrasonic-oscillator housing part 96. With this configuration, the bottom surface 80F of the ultrasonic oscillator 80 can be supported with respect to the ultrasonic-oscillator housing part 96 through the protrusion 122.

**[0157]** In addition, in the present embodiment, it is preferable that the wiring connection unit 92 is provided in the central part of the bottom surface 80F of the ultrasonic oscillator 80, and the protrusion 122 is provided in the peripheral part of the bottom surface 80F. With this configuration, the protrusion 122 serves as a weir, thereby preventing melted resin of the acoustic lens 90 from flowing into the space 112 in which the wires 94 are arranged when the acoustic lens 90 is shaped.

**[0158]** In addition, since the protrusion 122 is made of elastic resin or rubber, any error in the dimensions of the ultrasonic oscillator 80 and the ultrasonic-oscillator housing part 96 can be canceled through elastic deformation of the protrusion 122.

**[0159]** A preferable uniform thickness of the spacer 198 or the protrusion 120 is a uniform thickness that provides parallelism enough to keep, inside the ultrasonic observation region, the puncture needle 100 guided through the guide opening 54 and entering into the ultrasonic observation region of the ultrasonic oscillator 80 from a proximal end face of the observation region. The ultrasonic observation region when viewed from the guide opening 54 includes a region narrowed in a direction intersecting with the longitudinal axis of the insertion unit 22. The uniform thickness that provides parallelism enough to keep the puncture needle 100 inside the ultrasonic observation region through the spacer 198 or the protrusion 120 is such a uniform thickness that the parallelism of the side surfaces 80B and 80C, which are parallel to the longitudinal axis of the insertion unit 22 among the side surfaces of the ultrasonic oscillator 80, with respect to the guide direction of the puncture needle 100 can be provided through the spacer 198 or the protrusion 120 so as to keep the puncture needle 100 inside the narrowed region.

**[0160]** The thickness of the spacer 198 or the protrusion 120 in the normal direction is a thickness that achieves electrical insulation through the spacer 198 or the protrusion 120 and a small outer shape of the distal end part body 70. Thicknesses in the normal direction are said to be equal to each other with any variation in manufacturing the spacer 198 or the protrusion 120.

Claims

1. An ultrasonic endoscope (10) comprising:

an insertion unit (22) inserted into an inside of a body; 5  
 a distal end part body (70) provided to a distal end of the insertion unit and provided with a surgical-tool guide opening (54);  
 an ultrasonic observation unit (50) provided to the distal end part body(70); 10  
 an ultrasonic oscillator provided to the ultrasonic observation unit (50) and including an observation surface (80A) through which ultrasonic waves are communicated, side surfaces (80B-80E) adjacent to the observation surface(80A), a bottom surface (80I) opposite to the observation surface(80A), a piezoelectric element (82) provided closer to the observation surface(80A), and a backing material (84) provided to the bottom surface of the piezoelectric element (82); 20  
 an ultrasonic-oscillator housing part (96) provided to the distal end part body (70), covering the side surfaces and the bottom surface of the ultrasonic oscillator (80), and housing the ultrasonic oscillator (80); and 25  
 an acoustic lens (90) covering the observation surface (80A) of the ultrasonic oscillator (80), and adhered to the ultrasonic-oscillator housing part (96), 30  
 wherein  
 a spacer (198) is provided between at least one of the side surfaces of the ultrasonic oscillator (80) and the ultrasonic-oscillator housing part (96), and 35  
 wherein the acoustic lens (90) also covers the spacer (198),  
**characterized in that**  
 the spacer (198) has a uniform thickness in a direction normal to a surface of the spacer, which is in contact with a corresponding one of the side surfaces (96B, 96C) of the ultrasonic oscillator (80) when the ultrasonic oscillator is housed in the ultrasonic-oscillator housing part (96), and 40  
 the spacer (198) is elastic in a thickness direction corresponding to the normal direction. 45

2. The ultrasonic endoscope (10) according to claim 1, wherein

the spacer (198) is provided between the ultrasonic-oscillator housing part and a side surface parallel to a longitudinal axis of the insertion unit among the side surfaces of the ultrasonic oscillator. 50

3. The ultrasonic endoscope (10) according to claim 2, wherein

spacers are provided between the ultrasonic-oscillator housing part and two side surfaces parallel to the longitudinal axis of the insertion unit and facing to each other among the side surfaces of the ultrasonic oscillator, and when the ultrasonic oscillator (80) is housed in the ultrasonic-oscillator housing part, the spacers provided between the ultrasonic-oscillator housing part and the two side surfaces have thicknesses equal to each other, each thickness being measured in a direction normal to a surface of the spacer, which is in contact with a corresponding one of the side surfaces of the ultrasonic oscillator (80). 55

4. The ultrasonic endoscope according to any one of claims 1 to 3, wherein the spacer is provided between the ultrasonic-oscillator housing part and a side surface intersecting with the longitudinal axis of the insertion unit among the side surfaces of the ultrasonic oscillator (80).

5. The ultrasonic endoscope (10) according to claim 4, wherein

spacers are provided between the ultrasonic-oscillator housing part and two side surfaces intersecting with the longitudinal axis of the insertion unit and facing to each other among the side surfaces of the ultrasonic oscillator, and when the ultrasonic oscillator is housed in the ultrasonic-oscillator housing part, the spacers (198) provided between the ultrasonic-oscillator housing part and the two side surfaces have thicknesses equal to each other, each thickness being measured in a direction normal to a surface of the spacer, which is in contact with a corresponding one of the side surfaces of the ultrasonic oscillator. 60

6. The ultrasonic endoscope according to any one of claims 1 to 5, wherein

a further spacer (1110) is provided between the ultrasonic-oscillator housing part and the bottom surface of the ultrasonic oscillator (80). 65

7. The ultrasonic endoscope according to claim 6, further comprising a wiring connection unit provided to the ultrasonic oscillator (80) and connected with wiring for supplying a drive voltage to the ultrasonic oscillator (80),

wherein the wiring connection unit is provided in a central part of the bottom surface, and the further spacer (1110) is provided in a peripheral part of the bottom surface. 70

8. A method of manufacturing an ultrasonic endoscope (10) including an insertion unit (22) inserted into an

inside of a body, a distal end part body (70) provided to a distal end of the insertion unit (22) and provided with a surgical-tool guide opening (54), an ultrasonic observation unit (50) provided to the distal end part body (70), an ultrasonic oscillator (80) provided to the ultrasonic observation unit (50) and including an observation surface (80A) through which ultrasonic waves are communicated, side surfaces (80B-80E) adjacent to the observation surface, a bottom surface opposite to the observation surface (80A), a piezoelectric element (82) provided closer to the observation surface, and a backing material (84) provided to the bottom surface of the piezoelectric element (82), and an ultrasonic-oscillator housing part provided to the distal end part body and housing the ultrasonic oscillator, the method comprising:

housing the ultrasonic oscillator (80) in the ultrasonic-oscillator housing part (96) such that a spacer (198, 1110) is provided between at least one of the side surfaces (80B-80E) of the ultrasonic oscillator (80) and the ultrasonic-oscillator housing part (96), wherein the spacer has a uniform thickness in a direction normal to a surface of the spacer, which is in contact with a corresponding one of the side surfaces of the ultrasonic oscillator (80) when the ultrasonic oscillator is housed in the ultrasonic-oscillator housing part (96), the spacer being elastic in a thickness direction corresponding to the normal direction; temporarily fixing the ultrasonic oscillator (80) to the ultrasonic-oscillator housing part (96) while an extended line of a center line of the surgical-tool guide opening is positioned in an observation region of the ultrasonic oscillator (80); and shaping an acoustic lens (90) on the observation surface of the ultrasonic oscillator (80) with fluid resin and filling a gap between the ultrasonic oscillator and the ultrasonic-oscillator housing part with the resin while temporarily fixing the ultrasonic oscillator (80).

## Patentansprüche

### 1. Ultraschallendoskop (10), umfassend:

eine Einführeinheit (22), die in das Innere eines Körpers eingeführt wird;  
einen distalen Endteilkörper (70) am distalen Ende der Einführeinheit, ausgestattet mit einer Führungsöffnung (54) für ein chirurgisches Werkzeug;  
eine Ultraschall-Betrachtungseinheit (50), die an dem distalen Endteilkörper (70) vorgesehen ist;  
einen Ultraschalloszillator an der Ultraschall-Betrachtungseinheit (50), enthaltend eine Be-

trachtungsfläche (80A), durch die Ultraschallwellen kommuniziert werden, Seitenflächen (80B-80E) benachbart zu der Betrachtungsfläche (80A), eine Bodenfläche (80I) abgewandt von der Betrachtungsfläche (80A), ein piezoelektrisches Element (82), das näher an der Betrachtungsfläche (80A) vorgesehen ist, und ein Trägermaterial an der Bodenfläche des piezoelektrischen Elements (82);  
einen Ultraschalloszillator-Gehäuseteil (96) an dem distalen Endteilkörper (70), der die Seitenflächen und die Bodenfläche des Ultraschalloszillators (80) bedeckt und den Ultraschalloszillator (80) beherbergt; und  
eine akustische Linse (90), die die Betrachtungsfläche (80A) des Ultraschalloszillators (80) abdeckt und an dem Ultraschalloszillator-Gehäuseteil (96) haftet,  
wobei zwischen mindestens einer der Seitenflächen des Ultraschalloszillators (80) und dem Ultraschalloszillator-Gehäuseteil (96) ein Abstandshalter (198) angeordnet ist, und wobei die akustische Linse (90) außerdem den Abstandshalter (198) abdeckt,  
**dadurch gekennzeichnet, dass**  
der Abstandshalter eine gleichmäßige Dicke in einer Richtung normal zur Oberfläche des Abstandshalters besitzt, die in Berührung mit der entsprechenden Seitenfläche (96B, 96C) des Ultraschalloszillators (80) steht, wenn der Ultraschalloszillator in dem Ultraschalloszillator-Gehäuseteil (96) aufgenommen ist, und  
der Abstandshalter (198) in einer Dickenrichtung entsprechend der Normalenrichtung elastisch ist.

2. Ultraschallendoskop (10) nach Anspruch 1, bei dem der Abstandshalter (198) zwischen dem Ultraschalloszillator-Gehäuseteil und einer Seitenfläche parallel zu einer Längsachse der Einführeinheit von den Seitenflächen des Ultraschalloszillators vorgesehen ist.

3. Ultraschallendoskop (10) nach Anspruch 2, bei dem

Abstandshalter zwischen dem Ultraschalloszillator-Gehäuseteil und zwei Seitenflächen parallel zu der Längsachse der Einführeinheit und einander zugewandt unter den Seitenflächen des Ultraschalloszillators vorgesehen sind, und wenn der Ultraschalloszillator (60) in dem Ultraschalloszillator-Gehäuseteil aufgenommen ist, die Abstandshalter zwischen dem Ultraschalloszillator-Gehäuseteil und den beiden Seitenflächen gleiche Dicken besitzen, wobei jede Dicke in einer Richtung normal zu einer Oberfläche des Abstandshalters gemessen wird, die in Berührung mit einer entsprechenden Seitenflä-

che des Ultraschalloszillators (80) steht.

4. Ultraschallendoskop nach einem der Ansprüche 1 bis 3, bei dem der Abstandshalter zwischen dem Ultraschalloszillator-Gehäuseteil und einer Seitenfläche vor-gesehen ist, die sich mit der Längsachse des Einführteils schneidet, bezogen auf die Seitenflächen des Ultraschalloszillators (80). 5
5. Ultraschallendoskop (10) nach Anspruch 4, bei dem 10  
 Abstandshalter zwischen dem Ultraschalloszillator-Gehäuseteil und zwei Seitenflächen vor-gesehen sind, die die Längsachse des Einführteils schneiden und einander zugewandt sind unter den Seitenflächen des Ultraschalloszillators, und 15  
 wenn der Ultraschalloszillator in dem Ultraschalloszillator-Gehäuseteil aufgenom-men ist, die zwischen dem Ultraschalloszillator-Gehäuseteil und den beiden Seitenflächen vorhandenen Abstandshalter (198) einander gleichende Dicken aufweisen, wobei jede Dicke gemessen wird in einer Richtung normal zu einer Oberfläche des Abstandshalters, die in Berührung steht mit einer entsprechenden Seitenfläche des Ultraschalloszillators. 20  
 25
6. Ultraschallendoskop nach einem der Ansprüche 1 bis 5, bei dem ein weiterer Abstandshalter (1110) zwischen dem Ultraschalloszillator-Gehäuseteil und der Bodenfläche des Ultraschalloszillators (80) vor-gesehen ist. 30
7. Ultraschallendoskop nach Anspruch 6, weiterhin umfassend eine Verdrahtungs-verbindingseinheit, die an dem Ultraschalloszillator (80) vorgesehen ist und mit einer Verdrahtung zum Zuführen einer Treiberspannung zu dem Ultraschalloszillator (80) verbunden ist, 35  
 wobei die Verdrahtungsverbindingseinheit in einem zentralen Teil der Bodenfläche angeordnet ist, und der weitere Abstandshalter (1110) in einem Umfangsbereich der Bodenfläche vorgesehen ist. 40
8. Verfahren zum Fertigen eines Ultraschallendoskops (10), welches eine in das Innere eines Körpers einzuführende Einführeinheit (22) enthält, ferner einen distalen Endteilkörper (70) an einem distalen Ende der Einführeinheit (22) und ausgestattet mit einer Führungsöffnung (54) für ein chirurgisches Werkzeug, und mit einer Ultraschallbetrachtungseinheit (50) an dem distalen Endteilkörper (70), mit einem Ultraschalloszillator (80) in der Ultraschallbetrachtungseinheit (50) mit einer Betrachtungsfläche (80A), durch die hindurch Ultraschallwellen kommuniziert werden, Seitenflächen (80B-80E) benachbart zu der Betrachtungsfläche, einer Bodenfläche 45  
 50  
 55

abgewandt zu der Betrachtungsfläche (80A), mit einem piezoelektrischen Element (82) näher an der Betrachtungsfläche, und einem Trägermaterial (84) an der Bodenfläche des piezoelektrischen Elements (82), und mit einem Ultraschalloszillator-Gehäuseteil an dem distalen Endteilkörper zur Aufnahme des Ultraschalloszillators, umfassend:

Gehäusen des Ultraschalloszillators (80) in dem Ultraschalloszillator-Gehäuseteil (96) derart, dass zwischen mindestens einer der Seitenflächen (80B-80E) des Ultraschalloszillators (80) und dem Ultraschalloszillator-Gehäuseteil (96) ein Abstandshalter (198, 1110) vorgesehen ist, wobei der Abstandshalter eine gleichförmige Dicke in einer Richtung normal zu einer Oberfläche des Abstandshalters aufweist, die in Berührung mit einer entsprechenden Seitenfläche des Ultraschalloszillators (80) steht, wenn dieser in dem Ultraschalloszillator-Gehäuseteil (96) aufgenommen ist, wobei der Abstandshalter in einer Dickenrichtung entsprechend der Normalenrichtung elastisch ist; vorübergehendes Fixieren des Ultraschalloszillators (80) an dem Ultraschalloszillator-Gehäuseteil (96), während eine Verlängerungslinie einer Mittellinie der Führungsöffnung für ein chirurgisches Werkzeug in einer Betrachtungszone des Ultraschalloszillators (80) gelegen ist; und Formen einer akustischen Linse (90) auf der Betrachtungsfläche des Ultraschalloszillators (80) mit einem Fluid-Harz, und Ausfüllen einer Lücke zwischen dem Ultraschalloszillator und dem Ultraschalloszillator-Gehäuseteil mit dem Harz, während der Ultraschalloszillator (80) vorübergehend fixiert ist.

#### 40 Revendications

1. Endoscope à ultrasons (10), comprenant :

une unité d'introduction (22) introduite à l'intérieur d'un corps ;  
 un corps de partie d'extrémité distale (70) fourni sur une extrémité distale de l'unité d'introduction et doté d'une ouverture de guidage d'outil chirurgical (54) ;  
 une unité d'observation à ultrasons (50) fournie sur le corps de partie d'extrémité distale (70) ;  
 un oscillateur à ultrasons fourni sur l'unité d'observation à ultrasons (50) et incluant une surface d'observation (80A) par le biais de laquelle des ondes ultrasonores sont communiquées, des surfaces latérales (80B-80E) adjacentes à la surface d'observation (80A), une surface de fond (80I) face à la surface d'observation (80A),

- un élément piézoélectrique (82) fourni plus près de la surface d'observation (80A), et un matériau de support (84) fourni sur la surface de fond de l'élément piézoélectrique (82) ;
- une partie de logement pour oscillateur à ultrasons (96) fournie sur le corps de partie d'extrémité distale (70), couvrant les surfaces latérales et la surface de fond de l'oscillateur à ultrasons (80), et logeant l'oscillateur à ultrasons (80), et une lentille acoustique (90) couvrant la surface d'observation (80A) de l'oscillateur à ultrasons (80) et adhérent à la partie de logement pour oscillateur à ultrasons (96), dans lequel une entretoise (198) est fournie entre au moins une des surfaces latérales de l'oscillateur à ultrasons (80) et la partie de logement pour oscillateur à ultrasons (96), et dans lequel la lentille acoustique (90) couvre également l'entretoise (198),
- caractérisé en ce que** l'entretoise (198) présente une épaisseur uniforme dans une direction normale par rapport à une surface de l'entretoise, laquelle est en contact avec une surface correspondante des surfaces latérales (96B, 96C) de l'oscillateur à ultrasons (80) lorsque l'oscillateur à ultrasons est logé dans la partie de logement pour oscillateur à ultrasons (96), et l'entretoise (198) est élastique dans une direction d'épaisseur correspondant à la direction normale.
2. Endoscope à ultrasons (10) selon la revendication 1, dans lequel l'entretoise (198) est fournie entre la partie de logement pour oscillateur à ultrasons et une surface latérale parallèle à un axe longitudinal de l'unité d'introduction parmi les surfaces latérales de l'oscillateur à ultrasons.
  3. Endoscope à ultrasons (10) selon la revendication 2, dans lequel les entretoises sont fournies entre la partie de logement pour oscillateur à ultrasons et deux surfaces latérales parallèles à l'axe longitudinal de l'unité d'introduction et se faisant face parmi les surfaces latérales de l'oscillateur à ultrasons, et lorsque l'oscillateur à ultrasons (80) est logé dans la partie de logement pour oscillateur à ultrasons, les entretoises fournies entre la partie de logement pour oscillateur à ultrasons et les deux surfaces latérales présentent des épaisseurs égales entre elles, chaque épaisseur étant mesurée dans une direction normale à une surface de l'entretoise, laquelle est en contact avec une surface correspondante des surfaces latérales de l'oscillateur à ultrasons (80).
  4. Endoscope à ultrasons selon l'une quelconque des revendications 1 à 3, dans lequel l'entretoise est fournie entre la partie de logement pour oscillateur à ultrasons et une surface latérale croisant l'axe longitudinal de l'unité d'introduction parmi les surfaces latérales de l'oscillateur à ultrasons (80).
  5. Endoscope à ultrasons (10) selon la revendication 4, dans lequel les entretoises sont fournies entre la partie de logement pour oscillateur à ultrasons et deux surfaces latérales croisant l'axe longitudinal de l'unité d'introduction et se faisant face parmi les surfaces latérales de l'oscillateur à ultrasons, et lorsque l'oscillateur à ultrasons est logé dans la partie de logement pour oscillateur à ultrasons, les entretoises (198) fournies entre la partie de logement pour oscillateur à ultrasons et les deux surfaces latérales présentent des épaisseurs égales entre elles, chaque épaisseur étant mesurée dans une direction normale à une surface de l'entretoise, laquelle est en contact avec une surface correspondante des surfaces latérales de l'oscillateur à ultrasons.
  6. Endoscope à ultrasons selon l'une quelconque des revendications 1 à 5, dans lequel une entretoise supplémentaire (1110) est fournie entre la partie de logement pour oscillateur à ultrasons et la surface de fond de l'oscillateur à ultrasons (80).
  7. Endoscope à ultrasons selon la revendication 6, comprenant en outre une unité de connexion de câblage fournie sur l'oscillateur à ultrasons (80) et connectée avec un câblage pour fournir une tension d'alimentation à l'oscillateur à ultrasons (80), dans lequel l'unité de connexion de câblage est fournie dans une partie centrale de la surface de fond, et l'entretoise supplémentaire (1110) est fournie dans une partie périphérique de la surface de fond.
  8. Procédé de fabrication d'un endoscope à ultrasons (10) incluant une unité d'introduction (22) introduite à l'intérieur d'un corps, un corps de partie d'extrémité distale (70) fourni sur une extrémité distale de l'unité d'introduction (22) et doté d'une ouverture de guidage d'outil chirurgical (54), une unité d'observation à ultrasons (50) fournie sur le corps de partie d'extrémité distale (70), un oscillateur à ultrasons (80) fourni sur l'unité d'observation à ultrasons (50) et incluant une surface d'observation (80A) par le biais de laquelle des ondes ultrasonores sont communiquées, des surfaces latérales (80B-80E) adjacentes à la surface d'observation, une surface de fond face à la surface d'observation (80A), un élément piézoélectrique (82) fourni plus près de la surface d'observation, et un matériau de support (84) fourni sur la surface de fond de l'élément piézoélectrique (82), et une partie de logement pour oscillateur à ultrasons fournie sur le corps de partie d'extrémité distale et logeant l'oscillateur à ultrasons, le procédé comprenant les étapes consistant à :
    - loger l'oscillateur à ultrasons (80) dans la partie

de logement pour oscillateur à ultrasons (96), de telle sorte qu'une entretoise (198, 1110) est fournie entre au moins une des surfaces latérales (80B-80E) de l'oscillateur à ultrasons (80) et la partie de logement pour oscillateur à ultrasons (96), dans lequel l'entretoise présente une épaisseur uniforme dans une direction normale par rapport à une surface de l'entretoise, laquelle est en contact avec une surface correspondante des surfaces latérales de l'oscillateur à ultrasons (80) lorsque l'oscillateur à ultrasons est logé dans la partie de logement pour oscillateur à ultrasons (96), l'entretoise étant élastique dans une direction d'épaisseur correspondant à la direction normale ;

fixer temporairement l'oscillateur à ultrasons (80) sur la partie de logement pour oscillateur à ultrasons (96) tandis qu'une ligne étendue d'une ligne centrale de l'ouverture de guidage d'outil chirurgical est positionnée dans une région d'observation de l'oscillateur à ultrasons (80), et former une lentille acoustique (90) sur la surface d'observation de l'oscillateur à ultrasons (80) avec une résine fluide, et remplir un espace entre l'oscillateur à ultrasons et la partie de logement pour oscillateur à ultrasons avec la résine tout en fixant temporairement l'oscillateur à ultrasons (80).

5

10

15

20

25

30

35

40

45

50

55

FIG. 1

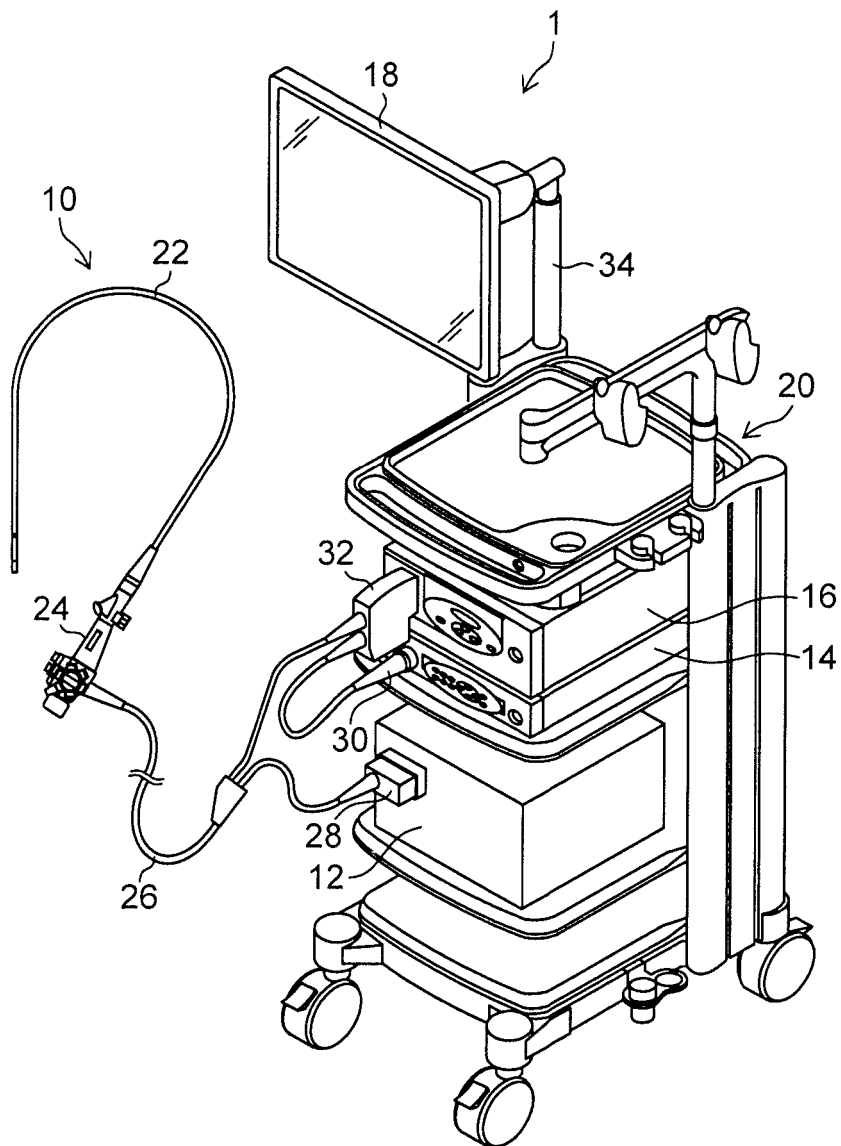

FIG.2

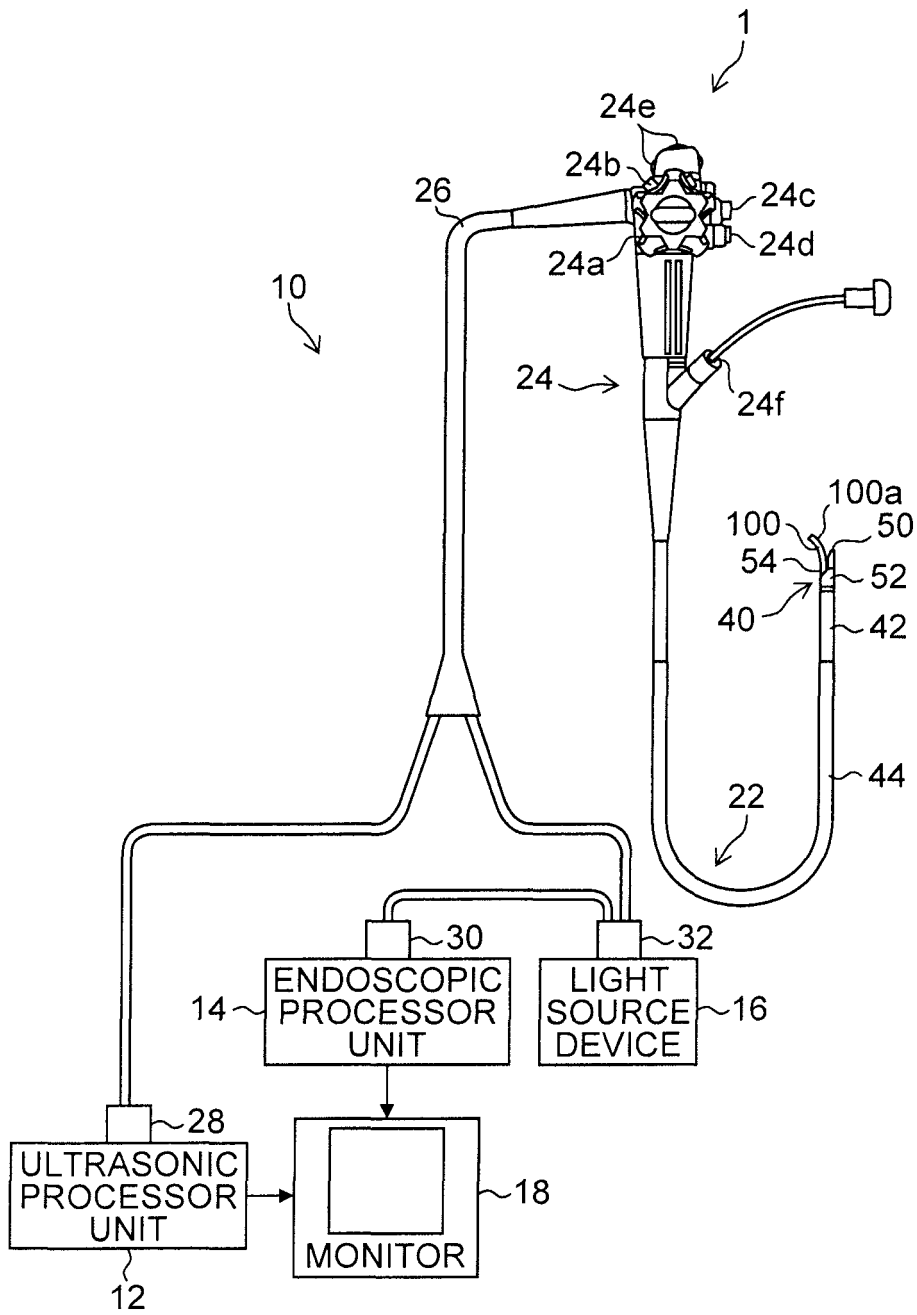

FIG.3

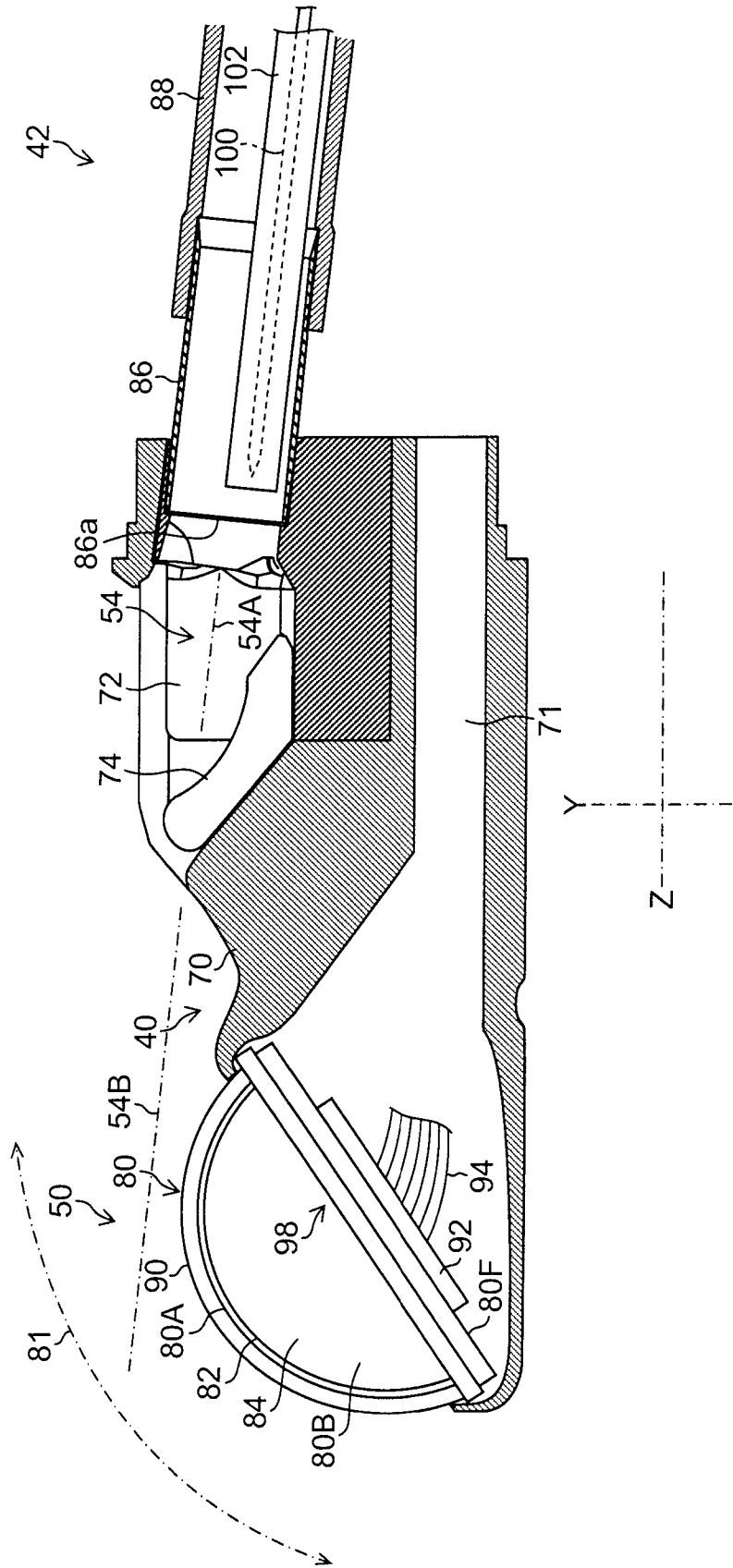

FIG.4

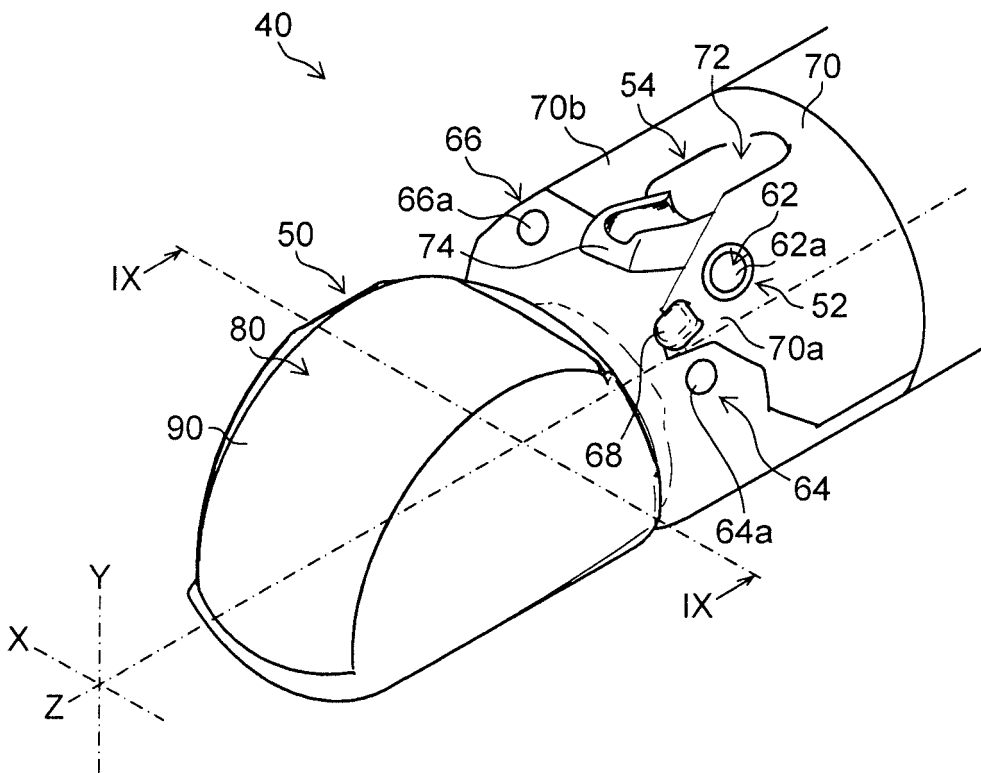

FIG.5

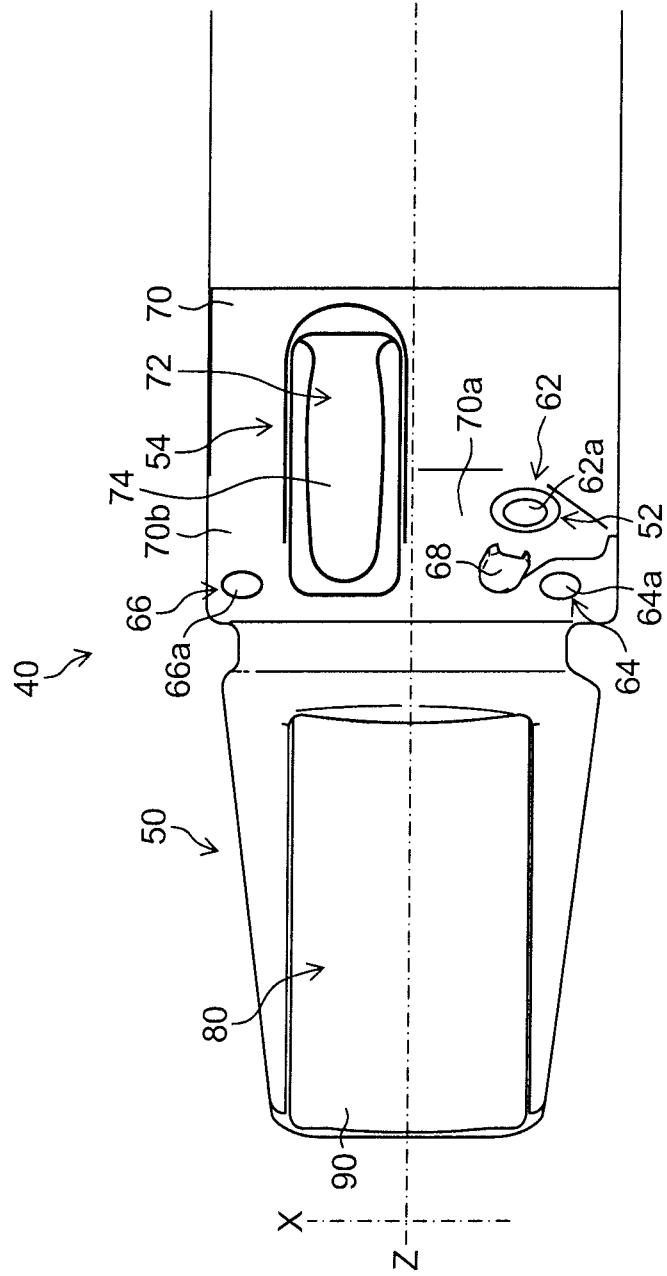

FIG.6

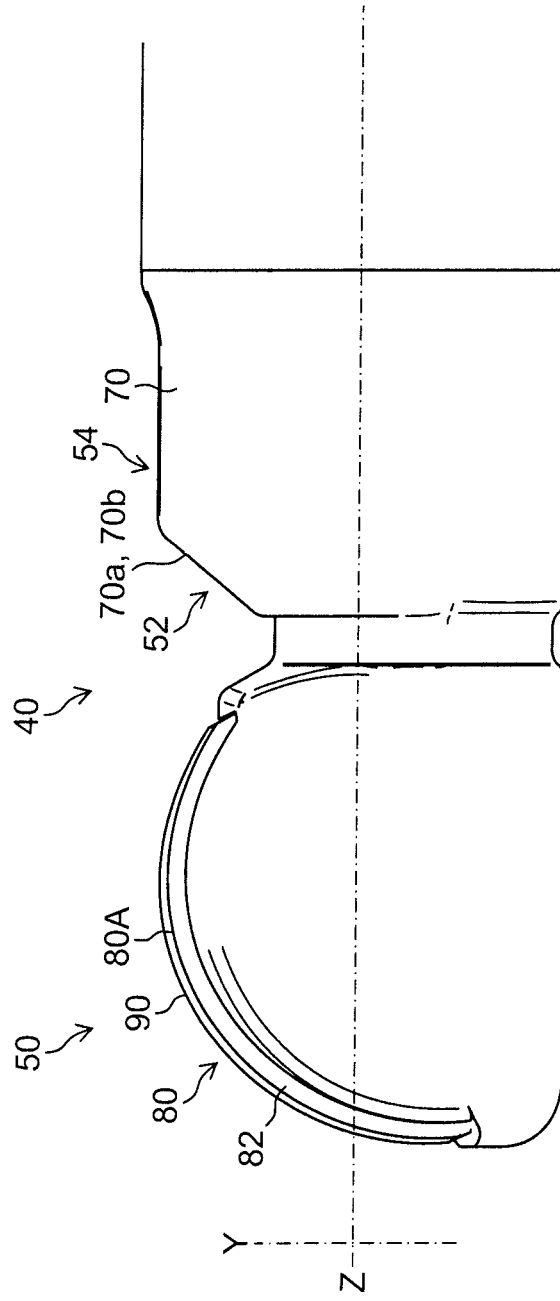

FIG.7

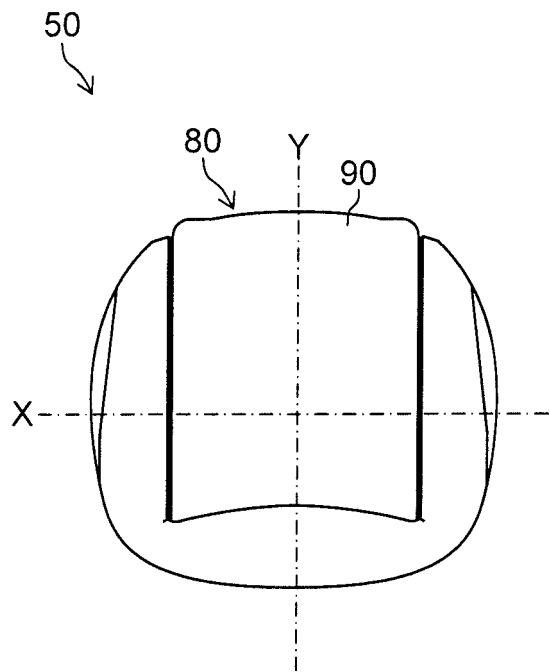



FIG.9

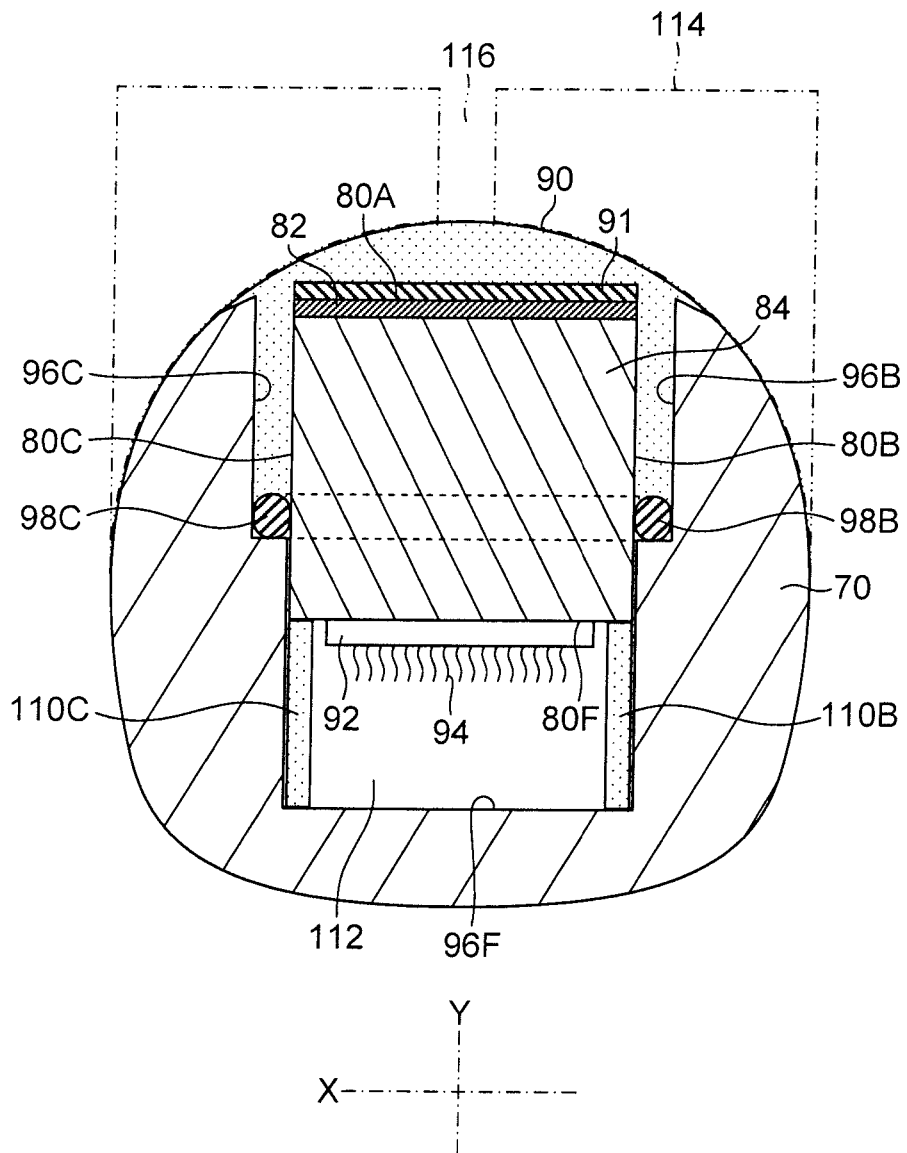

FIG.10

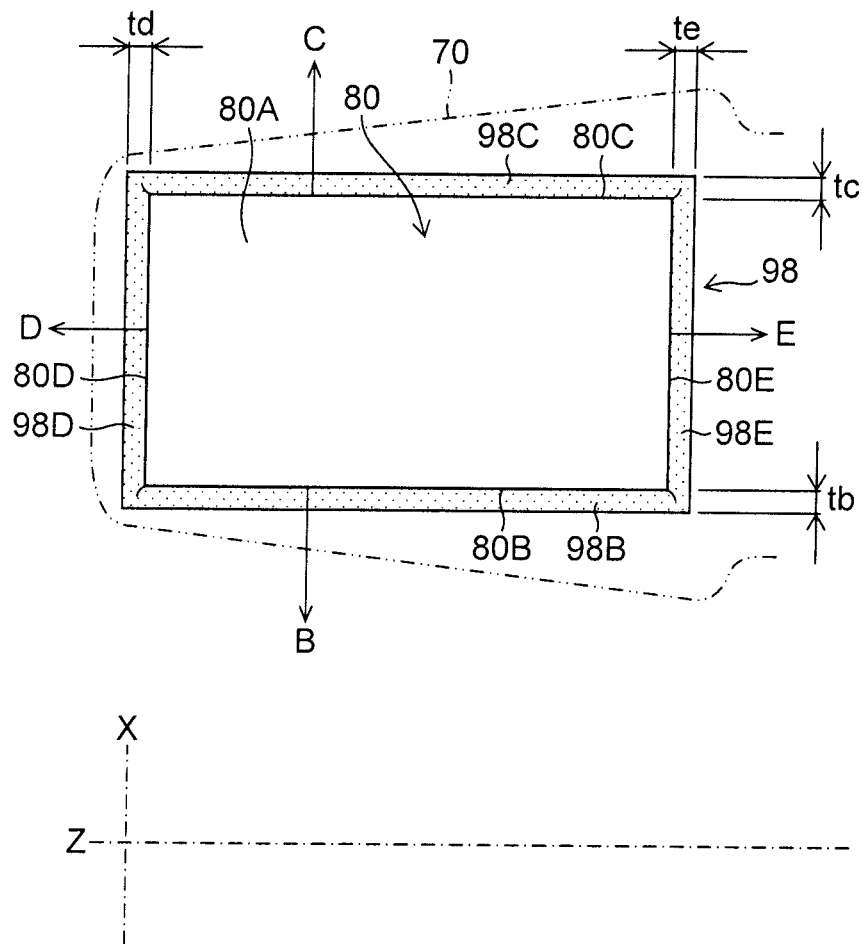

FIG.11

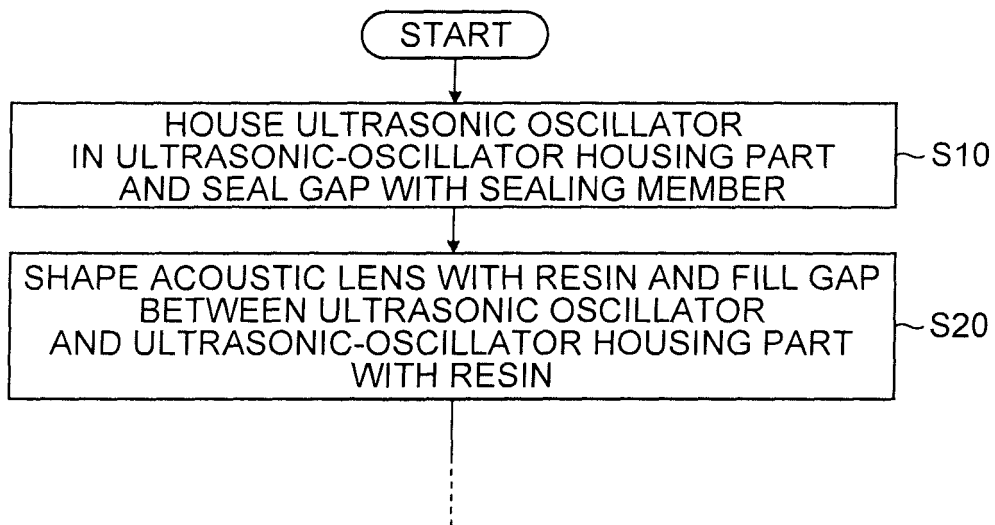

FIG. 12

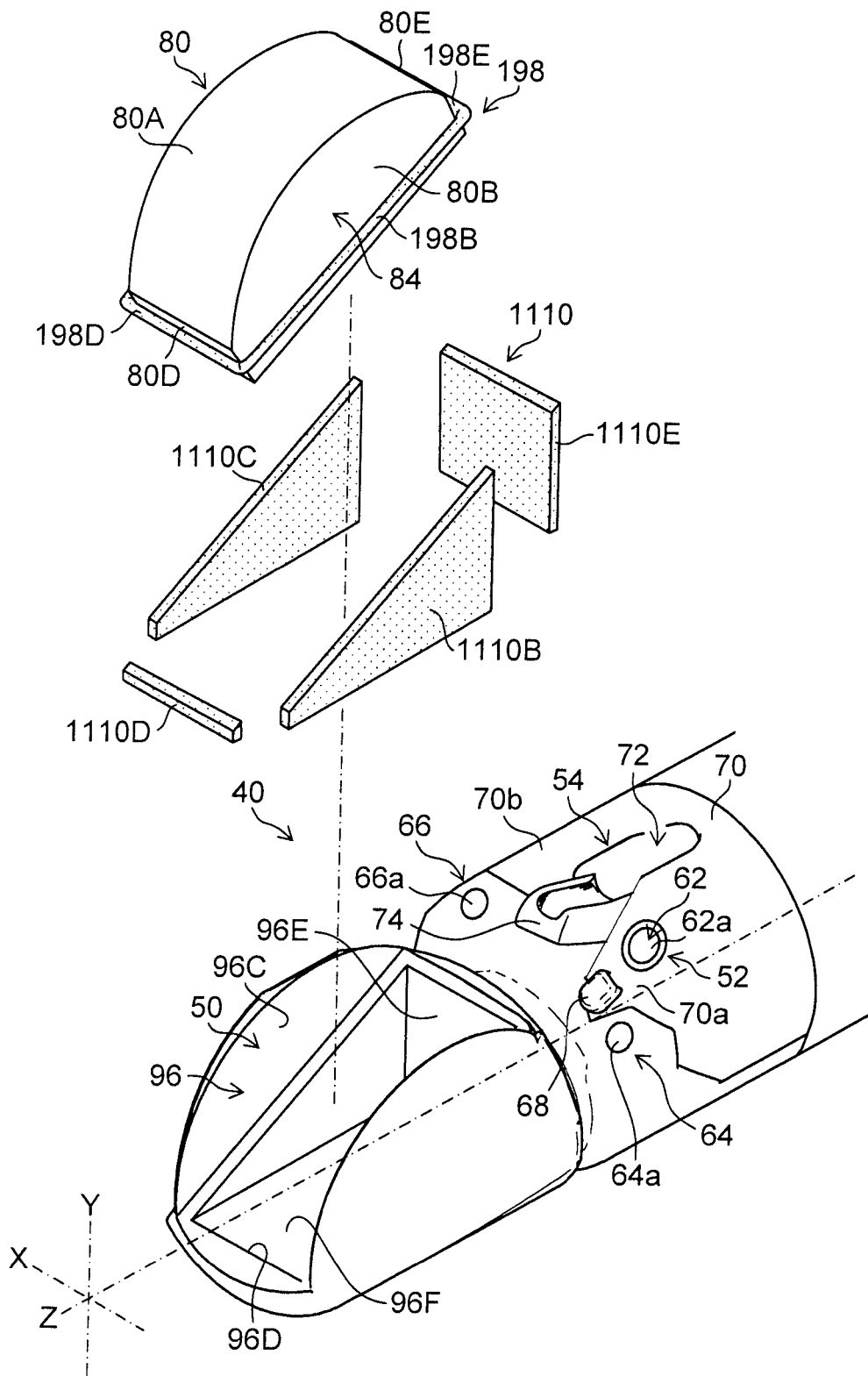

FIG.13

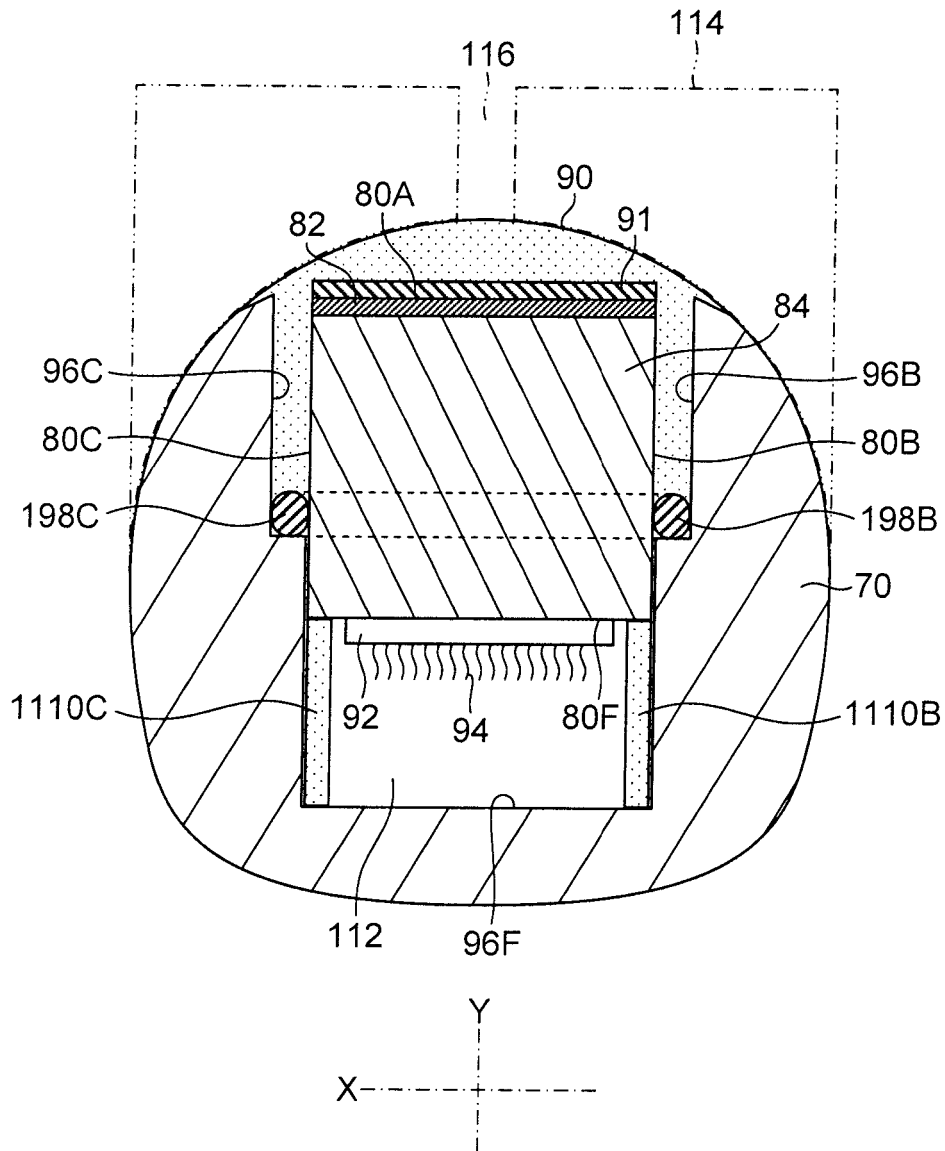

FIG.14

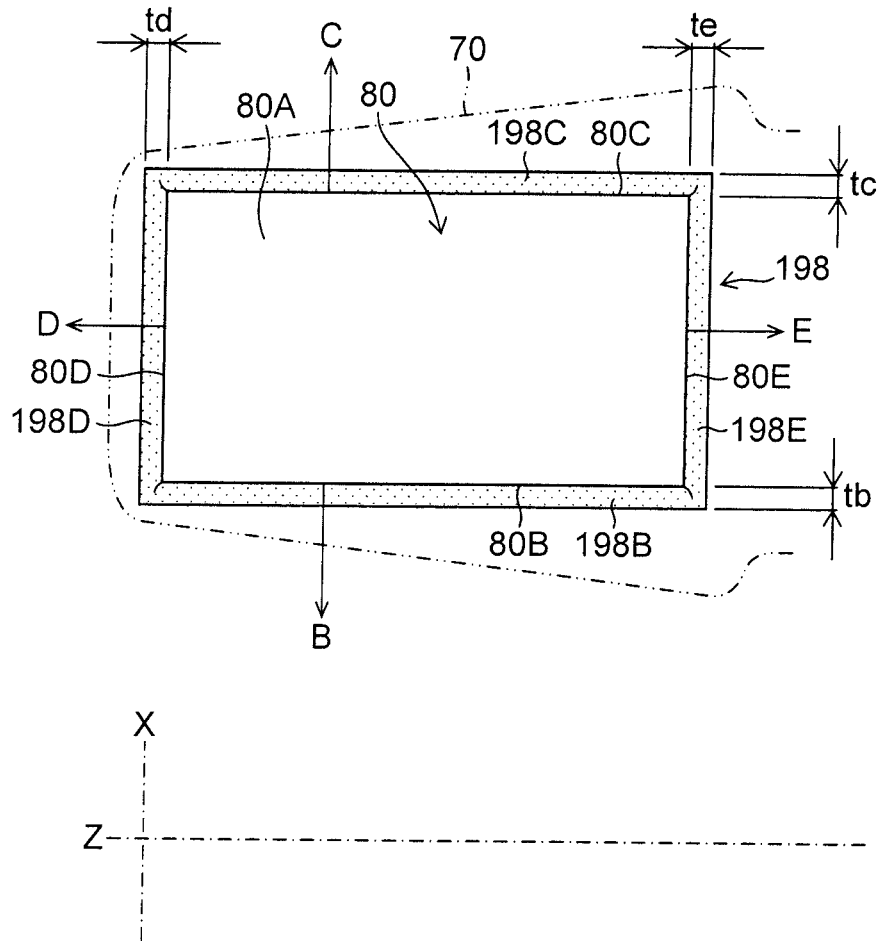

FIG.15

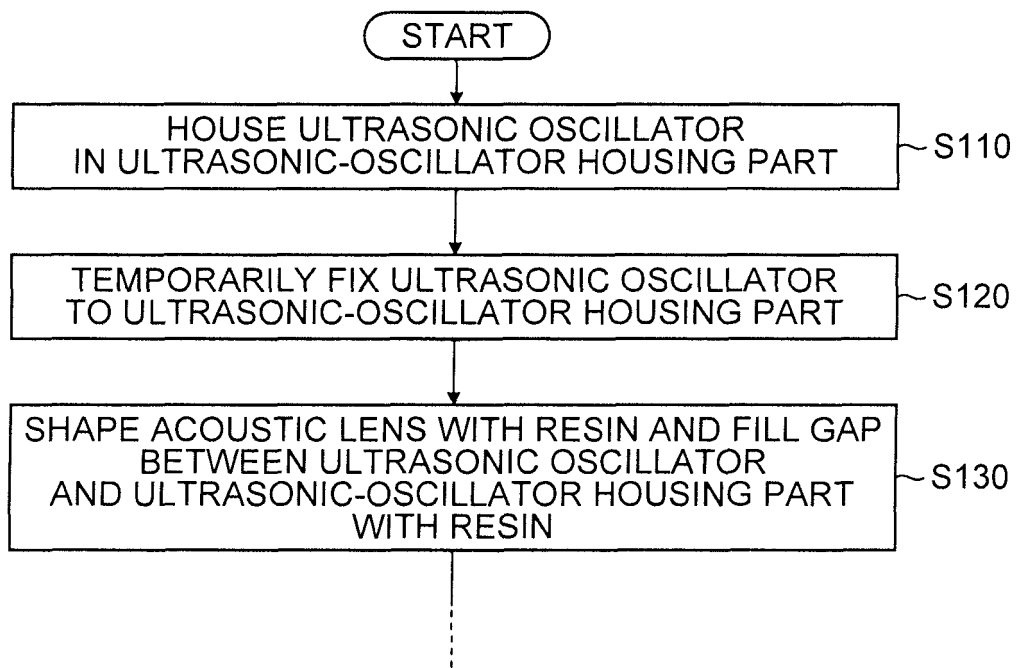

FIG.16

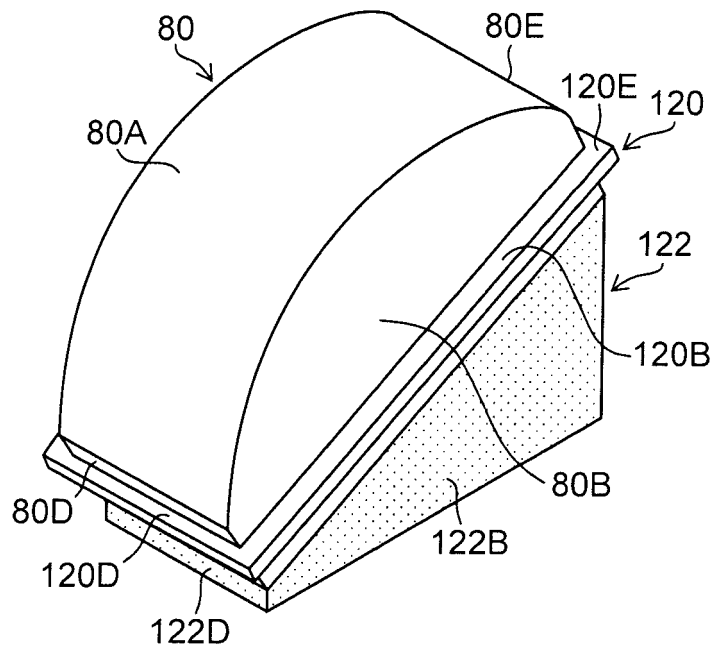

FIG. 17

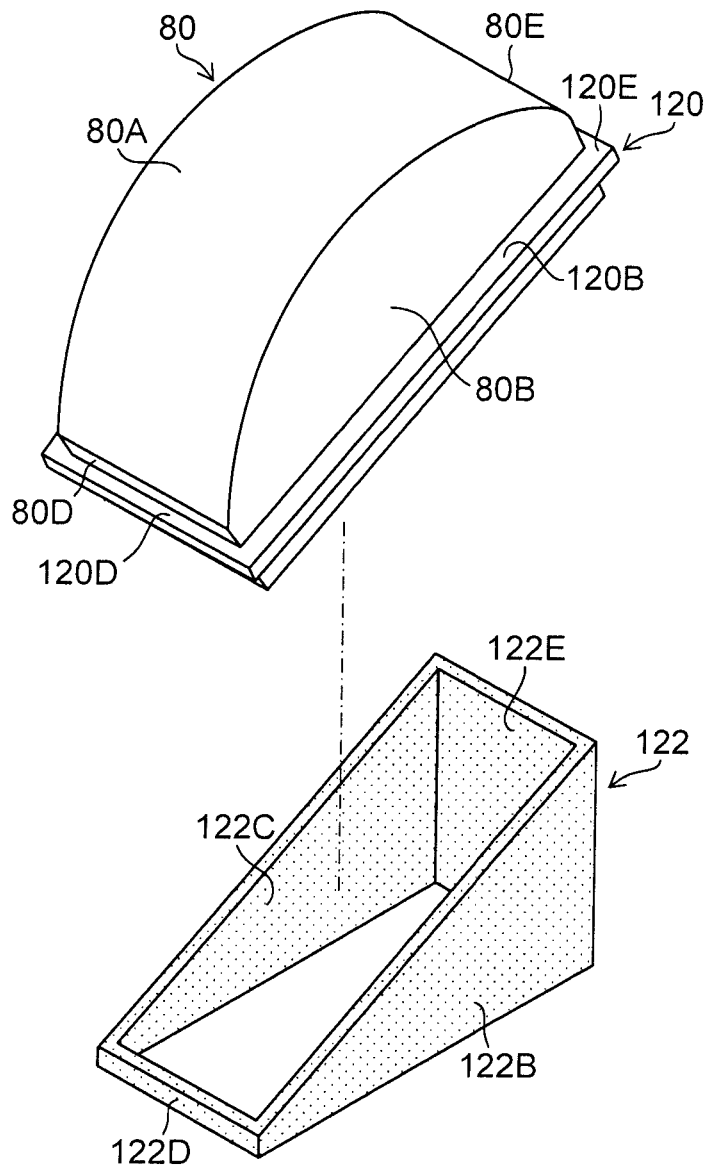
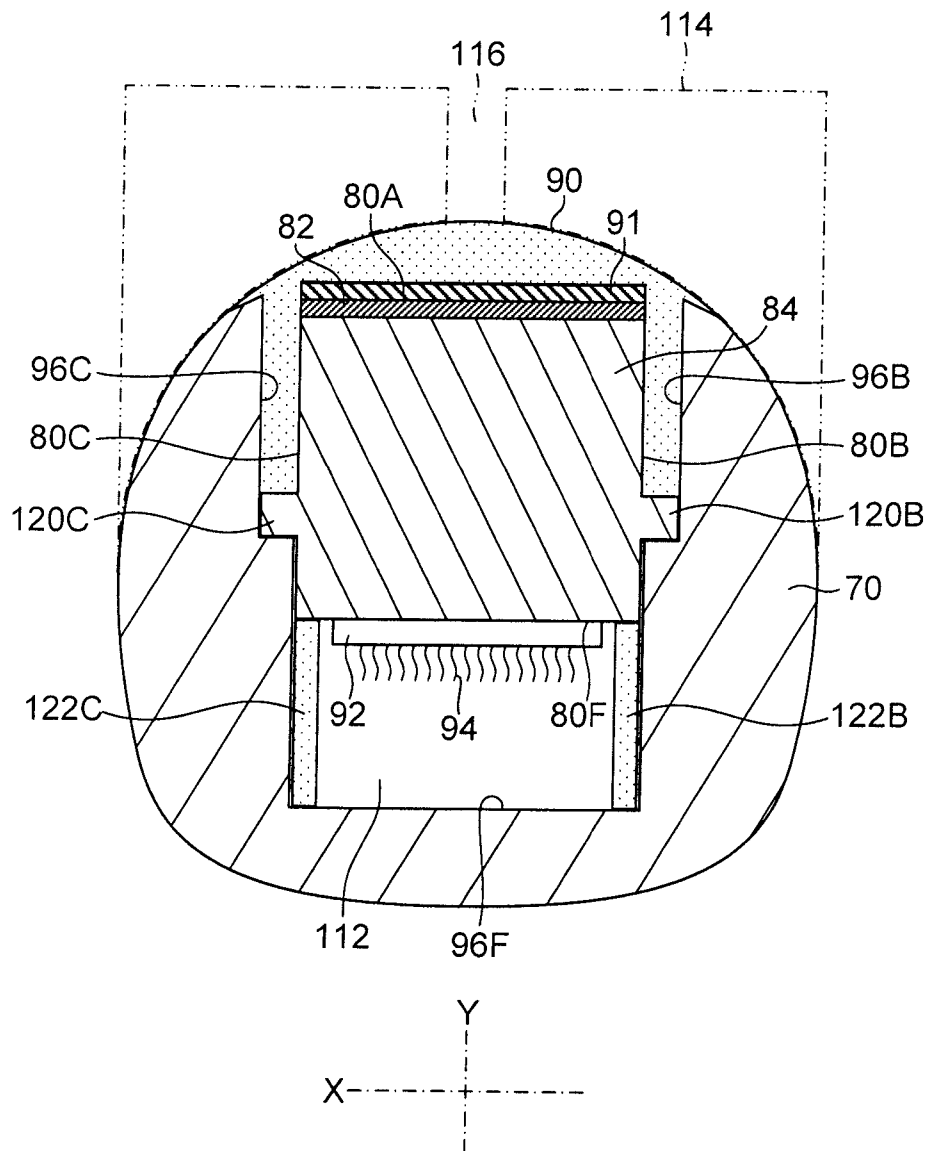

FIG.18



**REFERENCES CITED IN THE DESCRIPTION**

*This list of references cited by the applicant is for the reader's convenience only. It does not form part of the European patent document. Even though great care has been taken in compiling the references, errors or omissions cannot be excluded and the EPO disclaims all liability in this regard.*

**Patent documents cited in the description**

- JP 2013027695 A [0002] [0003] [0006] [0011] [0012]
- WO 2015053044 A1 [0005]
- JP 2002113005 A [0008] [0015] [0016] [0017]

专利名称(译)	超声波内窥镜及其制造方法		
公开(公告)号	<a href="#">EP3167811B1</a>	公开(公告)日	2019-03-13
申请号	EP2016197688	申请日	2016-11-07
[标]申请(专利权)人(译)	富士胶片株式会社		
申请(专利权)人(译)	富士胶片株式会社		
当前申请(专利权)人(译)	富士胶片株式会社		
[标]发明人	MORIMOTO YASUHIKO		
发明人	MORIMOTO, YASUHIKO		
IPC分类号	A61B8/12 A61B1/00 A61B1/018 A61B8/00		
CPC分类号	A61B8/12 A61B1/00091 A61B1/00096 A61B1/00098 A61B1/0011 A61B1/015 A61B1/018 A61B1/05 A61B1/07 A61B8/445		
优先权	2015219041 2015-11-09 JP 2015220042 2015-11-10 JP		
其他公开文献	EP3167811A1		
外部链接	<a href="#">Espacenet</a>		

摘要(译)

本发明提供一种超声波内窥镜，其中配线可以可靠地固定到超声波振荡器容纳部的配线容纳空间，以及超声波内窥镜的制造方法。根据本发明，通过用密封构件98和110密封在超声波振荡器80和超声波振荡器壳体部分96之间形成的间隙，从外部封装电线容纳空间112。利用这种配置，电线容纳空间112用于将导线94固定在导线容纳空间112中的填充剂可以充分填充。这实现了超声波内窥镜10，其中导线94可以可靠地固定到超声波振荡器壳体部分96的导线容纳空间112。

FIG. 1

