

(19)



(11)

**EP 2 698 113 A2**

(12)

**EUROPEAN PATENT APPLICATION**  
published in accordance with Art. 153(4) EPC

(43) Date of publication:

**19.02.2014 Bulletin 2014/08**

(51) Int Cl.:

**A61B 8/00 (2006.01) G01N 29/24 (2006.01)**

(21) Application number: **12770545.7**

(86) International application number:

**PCT/KR2012/002800**

(22) Date of filing: **13.04.2012**

(87) International publication number:

**WO 2012/141519 (18.10.2012 Gazette 2012/42)**

(84) Designated Contracting States:

**AL AT BE BG CH CY CZ DE DK EE ES FI FR GB  
GR HR HU IE IS IT LI LT LU LV MC MK MT NL NO  
PL PT RO RS SE SI SK SM TR**

- **CHO, Seongtaek  
Seoul 138-931 (KR)**
- **RHO, Sebeom  
Seoul 134-022 (KR)**

(30) Priority: **15.04.2011 KR 20110035207**

(74) Representative: **Thorniley, Peter et al  
Kilburn & Strode LLP  
20 Red Lion Street  
London WC1R 4PJ (GB)**

(71) Applicant: **Alpinion Medical Systems Co., Ltd.  
Hwaseong-si, Gyeonggi-do 445-380 (KR)**

(72) Inventors:

- **LEE, Daehyun  
Seoul 138-891 (KR)**

(54) **APPARATUS FOR DIAGNOSING ULTRASOUND IMAGE AND METHOD FOR DIAGNOSING SAME**

(57) An ultrasonic image apparatus and a method therefor are disclosed. The ultrasound diagnostic imaging apparatus comprises a pulse generator, transducer, multiplexer (MUX) and dummy MUX. The pulse generator is configured to generate a pulse of an electric signal. The transducer is configured to convert the pulse of the electric signal generated by the pulse generator into an ultrasonic wave signal and transmit the ultrasonic wave signal to an object. The MUX is configured to select one or more channels corresponding to at least one element

of the transducer, and to perform a switching operation between different applied voltages. The dummy MUX is configured to apply, to an output end of the MUX, a reverse signal of an output signal of the MUX by performing an inverse switching operation which is opposite to the switching operation by the MUX when the MUX performs the switching operation between the different applied voltages.

**EP 2 698 113 A2**

**Description**

[Technical Field]

5 **[0001]** The present disclosure in some embodiments relates to an ultrasonic diagnostic apparatus and an ultrasonic diagnostic method therefor. More particularly, the present disclosure relates to an ultrasound diagnostic imaging apparatus for improving the picture quality of an ultrasonic image effectively by removing spike voltages generated by switching operations between a first and a second applied voltage to a high voltage multiplexer (HVMUX), and an ultrasound diagnostic imaging method therefor.

10 [Background]

**[0002]** The statements in this section merely provide background information related to the present disclosure and may not constitute prior art.

15 **[0003]** Rapid developments of the electronics, signal processing and especially, digital signal processing technology have made a significant impact on the field of diagnostic imaging. Diagnostic imaging system, which can see through the internal organs of the human body without incision of the body, is considered the center of medical diagnostic apparatus and instruments. The diagnostic imaging systems in current use include an X-ray diagnostic apparatus, a Magnetic Resonance Imaging (MRI) diagnostic apparatus, an ultrasound diagnostic apparatus and the like, and each has its own merit and demerit. The ultrasound diagnostic imaging apparatus has advantages of a real time diagnosis and better affordability at the price of reduced resolution. As a result, the ultrasound diagnostic imaging apparatus has become one of the essential medical equipment in virtually all the medical areas such as internal medicine, obstetrics and gynecology, pediatrics, urology, ophthalmology, radiology and the like.

20 **[0004]** The ultrasound wave for the ultrasound diagnostic imaging apparatus uses frequencies ranging from several MHz to tens of MHz. As the ultrasound wave passes through the human body, its speed and the degree of attenuation vary according to a medium. An ultrasound image is basically formed from reflected waves generated by a boundary between different media.

25 **[0005]** When a speed of the ultrasound passing through the human body is  $V$ , a density of the medium is  $\rho$ , and a volume modulus is  $B$ ,  $V$  can be given by Equation 1.

$$V = \sqrt{\frac{B}{\rho}}$$

Equation 1

40 **[0006]** The speed of the ultrasound wave within the human body varies depending on medium. Researches have been conducted on compensation for variations of the speed of ultrasound wave within the human body.

45 **[0007]** An important physical property of the ultrasound wave is an attenuation while it is propagated within a medium. Intensity  $I$  of the ultrasound wave according to propagation distance  $z$  is expressed by Equation 2.

$$I = I_0 \exp(-2\alpha z)$$

Equation 2

55 **[0008]** In equation 2,  $\alpha$  denotes an attenuation coefficient. The attenuation coefficient is closely related to frequency of the ultrasound wave. The attenuation coefficient increases nearly linearly in proportion to frequency in a frequency band used for the ultrasound diagnostic imaging apparatus.

**[0009]** Another important property of the ultrasound diagnostic imaging apparatus is a reflection. The reflection relates

to a characteristic impedance  $Z$  of the medium. Characteristic impedance  $Z$  of the medium is expressed by a product of material density  $\rho$  and ultrasound speed  $V$  as shown in Equation 3.

$$Z = \rho V$$

Equation 3

**[0010]** When the ultrasound is incident to a material having characteristic impedance  $Z_2$  from a material having characteristic impedance  $Z_1$ , reflectivity  $R$  is expressed by Equation 4.

$$R = \frac{Z_2 - Z_1}{Z_2 + Z_1}$$

Equation 4

**[0011]** FIG. 1 is a diagram for illustrating a basic principle of an ultrasound diagnostic imaging apparatus. A transducer 110 converts a pulse of an electrical signal generated by a pulse generator 120 into an ultrasound signal and transmits the ultrasound signal to an object. The transducer 110 converts the ultrasound signal reflected and returned from an interface between different media to the corresponding electrical signal and transmits the same to a signal processor 130. The signal processor 130 performs signal processings for the signal received from the transducer 110, such as a time gain compensation (TGC) amplification, a Rx beamforming, an echo processing, a spectral doppler processor (SDP)/color doppler processor (CDP), a digital scan converter (DSC) and the like, and then the processed signal is displayed as an image on a display 140.

**[0012]** Meanwhile, the number of channels through which the pulse generator 120 sends pulses, affects the quality of the ultrasound image such as focusing of an aperture. Taking this in consideration and in order to offer more elements, a TI (transducer interface) board of the ultrasound diagnostic imaging apparatus expands the number of channels toward more elements by using the HVMUX (high voltage multiplexer).

**[0013]** As illustrated in FIG. 2, one channel of the HVMUX is supplied with powers from a first power source  $V_{PP}$  and a second power source  $V_{NN}$ . An electrical signal is output to an output terminal  $V_{OUT}$  as a result of a first switching operation 210 of selecting the first power source  $V_{PP}$  or the second power source  $V_{NN}$  and a second switching operation 220 for determining whether to select a channel.

**[0014]** However, with a typical HVMUX, a spike voltage or a surge voltage as illustrated in FIG. 2 can be generated at the output terminal  $V_{OUT}$  by the influence of the bias voltage  $V_{PP}$  or  $V_{NN}$  simultaneously of the first switching operation 210, which causes to present an unwanted extra stray echo signal in the ultrasound image, in addition to the echo signal of the pulse duly generated by the pulse generator 120.

[Disclosure]

[Technical Problem]

**[0015]** The embodiments of the present disclosure provide an ultrasound diagnostic imaging apparatus for effectively improving the picture quality of an ultrasonic image by removing spike voltages generated by switching operations between a first and a second applied voltages to a high voltage multiplexer (HVMUX), and an ultrasound diagnostic imaging method therefor.

[Summary]

**[0016]** An aspect of the present disclosure provides an ultrasound diagnostic imaging apparatus, comprising: a pulse generator, a transducer, a multiplexer (MUX) and a dummy MUX. The pulse generator is configured to generate a pulse of an electric signal. The transducer is configured to convert the pulse of the electric signal generated by the pulse generator into an ultrasonic wave signal and to transmit the ultrasonic wave signal to an object. The multiplexer (MUX)

is configured to select one or more channels corresponding to at least one element of the transducer and to perform a switching operation between different applied voltages. And the dummy MUX is configured to apply, to an output end of the MUX, a reverse signal of an output signal of the MUX by performing an inverse switching operation which is opposite to the switching operation by the MUX, when the MUX performs the switching operation between the different applied voltages.

**[0017]** The dummy MUX blocks the reverse signal applied to the output end of the MUX upon completion of the switching operation between the different applied voltages.

**[0018]** In addition, the MUX may perform the switching operation between applied voltages of +100 V and -100 V.

**[0019]** The dummy MUX may perform the inverse switching operation from -100 V to +100 V when the switching operation is performed from +100 V to -100 V for the selected channel.

**[0020]** In addition, the dummy MUX may perform the inverse switching operation from +100 V to -100 V when the switching operation is performed from -100 V to +100 V for the selected channel.

**[0021]** Another aspect of the present disclosure provides an ultrasound diagnostic imaging apparatus, comprising: a pulse generator, a transducer, a multiplexer (MUX) and a reverse voltage application unit. The pulse generator is configured to generate a pulse of an electric signal. The transducer is configured to convert the pulse of the electric signal generated by the pulse generator into an ultrasonic wave signal and to transmit the ultrasonic wave signal to an object. The multiplexer (MUX) is configured to select one or more channels corresponding to at least one element of the transducer and to perform a switching operation between different applied voltages. And the reverse voltage application unit is configured to apply, to an output end of the selected channel, a reverse voltage of a spike voltage from resulting the switching operation, when the MUX performs the switching operation.

**[0022]** The reverse voltage application unit applies the reverse voltage simultaneously of the switching operation by the MUX and blocks the application of the reverse voltage upon completion of the switching operation by the MUX from one voltage to another voltage.

**[0023]** In addition, the MUX may perform a switching operation between applied voltages of +100 V and -100 V.

**[0024]** The reverse voltage application unit may be responsive to the switching operation of the MUX from +100 V to -100 V for applying, to the output end of the selected channel, a spike voltage generated from an inverse switching operation from -100 V to +100 V.

**[0025]** In addition, the reverse voltage application unit may be responsive to the switching operation of the MUX from -100 V to +100 V for applying, to the output end of the selected channel, a spike voltage generated from an inverse switching operation from +100 V to -100 V.

**[0026]** Yet another aspect of the present disclosure provides an ultrasound diagnostic imaging method, comprising: generating a pulse of an electric signal; performing, by a multiplexer (MUX), a selection of one or more channels corresponding to at least one element of the transducer and a switching operation between different applied voltages; applying, to an output end of the MUX, a reverse signal of an output signal of the MUX by performing an inverse switching operation which is opposite to the switching operation by the MUX; and converting the pulse of the electric signal outputted through the selected channel into an ultrasonic wave signal and transmitting the ultrasonic wave signal to an object.

**[0027]** The applying of the reverse signal comprises blocking the application of the reverse signal to the output end of the MUX upon completion of the switching operation between the different applied voltages.

**[0028]** In addition, the performing of the channel selection and the switching operation may comprise performing the switching operation between applied voltages of +100 V and -100 V.

**[0029]** In addition, the applying of the reverse signal may comprise performing a voltage application by an inverse switching operation from -100 V to +100 V when the switching operation is performed for the selected channel from +100 V to -100 V.

**[0030]** In addition, the applying of the reverse signal may comprise performing a voltage application by an inverse switching operation from +100 V to -100 V when the switching operation is performed for the selected channel from -100 V to +100 V.

**[0031]** Yet another aspect of the present disclosure provides an ultrasound diagnostic imaging method, comprising: generating a pulse of an electric signal; performing, by a multiplexer (MUX), a selection of one or more channels corresponding to at least one element of the transducer and a switching operation between different applied voltages; applying, to an output end of the selected channel, a reverse voltage of a spike voltage resulting from the switching operation of the MUX; and converting the pulse of the electric signal outputted through the selected channel into an ultrasonic wave signal and transmitting the ultrasonic wave signal to an object.

**[0032]** The applying of the reverse voltage with respect to the spike voltage comprises applying the reverse voltage simultaneously of the switching operation of the MUX and blocking the application of the reverse voltage upon completion of the switching operation.

**[0033]** In addition, the performing of the switching operation may comprise performing the switching operation between applied voltages of +100 V and -100 V.

**[0034]** The applying of the reverse voltage may comprise applying the spike voltage by an inverse switching operation

from -100 V to +100 V when the switching operation of the MUX is performed from +100 to -100.

**[0035]** In addition, the applying of the reverse voltage with respect to the spike voltage may comprise applying the spike voltage by an switching operation from +100 V to -100 V when the switching operation of the MUX is performed from -100 to +100.

[Advantageous Effects]

**[0036]** According to some embodiments of the present disclosure, an ultrasonic image can be improved in picture quality by removing spike voltages generated by switching operations between a first and a second applied voltage to a HVMUX.

[Description of Drawings]

**[0037]**

FIG. 1 is a diagram for illustrating the basic principle of an ultrasound diagnostic imaging apparatus.

FIG. 2 is an exemplary diagram of spike voltages generated in a HVMUX.

FIG. 3 is a schematic diagram of an ultrasound diagnostic imaging apparatus according to at least one embodiment.

FIG. 4 is an exemplary diagram of a pulse generated by a pulse generator in FIG. 3.

FIG. 5 is an exemplary diagram of a MUX and a dummy MUX used in the ultrasound diagnostic imaging apparatus of FIG. 3.

FIG. 6 is a schematic diagram of an ultrasound diagnostic imaging apparatus according to another embodiment.

FIG. 7 is a flowchart of an ultrasound diagnostic imaging method according to at least one embodiment.

FIG. 8 is a flowchart of an ultrasound diagnostic imaging method according to another embodiment.

[Detailed Description]

**[0038]** Hereinafter, some embodiments of the present disclosure will be described in detail with reference to the accompanying drawings. In the following description, like reference numerals designate like elements although the elements are shown in different drawings. Further, in the following description of the embodiments, a detailed description of known functions and configurations incorporated herein will be omitted for the purpose of clarity and for brevity.

**[0039]** Additionally, in describing the components of the present disclosure, terms like first, second, A, B, (a), and (b) are used. These are solely for the purpose of differentiating one component from another, and one of ordinary skill would understand the terms are not to imply or suggest the substances, order or sequence of the components. If a component is described as 'connected', 'coupled', or 'linked' to another component, one of ordinary skill in the art would understand the components are not necessarily directly 'connected', 'coupled', or 'linked' but also are indirectly 'connected', 'coupled', or 'linked' via a third component.

**[0040]** FIG. 3 is an exemplary schematic diagram of an ultrasound diagnostic imaging apparatus according to at least one embodiment of the present disclosure.

**[0041]** Referring to FIG. 3, an ultrasound diagnostic imaging apparatus 300 according to an embodiment of the present disclosure may include a pulse generator 310, a transducer 320, a MUX 330, and a dummy MUX 340.

**[0042]** The pulse generator 310 generates a pulse of an electrical signal. The pulse generator 310 excites the transducer 320 with pulse width  $T_p$  scaled down as illustrated in FIG. 4 for increasing the axial resolution of the pulse and with pulse size  $V$  sufficiently enlarged for increasing the signal/noise (S/N) ratio.

**[0043]** The transducer 320 converts the electrical signal pulse generated by the pulse generator 310 to an ultrasound signal and transmits the ultrasound signal to an object, and converts the ultrasound signal reflected and returned from an interface between different media of the object to an electrical signal and transmits the electrical signal to a signal processor (not shown). Although the instant embodiment also involves the signal processor for processing signals by, for example, the time gain compensation (TGC) amplification, Rx beamforming, echo processing, spectral doppler processor (SDP)/color doppler processor (CDP) or digital scan converter (DSC) and involves displaying images on the display, descriptions of the signal processor and the display will be hereinafter omitted to focus on the subject matter of the present disclosure.

**[0044]** When an ultrasound signal is shot to the object by the transducer 320, if an interface between materials of different acoustic impedances exists in the propagation medium, a reflection occurs at the interface and a part of the ultrasound signal passes through the interface. When there is a plurality of interfaces, the ultrasonic echo signals are sequentially reflected and returned. In this event, the returned echo applies a stress to the piezoelectric porcelain of the transducer 320, generates an electric field in proportion to the intensity of the echo, and converts the electric field to an electrical signal. One ultrasound pulse transmitted to the object generates a pulse echo from each of the points of various

depths (interfaces) within the object, and the echo from a tissue at distance  $x$  occurs on a time axis at  $t=2x/c$  ( $c=1530$  m/s: average sonic speed) in consideration of a pulse reciprocating propagation distance. Accordingly, the reflection position can be determined back from the delay time of the transmitted pulse.

**[0045]** In general, a probe is formed by combining a plurality of elements of the transducer 320, where the MUX 330 selects channels corresponding to the elements of the transducer 320. In this event, different bias voltages are applied to the MUX 330, and the MUX 330 performs a switching operation between the applied different bias voltages and enables the pulse of the electrical signal generated by the pulse generator 310 to be transmitted through the selected channel.

**[0046]** In the switching operation between the different voltages applied to the MUX 330, the dummy MUX 340 applies a reverse signal of the output signal of the MUX 330 to an output terminal of the MUX 330 by performing the inverse switching operation which is opposite to the switching operation of the MUX 330. In order to implement such an operation, the dummy MUX 340 may be configured as illustrated in FIG. 5. Two different voltages  $V_{PP}$  and  $V_{NN}$  may be applied to one channel selected by the MUX 330 with switching operations performed between  $V_{PP}$  and  $V_{NN}$ . Then, the dummy MUX 340 may have the same configuration as that of the MUX 330 and apply the reverse signal of the output signal of the MUX 330 to the output terminal of the MUX 330 by the switching operation opposite to the switching operation of the MUX 330. For example, the MUX 330 and dummy MUX 340 can be implemented so that the MUX 330 performs the switching operation from applied voltage  $V_{PP}$  to applied voltage  $V_{NN}$ , and in response, the dummy MUX 340 performs the opposite switching operation from  $V_{NN}$  to  $V_{PP}$  and that an output signal of the dummy MUX 340 is combined with the output signal of the MUX 330. Similarly, when the MUX 330 performs the switching operation from applied voltage  $V_{NN}$  to applied voltage  $V_{PP}$ , the dummy MUX 340 performs the opposite switching operation from  $V_{PP}$  to  $V_{NN}$ , and the output signal of the dummy MUX 340 may be combined with the output signal of the MUX 330. The MUX 330 may have applied voltages of +100 V and -100 V. When the MUX 330 makes the voltage switching from +100 V to -100 V, the dummy MUX 340 performs switching from -100 V to +100 V, and the output signal of the MUX 330 may combine with the output signal of the dummy MUX 340. Likewise, when the MUX 330 performs the voltage switching from -100 V to +100 V, the dummy MUX 340 performs the switching from +100 V to -100 V and the output signal of the MUX 330 may combine with the output signal of the dummy MUX 340. The applied voltages described herein are only an example, and the switching operations can be performed between various applied voltages.

**[0047]** Meanwhile, the dummy MUX 340 blocks the application of the reverse signal to the output terminal of the MUX 330 upon completing the switching operations of the MUX 330 between the different voltages. This is to block only spike voltages generated in the voltage switching operations of the MUX 330 and to prevent influence by the voltages applied to the dummy MUX 340 after the voltage switching operations of the MUX 330.

**[0048]** FIG. 6 is a schematic diagram of an ultrasound diagnostic imaging apparatus according to another embodiment of the present disclosure.

**[0049]** Referring to FIG. 6, an ultrasound diagnostic imaging apparatus 600 according to an embodiment of the present disclosure may include a pulse generator 610, a MUX 620, a transducer 630, and a reverse voltage application unit 640. Here, detailed descriptions of the pulse generator 610, the MUX 620 and the transducer 630 will be omitted herein since their configurations and operations are the same as those of the pulse generator 310, the MUX 320 and the transducer 330.

**[0050]** When the switching operation is performed by the MUX 630, the inverse voltage application unit 640 applies a reverse voltage of the spike voltage by the switching operation of the MUX 630 to an output terminal of the selected channel. In this event, the reverse voltage application unit 640 may empirically acquire the spike voltage generated from the switching operation of the MUX 630, and an average value of the empirically acquired spike voltages or a maximum value and a minimum value of the empirically acquired spike voltages are stored.

**[0051]** In response to the switching operation between the different voltages applied to the MUX 630, the reverse voltage application unit 640 forms a virtual spike voltage based on the average value of the empirically acquired spike voltages or the maximum value and the minimum value of the empirically acquired spike voltages, and reverses and then applies the formed spike voltage to the output terminal of the MUX 630.

**[0052]** The reverse signal application unit 640 applies the reverse voltage of the spike voltage simultaneously of the switching operation of the MUX 630, blocking the application of the reverse voltage upon completion of the switching operation from one voltage to another voltage. This blocks or minimizes only the spike voltage generated from the voltage switching operation of the MUX 630 and saves the MUX 630 after its voltage switching operations from being influenced by the reverse voltage applied by the reverse voltage application unit 640.

**[0053]** FIG. 7 is a flowchart illustrating an example of an ultrasound diagnostic imaging method according to at least one embodiment of the present disclosure.

**[0054]** Referring to FIGs. 3 and 7, the pulse generator 310 generates a pulse of an electrical signal in step S710. The pulse generator 310 excites the transducer 320 with pulse width  $T_p$  scaled down as illustrated in FIG. 4 for increasing the axial resolution of the pulse and with pulse size  $V$  sufficiently enlarged for increasing the signal/noise (S/N) ratio.

**[0055]** The MUX 330 performs a switching operation between different applied voltages thereto and enables the pulse of the electrical signal generated by the pulse generator 310 to be transmitted through a selected channel in step S720.

**[0056]** The dummy MUX 340 has the same configuration as that of the MUX 330 and is responsive to the switching operation between the voltages to the MUX 330 for performing an opposite switching operation to the switching operation of the MUX 330 to apply a reverse signal of an output signal of the MUX 330 to an output terminal of the MUX 330 in step S730. For example, when the MUX 330 makes the voltage switching from +100 V to -100 V, the dummy MUX 340 performs switching from -100 V to +100 V, and the output signal of the MUX 330 may combine with the output signal of the dummy MUX 340. Similarly, when the MUX 330 performs the voltage switching from -100 V to +100 V, the dummy MUX 340 performs switching from +100 V to -100 V and the output signal of the MUX 330 may combine with the output signal of the dummy MUX 340. In this event, the dummy MUX 340 blocks the application of the signal to the output terminal of the MUX 330 upon completion of the switching operation of the MUX 330 between the different voltages.

**[0057]** The transducer 320 converts the pulse of the electrical signal generated by the pulse generator 310 to an ultrasound signal and transmits the ultrasound signal to the object in step S740. In addition, the transducer 320 converts the ultrasound signal reflected and returned from an interface between different media to the corresponding electrical signal and transmits the same to the signal processor. Before the transducer 320, the spike voltage from the switching operation of the MUX 330 is minimized by the signal applied from the dummy MUX 340 to the output terminal of the MUX 330, and accordingly, only the pulse of the electrical signal generated by the pulse generator 310 remains to be presented for the signal conversion.

**[0058]** FIG. 8 is a flowchart illustrating another example of an ultrasound diagnostic imaging method according to at least one embodiment of the present disclosure.

**[0059]** Referring to FIGs. 6 and 8, the pulse generator 610 generates a pulse of an electrical signal in step S810. The pulse generator 610 excites the transducer 620 with pulse width  $T_p$  reduced as illustrated in FIG. 4 for increasing the axial resolution of the pulse and with pulse size  $V$  sufficiently enlarged for increasing the signal/noise (S/N) ratio.

**[0060]** The MUX 630 performs a switching operation between different applied voltages and enables the pulse of the electrical signal generated by the pulse generator 610 to be transmitted through a selected channel in step S820.

**[0061]** When the switching operation is performed between the different voltages applied to the MUX 630, the reverse voltage application unit 640 may form a virtual spike voltage based on an average value of spike voltages acquired empirically or a maximum value and a minimum value of the spike voltages acquired empirically in step S830. Further, the step reverses the formed spike voltage, and applies the reversed spike voltage to the output terminal of the MUX 630, in response to the switching operation of the MUX 630. The reverse voltage of the spike voltage described herein is only an example, and the reverse voltage may be formed in variously modified ways.

**[0062]** The transducer 620 converts the pulse of the electrical signal generated by the pulse generator 610 to the ultrasound signal and transmits the ultrasound signal to an object, and converts the ultrasound signal reflected and returned from an interface between different media to the corresponding electrical signal and transmits the same to the signal processor in step S840. Before the transducer 620, the spike voltage from the switching operation of the MUX 630 is minimized by the signal applied from the dummy MUX 640 to the output terminal of the MUX 630, and accordingly, only the pulse of the electrical signal generated by the pulse generator 610 remains to be presented for the signal conversion.

**[0063]** In the description above, although all of the components of the embodiments of the present disclosure have been explained as being assembled or operatively connected as a unit, one of ordinary skill in the art would understand the present disclosure is not limited to such embodiments. Rather, within some embodiments of the present disclosure, the respective components are selectively and operatively combined in any number of ways. Every one of the components are capable of being implemented alone in hardware or combined in part or as a whole and implemented in a computer program having program modules residing in computer readable media and causing a processor or microprocessor to execute functions of the hardware equivalents. Codes or code segments to constitute such a program are understood by a person skilled in the art. The computer program is stored in a non-transitory computer readable media, which in operation realizes the embodiments of the present disclosure. The computer readable media includes magnetic recording media, optical recording media or carrier wave media, in some embodiments.

**[0064]** In addition, one of ordinary skill would understand terms like 'include', 'comprise', and 'have' to be interpreted in default as inclusive or open rather than exclusive or closed unless expressly defined to the contrary. All the terms that are technical, scientific or otherwise agree with the meanings as understood by a person skilled in the art unless defined to the contrary. One of ordinary skill would understand common terms as found in dictionaries are interpreted in the context of the related technical writings not too ideally or impractically unless the present disclosure expressly defines them so.

**[0065]** Although exemplary embodiments of the present disclosure have been described for illustrative purposes, those skilled in the art will appreciate that various modifications, additions and substitutions are possible, without departing from the various characteristics of the disclosure. Therefore, exemplary embodiments of the present disclosure have been described for the sake of brevity and clarity. Accordingly, one of ordinary skill would understand the scope of the disclosure is not limited by the explicitly described above embodiments but by the claims and equivalents thereof.

## CROSS-REFERENCE TO RELATED APPLICATION

**[0066]** If applicable, this application claims priority under 35 U.S.C §119(a) of Patent Application No. 10-2011-0035207, filed on April 15, 2011 in Korea, the entire content of which is incorporated herein by reference. In addition, this non-provisional application claims priority in countries, other than the U.S., with the same reason based on the Korean Patent Application, the entire content of which is hereby incorporated by reference.

### Claims

1. An ultrasound diagnostic imaging apparatus, comprising:

a pulse generator configured to generate a pulse of an electric signal;  
 a transducer configured to convert the pulse of the electric signal generated by the pulse generator into an ultrasonic wave signal and to transmit the ultrasonic wave signal to an object;  
 a multiplexer (MUX) configured to select one or more channels corresponding to at least one element of the transducer and to perform a switching operation between different applied voltages; and  
 a dummy MUX configured to apply, to an output end of the MUX, a reverse signal of an output signal of the MUX by performing an inverse switching operation which is opposite to the switching operation by the MUX, when the MUX performs the switching operation between the different applied voltages.

2. The ultrasound diagnostic imaging apparatus of claim 1, wherein the dummy MUX blocks the reverse signal applied to the output end of the MUX upon completion of the switching operation between the different applied voltages.

3. The ultrasound diagnostic imaging apparatus of claim 1, wherein the MUX performs the switching operation between applied voltages of +100 V and -100 V.

4. The ultrasound diagnostic imaging apparatus of claim 3, wherein the dummy MUX performs the inverse switching operation from -100 V to +100 V when the switching operation is performed from +100 V to -100 V for the selected channel.

5. The ultrasound diagnostic imaging apparatus of claim 3, wherein the dummy MUX performs the inverse switching operation from +100 V to -100 V when the switching operation is performed from -100 V to +100 V for the selected channel.

6. An ultrasound diagnostic imaging apparatus, comprising:

a pulse generator configured to generate a pulse of an electric signal;  
 a transducer configured to convert the pulse of the electric signal generated by the pulse generator into an ultrasonic wave signal and to transmit the ultrasonic wave signal to an object;  
 a multiplexer (MUX) configured to select one or more channels corresponding to at least one element of the transducer and to perform a switching operation between different applied voltages; and  
 a reverse voltage application unit configured to apply, to an output end of the selected channel, a reverse voltage of a spike voltage resulting from the switching operation, when the MUX performs the switching operation.

7. The ultrasound diagnostic imaging apparatus of claim 6, wherein the reverse voltage application unit applies the reverse voltage simultaneously of the switching operation by the MUX and blocks the application of the reverse voltage upon completion of the switching operation by the MUX from one voltage to another voltage.

8. The ultrasound diagnostic imaging apparatus of claim 6, wherein the MUX performs a switching operation between applied voltages of +100 V and -100 V.

9. The ultrasound diagnostic imaging apparatus of claim 8, wherein the reverse voltage application unit is responsive to the switching operation of the MUX from +100 V to -100 V for applying, to the output end of the selected channel, a spike voltage generated from an inverse switching operation from -100 V to +100 V.

10. The ultrasound diagnostic imaging apparatus of claim 8, wherein the reverse voltage application unit is responsive to the switching operation of the MUX from -100 V to +100 V for applying, to the output end of the selected channel,

a spike voltage generated from an inverse switching operation from +100 V to -100 V.

11. An ultrasound diagnostic imaging method, comprising:

5           generating a pulse of an electric signal;  
          performing, by a multiplexer (MUX), a selection of one or more channels corresponding to at least one element  
          of the transducer and a switching operation between different applied voltages;  
          applying, to an output end of the MUX, a reverse signal of an output signal of the MUX by performing an inverse  
10          switching operation which is opposite to the switching operation by the MUX; and  
          converting the pulse of the electric signal outputted through the selected channel into an ultrasonic wave signal  
          and transmitting the ultrasonic wave signal to an object.

12. The ultrasound diagnostic imaging method of claim 11, wherein the applying of the reverse signal comprises blocking  
15          the application of the reverse signal to the output end of the MUX upon completion of the switching operation between  
          the different applied voltages.

13. The ultrasound diagnostic imaging method of claim 11, wherein the performing of the channel selection and the  
          switching operation comprises performing the switching operation between applied voltages of +100 V and - 100 V.

20          14. The ultrasound diagnostic imaging method of claim 13, wherein the applying of the reverse signal comprises per-  
          forming a voltage application by the inverse switching operation from -100 V to +100 V when the switching operation  
          is performed for the selected channel from +100 V to -100 V.

25          15. The ultrasound diagnostic imaging method of claim 13, wherein the applying of the reverse signal comprises per-  
          forming a voltage application by the inverse switching operation from +100 V to -100 V when the switching operation  
          is performed for the selected channel from -100 V to +100 V.

16. An ultrasound diagnostic imaging method, comprising:

30           generating a pulse of an electric signal;  
          performing, by a multiplexer (MUX), a selection of one or more channels corresponding to at least one element  
          of the transducer and a switching operation between different applied voltages;  
          applying, to an output end of the selected channel, a reverse voltage of a spike voltage resulting from the  
          switching operation of the MUX; and  
35          converting the pulse of the electric signal outputted through the selected channel into an ultrasonic wave signal  
          and transmitting the ultrasonic wave signal to an object.

17. The ultrasound diagnostic imaging method of claim 16, wherein the applying of the reverse voltage comprises:

40           applying the reverse voltage simultaneously of the switching operation of the MUX; and  
          blocking the application of the reverse voltage upon completion of the switching operation.

18. The ultrasound diagnostic imaging method of claim 16, wherein the performing of the switching operation comprises  
45          performing the switching operation between applied voltages of +100 V and -100 V.

19. The ultrasound diagnostic imaging method of claim 18, wherein the applying of the reverse voltage comprises  
          applying the spike voltage by an inverse switching operation from -100 V to +100 V when the switching operation  
          of the MUX is performed from +100 to -100.

50          20. The ultrasound diagnostic imaging method of claim 18, wherein the applying of the reverse voltage comprises  
          applying the spike voltage by an inverse switching operation from +100 V to -100 V when the switching operation  
          of the MUX is performed from -100 to +100.

55

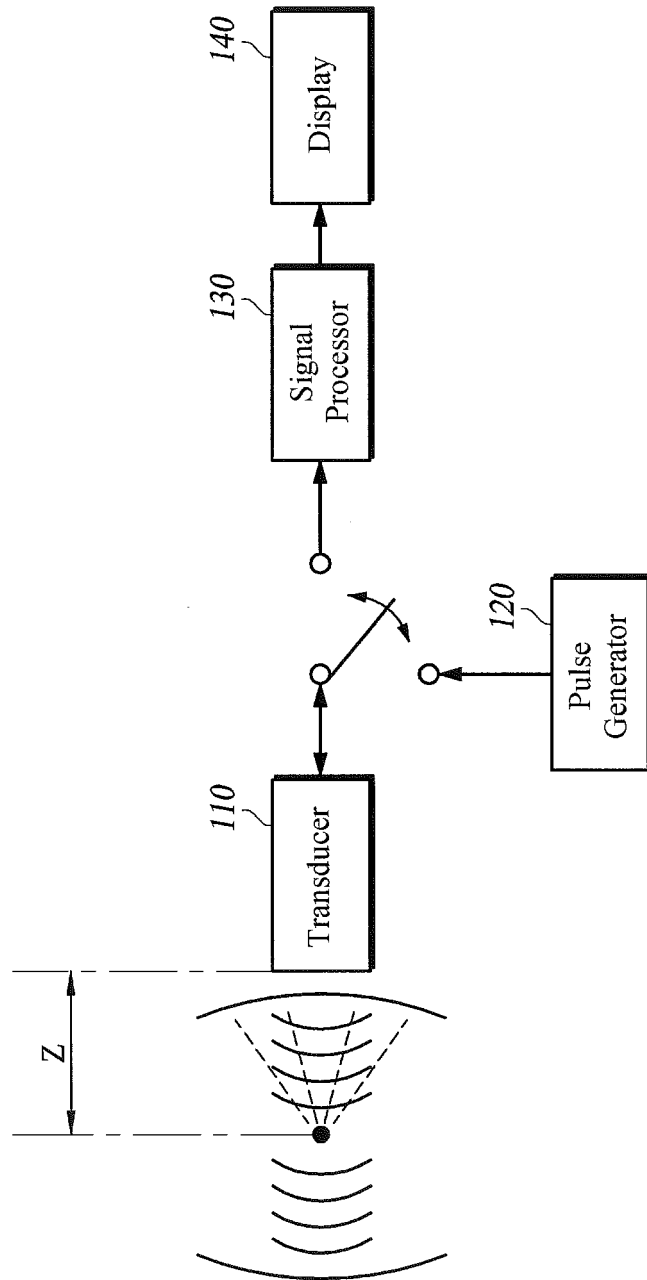

**FIG. 1**

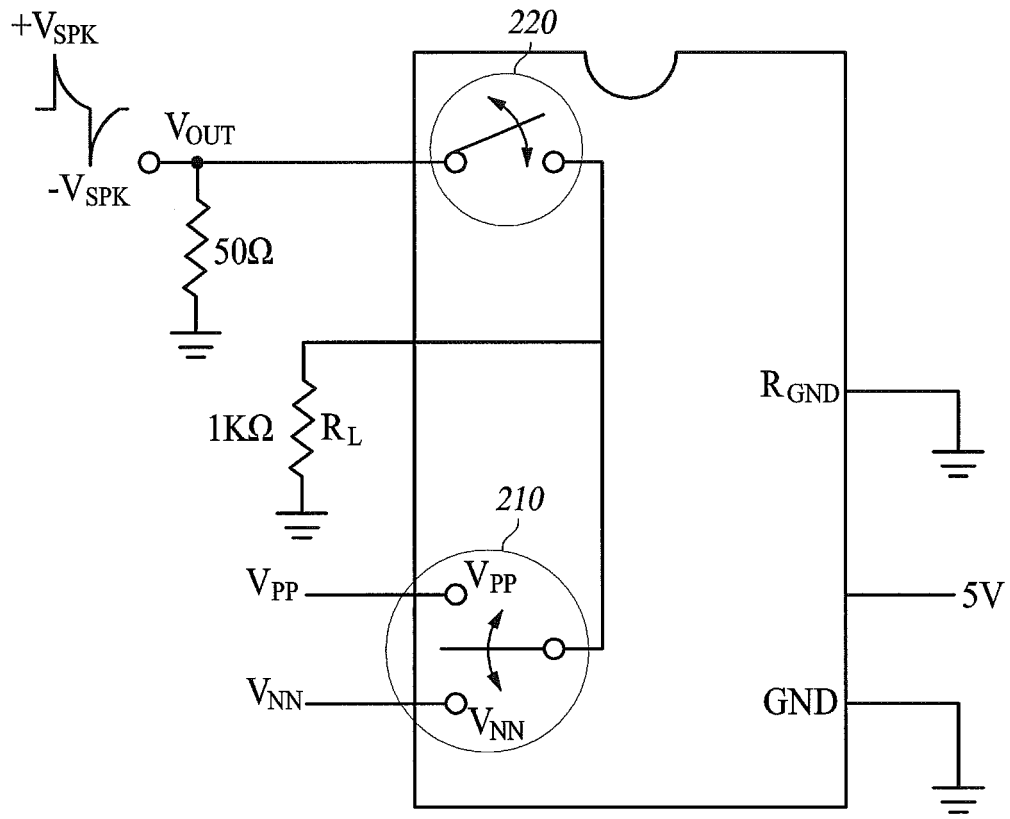

**FIG. 2**

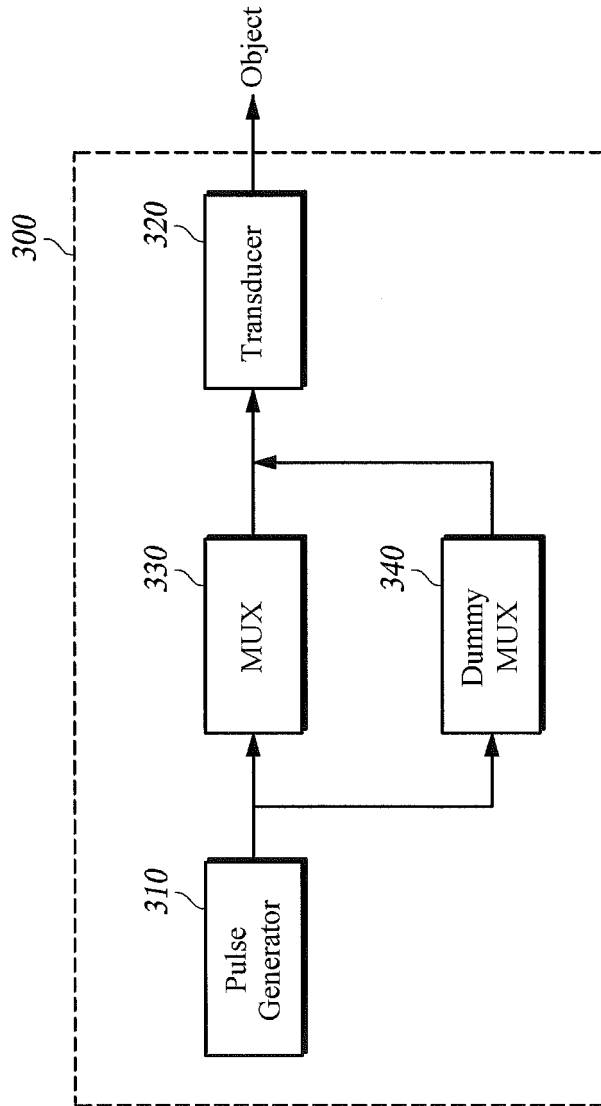

**FIG. 3**

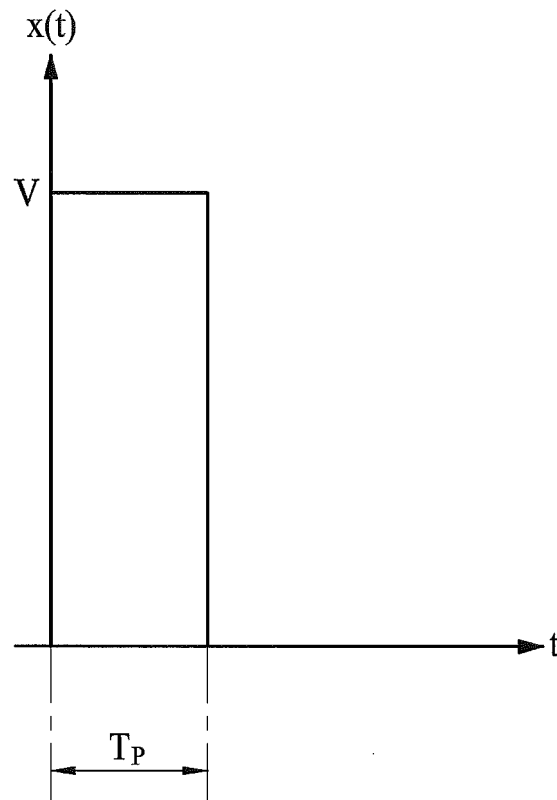

**FIG. 4**

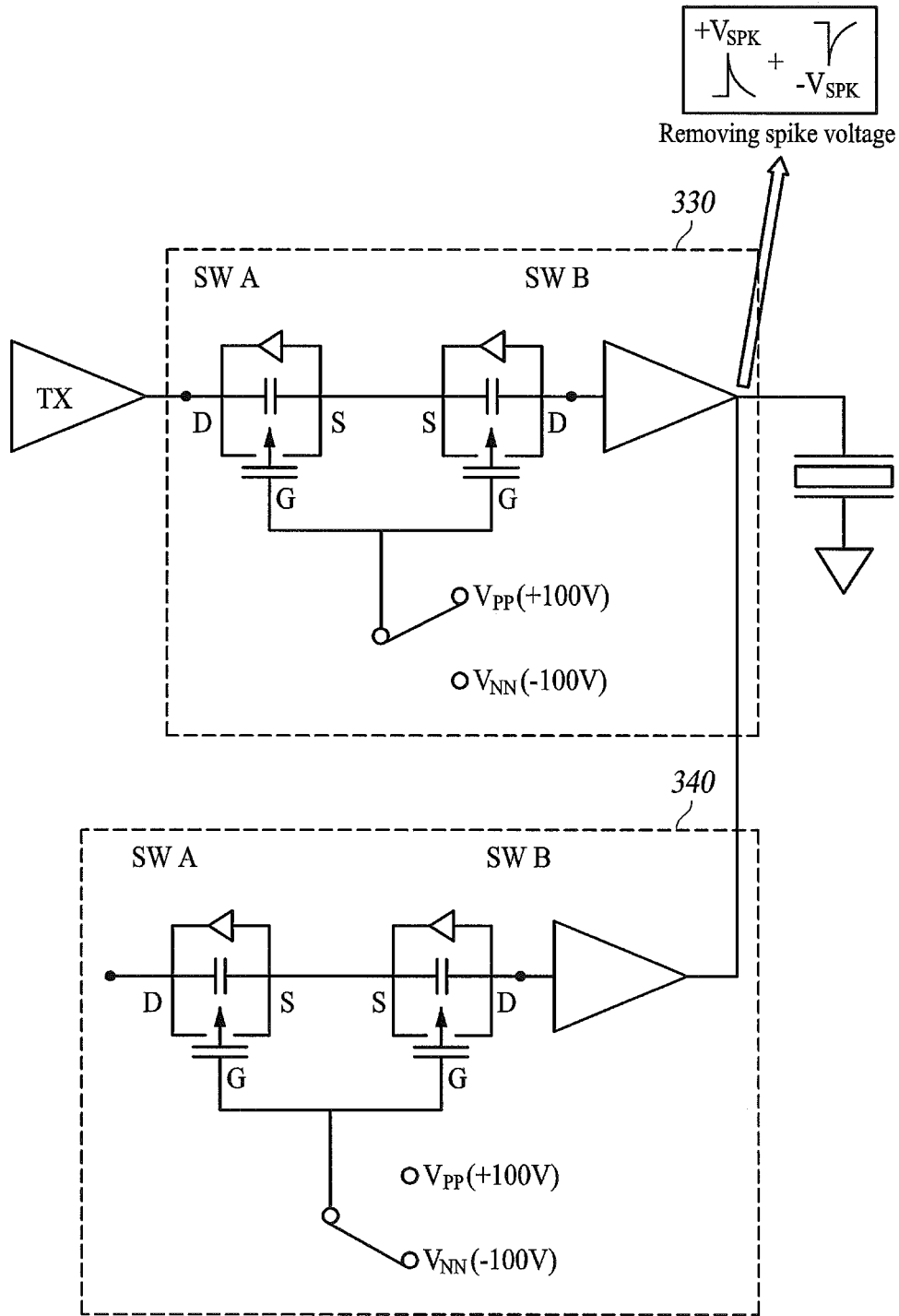

**FIG. 5**

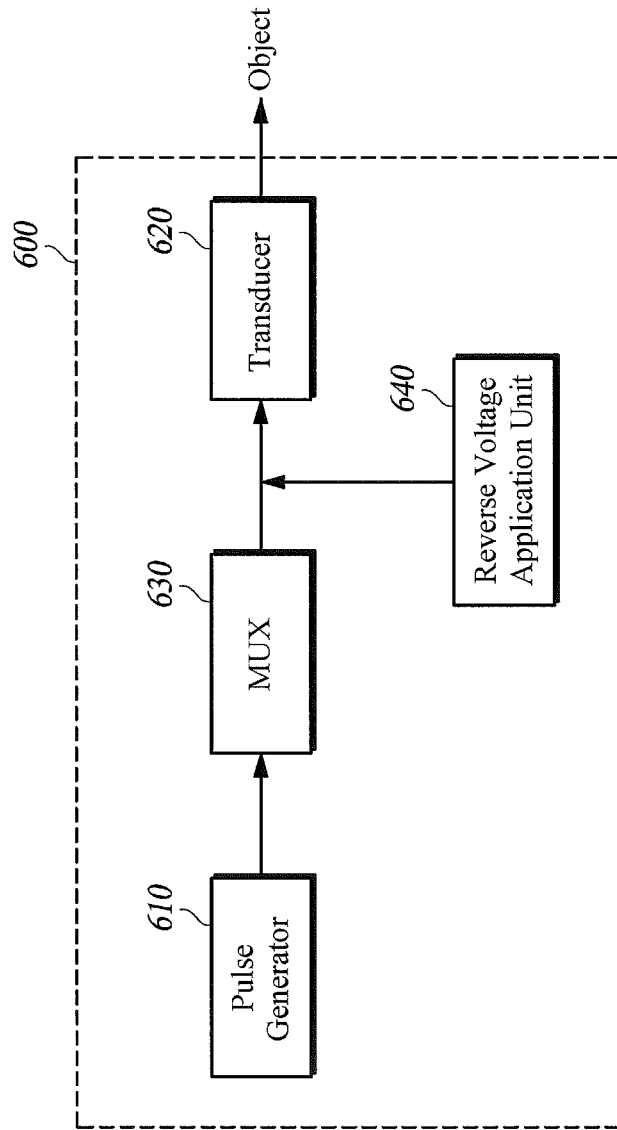

**FIG. 6**

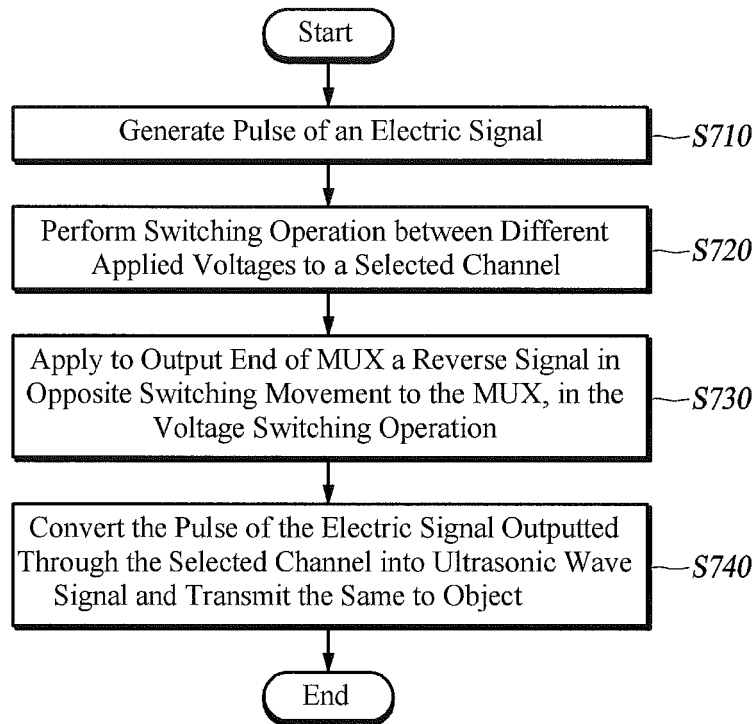

**FIG. 7**

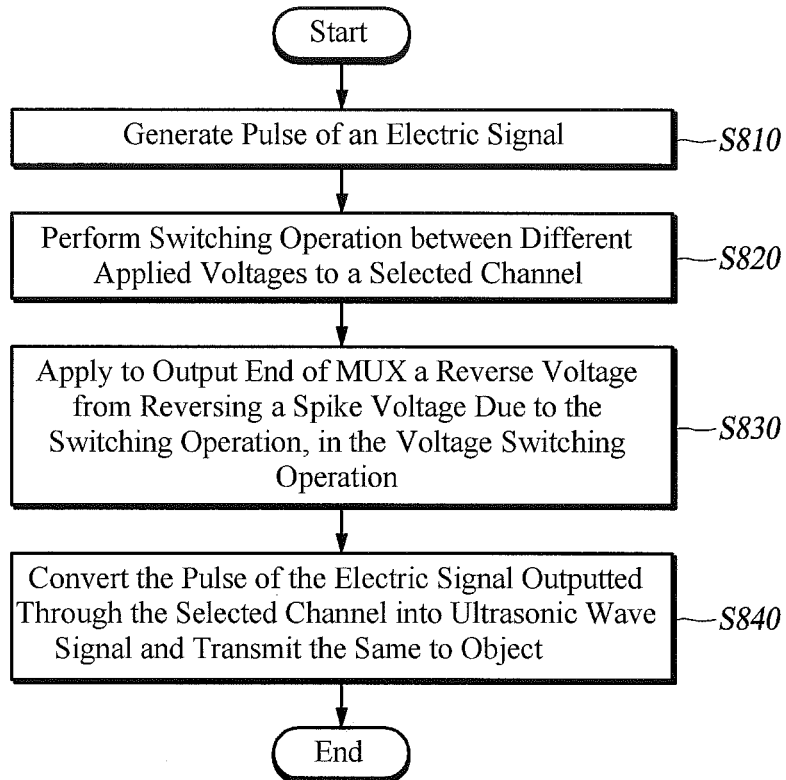

**FIG. 8**

**REFERENCES CITED IN THE DESCRIPTION**

*This list of references cited by the applicant is for the reader's convenience only. It does not form part of the European patent document. Even though great care has been taken in compiling the references, errors or omissions cannot be excluded and the EPO disclaims all liability in this regard.*

**Patent documents cited in the description**

- US 1020110035207 KR [0066]

专利名称(译)	用于诊断超声图像的设备 和用于诊断超声图像的方法		
公开(公告)号	<a href="#">EP2698113A2</a>	公开(公告)日	2014-02-19
申请号	EP2012770545	申请日	2012-04-13
[标]申请(专利权)人(译)	爱飞纽医疗机械贸易有限公司		
申请(专利权)人(译)	ALPINION MEDICAL SYSTEMS CO. , LTD.		
当前申请(专利权)人(译)	ALPINION MEDICAL SYSTEMS CO. , LTD.		
[标]发明人	LEE DAEHYUN CHO SEONGTAEK RHO SEBEOM		
发明人	LEE, DAEHYUN CHO, SEONGTAEK RHO, SEBEOM		
IPC分类号	A61B8/00 G01N29/24 G01S7/52		
CPC分类号	G01S7/5202 A61B8/54 A61B8/56 G01S7/52047		
优先权	1020110035207 2011-04-15 KR		
其他公开文献	EP2698113B1 EP2698113A4		
外部链接	<a href="#">Espacenet</a>		

摘要(译)

公开了一种超声图像设备及其方法。超声诊断成像设备包括脉冲发生器，换能器，多路复用器 ( MUX ) 和伪MUX。脉冲发生器配置为产生电信号的脉冲。换能器被配置为将由脉冲发生器产生的电信号的脉冲转换为超声波信号，并将超声波信号发送到物体。MUX被配置为选择与换能器的至少一个元件相对应的一个或多个通道，并且在不同的施加电压之间执行切换操作。伪MUX被配置为通过执行逆切换操作向MUX的输出端施加MUX的输出信号的反向信号，该逆切换操作与MUX在MUX之间执行切换操作时的切换操作相反。不同的施加电压。

$$V = \sqrt{\frac{B}{\rho}}$$

Equation 1