



(11) **EP 3 143 938 A1**

(12) **EUROPEAN PATENT APPLICATION**

(43) Date of publication:
22.03.2017 Bulletin 2017/12

(51) Int Cl.:
A61B 8/00 (2006.01) H04W 84/12 (2009.01)

(21) Application number: **16196182.6**

(22) Date of filing: **25.07.2012**

(84) Designated Contracting States:
AL AT BE BG CH CY CZ DE DK EE ES FI FR GB GR HR HU IE IS IT LI LT LU LV MC MK MT NL NO PL PT RO RS SE SI SK SM TR

- **KIM, Jung-jun**
Seoul (KR)
- **HAN, Ho-san**
Seoul (KR)
- **HONG, Soon-jae**
Gyeonggi-do (KR)

(30) Priority: **25.07.2011 KR 20110073773**

(62) Document number(s) of the earlier application(s) in accordance with Art. 76 EPC:
12817598.1 / 2 736 417

(74) Representative: **Grootscholten, Johannes A.M. et al**
Arnold & Siedsma
Bezuidenhoutseweg 57
2594 AC The Hague (NL)

(71) Applicant: **Samsung Electronics Co., Ltd.**
Gyeonggi-do 16677 (KR)

Remarks:
This application was filed on 28-10-2016 as a divisional application to the application mentioned under INID code 62.

(72) Inventors:
• **KIM, Kang-sik**
Gyeonggi-do (KR)

(54) **WIRELESS COMMUNICATION METHOD OF PROBE FOR ULTRASOUND DIAGNOSIS AND APPARATUS THEREFOR**

(57) A probe apparatus for ultrasound diagnostic imaging associates with a mmWave-based Personal Basic Service Set (PBSS), performs pairing with an ultrasonic imaging apparatus, and transmits an echo signal received via a transducer portion of the probe, to the ultrasonic imaging apparatus using a signal channel in a 60 GHz frequency band, thereby obviating the need for a data transmission cable and greatly reducing operator inconvenience.

【Figure 2】

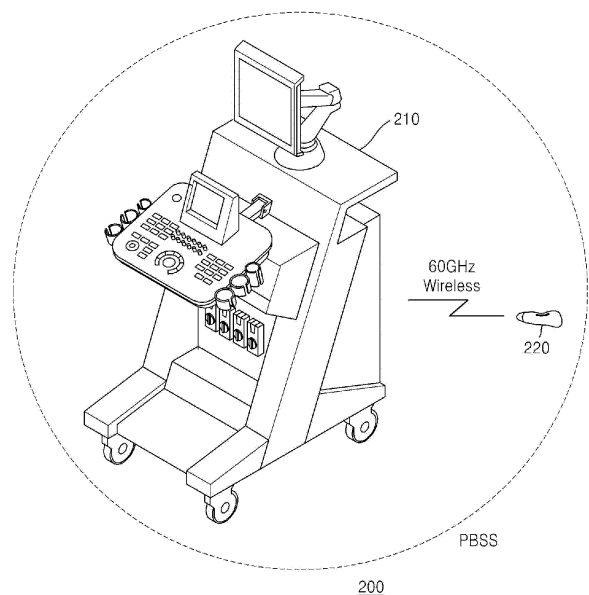

EP 3 143 938 A1

Description

[0001] The present invention relates to a method in which a probe apparatus for ultrasound diagnosis transmits an echo signal to an ultrasonic imaging apparatus, and an apparatus for performing the method.

[0002] Ultrasound diagnostic imaging systems transmit ultrasonic signals from the surface of a human body toward a predetermined region inside the human body and acquire tomographic images of soft-tissue or blood flow by using information obtained from an ultrasonic signal reflected by liquids or tissue inside the human body. Advantages of an ultrasound system are its relatively small size, low cost, real-time display, and the fact that the subject is not exposed to ionizing radiation (e.g., X-rays). Therefore, ultrasound imaging systems are widely used along with other types of image diagnostic devices, such as an X-ray diagnostic device, a computerized tomography (CT) scanner, a magnetic resonance imaging (MRI) device, a nuclear medicine (gamma camera) diagnostic device, etc.

[0003] FIG. 1 illustrates a typical ultrasound diagnostic imaging system 150 as currently in use today, which diagnostic includes a probe 110 for transceiving ultrasonic signals, and an ultrasound diagnostic imaging system body 100, namely, an ultrasonic imaging apparatus 100, to which the probe 110 is connected via a cable 120.

[0004] In a conventional ultrasound diagnostic imaging system illustrated in Fig. 1, the cable 120 causes much inconvenience to a person using the ultrasound imaging system 150 to perform an ultrasound test, due to the length (usually 1-2m), thickness and weight of the cable 120.

[0005] The present invention provides a method and apparatus for wirelessly transmitting an echo signal to an ultrasonic imaging apparatus without loss.

[0006] According to the present invention, the need for a data transmission cable is obviated and operator inconvenience is greatly reduced.

FIG. 1 illustrates a prior art ultrasound diagnostic imaging system;

FIG. 2 illustrates an ultrasound diagnostic imaging system according to an embodiment of the present invention;

FIG. 3 is a flowchart illustrating a communication process of a probe, according to an embodiment of the present invention;

FIG. 4 is a flowchart illustrating a process in which the probe performs pairing with an ultrasonic imaging apparatus, according to an embodiment of the present invention;

FIG. 5 is a flowchart illustrating a pairing process according to an embodiment of the present invention;

FIG. 6 is a flowchart illustrating a pairing process according to another embodiment of the present invention;

FIG. 7 is a flowchart illustrating a pairing process according to another embodiment of the present invention;

FIG. 8 is a flowchart illustrating a pairing process according to another embodiment of the present invention;

FIG. 9 is a flowchart illustrating a pairing process according to another embodiment of the present invention;

FIG. 10 is a flowchart illustrating a process of controlling a link margin, according to an embodiment of the present invention;

FIG. 11 illustrates a format illustrating a link margin response frame according to an embodiment of the present invention; and

FIG. 12 is a block diagram illustrating a structure of a probe apparatus according to an embodiment of the present invention.

[0007] According to an aspect of the present invention, there is provided a probe apparatus for ultrasound diagnostic imaging, the probe apparatus comprising: an association performing unit which performs a procedure for associating the probe apparatus with a mmWave-based wireless network; a frame generation unit which generates a data frame with a format suitable for the mmWave-based wireless network, by using an echo signal received via a transducer; and a wireless communication unit which transmits the data frame to an ultrasonic imaging apparatus using a signal channel in a 60 GHz frequency band via the mmWave-based wireless network.

[0008] The mmWave-based wireless network may be a Personal Basic Service Set (PBSS) that follows the WiGig standard of the Wireless Gigabit Alliance (WGA), and the ultrasonic imaging apparatus operates as a PBSS control point (PCP) of the PBSS.

[0009] The probe apparatus may further include a beam forming unit which performs mmWave beamforming of the signal in the 60 GHz frequency band in order to transmit the data frame to the ultrasonic imaging apparatus.

[0010] According to another aspect of the present invention, there is provided a probe apparatus for ultrasound diagnostic imaging, the probe apparatus comprising: a beacon monitoring unit which monitors for the reception of a mmWave beacon from an ultrasonic imaging apparatus of a Personal Basic Service Set (PBSS) with which the probe apparatus is not yet associated, when a user command for making a pairing request is received; a peer determination unit which detects an ultrasonic imaging apparatus which is to be paired with the probe apparatus by using first pairing information included in a received mmWave beacon; an association performing unit which performs a procedure for associating the probe apparatus with a PBSS of the ultrasonic imaging apparatus by using a basic service set ID (BSSID) included in the received mmWave beacon; and a pairing request unit which transmits second pairing information to the

ultrasonic imaging apparatus via the PBSS, wherein the first pairing information represents that the ultrasonic imaging apparatus has been requested by a user to perform pairing, and the second pairing information represents that the probe apparatus has been requested by the user to perform pairing.

[0011] The first pairing information may comprise a medium access control (MAC) address of the ultrasonic imaging apparatus and push button configuration (PBC) information representing that a button for requesting pairing by using a PBC technique has been pressed in the ultrasonic imaging apparatus, and the second pairing information comprises a MAC address of the probe apparatus and PBC information representing that a button for requesting pairing by using the PBC technique has been pressed in the probe apparatus.

[0012] The probe apparatus may further comprise a wireless communication unit which transmits an echo signal received via a transducer portion of the probe, to the ultrasonic imaging apparatus via a signal channel in a 60 GHz frequency band via the PBSS of the ultrasonic imaging apparatus.

[0013] The probe apparatus may further comprise a beam forming unit which performs mmWave beamforming with the ultrasonic imaging apparatus.

[0014] According to another aspect of the present invention, there is provided a probe apparatus for ultrasound diagnostic imaging, the probe apparatus comprising: a link formation unit which forms a communication link with an ultrasonic imaging apparatus in a PBSS that uses mmWaves; a margin information processing unit which extracts information about a link margin of the communication link from a link margin response frame received from the ultrasonic imaging apparatus; and a margin control unit which controls the probe apparatus to perform at least one of a change in transmission power of an echo signal, a change in a modulation and coding scheme (MCS) to be applied to the echo signal, a change in beam forming with the ultrasonic imaging apparatus, and a change in channel frequency within a 60 GHz frequency band based on the information.

[0015] The margin information processing unit may transmit a link margin request frame requesting information about the link margin to the ultrasonic imaging apparatus, and the link margin response frame may be received in response to the link margin request frame.

[0016] The link margin request frame may comprise at least one of a category field indicating what kind of frame the link margin request frame belongs to, an action field indicating that the link margin response frame is a link margin request frame from among frames categorized into the kind of frame determined by the category field, and a transmission number field representing the number of times the link margin request frame is transmitted.

[0017] The link margin response frame may comprise a preferred action field that comprises information that indicates a request for one operation from among the change in the transmission power, the change in the

MCS, the change in beam forming, and the change in channels, to be performed.

[0018] According to another aspect of the present invention, there is provided an ultrasound diagnostic system comprising: a probe apparatus which is associated with a mmWave-based wireless network, which probe apparatus transmits an echo signal received via a transducer portion of the probe apparatus to an ultrasonic imaging apparatus using a signal channel in a 60 GHz frequency band via the mmWave-based wireless network; and the ultrasonic imaging apparatus which generates an ultrasonic image by using the echo signal received in the 60 GHz frequency band via the mmWave-based wireless network.

[0019] The mmWave-based wireless network may be a personal basic service set (PBSS) that follows the Wi-Gig standard of the Wireless Gigabit Alliance (WGA), and the ultrasonic imaging apparatus operates as a PBSS control point (PCP) of the PBSS.

[0020] The following description, with reference to the accompanying drawings, is provided to assist a person of ordinary skill in the art with a comprehensive understanding of exemplary embodiments of the invention. The description includes various specific details to assist in that understanding but these details are to be regarded as merely exemplary. Accordingly, those of ordinary skill in the art will recognize that various changes and modifications of the exemplary embodiments described herein can be made without departing from the spirit of the invention and the scope of the appended claims. Also, descriptions of well-known functions and constructions may be omitted for clarity and simplicity so as not to obscure appreciation of the present invention by a person of ordinary skill with such well-known functions and constructions.

[0021] The terms and words used in the following description and claims are not limited to the bibliographical meanings, but, are merely used by the inventor to enable a clear and consistent understanding of the invention. Accordingly, it should be apparent to those skilled in the art that the following description of exemplary embodiments of the present invention are provided for illustration purposes only and not for the purpose of limiting the invention as defined by the appended claims.

[0022] Expressions such as "at least one of", "when preceding a list of elements, refers to at least one of the entire list of elements and is not intended to be limited individual elements of the list.

[0023] It is to be understood that the singular forms "a", "an", and "the" include plural references unless the context clearly dictates otherwise. Thus, for example, reference to "a component surface" typically includes reference to one or more of such surfaces.

[0024] Finally, the term "substantially" typically means that the recited characteristic, parameter, or value need not be achieved exactly, but that deviations or variations, including for example, tolerances, measurement error, measurement accuracy limitations and other factors

known to those skilled in the art, may occur in amounts that do not preclude the effect the characteristic was intended to provide.

[0025] FIG. 2 illustrates an ultrasound diagnostic imaging system 200 according to an embodiment of the present invention, which diagnostic includes an ultrasonic imaging apparatus 210 and a probe 220 including an ultrasonic wave transducer.

[0026] The probe 220 and the ultrasonic imaging apparatus 210 are associated with a same mmWave (millimeter Wave) -based wireless network, and the probe 220 transmits an echo signal received via the transducer portion of the probe, to the ultrasonic imaging apparatus 210 using one or more signal channels in the 60 GHz frequency band. The ultrasonic imaging apparatus 210 generates ultrasonic images in various modes, such as B-mode, color flow, and Doppler, by using the ultrasound echo signal transmitted thereto using the 60 GHz frequency band signal channel, and displays the ultrasonic images.

[0027] The probe 220 generates an ultrasonic signal by applying one or more pulses to an ultrasonic oscillator of a transducer. Once generated, the ultrasonic signal is reflected by a target (such as structures in a human body) and is received as an echo signal by the transducer. The transducer converts the echo signal into an electrical signal, and then requires a high bandwidth communication channel on the order of multiple gigabytes, to wirelessly transmit the electrical signal, and also so as to not interfere with other wireless electronic apparatuses during wireless transmission of the echo signal.

[0028] To this end, according to embodiments of the present invention, an echo signal is wirelessly transmitted via a wireless network that uses millimeter waves. For example, a wireless communication technique based on the WiGig standard of the Wireless Gigabit Alliance (WGA) may be used.

[0029] The WiGig standard is sufficient to transmit an echo signal that has been converted into digital data because the WiGig standard supports data transmission rates up to 7 Gbps, and may steer a signal direction by using the directionality of beams to minimize interference with other systems. The WiGig standard as a local-distance wireless communication standard is also generally suitable for ultrasonic test environments where a probe and an ultrasonic imaging apparatus are close to each other, and using the WiGig standard consumes less power than other wireless communication standards and thus may minimize the weight and size of battery which is to be built into the probe. The dashed line circle in FIG 2 enclosing probe 220 and the ultrasonic imaging apparatus 210 denotes a wireless communication network with which the probe and imaging apparatus communicate with each other, and may be a personal basic service set (PBSS) of the WiGig standard, as explained in more detail below.

[0030] *43FIG. 3 is a flowchart of a communication process performed by a probe, according to an embod-

iment of the present invention.

[0031] In operation 301, the probe performs a procedure in order to become associated with a PBSS mmWave-based wireless network. In the PBSS, at least one station needs to operate as a PBSS control point (PCP) that manages the PBSS. However, the probe is limited in its size and weight, and thus it may be preferred that the ultrasonic imaging apparatus 210 may operate as the PCP. Alternatively, both the ultrasonic imaging apparatus and the probe may operate as a station, and another device may operate as the PCP in the PBSS.

[0032] In operation 302, the probe generates a data frame with a format suitable for the mmWave-based wireless network, by using an echo signal received via the transducer.

[0033] In operation 303, the probe transmits the data frame to the ultrasonic imaging apparatus using a signal in a 60 GHz frequency band. The ultrasonic imaging apparatus (such as 210 of FIG 2) receives the data frame, generates therefrom an ultrasonic image via signal processing, and displays the ultrasonic image.

[0034] FIG. 4 is a flowchart of a process in which the probe performs pairing with the ultrasonic imaging apparatus, according to an embodiment of the present invention.

[0035] The PBSS is an ad-hoc structure that performs direct communication between stations without passing through a PCP. Accordingly, the probe and the ultrasonic imaging apparatus need to be subjected to a process of recognizing themselves as peer devices and setting a communication protocol to perform mutual communication. This process is referred to as pairing. A push button configuration (PBC) method may be used to perform pairing between the probe and the ultrasonic imaging apparatus. In other words, when a user pushes pairing buttons included in the probe and the ultrasonic imaging apparatus simultaneously (or within a short time interval therebetween), the probe and the ultrasonic imaging apparatus are paired.

[0036] In operation 401, when a user command for making a pairing request is input, that is, when a pairing button is pressed, the probe receives a mmWave beacon frame (hereinafter, referred to as a beacon frame) of the PBSS not yet associated. Before the user command for making a pairing request is input, the probe is not associated with the PBSS of the ultrasonic imaging apparatus, and thus does not parse a beacon frame broadcast from the PBSS to which the ultrasonic imaging apparatus belongs, but discards it. However, when a user presses the pairing buttons, the probe starts monitoring an externally received beacon frame.

[0037] In operation 402, the probe detects the ultrasonic imaging apparatus which is to be paired with the probe by using first pairing information included in the beacon frame. It is assumed that the ultrasonic imaging apparatus has already belonged to the PBSS, and the ultrasonic imaging apparatus may operate as a PCP or a general station rather than the PCP in the PBSS. When

a user presses the pairing button included in the ultrasonic imaging apparatus to perform pairing, the PCP of the PBSS broadcasts the first pairing information, representing that the ultrasonic imaging apparatus has requested pairing, via a beacon frame. The first pairing information may include PBC information representing that the pairing button of the ultrasonic imaging apparatus has been pressed, and a medium access control (MAC) address of the ultrasonic imaging apparatus.

[0038] In operation 403, the probe is associated with the PBSS of the ultrasonic imaging apparatus by using Basic Service Set ID (BSSID) included in the beacon frame. Although the probe is associated with the PBSS after determining a peer device (operation 402) in the present embodiment, operation 403 may be performed before operation 402.

[0039] In operation 404, the probe transmits second pairing information to the ultrasonic imaging apparatus. The second pairing information represents that the probe has requested pairing, and may include PBC information representing that the pairing button of the probe has been pressed, and a MAC address of the probe.

[0040] FIG. 5 is a flowchart of a pairing process according to another embodiment of the present invention where it is assumed that both an ultrasonic imaging apparatus 510 and a probe 520 are initially driven, that is, the ultrasonic imaging apparatus 510 did not yet generate any PBSSs and the probe 520 is not yet associated with any PBSSs.

[0041] In a first operation, a pairing button included in the ultrasonic imaging apparatus 510 is pressed by a user.

[0042] In a second operation, the ultrasonic imaging apparatus 510, in response to the user pressing the pairing button, generates a PBSS and becomes operational so as to serve as a PCP of the PBSS.

[0043] In a third operation, the ultrasonic imaging apparatus 510 broadcasts a beacon frame including first pairing information PI_1 . The first pairing information PI_1 may include PBC information representing that the pairing button included in the ultrasonic imaging apparatus 510 has been pressed, and a MAC address of the ultrasonic imaging apparatus 510.

[0044] At this time, even when the probe 520 is turned on and is physically located at a distance capable of receiving a beacon of the ultrasonic imaging apparatus 510, the probe 520 does not parse the beacon frame but discards it because the probe 520 is not yet associated with the PBSS of the ultrasonic imaging apparatus 510. Accordingly, the probe 520 does not react to the beacon frame received in the third operation.

[0045] Although the first pairing information PI_1 is broadcast via the beacon frame in a beacon section in the present embodiment, the ultrasonic imaging apparatus 510 may broadcast the first pairing information PI_1 in a time section other than the beacon section.

[0046] In a fourth operation, a pairing button included in the probe 520 is pressed by the user. Accordingly, the

probe 520 starts monitoring externally received beacon frames without discarding them.

[0047] In a fifth operation, the ultrasonic imaging apparatus 510 re-broadcasts the beacon frame including the first pairing information PI_1 .

[0048] In a sixth operation, the probe 520 recognizes the ultrasonic imaging apparatus 510 as a peer device.

[0049] In a seventh operation, the probe 520 transmits an association request frame requesting association with the PBSS to the ultrasonic imaging apparatus 510.

[0050] In an eighth operation, the ultrasonic imaging apparatus 510 transmits to the probe 520 an association response frame approving the association request of the probe 520.

[0051] In a ninth operation, the probe 520 transmits the first pairing information PI_1 and second pairing information PI_2 to the ultrasonic imaging apparatus 510. The second pairing information PI_2 may include PBC information representing that the pairing button included in the probe 520 has been pressed, and a MAC address of the probe 520.

[0052] In a tenth operation, the ultrasonic imaging apparatus 510 recognizes the probe 520 as a peer device by analyzing the second pairing information PI_2 .

[0053] FIG. 6 is a flowchart of a pairing process according to another embodiment of the present invention where, as in the embodiment of FIG. 5, it is assumed that both an ultrasonic imaging apparatus 610 and a probe 620 are initially driven.

[0054] In a first operation, a pairing button included in the ultrasonic imaging apparatus 610 is pressed by a user.

[0055] In a second operation, the ultrasonic imaging apparatus 610 generates a PBSS and serves as a PCP of the PBSS.

[0056] In a third operation, the ultrasonic imaging apparatus 610 broadcasts a beacon frame including first pairing information PI_1 . The first pairing information PI_1 may include PBC information representing that the pairing button included in the ultrasonic imaging apparatus 610 has been pressed, and a MAC address of the ultrasonic imaging apparatus 610.

[0057] At this time, even when the probe 620 is turned on and is physically located at a distance capable of receiving a beacon of the ultrasonic imaging apparatus 610, the probe 620 does not parse the beacon frame but discards it because the probe 620 is not yet associated with the PBSS of the ultrasonic imaging apparatus 610. Accordingly, the probe 620 does not react to the beacon frame received in the third operation.

[0058] In a fourth operation, a pairing button included in the probe 620 is pressed by the user. Accordingly, the probe 620 starts monitoring externally received beacon frames without discarding them.

[0059] In a fifth operation, the ultrasonic imaging apparatus 610 re-broadcasts the beacon frame including the first pairing information PI_1 .

[0060] In a sixth operation, the probe 620 recognizes

the ultrasonic imaging apparatus 610 as a peer device.

[0061] In a seventh operation, the probe 620 transmits the first pairing information PI_1 and second pairing information PI_2 to the ultrasonic imaging apparatus 610. The second pairing information PI_2 may include PBC information representing that the pairing button included in the probe 620 has been pressed, and a MAC address of the probe 620.

[0062] In an eighth operation, the ultrasonic imaging apparatus 610 recognizes the probe 620 as a peer device by analyzing the second pairing information PI_2 .

[0063] In a ninth operation, the probe 620 transmits an association request frame requesting association with the PBSS to the ultrasonic imaging apparatus 610.

[0064] In a tenth operation, the ultrasonic imaging apparatus 610 transmits to the probe 620 an association response frame approving the association request of the probe 620.

[0065] As such, in the embodiment of FIG. 6, in contrast with the embodiment of FIG. 5, the probe 620 is associated with the PBSS after transmitting the second pairing information PI_2 to the ultrasonic imaging apparatus 610.

[0066] FIG. 7 is a flowchart of a pairing process according to another embodiment of the present invention where it is assumed that, while an ultrasonic imaging apparatus 710 is operating as a PCP of a PBSS, a probe 720 is initially driven.

[0067] In a first operation, a pairing button included in the ultrasonic imaging apparatus 710 is pressed by a user.

[0068] In a second operation, the ultrasonic imaging apparatus 710 broadcasts a beacon frame including first pairing information PI_1 . The first pairing information PI_1 may include PBC information representing that the pairing button included in the ultrasonic imaging apparatus 710 has been pressed, and a MAC address of the ultrasonic imaging apparatus 710.

[0069] At this time, even when the probe 720 is turned on and is physically located at a distance capable of receiving a beacon frame of the ultrasonic imaging apparatus 710, the probe 720 does not parse the beacon frame but discards it because the probe 620 is not yet associated with the PBSS of the ultrasonic imaging apparatus 710. Accordingly, the probe 720 does not react to the beacon frame received in the second operation.

[0070] In a third operation, a pairing button included in the probe 720 is pressed by the user. Accordingly, the probe 720 starts monitoring externally received beacon frames without discarding them.

[0071] In a fourth operation, the ultrasonic imaging apparatus 710 re-broadcasts the beacon frame including the first pairing information PI_1 .

[0072] In a fifth operation, the probe 720 recognizes the ultrasonic imaging apparatus 710 as a peer device.

[0073] In a sixth operation, the probe 520 is associated with the PBSS of the ultrasonic imaging apparatus 710.

[0074] In a seventh operation, the probe 520 transmits second pairing information PI_2 to the ultrasonic imaging

apparatus 710. The second pairing information PI_2 may include PBC information representing that the pairing button included in the probe 720 has been pressed, and a MAC address of the probe 720.

[0075] In an eighth operation, the ultrasonic imaging apparatus 710 recognizes the probe 720 as a peer device by analyzing the second pairing information PI_2 .

[0076] FIG. 8 is a flowchart of a pairing process according to another embodiment of the present invention where, similar to the embodiment of FIG. 7, it is assumed that while an ultrasonic imaging apparatus 810 is already operating as a PCP of a PBSS, a probe 820 is initially driven.

[0077] In a first operation, a pairing button included in the ultrasonic imaging apparatus 810 is pressed by a user.

[0078] In a second operation, the ultrasonic imaging apparatus 810 broadcasts a beacon frame including first pairing information PI_1 . The first pairing information PI_1 may include PBC information representing that the pairing button included in the ultrasonic imaging apparatus 810 has been pressed, and a MAC address of the ultrasonic imaging apparatus 810.

[0079] At this time, even when the probe 820 is turned on and is physically located at a distance capable of receiving a beacon frame of the ultrasonic imaging apparatus 810, the probe 820 does not parse the beacon frame but discards it because the probe 820 is not yet associated with the PBSS of the ultrasonic imaging apparatus 810. Accordingly, the probe 820 does not react to the beacon frame received in the second operation.

[0080] In a third operation, a pairing button included in the probe 820 is pressed by the user. Accordingly, the probe 820 starts monitoring externally received beacon frames without discarding them.

[0081] In a fourth operation, the ultrasonic imaging apparatus 810 re-broadcasts the beacon frame including the first pairing information PI_1 .

[0082] *95In a fifth operation, the probe 820 recognizes the ultrasonic imaging apparatus 810 as a peer device.

[0083] In a sixth operation, the probe 820 is associated with the PBSS of the ultrasonic imaging apparatus 810 and at the same time transmits second pairing information PI_2 to the ultrasonic imaging apparatus 810. In other words, the probe 820 carries the second pairing information PI_2 in an association request frame and transmits the association request frame including the second pairing information PI_2 to the ultrasonic imaging apparatus 810.

[0084] In a seventh operation, the ultrasonic imaging apparatus 810 recognizes the probe 820 as a peer device by analyzing the second pairing information PI_2 .

[0085] FIG. 9 is a flowchart of a pairing process according to another embodiment of the present invention. In the embodiment of FIG. 9, it is assumed that an ultrasonic imaging apparatus 910 is operating as a general station rather than a PCP 920 of a PBSS even when the ultrasonic imaging apparatus 910 already belongs to the

PBSS, and that a probe 930 is initially driven.

[0086] In a first operation, a pairing button included in the ultrasonic imaging apparatus 910 is pressed by a user.

[0087] In a second operation, the ultrasonic imaging apparatus 910 transmits to a PCP 920 first pairing information PI_1 representing that the ultrasonic imaging apparatus 910 needs to perform pairing. The first pairing information PI_1 may include PBC information representing that the pairing button included in the ultrasonic imaging apparatus 910 has been pressed, and a MAC address of the ultrasonic imaging apparatus 910.

[0088] In a third operation, the PCP 920 broadcasts a beacon frame including the first pairing information PI_1 . Since the probe 930 is not yet associated with the PBSS, the probe 930 does not parse the beacon frame but discards the same. As described above, the PCP 920 may broadcast the first pairing information PI_1 in a time section other than the beacon section.

[0089] In a fourth operation, a pairing button included in the probe 930 is pressed by the user. Accordingly, the probe 930 starts monitoring externally received beacon frames.

[0090] In a fifth operation, the PCP 920 re-broadcasts the beacon frame including the first pairing information PI_1 .

[0091] In a sixth operation, the probe 930 recognizes the ultrasonic imaging apparatus 910 as a peer device of the probe 930 by referring to the first pairing information PI_1 .

[0092] In a seventh operation, the probe 930 is associated with the PBSS of the PCP 920.

[0093] In an eighth operation, the probe 930 transmits to the PCP 920 second pairing information PI_2 representing that the probe 930 itself is requested by the user to perform pairing. The second pairing information PI_2 may be included in an association request frame that the probe 930 transmits to the PCP 920 while the probe 930 is being associated with the PBSS.

[0094] In a ninth operation, the PCP 920 broadcasts a beacon frame including the first pairing information PI_1 and the second pairing information PI_2 .

[0095] In a tenth operation, in response to the beacon frame including the first pairing information PI_1 and the second pairing information PI_2 , the ultrasonic imaging apparatus 910 recognizes the probe 930 as a peer device of the ultrasonic imaging apparatus 910.

[0096] As such, according to the embodiments of the present invention, pairing between an ultrasonic imaging apparatus and a probe is performed by a user simply pressing buttons included in an ultrasonic imaging apparatus and a probe. Thus the probe portion of an ultrasound imaging system may be simply and easily replaced, if necessary, while the existing ultrasonic imaging apparatus is being used.

[0097] FIG. 10 is a flowchart of a process of controlling a link margin, according to an embodiment of the present invention.

[0098] The link margin is information used to determine a status of the communication link, and denotes a power level of a reception signal that is required by a current modulation technique. When the value of the link margin is positive, the power of the reception signal is more than necessary. When the value of the link margin is negative, the power of the reception signal is insufficient.

[0099] In operation 1010, a probe forms a communication link with an ultrasonic imaging apparatus via a PBSS. The formation of the communication link denotes completion of preparations for a communication with a peer device, including pairing.

[0100] In operation 1020, the probe receives a link margin response frame including information about the link margin (hereinafter, also referred to as link margin information) from the ultrasonic imaging apparatus, and extracts the link margin information from the link margin response frame. A format of the link margin response frame will be described later with reference to FIG. 11.

[0101] The ultrasonic imaging apparatus calculates the link margin information based on a data frame that the probe transmits in the 60 GHz band, and then informs the probe of the calculated link margin. The link margin response frame may be received every time the probe requests the link margin response frame, or may be transmitted by the ultrasonic imaging apparatus periodically without special requests or whenever the state of a link degrades.

[0102] In operation 1030, the probe adjusts the link margin based on the link margin information. To adjust the link margin, the probe may perform at least one of a change in transmission power, a change in a modulation and coding scheme (MCS), a change in beam forming, and a change in channel frequency within the 60 GHz band.

[0103] FIG. 11 illustrates a format of a link margin response frame 1100 according to an embodiment of the present invention.

[0104] As illustrated in FIG. 11, the link margin response frame 1100 includes a category field 1101, an action field 1102, a transmission number field 1103, a preferred action field 1104, a link margin element field 1105, an unsolicited field 1106, and a data frame ID field 1107.

[0105] The category field 1101 represents what kind of frame the link margin response frame 1100 belongs to. According to the present embodiment, the category field 1101 may indicate that the link margin response frame 1100 is a control frame.

[0106] The action field 1102 indicates that the link margin response frame 1100 is a link margin response frame categorized into a control frame which is the frame type determined by the category field 1101.

[0107] The transmission number field 1103 indicates the number of times the link margin response frame 1100 is transmitted from an ultrasonic imaging apparatus to a probe.

[0108] The preferred action field 1104 indicates one

operation that the ultrasonic imaging apparatus requests from among a change in transmission power, a change in MCS, beam forming, and a channel frequency change. When the link margin response frame 1100 including the preferred action field 1104 is received, the probe may perform the operation indicated by the preferred action field 1104 or may perform an operation for margin adjustment independently without respect to the preferred action field 1104. Although the preferred action field 1104 is illustrated as an independent field of the link margin response frame 1100 in FIG. 11, the preferred action field 1104 may be a subfield of the link margin element field 1105.

[0109] The link margin element field 1105 includes the link margin information and is divided into an element ID field 1108, a length field 1109, a MCS field 1110, and a link margin field 1111.

[0110] The element ID field 1108 indicates that the link margin element field 1105 is a field including the link margin information.

[0111] The length field 1109 indicates a length of the link margin element field 1105.

[0112] The MCS field 1110 indicates an index representing an MCS which is to be changed, when the preferred action field 1104 indicates that the ultrasonic imaging apparatus requests a change in the MCS.

[0113] The link margin field 1111 records information about the link margin calculated by the ultrasonic imaging apparatus.

[0114] The unsolicited field 1106 represents whether the link margin response frame 1100 is received in response to a request frame of the probe. For example, when the link margin response frame 1100 is received in response to a request of the probe, the unsolicited field 1106 may record 0, and otherwise, the unsolicited field 1106 may record a value other than 0. If the probe transmits a link margin request frame (not shown) to the ultrasonic imaging apparatus to request the link margin response frame 1100, the link margin request frame may include at least one of a category field indicating the kind of frame, an action field indicating that the link margin response frame 1100 is a link margin request frame from among frames categorized into the kind of frame indicated by the category field, and a transmission number field representing the number of times the link margin request frame is transmitted.

[0115] The data frame ID field 1107 includes a sequence number of a data frame used when the ultrasonic imaging apparatus calculates the link margin. Through these pieces of information, the probe can recognize a time for calculating the link margin, and thus may adequately control the state of a communication link.

[0116] FIG. 12 is a block diagram of a structure of a probe apparatus 1200 according to another embodiment of the present invention.

[0117] As illustrated in FIG. 12, the probe apparatus 1200 includes a transducer 1201, a receiver beam former 1202, a user interface 1203, and a wireless transceiver

module 1250.

[0118] The wireless transceiver module 1250 includes an association performing unit 1251, a frame generation unit 1252, a margin information processing unit 1253, a margin control unit 1254, a beam forming unit 1255, a wireless communication unit 1256, and a link formation unit 1260. The link formation unit 1260 includes a pairing request unit 1261, a peer determination unit 1262, and a beacon monitoring unit 1263. The wireless transceiver module 1250 may further include other various components such as a battery, an analog to digital converter (ADC), and a low noise amplifier (LNA). This will be apparent to one of ordinary skill in the art, thus no further descriptions thereof are provided.

[0119] The transducer 1201 converts an ultrasonic echo signal received from a test target into an electrical signal, and the receiver beam former 1202 gathers multiple channels of echo signals (more specifically, digital data into which the echo signals are converted) received from oscillators arranged in an array or matrix form in the transducer 1201.

[0120] The wireless transceiver module 1250 performs procedures necessary for transmitting an echo signal to an ultrasonic imaging apparatus 1280 in the 60 GHz frequency band. The association performing unit 1251 performs a procedure for associating the probe apparatus 1200 using a mmWave-based wireless network. As described above, the mmWave-based wireless network may be a PBSS that follows the WiGig standard of WGA. When the probe 1200 and the ultrasonic imaging apparatus 1280 perform communications via the PBSS, the ultrasonic imaging apparatus 1280 may operate as a PCP instead of the probe 1200, in order that the size and weight of the probe 1200 can be kept low by not including the components therein which would be necessary to allow the probe to be a PCP.

[0121] The frame generation unit 1252 generates a data frame with a format suitable for the mmWave-based wireless network, by using the echo signal received via the transducer 1201.

[0122] The wireless communication unit 1256 transmits the data frame generated by the frame generation unit 1252 to the ultrasonic imaging apparatus 1280 via the 60 GHz frequency band.

[0123] The beam forming unit 1255 performs mmWave beamforming together with the ultrasonic imaging apparatus 1280. In other words, the beam forming unit 1255 performs procedures necessary for efficiently transmitting and receiving data to and from the ultrasonic imaging apparatus 1280 by using mmWaves, such as by using sector level sweeping and beam refinement techniques, well known to those of ordinary skill in the art.

[0124] The link formation unit 1260 forms a link with the ultrasonic imaging apparatus 1280. When a user command for making a pairing request is received via the user interface 1203, the beacon monitoring unit 1263 receives a mmWave beacon of the PBSS to which the ultrasonic imaging apparatus 1280 belongs. The recep-

tion of the user command for making a pairing request denotes not only physical reception but also requests an operation of parsing and analyzing a received beacon frame.

[0125] Accordingly, the peer determination unit 1262 detects the ultrasonic imaging apparatus 1280 which is to be paired with the probe 1200 by using first pairing information included in the mmWave beacon. The first pairing information represents that the ultrasonic imaging apparatus 1280 has been requested by a user to perform pairing, and may include the MAC address of the ultrasonic imaging apparatus 1280 and PBC information representing that a PBC-type pairing button included in the ultrasonic imaging apparatus 1280 has been pressed.

[0126] The pairing request unit 1261 transmits second pairing information representing that the probe 1200 requests pairing, to the ultrasonic imaging apparatus 1280 via the PBSS. The second pairing information may include the MAC address of the probe 1200 and PBC information representing that a PBC-type pairing button included in the probe 1200 has been pressed.

[0127] The margin information processing unit 1253 extracts information about a link margin of a communication link from the ultrasonic imaging apparatus 1280. The link margin information may be included in a link margin response frame that the ultrasonic imaging apparatus 1280 transmits to the probe 1200 in response to a request of the probe 1200 or periodically without requests or when the state of the communication link degrades.

[0128] The margin control unit 1254 controls the link margin based on the link margin response frame. More specifically, the margin control unit 1254 may adjust the link margin by performing at least one of a change in transmission power, a change in a MCS, a change in beam forming, and a change in a channel frequency within the 60 GHz frequency band.

[0129] The above-described method and apparatus embodiments of the present invention can be realized in hardware or as software or computer code that can be stored in a recording medium such as a CD ROM, an RAM, a floppy disk, a hard disk, a DVD or a magneto-optical disk or downloaded over a network, so that the methods described herein can be rendered in such software using a general purpose computer, or a special processor or in programmable or dedicated hardware, such as an ASIC or FPGA. As would be understood in the art, the computer, the processor or the programmable hardware include memory components, e.g., RAM, ROM, Flash, etc. that may store or receive software or computer code that when accessed and executed by the computer, processor or hardware implement the processing methods described herein.

[0130] While the present invention has been particularly shown and described with reference to exemplary embodiments thereof, it will be understood by those of ordinary skill in the art that various changes in form and details may be made therein without departing from the

spirit and scope of the present invention as defined by the following claims and their equivalents.

5 Claims

1. A probe apparatus for ultrasound diagnostic imaging, comprising:

10 an ultrasound transducer, which is arranged to generate at least an echo signal;
a frame generation unit which is arranged to generate a data frame to include in the data frame the echo signal received from the ultrasound transducer;
15 a wireless communication unit which is arranged to transmit the data frame to an ultrasonic imaging apparatus over a signal channel.

20 2. The probe apparatus of claim 1, further comprising an association performing unit which is arranged to perform a procedure for associating the probe apparatus with a mmWave-based wireless network.

25 3. The probe apparatus of claim 1 or 2, wherein the frame generation unit is arranged to generate a data frame with a format suitable for mmWave-based wireless network, and the mmWave-based wireless network is a Personal Basic Service Set (PBSS) that follows the WiGig standard of the Wireless Gigabit Alliance (WGA), and the ultrasonic imaging apparatus is arranged to operate as a PBSS control point (PCP) of the PBSS.

30 4. The probe apparatus of claim 1, 2 or 3, further comprising a beam forming unit which is arranged to perform mmWave beamforming of the signal in the 60 GHz frequency band to transmit the data frame to the ultrasonic imaging apparatus.

35 5. The probe apparatus of any preceding claim, further comprising:

40 a link formation unit which is arranged to form a communication link with the ultrasonic imaging apparatus in a Personal Basic Service Set (PBSS) that uses mmWaves;
a margin information processing unit which is arranged to extract information about a link margin of the communication link from a link margin response frame received from the ultrasonic imaging apparatus; and
45 a margin control unit which is arranged to control the probe apparatus to perform at least one of a change in transmission power of an echo signal, a change in a modulation and coding scheme (MCS) to be applied to the echo signal, a change in beam forming with the ultrasonic
50
55

- imaging apparatus, and a change in channel frequency within a 60 GHz frequency band based on the extracted information received from the margin information processing unit.
6. The ultrasound diagnostic system of claim 5, wherein the margin information processing unit is arranged to transmit a link margin request frame requesting information about the link margin to the ultrasonic imaging apparatus, and to receive and process the link margin response frame received from the ultrasonic imaging apparatus in response to the link margin request frame.
7. A communication method of a probe apparatus for ultrasound diagnostic imaging, the communication method comprising:
- generating an echo signal using a ultrasound transducer;
 - generating a data frame to include in the data frame the echo signal received from the ultrasound transducer of the probe apparatus; and
 - transmitting the data frame to an ultrasonic imaging apparatus over a signal channel.
8. The communication method of claim 7, wherein the generating the data frame comprises generating a data frame with a format suitable for mmWave-based wireless network, and the mmWave-based wireless network is a Personal Basic Service Set (PBSS) that follows the WiGig standard of the Wireless Gigabit Alliance (WGA), and the ultrasonic imaging apparatus operates as a PBSS control point (PCP) of the PBSS, further optionally comprising performing beamforming of a mmWave beacon transmitted to the ultrasonic imaging apparatus.
9. The communication method of claim 7 or 8, further including:
- using the mmWave-based wireless network to form a communication link with the ultrasonic imaging apparatus in a Personal Basic Service Set (PBSS) that uses mmWaves for signal transmission;
 - extracting information about a link margin of the communication link from a link margin response frame received from the ultrasonic imaging apparatus via the communication link; and
 - performing at least one of a change in transmission power of an echo signal, a change in a modulation and coding scheme (MCS) to be applied to the echo signal, a change in beam forming with the ultrasonic imaging apparatus, and a change in channel frequency within a 60 GHz frequency band, based on the extracted information about link margin.
10. The communication method of claim 9, further comprising including the link margin information in a link margin response frame that the ultrasonic imaging apparatus transmits to the probe via the communication link in response to a request of the probe or periodically without requests or when the state of the communication link degrades.
11. An ultrasound diagnostic system comprising: a probe apparatus, having an ultrasound transducer; and an ultrasound imaging apparatus, wherein:
- the probe apparatus is arranged to transmit an echo signal received from the ultrasound transducer of the probe apparatus to the ultrasonic imaging apparatus; and
 - the ultrasonic imaging apparatus is arranged to generate an ultrasonic image based on the echo signal received from the probe apparatus.
12. The ultrasound diagnostic system of claim 11, wherein the ultrasonic imaging apparatus is arranged to generate a data frame with a format suitable for mmWave-based wireless network, and the mmWave-based wireless network is a Personal Basic Service Set (PBSS) that follows the WiGig standard of the Wireless Gigabit Alliance (WGA), and the ultrasonic imaging apparatus operates as a PBSS control point (PCP) of the PBSS, wherein the probe further optionally comprises a beam forming unit arranged for beam forming of a mmWave beacon transmitted to the ultrasonic imaging apparatus.
13. The ultrasound diagnostic system of claim 11 or 12, wherein the probe apparatus comprises:
- a link formation unit, which is arranged to form a communication link with the ultrasonic imaging apparatus in a Personal Basic Service Set (PBSS) that uses mmWaves;
 - a margin information processing unit which is arranged to extract information about a link margin of the communication link from a link margin response frame received from the ultrasonic imaging apparatus; and
 - a margin control unit which is arranged to control the probe apparatus to perform at least one of a change in transmission power of an echo signal, a change in a modulation and coding scheme (MCS) to be applied to the echo signal, a change in beam forming with the ultrasonic imaging apparatus, and a change in channel frequency within a 60 GHz frequency band based on the extracted information received from the margin information processing unit.
14. The ultrasound diagnostic system of claim 13, wherein the margin information processing unit is

arranged to transmit a link margin request frame requesting information about the link margin to the ultrasonic imaging apparatus, and to receive and process a link margin response frame received from the ultrasonic imaging apparatus in response to the transmitted link margin request frame. 5

15. A computer-readable recording medium having embodied thereon a computer program for executing a method according to at least one of claim 7 - 10. 10

15

20

25

30

35

40

45

50

55

【Figure 1】

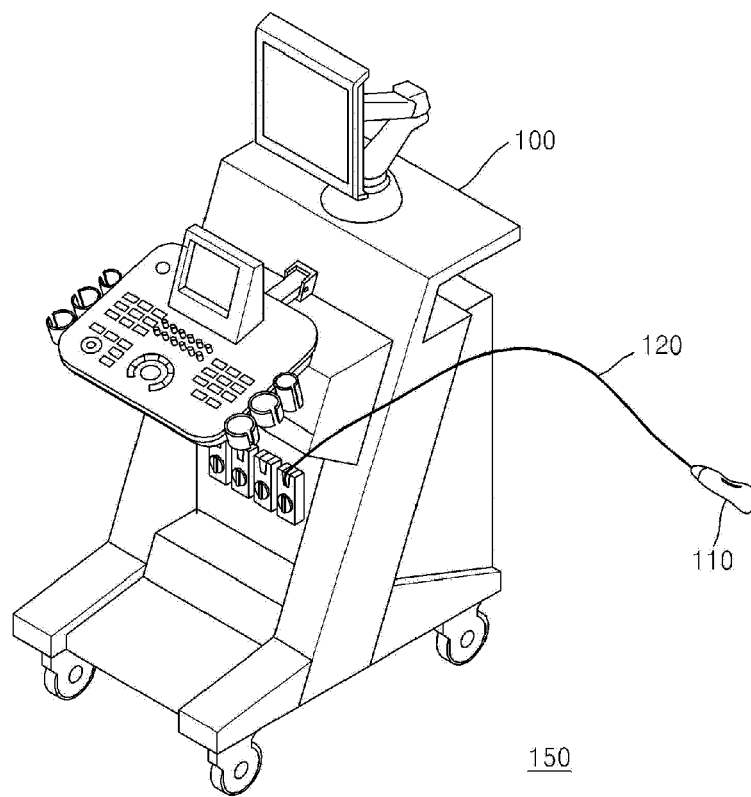

【Figure 2】

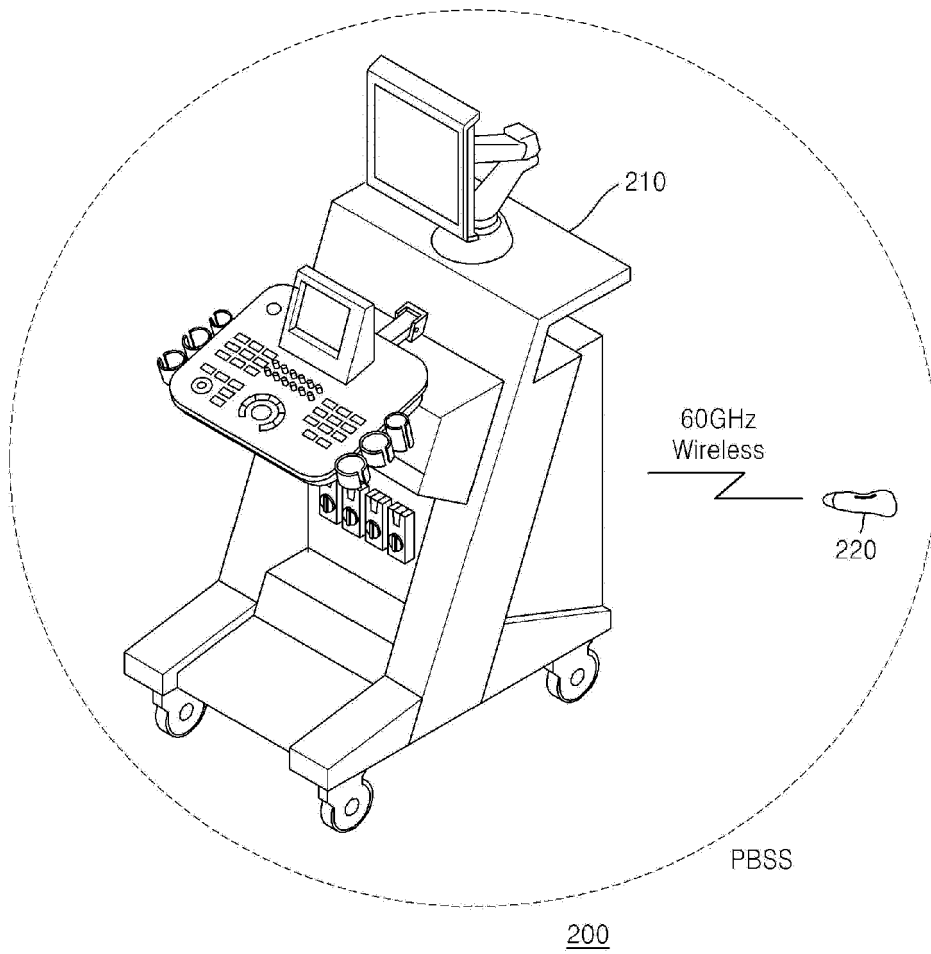

【Figure 3】

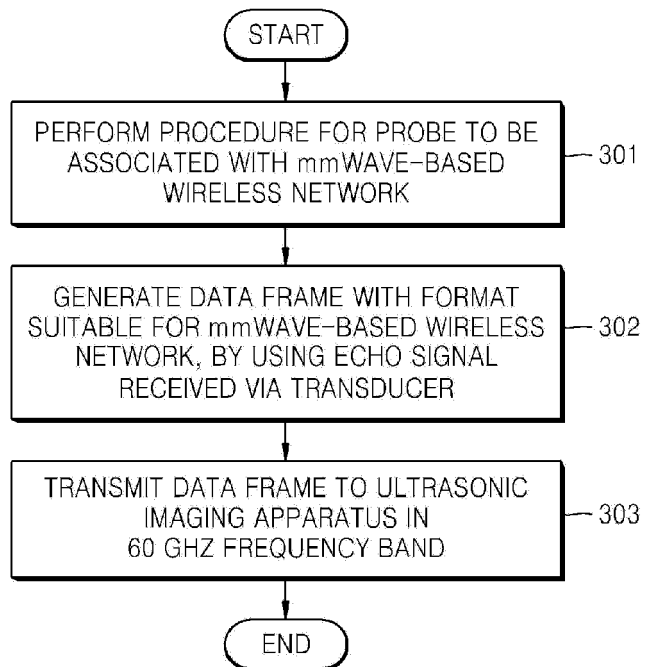

【Figure 4】

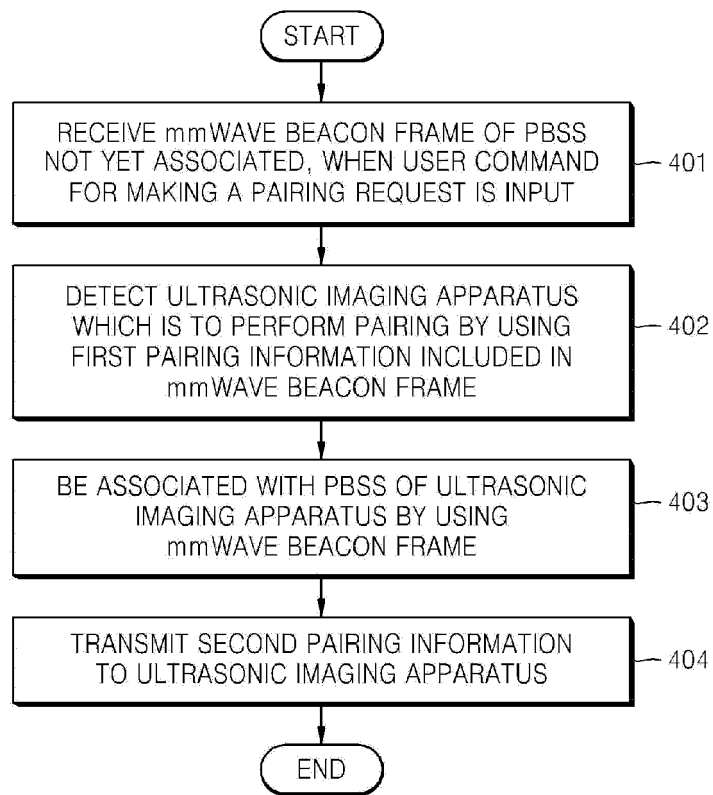

【Figure 5】

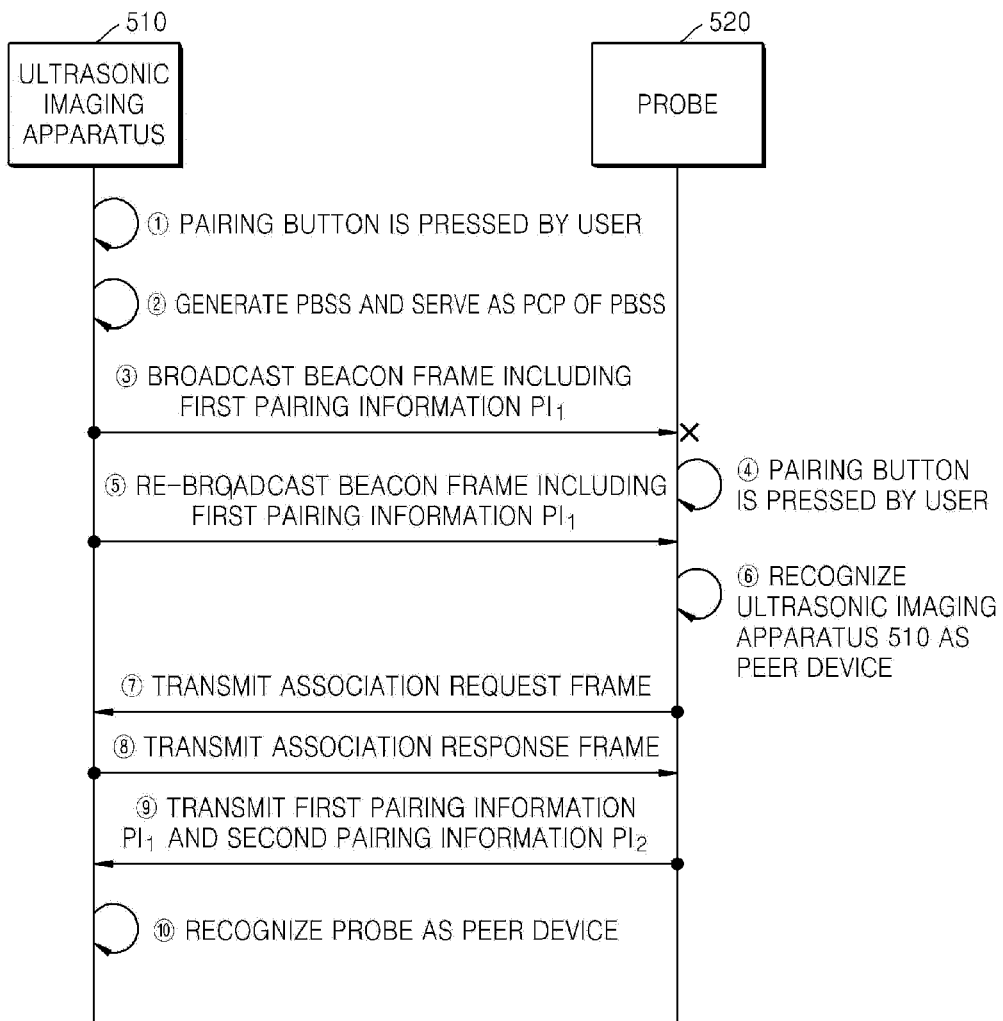

【Figure 6】

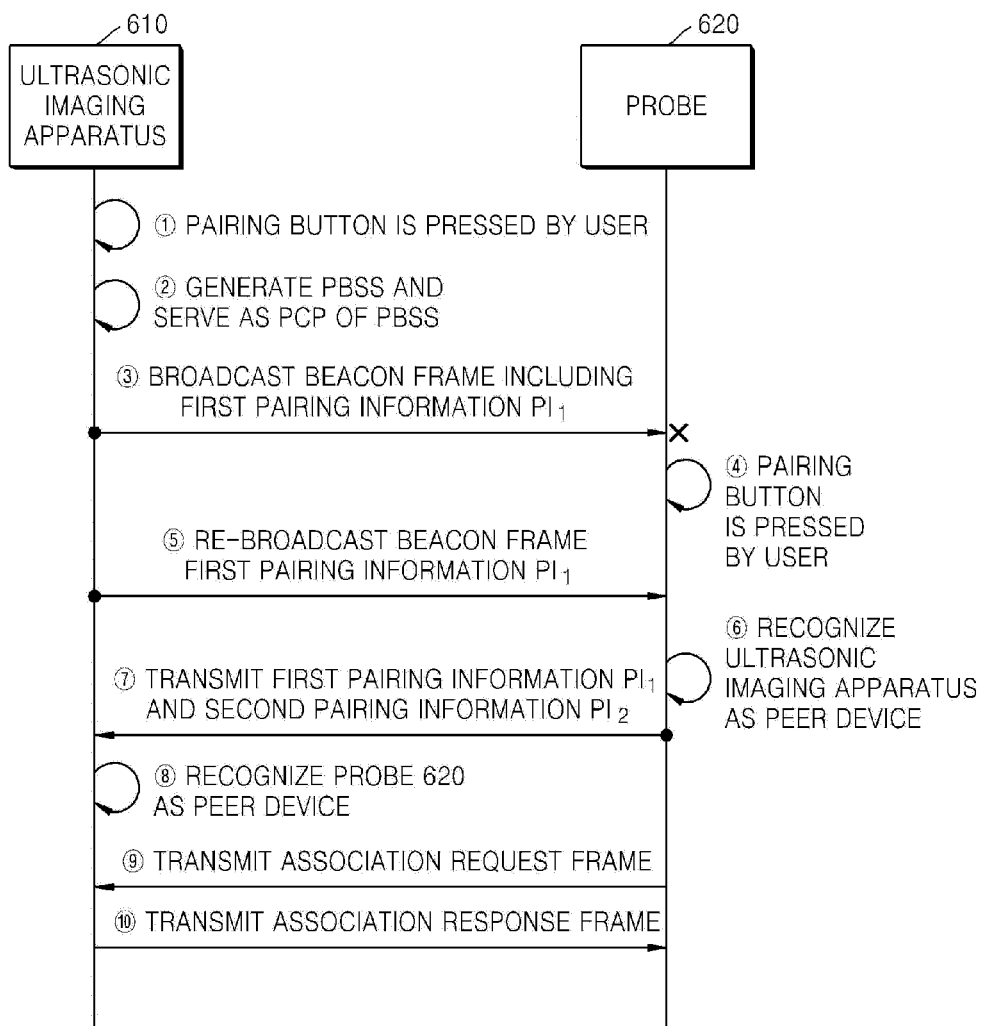

【Figure 7】

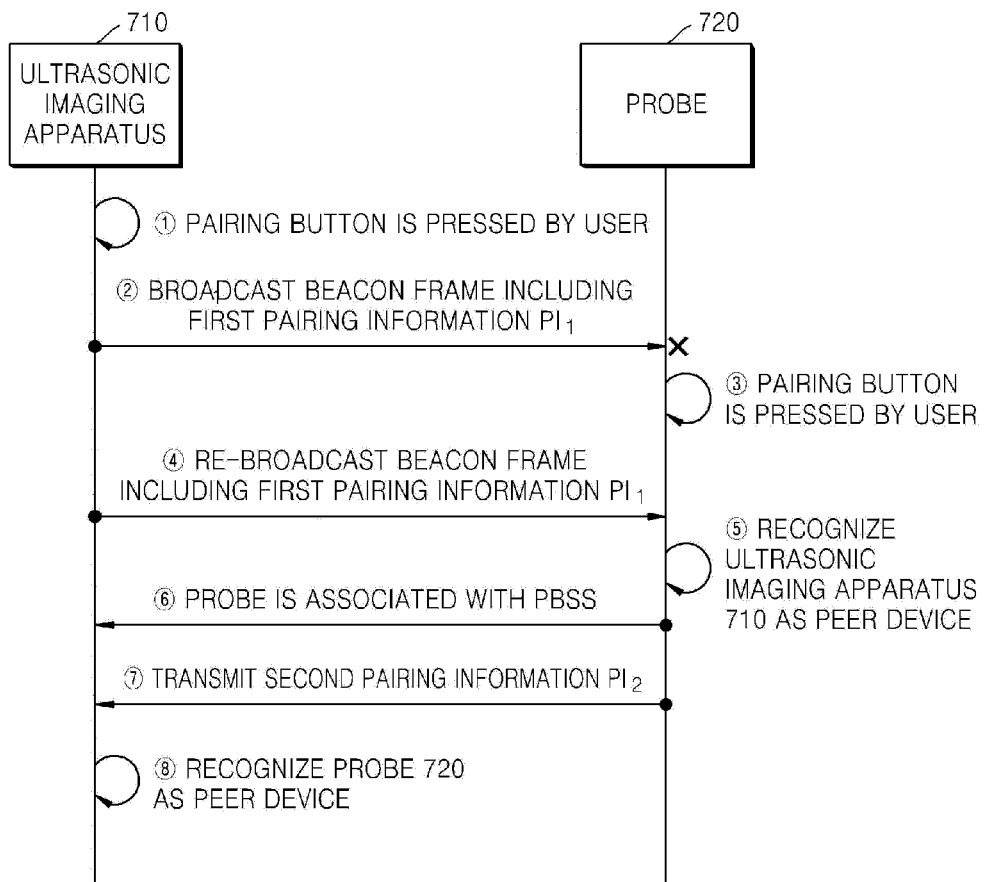

【Figure 8】

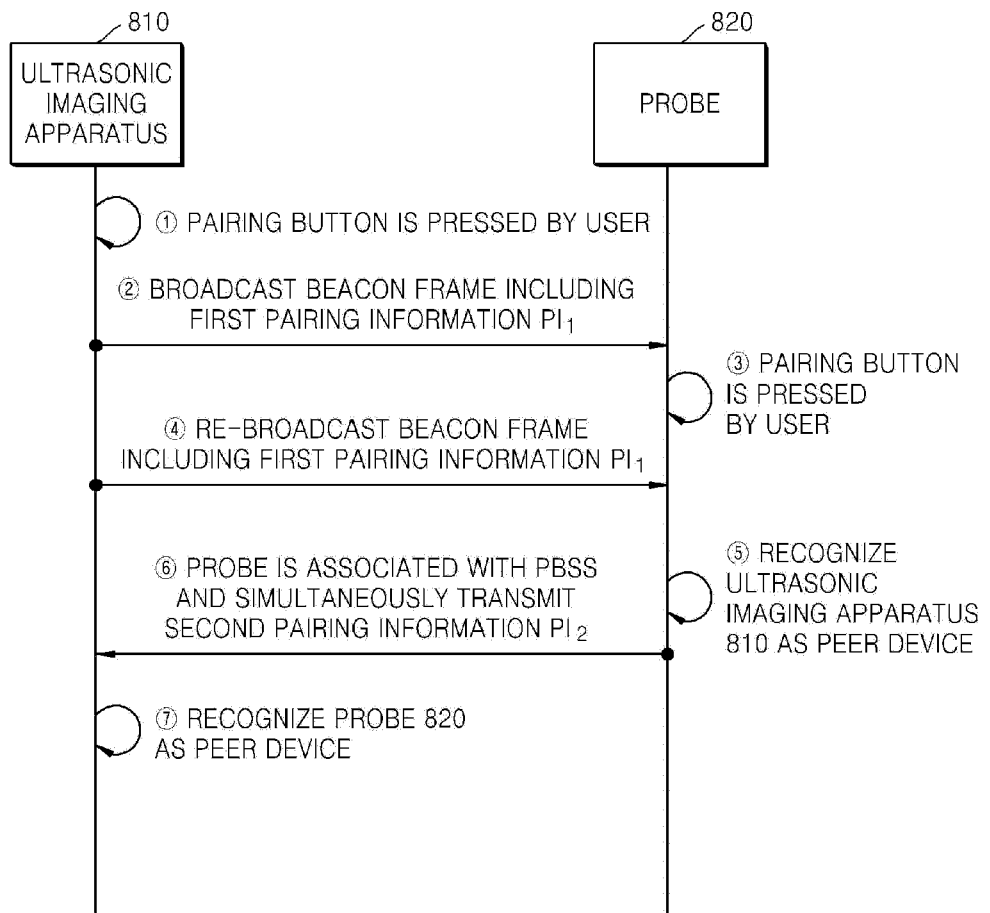

*190

【Figure 9】

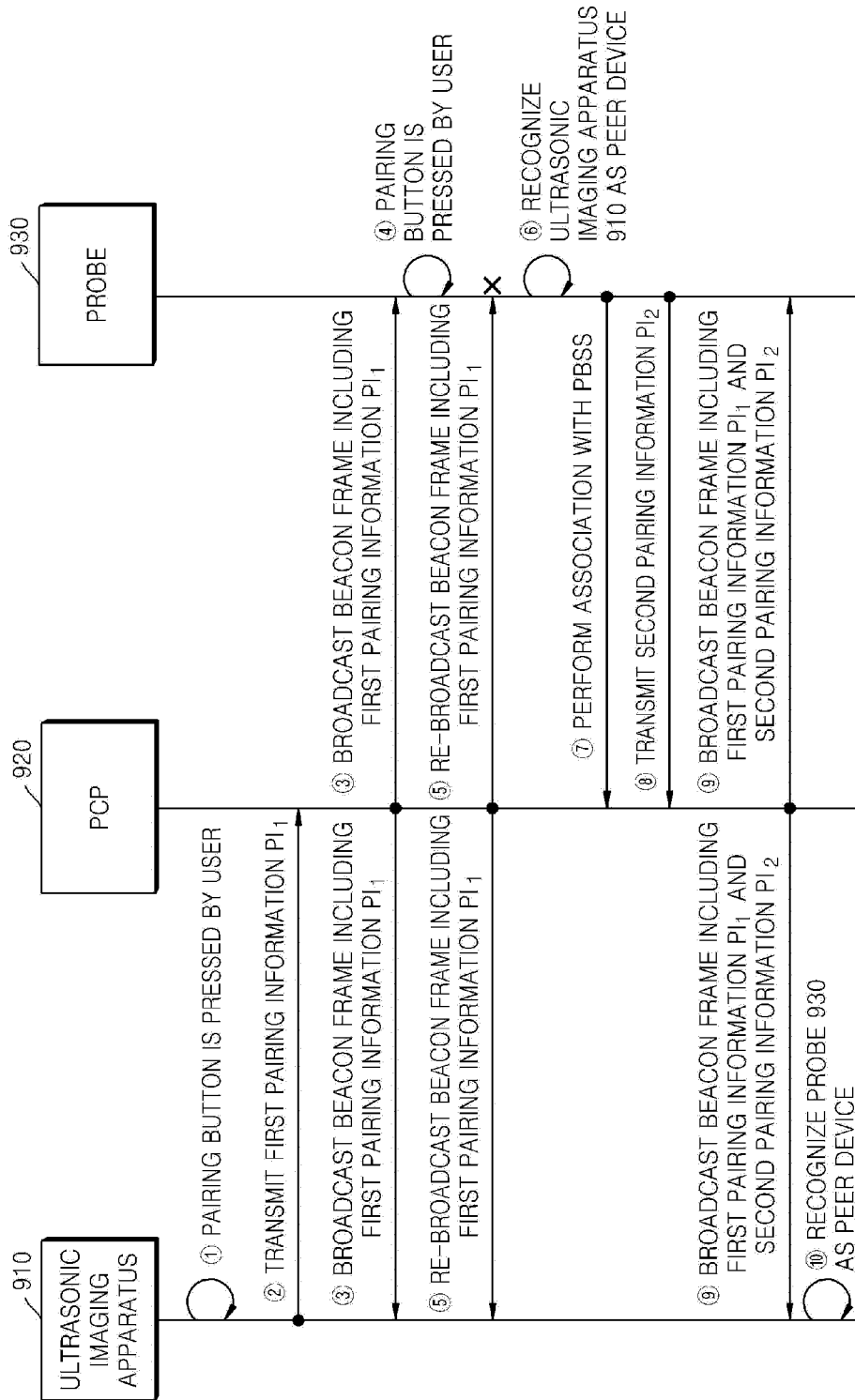

【Figure 10】

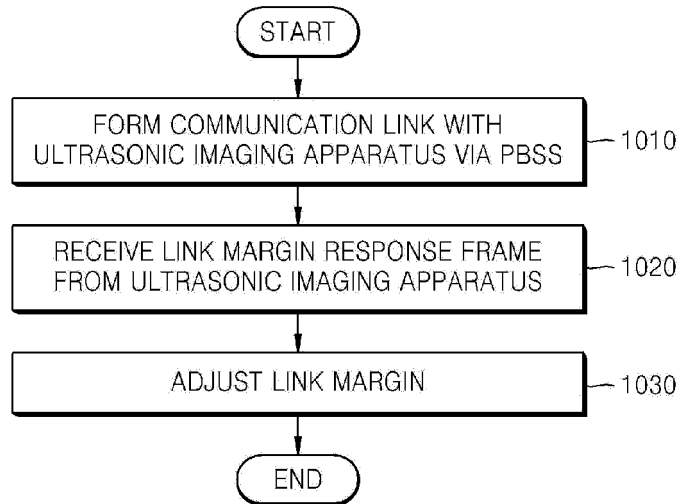

【Figure 11】

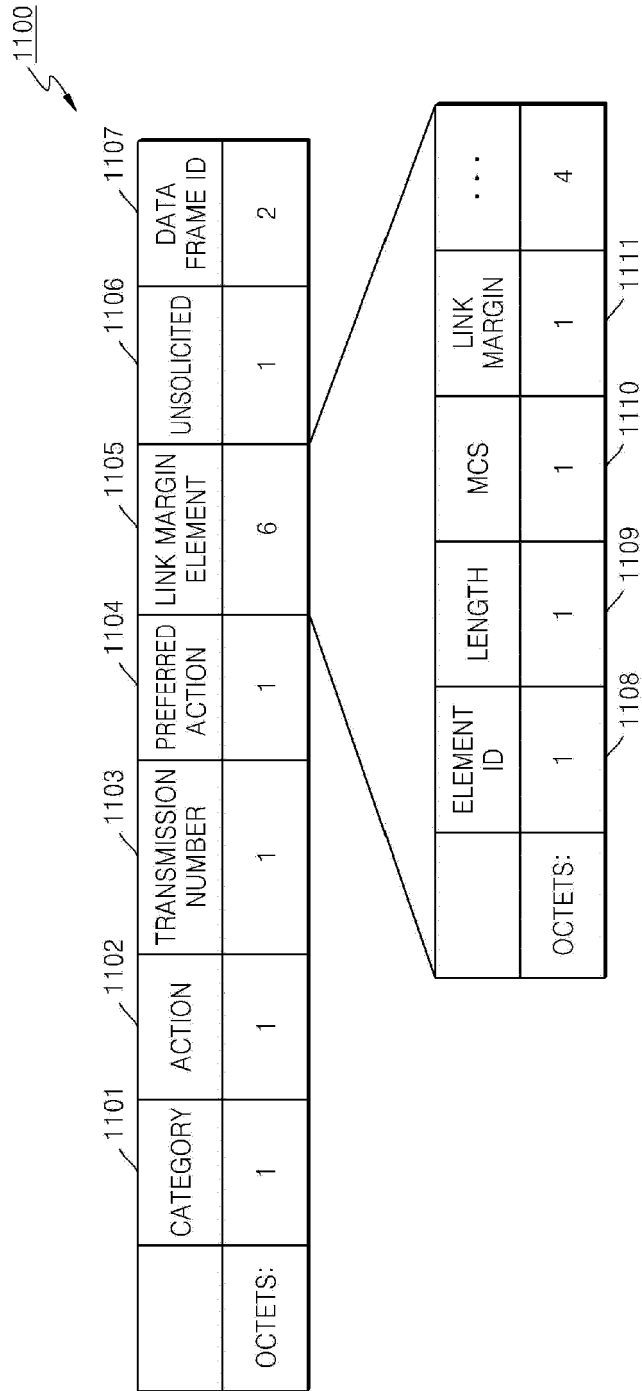

【Figure 12】

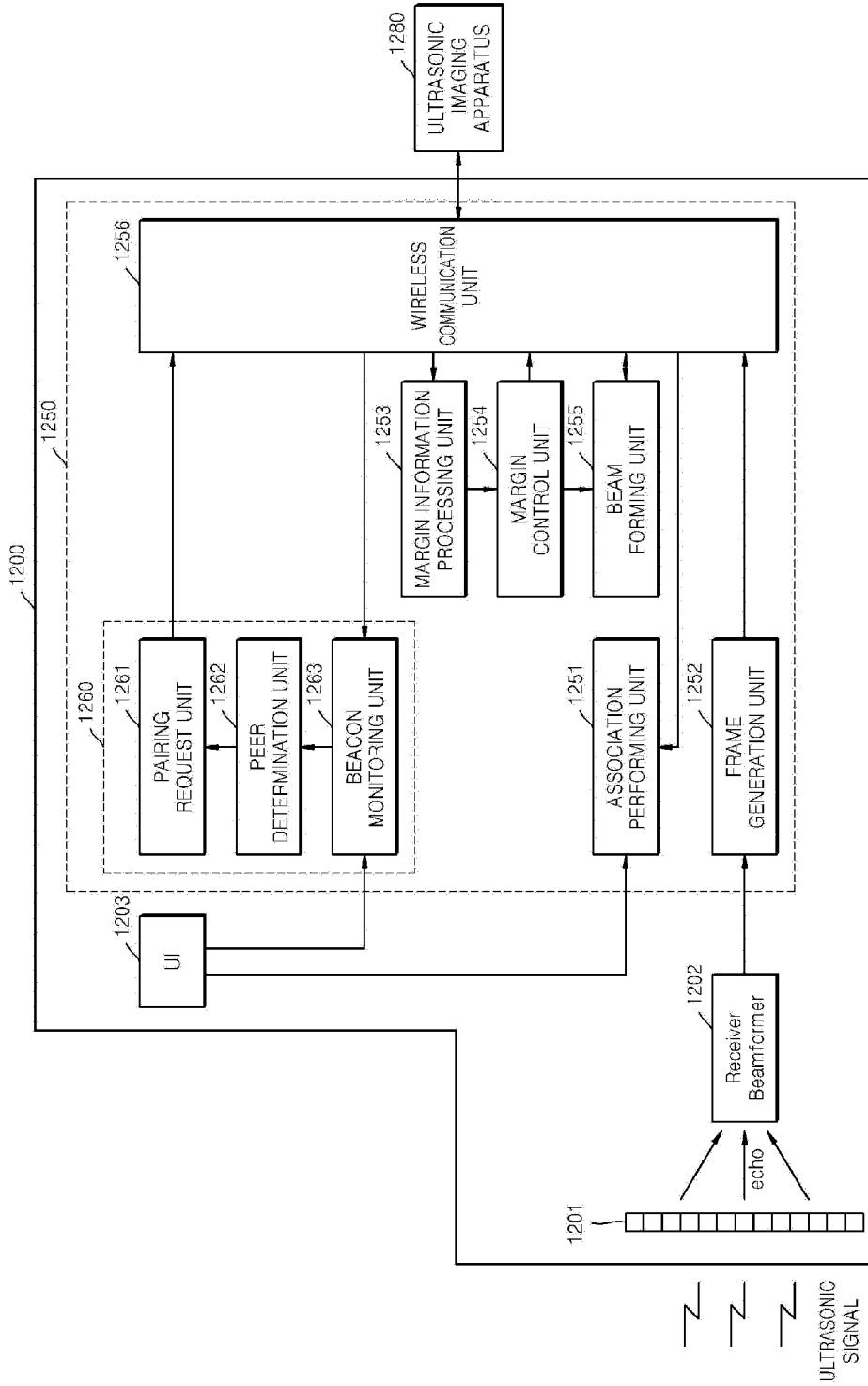



EUROPEAN SEARCH REPORT

Application Number
EP 16 19 6182

5

10

15

20

25

30

35

40

45

50

55

DOCUMENTS CONSIDERED TO BE RELEVANT			
Category	Citation of document with indication, where appropriate, of relevant passages	Relevant to claim	CLASSIFICATION OF THE APPLICATION (IPC)
X	US 2011/105904 A1 (WATANABE YASUHITO [JP]) 5 May 2011 (2011-05-05) * abstract * * paragraph [0067] - paragraph [0123] * * figures 2,5,10 *	1-15	INV. A61B8/00 ADD. H04W84/12
X	US 2010/286527 A1 (CANNON MICHAEL G [US] ET AL) 11 November 2010 (2010-11-11) * abstract * * paragraph [0025] - paragraph [0060] * * figures 1,2 *	1-15	
X	WO 2008/115312 A2 (WORCESTER POLYTECH INST [US]; PEDERSEN PEDER C [US]; SZABO THOMAS L [U] 25 September 2008 (2008-09-25) * abstract * * paragraph [0037] - paragraph [0050] * * figure 1 *	1-15	
X	US 2010/191121 A1 (SATOH YOSHIKI [JP] ET AL) 29 July 2010 (2010-07-29) * abstract * * paragraph [0007] * * paragraph [0014] * * paragraph [0080] - paragraph [0093] * * figures 1-3,5 *	1-15	TECHNICAL FIELDS SEARCHED (IPC) A61B H04W
The present search report has been drawn up for all claims			
Place of search Munich		Date of completion of the search 1 February 2017	Examiner Hodgins, Will
CATEGORY OF CITED DOCUMENTS X : particularly relevant if taken alone Y : particularly relevant if combined with another document of the same category A : technological background O : non-written disclosure P : intermediate document		T : theory or principle underlying the invention E : earlier patent document, but published on, or after the filing date D : document cited in the application L : document cited for other reasons & : member of the same patent family, corresponding document	

EPO FORM 1503 03/02 (P04C01)

ANNEX TO THE EUROPEAN SEARCH REPORT
ON EUROPEAN PATENT APPLICATION NO.

EP 16 19 6182

5

This annex lists the patent family members relating to the patent documents cited in the above-mentioned European search report. The members are as contained in the European Patent Office EDP file on The European Patent Office is in no way liable for these particulars which are merely given for the purpose of information.

01-02-2017

10

15

20

25

30

35

40

45

50

55

Patent document cited in search report	Publication date	Patent family member(s)	Publication date
US 2011105904 A1	05-05-2011	CN 102076264 A	25-05-2011
		EP 2422703 A1	29-02-2012
		JP 5549598 B2	16-07-2014
		US 2011105904 A1	05-05-2011
		WO 2010122791 A1	28-10-2010

US 2010286527 A1	11-11-2010	US 2010286527 A1	11-11-2010
		US 2015293214 A1	15-10-2015

WO 2008115312 A2	25-09-2008	US 2010298711 A1	25-11-2010
		WO 2008115312 A2	25-09-2008

US 2010191121 A1	29-07-2010	NONE	

EPO FORM P0459

For more details about this annex : see Official Journal of the European Patent Office, No. 12/82

专利名称(译)	用于超声诊断的探头的无线通信方法及其设备		
公开(公告)号	EP3143938A1	公开(公告)日	2017-03-22
申请号	EP2016196182	申请日	2012-07-25
[标]申请(专利权)人(译)	三星电子株式会社		
申请(专利权)人(译)	SAMSUNG ELECTRONICS CO. , LTD.		
当前申请(专利权)人(译)	SAMSUNG ELECTRONICS CO. , LTD.		
[标]发明人	KIM KANG SIK KIM JUNG JUN HAN HO SAN HONG SOON JAE		
发明人	KIM, KANG-SIK KIM, JUNG-JUN HAN, HO-SAN HONG, SOON-JAE		
IPC分类号	A61B8/00 H04W84/12		
CPC分类号	A61B8/4405 A61B8/4472 H04W84/12		
优先权	1020110073773 2011-07-25 KR PCT/KR2012/005910 2012-07-25 WO		
其他公开文献	EP3143938B1		
外部链接	Espacenet		

摘要(译)

用于超声诊断成像的探头装置与基于mmWave的个人基本服务装置 (PBSS) 相关联, 执行与超声成像装置的配对, 并且将经由探头的换能器部分接收的回波信号发送到使用超声成像装置的超声成像装置。信号通道在60GHz频带内, 从而不需要数据传输电缆, 大大减少了操作员的不便。

【Figure 2】

