



(12) EUROPEAN PATENT APPLICATION

(43) Date of publication:  
22.02.2006 Bulletin 2006/08

(51) Int Cl.:  
A61B 8/12 (2006.01) B06B 1/06 (2006.01)  
G01S 15/89 (2006.01)

(21) Application number: 05017874.8

(22) Date of filing: 17.08.2005

(84) Designated Contracting States:  
AT BE BG CH CY CZ DE DK EE ES FI FR GB GR  
HU IE IS IT LI LT LU LV MC NL PL PT RO SE SI  
SK TR  
Designated Extension States:  
AL BA HR MK YU

(72) Inventors:  
• Satoh, Yoshiaki  
Ashigarakami-gun  
Kanagawa 258-8538 (JP)  
• Tsujita, Kazuhiro  
Ashigarakami-gun  
Kanagawa 258-8538 (JP)

(30) Priority: 20.08.2004 JP 2004240787

(74) Representative: Klunker . Schmitt-Nilson . Hirsch  
Winzererstrasse 106  
80797 München (DE)

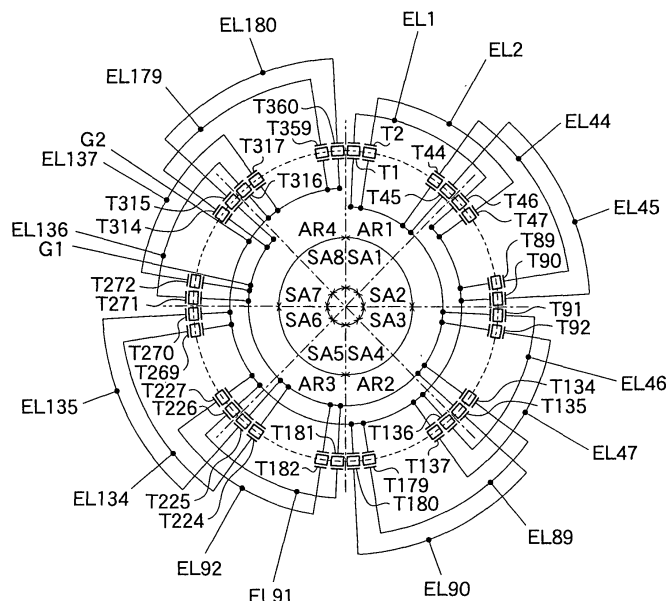
(71) Applicant: FUJI PHOTO FILM CO., LTD.  
Minami-ashigara-shi,  
Kanagawa 250-0193 (JP)

(54) Ultrasonic endoscope and ultrasonic endoscopic apparatus

(57) In an ultrasonic endoscope capable of being inserted into a body of a patient and imaging ultrasonic tomographic images, a frame rate in electronic radial scanning operation is improved. The ultrasonic endoscope includes: an ultrasonic transducer unit (40) including plural ultrasonic transducers (T1 to T360), each having a first electrode and a second electrode, for transmitting and receiving ultrasonic waves; a plurality of first interconnections (EL1 to EL180) each connected to the

first electrodes of predetermined ultrasonic transducers; and a plurality of second interconnections (G1 and G2) each connected to the second electrodes of ultrasonic transducers having the first electrodes not connected to each other; wherein the ultrasonic transducer unit (40) performs scanning operation by simultaneously transmitting the same number of ultrasonic beams in each of plural angle regions when selectively supplied with drive signals via the plurality of first interconnections and the plurality of second interconnections.

FIG.4



## Description

### BACKGROUND OF THE INVENTION

#### Field of the Invention

**[0001]** The present invention relates to an ultrasonic endoscope capable of being inserted into a body of a patient and imaging ultrasonic tomographic images for medical diagnoses and an ultrasonic endoscopic apparatus including such an endoscope.

#### Description of a Related Art

**[0002]** Recent years, an ultrasonic endoscope has been used for medical diagnoses by inserting it into a body of a patient and imaging ultrasonic tomographic images. In such an ultrasonic endoscope, generally, a mechanical radial scanning method of performing scanning with viewing angle of 360° by mechanically rotating an array including plural ultrasonic transducers (ultrasonic vibrators) that transmit and receive ultrasonic waves has been adopted.

**[0003]** However, according to the mechanical radial scanning method, compared to a scanning method of performing scanning with viewing angle of 90° using a convex ultrasonic transducer array in an external ultrasonic imaging apparatus, in the case where conditions of sound ray density, scanning depth, etc. are set into the same condition, there is a problem that scanning time (frame period) for obtaining an image for one frame becomes longer in order to perform scanning with wide viewing angle and the frame rate becomes low.

**[0004]** On the other hand, an electronic radial scanning method of performing scanning with viewing angle of 360° by electronic scanning has been proposed. For example, Kinichi Takeda et al., "The Experience of Electric Radial Endoscopic Ultrasonography on Gastroenterology", Jpn JMed Ultrasonics, Vol. 31, Supplement (2004), 77-C062, pp. 238 discloses results from studies on efficacy and problems of an electronic radial ultrasonic endoscope based on experiences of using the electronic radial ultrasonic endoscope for various digestive system diseases.

**[0005]** Further, Japanese Patent Application Publication JP-A-2-134142 discloses an electronic radial ultrasonic beam apparatus having improved resolving power in which a flexible substrate on which plural ultrasonic vibrators are provided in a line is formed in a cylindrical shape and an interval between ultrasonic vibrators in the joint part of the flexible substrate is set to an integral multiple of an arrangement interval of the respective vibrators. Further, the apparatus includes drive element switching circuits and delay lines for enabling scanning operation at an interval position between the ultrasonic vibrators in the joint part by driving ultrasonic vibrators adjacent to the interval position (page 2, right upper column, line 14 to left lower column, line 3; page 4, right

lower column, lines 2-10; and Fig. 3).

**[0006]** However, in the ultrasonic endoscope according to the electronic radial scanning method, in order to obtain a B-mode ultrasonic tomographic image with viewing angle of 360°, it is also required to sequentially transmit ultrasonic beams (sound rays) SL1 to SL360 in a frame period T as shown in Fig. 11A while varying the positions of ultrasonic transducers to be used along a circumferential direction as shown in Fig. 11B. Accordingly, compared to the case of performing scanning operation with viewing angle of 90° using a convex ultrasonic transducer array, the frame period T becomes about four times and the frame rate is reduced to about one-quarter.

**[0007]** Further, in the electronic radial ultrasonic endoscope, in the case where bloodstream information is obtained by the Doppler method, in order to improve the S/N ratio of minute bloodstream information, plural pulses are sequentially transmitted in the same direction. For example, as shown in Fig. 11D, four ultrasonic beams SL1-1 to SL1-4 are sequentially transmitted in the first direction, and the transmission is repeated while varying the transmission direction, and finally, four ultrasonic beams SL360-1 to SL360-4 are sequentially transmitted in the 360th direction. In this case, compared to the case of imaging the B-mode tomographic image as shown in Figs. 11A and 11B, the frame period T becomes about four times (4T) and the frame rate is reduced to about one-quarter as shown in Fig. 11C.

### SUMMARY OF THE INVENTION

**[0008]** The present invention is achieved in view of the above-mentioned problems. An object of the present invention is to improve a frame rate in electronic radial scanning operation in an ultrasonic endoscope capable of being inserted into a body of a patient and imaging ultrasonic tomographic images.

**[0009]** In order to solve the above-mentioned problems, an ultrasonic endoscope according to one aspect of the present invention comprises: an ultrasonic transducer unit including plural ultrasonic transducers, each having a first electrode and a second electrode, for transmitting and receiving ultrasonic waves; a plurality of first interconnections each connected to the first electrodes of respective ones of the plural ultrasonic transducers; and a plurality of second interconnections each connected to the second electrodes of respective ones of the plural ultrasonic transducers having the first electrodes not connected to each other; wherein the ultrasonic transducer unit performs scanning operation by simultaneously transmitting the same number of ultrasonic beams in each of plural angle regions formed by dividing a scanning angle region by a predetermined angle when selectively supplied with drive signals via the plurality of first interconnections and the plurality of second interconnections.

**[0010]** Further, an ultrasonic endoscopic apparatus

according to a first aspect of the present invention comprises: an ultrasonic endoscope having an ultrasonic transducer unit including plural ultrasonic transducers, each having a first electrode and a second electrode, for transmitting and receiving ultrasonic waves; and an ultrasonic observation apparatus for selectively supplying drive signals to the ultrasonic transducer unit such that the ultrasonic transducer unit performs scanning operation by simultaneously transmitting the same number of ultrasonic beams in each of plural angle regions formed by dividing a scanning angle region by a predetermined angle.

**[0011]** Furthermore, an ultrasonic endoscopic apparatus according to a second aspect of the present invention comprises: an ultrasonic endoscope having an ultrasonic transducer unit including plural ultrasonic transducers, each having a first electrode and a second electrode, for transmitting and receiving ultrasonic waves, a plurality of first interconnections each connected to the first electrodes of respective ones of the plural ultrasonic transducers, and a plurality of second interconnections each connected to the second electrodes of respective one of the plural ultrasonic transducers having the first electrodes not connected to each other; transmitting means for generating drive signals and supplying the drive signals to the ultrasonic transducer unit via the plurality of first interconnections; plural pieces of switch means connected to the plurality of second interconnections and a fixed potential; and control means for controlling the transmitting means such that scanning operation is performed by simultaneously transmitting the same number of ultrasonic beams in each of plural angle regions formed by dividing a scanning angle region by a predetermined angle and supplying control signals for controlling whether each of the plurality of second interconnections is connected to the fixed potential or not to the plural pieces of switch means.

**[0012]** According to the present invention, the frame rate can be improved by simultaneously transmitting the same number of ultrasonic beams at a certain angle interval in each of plural angle regions formed by dividing a scanning angle region by a predetermined angle. Further, in the case where the angle interval of the simultaneously transmitted ultrasonic beams is set to 90°, an influence of crosstalk between plural ultrasonic beams is reduced and image quality of ultrasonic tomographic images can be uniformized. Furthermore, the number of interconnections between the ultrasonic transducer unit and the main body (ultrasonic observation apparatus) is reduced, and thereby, the ultrasonic endoscope can be downsized while the cost is reduced.

#### BRIEF DESCRIPTION OF THE DRAWINGS

##### **[0013]**

Fig. 1 is a block diagram showing a constitution of an ultrasonic endoscope apparatus 1 according to

one embodiment of the present invention; Fig. 2 shows a structure of an ultrasonic endoscope 2 shown in Fig. 1;

Fig. 3 is an enlarged view showing a tip of the ultrasonic endoscope 2 shown in Fig. 2;

Fig. 4 shows a constitution of an ultrasonic transducer unit 40 shown in Fig. 2;

Figs. 5A to 5E are charts for explanation of a frame rate when the ultrasonic endoscope 2 shown in Fig. 1 is driven in B-mode;

Figs. 6A to 6E are charts for explanation of a frame rate when the ultrasonic endoscope 2 shown in Fig. 1 is driven in Doppler mode with frame rate priority;

Figs. 7A to 7E are charts for explanation of a frame rate when the ultrasonic endoscope 2 shown in Fig. 1 is driven in Doppler mode with sensitivity priority;

Fig. 8 is a diagram for explanation of steering operation at boundaries between sub regions;

Fig. 9 shows an example of combination of frame rate and sensitivity;

Fig. 10 shows a slide switch for selection of one of combinations of frame rate and sensitivity; and

Figs. 11A to 11D are charts for explanation of frame rates in a conventional ultrasonic endoscope.

#### DESCRIPTION OF THE PREFERRED EMBODIMENTS

**[0014]** Hereinafter, preferred embodiments of the present invention will be described in detail by referring to the drawings. The same reference numbers will be assigned to the same component elements and the description thereof will be omitted.

**[0015]** As shown in Fig. 1, an ultrasonic endoscope apparatus 1 according to one embodiment of the present invention includes an electronic radial ultrasonic endoscope 2, an ultrasonic observation apparatus 3 to which the ultrasonic endoscope 2 is connectable, a display device 4 connected to the ultrasonic observation apparatus 3.

**[0016]** The ultrasonic observation apparatus 3 includes a console 11, a CPU (central processing unit) 12, first and second switches SW1 and SW2, a transmitting circuit 14, a receiving circuit 15, a B-mode processing unit 16, a Doppler processing unit 17, a digital scan converter (DSC) 18, an image memory 19, and a digital/analog converter (D/A converter) 20.

**[0017]** As shown in Fig. 2, the ultrasonic endoscope 2 includes an insertion part 31, an operation part 32, a connecting cord 33, and a universal cord 34.

**[0018]** The insertion part 31 of the ultrasonic endoscope 2 has an elongated flexible tubular shape so as to be inserted into a body of a patient. The operation part 32 is provided at the base end of the insertion part 31, connected to the ultrasonic observation apparatus 3 via the connecting cord 33 and connected to a light source device (not shown) via the universal cord 34.

**[0019]** In the insertion part 31 of the ultrasonic endoscope 2, an illumination window and an observation win-

dow are provided. An illumination lens for outputting illumination light supplied via a light guide from the light source device is attached to the illumination window. These form an illumination optical system. Further, an objective lens is attached to the observation window, and, in a position where the objective lens forms an image, an input end of an image guide or solid-state image sensor such as a CCD camera is disposed. These form an observation optical system.

**[0020]** Fig. 3 is an enlarged view showing the tip of the ultrasonic endoscope 2 shown in Fig. 2. At the tip of the insertion part 31 of the ultrasonic endoscope 2, an ultrasonic transducer unit 40 in which plural ultrasonic transducers are arranged on the circumference thereof. The ultrasonic transducer unit 40 transmits an ultrasonic beam according to drive signals supplied from the transmitting circuit 14 of the ultrasonic observation apparatus 3, receives ultrasonic echoes reflected from a target part or the like, and outputs plural reception signals to the receiving circuit 15 of the ultrasonic observation apparatus 3. Further, at the tip of the insertion part 31 of the ultrasonic endoscope 2, a hole is formed from which a treatment tool or the like inserted from a treatment tool insertion hole 35 provided in the operation part 32 is protruded.

**[0021]** As shown in Fig. 4, the ultrasonic transducer unit 40 is formed by arranging 360 ultrasonic transducers T1 to T360 on the circumference thereof. Here, the ultrasonic transducers T1 to T360 are grouped as below, in order to divide a scanning angle region with viewing angle of  $360^\circ$  into four divisional regions (first to fourth divisional regions AR1 to AR4) by  $90^\circ$ , perform radial scanning by transmitting four ultrasonic beams with the same timing in the first to fourth divisional regions AR1 to AR4, respectively, and holding the intervals of the four ultrasonic beams transmitted with the same timing at  $90^\circ$ .

**[0022]** The first group of ultrasonic transducers consists of 45 ultrasonic transducers T1 to T45 that belong to a first sub region SA1 of two sub regions (first and second sub regions SA1 and SA2) formed by dividing the first divisional region AR1 shown in Fig. 4 by  $45^\circ$ . Accordingly, the range of scanning by the ultrasonic transducers T1 to T45 in the first group corresponds to the range of the first sub region SA1.

**[0023]** The second group of ultrasonic transducers consists of 45 ultrasonic transducers T46 to T90 that belong to the above-mentioned second sub region SA2. Accordingly, the range of scanning by the ultrasonic transducers T46 to T90 in the second group corresponds to the range of the second sub region SA2.

**[0024]** The third group of ultrasonic transducers consists of 45 ultrasonic transducers T91 to T135 that belong to a third sub region SA3 of two sub regions (third and fourth sub regions SA3 and SA4) formed by dividing the second divisional region AR2 shown in Fig. 4 by  $45^\circ$ . Accordingly, the range of scanning by the ultrasonic transducers T91 to T135 in the third group corresponds to the range of the third sub region SA3.

**[0025]** The fourth group of ultrasonic transducers consists of 45 ultrasonic transducers T136 to T180 that belong to the above-mentioned fourth sub region SA4. Accordingly, the range of scanning by the ultrasonic transducers T136 to T180 in the fourth group corresponds to the range of the fourth sub region SA4.

**[0026]** The fifth group of ultrasonic transducers consists of 45 ultrasonic transducers T181 to T225 that belong to a fifth sub region SA5 of two sub regions (fifth and sixth sub regions SA5 and SA6) formed by dividing the third divisional region AR3 shown in Fig. 4 by  $45^\circ$ . Accordingly, the range of scanning by the ultrasonic transducers T181 to T225 in the fifth group corresponds to the range of the fifth sub region SA5.

**[0027]** The sixth group of ultrasonic transducers consists of 45 ultrasonic transducers T226 to T270 that belong to the above-mentioned sixth sub region SA6. Accordingly, the range of scanning by the ultrasonic transducers T226 to T270 in the sixth group corresponds to the range of the sixth sub region SA6.

**[0028]** The seventh group of ultrasonic transducers consists of 45 ultrasonic transducers T271 to T315 that belong to a seventh sub region SA7 of two sub regions (seventh and eighth sub regions SA7 and SA8) formed by dividing the fourth divisional region AR4 shown in Fig. 4 by  $45^\circ$ . Accordingly, the range of scanning by the ultrasonic transducers T271 to T315 in the seventh group corresponds to the range of the seventh sub region SA7.

**[0029]** The eighth group of ultrasonic transducers consists of 45 ultrasonic transducers T316 to T360 that belong to the above-mentioned eighth sub region SA8. Accordingly, the range of scanning by the ultrasonic transducers T316 to T360 in the eighth group corresponds to the range of the eighth sub region SA8.

**[0030]** Each of the ultrasonic transducers T1 to T360 includes an ultrasonic vibrator formed by sandwiching a piezoelectric element of PZT, PVDF, or the like between an individual electrode and a common electrode. When a drive signal is applied to the individual electrode while the common electrode is connected to a fixed potential (for example, ground potential in the embodiment), the transducer transmits ultrasonic waves, and receives ultrasonic echoes reflected from a target part or the like and generates a reception signal in the individual electrode.

**[0031]** As shown in Fig. 4, in each of the first to fourth divisional regions AR1 to AR2, the individual electrodes of the two ultrasonic transducers located at  $45^\circ$  interval with respect to the circumferential direction of the ultrasonic transducer unit 40 are electrically connected to the same one of signal interconnections EL1 to EL 180.

**[0032]** For example, in the first divisional region AR1, the individual electrode of the ultrasonic transducer T1 within the first group and the individual electrode of the ultrasonic transducer T46 within the second group located at  $45^\circ$  interval with respect to the circumferential direction of the ultrasonic transducer unit 40 are electrically connected to the signal interconnection EL1. Similarly,

the individual electrode of the ultrasonic transducer T2 within the first group and the individual electrode of the ultrasonic transducer T47 within the second group located at 45° interval with respect to the circumferential direction of the ultrasonic transducer unit 40 are electrically connected to the signal interconnection EL2.

**[0033]** Further, in the second divisional region AR2, the individual electrode of the ultrasonic transducer T91 within the third group and the individual electrode of the ultrasonic transducer T136 within the fourth group located at 45° interval with respect to the circumferential direction of the ultrasonic transducer unit 40 are electrically connected to the signal interconnection EL46. Similarly, the individual electrode of the ultrasonic transducer T92 within the third group and the individual electrode of the ultrasonic transducer T137 within the fourth group located at 45° interval with respect to the circumferential direction of the ultrasonic transducer unit 40 are electrically connected to the signal interconnection EL47.

**[0034]** On the other hand, the common electrodes of the ultrasonic transducers of the same group are electrically connected to the same one of the common electrode interconnections G1 and G2, and the common electrodes of the ultrasonic transducers of the plural groups located at each 90° interval with respect to the circumferential direction of the ultrasonic transducer unit 40 are also electrically connected to the same one of the common electrode interconnections G1 and G2.

**[0035]** That is, the common electrodes of the ultrasonic transducers T1 to T45, T91 to T135, T181 to T225, and T271 to T315 of the odd number (the first, third, fifth, and seventh) groups located at each 90° interval with respect to the circumferential direction of the ultrasonic transducer unit 40 are electrically connected to the common electrode interconnection G1. Further, the common electrodes of the ultrasonic transducers T46 to T90, T136 to T180, T226 to T270, and T316 to T380 of the even number (the second, fourth, sixth, and eighth) groups located at each 90° interval with respect to the circumferential direction of the ultrasonic transducer unit 40 are electrically connected to the common electrode interconnection G2.

**[0036]** Since the individual electrodes and the common electrodes of the ultrasonic transducers T1 to T360 are thus interconnected, and then, the number of interconnections becomes "182" as the sum of "180" as the number of signal interconnections EL1 to EL180, and "2" as the number of common electrode interconnections G1 and G2. Consequently, the number of interconnections can be reduced to the half of the number of interconnections "361" (= 360 + 1) in the case where signal interconnections are provided to the individual electrodes of the ultrasonic transducers T1 to T360, respectively, and one common electrode interconnection is wired to the common electrodes.

**[0037]** The signal interconnections EL1 to EL180 are connected to the transmitting circuit 14 and the receiving circuit 15 of the ultrasonic observation apparatus 3 shown

in Fig. 1 via the connecting cord 33 shown in Fig. 2, and the common electrode interconnections G1 and G2 are connected to the first and second switches SW1 and SW2 of the ultrasonic observation apparatus 3 via the connecting cord 23.

**[0038]** The console 11 of the ultrasonic observation apparatus 3 shown in Fig. 1 outputs control signal A for controlling start/stop of ultrasonic imaging operation in the ultrasonic endoscope 2 and mode selection (B-mode or Doppler mode, and frame rate priority mode or sensitivity priority mode) to the CPU 12 according to the operation of an operator.

**[0039]** The CPU 12 generates first and second switch control signals B1 and B2 for controlling ON/OFF of the first and second switches SW1 and SW2 based on the control signal A input from the console 11 and outputs those signals to the first and second switches SW1 and SW2, respectively. Further, the CPU 12 outputs transmitting circuit control signal A1 for controlling the operation of the transmitting circuit 14 to the transmitting circuit 14, and outputs receiving circuit control signal A2 for controlling the operation of the receiving circuit 15 to the receiving circuit 15.

**[0040]** The first and second switches SW1 and SW2 are turned ON/OFF according to the first and second switch control signals B1 and B2 input from the CPU 12. When the first and second switches SW1 and SW2 are turned ON, the common electrode interconnections G1 and G2 are grounded, respectively, and, when the first and second switches SW1 and SW2 are turned OFF, the common electrode interconnections G1 and G2 are opened, respectively. Since the ultrasonic transducer is operated only when the common electrode is grounded, the ultrasonic transducers T1 to T360 can be operated separately in the odd number (the first, third, fifth, and seventh) groups and the even number (the second, fourth, sixth, and eighth) groups.

**[0041]** The transmitting circuit 14 generates drive signals based on the transmitting circuit control signal A1, and outputs these drive signals to the signal interconnections EL1 to EL 180. According to these drive signals, ultrasonic waves are transmitted from the ultrasonic transducers of groups with the grounded common electrodes.

**[0042]** On the other hand, the receiving circuit 15 amplifies the reception signals input from the ultrasonic transducers of groups with the grounded common electrodes via the signal interconnections EL1 to EL 180 at a predetermined amplification degree, and then, converts the amplified reception signals into digital reception signals by performing A/D conversion. Further, the receiving circuit 15 performs reception focus processing by performing processing of phase matching or the like on the digital reception signals to form sound ray data in which focal points of the ultrasonic echoes are narrowed.

**[0043]** The B-mode processing unit 16 performs correction of attenuation depending on the distance according to the depth of the reflection position of ultrasonic

waves on the sound ray data formed by the receiving circuit 15 and performs envelope detection processing thereon to generate B-mode image data.

**[0044]** The Doppler processing unit 17 removes high frequency components from the reception signals that have been subjected to the reception focus processing based on the sound ray data formed by the receiving circuit 15, and performs orthogonal phase detection processing on the reception signals. Further, the Doppler processing unit 17 removes unwanted clutter components caused by the variations in specular echoes of blood vessel wall, heart wall, or the like from the reception signals that have been subjected to orthogonal phase detection. Thus, Doppler image data formed by extracting only reflection components from bloodstream is generated.

**[0045]** Since the B-mode image data generated in the B-mode processing unit 16 and the Doppler image data generated in the Doppler processing unit 17 have been obtained by the scanning method different from the normal scanning method of television signal, the DSC 18 converts (raster conversion) the data into normal image data. The image memory 19 stores the image data generated in the DSC 18. The D/A converter 20 converts the digital image data read from the image memory 19 into analog image signals and outputs them to the display unit 4. Thereby, in the display unit 4, an ultrasonic tomographic image imaged by the ultrasonic endoscope 2 is displayed.

**[0046]** Next, an operation of the ultrasonic endoscopic apparatus 1 according to the embodiment will be described.

**[0047]** In the case where an ultrasonic tomographic image is imaged using the ultrasonic endoscope 2 shown in Fig. 2, the operator emits light from the light source connected to one end of the universal cord 34 and outputs illumination light into the body of the patient from the illumination window provided at the tip of the insertion part 31, and inserts the insertion part 31 of the ultrasonic endoscope 2 into the body of the patient while observing the insertion state from the observation window.

**[0048]** First, the operation of the ultrasonic endoscopic apparatus in the case of imaging a B-mode image will be described. When the insertion part 31 reaches a target position, the operator allows the console 11 to output the control signal A for starting the operation of the ultrasonic endoscope 2 and designating B-mode to the CPU 12 by operating the console 11 (Fig. 1).

**[0049]** The CPU 12 outputs the transmitting circuit control signal A1 for instructing start of the operation of the transmitting circuit 14 and generation of the drive signals for B-mode to the transmitting circuit 14. Further, the CPU 12 outputs the receiving circuit control signal A2 for instructing start of the operation of the receiving circuit 15 to the receiving circuit 15.

**[0050]** Furthermore, the CPU 12 outputs the first switch control signal B1 for turning ON the first switch SW1 to the first switch SW1. When the first switch SW1

is turned ON, the common electrode interconnection G1 is grounded and the common electrodes of the ultrasonic transducers T1 to T45, T91 to T135, T181 to T225, and T271 to T315 of the odd number (the first, third, fifth, and seventh) groups shown in Fig. 4 are grounded.

**[0051]** The transmitting circuit 14 generates drive signals (pulse signals in the embodiment) to be respectively supplied to the individual electrodes of the ultrasonic transducers T1 to T45, T91 to T135, T181 to T225, and T271 to T315 of the odd number (the first, third, fifth, and seventh) groups via the signal interconnections EL1 to EL180. Simultaneously, the transmitting circuit 14 generates those drive signals such that four ultrasonic beams are transmitted from points separated at 90° from each other using three ultrasonic transducers for forming each one ultrasonic beam.

**[0052]** For example, when scanning for one frame is started as shown in Fig. 5A, first, drive pulse signals for driving the ultrasonic transducers are generated as shown in Figs. 5B to 5E such that the ultrasonic beam (sound ray) SL1 (Fig. 5B) is transmitted from the ultrasonic transducers T1 to T3 within the first group in the divisional region AR1, the ultrasonic beam SL91 (Fig. 5C) is transmitted from the ultrasonic transducers T91 to T93 within the third group in the divisional region AR2, the ultrasonic beam SL181 (Fig. 5D) is transmitted from the ultrasonic transducers T181 to T183 within the fifth group in the divisional region AR3, and the ultrasonic beam SL271 (Fig. 5E) is transmitted from the ultrasonic transducers T271 to T273 within the seventh group in the divisional region AR4.

**[0053]** The plural reception signals obtained by receiving ultrasonic echoes generated by the reflection of these ultrasonic beams from the object are output to the receiving circuit 15 via the signal interconnections EL1 to EL180 and sound ray data is formed and B-mode image data is generated in the B-mode processing unit 16, and then, the data is raster-converted in the DSC 18 and image data is formed. The image data is stored in the image memory 19.

**[0054]** When the scanning by the ultrasonic transducers T1 to T45, T91 to T135, T181 to T225, and T271 to T315 of the odd number (the first, third, fifth, and seventh) groups is finished, the CPU 12 outputs the first switch control signal B1 for turning OFF the first switch SW1 to the first switch SW1 and outputs the second switch control signal B2 for turning ON the second switch SW2 to the second switch SW2. Thereby, the common electrode interconnection G2 is grounded and the common electrodes of the ultrasonic transducers T46 to T90, T136 to T180, T226 to T270, and T316 to T380 of the even number (the second, fourth, sixth, and eighth) groups are grounded.

**[0055]** The transmitting circuit 14 generates plural drive pulse signals to be supplied to the individual electrodes of the ultrasonic transducers T46 to T90, T136 to T180, T226 to T270, and T316 to T380 of the even number (the second, fourth, sixth, and eighth) groups via

the signal interconnections EL1 to EL 180, respectively, as is the case for the ultrasonic transducers of the odd number groups.

**[0056]** The plural reception signals obtained by receiving ultrasonic echoes generated by the reflection of these ultrasonic beams from the object are output to the receiving circuit 15 via the signal interconnections EL1 to EL 180 and sound ray data is formed and B-mode image data is generated in the B-mode processing unit 16, and then, the data is raster-converted in the DSC 18 and image data is formed. The image data is stored in the image memory 19.

**[0057]** Thus, by alternately driving the ultrasonic transducers of the odd number and even number groups and convex-scanning the respective divisional regions, the scanning angle range of total 360° of viewing angle is radially scanned. By the way, the scanning angle range is not limited to 360° but may be set to 180° or other values. The image data read from the image memory 19 is converted into analog image signals by the D/A converter 20 and output to the display device 4. Thereby, a B-mode ultrasonic tomographic image is displayed on the display device 4.

**[0058]** By the ultrasonic endoscopic apparatus according to the embodiment, since the ultrasonic beams are transmitted in four directions with the same timing, in the B-mode, compared to the frame period T shown in Fig. 11A in the conventional case where the ultrasonic beam is transmitted one by one, the frame period can be reduced to one-quarter (e.g., T/4) as shown in Fig. 5A and the frame rate can be increased to four times. Further, since the angular interval between the four ultrasonic beams transmitted with the same timing is 90°, the crosstalk due to simultaneous transmission of plural ultrasonic beams may hardly occur.

**[0059]** However, since the ultrasonic transducers in the adjacent sub regions can not be used for transmitting ultrasonic beams near the boundaries of the sub regions SA1 to SA8 (e.g., around the time of switching of groups of ultrasonic transducers by the first and second switches SW1 and SW2), irregularities in ultrasonic beams are caused.

**[0060]** Accordingly, for example, after the ultrasonic beam SL45 is transmitted, by controlling the delay amounts of the drive pulse signals to be supplied to the individual electrodes of the ultrasonic transducers T43, T44, and T45 within the first group, which have been used for transmission of the ultrasonic beam SL45, so as to steer the ultrasonic beam (sector scan), the ultrasonic beam SL45' is transmitted toward the second sub region SA2 side than the ultrasonic beam SL45 as shown in Fig. 8.

**[0061]** Then, before the ultrasonic beam SL46 is transmitted using the ultrasonic transducers T46, T47, and T48 within the second group, by controlling the delay amounts of the drive pulse signals to be supplied to the individual electrodes of these ultrasonic transducers T46, T47, and T48 so as to steer the ultrasonic beam (sector

scan), the ultrasonic beam SL46' is transmitted toward the first sub region SA1 side than the ultrasonic beam SL46 as shown in Fig. 8. Thereby, irregularities in the ultrasonic beams at the boundary between the first sub region SA1 and the second sub region SA2 can be reduced.

**[0062]** Further, also at the boundary between the third and fourth sub regions SA3 and SA4, at the boundary between the fifth and sixth sub regions SA5 and SA6, and, at the boundary between the seventh and eighth sub regions SA7 and SA8, when steering the ultrasonic beam SL45', by simultaneously steering the ultrasonic beams SL135', SL225', SL315' (sector scan), and, when steering the ultrasonic beam SL46', by simultaneously steering the ultrasonic beams SL136', SL226', SL316' (sector scan), the reduction in frame rate due to increase in the number of ultrasonic beams is prevented.

**[0063]** Next, an operation of the ultrasonic endoscopic apparatus in the case where a Doppler mode image is imaged with frame rate priority will be described. The operator operates the console 11 (Fig. 1) to start the operation of the ultrasonic endoscope 2 and allows the console 11 to output the control signal A for instructing the Doppler mode with frame rate priority to the CPU 12.

**[0064]** The CPU 12 outputs the transmitting circuit control signal A1 for instructing start of the operation of the transmitting circuit 14 and generation of the drive signals for Doppler mode to the transmitting circuit 14. Further, the CPU 12 outputs the receiving circuit control signal A2 for instructing start of the operation of the receiving circuit 15 to the receiving circuit 15. In the Doppler mode with frame rate priority, the transmitting circuit 14 generates drive pulse signals such that four ultrasonic beams (pulses) are continuously transmitted at four times in four directions, respectively.

**[0065]** For example, when scanning for one frame is started as shown in Fig. 6A, first, drive pulse signals for driving the ultrasonic transducers are generated as shown in Figs. 6B to 6E such that the continuous four ultrasonic beams (sound rays) SL1-1 to SL1-4 (Fig. 6B) are transmitted from the ultrasonic transducers T1 to T3 within the first group in the divisional region AR1, the continuous four ultrasonic beams SL91-1 to SL91-4 (Fig. 6C) are transmitted from the ultrasonic transducers T91 to T93 within the third group in the divisional region AR2, the continuous four ultrasonic beams SL181-1 to SL181-4 (Fig. 6D) are transmitted from the ultrasonic transducers T181 to T183 within the fifth group in the divisional region AR3, and the continuous four ultrasonic beams SL271-1 to SL271-4 (Fig. 6E) are transmitted from the ultrasonic transducers T271 to T273 within the seventh group in the divisional region AR4.

**[0066]** The plural reception signals obtained by receiving ultrasonic echoes generated by the reflection of these ultrasonic beams from the object are output to the receiving circuit 15 via the signal interconnections EL1 to EL 180 and sound ray data is formed and Doppler mode image data is generated in the Doppler mode processing

unit 17, and then, the data is raster-converted in the DSC 18 and image data is formed. The image data is stored in the image memory 19.

**[0067]** Thus, by convex-scanning the respective divisional regions, the entire scanning angle range is radial-scanned. Furthermore, as well as in the first embodiment, the ultrasonic beam is steered (sector scan) near the boundaries of the sub regions SA1 to SA8. Further, the image data stored in the image memory 19 is read, converted into analog image signals by the D/A converter 20, and output to the display device 4. Thereby, a Doppler image with frame rate priority is displayed in the display device 4.

**[0068]** According to the Doppler mode with frame rate priority, since the operation that four ultrasonic beams are transmitted in four directions are repeated at four times, compared to the frame period 4T shown in Fig. 11B in the conventional case where one ultrasonic beam is transmitted continuously at four times, the frame period can be reduced to one-quarter (e.g., T) as shown in Fig. 6A and the frame rate can be increased to four times.

**[0069]** By the way, in the case where bloodstream information at the location where the pounding of the heart is heavy, the Doppler mode with frame rate priority in which the number of repeated times for repeatedly transmitting the ultrasonic beam in the same direction is reduced is preferable, while, in the case where bloodstream information at the location where the blood flow rate is small, the Doppler mode with sensitivity priority in which the number of repeated times for repeatedly transmitting the ultrasonic beam in the same direction is increased is preferable.

**[0070]** In the case where a Doppler image is imaged in the Doppler mode with sensitivity priority, the operator operates the console 11 (Fig. 1) to start the operation of the ultrasonic endoscope 2 and allows the console 11 to output the control signal A for instructing the Doppler mode with sensitivity priority to the CPU 12.

**[0071]** The CPU 12 outputs the transmitting circuit control signal A1 for instructing start of the operation of the transmitting circuit 14 and generation of the drive signals for Doppler mode with sensitivity priority to the transmitting circuit 14. Further, the CPU 12 outputs the receiving circuit control signal A2 for instructing start of the operation of the receiving circuit 15 to the receiving circuit 15. In the Doppler mode with sensitivity priority, the transmitting circuit 14 generates drive pulse signals such that four ultrasonic beams (pulses) are continuously transmitted at 16 times in four directions, respectively.

**[0072]** For example, when scanning for one frame is started as shown in Fig. 7A, first, drive pulse signals for driving the ultrasonic transducers are generated as shown in Figs. 7B to 7E such that the continuous 16 ultrasonic beams (sound rays) SL1-1 to SL1-16 (Fig. 7B) are transmitted from the ultrasonic transducers T1 to T3 within the first group in the divisional region AR1, the continuous 16 ultrasonic beams SL91-1 to SL91-16 (Fig. 7C) are transmitted from the ultrasonic transducers T91

to T93 within the third group in the divisional region AR2, the continuous four ultrasonic beams SL181-1 to SL181-16 (Fig. 7D) are transmitted from the ultrasonic transducers T181 to T183 within the fifth group in the divisional region AR3, and the continuous four ultrasonic beams SL271-1 to SL271-16 (Fig. 7E) are transmitted from the ultrasonic transducers T271 to T273 within the seventh group in the divisional region AR4.

**[0073]** Then, by the same operation as in the above-mentioned Doppler mode with frame rate priority, a Doppler image with more improved sensitivity than in the case of frame rate priority is displayed in the display apparatus 4.

**[0074]** According to the Doppler mode with sensitivity priority, since the operation that four ultrasonic beams are transmitted in four directions are repeated at 16 times, compared to the frame period 16T in the conventional case where the operation that one ultrasonic beam is transmitted is repeated at 16 times, the frame period can be reduced to one-quarter (e.g., 4T) as shown in Fig. 7A and the frame rate can be increased to four times.

**[0075]** With respect to the frame rate priority and sensitivity priority in the Doppler mode, for example, a slide switch 50 as shown in Fig. 10 may be provided in the console 11 in Fig. 1 for the operator to select one of 14 combinations of sensitivity  $s$  and frame rate  $f$  ( $= 1/T$ ) as shown in Fig. 9. Thereby, the operator can finely select sensitivity  $s$  and frame rate  $f$  as usage and the user-friendliness is improved.

**[0076]** In the above-mentioned embodiments, radial scan has been performed while transmitting the ultrasonic beams with the same timing one by one in the first to fourth divisional regions AR1 to AR4, however, radial scan may be performed while transmitting the plural ultrasonic beams in the respective divisional regions.

**[0077]** Further, the scanning angle region of  $360^\circ$  has been divided into four divisional regions at each  $90^\circ$ , however, the angle at which the scanning angle region is divided may be not  $90^\circ$ . For example, the scanning angle region of  $360^\circ$  may be divided into two divisional regions at each  $180^\circ$ , and radial scan may be performed while transmitting a predetermined number of ultrasonic beams with the same timing in the respective divisional regions.

**[0078]** Furthermore, the respective first to fourth divisional regions AR1 to AR4 have been divided into sub regions SA1 to SA8 at each  $45^\circ$  and the ultrasonic transducers have been grouped with respect to each of the sub regions SA1 to SA8, however, the angle at which the respective divisional regions are divided into sub regions may be not  $45^\circ$ .

**[0079]** For example, the ultrasonic transducers may be grouped in 12 by dividing the respective first to fourth divisional regions AR1 to AR4 into sub regions SA1 to SA12 at each  $30^\circ$ . In this case, the number of signal interconnections is 120 and the individual electrodes of the three ultrasonic transducers separated at each  $30^\circ$  of the plural ultrasonic transducers are electrically connected

to the same signal interconnection in the respective first to fourth divisional regions AR1 to AR4.

**[0080]** Further, in the case, the number of common electrode interconnections G is three, and the common electrodes of the ultrasonic transducers in the same group are electrically connected to the same common electrode interconnection, and the common electrodes of the ultrasonic transducers in the plural groups located at 90° intervals with respect to the circumferential direction of the ultrasonic transducer unit 40 are electrically connected to the same common electrode interconnection. Accordingly, three switches are provided in the ultrasonic observation apparatus 3 shown in Fig. 1, and one of the three switches is turned ON according to three switch control signals supplied from the CPU 12.

**[0081]** In the above embodiments, electronic radial ultrasonic endoscope has been described, however, the present invention can be applied to a convex ultrasonic endoscope in which 180 ultrasonic transducers are arranged in a semicircular form by dividing the region of 180° as a scanning full angle is divided into two divisional regions at each 90°, and performing scanning by transmitting ultrasonic beams one by one with the same timing in the respective divisional regions.

**[0082]** Further, the first and second switches SW1 and SW2 shown in Fig. 1 have been provided in the ultrasonic observation apparatus 3, however, they may be provided in the ultrasonic endoscope 2.

**[0083]** Furthermore, the control signal A for controlling the start/stop of the ultrasonic imaging operation in the ultrasonic endoscope 2 and indicating the mode has been output from the console 11, however, for example, a button for generating the control signal A may be provided in the operation part 32 of the ultrasonic endoscope 2 and the control signal A may be output from the operation part 32 to the CPU 12.

## Claims

### 1. An ultrasonic endoscope comprising:

an ultrasonic transducer unit (40) including plural ultrasonic transducers (T1 to T360), each having a first electrode and a second electrode, for transmitting and receiving ultrasonic waves; a plurality of first interconnections (EL1 to EL180) each connected to the first electrodes of respective ones of said plural ultrasonic transducers; and a plurality of second interconnections (G1 and G2) each connected to the second electrodes of respective ones of said plural ultrasonic transducers having the first electrodes not connected to each other;

wherein said ultrasonic transducer unit (40) performs scanning operation by simultaneously transmitting a

same number of ultrasonic beams in each of plural angle regions formed by dividing a scanning angle region by a predetermined angle when selectively supplied with drive signals via said plurality of first interconnections (EL1 to EL180) and said plurality of second interconnections (G1 and G2).

### 2. An ultrasonic endoscope according to claim 1, wherein:

each of said plurality of first interconnections (EL1 to EL180) is connected, when each of said plural angle regions is divided into plural sub regions (SA1 to SA8) by a second predetermined angle, to the first electrodes of respective ones of said plural ultrasonic transducers located at every second predetermined angle in said plural sub regions; and said plurality of second interconnections (G1 and G2) are connected, when said plural ultrasonic transducers are grouped for said plural sub regions, to the second electrodes of respective ones of said plural ultrasonic transducers included in groups located at every predetermined angle.

### 3. An ultrasonic endoscope according to claim 1, wherein:

said predetermined angle is 90°; and said ultrasonic transducer unit (40) performs scanning operation by simultaneously transmitting plural ultrasonic beams at an angle interval of 90° when selectively supplied with drive signals via said plurality of first interconnections (EL1 to EL180) and said plurality of second interconnections (G1 and G2).

### 4. An ultrasonic endoscopic apparatus comprising:

an ultrasonic endoscope (2) having an ultrasonic transducer unit (40) including plural ultrasonic transducers (T1 to T360), each having a first electrode and a second electrode, for transmitting and receiving ultrasonic waves; and an ultrasonic observation apparatus (3) for selectively supplying drive signals to said ultrasonic transducer unit such that said ultrasonic transducer unit performs scanning operation by simultaneously transmitting a same number of ultrasonic beams in each of plural angle regions formed by dividing a scanning angle region by a predetermined angle.

### 5. An ultrasonic endoscopic apparatus according to claim 4, wherein said ultrasonic observation apparatus (3) selectively supplies drive signals to said ultrasonic transducer unit (40) such that said ultra-

sonic transducer unit performs together first scanning for selectively driving said plural ultrasonic transducers (T1 to T360) and second scanning operation for steering an ultrasonic beam formed by ultrasonic waves transmitted from a predetermined number of ultrasonic transducers in each of plural angle regions formed by dividing a scanning angle region with a predetermined angle.

6. An ultrasonic endoscopic apparatus according to claim 5, wherein said ultrasonic observation apparatus (3) selectively supplies drive signals to said ultrasonic transducer unit (40) such that said ultrasonic transducer unit performs together first scanning operation for selectively driving said plural ultrasonic transducers (T1 to T360) and second scanning operation for steering an ultrasonic beam formed by ultrasonic waves transmitted from a predetermined number of ultrasonic transducers in regions in which said first scanning operation is impossible.

7. An ultrasonic endoscopic apparatus comprising:

an ultrasonic endoscope (2) having an ultrasonic transducer unit (40) including plural ultrasonic transducers (T1 to T360), each having a first electrode and a second electrode, for transmitting and receiving ultrasonic waves, a plurality of first interconnections (EL1 to EL180) each connected to the first electrodes of respective ones of said plural ultrasonic transducers, and a plurality of second interconnections (G1 and G2) each connected to the second electrodes of respective ones of said plural ultrasonic transducers having the first electrodes not connected to each other;

transmitting means (14) for generating drive signals and supplying the drive signals to said ultrasonic transducer unit via said plurality of first interconnections;

plural pieces of switch means (SW1 and SW2) connected to said plurality of second interconnections (G1 and G2) and a fixed potential; and

control means (12) for controlling said transmitting means such that scanning operation is performed by simultaneously transmitting a same number of ultrasonic beams in each of plural angle regions formed by dividing a scanning angle region by a predetermined angle and supplying control signals for controlling whether each of said plurality of second interconnections (G1 and G2) is connected to the fixed potential or not to said plural pieces of switch means.

8. An ultrasonic endoscopic apparatus according to claim 7, wherein:

each of said plurality of first interconnections (EL1 to EL180) is connected when each of said plural angle regions is divided into plural sub regions (SA1 to SA8) by a second predetermined angle, to the first electrodes of respective ones of said plural ultrasonic transducers located at every second predetermined angle in said plural sub regions; and

said plurality of second interconnections (G1 and G2) are connected, when said plural ultrasonic transducers are grouped for said plural sub regions, to the second electrodes of respective ones of said plural ultrasonic transducers included in groups located at every predetermined angle.

9. An ultrasonic endoscopic apparatus according to claim 8, wherein:

said predetermined angle is 90°; and

said ultrasonic transducer unit (40) performs scanning operation by simultaneously transmitting plural ultrasonic beams at an interval of 90° when selectively supplied with drive signals via said plurality of first interconnections (EL1 to EL180) and said plurality of second interconnections (G1 and G2).

10. An ultrasonic endoscopic apparatus according to claim 4, further comprising:

mode switching means (11) for switching, in a Doppler mode in which plural ultrasonic pulses are continuously transmitted in each transmission direction, between a frame rate priority mode in which a number of continuous ultrasonic pulses are reduced within a predetermined range to increase a frame rate and a sensitivity priority mode in which the number of continuous ultrasonic pulses is larger than that in the frame rate priority mode to increase sensitivity.

11. An ultrasonic endoscopic apparatus according to claim 7, further comprising:

mode switching means (11) for switching, in a Doppler mode in which plural ultrasonic pulses are continuously transmitted in each transmission direction, between a frame rate priority mode in which a number of continuous ultrasonic pulses are reduced within a predetermined range to increase a frame rate and a sensitivity priority mode in which the number of continuous ultrasonic pulses is larger than that in the frame rate priority mode to increase sensitivity.

12. An ultrasonic endoscopic apparatus according to claim 7, wherein said plural pieces of switch means

(SW1 and SW2) are provided within said ultrasonic endoscope (2).

13. An ultrasonic endoscopic apparatus according to claim 10, wherein said mode switching means (11) is provided within said ultrasonic endoscope (2). 5
14. An ultrasonic endoscopic apparatus according to claim 11, wherein said mode switching means (11) is provided within said ultrasonic endoscope (2). 10

15

20

25

30

35

40

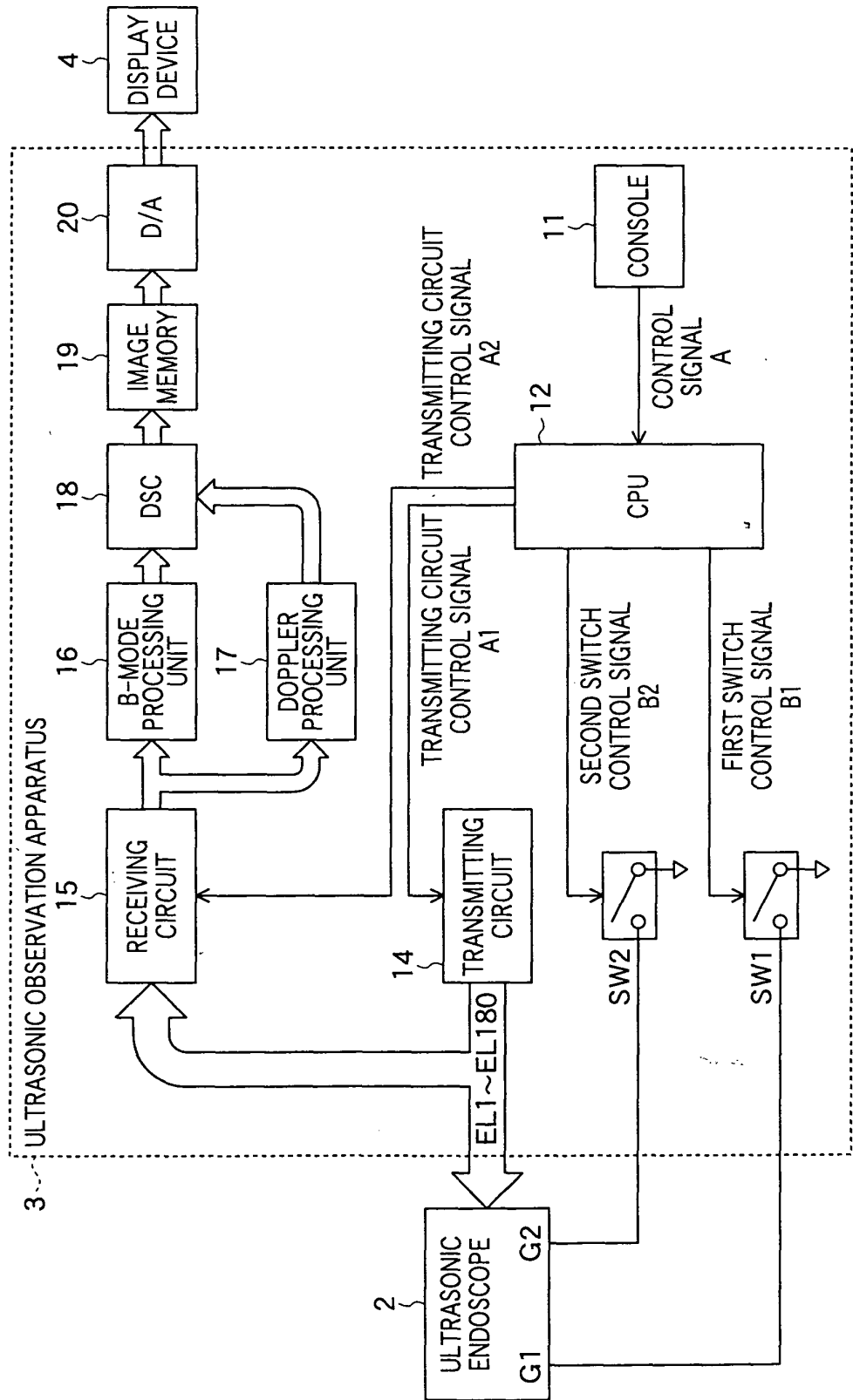
45

50

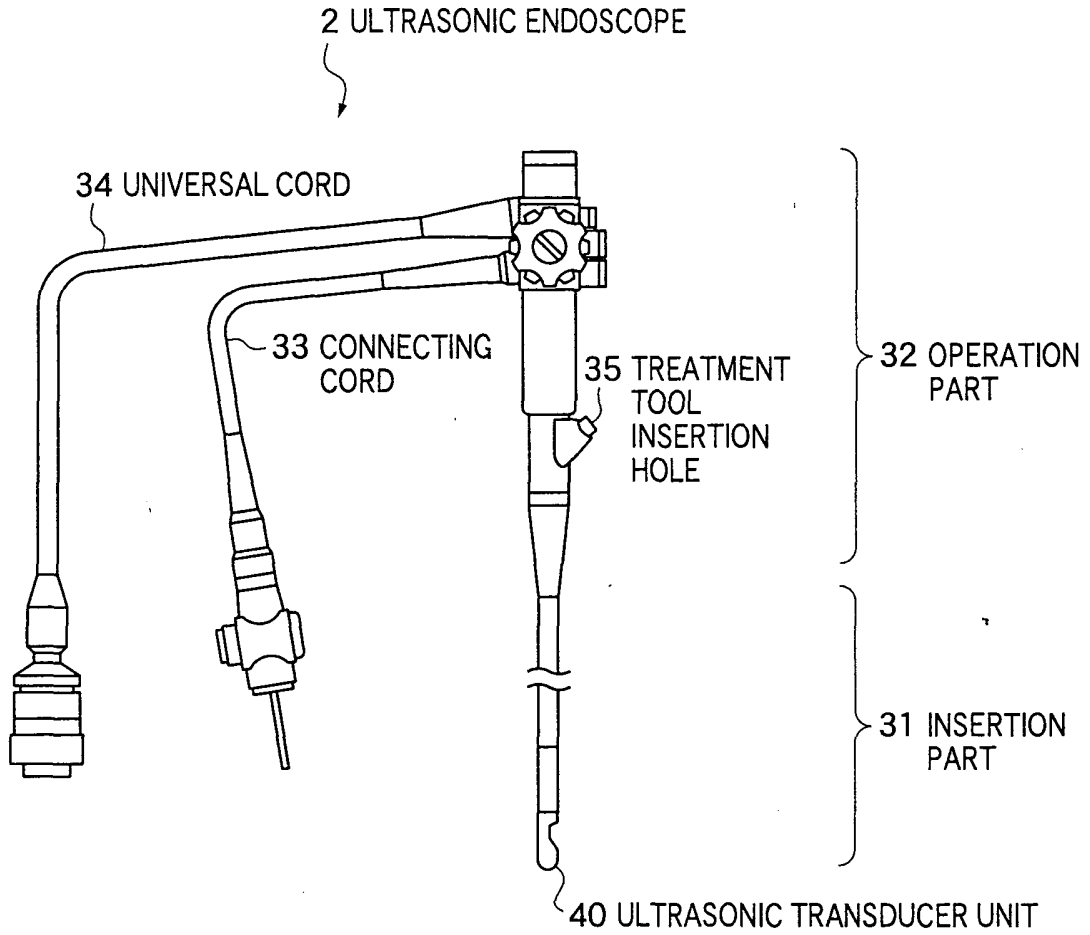
55

**FIG.1**

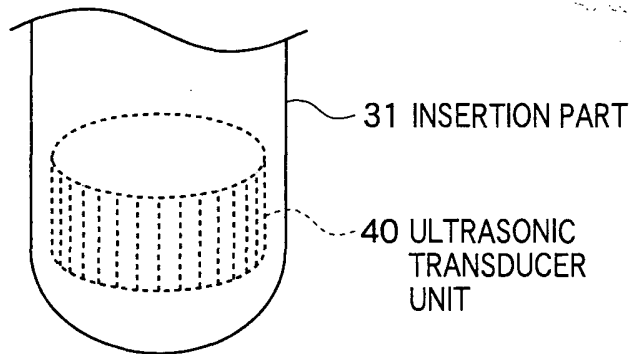
1 ULTRASONIC ENDOSCOPIC APPARATUS



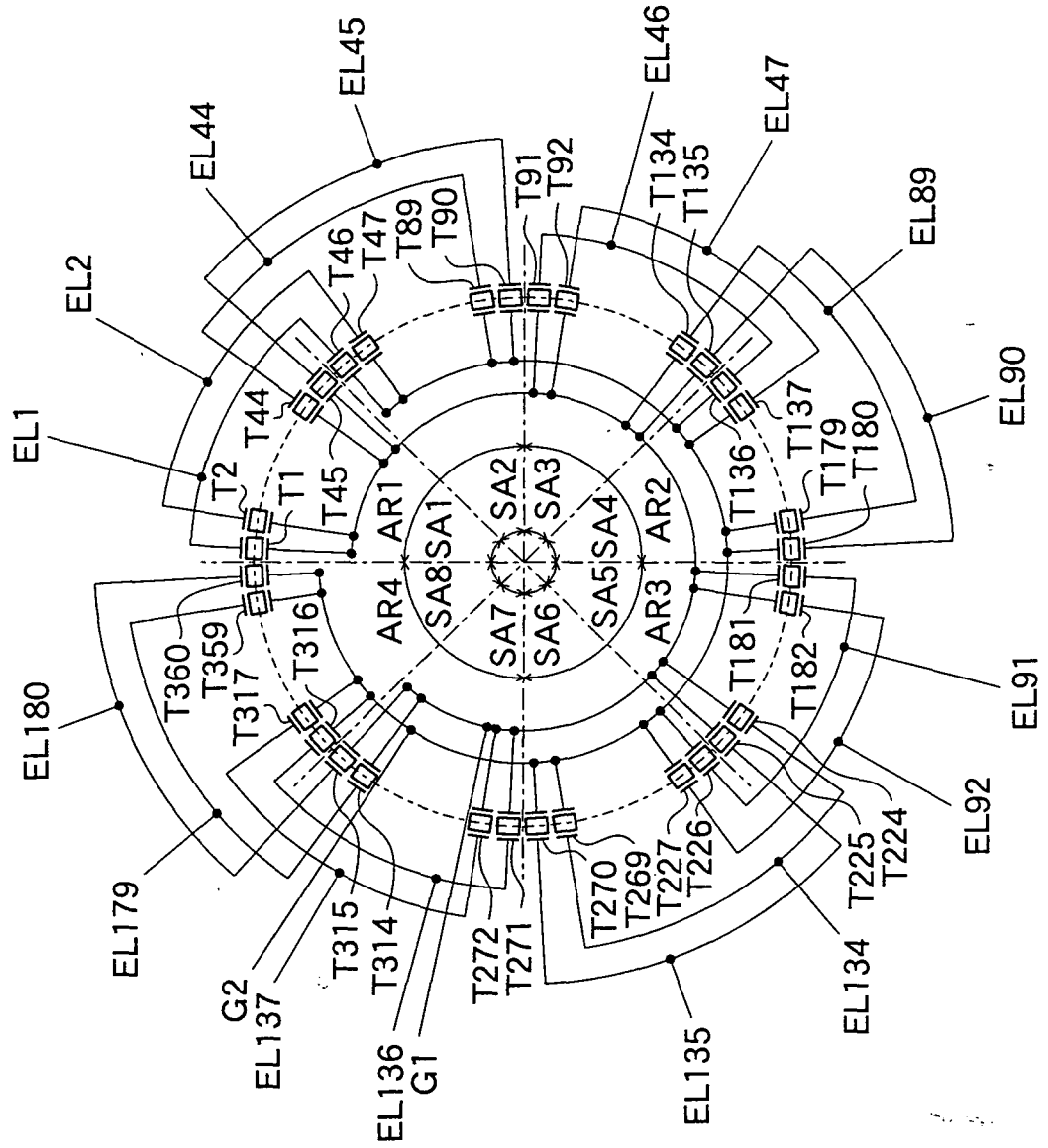
**FIG.2**

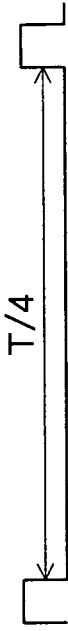


**FIG.3**



**FIG.4**





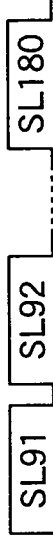
**FIG.5A**

FRAME TIMING



**FIG.5B**

TRANSMISSION  
TIMING  
(DIVISIONAL  
REGION AR1)



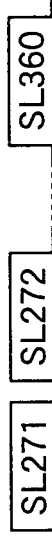
**FIG.5C**

TRANSMISSION  
TIMING  
(DIVISIONAL  
REGION AR2)



**FIG.5D**

TRANSMISSION  
TIMING  
(DIVISIONAL  
REGION AR3)

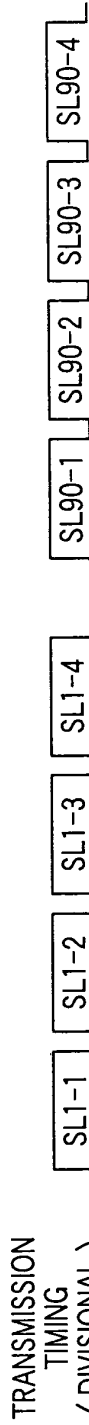


**FIG.5E**

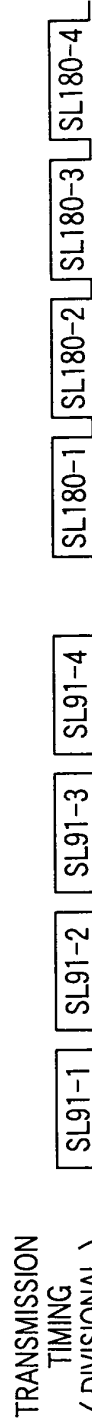
TRANSMISSION  
TIMING  
(DIVISIONAL  
REGION AR4)



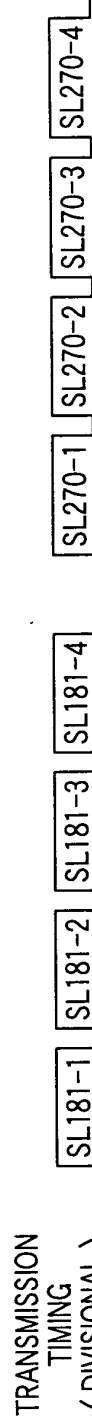
**FIG. 6A**



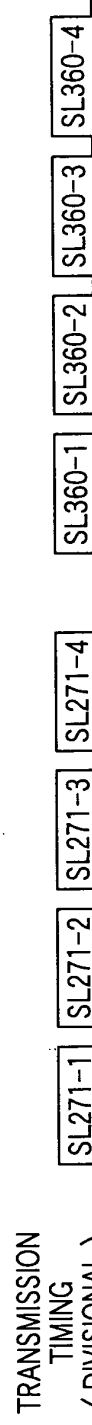
**FIG. 6B**



**FIG. 6C**



**FIG. 6D**

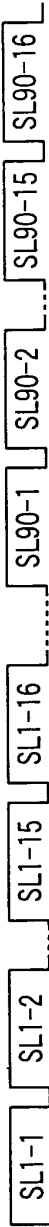


**FIG. 6E**



**FIG.7A**

TRANSMISSION  
TIMING  
(DIVISIONAL  
REGION AR1)



**FIG.7B**

TRANSMISSION  
TIMING  
(DIVISIONAL  
REGION AR2)



**FIG.7C**

TRANSMISSION  
TIMING  
(DIVISIONAL  
REGION AR3)



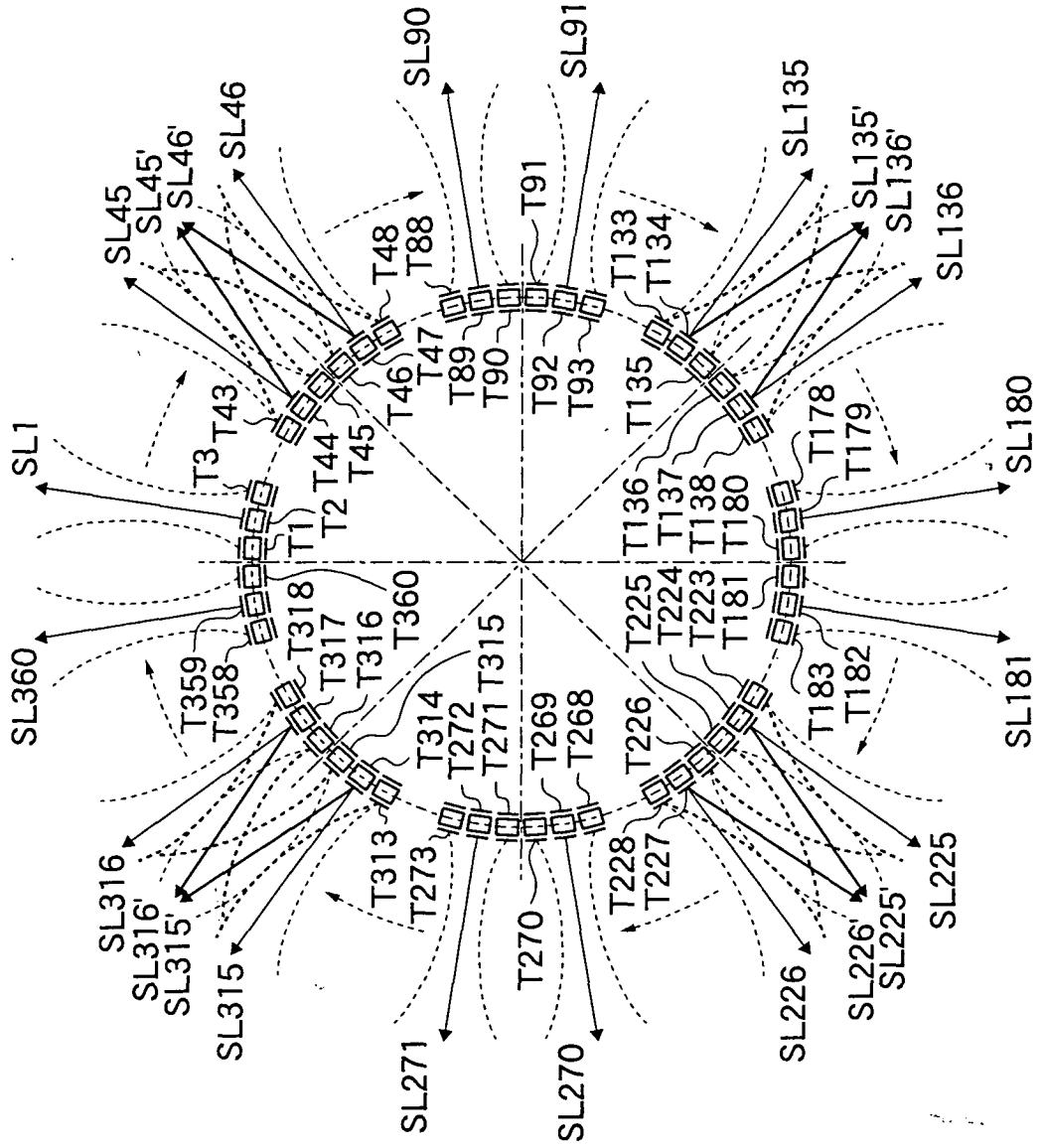
**FIG.7D**

TRANSMISSION  
TIMING  
(DIVISIONAL  
REGION AR4)



**FIG.7E**

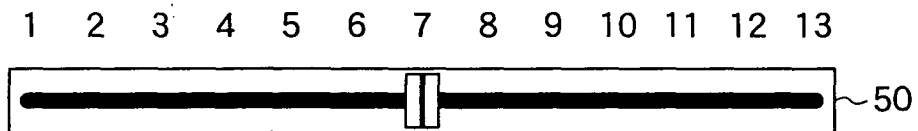
**FIG.8**



**FIG.9**

COMBINATION No.	1	2	3	4	5	6	
SENSITIVITY	s	5s/4	6s/4	7s/4	8s/4	9s/4	
FRAME RATE	f	4f/5	4f/6	4f/7	4f/8	4f/9	
COMBINATION No.	7	8	9	10	11	12	13
SENSITIVITY	10s/4	11s/4	12s/4	13s/4	14s/4	15s/4	16s/4
FRAME RATE	4f/10	4f/11	4f/12	4f/13	4f/14	4f/15	4f/16

**FIG.10**

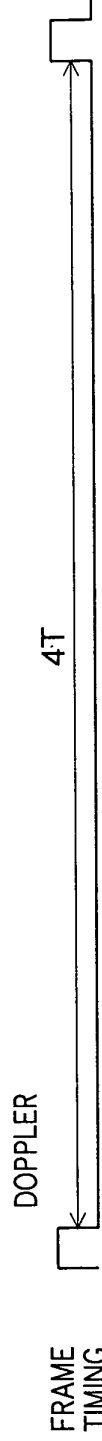




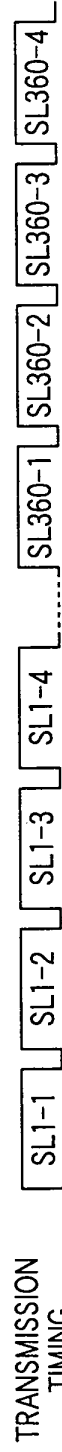
**FIG. 11A**  
PRIOR ART



**FIG. 11B**  
PRIOR ART



**FIG. 11C**  
PRIOR ART



**FIG. 11D**  
PRIOR ART



DOCUMENTS CONSIDERED TO BE RELEVANT			
Category	Citation of document with indication, where appropriate, of relevant passages	Relevant to claim	CLASSIFICATION OF THE APPLICATION (IPC)
X	US 5 081 993 A (KITNEY ET AL) 21 January 1992 (1992-01-21) * column 1, line 46 - column 2, line 44; figures 1-18 * * column 3, line 34 - column 4, line 13 * * column 5, line 29 - column 6, line 46 * * column 11, line 2 - line 44 * -----	1-13	A61B8/12 B06B1/06 G01S15/89
A	US 4 841 977 A (GRIFFITH ET AL) 27 June 1989 (1989-06-27) * column 4, line 34 - column 8, line 46; figures 1-31 * * column 13, line 4 - column 14, line 4 * * column 15, line 15 - column 18, line 40 * -----	1-13	
A	US 2003/213305 A1 (MAMAYEK DONALD S) 20 November 2003 (2003-11-20) * paragraph [0003] - paragraph [0013] * * paragraph [0022] - paragraph [0028]; figures 1-6 * -----	1-13	TECHNICAL FIELDS SEARCHED (IPC)
A	US 5 685 311 A (HARA ET AL) 11 November 1997 (1997-11-11) * column 1, line 1 - column 2, line 55; figures 1-14 * * column 5, line 20 - line 35 * * column 10, line 24 - line 67 * ----- -/--	1-13	A61B B06B G10K G01N G01S
The present search report has been drawn up for all claims			
Place of search The Hague		Date of completion of the search 27 October 2005	Examiner Neef, T
CATEGORY OF CITED DOCUMENTS X : particularly relevant if taken alone Y : particularly relevant if combined with another document of the same category A : technological background O : non-written disclosure P : intermediate document		T : theory or principle underlying the invention E : earlier patent document, but published on, or after the filing date D : document cited in the application L : document cited for other reasons ..... & : member of the same patent family, corresponding document	

2  
EPO FORM 1503 03.82 (P04C01)



DOCUMENTS CONSIDERED TO BE RELEVANT			
Category	Citation of document with indication, where appropriate, of relevant passages	Relevant to claim	CLASSIFICATION OF THE APPLICATION (IPC)
A	SCHWARZ H P ET AL INSTITUTE OF ELECTRICAL AND ELECTRONICS ENGINEERS: "A 100-ELEMENT ULTRASONIC CIRCULAR ARRAY FOR ENDOSCOPIC APPLICATION IN MEDICINE AND NDT" PROCEEDINGS OF THE ANNUAL CONFERENCE OF THE ENGINEERING IN MEDICINE AND BIOLOGY SOCIETY. PHILADELPHIA, NOV. 1 - 4, 1990, NEW YORK, IEEE, US, vol. VOL. 1 CONF. 12, 1 November 1990 (1990-11-01), pages 287-290, XP000239520 * the whole document *	1-13	TECHNICAL FIELDS SEARCHED (IPC)
A	US 4 448 075 A (TAKEMURA ET AL) 15 May 1984 (1984-05-15) * column 1, line 8 - column 3, line 52; figures 1-10 * * column 4, line 58 - column 6, line 64 *	1-13	
A	US 5 630 873 A (WEISER ET AL) 20 May 1997 (1997-05-20) * column 7, line 41 - line 61; figures 15,16 * * column 1, line 29 - column 2, line 56 *	1-13	
The present search report has been drawn up for all claims			
Place of search The Hague		Date of completion of the search 27 October 2005	Examiner Neef, T
<b>CATEGORY OF CITED DOCUMENTS</b> X : particularly relevant if taken alone Y : particularly relevant if combined with another document of the same category A : technological background O : non-written disclosure P : intermediate document		T : theory or principle underlying the invention E : earlier patent document, but published on, or after the filing date D : document cited in the application L : document cited for other reasons ..... & : member of the same patent family, corresponding document	

2  
EPO FORM 1503 03/82 (P04C01)

ANNEX TO THE EUROPEAN SEARCH REPORT  
ON EUROPEAN PATENT APPLICATION NO.

EP 05 01 7874

This annex lists the patent family members relating to the patent documents cited in the above-mentioned European search report.  
The members are as contained in the European Patent Office EDP file on  
The European Patent Office is in no way liable for these particulars which are merely given for the purpose of information.

27-10-2005

Patent document cited in search report	Publication date	Patent family member(s)	Publication date
US 5081993 A	21-01-1992	AT 201317 T	15-06-2001
		DE 3856471 D1	28-06-2001
		DE 3856471 T2	25-10-2001
		DK 117890 A	10-07-1990
		EP 0386058 A1	12-09-1990
		GB 2212267 A	19-07-1989
		WO 8904142 A1	18-05-1989
		GB 2246632 A	05-02-1992
		JP 11070112 A	16-03-1999
		JP 2905489 B2	14-06-1999
		JP 3500726 T	21-02-1991
US 4841977 A	27-06-1989	AU 599818 B2	26-07-1990
		AU 1941988 A	21-12-1988
		AU 5367090 A	23-08-1990
		AU 5367190 A	16-08-1990
		CA 1321829 C	31-08-1993
		DK 23689 A	19-01-1989
		EP 0328564 A1	23-08-1989
		JP 3326396 B2	24-09-2002
		JP 11243596 A	07-09-1999
		JP 2500398 T	08-02-1990
		WO 8809150 A1	01-12-1988
US 2003213305 A1	20-11-2003	US 6499348 B1	31-12-2002
US 5685311 A	11-11-1997	DE 19539163 A1	02-05-1996
		JP 3487981 B2	19-01-2004
		JP 8172695 A	02-07-1996
US 4448075 A	15-05-1984	GB 2075797 A	18-11-1981
		JP 1498048 C	29-05-1989
		JP 56158648 A	07-12-1981
		JP 63046693 B	16-09-1988
		KR 8500056 B1	15-02-1985
US 5630873 A	20-05-1997	NONE	

专利名称(译)	超声波内窥镜和超声波内窥镜装置		
公开(公告)号	<a href="#">EP1627603A1</a>	公开(公告)日	2006-02-22
申请号	EP2005017874	申请日	2005-08-17
[标]申请(专利权)人(译)	富士摄影胶片公司		
申请(专利权)人(译)	富士胶片有限公司.		
当前申请(专利权)人(译)	富士胶片株式会社		
[标]发明人	SATOH YOSHIAKI TSUJITA KAZUHIRO		
发明人	SATOH, YOSHIAKI TSUJITA, KAZUHIRO		
IPC分类号	A61B8/12 B06B1/06 G01S15/89 A61B8/14		
CPC分类号	A61B8/12 A61B8/145 A61B8/4461 A61B8/4483 A61B8/4488 G01S15/8922 G01S15/8979		
优先权	2004240787 2004-08-20 JP		
其他公开文献	EP1627603B1		
外部链接	<a href="#">Espacenet</a>		

摘要(译)

在能够插入患者体内并对超声波断层图像成像的超声波内窥镜中，电子径向扫描操作中的帧速率得到改善。超声波内窥镜包括：超声波换能器单元（40），包括多个超声波换能器（T1至T360），每个超声波换能器具有第一电极和第二电极，用于发送和接收超声波；多个第一互连（EL1至EL180），每个第一互连连接到预定超声换能器的第一电极；多个第二互连（G1和G2），每个第二互连连接到超声换能器的第二电极，所述超声换能器的第一电极彼此不连接；其中，当通过多个第一互连和多个第二互连选择性地提供驱动信号时，超声波换能器单元（40）通过在多个角度区域的每一个中同时传输相同数量的超声波束来执行扫描操作。

