



- (51) **International Patent Classification:**
A61B 8/08 (2006.01) *A61B 8/00* (2006.01)
- (21) **International Application Number:**
PCT/EP2018/071721
- (22) **International Filing Date:**
10 August 2018 (10.08.2018)
- (25) **Filing Language:** English
- (26) **Publication Language:** English
- (30) **Priority Data:**
62/546590 17 August 2017 (17.08.2017) US
- (71) **Applicant: KONINKLIJKE PHILIPS N.V.** [NL/NL];
High Tech Campus 5, 5656 AE Eindhoven (NL).
- (72) **Inventor: ROUNDHILL, David Nigel;** High Tech Cam-
pus 5, 5656 AE Eindhoven (NL).
- (74) **Agent: STEFFEN, Thomas et al.;** Philips International
B.V. – Intellectual Property & Standards High Tech Cam-
pus 5, 5656 AE Eindhoven (NL).
- (81) **Designated States** (*unless otherwise indicated, for every
kind of national protection available*): AE, AG, AL, AM,
AO, AT, AU, AZ, BA, BB, BG, BH, BN, BR, BW, BY, BZ,
CA, CH, CL, CN, CO, CR, CU, CZ, DE, DJ, DK, DM, DO,
DZ, EC, EE, EG, ES, FI, GB, GD, GE, GH, GM, GT, HN,
HR, HU, ID, IL, IN, IR, IS, JO, JP, KE, KG, KH, KN, KP,

KR, KW, KZ, LA, LC, LK, LR, LS, LU, LY, MA, MD, ME,
MG, MK, MN, MW, MX, MY, MZ, NA, NG, NI, NO, NZ,
OM, PA, PE, PG, PH, PL, PT, QA, RO, RS, RU, RW, SA,
SC, SD, SE, SG, SK, SL, SM, ST, SV, SY, TH, TJ, TM, TN,
TR, TT, TZ, UA, UG, US, UZ, VC, VN, ZA, ZM, ZW.

- (84) **Designated States** (*unless otherwise indicated, for every
kind of regional protection available*): ARIPO (BW, GH,
GM, KE, LR, LS, MW, MZ, NA, RW, SD, SL, ST, SZ, TZ,
UG, ZM, ZW), Eurasian (AM, AZ, BY, KG, KZ, RU, TJ,
TM), European (AL, AT, BE, BG, CH, CY, CZ, DE, DK,
EE, ES, FI, FR, GB, GR, HR, HU, IE, IS, IT, LT, LU, LV,
MC, MK, MT, NL, NO, PL, PT, RO, RS, SE, SI, SK, SM,
TR), OAPI (BF, BJ, CF, CG, CI, CM, GA, GN, GQ, GW,
KM, ML, MR, NE, SN, TD, TG).

Declarations under Rule 4.17:

- *as to applicant's entitlement to apply for and be granted a
patent (Rule 4.17(ii))*

Published:

- *with international search report (Art. 21(3))*

- (54) **Title:** ULTRASOUND SYSTEM WITH EXTRACTION OF IMAGE PLANES FROM VOLUME DATA USING TOUCH IN-
TERACTION WITH AN IMAGE

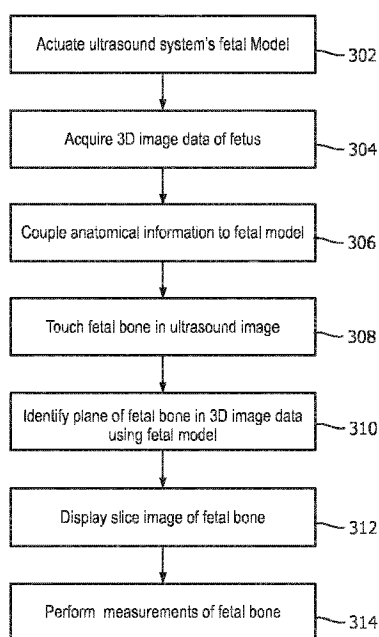

FIG. 6

- (57) **Abstract:** An ultrasound system includes an image extraction processor which is responsive to the touching of at least a portion of desired anatomy in an ultrasound image on a touchscreen display to extract an image of the desired anatomy from a 3D volumetric data set which includes the desired anatomy. The system and method can also be used to extract standard view images from volumetric image data of anatomy.

ULTRASOUND SYSTEM WITH EXTRACTION OF IMAGE PLANES
FROM VOLUME DATA USING TOUCH INTERACTION WITH AN IMAGE

5 This invention relates to medical diagnostic
ultrasound systems and, in particular, to ultrasound
systems which enable the extraction of image planes
of selected anatomy by touch interaction with an
image.

10 Obstetrical fetal imaging is one of the most
important branches of ultrasonic imaging. Ultrasound
is a non-ionizing imaging modality and hence safe for
developing fetuses. Ultrasound imaging is used to
monitor fetal development and also to predict
15 expected delivery dates from estimations of fetal
age. Fetal age estimation is done by measuring the
dimensions of various bones of a developing fetus,
such as the skull and limbs. Clinically validated
algorithms use these measurements in combination to
estimate fetal age. A typical ultrasound system
20 configured for obstetrical imaging is equipped with
protocols to guide a sonographer in acquiring the
necessary images for the measurements and also will
have the age estimation algorithms onboard the
system.

25 Acquiring the necessary images for accurate
measurements of the fetal bone structure is not
always easy, however. The most accurate measurements
are made when the longitudinal dimension of a limb
bone is fully captured in a two-dimensional (2D)
30 image plane, but manipulating the image plane with a
standard 2D imaging probe is often problematic. The
fetus can move frequently and can assume various
positions in the womb, putting the limbs into
orientations which are not always accessible to the
35 2D plane extending from the probe. A solution for
this situation is provided by 3D volumetric imaging.

The 3D volumetric region extending from the aperture of a 3D imaging probe can be positioned to capture the volume in which the fetus is located, regardless of the current position of the fetus. A volume image
5 can be captured quickly and then analyzed and diagnosed at leisure by viewing different slice planes of the volume using multiplanar reformatting to extract desired planes containing the necessary bones for measurement. But a problem often
10 encountered in such extraction is that the desired anatomy may not always be clearly visible, as it can be obstructed by surrounding tissue, the umbilical cord, or the wall of the uterus. Thus it sometimes becomes necessary to "trim" away obscuring tissue in
15 a volume image and search carefully to find the images of the tiny structures required for measurements. It is desirable to expedite this process so that the desired anatomy can be viewed quickly and completely for accurate measurement.

20 In accordance with the principles of the present invention, an ultrasound system enables extraction of image planes of desired anatomy from a 3D volume image dataset using image processing which has been programmed to identify the desired anatomy in 3D
25 volume images. A 3D volume image dataset is acquired and an ultrasound image displayed on a touchscreen display. When a user sees a section of desired anatomy in an ultrasound image, the user touches the anatomy on the touchscreen. This sends a cue to an
30 image extraction processor, which then examines image planes around the identified anatomical location and locates an image plane containing the desired anatomy. An image of the identified anatomy is displayed to a user, and the display may also
35 automatically include a measurement of the desired

anatomy useful for a particular exam such as a fetal exam.

In the drawings:

FIGURE 1 illustrates a tablet ultrasound system
5 with a touchscreen display and an ultrasound probe
for use with the system.

FIGURE 2 illustrates a 3D volume image
containing a fetal femur and a cut plane intersecting
the femur.

10 FIGURE 3 is a picture of a femur indicating the
location on the bone where it is intersected by the
cut plane when imaged with a volume image as shown in
FIGURE 2.

FIGURE 4 is an ultrasound image display showing
15 an image of the cut plane of FIGURE 2.

FIGURE 5 is a block diagram of an ultrasound
system constructed in accordance with a first
implementation of the present invention which uses a
fetal model to identify the image planes of fetal
20 bones in volume image data.

FIGURE 6 is a flowchart illustrating the
operation of the ultrasound system of FIGURE 5.

FIGURE 7 is an ultrasound display of a fetal
bone in a longitudinal view suitable for measurement
25 which has been identified and extracted in accordance
with the principles of the present invention.

FIGURE 8 is a block diagram of an ultrasound
system constructed in accordance with a second
implementation of the present invention which uses a
neural network model to identify the image planes of
30 fetal bones in volume image data.

FIGURE 9 is a flowchart illustrating the
operation of the ultrasound system of FIGURE 8.

Referring to FIGURE 1, an ultrasound system of
35 the present invention is shown. The system comprises

a tablet ultrasound system with a touchscreen 120. A suitable commercial system with these characteristics is the Lumify™ ultrasound system, available from Philips Healthcare of Andover, MA. The touchscreen display will display an ultrasound image 12 as well as patient and system information 22 and touchscreen controls 24 by which a user controls the operation of the ultrasound system. To the right of the tablet system is an ultrasound probe 10 which transmits and receives ultrasonic energy with a two-dimensional transducer array located at its distal end 14. The two-dimensional array is capable of electronically scanning and acquiring echo signals for imaging over a volumetric region of a subject. Three-dimensional imaging may also be performed with a transducer having an oscillating one-dimensional array transducer. The ultrasound probe 10 is coupled either by a cable or wirelessly to the tablet ultrasound system, which is capable of Bluetooth and Wifi communication as indicated by waves 126. The probe 10 is shown with a stub antenna 16 at its proximal end for communication with the tablet ultrasound system.

FIGURE 2 depicts a volume 72 of spatially arranged image voxels produced from echoes acquired by the ultrasound probe 10 for 3D imaging. In this example the volume of image data contains image data of a fetal femur 92 which was in the scanning region of the probe. The femur is shown in dotted phantom, depicting that the bone is obscured inside the volume by surrounding voxels of tissue. The longitudinal dimension of the femur extends from the front to the back of the volume 72. A cut plane 70 through the volume of image data is also illustrated. In this example the plane 70 of pixels of image data

intersects the femur 90. Thus, the image produced from the pixels in image plane 70 will include a cross-sectional area 90 of the femur bone 92. FIGURE 3 is a picture of a femur bone 92 in perspective
5 which indicates the location 90 of the slice through the bone which is in image plane 70 in FIGURE 2.

With this as background, FIGURE 4 shows an ultrasound system display 100 displaying a planar ultrasound image 12. This image typifies how an
10 image of slice plane 70 will appear, including the cross-sectional view 90 of the femur 92 surrounded by pixels of the tissue located around the bone. In an implementation of the present invention, a user touches the section 90 of the femur on the display
15 which is visible in the image. Touching the touchscreen sends a signal to the ultrasound system, indicating to the system a location in the image data around which the system is to analyze the volumetric image data to find an image plane containing a
20 longitudinal view of the femur. The system already knows that the user is conducting an obstetrical exam, which was made known to the system when the user selected an obstetrical probe 10. Optionally, the user may also indicate to the system that it is a
25 fetal femur bone which is to be located. An onboard image extraction processor now explores the volumetric image data in differently oriented planes which intersect the location in the image data marked by the touch of the user on bone section 90 on the
30 touchscreen display until a plane containing a longitudinal image of the femur bone is found.

One implementation of an ultrasound system configured to perform this analysis and produce the desired image is shown in block diagram form in
35 FIGURE 5. A transducer array 112 is provided in an

ultrasound probe 10 for transmitting ultrasonic waves and receiving echo information over a volumetric region of the body. The transducer array 112 may be a two-dimensional array of transducer elements
5 capable of electronically scanning in two or three dimensions, in both elevation (in 3D) and azimuth, as shown in the drawing. Alternatively, the transducer may be a one-dimensional array capable of scanning image planes which is oscillated back and forth to
10 sweep the image plane through a volumetric region and thereby scan the region for three-dimensional imaging, such as that described in US Pat. 7,497,830 (Li et al.) A two-dimensional transducer array 112 is coupled to a microbeamformer 114 in the probe
15 which controls transmission and reception of signals by the array elements. Microbeamformers are capable of at least partial beamforming of the signals received by groups or "patches" of transducer elements as described in US Pats. 5,997,479 (Savord
20 et al.), 6,013,032 (Savord), and 6,623,432 (Powers et al.) The microbeamformer is coupled by the probe cable to a transmit/receive (T/R) switch 16 which switches between transmission and reception and protects the main system beamformer 20 from high
25 energy transmit signals. The transmission of ultrasonic beams from the transducer array 112 under control of the microbeamformer 114 is directed by a transmit controller 18 coupled to the T/R switch and the beamformer 20, which receives input from the
30 user's operation of the user interface or controls 24 on the touchscreen display. Among the transmit characteristics controlled by the transmit controller are the spacing, amplitude, phase, and polarity of transmit waveforms. Beams formed in the direction of
35 pulse transmission may be steered straight ahead from

the transducer array, or at different angles for a wider sector field of view, the latter being typical of most obstetrical imaging probes.

5 The echoes received by a contiguous group of transducer elements are beamformed by appropriately delaying them and then combining them. The partially beamformed signals produced by the microbeamformer 114 from each patch are coupled to a main beamformer 20 where partially beamformed signals from individual patches of transducer elements are delayed and
10 combined into a fully beamformed coherent echo signal. For example, the main beamformer 20 may have 128 channels, each of which receives a partially beamformed signal from a patch of 12 transducer
15 elements. In this way the signals received by over 1500 transducer elements of a two-dimensional array transducer can contribute efficiently to a single beamformed signal.

The coherent echo signals undergo signal
20 processing by a signal processor 26, which includes filtering by a digital filter and noise reduction as by spatial or frequency compounding. The digital filter of the signal processor 26 can be a filter of the type disclosed in U.S. Patent No. 5,833,613
25 (Averkiou et al.), for example. The processed echo signals are demodulated into quadrature (I and Q) components by a quadrature demodulator 28, which provides signal phase information and can also shift the signal information to a baseband range of
30 frequencies.

The beamformed and processed coherent echo signals are coupled to a B mode processor 52 which produces a B mode image of structure in the body such as tissue. The B mode processor performs amplitude
35 (envelope) detection of quadrature demodulated I and

Q signal components by calculating the echo signal
amplitude in the form of $(I^2+Q^2)^{1/2}$. The quadrature
echo signal components are also coupled to a Doppler
processor 46, which stores ensembles of echo signals
5 from discrete points in an image field which are then
used to estimate the Doppler shift at points in the
image with a fast Fourier transform (FFT) processor.
The Doppler shift is proportional to motion at points
in the image field, e.g., blood flow and tissue
10 motion. For a color Doppler image, which may be
formed for analysis of fetal blood flow, the
estimated Doppler flow values at each point in a
blood vessel are wall filtered and converted to color
values using a look-up table. Either the B mode
15 image or the Doppler image may be displayed alone, or
the two shown together in anatomical registration in
which the color Doppler overlay shows the blood flow
in tissue and vessels in the imaged region.

The B mode image signals and the Doppler flow
20 values when used are coupled to a 3D image data
memory, which stores the image data in x, y, and z
addressable memory locations corresponding to spatial
locations in a scanned volumetric region of a
subject. This volumetric image data is coupled to a
25 volume renderer 34 which converts the echo signals of
a 3D data set into a projected 3D image as viewed
from a given reference point as described in US Pat.
6,530,885 (Entrekin et al.) The reference point, the
perspective from which the imaged volume is viewed,
30 may be changed by a control on the touchscreen
display, which enables the volume to be tilted or
rotated to diagnose the region from different
viewpoints.

In accordance with the principles of the present
35 invention the volumetric image data used to produce

the volume rendering is coupled to an image extraction processor which in this implementation is a fetal model 86. The fetal model is a processor and memory which stores a library of differently sized and/or shaped models in data form of typical structures of interest in a fetal exam. The library may contain different sets of models, each representing typical fetal structure at a particular age of fetal development, such as the first and second trimesters of development, for instance. The models are data representing meshes of bones of the fetal skeleton and skin (surface) of a developing fetus. The meshes of the bones are interconnected as are the actual bones of a skeleton so that their relative movements and ranges of articulation are constrained in the same manner as are those of an actual skeletal structure. Similarly the surface mesh is constrained to be within a certain range of distance of the bones it surrounds. When the user has informed the system of known anatomical information, such as the bone to be identified is believed to be a femur of a fetus in the second trimester, this information is coupled to the fetal model and used to select a particular model from the library as the starting point for analysis. The models are deformable within constraint limits, e.g., fetal age, by altering parameters of a model to warp the model, such as an adaptive mesh representing an approximate surface of a typical femur, and thereby fit the model by deformation to structural landmarks in the volumetric image data set. An adaptive mesh model is desirable because it can be warped within the limits of its mesh continuity and other constraints in an effort to fit the deformed model to structure in different image planes intersecting the

identified bone location 90. This process is continued by an automated shape processor until data is found in a plane which can be fitted by the model and thus identified as the desired anatomy. The
5 planes in the volumetric image data which are examined may be selected by the fetal model operating on the volumetric image data provided by the volume renderer 34, when the bone model is configured to do this. Alternatively, a series of differently
10 oriented image planes intersecting the specified location 90 can be extracted from the volume data by a multiplanar reformatter 42 and provided to the fetal model 86 for analysis and fitting. The multiplanar reformatter selects echo data which are
15 received from points in a common plane in a volumetric region of the body which can be displayed as an ultrasonic image of that plane, as described in US Pat. 6,443,896 (Detmer). In the instant system the multiplanar reformatter is programmed to couple
20 to the fetal model a sequence of differently oriented planes of image data which intersect the location marked by the user's touch until a plane is found with image data fitted by the model. In either case, the identification of the plane of an image with the
25 desired anatomy is coupled back to the multiplanar reformatter for display of the desired image plane. The image extraction processor may also provide and/or seek verification of the anatomy being identified, as by displaying a message "Femur?" to
30 the user when it appears that the user is seeking to display the femur and verification of this is desired either by the processor or as reassurance to the user. The foregoing model deformation and fitting is explained in further detail in international patent
35 application number WO 2015/019299 (Mollus et al.)

entitled "MODEL-BASED SEGMENTATION OF AN ANATOMICAL
STRUCTURE." See also international patent
application number WO 2010/150156 (Peters et al.)
entitled "ESTABLISHING A CONTOUR OF A STRUCTURE BASED
5 ON IMAGE INFORMATION" and US pat. appl. pub. no.
2017/0128045 (Roundhill et al.) entitled "TRANSLATION
OF ULTRASOUND ARRAY RESPONSIVE TO ANATOMICAL
ORIENTATION."

Once the orientation coordinates of an image
10 plane containing the desired anatomy has been found,
in this example a longitudinal view of a femur bone,
this information is coupled to the multiplanar
reformatter by the fetal bone model which selects
that plane of data from the volumetric image data for
15 display. The planar image data is coupled to an
image processor 30 for scan conversion if necessary
and further enhancement, buffering and temporary
storage for display on an image display 40. In a
preferred implementation the image processor also
20 adds the desired measurement to the image, which is
readily done as ultrasonic image data is spatially
accurate. A graphics processor 36 produces a display
overlay containing measurement graphics and the
measurement together with the image of the desired
25 fetal bone 92 as shown on image display 100 in FIGURE
7. If desired, the ultrasound system can
automatically label the identified structure as a
femur, and can also be configured to automatically
call up the fetal age estimation program and enter
30 the bone measurement into the program for expedited
fetal age estimation.

A method for operating the ultrasound system of
FIGURE 5 to extract an image of desired fetal anatomy
from volumetric image data is illustrated in FIGURE
35 6. In step 302 the fetal model of the ultrasound

system is actuated. In step 304 3D (volumetric) image data of a fetus is acquired. In step 306 known anatomical information is optionally coupled to the fetal model, such as the particular bone to be
5 identified and the age (trimester) of the fetus. In step 308 a user touches the desired fetal bone on a touchscreen display of an ultrasound image in which at least a portion of the bone is visible. This touch identification is used by a fetal model in step
10 310 to identify an image plane containing the desired bone in the 3D image data. In step 312 a slice image of an identified image plane of the desired fetal bone in longitudinal view is displayed. In step 314 measurements of the fetal bone are performed which,
15 optionally, may be done automatically as described above.

FIGURE 8 illustrates in block diagram form an ultrasound system comprising a second implementation of the present invention. In the system of FIGURE 8,
20 system elements which were shown and described in FIGURE 5 are used for like functions and operations and will not be described again. In the system of FIGURE 8 the image extraction processor comprises a neural net model 80. A neural net model makes use of
25 a development in artificial intelligence known as "deep learning." Deep learning is a rapidly developing branch of machine learning algorithms that mimic the functioning of the human brain in analyzing problems. The human brain recalls what was learned
30 from solving a similar problem in the past, and applied that knowledge to solve a new problem. Exploration is underway to ascertain possible uses of this technology in a number of areas such as pattern recognition, natural language processing and computer
35 vision. Deep learning algorithms have a distinct

5 advantage over traditional forms of computer programming algorithms in that they can be generalized and trained to recognize image features by analyzing image samples rather than writing custom computer code. The anatomy visualized in an ultrasound system would not seem to readily lend itself to automated image recognition, however. Every person is different, and anatomical shapes, sizes, positions and functionality vary from person to person. Furthermore, the quality and clarity of ultrasound images will vary even when using the same ultrasound system. That is because body habitus will affect the ultrasound signals returned from the interior of the body which are used to form the images. Scanning a fetus through the abdomen of an expectant mother will often result in greatly attenuated ultrasound signals and poorly defined anatomy in the fetal images. Nevertheless, the system described in this application has demonstrated the ability to use deep learning technology to recognize anatomy in fetal ultrasound images through processing by a neural network model. The neural network model is first trained by presenting to it a plurality of images of known anatomy, such as fetal images with known fetal structure which is identified to the model. Once trained, live images acquired by a user during a fetal exam are analyzed by the neural net model in real time, which identifies the anatomy in the images.

30 Deep learning neural net models comprise software which may be written by a software designer, and are also publicly available from a number of sources. In the ultrasound system of FIGURE 8, the neural net model software is stored in a digital memory. An application which can be used to build a

neural net model called "NVidia Digits" is available at <https://developer.nvidia.com/digits>. NVidia Digits is a high-level user interface around a deep learning framework called "Caffe" which has been

5 developed by the Berkley Vision and Learning Center, <http://caffe.berkeleyvision.org/>. A list of common deep learning frameworks suitable for use in an implementation of the present invention is found at <https://developer.nvidia.com/deep-learning->

10 frameworks. Coupled to the neural net model 80 is a training image memory 82, in which ultrasound images of known fetal anatomy including fetal bones are stored and used to train the neural net model to identify that anatomy in 3D (volumetric) ultrasound

15 image data sets. Once the neural net model is trained by a large number of known fetal images, the neural net model receives a volume image data set of a fetus from the volume renderer 34. The neural net model may receive other cues in the form of

20 anatomical information such as the fact that an obstetrical exam is being performed and the trimester of the fetus, as described above. The neural net model also receives the locational signal generated by a user touching a portion of the desired anatomy

25 on a touchscreen display, a femur bone in this example. The neural net model then analyzes regions including the identified location until a femur bone is identified in the volume image data. The coordinates of a plane containing longitudinal image

30 data of the femur are coupled to the multiplanar reformatter 42, which extracts the desired femur image from the volumetric image data set and forwards it to the image processor for display as shown in FIGURE 7. As before, the ultrasound system may be

35 conditioned to automatically label and/or measure the

bone, display the measurement, and couple the measurement information to another program such as a gestational age estimation program.

5 A method for operating the ultrasound system of FIGURE 8 to extract an image of desired fetal anatomy from volumetric image data is illustrated in FIGURE 9. In step 202 a neural network model is trained to identify fetal bones in 3D fetal image data. In step 204 3D (volumetric) image data of a fetus is
10 acquired. In step 206 known anatomical information is optionally coupled to the fetal bone model, such as the particular bone to be identified and the age (trimester) of the fetus. In step 208 a user touches the desired fetal bone on a touchscreen display of an
15 ultrasound image in which at least a portion of the bone is visible. This touch identification of location in an image is used by a neural network model in step 210 to identify an image plane containing the desired bone in the 3D image data. In
20 step 212 a slice image of an identified image plane of the desired fetal bone is displayed. In step 214 measurements of the fetal bone are performed which, optionally, may be done automatically as described above.

25 Variations of the systems and methods described above will readily occur to those skilled in the art. A number of system components shown in FIGURES 5 and 8 can be located in the probe case. Some Lumify probes, for example, contain components from the
30 transducer through the B mode processor, outputting to the tablet display detected image signals over a USB cable. This methodology can be extended to include even additional components in the probe, if desired, such as the 3D image data memory and volume
35 rendering software. Thus, a number of components

which are described above as "system" components may alternatively be located in the ultrasound probe.

The techniques of the present invention can be used in other diagnostic areas besides obstetrics.

5 For instance, numerous ultrasound exams require standard views of anatomy for diagnosis. In
10 diagnoses of the kidney, a standard view is a coronal image plane of the kidney. In cardiology, two-chamber, three-chamber, and four-chamber views of the heart are standard views. A neural network model can be trained to recognize such views in 3D image data sets of the heart and then be used to select image planes of desired views from volumetric data and display them to a clinician. Other applications will
15 readily occur to those skilled in the art.

It should be noted that an ultrasound system suitable for use in an implementation of the present invention, and in particular the component structure of the ultrasound systems of FIGURES 5 and 8, may be
20 implemented in hardware, software or a combination thereof. The various embodiments and/or components of an ultrasound system, for example, the fetal bone model and deep learning software modules, or components, processors, and controllers therein, also
25 may be implemented as part of one or more computers or microprocessors. The computer or processor may include a computing device, an input device, a display unit and an interface, for example, for accessing the Internet. The computer or processor
30 may include a microprocessor. The microprocessor may be connected to a communication bus, for example, to access a PACS system or the data network for importing training images. The computer or processor may also include a memory. The memory devices such
35 as the 3D image data memory 32, the training image

memory, and the memory storing fetal bone model
libraries may include Random Access Memory (RAM) and
Read Only Memory (ROM). The computer or processor
further may include a storage device, which may be a
5 hard disk drive or a removable storage drive such as
a floppy disk drive, optical disk drive, solid-state
thumb drive, and the like. The storage device may
also be other similar means for loading computer
programs or other instructions into the computer or
10 processor.

As used herein, the term "computer" or "module"
or "processor" or "workstation" may include any
processor-based or microprocessor-based system
including systems using microcontrollers, reduced
15 instruction set computers (RISC), ASICs, logic
circuits, and any other circuit or processor capable
of executing the functions described herein. The
above examples are exemplary only, and are thus not
intended to limit in any way the definition and/or
20 meaning of these terms.

The computer or processor executes a set of
instructions that are stored in one or more storage
elements, in order to process input data. The
storage elements may also store data or other
25 information as desired or needed. The storage
element may be in the form of an information source
or a physical memory element within a processing
machine.

The set of instructions of an ultrasound system
30 including those controlling the acquisition,
processing, and transmission of ultrasound images as
described above may include various commands that
instruct a computer or processor as a processing
machine to perform specific operations such as the
35 methods and processes of the various embodiments of

the invention. The set of instructions may be in the form of a software program. The software may be in various forms such as system software or application software and which may be embodied as a tangible and non-transitory computer readable medium. Further, the software may be in the form of a collection of separate programs or modules such as a neural network model module, a program module within a larger program or a portion of a program module. The software also may include modular programming in the form of object-oriented programming. The processing of input data by the processing machine may be in response to operator commands, or in response to results of previous processing, or in response to a request made by another processing machine.

Furthermore, the limitations of the following claims are not written in means-plus-function format and are not intended to be interpreted based on 35 U.S.C. 112, sixth paragraph, unless and until such claim limitations expressly use the phrase "means for" followed by a statement of function devoid of further structure.

25

WHAT IS CLAIMED IS:

1. An ultrasonic diagnostic imaging system for
extracting a desired view of anatomy from volume
5 image data which includes the anatomy comprising:

an ultrasound probe adapted to acquire volume
image data which includes image data of a desired
anatomy;

10 a display adapted to display an ultrasound image
from the acquired image data showing at least a
portion of the desired anatomy on a touchscreen
display;

15 an image extraction processor, responsive to the
volume image data and a touch of the desired anatomy
on the touchscreen display, and adapted to extract an
image of the desired anatomy from the volume image
data;

20 wherein the display is further adapted to
display the extracted image of the desired anatomy.

2. The ultrasonic diagnostic imaging system of
Claim 1, further comprising a B mode processor,
wherein the image extraction processor further
comprises a fetal model.

25 3. The ultrasonic diagnostic imaging system of
Claim 1, further comprising a B mode processor,
wherein the image extraction processor further
comprises a neural network model.

30 4. The ultrasonic diagnostic imaging system of
Claim 3, wherein the neural network model is adapted
to be trained with known images of the desired
anatomy.

35

5. The ultrasonic diagnostic imaging system of Claim 4, wherein the neural network model is further adapted to recognize the desired anatomy in B mode image data of the volume image data.

5

6. The ultrasonic diagnostic imaging system of Claim 5, wherein the neural network model is further adapted to recognize a plane of image data containing the desired anatomy in B mode volume image data.

10

7. The ultrasonic diagnostic imaging system of Claim 6, further comprising a multiplanar reformatter, responsive to the volume image data and the recognition of a plane of image data containing the desired anatomy by the neural network model, which is adapted to produce an image plane of image data containing the desired anatomy from the volume image data.

15

8. The ultrasonic diagnostic imaging system of Claim 3, wherein the system is further responsive to the extraction of an image of desired anatomy by the neural network model and adapted to produce a measurement of the desired anatomy.

20

25

9. The ultrasonic diagnostic imaging system of Claim 3, wherein the desired anatomy is a fetal bone; wherein the image of the desired anatomy is an image of the fetal bone; and

30

wherein the display is further adapted to display a measurement of the fetal bone.

10. The ultrasonic diagnostic imaging system of Claim 9, wherein the system is further adapted to use the measurement of the fetal bone in a fetal age

35

estimation.

11. The ultrasonic diagnostic imaging system of Claim 1, wherein the extracted image further
5 comprises a standard view of the desired anatomy.

12. A method of producing a desired view of desired anatomy during ultrasound imaging comprising:
acquiring volume image data which includes image
10 data of the desired anatomy;
displaying an image from the volume image data which includes at least a portion of the desired anatomy on a touchscreen display;
touching the at least a portion of the desired
15 anatomy on the touchscreen display;
in response to the touching, extracting a desired image of the desired anatomy from the volume image data; and
displaying the extracted image of the desired
20 anatomy.

13. The method of Claim 12, wherein the extracting is performed using a neural net model.

25 14. The method of Claim 12, wherein the extracting is performed using a fetal model.

15. The method of Claim 12, wherein the desired image further comprises a planar image of the desired
30 anatomy.

16. The method of Claim 12, wherein the desired image further comprises a standard view of the
desired anatomy.

35

1/7

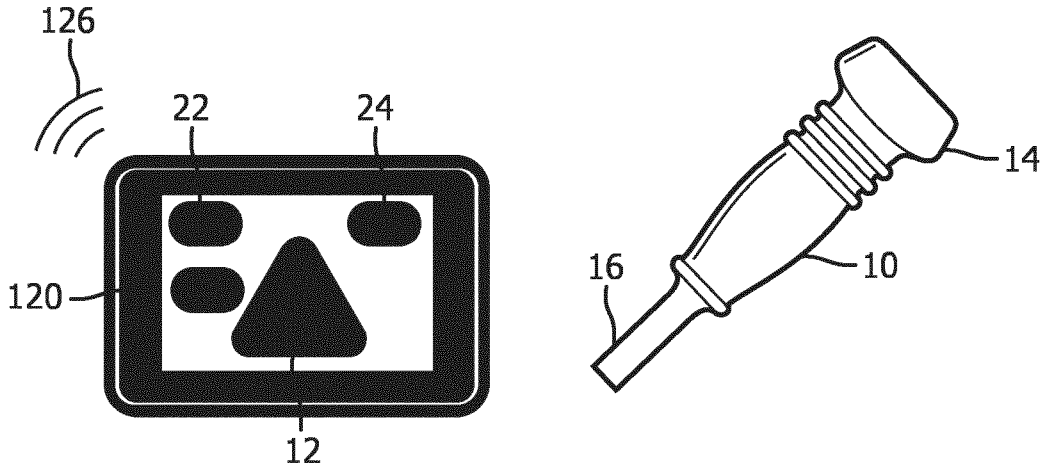

FIG. 1

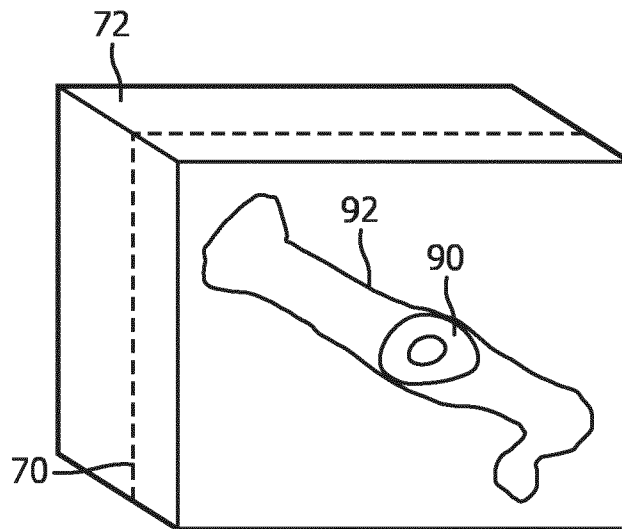

FIG. 2

2/7

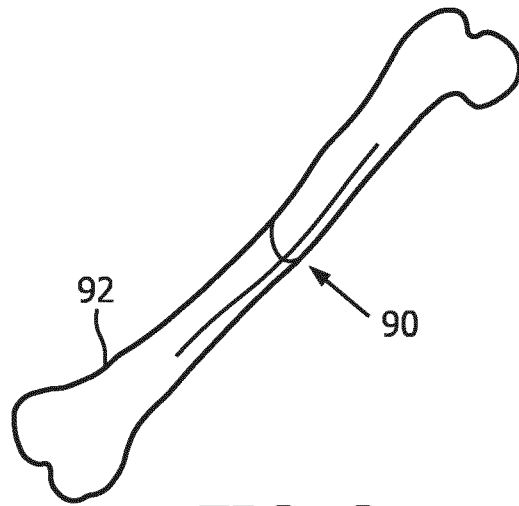

FIG. 3

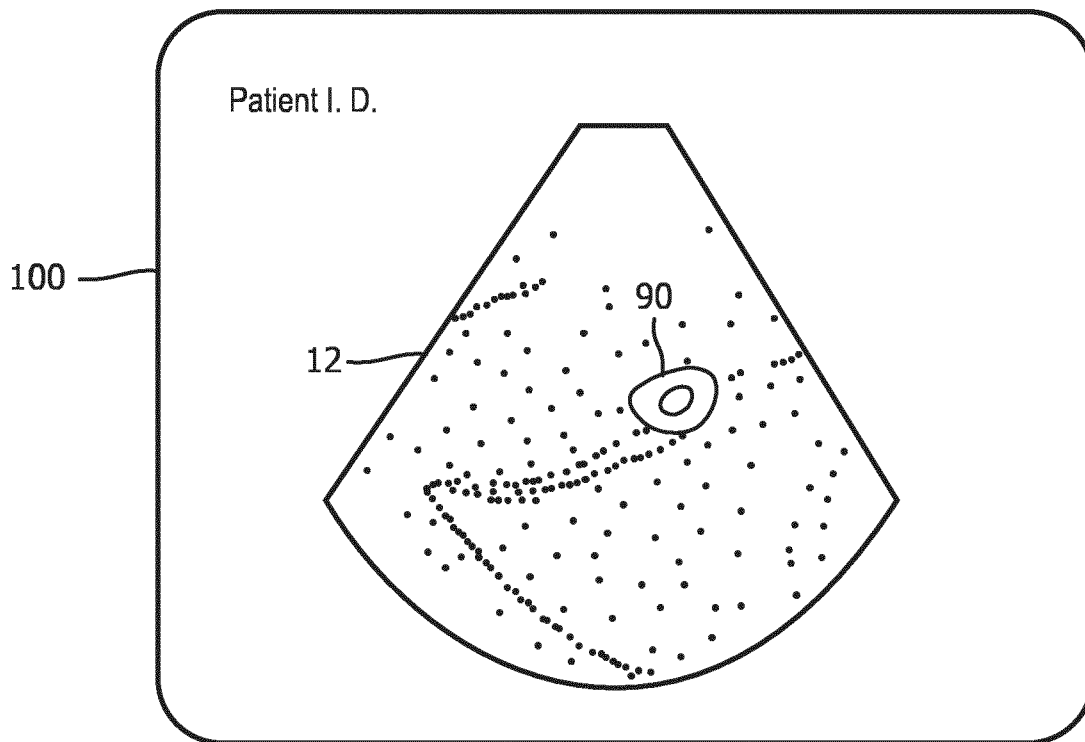

FIG. 4

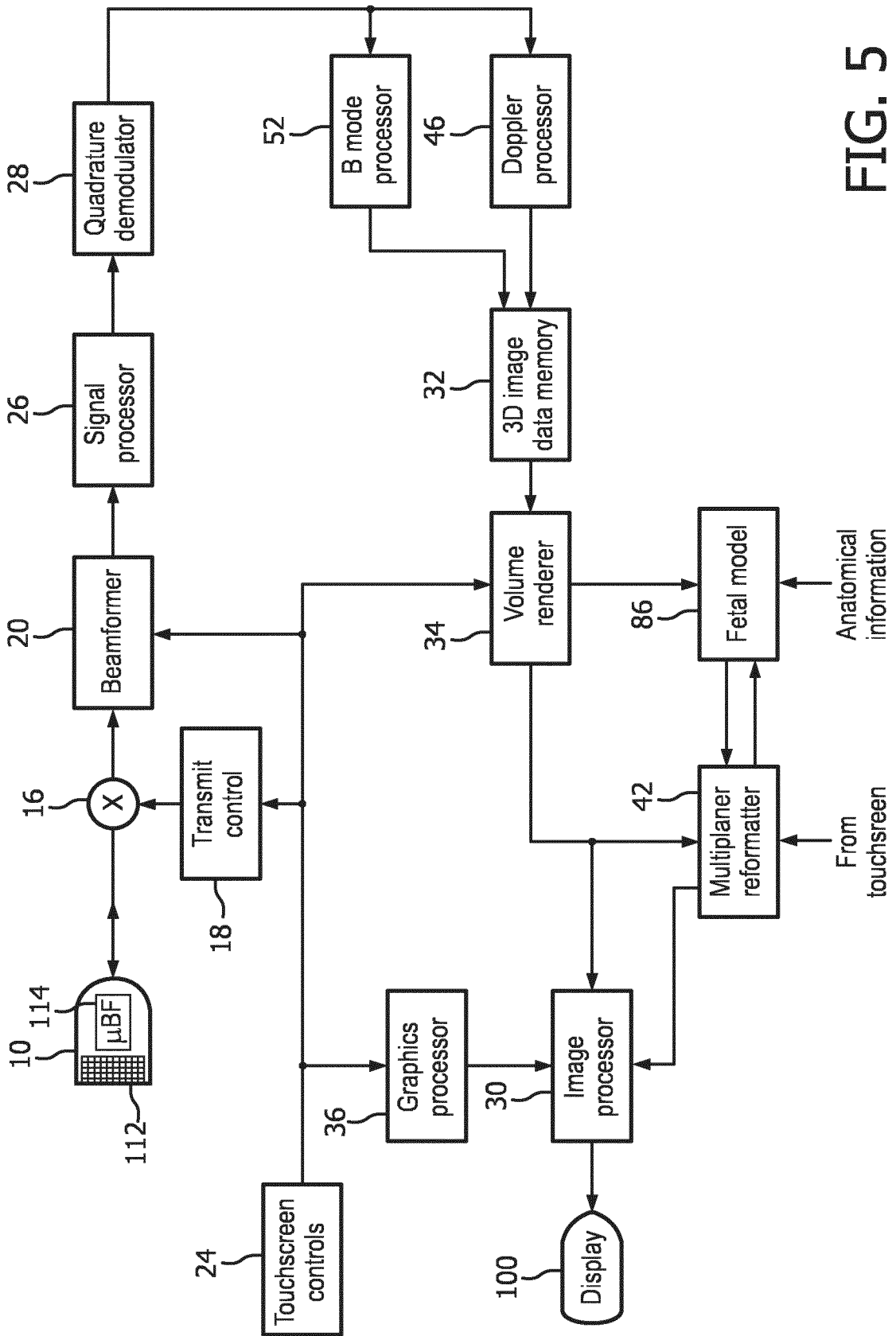

FIG. 5

4/7

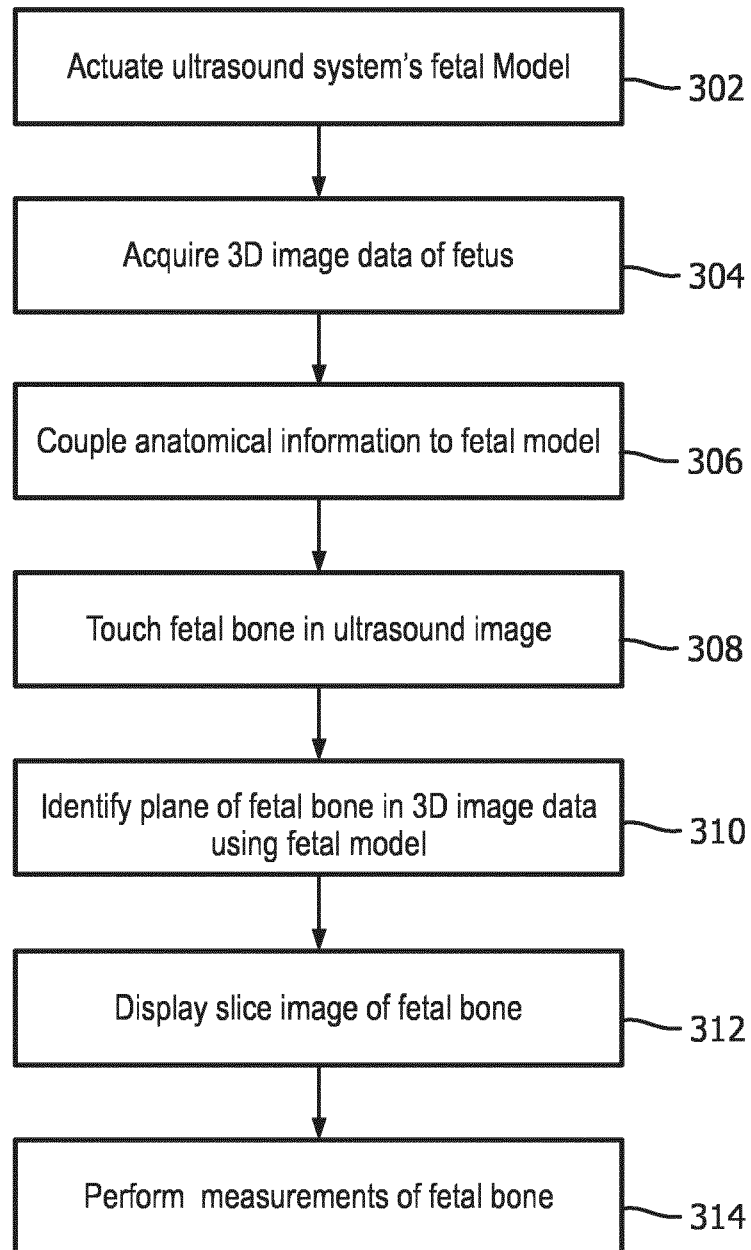

FIG. 6

5/7

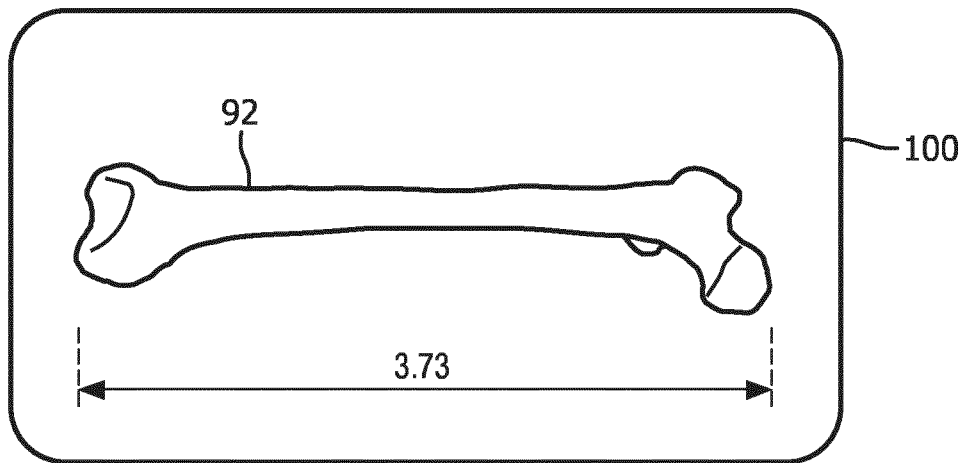

FIG. 7

6/7

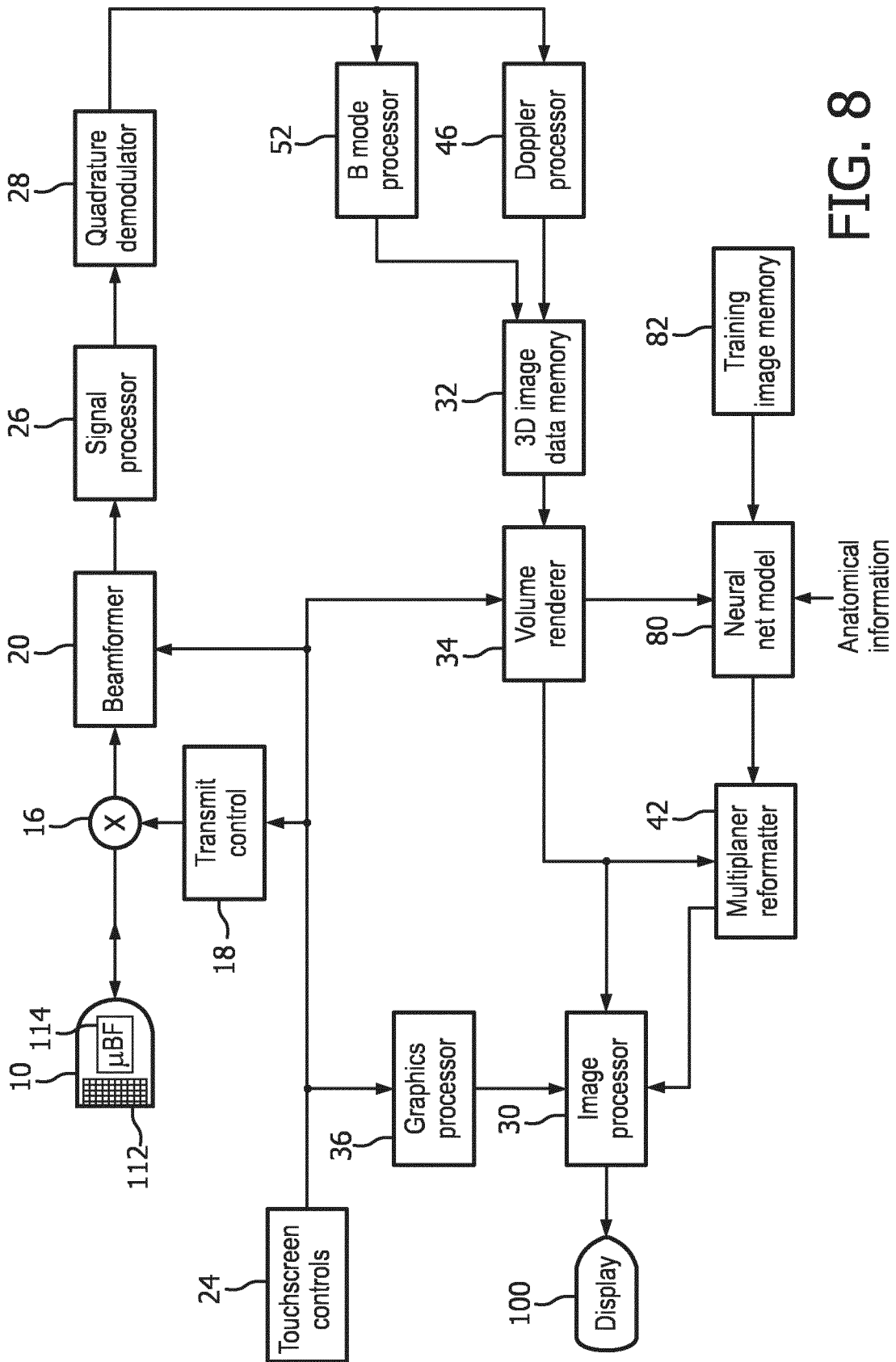

FIG. 8

7/7

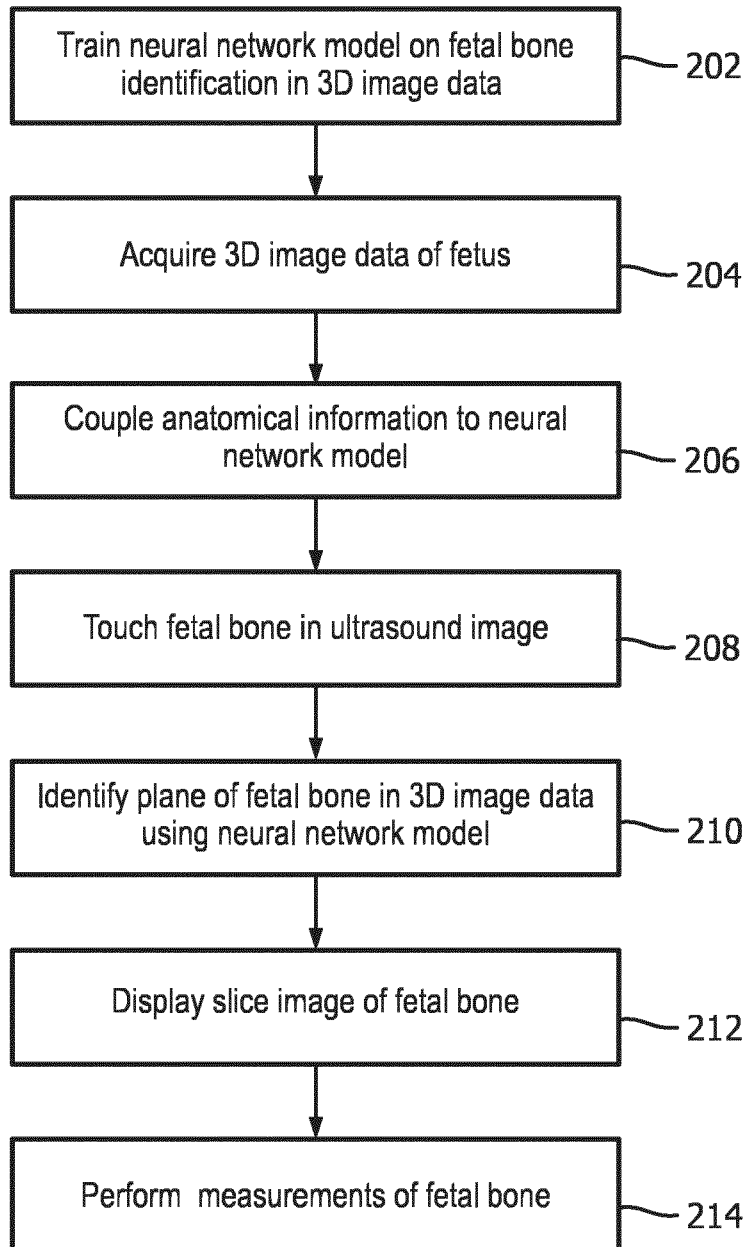

FIG. 9

INTERNATIONAL SEARCH REPORT

International application No
PCT/EP2018/071721

A. CLASSIFICATION OF SUBJECT MATTER
INV. A61B8/08 A61B8/00
ADD.
According to International Patent Classification (IPC) or to both national classification and IPC

B. FIELDS SEARCHED
Minimum documentation searched (classification system followed by classification symbols)
A61B

Documentation searched other than minimum documentation to the extent that such documents are included in the fields searched

Electronic data base consulted during the international search (name of data base and, where practicable, search terms used)
EPO-Internal, WPI Data

C. DOCUMENTS CONSIDERED TO BE RELEVANT

Category*	Citation of document, with indication, where appropriate, of the relevant passages	Relevant to claim No.
X	EP 3 115 000 A1 (SAMSUNG MEDISON CO LTD [KR]) 11 January 2017 (2017-01-11) the whole document	1-16
A	EP 2 434 454 A2 (SIEMENS CORP [US]; SIEMENS MEDICAL SOLUTIONS [US]) 28 March 2012 (2012-03-28) paragraph [0041] - paragraph [0042]	1-16
A	KR 2017 0054982 A (SAMSUNG MEDISON CO LTD [KR]) 18 May 2017 (2017-05-18) the whole document	1-16
A	EP 2 982 306 A1 (SAMSUNG MEDISON CO LTD [KR]) 10 February 2016 (2016-02-10) the whole document	1-16
	----- -/--	

Further documents are listed in the continuation of Box C.

See patent family annex.

* Special categories of cited documents :

- "A" document defining the general state of the art which is not considered to be of particular relevance
- "E" earlier application or patent but published on or after the international filing date
- "L" document which may throw doubts on priority claim(s) or which is cited to establish the publication date of another citation or other special reason (as specified)
- "O" document referring to an oral disclosure, use, exhibition or other means
- "P" document published prior to the international filing date but later than the priority date claimed

- "T" later document published after the international filing date or priority date and not in conflict with the application but cited to understand the principle or theory underlying the invention
- "X" document of particular relevance; the claimed invention cannot be considered novel or cannot be considered to involve an inventive step when the document is taken alone
- "Y" document of particular relevance; the claimed invention cannot be considered to involve an inventive step when the document is combined with one or more other such documents, such combination being obvious to a person skilled in the art
- "&" document member of the same patent family

Date of the actual completion of the international search 8 November 2018	Date of mailing of the international search report 16/11/2018
Name and mailing address of the ISA/ European Patent Office, P.B. 5818 Patentlaan 2 NL - 2280 HV Rijswijk Tel. (+31-70) 340-2040, Fax: (+31-70) 340-3016	Authorized officer Mundakapadam, S

INTERNATIONAL SEARCH REPORT

International application No
PCT/EP2018/071721

C(Continuation). DOCUMENTS CONSIDERED TO BE RELEVANT

Category*	Citation of document, with indication, where appropriate, of the relevant passages	Relevant to claim No.
A	EP 2 965 693 A1 (SAMSUNG MEDISON CO LTD [KR]) 13 January 2016 (2016-01-13) the whole document	1-16
A	----- NIKOONAHAD M ET AL: "MEDICAL ULTRASOUND IMAGING USING NEURAL NETWORKS", ELECTRONICS LETTERS, IEE STEVENAGE, GB, vol. 26, no. 8, 14 April 1990 (1990-04-14) , page 545/546, XP000120906, ISSN: 0013-5194 the whole document -----	1-16

INTERNATIONAL SEARCH REPORT

Information on patent family members

International application No PCT/EP2018/071721

Patent document cited in search report	Publication date	Patent family member(s)	Publication date	
EP 3115000	A1	11-01-2017	EP 3115000 A1	11-01-2017
			KR 20170006946 A	18-01-2017
			US 2017007209 A1	12-01-2017

EP 2434454	A2	28-03-2012	EP 2434454 A2	28-03-2012
			US 2012078097 A1	29-03-2012

KR 20170054982	A	18-05-2017	CN 107913082 A	17-04-2018
			KR 20170054982 A	18-05-2017

EP 2982306	A1	10-02-2016	EP 2982306 A1	10-02-2016
			KR 20160016467 A	15-02-2016
			US 2016038122 A1	11-02-2016

EP 2965693	A1	13-01-2016	EP 2965693 A1	13-01-2016
			KR 20160007096 A	20-01-2016
			US 2016014344 A1	14-01-2016

专利名称(译)	能够通过触摸图像交互从体积数据中提取图像计划的超声系统		
公开(公告)号	EP3668408A1	公开(公告)日	2020-06-24
申请号	EP2018759572	申请日	2018-08-10
[标]申请(专利权)人(译)	皇家飞利浦电子股份有限公司		
申请(专利权)人(译)	皇家飞利浦N.V.		
当前申请(专利权)人(译)	皇家飞利浦N.V.		
[标]发明人	ROUNDHILL DAVID NIGEL		
发明人	ROUNDHILL, DAVID NIGEL		
IPC分类号	A61B8/08 A61B8/00		
CPC分类号	A61B8/08 A61B8/0866 A61B8/0875 A61B8/4427 A61B8/4472 A61B8/465 A61B8/466 A61B8/467 A61B8/469 A61B8/483 A61B8/5223 A61B8/523 A61B8/585 G16H50/30 A61B8/13 G06T7/0012 G06T17/10 G06T2207/10136 G06T2207/30008		
代理机构(译)	飞利浦知识产权及标准		
优先权	62/546590 2017-08-17 US		
外部链接	Espacenet		

摘要(译)

超声系统包括图像提取处理器，该图像提取处理器响应于触摸屏显示器上的超声图像中的至少一部分期望的解剖结构的触摸，以从包括期望的解剖结构的3D体积数据集中提取期望的解剖结构的图像。该系统和方法还可以用于从解剖学的体积图像数据提取标准视图图像。