



(12) **EUROPEAN PATENT APPLICATION**

(43) Date of publication:  
**19.09.2018 Bulletin 2018/38**

(51) Int Cl.:  
**G01S 7/52 (2006.01)**      **G01S 15/89 (2006.01)**  
**A61B 8/00 (2006.01)**      **A61B 8/02 (2006.01)**  
**A61B 8/06 (2006.01)**      **A61B 8/08 (2006.01)**  
**A61B 8/12 (2006.01)**      **A61B 8/14 (2006.01)**  
**G10K 11/34 (2006.01)**

(21) Application number: **17196129.5**

(22) Date of filing: **22.06.2007**

(84) Designated Contracting States:  
**AT BE BG CH CY CZ DE DK EE ES FI FR GB GR HU IE IS IT LI LT LU LV MC MT NL PL PT RO SE SI SK TR**

- **BRODSKY, Michael**  
**Brookline, MA 02445 (US)**
- **HE, Xingbai**  
**Belmont, MA 02478 (US)**
- **WONG, William M**  
**Milton, MA 02186 (US)**

(30) Priority: **23.06.2006 US 474098**

(62) Document number(s) of the earlier application(s) in accordance with Art. 76 EPC:  
**07809792.0 / 2 037 814**

(74) Representative: **Graham Watt & Co LLP**  
**St. Botolph's House**  
**7-9 St. Botolph's Road**  
**Sevenoaks TN13 3AJ (GB)**

(71) Applicant: **Teratech Corporation**  
**Burlington, MA 01803 (US)**

Remarks:

This application was filed on 12-10-2017 as a divisional application to the application mentioned under INID code 62.

(72) Inventors:  
 • **CHIANG, Alice M**  
**Weston, MA 02493 (US)**

(54) **ULTRASOUND 3D IMAGING SYSTEM**

(57) The present invention relates to an ultrasound imaging system in which the scan head either includes a beamformer circuit that performs far field subarray beamforming or includes a sparse array selecting circuit

that actuates selected elements. When used with second stage beamforming system, three dimensional ultrasound images can be generated.

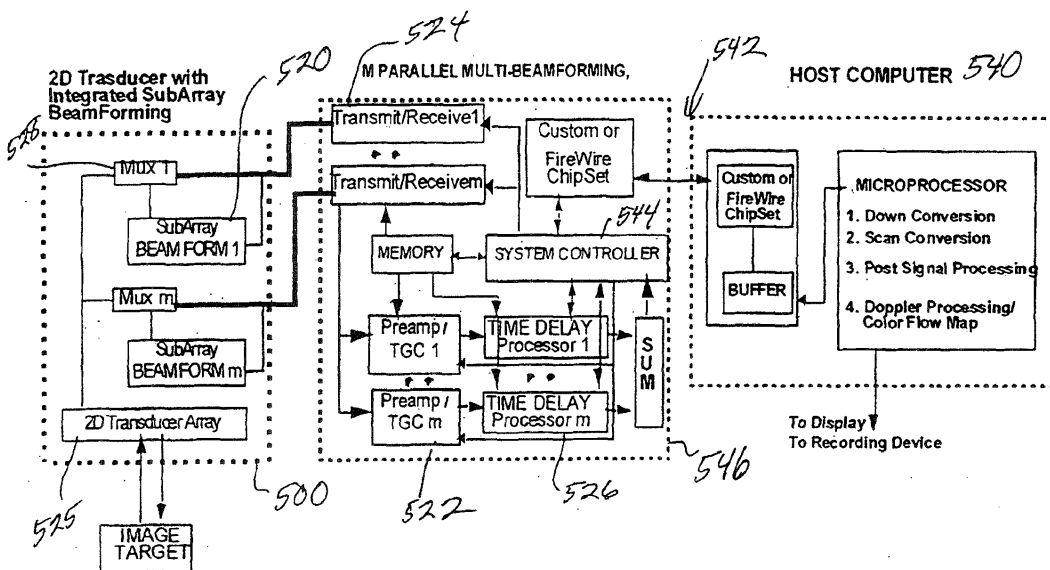


Figure 4

**Description**

## CROSS REFERENCE TO RELATED APPLICATIONS

5 **[0001]** This is a continuation-in-part of U.S. Application No. 11/474,098 filed on June 23, 2006, the entire contents of which is incorporated herein by reference.

## BACKGROUND OF THE INVENTION

10 **[0002]** Medical ultrasound imaging has become an industry standard for many medical imaging applications. Techniques have been developed to provide three dimensional (3D) images of internal organs and processes using a two dimensional (2D) transducer array. These systems require thousands of beamforming channels. The power required to operate such systems has resulted in the use of an analog phase shift technique with a digital delay beamformer that results in a compromise of image quality.

15 **[0003]** There is a continuing need for further improvements in ultrasound imaging technologies enabling improved real-time three dimensional imaging capability. In addition, this improved capability should support continuous real-time display for a fourth dimensional 4D function.

## SUMMARY OF THE INVENTION

20 **[0004]** The present invention relates to a system for ultrasound medical imaging that provides three dimensional (3D) imaging using a two dimensional (2D) array of transducer elements in a probe housing. Embodiments of the invention provide systems and methods for medical imaging having high resolution and numerous imaging modalities.

25 **[0005]** In a preferred embodiment, the probe housing contains a first beamforming circuit that transmits beamformed data to a second housing having a second beamforming circuit. The first beamforming circuit provides a far-field subarray beamforming operation. The resulting beamformed data is transmitted from the scan head to a second housing having the second beamforming circuit that provides near-field beamsteering and beamfocusing.

30 **[0006]** A preferred embodiment provides a scan head that can be connected to a conventional ultrasound system in which the scan head provides the inputs to the conventional beamforming processing function. The scan head beamformer can utilize a low power charge domain processor having at least 32 beamforming channels.

35 **[0007]** A preferred embodiment of the invention employs a sparse array where only a fraction of the transducer elements need to be activated. By selecting the four corner elements of the array to provide proper main lobe bandwidth, minimizing average sidelobe energy and clutter, eliminating periodicity and maximizing peak to side lobe ratio, quality images are produced. To steer the beams across the volume or region of interest, different transducer elements must be actuated in proper sequence to maintain the peak to sidelobe ratio. The system processor can be programmed to provide the desired sequence for transducer actuation to direct the beam at different angles. Alternatively, a discrete controller can be used to control sparse array actuation. A preferred embodiment provides a scan head with integrated switching circuits for sequentially selecting sparse array actuation elements for sequential multiple beamforming. The scan head can be connected to a conventional ultrasound system in which the scan head provides the inputs to the conventional beamforming processing functions. In another embodiment, the transmit array elements and receive array elements can be operated independently with the transmit elements comprising a sparse array and the receive elements being a near fully populated array. In a preferred embodiment, the multiplexer and beamformer circuits can be integrated into an interface system, or alternatively, into a host processing system, leaving a 2D transducer array mounted in the probe housing.

45 **[0008]** In addition to the three dimensional (3D) display capability, a fourth dimension or time resolved image display can be used to record and display a sequence of images recorded at 10 frames per second or higher, for example. This enables viewing of rapidly changing features such as blood or fluid flow; heart wall movement etc. at video frames rates of 30 frames per second.

## 50 BRIEF DESCRIPTION OF THE DRAWINGS

**[0009]**

55 Fig. 1 illustrates the use of a two dimensional tiled array for ultrasound imaging in accordance with the invention.  
 Fig. 2 illustrates a steerable two dimensional array in accordance with the invention.  
 Fig. 3A illustrates the use of a first beamformer device for far field beamsteering and focusing and a second time delay beamformer for near field beamforming.  
 Fig. 3B illustrates a first analog subarray beamformer forwarding data to a digital beamformer near field beamformer.

Fig. 4 illustrates a preferred embodiment of a three dimensional imaging system in accordance with the integrated Subarray scan head invention.

Fig. 5 illustrates a preferred embodiment of the integrated Subarray scan head invention using a charge domain processor for the 2<sup>nd</sup> time delay beamforming.

Fig. 6A illustrates the use of the integrated subarray scan head probe of the present invention with a second stage beamforming ultrasound processor.

Fig. 6B illustrates use of the integrated Subarray scan head with a digital beamforming processor.

Fig. 7 illustrates an ultrasound system in accordance with the invention.

Fig. 8A illustrates a sparse array used in accordance with the invention.

Fig. 8B graphically illustrates the sparse array performance.

Fig. 9A illustrates the use of the integrated sparse array scan head probe of the present invention connected to a host system with charge-domain beamforming processing.

Fig. 9B illustrates the use of the integrated sparse array scan head probe of the present invention connected to a conventional digital ultrasound system with m-parallel beamforming components.

Fig. 10 illustrates a scan head connected to a portable computer in accordance with a preferred embodiment of the invention.

Fig. 11 illustrates a near fully populated receive array in which the receiving elements are independent of, and do not overlap, the transmit array.

Fig. 12 graphically illustrates the azimuth and elevation cross-sections of the receive array beampattern.

Fig. 13 is a magnified portion of the azimuthal beampattern of Fig. 12 showing the mainlobe and sidelobe structure.

Fig. 14 illustrates a near fully populated receive array beampattern.

Fig. 15 shows selected transmit locations for a sparse array in accordance with the invention.

Fig. 16 illustrates a cross-sectional view of the transmit sparse array beampattern of the embodiment in Fig. 15.

Fig. 17 illustrates a sparse transmit array beampattern.

Fig. 18 illustrates that it is possible to limit average sidelobe energy to less than -35dB relative to the central peak of the beampattern.

#### DETAILED DESCRIPTION OF THE INVENTION

**[0010]** The objective of the beamforming system is to focus signals received from an image point onto a transducer array. By inserting proper delays in a beamformer to wavefronts that are propagating in a particular direction, signals arriving from the direction of interest are added coherently, while those from other directions do not add coherently or cancel. For real-time three-dimensional applications, separate electronic circuitry is necessary for each transducer element. Using conventional implementations, the resulting electronics rapidly become both bulky and costly as the number of elements increases. Traditionally, the cost, size, complexity and power requirements of a high-resolution beamformer have been avoided by "work-around" system approaches. For real-time three-dimensional high-resolution ultrasound imaging applications, an electronically steerable two-dimensional beamforming processor based on a delay-and-sum computing algorithm is chosen.

**[0011]** The concept of an electronically-adjustable acoustic conformal lens is to divide the surface of a 2D transducer array into plane "tiles" of relatively small subarrays. As described in U.S. 6,292,433 the entire contents of which incorporated herein by reference, and illustrated in Fig. 1 the tiles/subarrays 120 are made small enough so that when an object is placed within the field-of-view of the imaging system, the incident radiation 122 from the object toward each "tile" can be treated using a far-field approximation. Additional delay elements are incorporated as second-stage processing to allow all subarrays to be coherently summed (i.e., global near-field beamforming can be achieved by simply delaying and then summing the outputs from all subarrays.) The delay-and-sum beamformer allows each subarray to "look" for signals radiating from a particular direction. By adjusting the delays associated with each element of the array, the array's look direction can be electronically steered toward the source of radiation. Thus instead of looking in one direction as seen at 124a, the direction of tiles 120 can be steered in different direction 124b. The delay line requirement for each element in the sub-array can be less than a hundred stages. Only long delays for global summing are needed for the final near field focusing.

**[0012]** To scan an image plane using a steerable beamformer system a process such as that shown in Fig. 2 can be used. A raster scan 260 can be used to scan an image plane 262 using a 2D steerable transducer array 264.

**[0013]** A detailed diagram of an electronically-controlled beamforming system in accordance with the invention is shown in Fig. 3A. This system consists of a bank of parallel time-delay beamforming processors 330, -330N. Each processor 330 consists of two components: a 2D sub-array beamformer 332 for far-field beamsteering/focusing and an additional time delay processor 334 to allow hierarchical near-field beamforming of outputs from each corresponding subarray. The sub-arrays 332 include m-programmable delay lines 340 with tap selectors 342, multiplexers 344 and summed 346 output. As can be seen in Fig. 3A, for a system with n-sub-arrays, n-parallel programmable 2<sup>nd</sup>-stage near

field time delays are needed for individual delay adjustment which are converted with A/D converter 352 to allow all n-parallel outputs be summed 354 coherently, in turn, this summed output is filtered 338 and provides the 3D images of the targeted object. A processor 336 controls sub-array operation. Use of the scan head with a second stage digital beamformer is shown in Fig. 3B. In this embodiment, a plurality of N sub-array beamformers 400 each receive signals from m transducer elements that have separate delay lines whose outputs are summed and provided to near-field beamformers 420 so that this beamformer can be a conventional system with conventional processor 480. A separate sub-array processor 460 controls beamformers 400.

**[0014]** Without using this hierarchical subarray far-field and then near-field beamforming approach, for an 80 x 80 element 2D array, a cable consisting of six thousand and four hundred wires is needed to connect the transducer array to a conventional beamforming system. As shown in Fig. 3A, the number of inputs to each subarray processor equals the total number of delay elements in the subarray, each sub-array only has a single output. The number of inputs to the subarray bank equals the number of 2D array elements, and the number of outputs from the subarray bank equals to the total transducer array element number divided by the subarray element number, i.e., the number of outputs from the subarray bank reference to the number of inputs is reduced by a factor equal to the size of the subarray. For example, if one selects to use a 5x5 subarray to implement this hierarchical beamforming concept, after the first stage subarray beamforming, the total number of wires needed to connect to the 2<sup>nd</sup> stage near-field beamforming is reduced by a factor of 25. More specifically, as mentioned above, without using this 2D subarray beamforming, 6400 wires are needed to connect an 80 x 80 element 2D transducer array to a conventional back-end beamforming system. Using a 5 x 5 subarray processing bank first, the number of wires required to connect to the backend beamforming system is reduced to 256. Based on the current invention, a bank of 256 5 x 5 element subarrays Beamformer can be integrated with a 80 x 80 element 2D array in the scan head, so a cable consisting of 256 wires is adequate to connect the integrated scan head with the back-end near-field beamforming system. It is important to note that 5 x 5 subarray far-field beamforming processors can be easily integrated in a small size Si integration circuit, eight of such 5 x 5 subarray beamforming can be integrated on one chip. Only 32 chips integrated into the scan head, it can reduce the cable size from 6,400 wires down to 256 wires.

**[0015]** A preferred embodiment of the invention for a 2D array beamforming, each minimizing noise and cable loss with improved S/N performance, are described in Fig. 4, 5 and 6. In all three implementations, the bank of m parallel subarray beamforming processors 520 and multiplexers 528 are integrated with the 2D transducer array 525 to create a compact, low-noise, scan head 500. Fig. 4 depicts a system that the compact scan head is connected to a dedicated processing module, in which the m-parallel preamp/TGCs 522 transmit/received chips 524 and the 2<sup>nd</sup> stage time delay processing units 526 are housed. This dedicated processing module communicates with a host computer 540 via FireWire IEEE 1394 or USB or PCI bus 542. Control and synchronization is performed by the system controller 544 located in the processing module or housing 546. Fig. 5 depicts the same architecture as stated in Fig. 4, except, inside the dedicated processing module, the 2<sup>nd</sup> stage time delay processing units are specifically implemented by using charge-domain programmable (CDP) time-delay lines 600 in housing 620 that is connected to handheld probe 660 and computer housing 648. Fig. 6B depicts a system that the compact sparse array scan head 700 is connected to a conventional, commercially available time-domain digital ultrasound imaging system 700 with n-parallel beamforming channels 760. It is easy to see that in Fig. 6A, the time-delay processor 720 can also be implemented by using CDP time-delay lines 740. In these embodiments the near-field beamforming is housed 720, 780 in the same housing with other image processing functions.

**[0016]** By systematically varying beamformer delays and shading along a viewing angle of a 2D transducer array, returned echoes along the line of sight representing the 3D radiation sources can be used to create the scanned image at the scanned angle. The system can provide continuous real-time large area scanned images throughout a large field of view at 20 frames/s or more. At this frame rate, the system can be used to display continuous 3D images vs. time, thus providing 4D information of the scanned object. As shown in Fig. 7 a CDP beamforming chip 810, a time multiplexed computing structure can be used to generate multiple beams, i.e., for each transmit pulse, the bank of 2D subarray beamformers 818 and its corresponding 2<sup>nd</sup> stage near-field time-delay line are capable of providing multiple beams sequentially. The computing circuits sequentially generate the delays required for forming K beams. The device operates as follows. Once a set of sampled returned-echoes are loaded in the delay lines with sampling circuits 814, at time  $t_1$ , the delays required for forming beam 1 are computed 812 within each module 822 and applied in parallel to all delay lines. The sampled return-echoes with proper delays are coherently summed 802 and filtered 804 to form the first beam. At time  $t_2$ , the delays required for forming beam 2 are computed within each module and applied in parallel to all delay lines. The sampled return-echoes with proper delays are coherently summed to form the second beam. The procedure repeats until the Kth beam is coherently formed.

**[0017]** For example, if a computing circuit with 16-serial addressable outputs is built in with the CDP subarray and the 2<sup>nd</sup> stage time delay lines, for each transmit pulse, 16 beams or scan lines each along a different scan angle can be created. For 256-pulses with a down-range depth of 15cm, the system can generate a 4096-beams with a 64 x 64 pixel resolution at a frame rate of 20 frames/s. The system is fully programmable; the beamforming electronics can be adjusted

to zoom-in to a smaller field-of-view for high-resolution or higher frame rate images. For example, using 192-transmit pulses with the same down-range depth of 15 cm, the system can generate a 3072-beams with a 64 x 48 pixel resolution at a 30 frame/s frame rate.

**[0018]** The array described addresses ultrasound imaging applications using a two-dimensional 2 cm x 2 cm array at a frequency of 3 MHz. The need for resolution on the order of less than half the wavelength dictates as large an aperture as possible that can be housed within a compact package. To interrogate a 90 degree scanning volume and also minimize the impact of grating lobes, an element pitch or separation of less than 0.25 mm is desirable, leading to a 80 x 80 element array. Using the subarray processing technique described above, a scan head with integrated subarray beamforming circuits followed by a 2<sup>nd</sup> stage near-field beamsteering/beamfocusing system provides a practical implementation. However, the implementation still requires at least 32 subarray chips to be integrated on a scan head. An alternative pseudo random array design approach can be used to achieve this resolution with a much less amount of processing components in the scanned head.

**[0019]** To make a sparse array practical, the combination of low insertion loss and wide bandwidth performance is important for realizing acceptable imaging performance with low illumination levels. Quarter-wave matching layers with low acoustic impedance, but physically solid backing results in a robust array that loses only 3-4 dB in the conversion of received signal energy to electrical energy. Array band-widths of 75% or more are typical of this design and construction process. Also, the transducer array employs element positioning and an interconnect system suitable for the beamformer circuitry. The electronics are mounted on printed-circuit boards that are attached to the transducer elements via flexible cables. In practice, a majority of the array elements are connected to outputs using the flexible cables. However, only a small fraction of the total number of elements are wired to the circuit boards. Nevertheless, the large number of array element connections are sufficient to insure a unique pattern of active-element locations in the final array.

**[0020]** As an example of a sparse array, assuming a 2 x 2 cm array with 256 active elements, the resulting filling factor is 4%. The output signal to noise ratio of the array is proportional to the number of active elements, so this filling factor corresponds to a loss in sensitivity of -13 dB when compared to a filled array of the same dimensions. To compensate for this loss, a transmitted signal of wider bandwidth is chosen to increase array sensitivity. In the approach presented here, the sensitivity is increased on the order of 10 dB. Further details regarding sparse array devices can be found in U.S. Patent No. 6,721,235, the contents of which is incorporated herein by reference.

**[0021]** Positioning the elements of the array follows the approach in which care must be taken to eliminate any periodicity that would produce grating lobes that compete with the main lobe. Pseudorandom or random arrays can be used (FIG. 8A). The geometry of activated element placement has been developed to maximize the efficiency of the beamformers while minimizing grating and side lobe clutter. Switching between a plurality of different array patterns is used to provide the most efficient beam pattern at different beam angles relative to the region or volume of interest being scanned. Thus, a first pattern can utilize that illustrated in Fig. 8A, which is then switched to a second pattern for a different scan angle. This can involve selecting a transducer element within a neighborhood 880 surrounding a given element to scan at a second angle.

**[0022]** The primary goal of the optimization method is to minimize the average side lobe energy. Specifically, this is done by interactively evaluating the optimization criterion:

$$J = \frac{1}{2u_{max}^2} \int \int W(u_x, u_y) B(u_x, u_y) du_x du_y, \quad (1)$$

where the weighting function,  $W(u_x, u_y)$ , applies more weight to regions in the array response that require side lobe reduction. The optimization method begins with no weighting (i.e.,  $W(u_x, u_y)=1$ ) and proceeds by choosing successively better weighting functions that satisfy the optimization criterion. Since the side lobes that require the greatest reduction are related to the previously computed beampattern,  $B(u_x, u_y)$ , the weighting is chosen such that  $W(u_x, u_y) = B(u_x, u_y)$ . This is done in an interactive manner until convergence.

**[0023]** Basically, a random array is capable of producing an imaging point spread function that has a main lobe to average side lobe ratio of N, where N is the total number of active elements in the array. For the 256-element sparse array example, the resulting ratio is -13 dB. Using a wide bandwidth approach improves this ratio by 10 dB. Based on the preceding optimization criterion, a pseudorandom placement of the array elements was generated (FIG. 8A).

**[0024]** FIG. 8B is a plot of the array performance, sensitivity versus cross range, for a 256-element sparsely-sampled array at 3 MHz. The peak to maximum side lobe level is approximately 30 dB. To improve this performance, the system is configured to achieve the maximum main lobe to clutter level ratio possible, which has been independently verified.

**[0025]** FIG. 9B depicts a system that the sparse array scan head 900 is connected to a conventional, commercially available time-domain digital ultrasound imaging system 940 with m-parallel beamforming channels. It is easy to see that in Fig. 9A, the time-delay processor can also be implemented by using CDP time-delay lines 920 in housing 925 that is connected to a separate computer 927. An array of m multiplexers 906 is used to switch between a sequence of

scan patterns executed using a software program and system controller 940 or processor 950. The sequence of sparse array patterns is thus selected to scan at different scan angles of an object being imaged to provide 3D ultrasound imaging thereof.

**[0026]** A commercially available window-based 3D visualization software can be used to visualizing, manipulating, and analyzing the 3D multiple-beams volume image data generated by the electronically-adjustable acoustic conformal lens system. Traditionally, a clinician with 2D ultrasound images for diagnosis would look at the 2D scanned images slice by slice and mentally reconstruct the information into a 3D representation to judge the anatomy of the patient. This procedure requires the clinician to have well-founded experience as well as a highly sophisticated understanding of human anatomy. To create a "complete" image to the 3D structures, the clinician has to take all available slices into account. Looking at hundreds of slices is too time-consuming, even for a single patient. 3D visualization based on 3D volume data can help overcome this problem by providing the clinician with a 3D representation of the patient's anatomy reconstructed from the set of multiple-scanned beamforming data.

**[0027]** A commercially available software tool such as KB-Vol3D of KB-VIS technologies, Chennai, India, provides display or viewing 3D features such as:

- Fast Volume-Rendering
- Shaded Surface Display

**[0028]** Shaded-Surface module allows easy visualization of surfaces in the volume. Surfaces may be created by intensity-based thresholding. Alternatively, the Seeding option allows selection of specific connected structures of interest.

- MIP (Maximum Intensity Projection) with Radials
- MPR (Multiple-Plane-Reformatting) with Oblique & Double-Oblique and 3D correlation
- MRP Slabs & Multi-Cuts
- Curved MPR
- Color & Opacity Presets with Editor
- Region-Growing and Volume Measurements
- Cutaway Viewing with Slab-Volume and Interactive Real-time VOI

**[0029]** Volume-interiors are easily visualized using the "Cutaway-Viewing" tool. A Cut-Plane is used to slice through the volume, revealing the interior regions. The cut-plane is easily positioned and oriented using the mouse.

**[0030]** The VOI (Volume-of-Interest) tool allows interactive, real-time Volume-of-Interest display. The user can isolate and view sub-volumes of interest very easily and in real-time, using easy click-and-drag mouse operation.

- Image Save in Multiple Formats

**[0031]** Images displayed by KB-Vol3D can be captured to various image formats (including DICOM, JPEG, and BMP etc.)

- Movie Capture in AVI Format

**[0032]** Visualization operations can also be captured to an AVI movie .le and played on Windows Media Player, QuickTime, and Real Player etc.

**[0033]** The invention can be implemented using a scan head 12 connected to a portable computer 14 as shown in Fig. 10. the ultrasound system 10 can also include a cable 16 to connect the probe 12 to the processor housing 14. Certain embodiments can employ an interface unit 13 which can include a beamformer device. Scan head 12 can include a transducer array 15A (2D) and a circuit housing 15B which can house multiplexer and/or beamforming components as described in detail in U.S. Patent Nos. 6,106,472 and 6,869,401, the entire contents of these patents being incorporated herein by reference.

**[0034]** A 2D array configuration using sparse-array for transmission and non-overlapped fully-populated array is used for receiving. For an N x M element array, only m-elements with optimized sparse array placement are used for transmission and then the remaining NM-m elements are used as the receiving array. For example, for a 40x60-element 2D array, 256-elements are used as transmit element, the placement of the transmit elements are optimized based on selection criteria, the remaining 2144 element are used as received elements. This embodiment simplifies the multiplexer requirement needed for a 2D array, in which case the multiplexer can be mounted in the interface housing.

**[0035]** An example of the element locations for the near fully-populated 40 by 60 receive array 50 is shown in Fig. 11. The 2400-element array is depopulated by the 256 sparse array transmit elements to yield 2144 receive element locations.

These elements are independent and do not overlap the sparse-array transmit elements. In a preferred embodiment the transmit elements constitute less than 25% of the total number of array elements, and preferably less than 15%.

**[0036]** The azimuth and elevation cross-sections of the beam pattern of the above mentioned receive array are shown in Fig. 12. The first sidelobe is approximately -13 dB relative to the central peak. The grating lobes are less than -30 dB relative to the peak. Given that the 2D array is wider than tall, the azimuthal beamwidth (plotted in blue (solid)) is slightly narrower than the elevation beamwidth (plotted in green (dotted)).

**[0037]** In Fig. 13, a magnifying view of the above mentioned azimuthal beam pattern demonstrates the detailed mainlobe and sidelobe structure. For this case, the beamwidth is approximately 1.5 degrees. The beam pattern is nearly identical to the fully populated 60x40 element beam pattern. The receive array beam pattern is shown in Fig. 14. As stated above, the received sparse array is comprised of a 2144 elements. There are no sidelobes due to depopulating the center of the array by 256 (transmit) elements.

**[0038]** An example of the final element locations for the 256 transmit sparse array 60 are shown in Fig. 15. The 256 element locations are confined to the central 32x32 elements of the fully populated array. These elements are independent and do not overlap the receive array elements. A cross sectional view of the transmit sparse array beam pattern is shown in Fig. 16. The first sidelobe is approximately -17 dB relative to the central peak. The grating lobes are less than -27 dB relative to the peak. The sparse array optimization algorithm minimizes the sidelobe energy +/- 45 degrees in elevation and +/- 45 degrees in elevation.

**[0039]** Fig. 17 demonstrates the beam pattern of the sparse transmit array shown in Fig. 15. The transmit beam pattern is designed to uniformly cover a 4x4 beam data pyramid. The transmit sparse array is comprised of a 256-element subset of the fully populated 2400-element array (approximately 10% fill). The placement of the transmit/receive array design algorithm required over 750 iterations to minimize the transmit and receive sidelobe energy within the +/- 45 degree azimuth, +/- 45 degree elevation region. As shown in Fig. 18, after 750 iterations, the final sparse transmit-array element locations limit the average sidelobe energy to less than -35 dB relative to the central peak of the beam pattern.

**[0040]** The claims should not be read as limited to the recited order or elements unless stated to that effect. All embodiments that come within the scope and spirit of the following claims and equivalents thereto are claimed as the invention.

**[0041]** Embodiments of the present invention may include the features of the following enumerated paragraphs.

1. A medical ultrasound imaging system comprising:

a two dimensional array of transducer elements in a probe housing;  
 a first beamformer device in the probe housing;  
 a second beamformer device in a second housing, the second beamformer being in communication with the probe housing to receive beamformed data from the first beamformer device.

2. The system of paragraph 1 wherein the first beamformer device comprises a plurality of beamformer elements and a corresponding plurality of multiplexer elements.

3. The system of paragraph 1 further comprising a processor housing having an image processor programmed to perform 3D imaging Processing and Doppler processing.

4. The system of paragraph 3 wherein the second housing is connected to the probe housing with a first cable and is connected to the processor housing with a second cable.

5. The system of paragraph 1 wherein the two dimensional array has at least 256 elements.

6. The system of paragraph 1 wherein the first beamformer device comprises a plurality of sub-array beamforming channels.

7. The system of paragraph 1 wherein the second beamformer device comprises a digital beamformer.

8. The system of paragraph 1 wherein the first beamformer comprises a charge domain processor.

9. The system of paragraph 1 further comprising a processor programmed to actuate the system to collect at least 10 images per second.

10. A medical ultrasound scan head comprising:

## EP 3 376 253 A2

a two dimensional array of transducer elements in a probe housing; and  
a first beamformer device in the probe housing, the first beamformer device having a plurality of sub-arrays.

5 11. The scan head of paragraph 10 wherein the first beamformer device comprises a plurality of multiplexer elements.

12. The scan head of paragraph 10 wherein the probe housing is connected to a processor housing with a first cable.

13. The scan head of paragraph 10 wherein the two dimensional array comprises a sparse array.

10 14. The scan head of paragraph 10 wherein the first beamformer device comprises a charge domain processor.

15. A medical ultrasound imaging system comprising:

15 a two dimensional array of transducer elements in a probe housing;  
a switching device in the probe housing that switches the array from a first sparse array pattern to a second  
sparse array pattern; and  
a processor programmed to sparsely actuate the transducer array.

20 16. The system of paragraph 15 wherein the probe housing contains a plurality of multiplexer elements that switches  
the array between a plurality of sparse array patterns.

25 17. The system of paragraph 15 further comprising a processor housing connected to the probe housing, the process  
housing having an image processor programmed to perform 3D imaging processing and Doppler processing and  
having a controller to sequentially actuate sparsely selected array elements.

18. The system of paragraph 15 wherein the two dimensional array comprises a sparse array having at least 256  
transducer elements.

30 19. The system of paragraph 15 wherein the first pattern corresponds to a first scan angle and the second pattern  
corresponds to a second scan angle different from the first scan angle.

20. A medical ultrasound imaging system comprising:

35 a two dimensional array of transducer elements in a probe housing;  
a multiplexing network to sparsely actuate the array elements;  
a beamformer device in a second housing, the beamformer being in communication with the probe housing to  
transmit and receive data from selectively activated transducer elements; and  
a controller in the second housing in communication with the probe housing to sequentially activate selected  
transducer elements.

40 21. The system of paragraph 20 wherein the multiplexing network is in the probe housing.

22. The system of paragraph 20 wherein the second housing is connected to a processor housing.

45 23. The system of paragraph 20 wherein the second housing comprises a processor.

24. The system of paragraph 20 further comprising a standard communication interface between the second housing  
and a processor housing.

50 25. The system of paragraph 24 wherein the communication interface comprises a IEEE 1394 interface.

26. The system of paragraph 24 wherein the communication interface comprises a universal serial bus (USB).

55 27. The system of paragraph 20 further comprising a processor programmed to perform scan conversion and Doppler  
processing with a software module.

28. A medical ultrasound imaging system comprising:

## EP 3 376 253 A2

a two dimensional array of transducer elements in a probe housing; and  
a controller to sparsely activate transmitting transducer elements of the two dimensional array.

5 29. The system of paragraph 28 further comprising a beamformer device having a plurality of beamformer elements and a plurality of multiplexer elements.

30. The system of paragraph 28 further comprising a processor housing having an image processor programmed to perform 3D imaging processing and Doppler processing.

10 31. The system of paragraph 30 further comprising a second housing, that is connected to the probe housing with a first cable and is connected to the processor housing with a second cable.

32. The system of paragraph 28 wherein the two dimensional array has at least 256 elements.

15 33. The system of paragraph 28 further comprising a plurality of multiplexer elements in the probe housing.

34. The system of paragraph 28 further comprising a beamformer device that comprises a digital beamformer.

20 35. The system of paragraph 28 further comprising a beamformer that comprises a charge domain processor.

36. The system of paragraph 28 further comprising a processor programmed to actuate the system to collect at least 10 images per second.

25 37. The system of paragraph 30 further comprising a plurality of multiplexer elements in the second housing.

38. The system of paragraph 28 wherein the array of transducer elements comprises a sparse array of transmit elements and an array of receiver elements.

30 39. The system of paragraph 28 wherein at least 75 percent of the transducer elements comprise receiver elements and less than 25 percent of the transducer elements are transmit elements.

40. The system of paragraph 1 wherein controller is connected to a processor that is programmed to control transducer array operation.

35 41. The system of paragraph 38 wherein the transmit array is operated independently of the receiver array.

42. The system of paragraph 28 wherein the sparse array can be programmably selected among the array elements.

## 40 **Claims**

1. A medical ultrasound imaging system comprising:

45 an array of transducer elements in a probe housing, the array of transducer elements having a plurality of transducer sub-arrays;

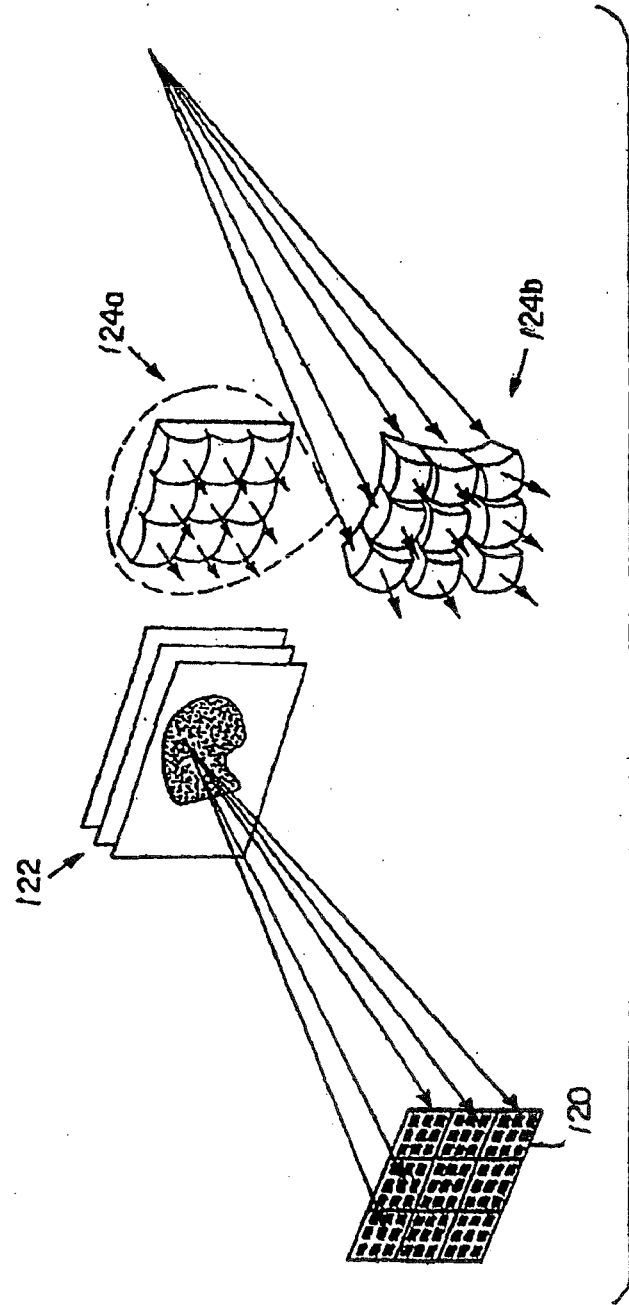
a first beamformer device in the probe housing, the first beamformer device having a plurality of sub-array beamformer elements that receive signals from the plurality of transducer sub-arrays;

a controller to actuate the plurality of transducer sub-arrays to generate a plurality of beams that are steered at a plurality of different scan angles for each transmit pulse; and

50 a second beamformer device in a second housing, the second beamformer being in communication with the probe housing to receive beamformed data from the first beamformer device, the second housing including a data processor and a display.

55 2. The system of claim 1 further comprising a multiplexer device in the probe housing, the multiplexer device having a plurality of multiplexer elements, each of the plurality of multiplexer elements being connected to one of the sub-array beamformer elements, or optionally, a summing device for summing of a plurality of delayed signals within the probe housing.

3. The system of claim 1 wherein the first beamformer device comprises one or more of: a) a plurality of beamformer elements and a corresponding plurality of multiplexer elements; and b) a plurality of beamforming channels that receives signals from a two dimensional sub-array having  $N \times M$  transducer elements.
- 5 4. The system of claim 1 wherein the second housing comprises an image processor programmed to perform 3D image processing and Doppler processing.
- 10 5. The system of claim 4 wherein the second housing is connected to the probe housing with a first cable, or optionally, further comprising a flexible cable connecting a circuit board within the probe housing to a transducer subarray.
- 15 6. The system of claim 1 wherein the array has at least 128 transducer elements, or optionally, wherein the system further comprises a subarray processor.
7. The system of claim 1 wherein the second beamformer device comprises a digital beamformer.
8. The system of claim 1 wherein the first beamformer device comprises a charge domain processor.
9. The system of claim 1 further comprising the data processor is programmed to actuate the system to collect at least 10 3D images per second.
- 20 10. The system of claim 1 wherein the system comprises a portable ultrasound system having a beamsteering circuit that steers the plurality of beams.
- 25 11. The system of claim 1 further comprising a plurality of transmit circuits in the second housing that are connected to the multiplexer device and a system controller connected to the transmit circuits such that the system controller actuates a plurality of sparse transmission array patterns of the array of transducer elements.
- 30 12. The system of claim 1 further comprising a transmit circuit that generates a transmit pulse actuating 16 separately steerable beams with the array of transducer elements.
- 35 13. The system of claim 12, wherein said 16 separately steerable beams can each have a different scan angle for each transmit pulse.
- 40 14. A medical ultrasound scan head comprising:  
an array of transducer elements in a probe housing, the probe housing having a cable for connecting to a medical ultrasound processor;  
a transmission circuit in the probe housing that controls transmission of a plurality of beams for each transmission pulse signal;  
a first beamformer device in the probe housing, the first beamformer device including a plurality of sub-array beamformer elements that receive signals from a corresponding plurality of transducer sub-arrays in the array of transducer elements; and  
a multiplexing network in the probe housing, the multiplexing network having a plurality of multiplexer elements that are connected to the plurality of sub-array beamformer elements, each sub-array beamformer element connected to one of the plurality of transducer sub-arrays.
- 45 15. The scan head of claim 14 wherein the transducer elements include a 2 dimensional array, which optionally comprises a sparse transmission array, or optionally, wherein the first beamformer device comprises a charge domain processor, or alternatively, wherein the probe housing comprises one or more circuit boards, a circuit board being connected to transducer elements with a flexible cable, and further comprising a cable attached to the probe housing to transmit partially beamformed data to an external portable ultrasound display and processor housing.
- 50
- 55



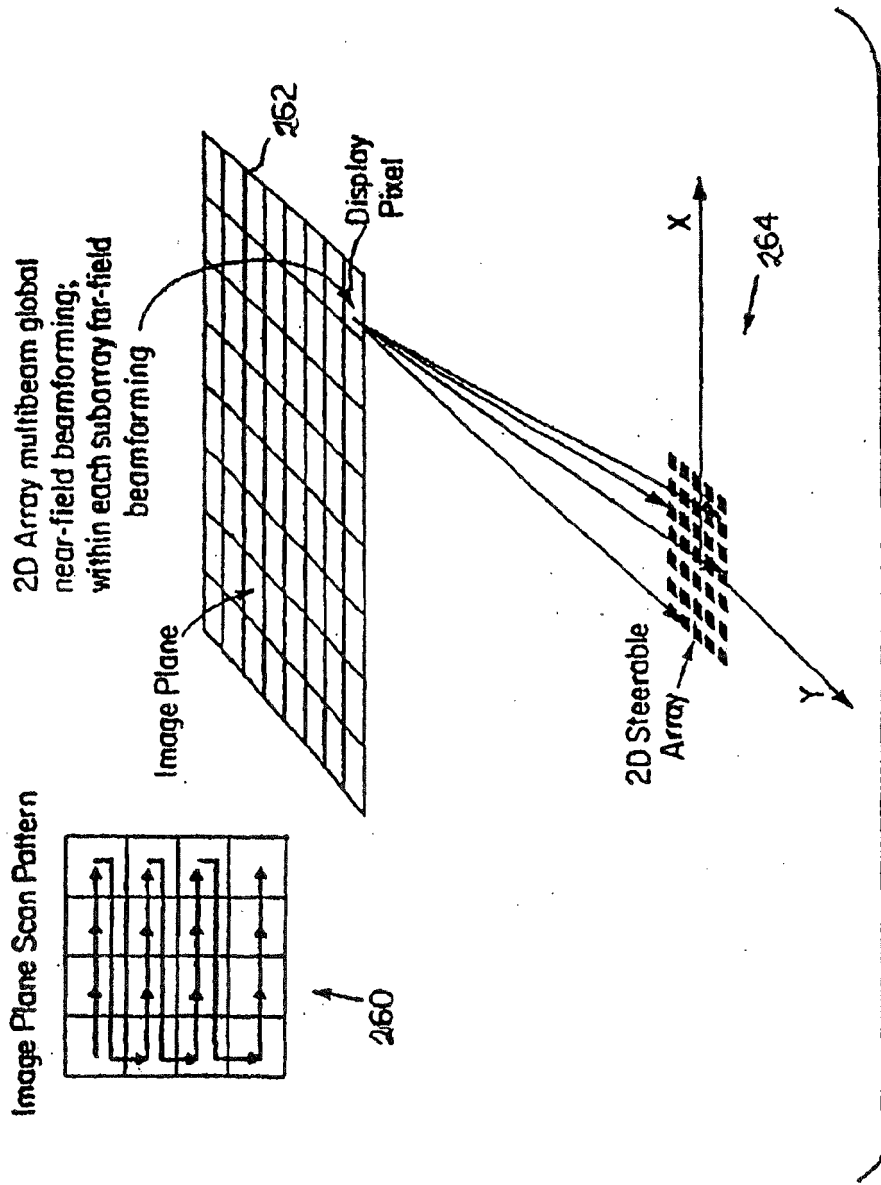


FIG. 2

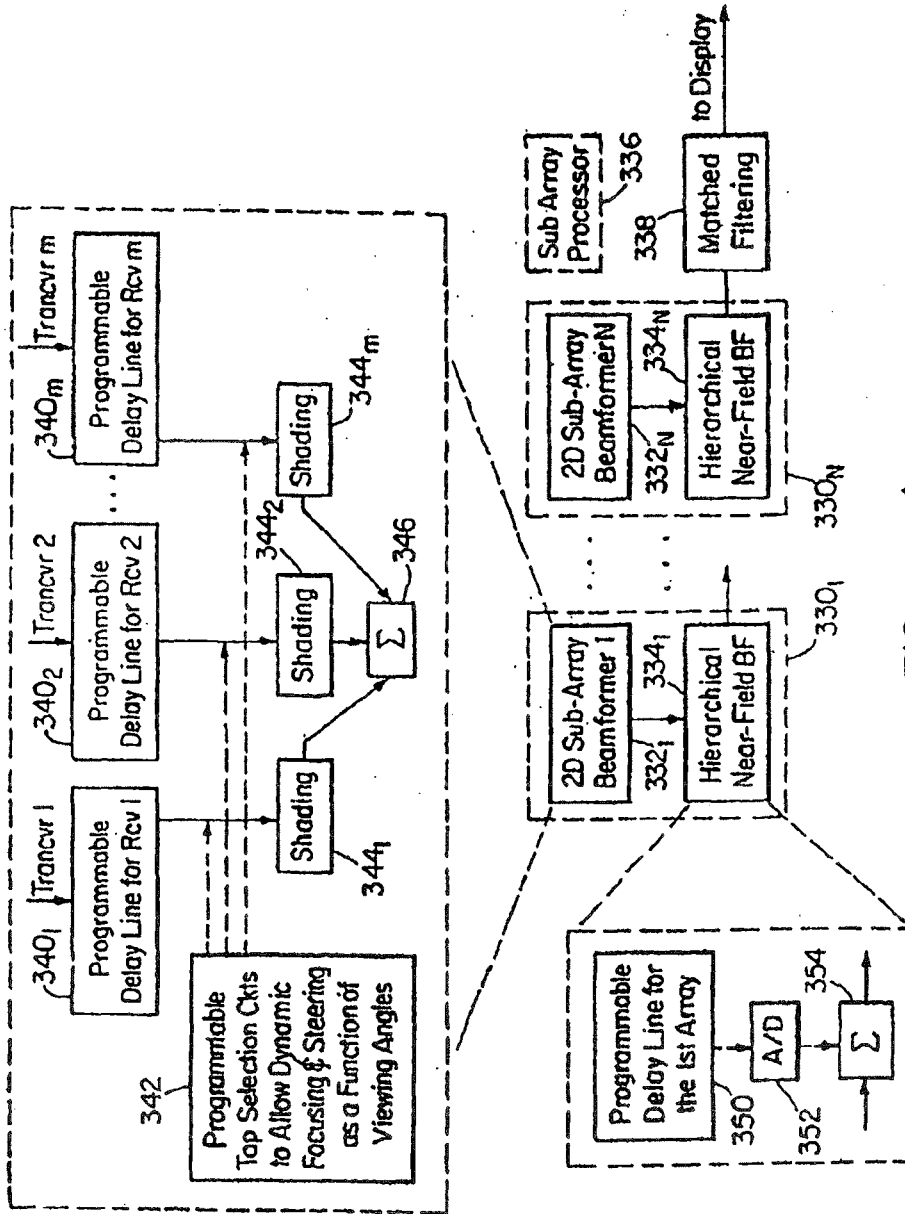
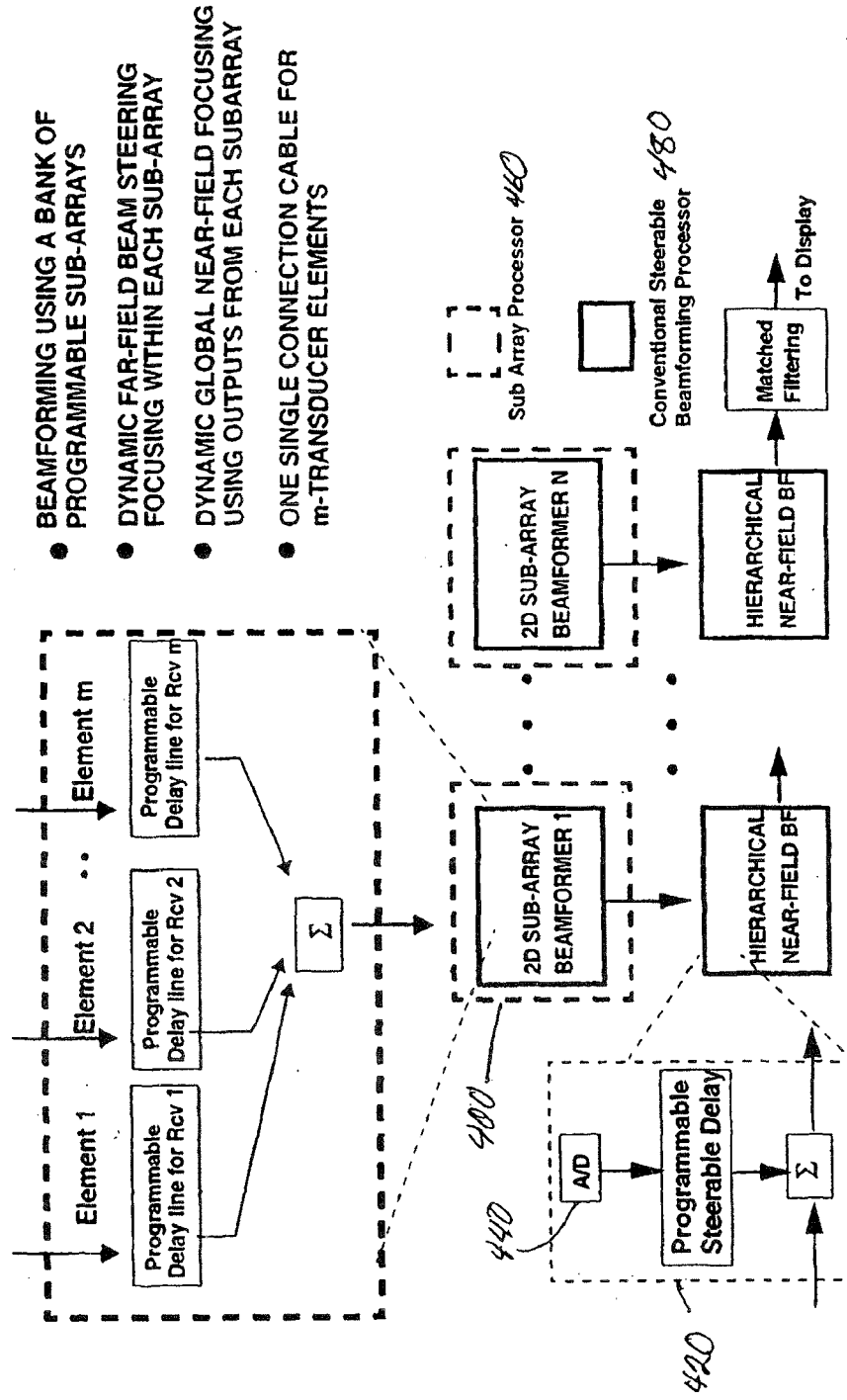


FIG. 3A

# ELECTRONICALLY-CONTROLLED ACOUSTIC CONFORMAL LENS



- BEAMFORMING USING A BANK OF PROGRAMMABLE SUB-ARRAYS
- DYNAMIC FAR-FIELD BEAM STEERING FOCUSING WITHIN EACH SUB-ARRAY
- DYNAMIC GLOBAL NEAR-FIELD FOCUSING USING OUTPUTS FROM EACH SUBARRAY
- ONE SINGLE CONNECTION CABLE FOR m-TRANSDUCER ELEMENTS

Fig. 3B

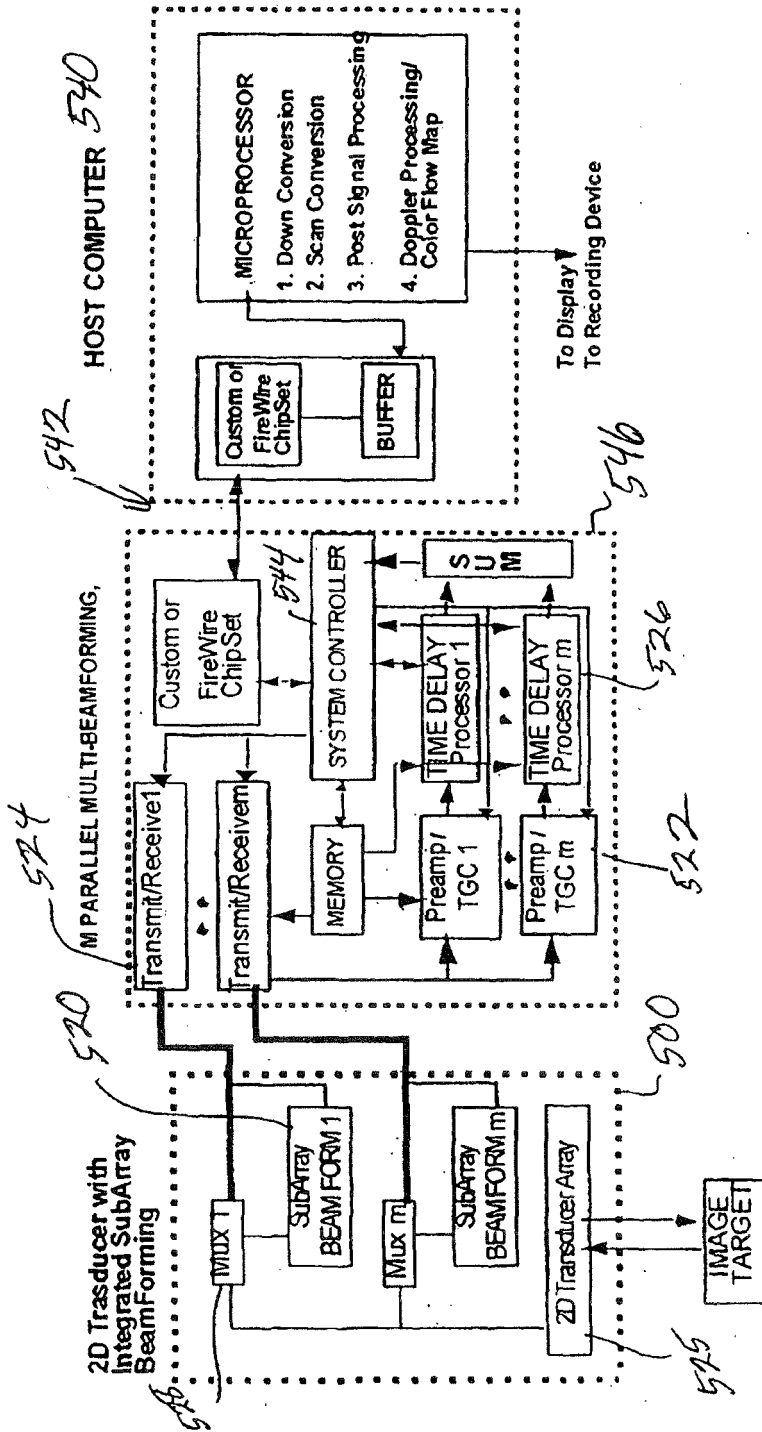


Figure 4

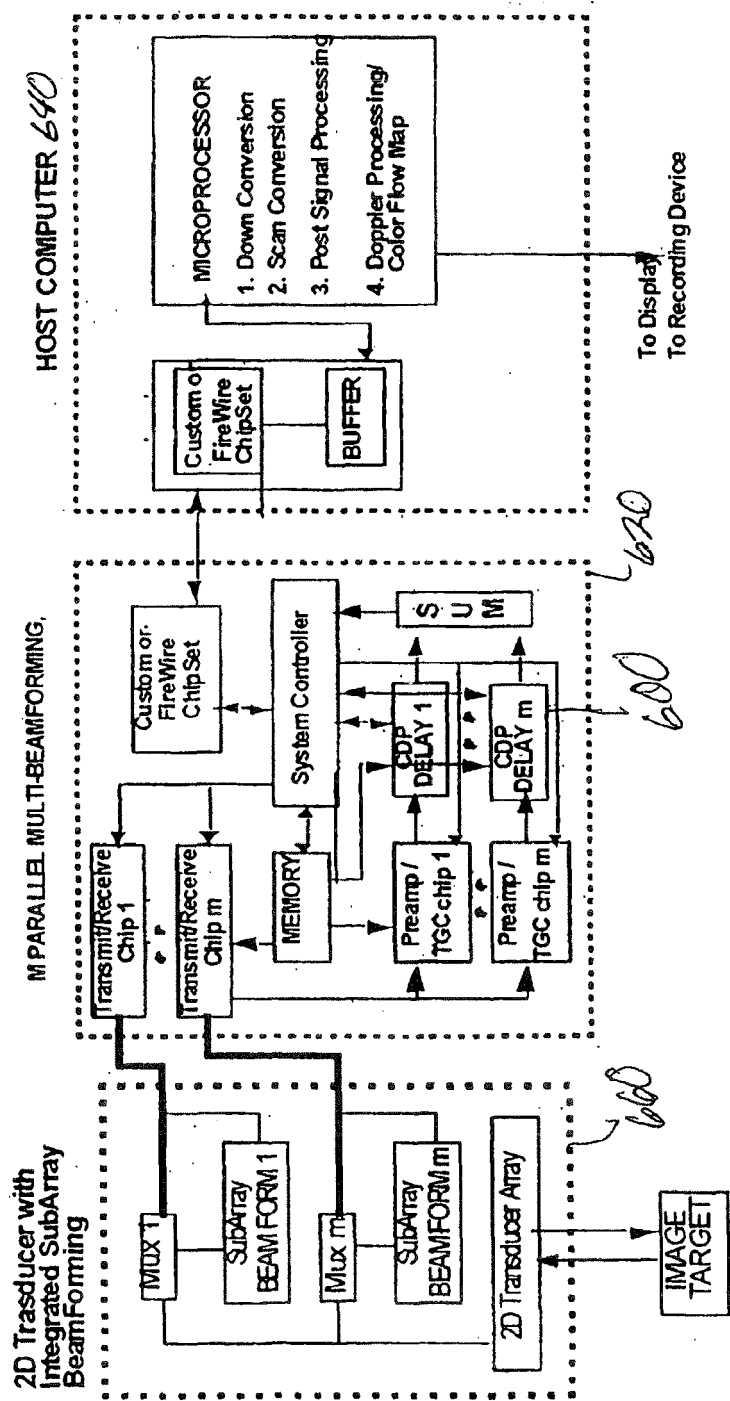


Figure 5

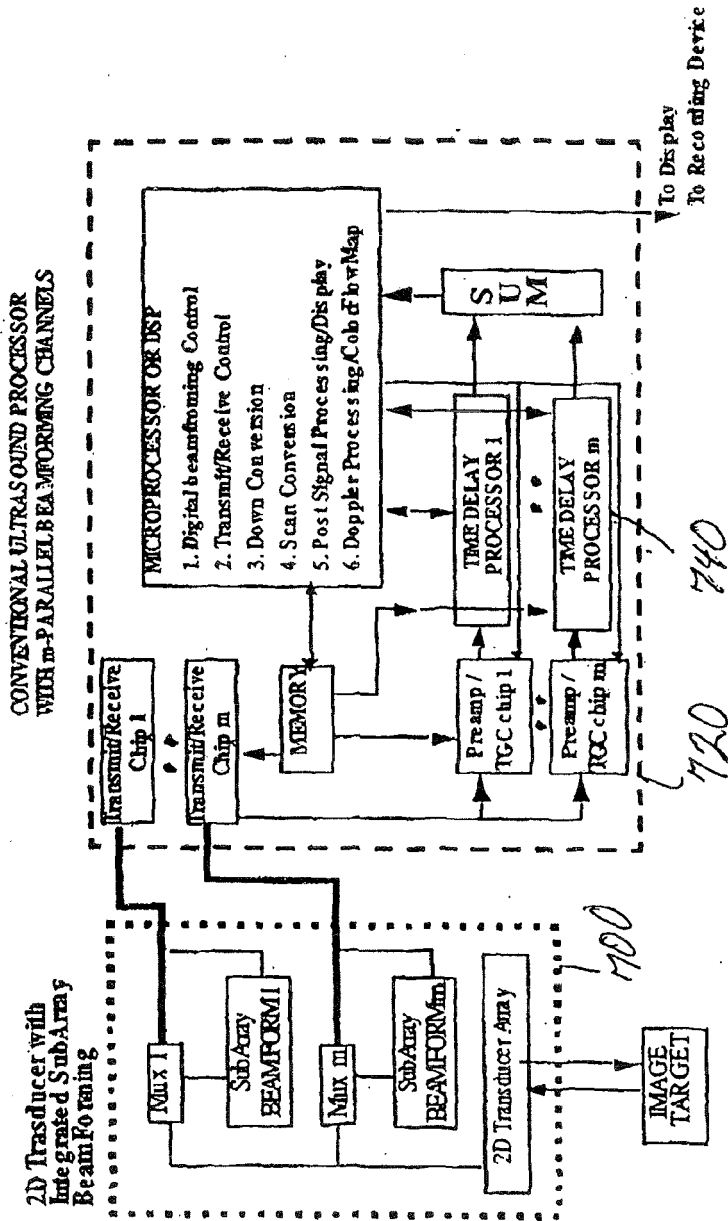
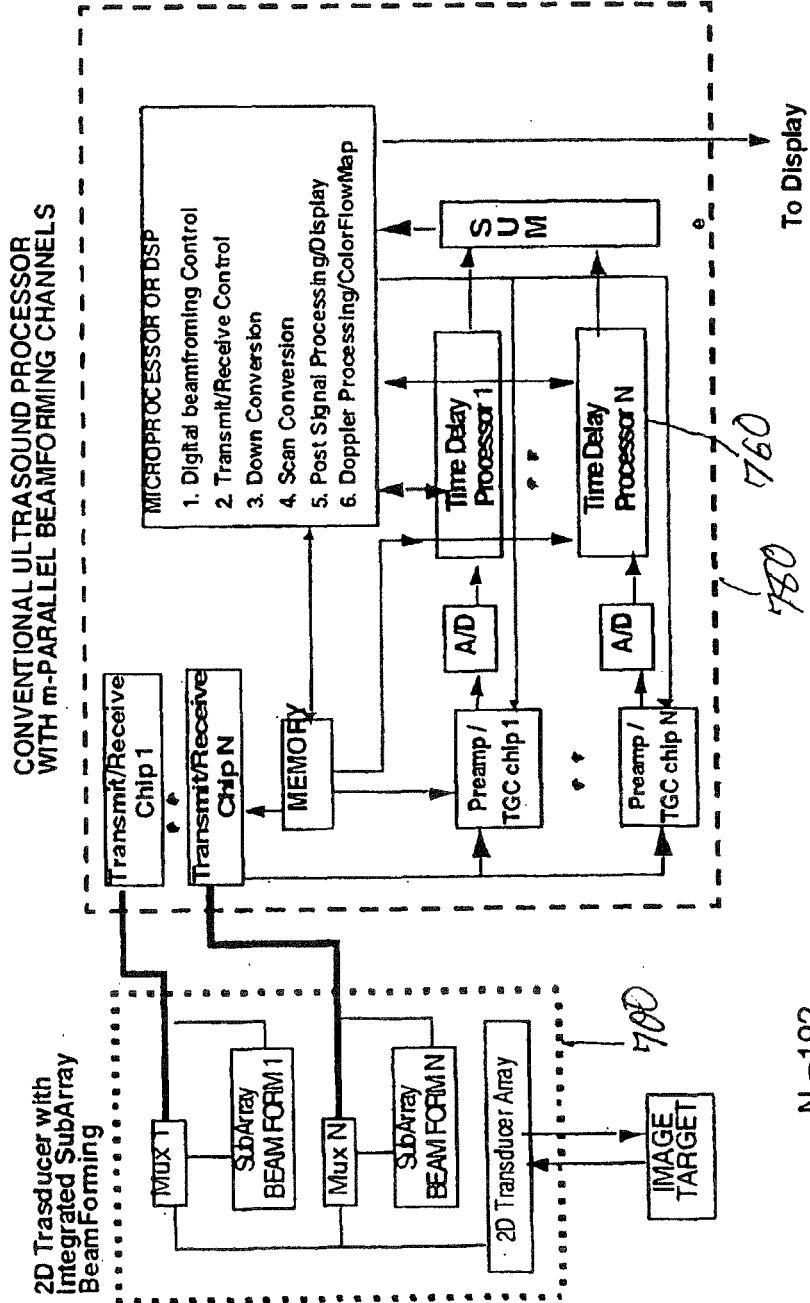


Fig. 6A

# Real-Time 3D/4D Imaging



N = 192

Fig. 6B

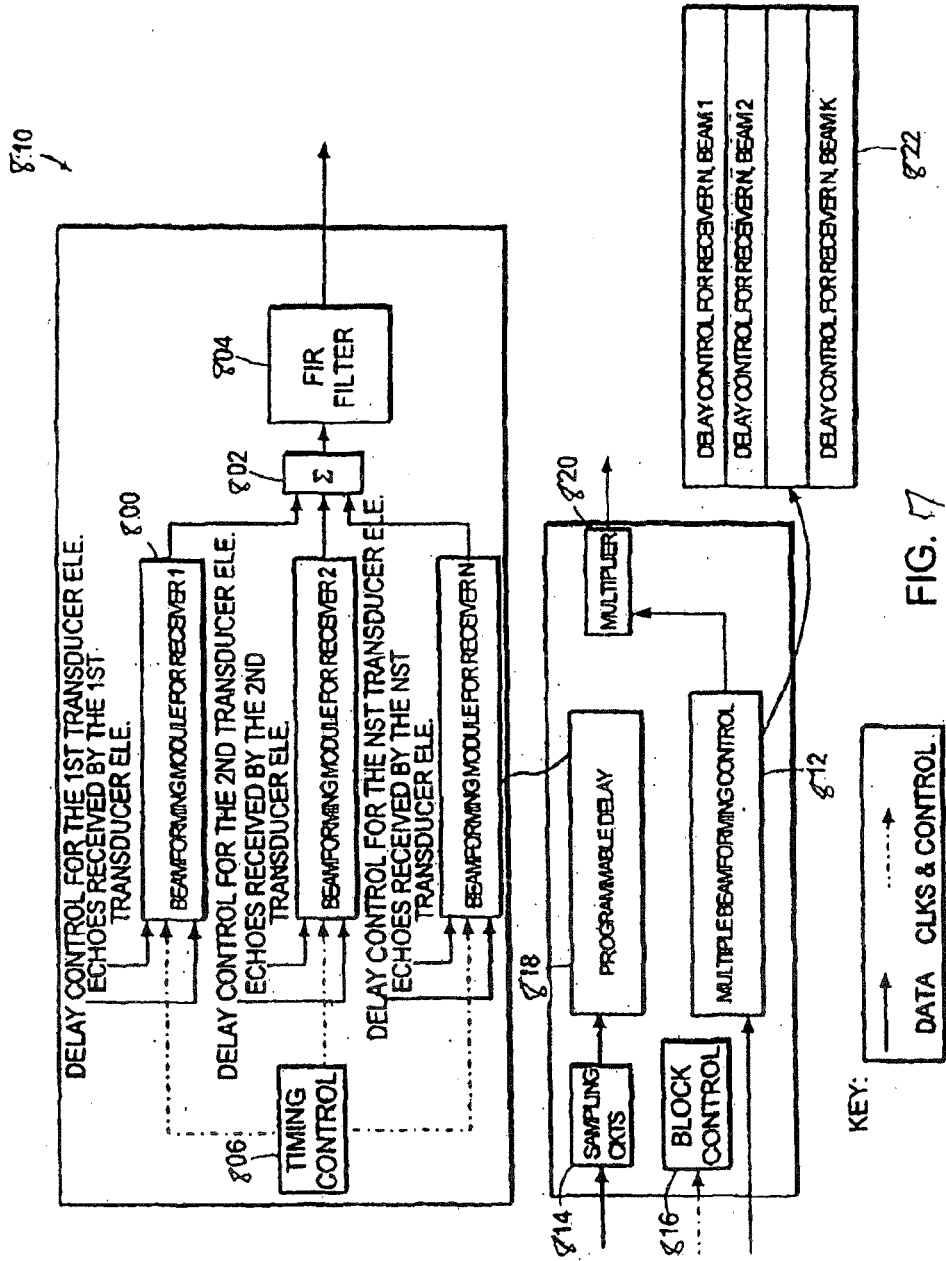


FIG. 17

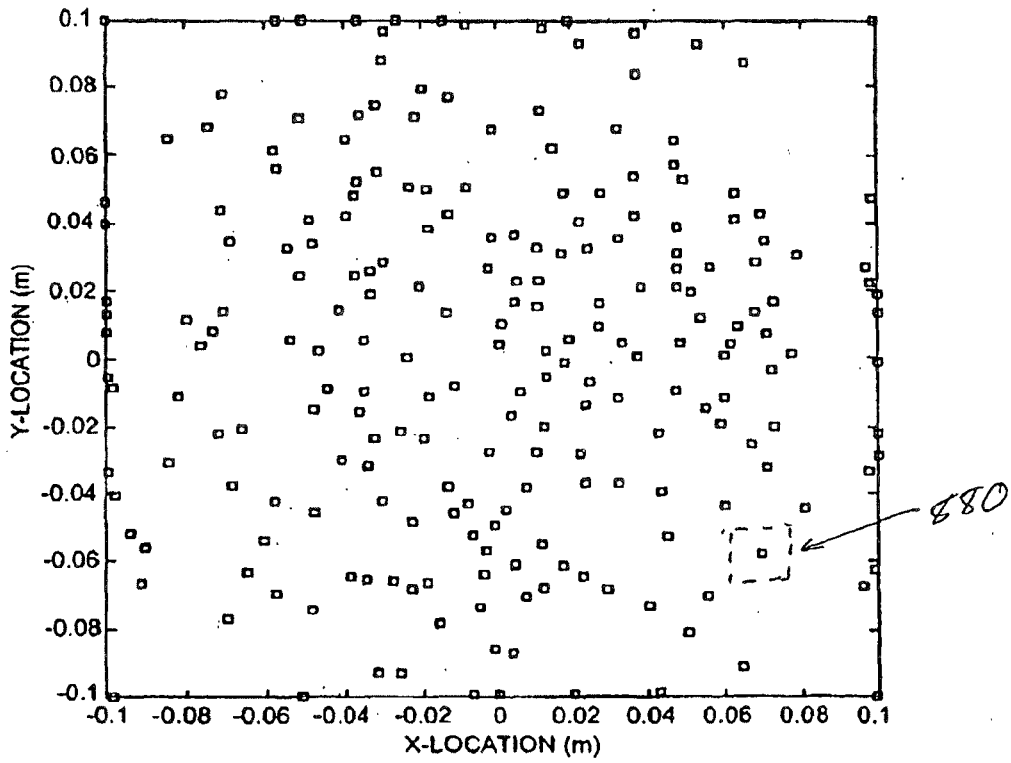


FIG. 8A

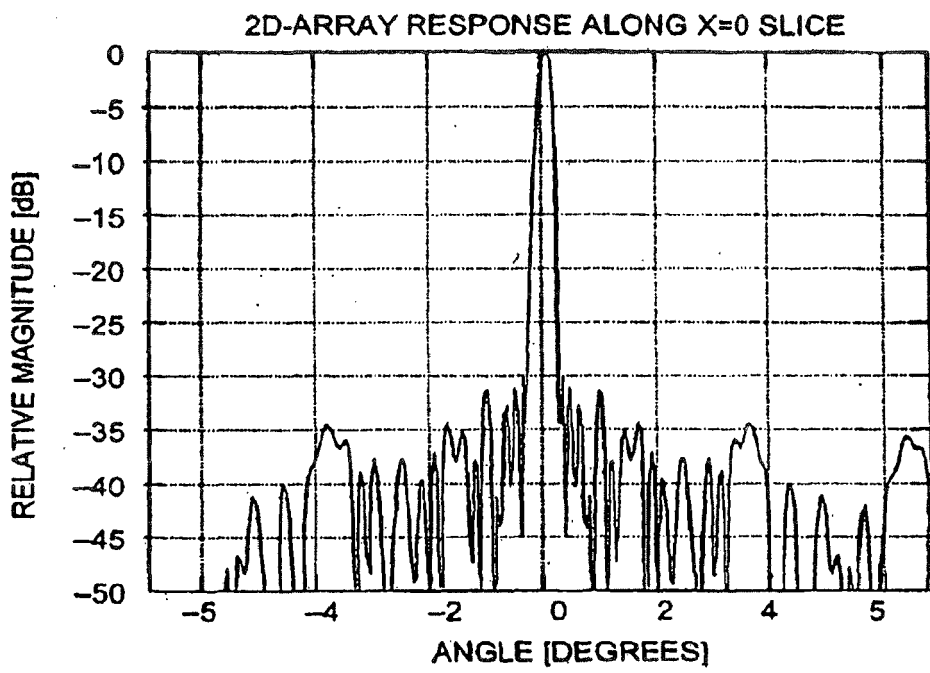


FIG. 8B

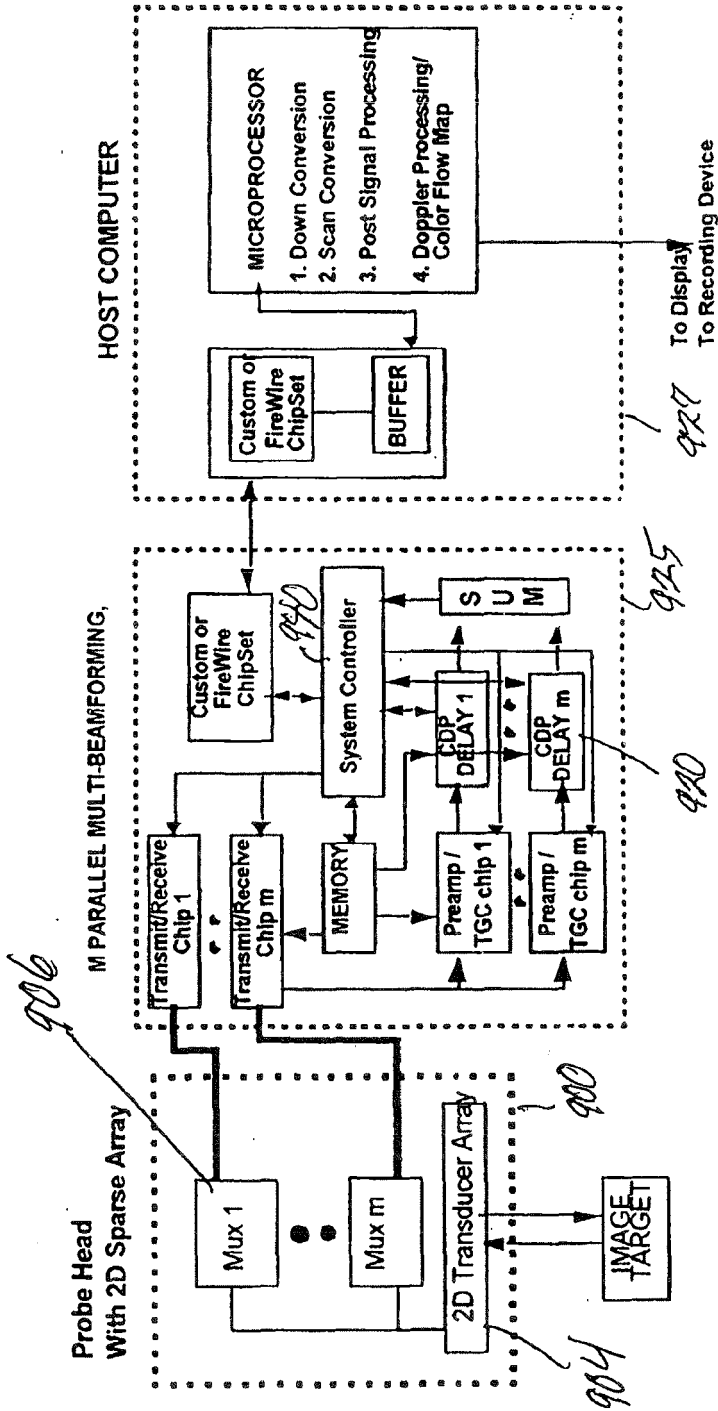


Fig. 9A

CONVENTIONAL ULTRASOUND PROCESSOR  
WITH M-PARALLEL BEAMFORMING CHANNELS

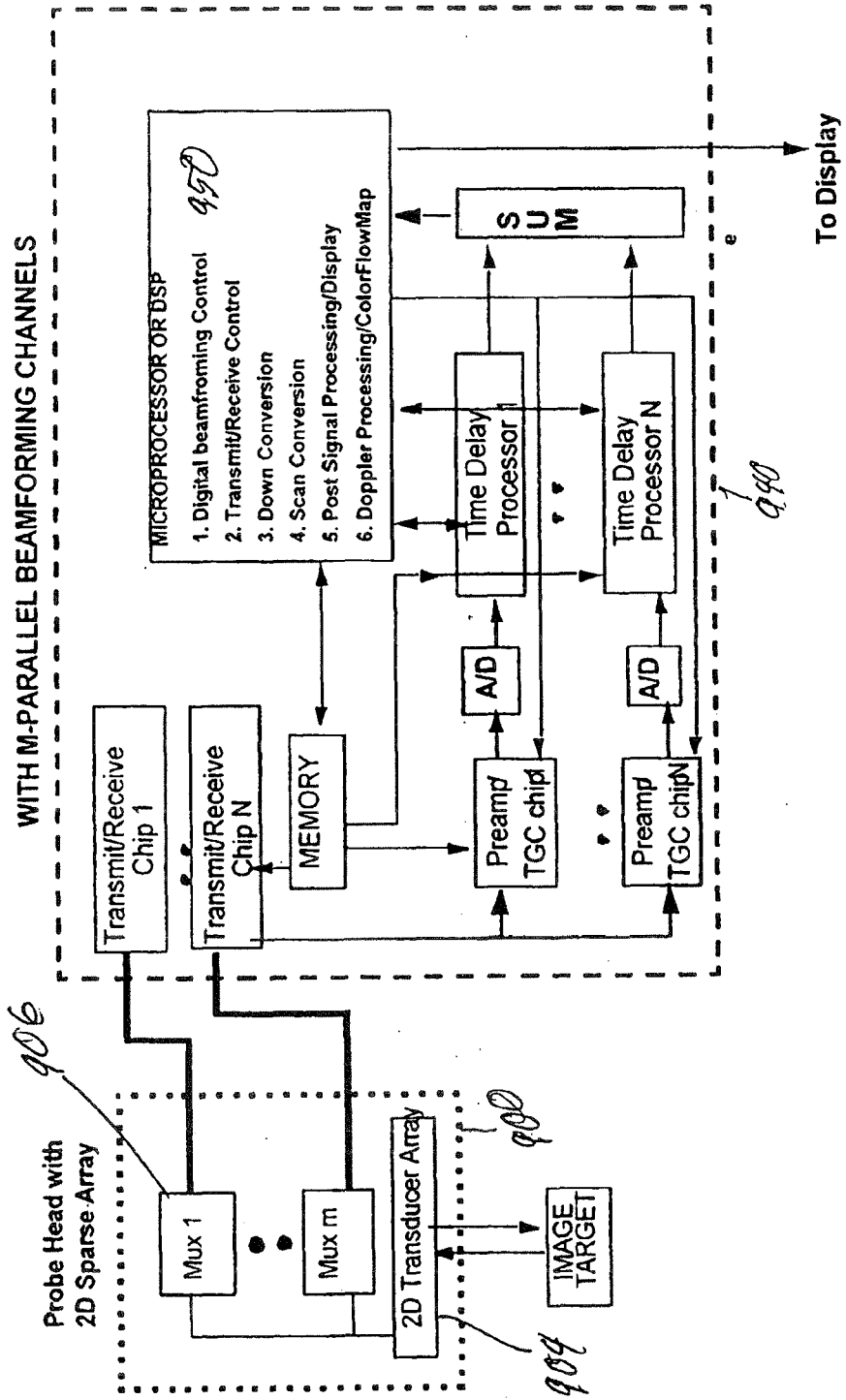


Fig 9B

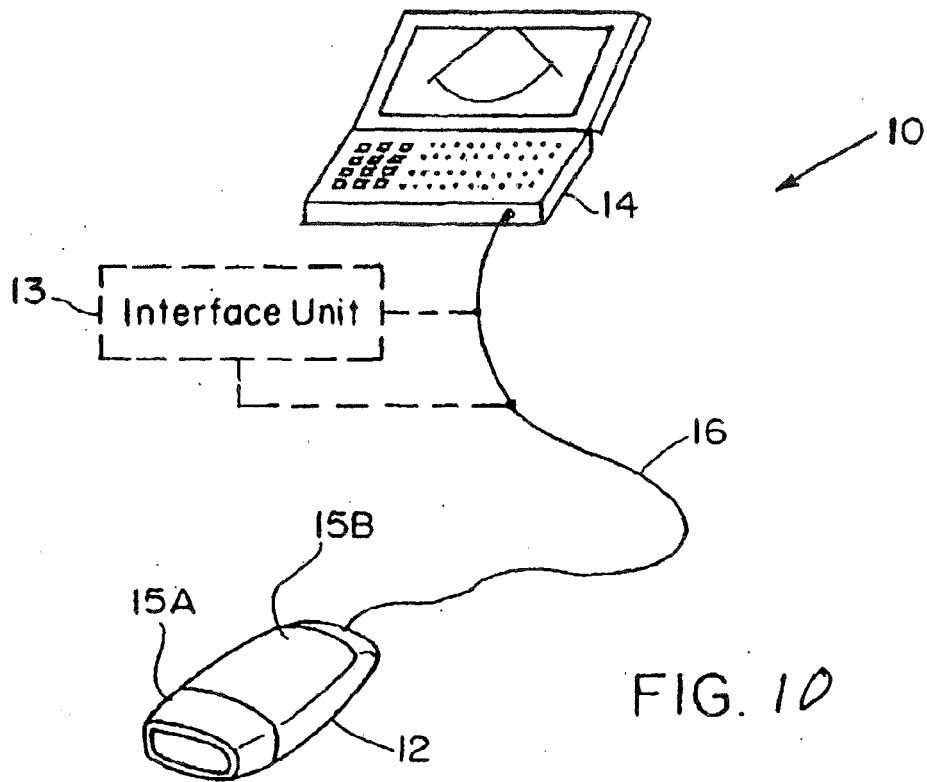


FIG. 10

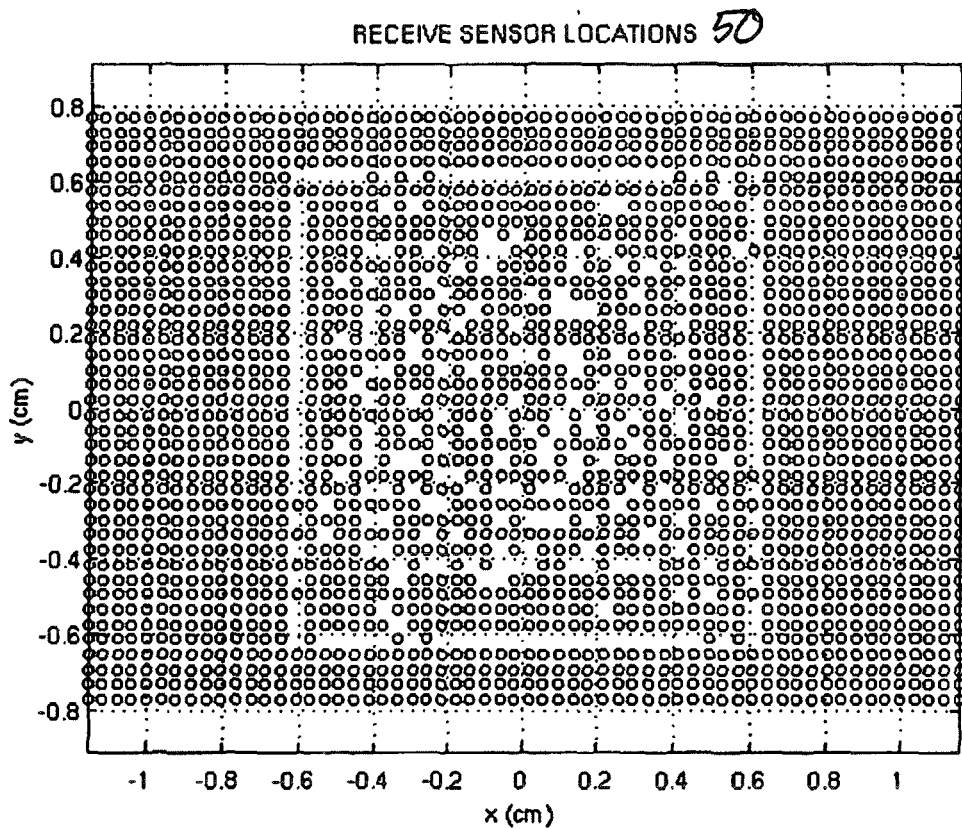
SPARSE ARRAY TRANSMIT, NEAR FULLY-  
POPULATED RECEIVE ARRAYS

Figure 11: Final element locations for the near fully-populated receive array. The 2400-element array is depopulated by the 256 sparse array transmit elements to yield 2144 receive element locations. These elements are independent and do not overlap the sparse-array transmit elements.

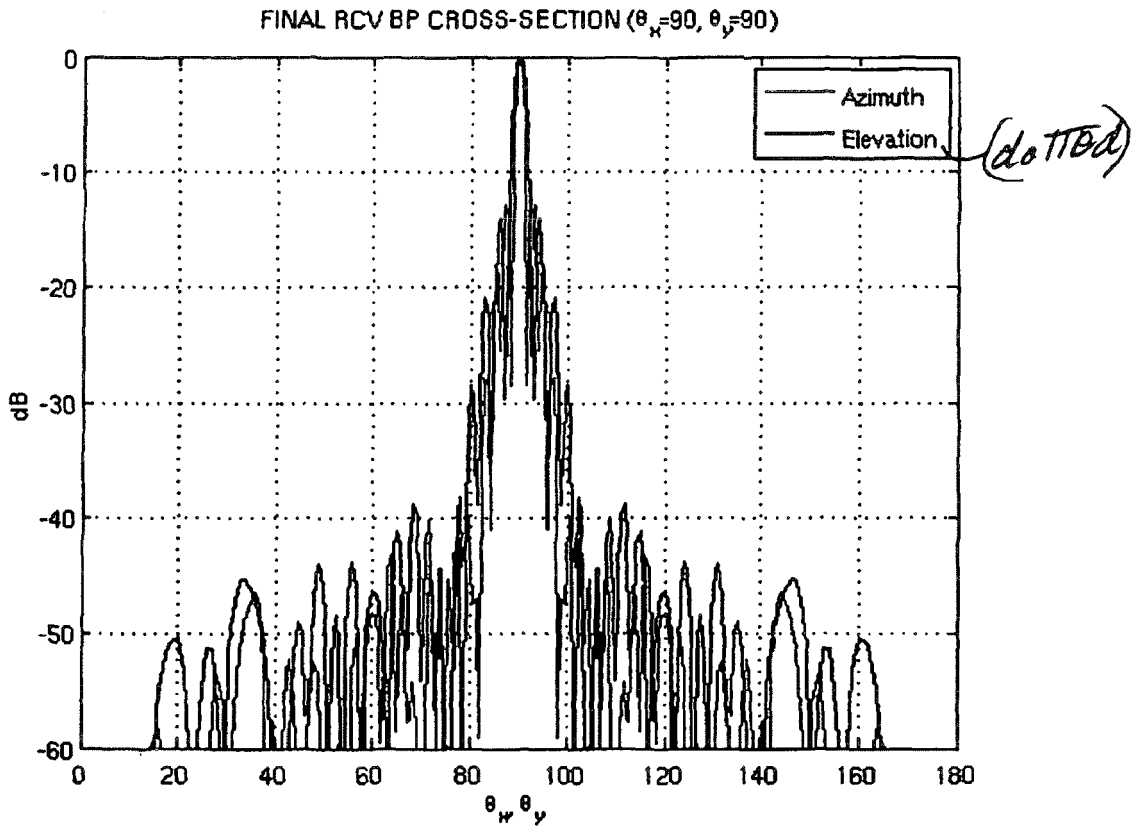


Figure 2: Azimuth and elevation cross-sections of the receive array beam pattern. The first sidelobe is approximately -13 dB relative to the central peak. The grating lobes are less than -30 dB relative to the peak. Given that the 2D array is wider than tall, the azimuthal beamwidth (plotted in blue) is slightly narrower than the elevation beamwidth (plotted in green).

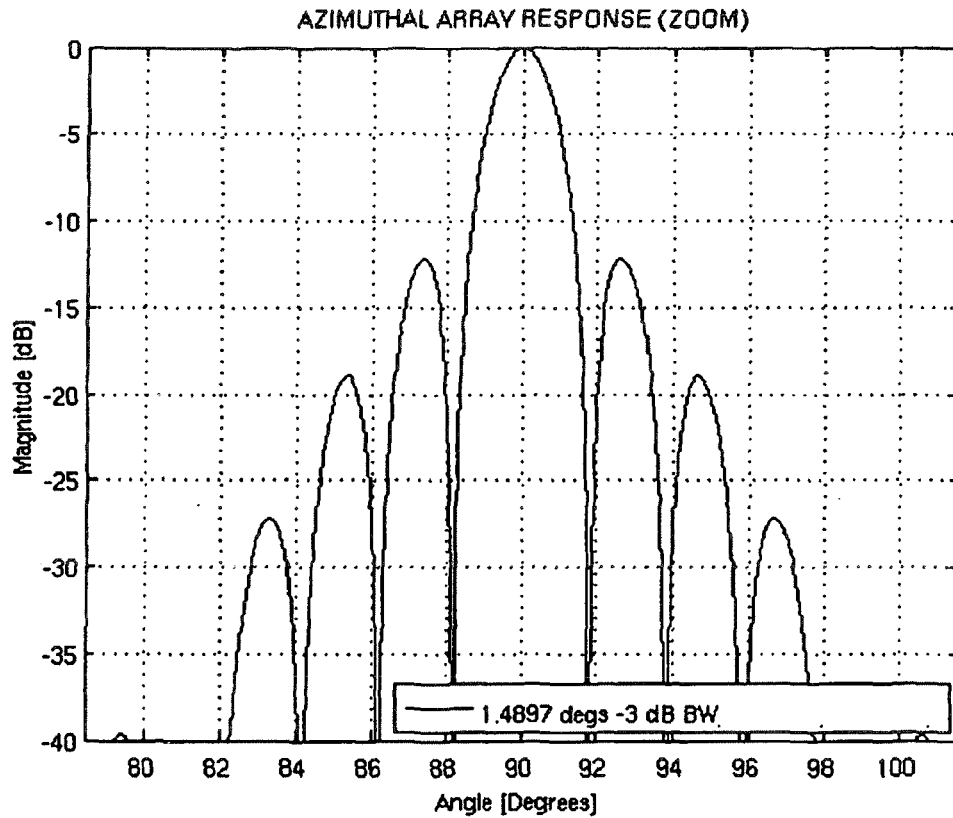


Figure3: Magnifying the azimuthal beam pattern reveals the mainlobe and sidelobe structure. For this case, the beamwidth is approximately 1.5 degrees. The beam pattern is nearly identical to the fully-populated 60x40 element beam pattern.

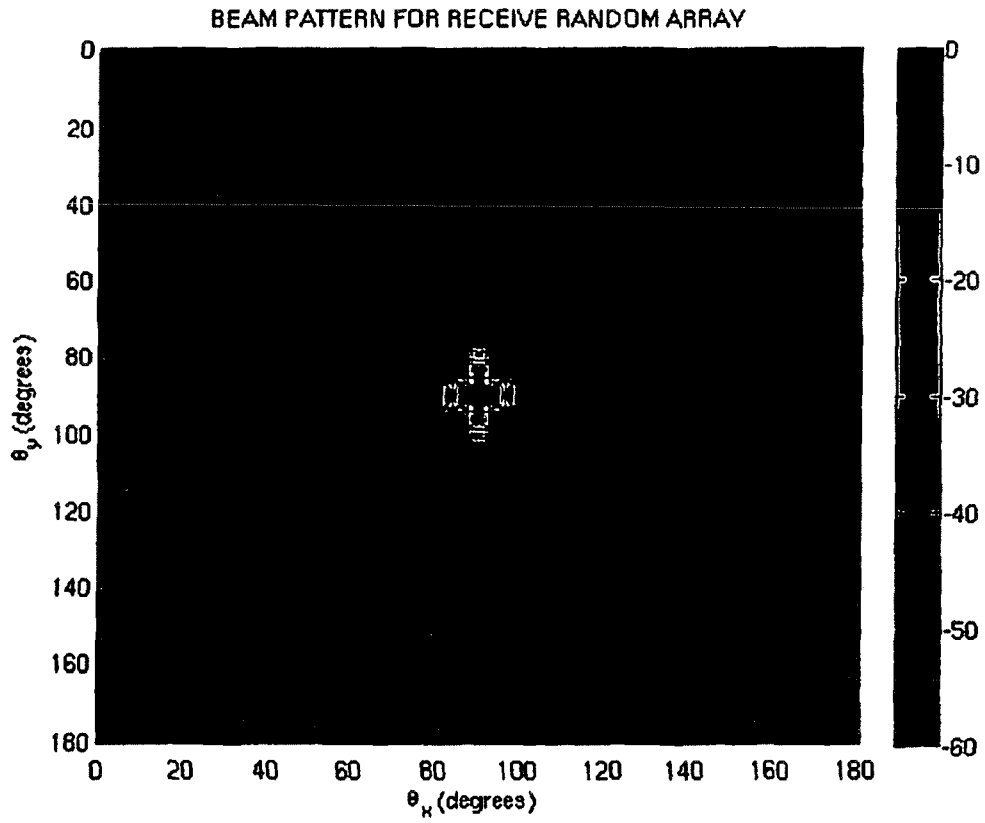


Figure 4: Near fully-populated receive array beam pattern. The receive sparse array is comprised of a 2144 elements. There are no anomalous sidelobes due to depopulating the center of the array by 256 (transmit) elements.

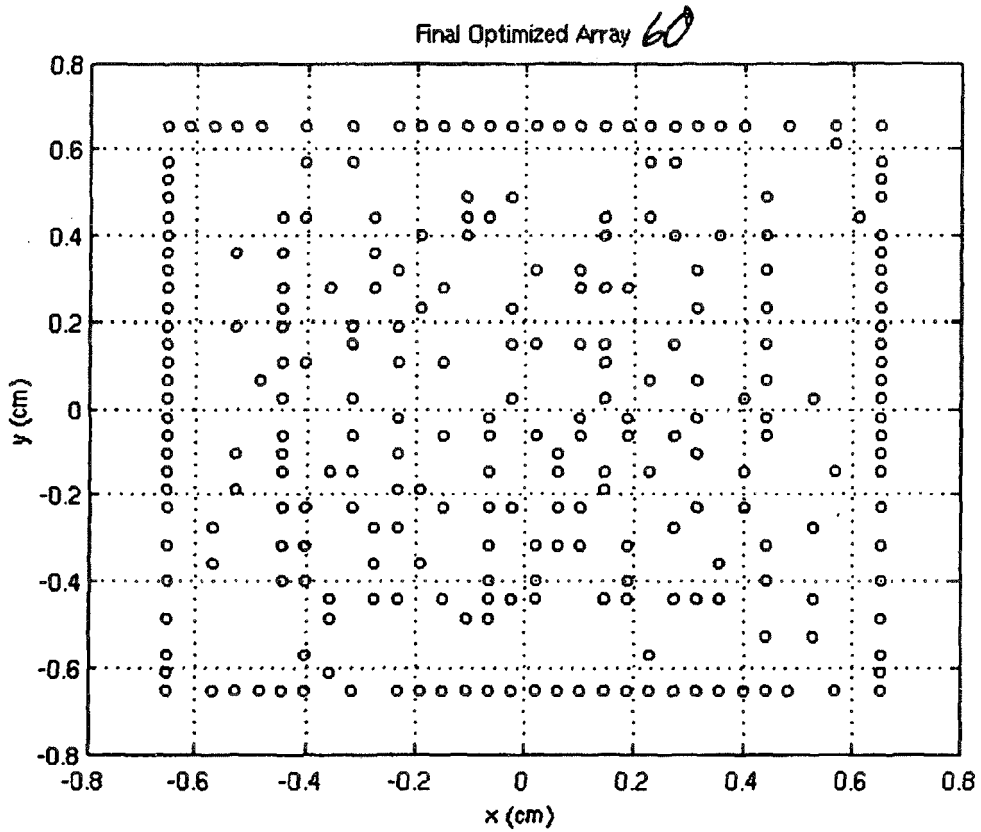


Figure 5: Final element locations for the transmit sparse array. The 256 element locations are confined to the central  $32 \times 32$  elements of the fully populated array. These elements are independent and do not overlap the receive array elements.

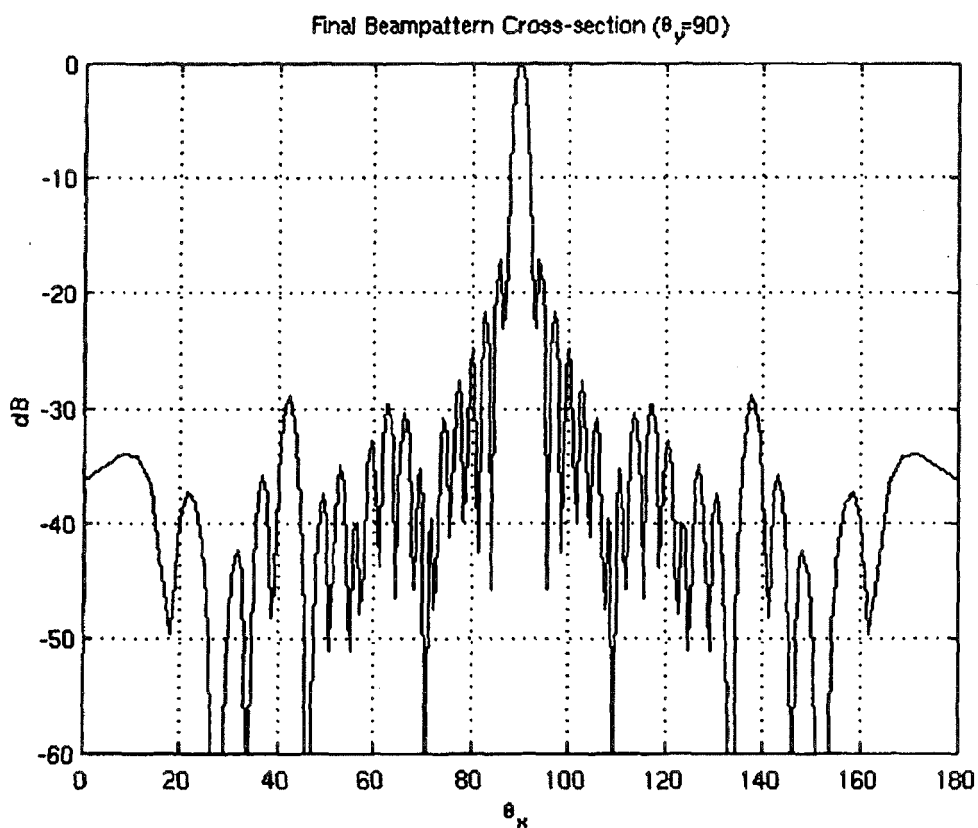


Figure 6: Cross section view of the transmit sparse array beampattern. The first sidelobe is approximately -17 dB relative to the central peak. The grating lobes are less than -27 dB relative to the peak. The sparse-array optimization algorithm minimizes the sidelobe energy +/- 45 degrees in elevation and +/- 45 degrees in elevation.

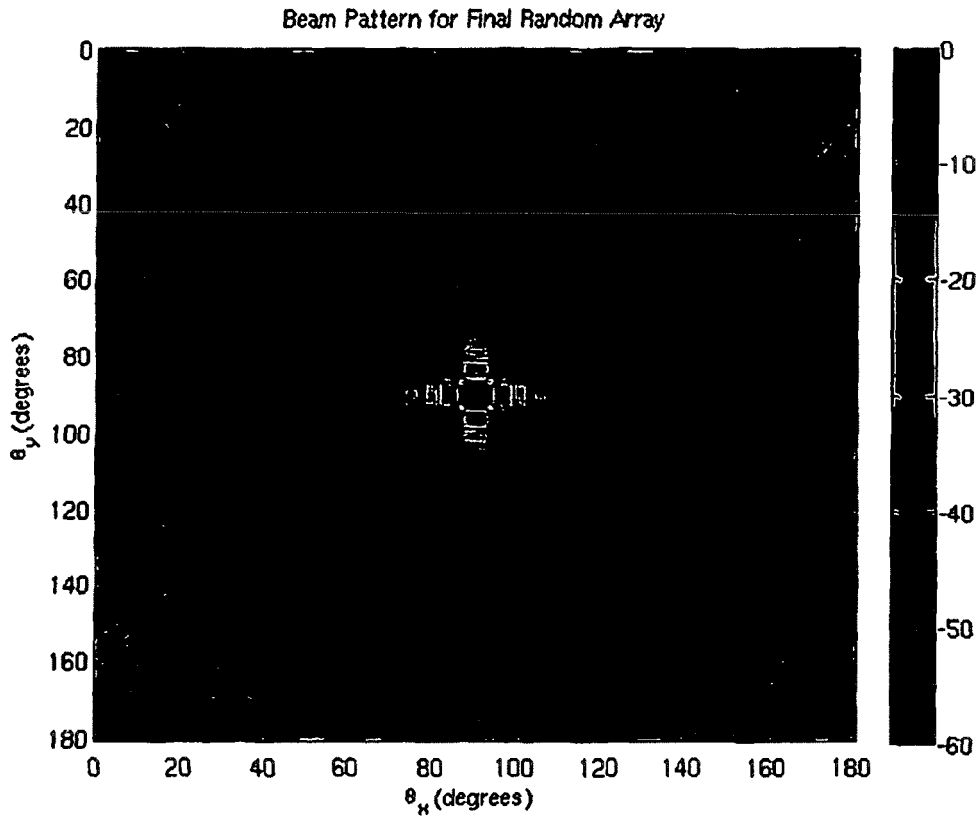


Figure 7: Sparse transmit array beam pattern. The transmit beam pattern is designed to uniformly cover a 4x4 beam data pyramid. The transmit sparse array is comprised of a 256-element subset of the fully populated 2400-element array (approximately 10% fill).

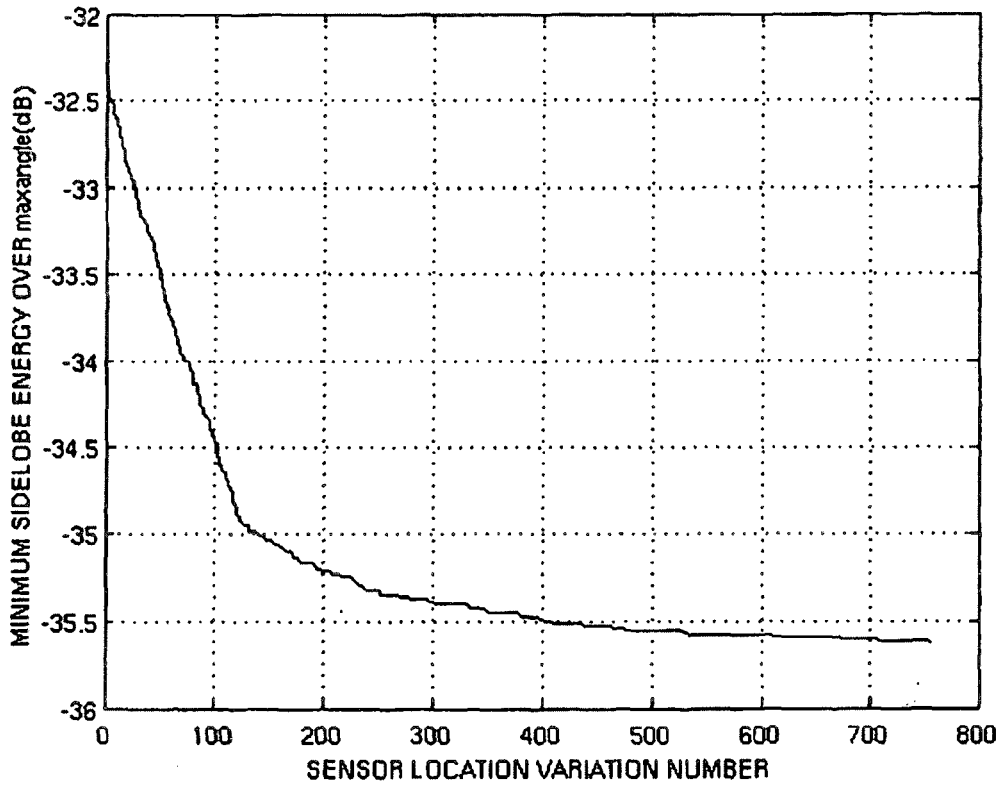


Figure 8: The transmit/receive array design algorithm required over 750 iterations to minimize the transmit and receive sidelobe energy within the  $\pm 45$  degree azimuth,  $\pm 45$  degree elevation region. The final sparse transmit-array element locations limit the average sidelobe energy to less than -35 dB relative to the central peak of the beam pattern.

**REFERENCES CITED IN THE DESCRIPTION**

*This list of references cited by the applicant is for the reader's convenience only. It does not form part of the European patent document. Even though great care has been taken in compiling the references, errors or omissions cannot be excluded and the EPO disclaims all liability in this regard.*

**Patent documents cited in the description**

- US 47409806 A [0001]
- US 6292433 B [0011]
- US 6721235 B [0020]
- US 6106472 A [0033]
- US 6869401 B [0033]

专利名称(译)	超声3D成像系统		
公开(公告)号	<a href="#">EP3376253A2</a>	公开(公告)日	2018-09-19
申请号	EP2017196129	申请日	2007-06-22
[标]申请(专利权)人(译)	泰拉科技公司		
申请(专利权)人(译)	TERATECH CORPORATION		
当前申请(专利权)人(译)	TERATECH CORPORATION		
[标]发明人	CHIANG ALICE M BRODSKY MICHAEL HE XINGBAI WONG WILLIAM M		
发明人	CHIANG, ALICE M BRODSKY, MICHAEL HE, XINGBAI WONG, WILLIAM M		
IPC分类号	G01S7/52 G01S15/89 A61B8/00 A61B8/02 A61B8/06 A61B8/08 A61B8/12 A61B8/14 G10K11/34		
CPC分类号	A61B8/4477 A61B8/145 A61B8/4483 A61B8/483 G01S7/5208 G01S7/52082 G01S7/52085 G01S7/52095 G01S15/8925 G01S15/8927 G01S15/8959 G01S15/8961 G01S15/8993 G10K11/346		
代理机构(译)	GRAHAM WATT & CO LLP		
优先权	11/474098 2006-06-23 US PCT/US2007/014526 2007-06-22 WO		
其他公开文献	EP3376253A3		
外部链接	<a href="#">Espacenet</a>		

摘要(译)

超声成像系统技术领域本发明涉及一种超声成像系统，其中扫描头或者包括执行远场子阵列波束成形的波束形成器电路，或者包括激励所选元件的稀疏阵列选择电路。当与第二级波束形成系统一起使用时，可以生成三维超声图像。

