

(19)



(11)

EP 2 954 846 A1

(12)

EUROPEAN PATENT APPLICATION

(43) Date of publication:
16.12.2015 Bulletin 2015/51

(51) Int Cl.:
A61B 8/12 (2006.01) **A61B 8/00 (2006.01)**
A61B 8/08 (2006.01)

(21) Application number: **15171422.7**

(22) Date of filing: **10.06.2015**

(84) Designated Contracting States:
**AL AT BE BG CH CY CZ DE DK EE ES FI FR GB
GR HR HU IE IS IT LI LT LU LV MC MK MT NL NO
PL PT RO RS SE SI SK SM TR**
Designated Extension States:
BA ME
Designated Validation States:
MA

(71) Applicant: **Covidien LP**
Mansfield, MA 02048 (US)

(72) Inventor: **TAN, Wei**
201318 Shanghai (CN)

(74) Representative: **Soames, Candida Jane**
Maschio & Soames IP Limited
20 Carlton Crescent
Southampton, SO15 2ET (GB)

(30) Priority: **11.06.2014 US 201462010608 P**
04.05.2015 US 201514702976

(54) **SWIPE TO SEE THROUGH ULTRASOUND IMAGING FOR INTRAOPERATIVE APPLICATIONS**

(57) An ultrasound system has an ultrasound probe, a processing unit, and a display. The ultrasound probe includes a sensor configured to detect the position and orientation of the ultrasound probe and an ultrasound scanner configured to generate a plurality of ultrasound images. The processing unit is in communication with the sensor and the ultrasound scanner and configured to create a three-dimensional model from the position

and orientation of the ultrasound probe when each of the plurality of ultrasound images is generated. The display in communication with the processing unit and configured to output a view of a first layer of the three-dimensional model and configured to output a view of a second layer of the three-dimensional model in response to an intra-operative swipe across the display by a user.

EP 2 954 846 A1

Description

CROSS-REFERENCE TO RELATED APPLICATIONS

[0001] This application claims the benefit of and priority to U.S. Provisional Patent Application No. 62/010,608, filed June 11, 2014, the entire disclosure of which is incorporated by reference herein.

BACKGROUND

1. Technical Field

[0002] The present disclosure relates to ultrasound systems and, more specifically, to three-dimensional ultrasound systems configured to modify a display in response to an intraoperative swipe of a user.

2. Discussion of Related Art

[0003] Ultrasound imaging systems generate a cross-sectional view on an axial plane of an ultrasound transducer array. Depending on the location and orientation of the transducer, the ultrasound image presents differently on a display. It takes thorough knowledge of ultrasound anatomy to map these ultrasound images to real organs.

[0004] Surgeons are not trained on mapping ultrasound images to real organs, and thus, a surgeon is not generally capable of mapping ultrasound images to real organs. This prevents surgeons from utilizing ultrasound imaging systems as a tool to guide instruments during a surgical procedure, such as a minimally invasive surgical procedure.

[0005] During a minimally invasive surgical procedure, surgery is performed in any hollow viscus of the body through a small incision or through narrow endoscopic tubes (cannulas) inserted through a small entrance wound in the skin or through a naturally occurring orifice. Minimally invasive surgical procedures often require the clinician to act on organs, tissues and vessels far removed from the incision and out of the direct view of the surgeon.

[0006] Accordingly, there is a continuing need for instruments and methods to enable a surgeon to visualize a surgical site during a minimally invasive surgical procedure, i.e., intraoperatively.

SUMMARY

[0007] In an aspect of the present disclosure, an ultrasound system includes an ultrasound probe, a processing unit, a camera, and a display. The camera captures an organ or body part's surface view and sends the image stream to the processing unit. The ultrasound probe has a detecting system or sensor configured to detect the position and orientation of the ultrasound probe. The ultrasound probe also has an ultrasound scanner config-

ured to generate a plurality of ultrasound images. The processing unit is in communication with the camera, the detecting system, and the ultrasound scanner. The processing unit is configured to create a three-dimensional data set aligned with the surface view from the camera, based on the position and orientation of the ultrasound probe as it swipes across a surface and when each of the plurality of ultrasound images is generated. The display is in communication with the processing unit and configured to output a view of one subsurface layer from the ultrasound probe, overlaid on the surface view from the camera, as the user swipes the ultrasound probe on a tissue surface. It thus creates a virtual peeling off effect on the display as the user swipes. The display is configured to output a subsurface view of a layer of different depth with another intraoperative swipe on the tissue surface by a user. The user controls the depth of the subsurface view by swiping the ultrasound probe in different directions.

[0008] In embodiments, the detecting system may either be a magnetic sensing system or an optical sensing system. A magnetic sensing system includes a positional field generator configured to generate a three-dimensional field. The three-dimensional positional field may be a three-dimensional magnetic field and the sensor may be a magnetic sensor. The positional field generator may be configured to generate the three-dimensional field about a patient or may be configured to generate the three-dimensional positional field from within a body cavity of a patient. The positional field generator may be disposed on a camera or a laparoscope and the sensor may be configured to identify the position and the orientation of the ultrasound probe within the positional field. An optical sensing system includes one or a plurality of markers attached to the end of the ultrasound transducer and the camera. The camera can either be one out of body if the ultrasound probe is used on body surface, or one attached to a laparoscope if the ultrasound probe is used as a laparoscopic tool. The camera communicates the video stream that contains the markers to the processing unit. The processing unit identifies the markers and computes to generate the orientation and position of the ultrasound probe.

[0009] In embodiments, the display is configured to overlay a surface image from the camera and a subsurface image layer from the ultrasound system, and align them with right position and orientation.

[0010] In aspects of the present disclosure, a method for viewing tissue layers includes capturing surface view from a camera, capturing a plurality of ultrasound images of a patient's body part with an ultrasound probe, recording the position and the orientation of the ultrasound probe with a detecting system, creating a three-dimensional data set having a plurality of subsurface layers aligned to the surface view, interoperatively swiping the ultrasound probe across patient's body part to view a subsurface layer on a surface view, and other layers of chosen depth with the swipes.

[0011] In embodiments, creating the three-dimensional data set includes swiping the ultrasound probe across a patient's body part, associating the plurality of ultrasound images with the position and the orientation of the ultrasound probe, and extracting and viewing the layer of interest from the three-dimensional data set. In some embodiments, swiping the ultrasound probe on the body part replaces a first subsurface layer to display a second subsurface layer that is deeper or shallower than the first layer, depending on the swiping directions.

[0012] In particular embodiments, the method includes inserting a surgical instrument into a body cavity of a patient and visualizing the position of the surgical instrument within one of the first and second layers. The method may also include interopertively updating the position of the surgical instrument on the display.

[0013] In certain embodiments, generating views of subsurface layers includes adjusting the thickness of the view by averaging the ultrasound data over specified depth to enhance visualizing certain features like blood vessels.

[0014] The ultrasound system may fill in the gap of ultrasound anatomy between a surgeon and a sonographer enabling a non-invasive method of visualizing a surgical site. In addition, the ultrasound system may provide an intuitive user interface enabling a clinician to use the ultrasound system interopertively.

[0015] Further, to the extent consistent, any of the aspects described herein may be used in conjunction with any or all of the other aspects described herein.

BRIEF DESCRIPTION OF THE DRAWINGS

[0016] Various aspects of the present disclosure are described hereinbelow with reference to the drawings, wherein:

FIG. 1 is a perspective view of an ultrasound system in accordance with the present disclosure including a camera, an ultrasound probe, a positional and orientation detecting system, a processing unit, and a display;

FIG. 2 is a cut-away of the detail area shown in FIG. 1 illustrating the ultrasound probe shown in FIG. 1 and a laparoscope within a body cavity of a patient;

FIG. 3 is a perspective view of a three-dimensional model generated by the processing unit of FIG. 1 illustrating a plurality of subsurface layers;

FIG. 4 is a view of a first layer on the display of FIG. ; and

FIG. 5 is view of a second layer on the display of FIG. 4 deeper within a body cavity of a patient illustrating the ultrasound transducer swipes on the body part to reveal the second layer with a blood vessel.

DETAILED DESCRIPTION

[0017] Embodiments of the present disclosure are now described in detail with reference to the drawings in which like reference numerals designate identical or corresponding elements in each of the several views. As used herein, the term "clinician" refers to a doctor, a nurse, or any other care provider and may include support personnel. Throughout this description, the term "proximal" refers to the portion of the device or component thereof that is closest to the clinician and the term "distal" refers to the portion of the device or component thereof that is farthest from the clinician.

[0018] Referring now to FIG. 1, an ultrasound imaging system 10 provided in accordance with the present disclosure includes a camera 33, a position and orientation detecting system or sensor 14, a processing unit 11, a display 18, and an ultrasonic probe 20. The position and orientation detecting system 14 is configured to detect position and orientation with a sensor or marker attached on the ultrasound probe 20 within a region of interest during a surgical procedure.

[0019] The ultrasound imaging system is configured to provide cross section views and data sets of a region of interest within a body cavity or on body surface of a patient P on the display 18. A clinician may interact with the ultrasound imaging system 10 and laparoscope 16 attached to a camera 33 to visualize surface and subsurface of a body part within the region of interest during a surgical procedure as detailed below.

[0020] The ultrasound imaging system 10 includes an ultrasound scanner or processing unit 11 that is configured to receive a position and an orientation of the ultrasound probe 20 and a plurality of ultrasound images 51 perpendicular to the surface of the body part from the ultrasound probe 20. The processing unit 11 is configured to relate the position and the orientation of the ultrasound probe 20 with each of the plurality of ultrasound images 51 to generate a 3D ultrasound data set. The processing unit then re-organizes the 3D image pixel data to form a view of one layer in parallel to the scan surface. This layer can be one of the layers 31 to 37 as illustrated in FIG3.

[0021] The position and orientation detecting system 14 can either be an optical system that is integrated with the processing unit 11, or a magnetic sensory system that is based on a three-dimensional field. In the optical system case an optical marker 15 is attached on the ultrasound probe, whose position and orientation can be computed with the images captured with camera 33. In the latter case the detecting system 14 has a field generator that generates a three-dimensional field within an operating theater about a patient P. As shown in FIG. 1, the positional field generator is disposed on the surgical table 12 to orientate the patient P within the field. It is within the scope of this disclosure, that the positional field generator is integrated into the surgical table 12. It is also within the scope of this disclosure that the positional field

generator may be positioned anywhere within an operating theater or outside the operating theater. The ultrasound imaging system 10 may include a magnetic sensors 15 adhered to the ultrasound probe 20 such that the location and orientation of the ultrasound probe 20 may be used by the processing unit 11 to align the collected three-dimensional data set 30 to the surface view captured by camera 33. An exemplary embodiment of such a magnetic sensing system is disclosed in commonly owned U.S. Patent Application Serial No. 11/242048, filed November 16, 2010, and now published as U.S. Patent No. United States Patent 7835785, the contents of which are hereby incorporated in its entirety.

[0022] With reference to FIG. 2, the ultrasound probe 20 is adjacent to an outer tissue layer 31 of the patient P. The ultrasound probe 20 includes an ultrasound scanner 22, a position sensor 24, and an orientation sensor 25. The ultrasound scanner 22 is configured to generate and transmit a plurality of ultrasound images of the region of interest to the processing unit 11 (FIG. 1). The processing unit 11 receives the plurality of ultrasound images and receives the position and the orientation of the ultrasound scanner 22 within the field generated by the positional field generator 14 from the position sensor 24 and the orientation sensor 25 at the time each of the plurality of ultrasound images was generated to create a plurality of ultrasound frames. It is also within the scope of this disclosure that the functions of the position sensor 24 and the orientation sensor 25 may be integrated into a single sensor.

[0023] It is also within the scope of this disclosure that the plurality of orientation sensors 15, the position sensor 24, and the orientation sensor 25 are image markers whose positioned and orientation may be detected by the positional field generator 14 or a laparoscope. Exemplary embodiments of image markers and positional field generators are disclosed in commonly owned U.S. Patent No. 7,519,218, the contents of which are hereby incorporated in its entirety.

[0024] In some embodiments, the surgical instrument 16 includes a positional field generator 17 (FIG. 2) that is configured to generate a three-dimensional positional field within a body cavity of the patient P. The sensors 24, 25 identify the position and the orientation of the ultrasound scanner 22 within the three-dimensional positional field generated by the positional field generator 17. It is also contemplated that the position and the orientation of the sensors 24, 25 within the three-dimensional positional fields generated by both positional field generators 14, 17 may be transmitted to the processing unit 11.

[0025] With reference to FIG. 3, the processing unit 11 utilizes an image reconstruction algorithm to create a three-dimensional model 30 of the region of interest having a plurality of layers 31-37 that are parallel to the outer surface of the region of interest (i.e., the outer tissue layer 31 of the patient P) from the plurality of ultrasound frames. The processing unit 11 includes an adaptive penetration

algorithm that highlights layers within the three-dimensional model 30 that include rich structures (e.g., blood vessels, surfaces of internal organs, etc.). The adaptive penetration algorithm may adjust the thickness of predefined selectable layers 31-37 based on the rich structures within the body cavity (e.g., organs or dense tissue layers). It will be understood that layer 31 may be a surface layer and layers 32-33 may be subsurface layers. An example of this process is when a blood vessel is located in a layer, for example, layer 34 that is not perfectly in parallel to the outer surface 31. In this case the processing unit 11 detects the location of the blood vessel based on the cross section B-mode view 51, and extract layer 34 out of the three-dimensional data set, and reconstruct an image layer that specifically includes the blood vessel to show on display 18. The depth and thickness of the layer 34 is adaptively adjusted based on the detected vessel location.

[0026] With reference to FIGS. 4 and 5, the display 18 displays a surface view captured by the camera 33, and a subsurface layer view from the processing unit 11 aligned and overlaid to the surface view. The subsurface view is one of the layers 31-37 of the three-dimensional data set 30. The processing unit 11 is configured to detect the movement of the ultrasound probe in a surgical procedure to change the layer 31-37 that is displayed. The display 18 may be configured to enlarge or shrink areas of detail in response to input from a clinician.

[0027] With reference to FIGS. 1-5, a method for viewing tissue layers within a patient may be used to position the surgical instrument 16 adjacent a blood vessel V in tissue layer 33. The ultrasonic probe 20 is positioned within the or adjacent to the region of interest to capture a plurality of ultrasonic images of the region of interest within a patient with the ultrasonic scanner 22. The position and orientation of the ultrasonic scanner 22 is recorded with each of the plurality of ultrasound images in the processing unit 11 to create a plurality of image frames. The processing unit 11 creating a plurality of subsurface layers 31-37 parallel to an outer tissue surface of the patient P from the plurality of image frames and outputting a first one of the plurality of layers (e.g., layer 32 as shown in FIG. 4) on the display 18. The clinician may then swipe across the display to view a second, deeper, layer within the region of interest (e.g., layer 33 as shown in FIG. 5). During a surgical procedure, the clinician may insert a surgical instrument into the region of interest while using the ultrasound imaging system 10 to visualize the position of the surgical instrument within the body cavity. As the surgical instrument is repositioned within the region of interest, the position of the surgical instrument is updated on the display 18.

[0028] While several embodiments of the disclosure have been shown in the drawings, it is not intended that the disclosure be limited thereto, as it is intended that the disclosure be as broad in scope as the art will allow and that the specification be read likewise. Any combination of the above embodiments is also envisioned and is with-

in the scope of the appended claims. Therefore, the above description should not be construed as limiting, but merely as exemplifications of particular embodiments. Those skilled in the art will envision other modifications within the scope and spirit of the claims appended hereto.

[0029] The invention may be described by reference to the following numbered paragraphs:-

1. A ultrasound system comprising:

an ultrasound probe including;
 a sensor configured to provide the position and the orientation of the ultrasound probe; and
 an ultrasound scanner configured to generate a plurality of ultrasound images;
 a processing unit in communication with the sensor and the ultrasound scanner, the processing unit configured to create a three-dimensional model from the position and the orientation of the ultrasound probe when each of the plurality of ultrasound images is generated; and
 a display configured to output a view of a first layer of the three-dimensional model and configured to output a view of a second layer of the three-dimensional model different from the first layer in response to an intraoperative swipe across the display by a user.

2. The ultrasound system of paragraph 1, wherein the first and second layers are parallel to one another.

3. The ultrasound system of paragraph 1, wherein the second layer is a subsurface layer deeper than the first layer.

4. The ultrasound system of paragraph 1 further including a positional field generator configured to generate a three-dimensional field about a patient.

5. The ultrasound system of paragraph 4, wherein the positional field generator generates a three-dimensional magnetic field.

6. The ultrasound system of paragraph 1, wherein the sensor is a magnetic sensor.

7. The ultrasound system of paragraph 1, wherein the sensor is a marker disposed on the ultrasound probe.

8. The ultrasound system of paragraph 7 further including a laparoscope including a positional field generator configured to generate a three-dimensional positional field within a body cavity of a patient, the sensor configured to identify the position and the orientation of the ultrasound probe within the posi-

tional field.

9. The ultrasound system of paragraph 1, wherein the display includes a sensor configured to detect an intraoperative swipe across the display.

10. The ultrasound system of paragraph 1, wherein the display is a touch screen display configured to detect an intraoperative swipe across the display.

11. A method for viewing tissue layers comprising:

capturing a plurality of ultrasound images of a body cavity of a patient with an ultrasound probe;
 recording the position and the orientation of the ultrasound probe with a sensor;
 creating a three-dimensional model having a plurality of subsurface layers;
 viewing a first layer of the plurality of subsurface layers on a display; and
 interopertively swiping across the display to view a second layer of the plurality of subsurface layers different from the first layer.

12. The method of paragraph 11, wherein generating the three-dimensional model includes associating the plurality of ultrasound images with the position and the orientation of the ultrasound probe.

13. The method of paragraph 11, wherein swiping the display peels off the first layer of the plurality of subsurface layers to display the second layer that is deeper than the first layer.

14. The method of paragraph 11 further including inserting a surgical instrument into a body cavity of a patient and visualizing the position of the surgical instrument within at least one of the first and second layers.

15. The method of paragraph 14 further including interopertively updating the position of the surgical instrument on the display.

16. The method of paragraph 11, wherein creating a plurality of subsurface layers includes adjusting thickness of at least one of the plurality of subsurface layers in response to biological structures within a body cavity of a patient.

Claims

1. A ultrasound system comprising:

an ultrasound probe including;
 a sensor configured to provide the position and the orientation of the ultrasound probe; and

- an ultrasound scanner configured to generate a plurality of ultrasound images;
 a processing unit in communication with the sensor and the ultrasound scanner, the processing unit configured to create a three-dimensional model from the position and the orientation of the ultrasound probe when each of the plurality of ultrasound images is generated; and
 a display configured to output a view of a first layer of the three-dimensional model and configured to output a view of a second layer of the three-dimensional model different from the first layer in response to an intraoperative swipe across the display by a user.
- 5
- 10
- 15
- 20
- 25
- 30
- 35
- 40
- 45
- 50
- 55
11. A method for viewing tissue layers comprising:
 capturing a plurality of ultrasound images of a body cavity of a patient with an ultrasound probe;
 recording the position and the orientation of the
- ultrasound probe with a sensor;
 creating a three-dimensional model having a plurality of subsurface layers;
 viewing a first layer of the plurality of subsurface layers on a display; and
 interoperatively swiping across the display to view a second layer of the plurality of subsurface layers different from the first layer.
12. The method of claim 11, wherein generating the three-dimensional model includes associating the plurality of ultrasound images with the position and the orientation of the ultrasound probe.
13. The method of claim 11 or claim 12, wherein swiping the display peels off the first layer of the plurality of subsurface layers to display the second layer that is deeper than the first layer.
14. The method of any of claims 11 to 13 further including inserting a surgical instrument into a body cavity of a patient and visualizing the position of the surgical instrument within at least one of the first and second layers.
15. The method of claim 14 further including interoperatively updating the position of the surgical instrument on the display.
16. The method of any of claims 11 to 15, wherein creating a plurality of subsurface layers includes adjusting thickness of at least one of the plurality of subsurface layers in response to biological structures within a body cavity of a patient.

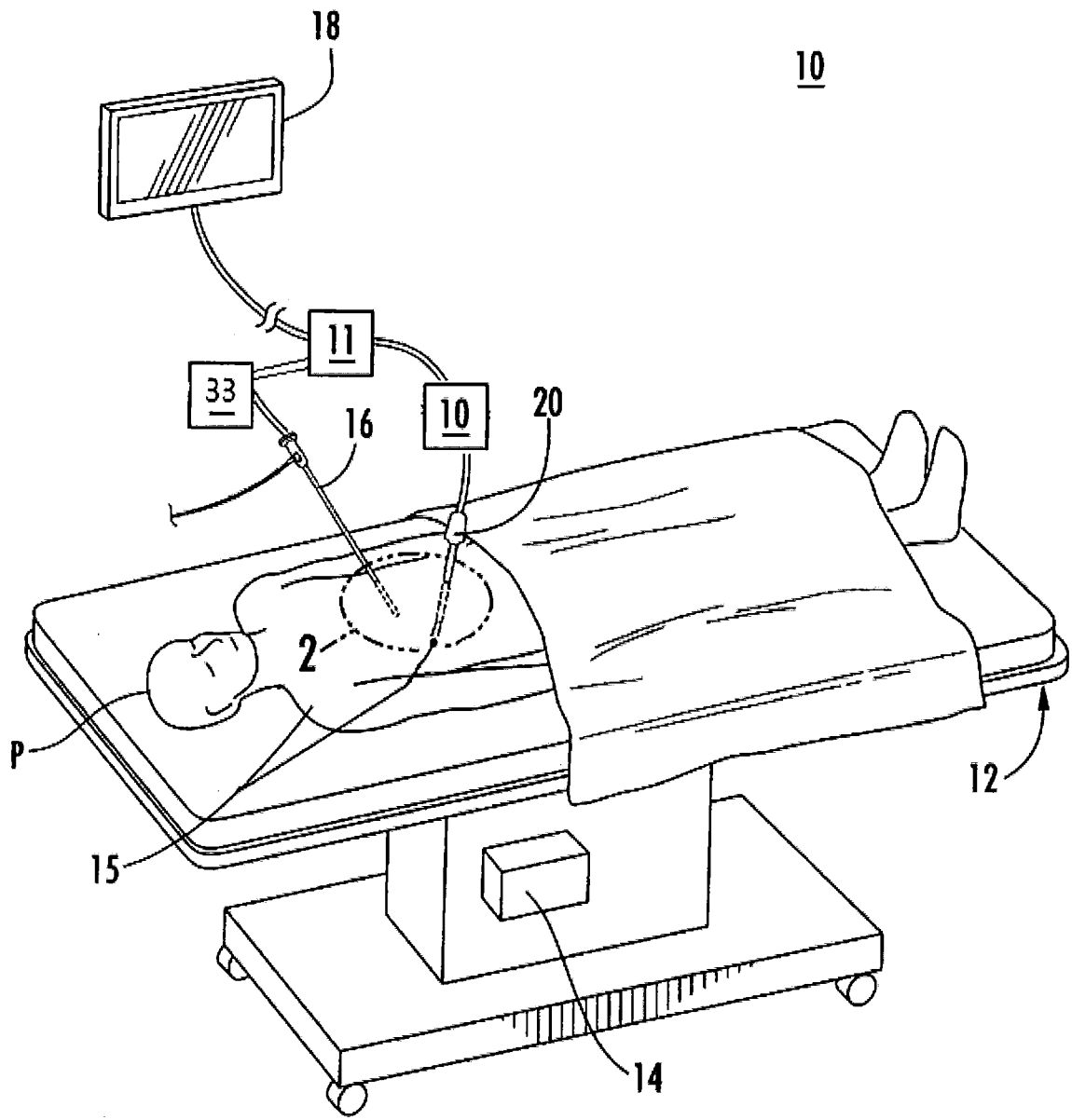

FIG. 1

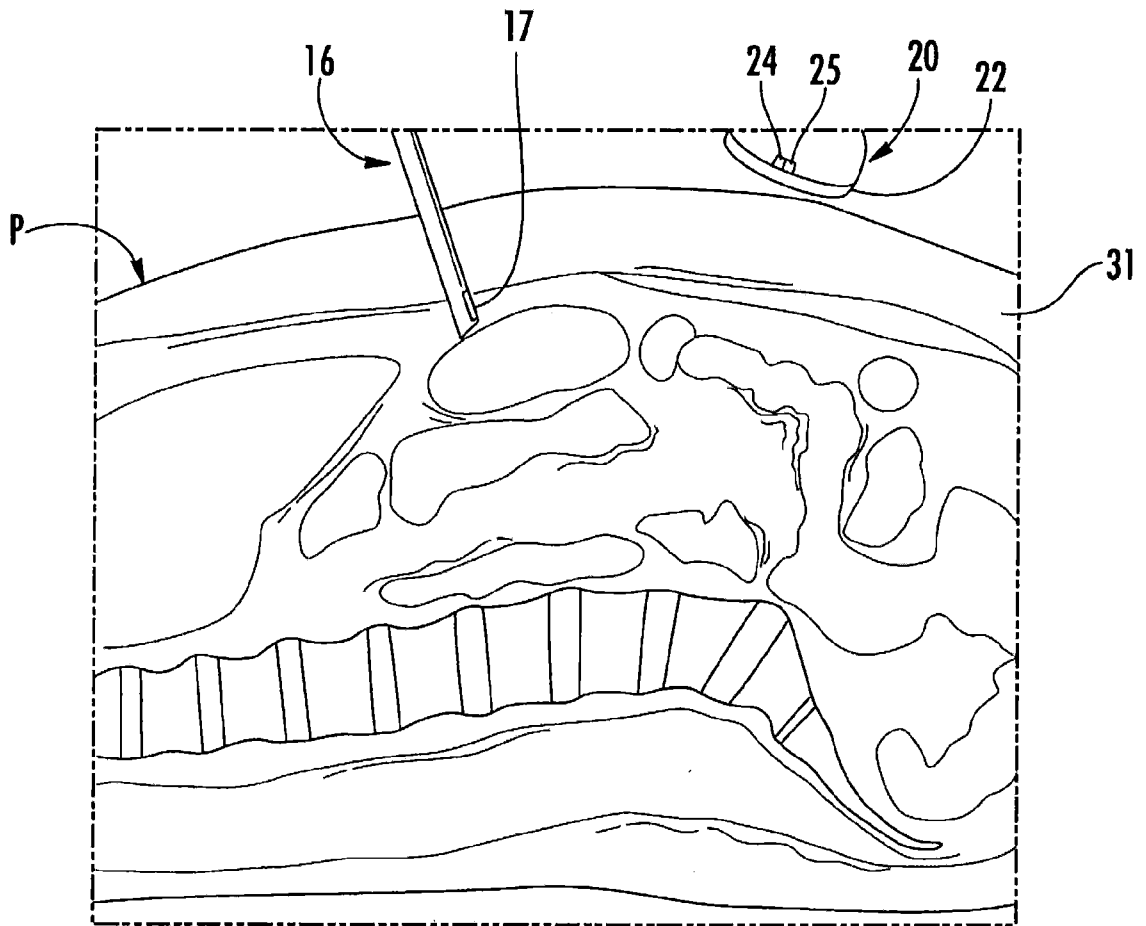

FIG. 2

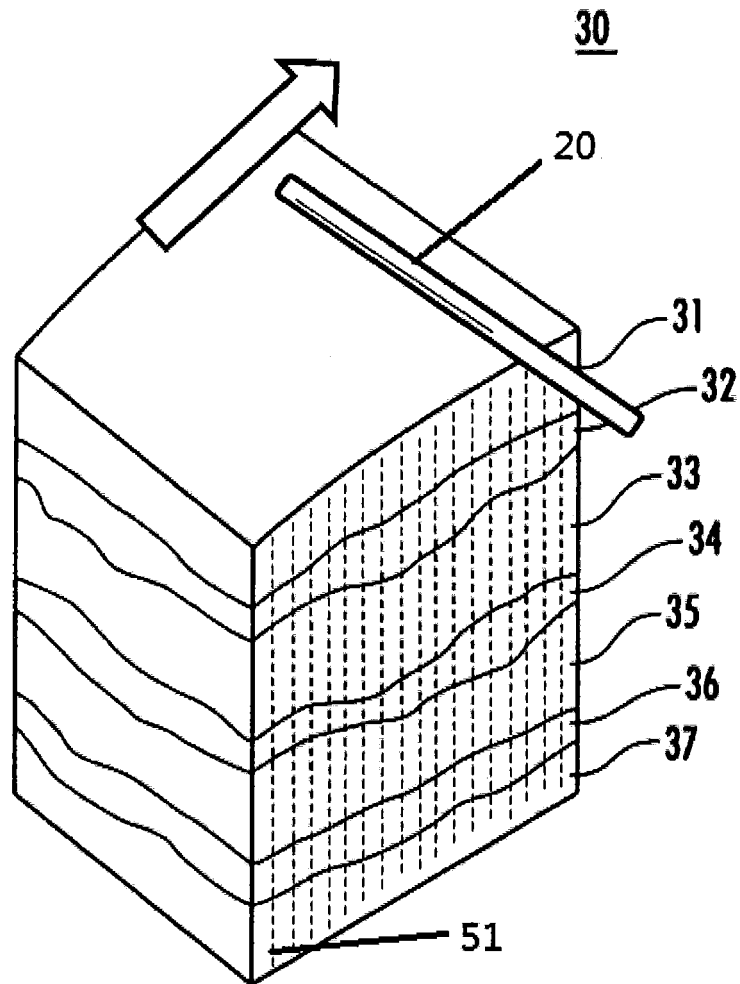

FIG. 3

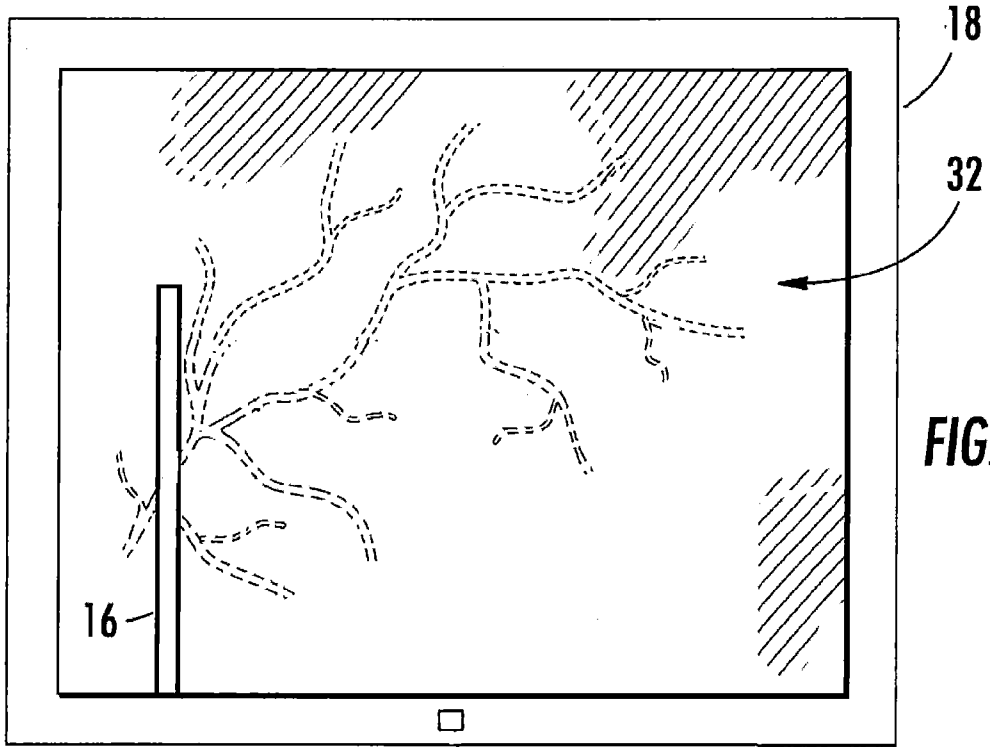

FIG. 4

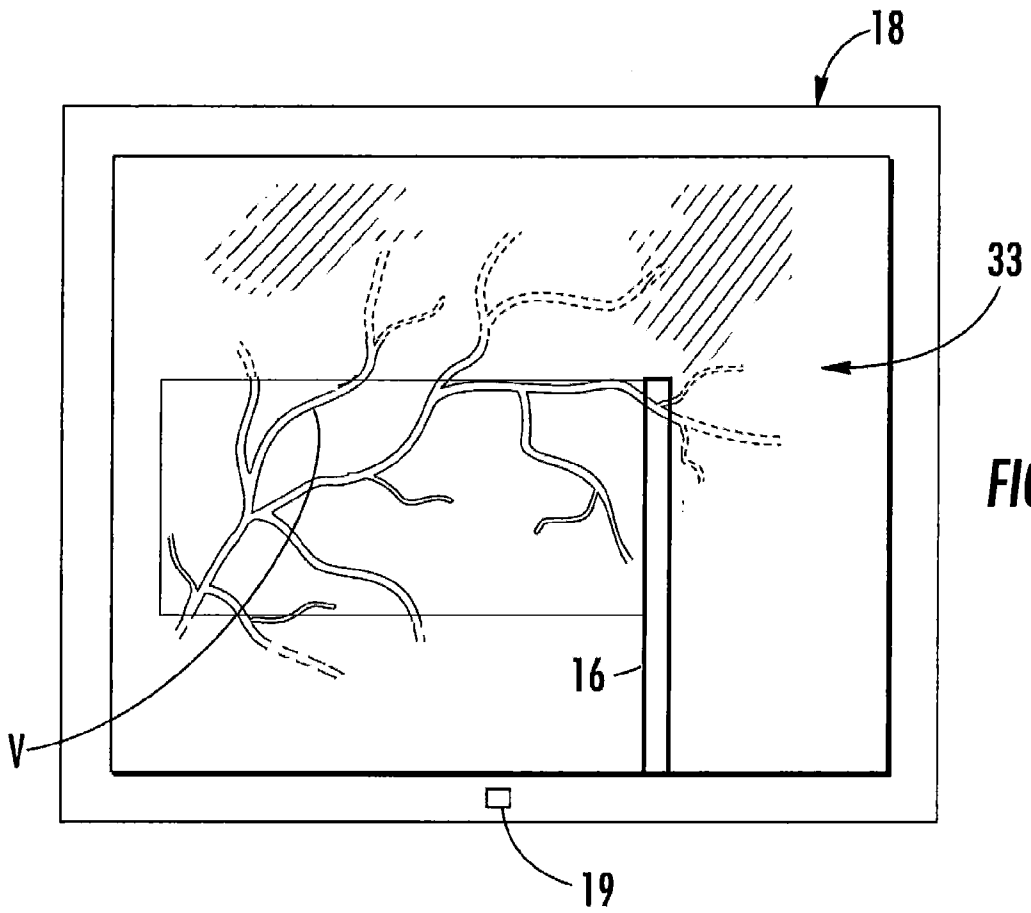

FIG. 5



EUROPEAN SEARCH REPORT

Application Number
EP 15 17 1422

5

10

15

20

25

30

35

40

45

50

55

DOCUMENTS CONSIDERED TO BE RELEVANT			
Category	Citation of document with indication, where appropriate, of relevant passages	Relevant to claim	CLASSIFICATION OF THE APPLICATION (IPC)
A	STETTEN G ET AL: "C-Mode Real-time Tomographic Reflection for a Matrix Array Ultrasound Sonic Flashlight<1>", ACADEMIC RADIOLOGY, RESTON, VA, US, vol. 12, no. 5, 1 May 2005 (2005-05-01), pages 535-543, XP027798842, ISSN: 1076-6332 [retrieved on 2005-05-01] * page 539, column 2, paragraph 2 - page 541, column 1, paragraph 3; figures 7-9, 13 *	1-16	INV. A61B8/12 A61B8/00 A61B8/08
A	----- US 2010/268086 A1 (WALKER WILLIAM F [US] ET AL) 21 October 2010 (2010-10-21) * paragraph [0026] *	1-16	
A	----- US 2012/157842 A1 (DAVIS CYNTHIA ELIZABETH LANDBERG [US] ET AL) 21 June 2012 (2012-06-21) * paragraph [0004] - paragraph [0043]; figures 10,13 *	1-16	
			TECHNICAL FIELDS SEARCHED (IPC)
			A61B
The present search report has been drawn up for all claims			
Place of search Munich		Date of completion of the search 6 October 2015	Examiner Martinez Möller, A
CATEGORY OF CITED DOCUMENTS X : particularly relevant if taken alone Y : particularly relevant if combined with another document of the same category A : technological background O : non-written disclosure P : intermediate document		T : theory or principle underlying the invention E : earlier patent document, but published on, or after the filing date D : document cited in the application L : document cited for other reasons & : member of the same patent family, corresponding document	

EPC FORM 1503 03.82 (P04001)

**ANNEX TO THE EUROPEAN SEARCH REPORT
ON EUROPEAN PATENT APPLICATION NO.**

EP 15 17 1422

5

This annex lists the patent family members relating to the patent documents cited in the above-mentioned European search report. The members are as contained in the European Patent Office EDP file on The European Patent Office is in no way liable for these particulars which are merely given for the purpose of information.

06-10-2015

10

Patent document cited in search report	Publication date	Patent family member(s)	Publication date
US 2010268086 A1	21-10-2010	AT 481033 T	15-10-2010
		AU 2003220001 A1	22-09-2003
		CA 2478085 A1	18-09-2003
		EP 1549221 A1	06-07-2005
		US 2005154303 A1	14-07-2005
		US 2010268086 A1	21-10-2010
		US 2015011884 A1	08-01-2015
		WO 03075769 A1	18-09-2003

US 2012157842 A1	21-06-2012	BR PI1105359 A2	09-04-2013
		CN 102580260 A	18-07-2012
		US 2012157842 A1	21-06-2012

15

20

25

30

35

40

45

50

55

EPO FORM P0459

For more details about this annex : see Official Journal of the European Patent Office, No. 12/82

REFERENCES CITED IN THE DESCRIPTION

This list of references cited by the applicant is for the reader's convenience only. It does not form part of the European patent document. Even though great care has been taken in compiling the references, errors or omissions cannot be excluded and the EPO disclaims all liability in this regard.

Patent documents cited in the description

- US 62010608 A [0001]
- US 24204810 A [0021]
- US 7835785 B [0021]
- US 7519218 B [0023]

专利名称(译)	滑动以查看超声成像以了解术中应用		
公开(公告)号	EP2954846A1	公开(公告)日	2015-12-16
申请号	EP2015171422	申请日	2015-06-10
[标]申请(专利权)人(译)	柯惠有限合伙公司		
申请(专利权)人(译)	COVIDIEN LP		
当前申请(专利权)人(译)	COVIDIEN LP		
[标]发明人	TAN WEI		
发明人	TAN, WEI		
IPC分类号	A61B8/12 A61B8/00 A61B8/08		
CPC分类号	A61B8/0841 A61B8/0858 A61B8/0891 A61B8/12 A61B8/4245 A61B8/4254 A61B8/4444 A61B8/463 A61B8/466 A61B8/467 A61B8/483 A61B8/5207		
优先权	62/010608 2014-06-11 US 14/702976 2015-05-04 US		
其他公开文献	EP2954846B1		
外部链接	Espacenet		

摘要(译)

超声系统具有超声探头，处理单元和显示器。超声探头包括：传感器，被配置为检测超声探头的位置和取向；以及超声扫描器，被配置为生成多个超声图像。处理单元与传感器和超声扫描仪通信，并且被配置为当生成多个超声图像中的每一个时，根据超声探头的位置和取向来创建三维模型。显示器与处理单元通信并且被配置为输出三维模型的第一层的视图并且被配置为响应于跨越显示器的术中滑动而输出三维模型的第二层的视图。一个用户。

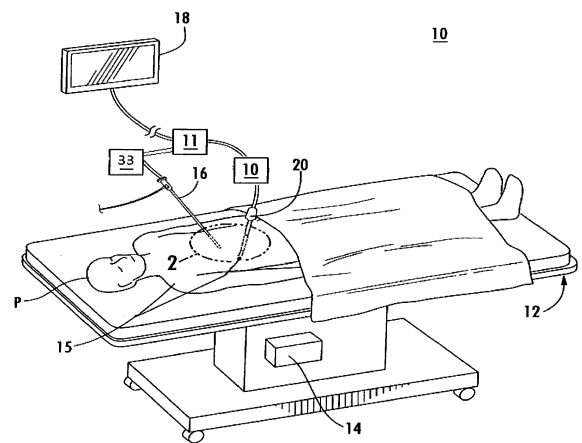

FIG. 1