

(19)



(11)

**EP 2 568 883 B1**

(12)

**EUROPEAN PATENT SPECIFICATION**

(45) Date of publication and mention of the grant of the patent:  
**15.11.2017 Bulletin 2017/46**

(51) Int Cl.:  
**A61B 8/00** (2006.01)      **A61B 5/00** (2006.01)  
**G10K 11/34** (2006.01)      **G01S 7/52** (2006.01)  
**G01S 15/89** (2006.01)

(21) Application number: **11725965.5**

(86) International application number:  
**PCT/IB2011/052000**

(22) Date of filing: **05.05.2011**

(87) International publication number:  
**WO 2011/138758 (10.11.2011 Gazette 2011/45)**

**(54) A METHOD AND AN APPARATUS FOR ULTRASOUND IMAGE ACQUISITION**

VERFAHREN UND VORRICHTUNG ZUR AUFNAHME VON ULTRASCHALLBILDERN  
PROCÉDÉ ET APPAREIL D'ACQUISITION D'IMAGES ULTRASONORES

(84) Designated Contracting States:  
**AL AT BE BG CH CY CZ DE DK EE ES FI FR GB GR HR HU IE IS IT LI LT LU LV MC MK MT NL NO PL PT RO RS SE SI SK SM TR**

(56) References cited:  
**EP-A1- 2 053 418      US-A1- 2002 016 545**  
**US-A1- 2003 139 664      US-A1- 2008 114 253**

(30) Priority: **07.05.2010 IT GE20100048**  
**07.05.2010 IT GE20100047**

- **ELLIS M A ET AL: "Reduced rank formulation for increased computational efficiency in medical ultrasound model-based beamforming", SIGNALS, SYSTEMS AND COMPUTERS, 2008 42ND ASIOMAR CONFERENCE ON, IEEE, PISCATAWAY, NJ, USA, 26 October 2008 (2008-10-26), pages 1923-1926, XP031475640, ISBN: 978-1-4244-2940-0**
- **FRANCESCO VIOLA ET AL: "Time-Domain Optimized Near-Field Estimator for Ultrasound Imaging: Initial Development and Results", IEEE TRANSACTIONS ON MEDICAL IMAGING, IEEE SERVICE CENTER, PISCATAWAY, NJ, US, vol. 27, no. 1, 1 January 2008 (2008-01-01), pages 99-110, XP011195368, ISSN: 0278-0062, DOI: DOI:10.1109/TMI.2007.903579**

(43) Date of publication of application:  
**20.03.2013 Bulletin 2013/12**

(73) Proprietor: **Esaote S.p.A.**  
**16152 Genova (IT)**

(72) Inventor: **CEROFOLINI, Marino**  
**I-52010 Subbiano (AR) (IT)**

(74) Representative: **Karaghiosoff, Giorgio**  
**Alessandro**  
**Studio Karaghiosoff e Frizzi S.r.l.**  
**Via F. Baracca 1R 4° piano**  
**17100 Savona (IT)**

Note: Within nine months of the publication of the mention of the grant of the European patent in the European Patent Bulletin, any person may give notice to the European Patent Office of opposition to that patent, in accordance with the Implementing Regulations. Notice of opposition shall not be deemed to have been filed until the opposition fee has been paid. (Art. 99(1) European Patent Convention).

**EP 2 568 883 B1**

## Description

**[0001]** The present invention relates to a method for ultrasound image acquisition according to the preamble of claim 1 and to an apparatus for ultrasound image acquisition integrated into the casing of an ultrasound probe for ultrasound imaging apparatuses according to the preamble of claim 14.

**[0002]** Ultrasound probes comprises an array of electroacoustic transducers, each one of which transmitting ultrasound waves when powered with an electric excitation signal and generating an electric reception signal when impinged by an ultrasound wave or pulse generated for example by the reflection of ultrasound waves transmitted therefrom;

said array of electroacoustic transducers being provided with at least a communication line to a processing unit through which each transducer of said array of transducers feeds reception signals to a processing unit, and with a communication line through which the electric excitation signals generated by a generating unit are fed to each transducer of said array of transducers for exciting the transducer to transmit ultrasound waves;

said generating unit comprising excitation signal generating means and means for feeding said signals to said array of transducers.

**[0003]** The structure described above is a typical structure of a so called ultrasound probe, particularly of ultrasound probes used for ultrasound diagnostic imaging. Generally ultrasound transducers are piezoelectric elements, typically elements made of ceramic material, where oscillations of the crystal lattice are generated upon excitation with an electric potential, which generate mechanical waves in the frequency range of ultrasound acoustic waves. The frequency of the waves and the shape and the spectral composition of the ultrasound waves generated depends on the frequency, shape and spectral composition of the electric excitation pulse.

**[0004]** Typical ultrasound probes of the prior art are therefore composed of a structure as described hereinbefore and are connected to a remote display unit that allows signals transmitted from the probe to be displayed, stored and processed and at the same time it acts for powering the probe.

**[0005]** The invention provides a highly portable probe that does not have cable connections to a remote display unit: several attempts have been made in order to produce a probe of this type, generally two types are the most investigated types.

**[0006]** With reference to a first type, the idea of making ultrasound diagnoses with a wireless probe has been faced by providing a real portable ultrasound apparatus having a compact size with respect to conventional ones such that the user can easily use it with one hand.

**[0007]** With reference to a further type an attempt was made to integrate the beamformer into the probe then transmitting the obtained data to a remote display unit, such as an ultrasound apparatus, by radio frequency sig-

nals.

**[0008]** However in both the above cases the apparatuses have considerable dimensions, have usage problems and moreover the quality of the reconstructed image is considerably poorer than that generated by conventional ultrasound apparatuses.

**[0009]** Document US2002/016545 discloses an apparatus for ultrasound image acquisition integrated into the casing of an ultrasound probe for ultrasound imaging apparatuses according to the preamble of claim 15.

**[0010]** Document US2003/139664 discloses a portable segmented hand held ultrasound system. Ultrasound data such as image data in video format is wirelessly transmitted to a multi-use display device.

**[0011]** Document EP2053418 teaches the performing of a beamforming taking into account a plurality of transmission pulses emitted from different emission points of the transducer array. Elements in an ultrasound array are activated according to a transmit beamformer to create a series of transmit beams. For each transmit beam, the first stage of a receive beamformer determines a plurality of primary receive beams. A second beamformer stage then computes secondary receive beams as a function of the primary receive beams that correspond to return signals from different transmit beams to a common receive beam origin. For example, each secondary receive beam may be calculated as a function of the weighted, time-delayed sum of the primary receive beams. At least one of the secondary receive beams is then output from the beamformer to be used in creating a displayed image

**[0012]** Documents Reduced rank formulation for increased computational efficiency in medical ultrasound model-based beamforming, Ellis M.A. et al.. Signals, Systems and Computers, 2008 42nd Asilomar Conference on IEEE, Piscataway, NJ, USA, 26 October 2008 and Framncesco Viola et al.: Time domain Optimized Near-field Estimator for Ultrasound Imaging: Initial Development and Results, IEEE Transactions on Medical Imaging, IEEE Services Center Piscataway, NJ, US, vol.27, no.1, 1 January 3008, pages 99-110 disclose a beamforming algorithm based on the definition of a grid of preset reflection points in the scan plane and the setting of reflection signals from the reflection points of the said grid.

**[0013]** Document US2008/114253 discloses a method and a system and a device for conduction ultrasound interrogation of a medium. The method includes transmitting a non-beamformed or a beamformed ultrasound wave into the medium, receiving more than one echoed ultrasound wave from the medium and converting the received echoed ultrasound wave into digital data. The document compares to each other specific properties of plane waves and of spherical waves.

**[0014]** Therefore there is the unsatisfied need of producing an ultrasound probe, for ultrasound imaging apparatuses, particularly for diagnostic purposes that, by relatively simple and inexpensive arrangements, allows

the probe and a remote display unit to communicate in a wireless mode in order to facilitate the ultrasound imaging examination procedure without creating obstacles or limitations for the presence of communication cables between the probe and the remote units.

**[0015]** The invention achieves the above aims by providing an ultrasound imaging method comprising the combination of features of the preamble of claim 1 and of the characterising part of claim 1.

**[0016]** The invention provides also for an apparatus for ultrasound image acquisition integrated into the casing of an ultrasound probe for ultrasound imaging apparatuses comprising the combination of features of the preamble and of the characterising part of claim 14.

**[0017]** By the provision of converting means into the processing unit that receive said reception signals and convert them into image data which are transmitted to video signal generating means acting for converting such data into a video signal, the processed data occupy a frequency band for the transmission very lower than that of conventional ultrasound images and therefore they can be easily transmitted in the wireless mode.

**[0018]** With reference to all the known solutions used up to now, the received data are processed outside the probe and therefore the transmission from the probe to a remote display unit, by means of wireless protocols, involves raw received data: in this case the bandwidth necessary for transmitting such data is very high, therefore such systems do not found a real practical use as the transmission is too slow. This for example occurs in the apparatus described in US2002/0016545. In this document the image data are obtained by using conventional ultrasound image forming technologies, therefore the miniaturization has a limit of some kilos (about 5 pounds). In order to reduce the weight and the dimensions by using the known ultrasound technologies, the apparatus provides to convert the reception signals into raw signals which are transmitted to the remote unit in order to be further processed as an image and therefore in order to be displayed.

**[0019]** According to a preferred improvement of the invention that allows dimensions and weights of the processing unit to be reduced to the typical size of ultrasound probes and therefore less than 500 grams, the processing means is defined as in claim 14.

**[0020]** According to a further characteristic the image forming storage comprises one or more storage cells where image data are stored for each set of reflection signals from the individual reflection points of said grid of predetermined reflection points, so that said processing means generate a single final image by summing the image data concerning each set of reflection signals contained in the corresponding storage cells, each storage cell being univocally associated to an image pixel.

**[0021]** By means of a configuration as the one described above it is advantageous for each storage cell to be univocally associated to a reflection point of the grid of the reflection points and the components of the recep-

tion signals corresponding to the reflection signals concerning said reflection point are stored therein, which components are determined by the time reception windows each one calculated for the reception of the reflection signal from a predetermined reflection point of the grid of the reflection points.

**[0022]** The improvements described above operate according to an image forming method according to claim 1. According to a further improvement of the apparatus of the present invention, there are provided means for determining a sub-grid, smaller than said grid, whose peripheral points coincide with at least part of the points of said grid, said sub-grid being composed of as many points as those contained in said grid in the area delimited by the peripheral points of said sub-grid or more.

**[0023]** In a further embodiment the sub-grid is composed of as many points as those contained in the grid, since it is optimized for the computing power of the processing means.

**[0024]** According to a further embodiment there is provided a user interface for displaying the image or video so obtained and for setting the perimeter of the sub-grid, a computational algorithm being provided for automatically defining the internal points of said sub-grid.

**[0025]** Therefore the user can make a first scanning obtaining an image or a series of images or videos, can decide the region of interest where making a more detailed imaging, and by means of said user interface the user can launch said computational algorithm that automatically defines the internal points of said sub-grid.

**[0026]** Thus the following acquisitions are limited to the region of interest, with a more detailed level than the first acquisition due to the smaller dimensions of the region of interest and due to the fact the same number of reflection points under examination is contemporaneously maintained.

**[0027]** The apparatus can also have further advantageous characteristics as regards functional and constructional point of view in order to obtain an ultrasound system composed of a probe with a substantially conventional shape and weight, wherein the electronic components scanning and forming the image from the conversion of received data into finished image data are integrated and which probe communicates by a wireless transmission with a remote unit displaying/storing the images.

**[0028]** It is possible to use any type of protocol of the transmission and reception means in a preferred embodiment the transmission and reception is of the radio wave type called "wi-fi".

**[0029]** Preferably each transducer, of the array of transducers, is connected to the processing unit and to the generating unit by a switch, which has two conditions, an operating condition, enabling each transducer to receive/transmit electric excitation signals, and a non-operating condition, disabling each transducer from receiving/transmitting electric excitation signals, respectively. The transition from the operating condition to the non-

operating condition being set by the processing unit that alternates the reception/transmission of each individual transducer according to specific time sequences that are different for each individual transducer.

**[0030]** In this case the processing unit can be composed of storage devices and of one or more programmable components able to control the operating process, to synthesize waveforms for exciting the transducers and to combine the components of the reception signals according to appropriate rules in order to directly obtain image data. The processing unit therefore can manage both the storage of reception signals of the individual transducers in suitable storage devices and the reading of the stored reception signals.

**[0031]** According to a preferred embodiment, the ultrasound probe of the present invention, provides the use of means for powering electronic circuits which are composed of a power generating and storing source, as a battery or the like, provided in combination with and connected to circuits matching and connecting the battery to the electric signal generating, communicating and processing means. Such improvement is particularly advantageous, since it allows the probe of the present invention to be made independent from any type of power supply obtained by a physical connection to any external network, enhancing the fact that the probe is independent from any other apparatus both power supply apparatuses, due to the use of the battery, or remote display equipment, due to the use of wireless communication means.

**[0032]** It has to be noted that such power means are obviously provided within the probe and it will be widely described below how the battery is housed within the casing of the probe.

**[0033]** It is possible to provide within the probe also the unit generating the transmission signals to be sent in order to excite the transducers: such signals are preferably time-varying frequency signals, the transmitted ultrasound pulses being encoded by frequency variations over time according to a specific function over time such as for example a linear or non-linear function. In particular "CHIRP" signals are generated whose frequency variation over time allows high quality images to be obtained even by drastically reducing the number of transmission and reception channels between the transducer array and the signal generating and processing units reducing the overall dimensions of the probe and thus facilitating the use thereof.

**[0034]** The choice of arranging the means communicating, feeding, processing and generating the received and/or transmitted signals into the probe inevitably leads to problems in the size of the probe, therefore the ultrasound probe of the present invention according to a preferred embodiment has a particular and characteristic structure allowing all the means described above to be housed therein while being easy to be used as the conventional probes, and also improving the handling thereof by removing obstacles, if any, when moving it, that are due to the presence of cables for the connection to ex-

ternal units.

**[0035]** The probe casing that houses all the elements described above is composed of a case comprising two narrower and longer side faces and two wider and longer faces, parallel each other and oriented lengthwise in the direction of a longitudinal axis along the direction of propagation of the acoustic beam transmitted from the probe. Moreover there are provided two boards that are parallel or substantially parallel to the wider faces on which boards the circuits feeding, generating and processing the transmitted and/or received signals are arranged.

**[0036]** Such boards are supported by supporting means, allowing the boards to be arranged parallel to each other and allowing also a region housing the power storing and/or generating means to be formed: for example it is possible to provide an intermediate supporting frame that keep the boards spaced apart and that allows the battery to be housed in the space between the two boards. Preferably the frame is composed of a peripheral rim having a thickness substantially corresponding to the thickness of the battery and/or to the gap between the two boards, such rim delimits a central space between the two boards for housing the battery: in this case there is provided a plate closing at least one of the open sides of the frame allowing the frame to rest on said plate such to form the bottom of the housing space that comprises the contacts for the connection between the battery and the boards such to power the means generating and processing the transmitted and/or received signals that are provided on the boards.

**[0037]** Preferably the means feeding, generating and processing the transmitted and/or received signals are made as printed electric circuits on the two boards, fastened to the frame, that are oriented parallel to the larger faces of the probe casing.

**[0038]** According to an improvement of the ultrasound probe according to the present invention both the processing unit and the generating unit can comprise processor means executing a logic program processing, transmitting and receiving signals and a storage unit intended to store the program, the data for executing the program and the data resulting from the execution.

**[0039]** Preferably the processing unit is composed of a FPGA device (Field Programmable Gate Array) that receives the signals of the transducers by an analog/digital converter that transforms the input signals of the FPGA device into digital data such that they can be processed by said device.

**[0040]** Moreover such device has the great advantage of being programmable and the user can modify the program, by changing the task of the probe depending on the needs required by the type of examination to be performed.

**[0041]** Therefore it is necessary to provide a user interface allowing the FPGA to be programmed for manually controlling the scanning parameters: in this case the wireless communication means receive from such interface control signals and/or codes for programming and

setting the operational conditions of the processing and generating units.

**[0042]** Such interface can be directly mounted on the probe, or, as it will be described below, can belong to a remote display unit that sends, in a wireless mode, the control signals to the communication means.

**[0043]** The transducer array and the wireless communication means are fastened at the ends of the boards respectively: there are provided contacts for the communication with the transducer array and with the wireless communication means, which are composed of a plug connector a first part of which cooperating with a corresponding second part.

**[0044]** The contacts of the first part of the plug connector are fastened to the inputs and/or outputs of the array of transducers and to inputs and/or outputs of the wireless communication means respectively and the contacts of the second part are at the ends of the two boards, such that both the transducer array and the wireless communication means are connected to the means feeding, generating and processing the transmitted and/or received signals.

**[0045]** A variant embodiment of the present invention provides the transducer array and/or the wireless communication means to be removably mounted to the probe casing, such that it is possible to use different transducer arrays and/or different communication means while maintaining the same control electronics of the probe. In this case the communication contacts are composed of electric/mechanical connection elements composed in turn of a first part of a plug connector cooperating with a corresponding second part of a plug connector, with the first part fastened to the inputs/outputs of the transducer array and to the input/outputs of the wireless communication means respectively and the second part being fastened to the ends of the two boards and/or to the corresponding shorter and narrower sides of the probe casing.

**[0046]** In this case it is particularly advantageous to provide means for automatically recognizing the type of array of transducers and/or the type of wireless communication means that are used.

**[0047]** Such recognition means can be composed of a logic execution program loaded within the processing unit and for example they can allow the several transducer arrays to be recognized by means of the possible types of connection, such as the number of pins, provided in the first and/or second part of the plug connectors. As an alternative the several transducer arrays and/or the communication means can transmit different signals when connected to the remaining part of the probe.

**[0048]** In both the cases once the different types have been recognized, the automatic recognition means regulate the processing circuit according to different operational parameters depending on the type of transducer array and/or of the communication means that is connected.

**[0049]** Therefore the present invention relates also to a kit comprising an ultrasound probe, having the operat-

ing and constructional characteristics described above and the characteristics that will be described below, and at least two different removable transducer arrays and/or at least two different removable wireless communication means.

**[0050]** An improvement of the probe of the present invention provides at least a part of the contacts provided at the side of the transducer array and/or at the side of the wireless communication means to be connected to the connector of the board on the opposite face of the frame: this allows communication lines between the electronic circuits of the two boards to be formed such that signals can be transferred from one board to the other one.

**[0051]** Preferably the power generating and storing source provided within the housing space formed by the two boards and by the means supporting them, is a rechargeable battery and it is mounted such that it can be removed from the probe. Even in this case the plug connectors described above are used for connecting the battery to one or both the boards, the contacts of one of the two parts of the plug connector being provided on the battery, while the contacts of the second part are provided on one or both the boards.

**[0052]** Moreover it is necessary to use interface means allowing the probe and/or the battery to be connected to an external power source, which are composed of plug connectors of the type described above, and a recharging electronic circuit. According to a first variant embodiment the recharging electronic circuit is mounted on the boards together with the interface means connecting such circuit to an external power network and allowing the battery to be recharged due to the connection of the battery to the two boards.

**[0053]** As an alternative the recharging electronic circuit is a circuit outside the probe directly connected to the battery through the interface means that allows the battery to be recharged independently of the probe: such variant, in the case the battery is dead, allows the battery to be replaced by a back-up battery without preventing the probe from being used, and the battery from being recharged.

**[0054]** It is also possible to provide the recharging means to be composed of electromagnetic induction recharging means such to allow the battery to be recharged in a wireless mode.

**[0055]** The remote unit to which the ultrasound probe of the present invention transmits the signals through the wireless communication means has communication means therein by means of which it transmits and receives the signals and it has a display device for displaying the video signal resulting from the processing made by the processing unit of the probe.

**[0056]** According to a variant embodiment inside the remote unit there is provided a unit allowing the received signal to further processed, such unit is composed of processor means that execute a logic program processing, transmitting and receiving signals and a storage unit

intended to store the program, the data for executing the program and the data resulting from the execution.

**[0057]** As said above there are provided interface means belonging to the remote unit, which are composed of a user interface allowing the scanning parameters to be manually controlled; such interface communicates with the wireless communication means by sending control signals and/or codes for programming and setting the operational conditions of the processing and generating units of the probe.

**[0058]** An alternative example of the present invention provides the remote unit to have two or more communication channels for transmitting and receiving signals to two or more probes. In this case each probe has to be recognized by the remote unit, such to assign to different channels different probes, thus each probe can be for example univocally identified by an identification code or the probes can have communication channels with a predetermined bandwidth and centered on different frequencies, such to diversify the signals received or transmitted by different probes.

**[0059]** Independently of the number of probes used, the communication, display and further processing means of the remote unit are in common to all the probes, thus it is necessary to provide a method for diversifying the use of such means depending on the probe that is desired to be used. If probe is identified by an identification code, it is necessary for the remote unit to have processing means therein which have comparing tables for relating each probe to its own identification code and which activate one probe or another for the transmission and the reception. As an alternative there are provided switching means that alternately activate the transmission channels of the remote unit relating to frequencies at the bandwidths on which the transmission channels of the different probes are centered.

**[0060]** Advantageously the communication, display and further processing means of the remote unit, are in common to all the probes, since the fact of sharing such means in combination with the storage units provided into the storage unit allows the signals received and transmitted by the different probes to be processed many times, for example, it being possible to alternately or contemporaneously display the different images that then can be compared, modified and/or corrected.

**[0061]** The method applied in the preferred embodiment of the present invention is different from the prior art.

**[0062]** With reference to the prior art such methods provide said transmitting transducer array to send a focused or non-focused ultrasound beam and provide said receiving transducer array to receive the echoes reflected by the structures of the body under examination.

**[0063]** At least a part of the transmitting transducers can be used as receiving transducers and vice versa, alternating transmitting and receiving phases over time.

**[0064]** According to some of the most used operating modes, the focused beam penetrates into the body under examination along lines of sight, that is lines of propaga-

tion that arise at the transmitting transducers and develop into the body under examination following the direction of propagation of the wave front, defining a scan plane or slice.

5 **[0065]** Such lines of sight can be parallel one another or radially arranged depending on the relative geometrical arrangement of the transmitting transducers and of the excitation modes of the transmitting transducers.

10 **[0066]** Similarly the reception by the receiving transducers occurs by means of such lines of sight such that each receiving transducer receives information from the reflected echoes with reference to a sector of the scan plane defined by the line of sight generated by the propagation of the wave generated by a following transmitting transducer or from the transducer used for the transmission.

15 **[0067]** According to a particular method known by the name of compound imaging, several ultrasound beams penetrate into the body under examination according to different points of the transmitting transducer array and the reflected echoes are detected in the reception phase and are transformed into images that later can be combined one another.

20 **[0068]** The drawback of such method is that the frame rate is reduced, such reduction increases as the images generated by different observation points increase.

25 **[0069]** In an alternative embodiment the waves penetrate into the body under examination in a non-focused way or defocused way such that it results in a beam with a wide aperture and the scan slice is largely insonated.

30 **[0070]** In the reception phase each transducer detects a reception signal on which it is necessary to apply windows with specific time shifts depending on the distance of the receiving transducer from the transmitting transducer and from the transmission point in the body under examination in order to gain information concerning the wave reflected by such transmission point in the body under examination.

35 **[0071]** This mode has the drawback that, since the beam is not focused, the introduced acoustic energy is spread into a wider area and therefore each reflection point in the body under examination is impinged by a wave having a lower intensity.

40 **[0072]** This leads necessarily to echoes having a reduced intensity and therefore to an inevitable reduction of the signal to noise ratio in the reception signals.

45 **[0073]** The above drawbacks are overcome by the present invention and in addition to the apparatus the present invention relates also to a method for acquiring ultrasound images according to the general embodiment and/or to the specific embodiment described above.

50 **[0074]** The method of the present invention therefore provides to univocally define a grid of reference points having predetermined positions on the scan plane, by means of which it is possible to precisely define the relative distances between the various points of the scan plane and the transducers.

55 **[0075]** The distance of each point of the grid from each

transducer is known, and, since the propagation velocity of the acoustic wave in the body under examination is known and substantially unchanging, once the space distance is known it is possible to univocally define the time when a wave reflected by any reflection point arranged on the grid impinges on any transducers.

**[0076]** This means that the acoustic wave transmitted from a specific transducer impinges on a reflection point after a predetermined time, it is reflected by such reflection point and returns back in the opposite direction towards the transducer.

**[0077]** The transducer that has transmitted the ultrasound pulse, detects the echoe reflected after a time that is twice the time that the transmitted wave takes to reach the reflection point.

**[0078]** The receiving transducers arranged at the sides of such transducer used both for the transmission and the reception, receive the reflected wave after a time different than the initial transducer, and the time shift is due to the relative arrangement of the transducers and their distance, the distance of each transducer from the reflection point deriving therefrom.

**[0079]** In an example case that provides a linear probe, the receiving transducers that are arranged at the sides of the transmitting transducer receive the reflected signals after a time delay  $\Delta t$  that is directly proportional to the distance between each transducer of such receiving transducers and the transducer that has transmitted the pulse.

**[0080]** Thus it is possible to obtain for each transducer the components of the reception signal containing information coming from the reflection signal of a predetermined reflection point in the body under examination, by applying suitable windows to the reception signal, which are shifted over time according to the appropriate delays.

**[0081]** In theory, due to the fact of having high velocity components, it would be possible to make the calculation of all the points of the image in the time between a transmission and another; in practice it is sufficient to have all the data of each element in the storage and to make the calculation in a time shorter than 1ms.

**[0082]** By combining such components of the reception signals of all or at least of a part of the reception signals, which components of the reception signals each one holds information coming from the reflection signal of the same reflection point in the body under examination, it is possible to generate images with acceptable resolutions, while considerably increasing the frame-rate, since a non-focused transmission is enough for receiving echoes on all or a part of the receiving transducers.

**[0083]** The method of the present invention has the further advantage of providing further transmissions after the first one, and of combining all the obtained images, particularly calculating a mean, in order to obtain a final image that optimizes the contributions of all the images obtained from different transmitting points.

**[0084]** The generation of said grid of points on the scan

plane, that defines lines parallel to the direction of propagation of the acoustic wave that can be parallel each other or diverging depending on the shape of the body section to be displayed, and that can define cells between reflection points of any shape, for example square or rectangular shapes, has the advantage of allowing a high number of images to be combined in a short time, since the distances are known a priori.

**[0085]** By means of this it is also possible to obtain images that can be already overlapped one another, such that a further adjustment and processing are not necessary, thus considerably saving time.

**[0086]** In a preferred embodiment the image frame-rate is more than 1000 frame/sec, but it is possible to combine the obtained images even every 20-30 ms, if the computing power is not sufficient.

**[0087]** According to an embodiment the image is generated along the scan plane or slice of the body under examination by the mean of the reflection signals of the sets of reflection signals generated by the individual spherical transmission pulses transmitted by the several transmitting points.

**[0088]** In a variant embodiment said sum or said mean of the reflection signals of the individual sets of reflection signals is separately calculated for each one of the reflection points, that is the sum or mean is calculated from the values of the reflection signal of each reflection point as stored in the various sets of reflection signals.

**[0089]** According to such embodiment said sum or mean of the reflection signals is calculated upstream of conversion into image data by said processing means.

**[0090]** In an alternative embodiment the reflection signals of the individual sets of reflection signals are converted into image data and then separately stored, for each set of reflection signals, said sum or mean being calculated using the image data deriving from the individual sets of reflection signals.

**[0091]** According to a further embodiment the determination of a sub-grid smaller than said grid is provided, whose peripheral points coincide with at least part of the points of said grid and that is formed of as many points as those contained in said grid, in the area delimited by the peripheral points of said sub-grid or more.

**[0092]** This guarantees the possibility of defining a region of interest into an obtained image, thus allowing the following acquisitions to be made in such region of interest.

**[0093]** This is possible by defining said sub-grid, with the relevant recalculation of the points constituting it.

**[0094]** In a preferred embodiment the number of points in the sub-grid is the same as the points of the grid, since it is optimized for the computing power of the processing means.

**[0095]** In an alternative embodiment the transmitting transducers and the receiving transducers used for scanning are provided in a number smaller than the total amount and are limited to a reduced area surrounding or near the region of interest wherein said sub-grid is de-

fined.

**[0096]** As it is known to the person skilled in the art, the transmitting transducers can also be the receiving transducers they being actuated alternately for the transmission and reception of acoustic signals.

**[0097]** In a further embodiment the processing means comprise means for forming and focusing an acoustic beam on the individual reflection points the so called receive/transmit beamformers.

**[0098]** In a further embodiment the array of transmitting and receiving transducers is a two-dimensional array, said array of transducers generating scan volumes for the body under examination where acoustic pulses are transmitted and from where the reflection pulses of the transmitted acoustic pulses are received.

**[0099]** In this case the predetermined reflection points are arranged in a three-dimensional grid within the scan volume, the transmitting points are arranged along the two-dimensional surface of the array of transmitting transducers and each set of reflection signals comprises the reflection signals of the reflection points of the three-dimensional grid of the reflection points for forming a three-dimensional image.

**[0100]** The invention relates also to other characteristics further improving the above apparatus and method and that are object of the subclaims.

**[0101]** These and other characteristics and advantages of the present invention will be more clear from the following description of some embodiments shown in the annexed drawings wherein:

Fig.1 is a schematic diagram of the various components of an apparatus according to the invention where image scanning and forming means are integrated in a typical ultrasound probe;

Fig. 2 is a view of the apparatus of the present invention, with a particular reference to the upper board;

Fig.3 is a view of the apparatus of the present invention, with a particular reference to the lower board;

Fig.4 is the arrangement of the boards and the connection of said boards with the array of transducers and with the wireless communication means;

Fig.5 is a view of the apparatus of the present invention, with a particular reference to the battery and the frame supporting the two boards;

Fig.6 is the means supporting the boards;

Fig. 7 is the kit of the present invention.

Figs. 8, 9 and 10 are schematic and simplified views of the transmission of ultrasound pulses by different transmitting points;

Figs. 11, 12 and 13 are schematic and simplified views of the reflection of said ultrasound pulses by different reflection points on the grid;

Fig. 14 is a schematic and simplified view of the storage of the signal components concerning the individual reflection points into individual storage cells;

Fig.15 is a schematic and simplified view of the de-

termination in a reception signal of a transducer of the components concerning every individual reflection point on the grid and their storage into corresponding storage cells;

Fig. 16 is a schematic and simplified view of the storage in storage cells of the values corresponding to the reflection signals of each point on the grid;

Fig.17 is the determination of a sub-grid for the detailed analysis of a limited area in the body under examination.

**[0102]** With reference to the figures 1 to 6, the figures show an apparatus according to the invention having the shape, dimensions and weight typical of currently known ultrasound probes. Therefore in the following description the term probe is to be understood as a synonym for the term apparatus for ultrasound image acquisition unless a different meaning is specifically given with reference to a specific context. According to a possible variant embodiment, the shown ultrasound probe is composed of an outer casing 1 comprising two narrow and longer side faces and two wider and longer faces, parallel to each other and oriented lengthwise in the direction of a longitudinal axis along the direction of propagation of the acoustic beam transmitted from the probe. Moreover there are provided two boards 11 and 12, which are parallel or substantially parallel to the wider faces, the units generating and processing the transmitted and/or received signals, as well as the circuits powering the units are arranged on such boards 11 and 12.

**[0103]** The array of electroacoustic transducers 3 is fastened at one of the two ends of the boards 11 and 12, each one of which transducers transmits ultrasound waves when powered with an electric excitation signal and moreover it generates an electric reception signal when impinged by an ultrasound wave or pulse that can be generated by the reflection of ultrasound waves transmitted from the same transducer.

**[0104]** Advantageously, but not exclusively, the array of transducers 3, at the side composed of the ultrasound transmitting surfaces 32, is covered with at least one matching layer, intended to match the acoustic impedance of the array of transducers 3 to that of the body to be examined, in order to avoid abrupt changes in the acoustic impedance, that would produce such reflection surfaces to prevent the ultrasound beam from penetrating into the body under examination.

**[0105]** The array of electroacoustic transducers 3 is connected to the boards 11 and 12 by means of plug connectors 111, a first part of which cooperating with a corresponding second part, in the figure they being oriented with the connection contacts in the longitudinal direction with respect to the probe such to be coupled and uncoupled by a movement in such direction.

**[0106]** The contacts of the first part of the plug connector 111 are fastened to inputs and/or outputs respectively of the array of transducers 3 and the contacts of the second part are at the ends of the two boards 11 and 12,

such that the transducer array 3 is connected with the means generating 112 and processing 113 the transmitted and/or received signals, a storage area 213 being associated thereto whose task will be described below with reference to particular image scanning and forming modes of the preferred embodiment.

**[0107]** The variant embodiment with a particular reference to figures 1 to 6 provides the use of mechanical engagement means 13 intended to fasten the transducer array 3 to the probe casing.

**[0108]** The generating unit 112 generates excitation signals that are transmitted, through the plug connectors 111, to the transducer array 3 and it comprises means generating the excitation signals and means feeding the signals to the individual transducers.

**[0109]** According to a variant embodiment the generating unit 112 sends time-varying frequency excitation signals, the transmitted ultrasound pulses being encoded by frequency variations over time according to a specific function over time such as for example a linear or non-linear function. Particularly so called "CHIRP" signals are generated, whose frequency variation over time allows the number of communication lines between the transducer array and the signal generating unit 112 and processing unit 113 to be drastically reduced.

**[0110]** To this end, each transducer, of the transducer array 3, is connected to the processing unit 113 and to the generating unit 112 by a switch 117, which has two conditions, an operating condition, enabling each transducer to receive/transmit electric excitation signals, and a non-operating condition, disabling each transducer from receiving/transmitting electric excitation signals, respectively. The transition from the operating condition to the non-operating condition is set by the processing unit 113 that alternates the reception/transmission of each individual transducer according to specific time sequences different for each individual transducer of the transducer array 3.

**[0111]** Each transducer of the transducer array 3 generates a reception signal that is transmitted to the processing unit 113 through the plug connectors 111.

**[0112]** The unit 113 further comprises means for converting the reception signals into image data, as well as video signal generating means: the reception signal processed by the processing unit 113 as an output from the unit itself is therefore converted into a video signal.

**[0113]** With a particular reference to figures 1 to 6, the processing unit 113 is composed of a FPGA device (Field Programmable Gate Array) provided in combination with an analog/digital converter 114, that converts the input signals of the FPGA device into digital data such that they can be processed by said device and in combination with a storage or a plurality of storages generally denoted by 213 and whose tasks will be described below in more detail.

**[0114]** The video signal as the output from the processing unit 113 is sent to the wireless communication means 4 that allow video signals to be transmitted and allow the

ultrasound probe according to the present invention to communicate with a remote display, storage and further processing unit not shown in the figure.

**[0115]** Such communication means are connected to the other end of the boards 11 and 12 by plug connectors 116, a first part of which cooperating with a corresponding second part, they are connected one another in an engaging disengaging direction perpendicular to the direction of propagation of the beam and perpendicular to the surface of the boards 11 and 12, such that the boards 11 and 12 are mounted in connection with the wireless communication means 4.

**[0116]** The contacts of the first part of the plug connector 116 are fastened to the inputs and/or outputs respectively of the communication means 4 and the contacts of the second part are at the ends of the two boards 11 and 12, such that the wireless communication means 4 are in connection with the means 112 generating and with the means 113 processing the transmitted and/or received signals.

**[0117]** Moreover in the embodiment shown in the figures 1 to 6, the ultrasound probe of the present invention provides the use of means for powering electronic circuits which are composed of a power generating and storing source, as a battery or the like 5, provided in combination with and connected to circuits matching and connecting the battery to the processing and generating units 113 and 112, and to the wireless communication means 4.

**[0118]** In an alternative embodiment of the apparatus according to the present invention at least a part of the contacts provided at the side of the transducer array 3 and/or at the side of the wireless communication means 4 is connected to the connector of the board on the opposite face of the frame 6: this allows communication lines among the electronic circuits of the two boards 11 and 12 to be formed such that signals can be transferred from one board to the other one.

**[0119]** The battery 5 is arranged in a housing space 51 that is composed of a frame supporting the two boards 11 and 12.

**[0120]** The boards 11 and 12 are supported by supporting means 61 and 62, that allow the boards 11 and 12 to be arranged parallel each other, and allow also a housing space 51 for the battery 5 to be made: the supporting frame 6, composed of the supporting means 61 and 62, spaces apart the boards 11 and 12 and allows the battery 5 to be housed within the space between the two boards. In the figure, the frame 6 is composed of a peripheral rim having a thickness substantially corresponding to the thickness of the battery 5 and/or to the gap between the two boards 11 and 12, such rim delimits a central space 51 between the two boards 11 and 12 for housing the battery 5: it is possible to provide a plate, not shown in the figure, closing at least one of the open sides of the frame 6 that allows the frame 6 to rest on said plate such to form the bottom of the housing space 51 comprising the contacts for the connection between the battery 5 and the boards 11 and 12 such to power

the generating unit 112 and the processing unit 113.

**[0121]** Preferably the power means and the generating unit 112 and the processing unit 113 are made in the form of printed electronic circuits on the two boards 11 and 12, which are fastened to the frame 6, which are oriented parallel to the larger faces of the probe casing.

**[0122]** Advantageously the battery 5, provided inside the housing space 51 composed of the two boards 11 and 12 and of the supporting means 61 and 62 thereof, is a rechargeable battery and it is mounted so as it can be removed from the probe. Even in this case the plug connectors 111 and 116 described above are used for connecting the battery 5 to one or both the boards 11 and 12, the contacts of one of the two parts of the plug connector will be on the battery 5, while the contacts of the second part will be on one or both the boards 11 and 12.

**[0123]** Moreover it is necessary to use interface means allowing the probe and/or the battery 5 to be connected to an external power source, which are composed of plug connectors of the type described above, and a recharging electronic circuit. According to a first variant embodiment the recharging electronic circuit is fitted on the boards 11 and 12 together with the interface means that connect such circuit to an external power network and allow the battery 5 to be recharged by means of the connection of the battery 5 to the two boards 11 and 12.

**[0124]** As an alternative the recharging electronic circuit is a circuit outside the probe directly connected to the battery 5 by the interface means allowing the battery 5 to be recharged independently of the probe: if the battery 5 is dead such variant allows the battery to be replaced by a back-up battery without preventing the probe from being used and the battery from being recharged.

**[0125]** It is also possible to provide the recharging means to be composed of electromagnetic induction recharging means such to allow the battery 5 to be recharged in the wireless mode.

**[0126]** Figure 7 shows the kit of the present invention comprising an ultrasound probe, having the constructional and operational characteristics described above, and at least two different removable transducer arrays 3 and/or at least two different removable wireless communication means 4.

**[0127]** Such figure shows also a variant embodiment of the present invention providing the transducer array 3 and the wireless communication means 4 to be removably mounted to the structure of the probe 1, such that different transducer arrays and different communication means can be used while keeping the same control electronics.

**[0128]** It is possible to mount and remove the transducer array 3 and the communication means 4 by means of the plug connectors already described above, which are made as electric/mechanical connection means composed in turn of a first part of a plug connector cooperating with a corresponding second part of a plug connector 111, 116 with the first part fastened to the inputs/outputs

of the transducer array 3 and to the input/outputs of the wireless communication means 4 respectively and with the second part fastened to the ends of the casing of the probe 1, holding the control electronics.

**[0129]** Within such control electronics there are provided means, not shown in the figure, for automatically recognizing which type of transducer array 3 and which type of wireless communication means 4 are used.

**[0130]** Such recognition means can be composed of a logic execution program loaded within the processing unit 113 and for instance they can allow the different transducer arrays 3 to be recognized by means of the possible types of connection, such as the number of pins 31, 41 provided in the first and/or second part of the plug connectors. As an alternative the different transducer arrays 3 and the communication means 4 can transmit different signals when connected to the remaining part of the probe.

**[0131]** In both the cases, once the different types have been recognized, the automatic recognition means regulate the processing circuit 113 according to operating parameters that are different depending on the type of transducer array 3 and/or of the communication means 4 that are connected.

**[0132]** Finally it has to be noted that the probe described above can be associated to any type of device intended to generate a synergy from a functional point of view with the probe. An example could be represented by means automatically recognizing the users, such as a fingerprint scanner, that allow, through the use of databases, the user to be automatically recognized and the type of examinations that such user can perform to be verified by automatically setting specific operating parameters of the probe and of the remote display unit.

**[0133]** The figures 8, 9 and 10 and the following ones show in more detail the structure and the operating modes of the processing means with a particular reference to means generating the excitation signals, to means activating the transducers for the reception, and to the mode for forming the image starting from received data. In the figures 8, 9 and 10 there is shown a transducer array 3, said array comprising the transducers  $T_1, T_2 \dots T_n$ , arranged according to a system of cartesian axes 1 and p, where 1 is the width of the transducer array 3 and p is the depth into the body under examination.

**[0134]** At least a part of the transmitting transducers can be used as receiving transducers and vice versa, by alternating the transmission and reception phases over time.

**[0135]** In the preferred embodiment shown in the figures the transducer array 3 is used both for the transmission and the reception.

**[0136]** A set of predetermined reflection points  $P_{1,1} \dots P_{n,n}$  is defined which are arranged at a predetermined distance from each other and forming a grid 300 extending in the scan plane or slice along which the body under examination is imaged.

**[0137]** Such grid can define cells having any shape,

for example square or rectangular shapes, between reflection points.

**[0138]** The individual transducers successively transmit an ultrasound transmission pulse in the form of a spherical wave from each of a plurality of transmitting points all along the extension of the array of transmitting transducers towards the body under examination defining a scan plane or slice, where anatomical structures of interest 300, 310 are provided.

**[0139]** Such successive transmission of an acoustic pulse in one preferred embodiment occurs by each transducer  $T_1, \dots, T_n$  of the transducer array 1, such as shown in the figures 8, 9 and 10, wherein figure 8 shows a first transmission of the acoustic pulse by the transducer  $T_1$  placed at a first end of the transducer array 3, figure 9 shows a second transmission by the transducer  $T_2$  immediately following the transducer  $T_1$  and figure 10 shows a last transmission by the transducer  $T_n$  arranged at a second end of the transducer array 3, such to show that each transducer in the array of transducers 3 has made a transmission, such transmissions being made successively starting from said first end of the transducer array 1 to said second end.

**[0140]** It is possible to provide further embodiments where only a part of the transducers performs an transmission, for example a transducer every two or three transducers or according to any different arrangement.

**[0141]** In particular for example when the object to be examined is small with respect to the aperture of the transducer array it is possible to provide the transmission only by one subset of transducers of the array which subset has a number of transducers smaller than the total number of transducers that are arranged directly adjacent one another at least the first and/or the last transducer of the subset non coinciding with the first or the last transducer of the array respectively with reference to their arrangement in the transducer array.

**[0142]** It is possible to provide also two or more subsets of transducers of the transducer array. In this case each subset can comprise a certain number of transducers different from one subset to another which are arranged in a direct adjacent relation or which are alternated to inoperative transducers or to transducers of another subset.

**[0143]** When for example the Field of View (FOV) of the probe include different objects that are spaced apart and that have dimensions smaller than said FOV it is possible to provide two subsets of transducers each one intended to acquire an image relating to one of the different objects and therefore it comprises different transducers of the transducer array having a different position within the array.

**[0144]** The person skilled in the art can easily understand how any other combination of the transducers can be provided in order to transmit the transmission pulses depending on needs.

**[0145]** The transmitted acoustic pulses are reflected by the structural elements of the body under examination

having acoustic reflector features and are received by said transducer array 3, such that each transducer generates a reception signal.

**[0146]** There are also provided processing means 113 to which each transducer is connected and each transducer provides to such processing means 113 the electric reception signal generated by the excitation of said transducer upon reception of the reflected acoustic signal impinging upon said receiving transducer.

**[0147]** Each point of the grid 300 therefore generates a reflection signal corresponding to the structural features of a location in the body under examination that is situated precisely in that point.

**[0148]** This can be clearly seen in figures 11, 12 and 13, where reflection acoustic pulses generated by three different points of the grid 200 are schematically shown by way of example:  $P_{2,2}$ ,  $P_{19,2}$  and  $P_{10,13}$ . Obviously what is schematically shown for said three points is valid for each point of the grid of the reflection points.

**[0149]** The distance of each reflection point from each transducer is denoted by the arrows, such distance corresponding to the time covered by the acoustic wave and therefore to the time shift of the signal components concerning the same point in the reception signal of each transducer.

**[0150]** The distance of each point of the grid from each transducer is known, and, since the propagation velocity of the acoustic wave in the body under examination is known and substantially unchanging, once the space distance is known it is possible to univocally define the time when a wave reflected by any reflection point arranged on the grid impinges on any transducers  $T_1 \dots T_n$ .

**[0151]** This means that the acoustic wave transmitted from a specific transducer impinges on a reflection point after a predetermined time, it is reflected by such reflection point and returns back in the opposite direction towards the transducer.

**[0152]** Take figure 11 as an example and let the condition be after the transmission by the transducer  $T_2$  shown in figure 9: the acoustic pulse is reflected by the point  $P_{2,2}$  and it returns back towards the transducer array 3.

**[0153]** The transducer  $T_2$  that has transmitted the ultrasonic pulse, detects the echoe reflected by the point  $P_{2,2}$  after a time that is twice the time that the transmitted wave takes to reach the reflection point and that corresponds to the distance denoted by the arrow 120.

**[0154]** The receiving transducers  $T_1$  and  $T_3$ , arranged at the sides of the transducer  $T_2$ , receive the reflected wave after a time different than the transducer  $T_2$ , and the time shift is due to the relative arrangement of the transducers  $T_1 \dots T_n$  and to their distance, the distance of each transducer from the reflection point deriving therefrom.

**[0155]** Particularly the distances of  $T_1$  and  $T_3$  with respect to the point  $P_{2,2}$  are shown by arrows 110 and 130 respectively, and the further distances of the further transducers are shown by the further arrows, such that

the transducers arranged at the sides of the transmitting transducer receive the reflected signals after a time delay  $\Delta t$  that is directly proportional to the distance between each one of such receiving transducers and the transducer transmitting the pulse.

**[0156]** In the situation shown in figure 12 the reflection point considered is  $P_{19,2}$  and even in this case the distances between the point  $P_{19,2}$  and the transducers, shown by arrows, increase as we move away from the transducer  $T_2$ , such that the component of the reception signal of each transducer concerning the reflection signal of the point  $P_{19,2}$  will be found by applying a time delay  $\Delta t$  corresponding to such distances when reading such signal by means of said processing means 113.

**[0157]** Thus it is possible to find for each transducer the components of the reception signal that contain information coming from the reflection signal of a predetermined reflection point in the body under examination coinciding with a predetermined point of the grid, by applying appropriate windows to the reception signal, shifted over time according to the appropriate delays.

**[0158]** As regards figures 11 and 12 the component of the reflected signal obviously will have the maximum delay when reaching the transducer  $T_n$ , while in figure 13, where the reflection point considered is the point  $P_{10,13}$  the reflection components of such point will have a smaller delay in the intermediate region of the transducer array 3 and higher delays at the ends of the transducer array 1.

**[0159]** Figure 14 schematically shows the storage of the signal components concerning the individual reflection points in individual storage cells 50 provided in the storage area 213 described with reference to the previous figures.

**[0160]** Said storage is made by said processing means 113 which receive the individual reception signals from the transducer array 1 and combine them by applying said time delays such that the components in each reception signal concerning each reflection signal and consequently each reflection point are summed together.

**[0161]** Such values are stored into said cells 50, thus obtaining a set of reflection signals that corresponds to the components of the reflected signal concerning each point on the grid 200.

**[0162]** This means that there is a one-to-one correspondance between the reflection features of a point of the body under examination corresponding to a point of the grid, for example  $P_{2,1}$  and the value stored within the relevant storage cell, in this case  $50_{2,1}$ .

**[0163]** Figure 15 schematically shows the determination into a reception signal of one transducer of the components relevant to each individual reflection point on the grid after a single transmission and their storage into corresponding storage cells.

**[0164]** In order to do that said means 113 processing the reception signals combine together said reception signals provided by the individual transducers  $T_1 \dots T_n$ .

**[0165]** Such combination occurs with said relative time shifts of the reception signals of the individual transduc-

ers  $T_1 \dots T_n$ , which shifts are such that the individual components of the reception signals of the individual transducers  $T_1 \dots T_n$  are combined together, which components correspond to the component of the reflected signal generated by the reflection of the transmission pulse by a predetermined reflector of the structure of the body under examination, which is in a predetermined position with respect to the array of transducers 1.

**[0166]** The time shift of the reception signals for defining the reflection signal of the transmission pulse by each one of said predetermined reflection points is defined beforehand according to the predetermined relative distances between the individual reflection points.

**[0167]** Thus the determination of the reflection signal occurs by combining the components of the reception signals of the individual receiving transducers which components fall within time intervals of the reception signals having said delays and which components derive from the corresponding components of the reflection signal determined by each of said predetermined reflection points.

**[0168]** This can be clearly seen in figure 15, where, after a single transmission of an acoustic transmitting pulse in the form of a spherical wave by a single transducer, the transducer  $T_1$  receives a reception signal 610 which is analysed by said processing means 113.

**[0169]** The processing means 113 define, by means of time windows 410 arranged according to the predetermined delays corresponding to the predetermined distances of the points on the grid 200 from the transducer  $T_1$ , the components of the reception signal concerning the reflection signal of each point on the grid, which are stored within the corresponding storage cells 50.

**[0170]** The same procedure occurs for each transducer  $T_1 \dots T_n$ , such as shown in figure 16, where, by decomposing each reception signal 610, 620 etc. of each transducer it is possible to define the set of reflection signals.

**[0171]** Such determination of the set of reflection signals by the individual reflection points of said grid of predetermined reflection points is therefore carried out for each spherical transmission pulse transmitted by a different transmitting point and said sets of reflection signals for each one of the spherical transmission pulse transmitted by the individual transmitting points are separately stored.

**[0172]** To this end it is possible to provide further arrays of storage cells 50, each one intended to store the different sets of reflection signals, each one concerning a single transmission.

**[0173]** In a preferred embodiment said storage cells are virtual storage addresses on a single physical storage unit, a program managing such storage unit being provided.

**[0174]** Starting from the sets of the stored reflection signals said processing means 113 generate the image along the scan plane or slice of the body under examination by summing the reflection signals of the sets of reflection signals generated by the individual spherical

transmission pulses transmitted by the various transmitting points.

**[0175]** According to a further embodiment the image is generated along the scan plane or slice of the body under examination by the mean of the reflection signals of the sets of reflection signals generated by the individual spherical transmission pulses transmitted by the various transmitting points.

**[0176]** In a variant embodiment said sum or said mean of the reflection signals of the individual sets of reflection signals is separately calculated for each of the reflection points, that is the sum or mean is calculated from the values of the reflection signal of each reflection point as stored in the various sets of reflection signals.

**[0177]** According to such embodiment said sum or mean of the reflection signals is calculated upstream of conversion into image data by said processing means 114.

**[0178]** In an alternative embodiment the reflection signals of the individual sets of reflection signals are converted into image data and then separately stored, for each set of reflection signals, said sum or mean being calculated using the image data deriving from the individual sets of reflection signals.

**[0179]** Figure 15 shows the determination of a sub-grid 210 smaller than said grid 200, whose peripheral points coincide with at least part of the points of said grid and that is formed of as many points as those contained in said grid 200, in the area delimited by the peripheral points of said sub-grid 210 or more.

**[0180]** In the example of figure 17 therefore a region of interest is defined corresponding to a particular structure of interest 310 into an obtained image, thus allowing the following acquisitions to be made in such region of interest.

**[0181]** Said processing means 113 are intended for determining said sub-grid 210 and for the relative recalculation of the points constituting it.

**[0182]** In a preferred embodiment the number of points in the sub-grid 210 is the same of the points of the grid 200, since it is defined by the number of transducers  $T_1 \dots T_n$  and by the computing power of the processing means 113.

**[0183]** In an alternative embodiment the transducers used for scanning are provided in an amount smaller than the total amount and are limited to a reduced area surrounding or near the region of interest wherein said sub-grid 210 is defined.

**[0184]** According to a further embodiment there is provided a user interface for displaying the image or video so obtained and for setting the perimeter of the sub-grid 210, a computational algorithm being provided for automatically defining the internal points of said sub-grid 210.

**[0185]** In a further embodiment the processing means 113 comprise means for forming and focusing an acoustic beam on the individual reflection points the so called receive/transmit beamformers.

**[0186]** In a further embodiment the array of transduc-

ers  $T_1 \dots T_n$  is a two-dimensional array, said array of transducers generating scan volumes for the body under examination, in which acoustic pulses are transmitted and from which reflection pulses of the transmitted acoustic pulses are received.

**[0187]** In this case the predetermined reflection points are arranged in a three-dimensional grid 200 within the scan volume, the transmitting points are arranged along the two-dimensional surface of the array of transmitting transducers and each set of reflection signals comprises the reflection signals of the reflection points of the three-dimensional grid 200 of reflection points for forming a three-dimensional image.

**[0188]** The technique shown with reference to the two-dimensional embodiments can be easily extended also to three-dimensional image acquisition modes. In this case the probe is of the matrix array type and therefore the array of transducers is a two-dimensional array and the grid can be defined with a three-dimensional shape since all the concepts described above for a two-dimensional grid can be extended without any need of making inventive modifications to the three-dimensional grid and therefore to 3D ultrasound imaging.

## Claims

- Method for ultrasound image acquisition, which method provides
  - the transmission of ultrasonic pulses towards a body under examination; which pulses are generated by transmitting transducers ( $T_1 \dots T_n$ ) which are grouped into an array of transmitting transducers (3);
  - which transmitting transducers ( $T_1 \dots T_n$ ) are each connected to an electric excitation pulse generator and transform said electric pulses into acoustic pulses;
  - the reception of the reflection acoustic pulses generated upon reflection of the transmission pulses by the structural elements of the body under examination having acoustic reflector features by receiving transducers ( $T_1 \dots T_n$ );
  - which receiving transducers ( $T_1 \dots T_n$ ) are grouped into an array of said receiving transducers (3);
  - and which receiving transducers ( $T_1 \dots T_n$ ) are each connected to reception signal processing means (113);
  - each receiving transducer ( $T_1 \dots T_n$ ) providing to said reception signal processing means (113) the electric reception signal generated by the excitation of said transducer ( $T_1 \dots T_n$ ) upon reception of the reflection acoustic signal impinging upon said receiving transducer ( $T_1 \dots T_n$ );
  - the reception signals provided by the individual receiving transducers ( $T_1 \dots T_n$ ) being combined by said reception signal processing means (113) and said combination occurring with relative time shifts

of the reception signals of the individual receiving transducers ( $T_1 \dots T_n$ ) which shifts are such that the individual components of the reception signals of the individual receiving transducers ( $T_1 \dots T_n$ ) are combined together, which components correspond to the component of the reflection signal generated by the reflection of the transmission pulse by a predetermined reflector of the structure of the body under examination which is in a predetermined position with respect to the array of receiving transducers (3); and said step combining the reception signals of the individual receiving transducers ( $T_1 \dots T_n$ ) being repeated with different time shifts, to obtain a combination of the components of the reception signals caused by the reflection of the transmission signal by each of the reflectors of the structure of the body under examination in a predetermined scan plane or a predetermined slice of the body under examination, which scan plane or which slice are parallel to the direction of propagation of the transmission pulse and the reflection signals

**characterized in that**

the method provides the following steps:

defining a set of predetermined reflection points ( $P_{1,1} \dots P_{n,n}$ ) arranged at a predetermined distance from each other and forming a grid (200) of predetermined reflection points which extends in the scan plane or slice along which the body under examination is imaged;  
the time shift of the reception signals for determining the transmission pulse reflection signal from each of said predetermined reflection points ( $P_{1,1} \dots P_{n,n}$ ) being defined beforehand according to the predetermined relative distances between the individual reflection points ( $P_{1,1} \dots P_{n,n}$ ), which determination of the reflection signal occurs by combining the components of the reception signals of the individual receiving transducers ( $T_1 \dots T_n$ ) which components fall within time intervals of the reception signals having said delays and which components derive from the corresponding components of the reflection signal determined by each of said predetermined reflection points ( $P_{1,1} \dots P_{n,n}$ );  
successively transmitting an acoustic transmission pulse in the form of a spherical wave from each of a plurality of transmitting points all along the array of transmitting transducers (3);  
determining the set of reflection signals from the individual reflection points of said grid (200) of predetermined reflection points ( $P_{1,1} \dots P_{n,n}$ ) for each spherical transmission pulse transmitted by a different transmission point and separately storing said sets of reflection signals for each of the spherical transmission pulses transmitted by the individual transmitting points;  
generating the image along the scan plane or

slice of the body under examination by summing the reflection signals of the sets of reflection signals generated by the individual spherical transmission pulses transmitted by the various transmitting points; encoding the set of pixels or voxels of said image so obtained as a video signal and transmitting the video signal by a wireless mode to a remote reproducing/display unit.

2. Method for ultrasound image acquisition, according to claim 1, wherein the image is generated along the scan plane or slice of the body under examination by the mean of the reflection signals of the sets of reflection signals generated by the spherical transmission pulses transmitted by the various transmitting points.
3. Method for ultrasound image acquisition, according to one or more of the preceding claim 1 or 2, wherein said sum or said mean of the reflection signals of the individual sets of reflection signals is separately calculated for each of the reflection points ( $P_{1,1} \dots P_{n,n}$ ), otherwise the sum or mean is calculated from the values of the reflection signal of each reflection point ( $P_{1,1} \dots P_{n,n}$ ) as stored in the various sets of reflection signals.
4. Method for ultrasound image acquisition, according to one or more of the preceding claims 1 to 3, wherein said sum or mean of the reflection signals is calculated upstream from the conversion into image data by said processing means (113).
5. Method for ultrasound image acquisition, according to one or more of the preceding claims 1 to 4, wherein the reflection signals of the individual sets of reflection signals are converted into image data and then separately stored, for each set of reflection signals, said sum or mean being calculated using the image data derived from the individual sets of reflection signals.
6. Method for ultrasound image acquisition, according to one or more of the preceding claims 1 to 5, wherein a sub-grid (210) smaller than said grid (200) is determined, whose peripheral points coincide with at least part of the points of said grid (200).
7. Method for ultrasound image acquisition, according to claim 6, wherein said sub-grid (210) is composed of as many points as those contained in said grid (200), in the area delimited by the peripheral points of said sub-grid (210) or more.
8. Method for ultrasound image acquisition, according to one or more of the preceding claims 1 to 7, wherein the transmitting transducers ( $T_1 \dots T_n$ ) also act as receiving transducers ( $T_1 \dots T_n$ ) the latter being al-

ternately actuated for transmission and reception of acoustic signals.

9. Method for ultrasound image acquisition, according to one or more of the preceding claims 1 to 8, wherein the processing means (113) include means for forming and focusing an acoustic beam on the individual reflection points ( $P_{1,1} \dots P_{n,n}$ ), known as receive/transmit beamformers. 5
10. Method for ultrasound image acquisition, according to one or more of the preceding claims 1 to 9, wherein the array of transmitting and receiving transducers (3) is a two-dimensional array, said array of transducers (3) generating scan volumes of the body under examination, in which acoustic pulses are transmitted and from which reflection pulses of the transmitted acoustic pulses are received, the predetermined reflection points ( $P_{1,1} \dots P_{n,n}$ ) being arranged in a three-dimensional grid (200) within the scan volume, 10  
and the transmitting points being arranged along the two-dimensional surface of the array of transmitting transducers (3), 15  
each set of reflection signals comprising the reflection signals of the reflection points of the three-dimensional grid (200) of reflection points ( $P_{1,1} \dots P_{n,n}$ ) for forming a three-dimensional image. 20
11. Method according to one or more of the preceding claims 1 to 10, **characterized in that** the individual acoustic pulses are transmitted by one or more subsets of transducers of the array, each of which subsets has a smaller number of transducers than the total number of transducers of the array of transducers. 25
12. Method according to claim 11, **characterized in that**, in at least one subset of transducers, at least the first and/or the last transducer of the subset are not coincident with the first or the last of the transducers of the array respectively, with reference to their arrangement in the array of transducers. 30
13. Method according to claim 11 or 12, **characterized in that** the transducers of at least one subset are alternated with inoperative transducers or transducers of another subset, or are in direct adjacent relation. 35
14. Apparatus for ultrasound image acquisition integrated into the casing of an ultrasound probe for ultrasound imaging apparatuses which probe comprises: 40  
an array of electroacoustic transducers (3), each one of which transmitting ultrasound waves when powered with an electric excitation signal and generating an electric reception signal when 45

impinged by an ultrasound wave or pulse generated for example by the reflection of ultrasound waves transmitted therefrom; 5  
said array of electroacoustic transducers (3) being provided with at least a communication line to a processing unit (112) through which each transducer of said array of transducers (3) feeds reception signals to a processing unit (113), and with a communication line through which the electric excitation signals generated by a generating unit (112) are fed to each transducer of said array of transducers (3) for exciting the transducer to transmit ultrasound waves; 10  
said generating unit (112) comprising excitation signal generating means and means for feeding said signals to said array of transducers (3), wherein at least said processing unit (113) is fitted into the probe casing and comprises converting means for converting reception signals into an image, as well as video signal generating means for generating an image on a display unit, wireless communication means (4) being provided for the transmission between said probe and a remote unit displaying, storing said images as video signals, 15

**characterized in that**

the processing means comprise a storage wherein sequences of time windows for exciting the individual transducers to transmit ultrasound pulses are stored, which windows are defined such to cause an acoustic transmission pulse to be successively transmitted in the form of a spherical wave from each of a plurality of transmitting points arranged all along the array of transmitting transducers (3) and wherein sequences of time windows for the reception of reflection pulses of the transmitted pulses are stored, which reflection pulses are converted into reception signals by each transducer during the corresponding reception time window of said transducer and which reception time windows are calculated beforehand for each point of a set of predetermined reflection points ( $P_{1,1} \dots P_{n,n}$ ) arranged at a predetermined distance one from the other and forming a grid (200) of predetermined reflection points extending in the scan plane or slice along which the body under examination is imaged, such that by the successive transmission of an acoustic transmission pulse in the form of a spherical wave from each of a plurality of transmitting points arranged all along the array of transmitting transducers (3) the set of reflection signals is defined from the individual reflection points ( $P_{1,1} \dots P_{n,n}$ ) of said grid (200) of predetermined reflection points for each spherical transmission pulse transmitted by a different transmission point, 20  
or said converting means calculate, in real time 25

and every time, said time windows and

said converting means comprise an image forming storage wherein said sets of reflection signals for each of the spherical transmission pulses transmitted by the individual transmitting points are stored by means of said storage means and the image along the scan plane or slice of the body under examination is generated by summing the reflection signals of the sets of reflection signals generated by the individual spherical transmission pulses transmitted by the various transmitting points.

## Patentansprüche

1. Verfahren zur Ultraschallbilderfassung, welches Verfahren die Übertragung von Ultraschallimpulsen in Richtung eines zu untersuchenden Körpers vorsieht; welche Impulse durch Sendewandler erzeugt werden (T1 ... Tn) die zu einer Anordnung von Sendewandlern (3) gruppiert sind; welche Sendewandler (T1... Tn) jeweils mit einem elektrischen Erregerimpulsgenerator verbunden sind und diese elektrische Impulse in akustische Impulse umwandeln; der Empfang der bei Reflexion der Sendeimpulse durch die Strukturelemente des zu untersuchenden Körpers erzeugten Reflexionsschallimpulse mit akustischen Reflektormerkmalen durch Empfangswandler (T1... Tn); welche Empfangswandler (T1... Tn) zu einer Anordnung von Empfangswandlern (3) gruppiert sind; und welche Empfangswandler (T1... Tn) jeweils mit Empfangssignalverarbeitungsmitteln (113) verbunden sind; jeder Empfangswandler (T1... Tn) den Empfangssignalverarbeitungsmitteln (113) das durch die Anregung des Wandlers (T1...Tn) erzeugte elektrische Empfangssignal zur Verfügung stellt, nach dem Empfang des auf den Empfangswandler (T1...Tn) auftreffenden Reflexionsschallsignals ; die von den einzelnen Empfangswandlern (T1...Tn) bereitgestellten Empfangssignale von den Empfangssignalverarbeitungsmitteln (113) kombiniert werden und die Kombination mit relativen Zeitverschiebungen der Empfangssignale der einzelnen Empfangswandler (T1...Tn) erfolgt, welche Verschiebungen derart gestaltet sind, dass die einzelnen Komponenten der Empfangssignale der einzelnen Empfangswandler (T1... Tn) zusammengefasst sind, welche Komponenten der durch die Reflexion des Sendeimpulses durch einen vorbestimmten Reflektor der Struktur des zu untersuchenden Körpers erzeugten Komponente des Reflexionssignals entsprechen, wobei der zu untersuchende Körper sich in einer vorbestimmten Position in Bezug auf die An-

ordnung von Empfangswandlern (3) befindet; und wobei der Schritt des Kombinierens der Empfangssignale der einzelnen Empfangswandler (T1... Tn) mit unterschiedlichen Zeitverschiebungen wiederholt wird, um eine Kombination der durch die Reflexion des Sendesignals verursachten Komponenten der Empfangssignale durch jeden der Reflektoren der Struktur des zu untersuchenden Körpers in einer vorbestimmten Scanebene oder Scan-Schicht des zu untersuchenden Körpers, welche Scanebene bzw. Scan-Schicht parallel zur Ausbreitungsrichtung des Sendeimpulses und der Reflexionssignale ist, **dadurch gekennzeichnet, dass** das Verfahren folgende Schritte umfasst:

Definieren eines Satzes von vorbestimmten Reflexionspunkten (P1,1... Pn,n), die in einem vorbestimmten Abstand zueinander angeordnet sind und einen sich in der Scanebene oder Schicht erstreckenden Raster (200) von vorbestimmten Reflexionspunkten bilden, entlang derer der zu untersuchende Körper abgebildet wird; die Zeitverschiebung der Empfangssignale zur Bestimmung des Sendeimpulsreflexionssignals aus jedem der vorbestimmten Reflexionspunkte (P1,1... Pn,n) vorab in Abhängigkeit von den vorgegebenen relativen Abständen zwischen den einzelnen Reflexionspunkten (P1,1... Pn,n) definiert wird, welche Bestimmung des Reflexionssignals durch Kombination der Komponenten der Empfangssignale der einzelnen Empfangswandler (T1... Tn) erfolgt, welche Komponenten innerhalb der Zeitintervallen der Empfangssignale mit diesen Verzögerungen einfallen und welche Komponenten sich aus den entsprechenden Komponenten des Reflexionssignals ableiten, die durch jeden der vorbestimmten Reflexionspunkte bestimmt sind (P1,1... Pn,n); sukzessives Aussenden eines akustischen Sendeimpulses in Form einer sphärischen Welle aus jeweils einer Mehrzahl von Sendepunkten, die alle entlang der Anordnung von Sendewandlern (3) angeordnet sind; Bestimmen des Satzes von Reflexionssignalen aus den einzelnen Reflexionspunkten des Rasters (200) von vorbestimmten Reflexionspunkten (P1,1... Pn,n) für jeden sphärischen Sendeimpuls, der von einem anderen Übertragungspunkt ausgesendet wird, und separates Speichern dieser Sätze von Reflexionssignalen für jeden der von den einzelnen Sendepunkten gesendeten sphärischen Sendeimpulse; Erzeugung des Bildes entlang der Scan-Ebene bzw. Schicht des untersuchten Körpers durch Addition der von den einzelnen sphärischen Sendeimpulsen, die von den verschiedenen Sendepunkten ausgesendet werden, erzeugten

- Reflexionssignale der Sätze von Reflexionssignalen;  
Codieren des so erhaltenen Satzes von Pixeln oder Voxeln des Bildes als Videosignal und drahtloses Senden des Videosignals an eine entfernte Wiedergabe-/Anzeigeeinheit.
2. Verfahren zur Ultraschallbildfassung nach Anspruch 1, wobei das Bild entlang der Scan-Ebene bzw. Schicht des untersuchten Körpers durch den Mittelwert der Reflexionssignale der Sätze von Reflexionssignalen erzeugt wird, die von den sphärischen, von den verschiedenen Sendepunkten ausgesendeten Sendeimpulsen erzeugt werden.
  3. Verfahren zur Ultraschallbildfassung nach einem oder mehreren der vorhergehenden Ansprüche 1 oder 2, wobei die Summe oder der Mittelwert der Reflexionssignale der einzelnen Sätze von Reflexionssignalen für jeden der Reflexionspunkte (P1,1...Pn,n) getrennt berechnet wird, andernfalls wird die Summe oder der Mittelwert aus den Werten des Reflexionssignals jedes Reflexionspunktes (P1,1...Pn,n) berechnet, wie sie in den verschiedenen Sätzen von Reflexionssignalen gespeichert sind.
  4. Verfahren zur Ultraschallbildfassung nach einem oder mehreren der vorhergehenden Ansprüche 1 oder 3, wobei die Summe bzw. der Mittelwert der Reflexionssignale vor der Umwandlung in Bilddaten durch die Verarbeitungsmittel (113) berechnet wird.
  5. Verfahren zur Ultraschallbildfassung nach einem oder mehreren der vorhergehenden Ansprüche 1 oder 4, wobei die Reflexionssignale der einzelnen Sätze von Reflexionssignalen in Bilddaten umgewandelt und dann separat abgespeichert werden, wobei für jeden Satz von Reflexionssignalen unter Verwendung der aus den einzelnen Sätzen von Reflexionssignalen abgeleiteten Bilddaten die Summe bzw. der Mittelwert berechnet wird.
  6. Verfahren zur Ultraschallbildfassung nach einem oder mehreren der vorhergehenden Ansprüche 1 oder 5, wobei ein Teilraster (210) kleiner als dieses Raster (200) bestimmt wird, dessen Umfangspunkte mit zumindest einem Teil der Punkte des Rasters (200) zusammenfallen.
  7. Verfahren zur Ultraschallbildfassung nach Anspruch 6, wobei der Teilraster (210) sich aus so vielen Punkten oder mehr zusammensetzt, wie sie in diesem Raster (200) in dem von den Umfangspunkten des Teilrasters (210) begrenzten Bereich enthalten sind.
  8. Verfahren zur Ultraschallbildfassung nach einem oder mehreren der vorhergehenden Ansprüche 1 oder 7, wobei die Sendewandler (T1... Tn) auch als Empfangswandler (T1...Tn) wirken, Tn), wobei diese abwechselnd für die Übertragung und den Empfang von akustischen Signalen angesteuert werden.
  9. Verfahren zur Ultraschallbildfassung nach einem oder mehreren der vorhergehenden Ansprüche 1 oder 8, wobei die Verarbeitungsmittel (113) Mittel zum Bilden und Fokussieren eines akustischen Strahls auf die einzelnen Reflexionspunkte (P1,1... Pn,n), wobei diese Mittel als so genannte Empfangs-/Sendestrahlförmiger bekannt sind.
  10. Verfahren zur Ultraschallbildfassung nach einem oder mehreren der vorhergehenden Ansprüche 1 oder 9, wobei die Anordnung von Sendewandlern (3) eine zweidimensionale Anordnung ist, welche Anordnung von Wandlern (3) Abtastvolumina des untersuchten Körpers erzeugt, in denen akustische Impulse gesendet werden und von denen Reflexionsimpulse der gesendeten akustischen Impulse empfangen werden, wobei die vorgegebenen Reflexionspunkte (P1,1... Pn,n) in einem dreidimensionalen Raster (200) innerhalb des Abtastvolumens angeordnet sind, und wobei die Sendepunkte entlang der zweidimensionalen Oberfläche der Anordnung von Sendewandlern (3) angeordnet sind, und jeder Satz von Reflexionssignalen die Reflexionssignale der Reflexionspunkte des dreidimensionalen Rasters (200) von Reflexionspunkten (P1,1... Pn,n) zur Bildung eines dreidimensionalen Bildes umfasst.
  11. Verfahren nach einem oder mehreren der vorhergehenden Ansprüche 1 bis 10, **dadurch gekennzeichnet, dass** die einzelnen Schallimpulse von einer oder mehreren Teilgruppen von Wandlern der Anordnung übertragen werden, wobei jede der Teilgruppe eine geringere Anzahl von Wandlern aufweist als die Gesamtzahl der Wandler der Wandleranordnung.
  12. Verfahren nach Anspruch 11, **dadurch gekennzeichnet, dass** in wenigstens einer Teilgruppe von Wandlern zumindest der erste und/oder der letzte Wandler der Teilgruppe nicht mit dem ersten bzw. dem letzten der Wandler der Anordnung, in Bezug auf ihre Anordnung in der Aufstellung von Wandlern, zusammenfallen.
  13. Verfahren nach Anspruch 11 oder 12, **dadurch gekennzeichnet, dass** die Wandler mindestens einer Teilgruppe und die unwirksamen Wandlern oder Wandlern einer anderen Teilgruppe wechselweise angeordnet sind oder in unmittelbarer Nachbarschaft stehen.

14. Vorrichtung zur Ultraschall-Bilderfassung, die in das Gehäuse einer Ultraschallsonde für Ultraschall-Bildgebungsvorrichtungen integriert ist, wobei die Vorrichtung umfasst:

eine Anordnung von elektroakustischen Wandlern (3), die jeweils Ultraschallwellen aussenden, wenn sie mit einem elektrischen Anregungssignal versorgt werden und ein elektrisches Empfangssignal erzeugen, wenn auf diese eine Ultraschallwelle oder einen Ultraschallimpuls auftrifft, der beispielsweise durch Reflexion von daraus ausgesendeten Ultraschallwellen erzeugt wird;

die Anordnung von elektroakustischen Wandlern (3) mindestens eine Kommunikationsleitung zu einer Verarbeitungseinheit (112) aufweist, durch die jeder Wandler der Anordnung von Wandlern (3) Empfangssignale zu einer Verarbeitungseinheit (113) sendet, und mit einer Kommunikationsleitung, durch welche die von einer Erzeugungseinheit (112) erzeugten elektrischen Anregungssignale jedem Wandler der Anordnung von Wandlern (3) zur Anregung des Wandlers zur Übertragung von Ultraschallwellen zugeführt werden;

die Erzeugungseinheit (112) Anregungssignalerzeugungsmittel und Mittel zum Zuführen der Signale zu der Anordnung von Wandlern (3) aufweist,

wobei zumindest die Verarbeitungseinheit (113) in das Sondengehäuse eingepasst ist und Umwandlungsmittel zum Umwandeln von Empfangssignalen in ein Bild sowie Videosignalerzeugungsmitteln zur Erzeugung eines Bildes auf einer Anzeigeeinheit umfasst, drahtlose Kommunikationsmittel (4) zur Übertragung zwischen der Sonde und einer entfernten Einheit vorgesehen sind, die diese Bilder als Videosignale anzeigt und speichert,

**dadurch gekennzeichnet, dass**

die Verarbeitungsmittel einen Speicher umfassen, in dem Sequenzen von Zeitfenstern zur Anregung der einzelnen Wandler zur Übertragung von Ultraschallimpulsen gespeichert sind, welche Fenster derart definiert sind, dass ein akustischer Sendeimpuls aufeinanderfolgend in Form einer sphärischen Welle aus jeweils einer Mehrzahl von Sendepunkten, die alle entlang des Anordnung von Sendewandlern (3) angeordnet sind, gesendet wird und wobei Sequenzen von Zeitfenstern für den Empfang von Reflexionsimpulsen der Sendeimpulse gespeichert werden, welche Reflexionsimpulse von jedem Wandler während des entsprechenden Empfangszeitfensters des Wandlers in Empfangssignale umgewandelt werden und welche Empfangszeitfenster für jeden Punkt eines Satz-

zes von vorbestimmten Reflexionspunkten ( $P_{1,1} \dots P_{n,n}$ ), die in einem vorbestimmten Abstand voneinander angeordnet sind, berechnet werden, und einen Raster (200) von vorbestimmten Reflexionspunkten bilden, die sich in der Scan-Ebene bzw. Schicht erstrecken, entlang derer der zu untersuchende Körper abgebildet wird, so dass durch die aufeinanderfolgende Übertragung eines akustischen Sendeimpulses in Form einer sphärischen Welle aus jeweils einer Mehrzahl von Sendepunkten, die alle entlang des Anordnung von Sendewandlern (3) angeordnet sind, der Satz von Reflexionssignalen aus den einzelnen Reflexionspunkten ( $P_{1,1} \dots P_{n,n}$ ) des Rasters (200) von vorgegebenen Reflexionspunkten für jeden von einem anderen Übertragungspunkt übertragenen sphärischen Sendeimpuls definiert ist, oder die Umwandlungsmittel in Echtzeit und jedes Mal die Zeitfenster berechnen und die Umwandlungsmittel einen Bilderzeugungsspeicher umfassen, wobei die Sätze von Reflexionssignalen für jeden der von den einzelnen Sendepunkten gesendeten sphärischen Sendeimpulse mittels der Speichermittel gespeichert werden und das Bild entlang der Scan-Ebene bzw. Schicht des zu untersuchenden Körpers durch Addition der Reflexionssignale der Sätze von Reflexionssignalen erzeugt wird, welche durch die einzelnen, von den verschiedenen Sendepunkten ausgesendeten sphärischen Sendeimpulse erzeugt werden.

#### 35 Revendications

1. Procédé permettant l'acquisition d'images ultrasonores, ledit procédé comportant l'émission d'impulsions ultrasonores vers un corps examiné ;  
lesdites impulsions étant générées par des transducteurs d'émission ( $T_1 \dots T_n$ ), regroupés dans un réseau de transducteurs d'émission (3) ;  
lesdits transducteurs d'émission ( $T_1 \dots T_n$ ) étant connectés chacun à un générateur d'impulsions d'excitation électrique et convertissant lesdites impulsions électriques en impulsions acoustiques ;  
la réception des impulsions acoustiques de réflexion générées suite à la réflexion des impulsions d'émission par les éléments structuraux du corps sous examen ayant des caractéristiques de réflecteurs acoustiques étant effectuée par des transducteurs de réception ( $T_1 \dots T_n$ ) ;  
lesdits transducteurs de réception ( $T_1 \dots T_n$ ) étant regroupés dans un réseau desdits transducteurs de réception (3) ;  
et lesdits transducteurs de réception ( $T_1 \dots T_n$ ) étant chacun connecté à des moyens de traitement (113) de signaux de réception ;

chaque transducteur de réception ( $T_1 \dots T_n$ ) fournissant auxdits moyens de traitement de signaux de réception électriques générés par l'excitation dudit transducteur ( $T_1 \dots T_n$ ) suite à la réception du signal acoustique de réflexion incident sur ledit transducteur de réception ( $T_1 \dots T_n$ );

les signaux de réception fournis par les transducteurs de réception individuels ( $T_1 \dots T_n$ ) étant combinés par lesdits moyens de traitement de signaux de réception (113) et ladite combinaison ayant lieu avec des décalages temporels relatifs des signaux de réception des transducteurs de réception individuels ( $T_1 \dots T_n$ ), lesdits décalages étant tels que les composants individuels des signaux de réception des transducteurs de réception individuels ( $T_1 \dots T_n$ ) soient combinés les uns aux autres, lesdits composants correspondant au composant du signal de réflexion généré par la réflexion de l'impulsion d'émission par un réflecteur prédéterminé de la structure du corps sous examen, qui se trouve dans une position prédéterminée par rapport au réseau de transducteurs de réception (3);

et la dite étape consistant à combiner les signaux de réception des transducteurs de réception individuels ( $T_1 \dots T_n$ ) étant répétée avec des décalages temporels différents, pour obtenir une combinaison des composantes du signal de réception déterminées par la réflexion du signal d'émission par chacun des réflecteurs de la structure du corps sous examen dans un plan de balayage prédéterminé ou une tranche prédéterminée du corps sous examen, ledit plan de balayage ou ladite tranche étant parallèle à la direction de propagation de l'impulsion d'émission et des signaux de réflexion

**caractérisé en ce que** le procédé comporte les étapes consistant à :

définir un ensemble de points de réflexion prédéterminés ( $P_{1,1} \dots P_{n,n}$ ) agencés à une distance prédéterminée l'un de l'autre et former une grille (200) de points de réflexion prédéterminés s'étendant dans le plan de balayage ou la tranche le long desquels les images du corps sous examen sont acquises; le décalage temporel des signaux de réception pour déterminer le signal de réflexion des impulsions d'émission pour chacun desdits points de réflexion prédéterminés ( $P_{1,1} \dots P_{n,n}$ ) étant défini préalablement selon les distances relatives prédéterminées entre les points de réflexion individuels ( $P_{1,1} \dots P_{n,n}$ ), ladite détermination du signal de réflexion ayant lieu par la combinaison des composantes des signaux de réception des transducteurs de réception individuels ( $T_1 \dots T_n$ ), lesdites composantes étant comprises dans des intervalles de temps des signaux de réception ayant lesdits retards et lesdites composantes dérivant des composantes correspondantes du

signal de réflexion déterminées par chacun desdits points de réflexion prédéterminés ( $P_{1,1} \dots P_{n,n}$ );

émettre en suite une impulsion d'émission acoustique en forme d'onde sphérique de chacun d'une pluralité de points d'émission le long du réseau de transducteurs d'émission (3);

déterminer l'ensemble de signaux de réflexion à partir des points de réflexion individuels de ladite grille (200) de points de réflexion prédéterminés ( $P_{1,1} \dots P_{n,n}$ ) pour chaque impulsion d'émission sphérique émise par un autre point de transmission et stocker séparément lesdits ensembles de signaux de réflexion pour chacune des impulsions d'émission sphériques émises par les points d'émission individuels;

générer l'image le long du plan de balayage ou de la tranche du corps sous examen par la somme des signaux de réflexion des ensembles des signaux de réflexion générés par les impulsions de transmission sphériques individuels émis par les différents points d'émission; coder l'ensemble de pixels ou de voxels de ladite image ainsi obtenue sous forme de signal vidéo et émettre le signal vidéo en mode sans fils vers une unité de reproduction / affichage.

2. Procédé permettant l'acquisition d'images ultrasonores selon la revendication 1, dans lequel l'image est générée le long du plan de balayage ou de la tranche du corps sous examen par la moyenne des signaux de réflexion des ensembles de signaux de réflexion générés par les impulsions d'émission sphériques émises par les différents points d'émission.
3. Procédé permettant l'acquisition d'images ultrasonores selon une ou plusieurs des revendications précédentes 1 et 2, dans lequel ladite somme ou ladite moyenne des signaux de réflexion des ensembles individuels des signaux de réflexion est calculée séparément pour chacun des points de réflexion ( $P_{1,1} \dots P_{n,n}$ ), ou la somme ou la moyenne est calculée à partir des valeurs du signal de réflexion de chaque point de réflexion ( $P_{1,1} \dots P_{n,n}$ ) stocké dans les différents ensembles de signaux de réflexion.
4. Procédé permettant l'acquisition d'images ultrasonores selon une ou plusieurs des revendications précédentes 1 à 3, dans lequel ladite somme ou moyenne des signaux de réflexion est calculée en amont de la conversion en données d'image par lesdits moyens de traitement (113).
5. Procédé permettant l'acquisition d'images ultrasonores selon une ou plusieurs des revendications précédentes 1 à 4, dans lequel les signaux de réflexion des ensembles individuels de signaux de réflexion

- sont convertis en données d'image et ensuite stockés séparément, pour chaque ensemble de signaux de réflexion, ladite somme ou moyenne étant calculée à l'aide de des données d'image tirées des ensembles individuels de signaux de réflexion.
6. Procédé permettant l'acquisition d'images ultrasonores selon une ou plusieurs des revendications précédentes 1 à 5, dans lequel une sous-grille (210) plus petite que ladite grille (200) est déterminée, dont les points périphériques coïncident avec au moins une partie des points de ladite grille (200).
7. Procédé d'acquisition d'images ultrasonores selon la revendication 6, dans lequel ladite sous-grille (210) est composée d'un nombre de points égal ou supérieur que le nombre de points contenus dans ladite grille (200), dans la zone délimitée par les points périphériques de ladite sous-grille (210) ou plus.
8. Procédé d'acquisition d'images ultrasonores selon une ou plusieurs des revendications précédentes 1 à 7, dans lequel les transducteurs d'émission ( $T_1 \dots T_n$ ) font également fonction de transducteurs de réception ( $T_1 \dots T_n$ ) ceux-ci étant alternativement actionnés pour l'émission et la réception de signaux acoustiques.
9. Procédé d'acquisition d'images ultrasonores selon une ou plusieurs des revendications précédentes 1 à 8, dans lequel les moyens de traitement (113) comprennent des moyens pour former et focaliser un faisceau acoustique sur les points de réflexion individuels ( $P_{1,1} \dots P_{n,n}$ ) connus comme des formateurs de faisceaux de réception / émission.
10. Procédé d'acquisition d'images ultrasonores selon une ou plusieurs des revendications précédentes 1 à 9, dans lequel le réseau de transducteurs d'émission et de réception (3) est un réseau bidimensionnel, ledit réseau de transducteurs (3) générant des volumes de balayage du corps sous examen, dans lequel les impulsions acoustiques sont émises et à partir desquelles sont reçues les impulsions de réflexion des impulsions acoustiques émises, le points de réflexion prédéterminés ( $P_{1,1} \dots P_{n,n}$ ) étant agencés dans une grille tridimensionnelle (200) à l'intérieur du volume de balayage, et les points d'émission étant agencés le long de la surface bidimensionnelle du réseau de transducteurs d'émission (3), chaque ensemble de signaux de réflexion comprenant les signaux de réflexion des points de réflexion de la grille tridimensionnelle (200) des points de réflexion ( $P_{1,1} \dots P_{n,n}$ ) pour former une image tridimensionnelle.
11. Procédé selon une ou plusieurs des revendications précédentes 1 à 10, **caractérisé en ce que** les impulsions acoustiques individuelles sont émises par un ou plusieurs sous-ensembles de transducteurs du réseau, chacun desdits sous-ensembles comporte un nombre de transducteurs inférieur que le nombre total de transducteurs du réseau de transducteurs.
12. Procédé selon la revendication 11, **caractérisé en ce que**, dans au moins un sous-ensemble de transducteurs, au moins le premier et/ou le dernier transducteur du sous-ensemble ne coïncident pas respectivement avec le premier ou le dernier des transducteurs du réseau, avec référence à leur disposition dans le réseau de transducteurs.
13. Procédé selon la revendication 11 ou 12, **caractérisé en ce que** les transducteurs d'au moins un sous-ensemble sont alternés avec des transducteurs hors de fonctionnement ou des transducteurs d'un autre sous-ensemble, ou sont directement adjacents les uns aux autres.
14. Appareil pour l'acquisition d'images ultrasonores intégré dans le boîtier d'une sonde échographique pour appareil d'imagerie par ultrasons, ladite sonde comprenant :
- un réseau de transducteurs électroacoustiques (3), chacun desquels émet des ondes ultrasonores dès qu'il est alimenté par un signal d'excitation électrique et génère un signal électrique de réception lorsqu'il reçoit une onde ou une impulsion ultrasonore incidente générée par exemple par la réflexion d'ondes ultrasonores émises de celui-ci ;
- ledit réseau de transducteurs électroacoustiques (3) étant pourvu d'au moins une ligne de communication vers une unité de traitement (112) par laquelle chaque transducteur dudit réseau de transducteurs (3) alimente des signaux de réception à une unité de traitement (113), et d'une ligne de communication par laquelle les signaux électriques d'excitation générés par une unité de génération (112) sont alimentés à chaque transducteur dudit réseau de transducteurs (3) pour exciter le transducteur à émettre des ondes ultrasonores ;
- ladite unité de génération (112) comprend des moyens de génération de signaux d'excitation et des moyens d'alimentation desdits signaux audit réseau de transducteurs (3), dans lequel au moins ladite unité de traitement (113) est insérée dans le boîtier de sonde et comprend des moyens de conversion pour convertir des signaux de réception en image, aussi bien que des moyens de génération de signaux vidéo

pour générer une image sur une unité d'affichage, des moyens de communication sans fil (4) étant prévus pour la transmission entre ladite sonde et une unité distante d'affichage, stockant lesdites images en forme de signaux vidéo, **caractérisé en ce que** les moyens de traitement comprennent une mémoire dans laquelle sont stockées des séquences de fenêtres temporelles pour exciter les transducteurs individuels à émettre des impulsions ultrasonores, lesdites fenêtres étant définies de façon à déterminer la transmission consécutive d'impulsions acoustiques en forme d'onde sphérique le long du réseau de transducteurs d'émission (3), et dans laquelle sont stockées des séquences de fenêtres temporelles pour la réception d'impulsions de réflexion des impulsions émises, lesdites impulsions de réflexion sont converties en signaux de réception par chaque transducteur, et lesdites fenêtres temporelles de réception étant calculées préalablement pour chaque point d'un ensemble de points de réflexion prédéterminés ( $P_{1,1} \dots P_{n,n}$ ) agencés à une distance prédéterminée l'un de l'autre, formant une grille (200) de points de réflexion prédéterminés s'étendant dans le plan de balayage ou la tranche le long desquels les images du corps sous examen sont acquises, de manière que, par l'émission consécutive d'une impulsion d'émission acoustique en forme d'onde sphérique depuis chacun d'une pluralité de points d'émission agencés le long du réseau de transducteurs d'émission (3), l'ensemble de signaux de réflexion est défini à partir des points de réflexion individuels ( $P_{1,1} \dots P_{n,n}$ ) de ladite grille (200) de points de réflexion prédéterminés pour chaque impulsion de transmission sphérique émise par un point d'émission différent, ou lesdits moyens de conversion calculent, en temps réel et à chaque fois, lesdites fenêtres temporelles, et lesdits moyens de conversion comprennent une mémoire de formation d'images, dans laquelle lesdits ensembles de signaux de réflexion pour chacune des impulsions de transmission sphériques émises par les points de transmission individuels sont stockées par lesdits moyens de stockage et l'image le long du plan de balayage ou de la tranche du corps sous examen est générée par la somme des signaux de réflexion des ensembles de signaux de réflexion générés par les impulsions de transmission sphériques individuelles émises par les différents points d'émission.

5

10

15

20

25

30

35

40

45

50

55

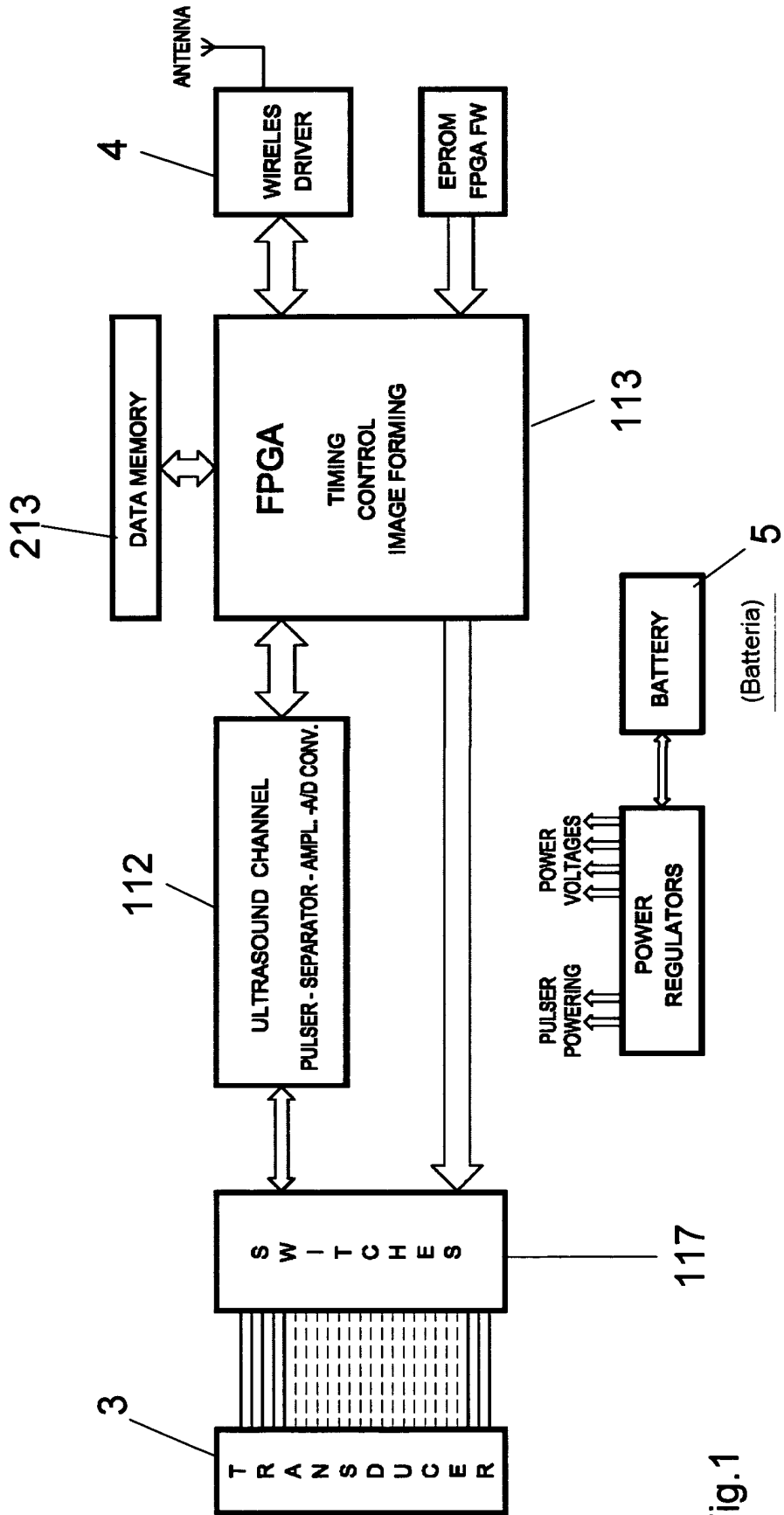

Fig.1

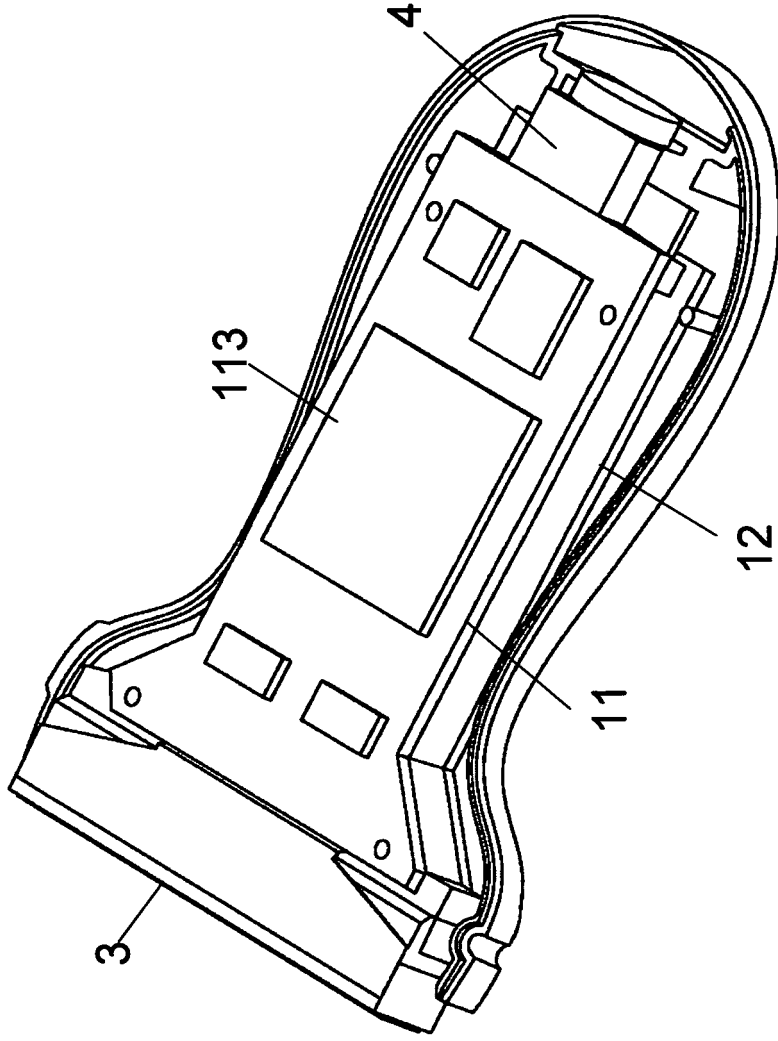

Fig.2

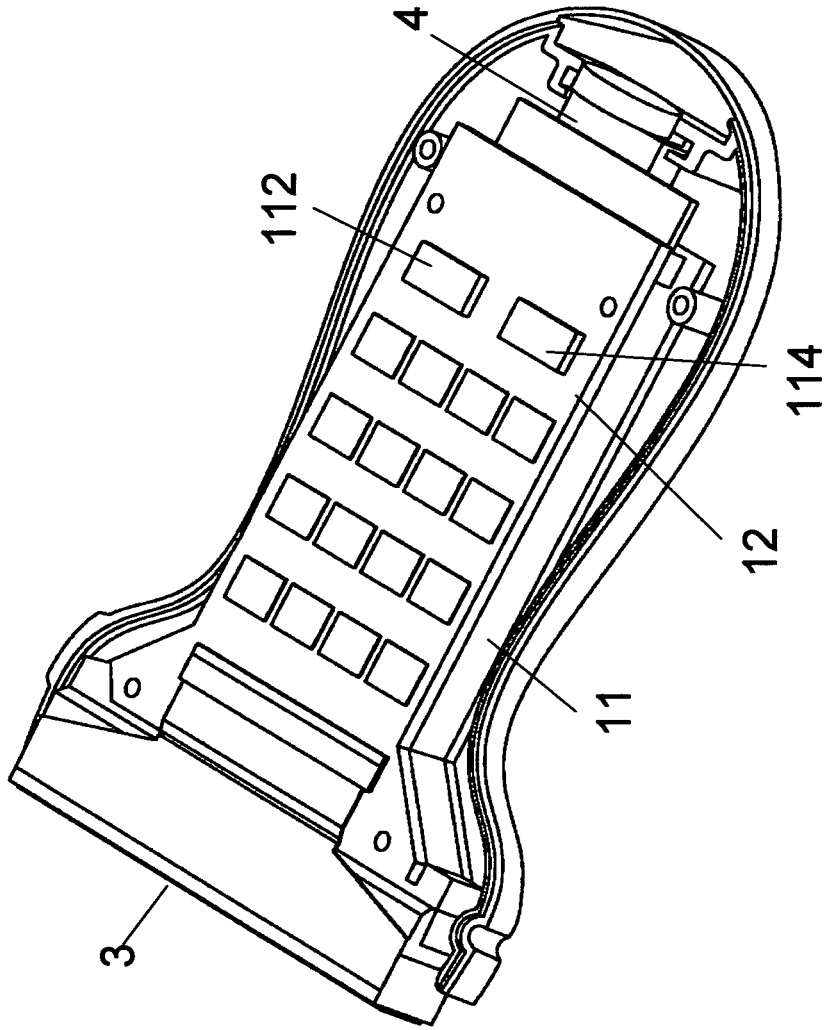

Fig.3

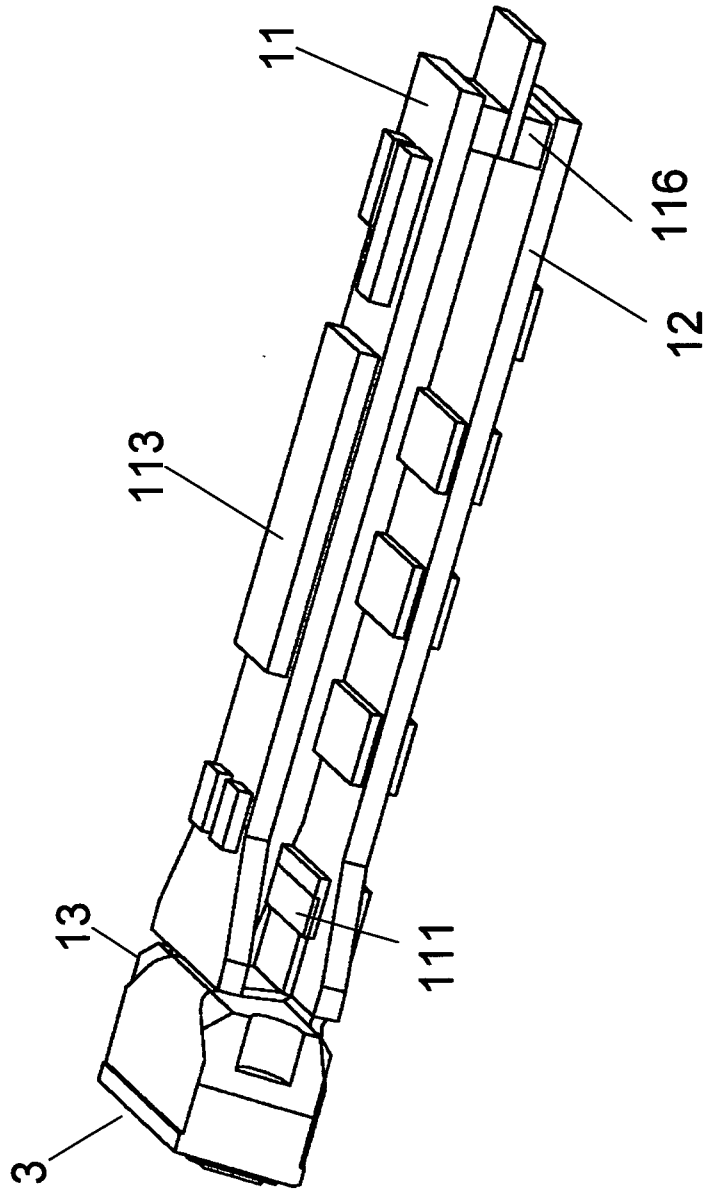

Fig.4

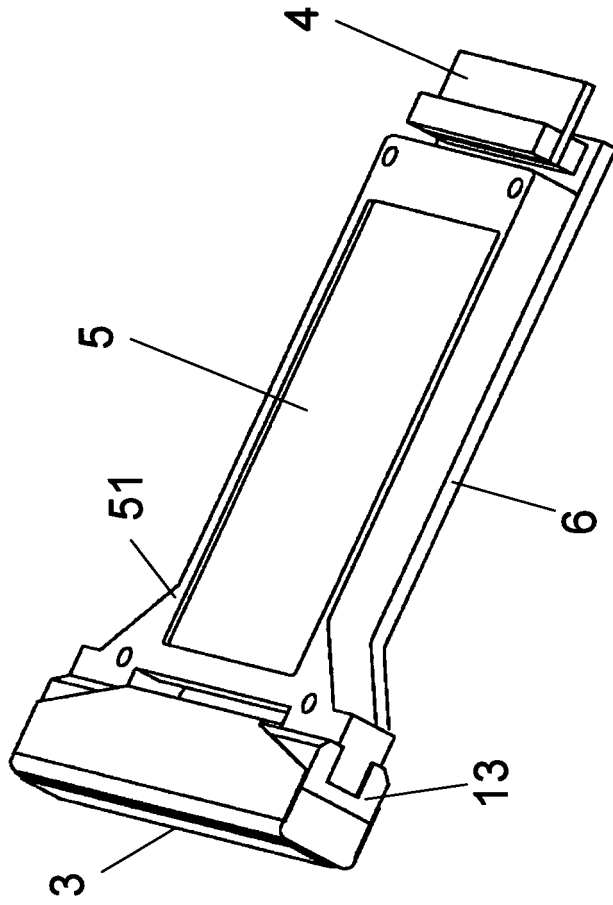

Fig.5

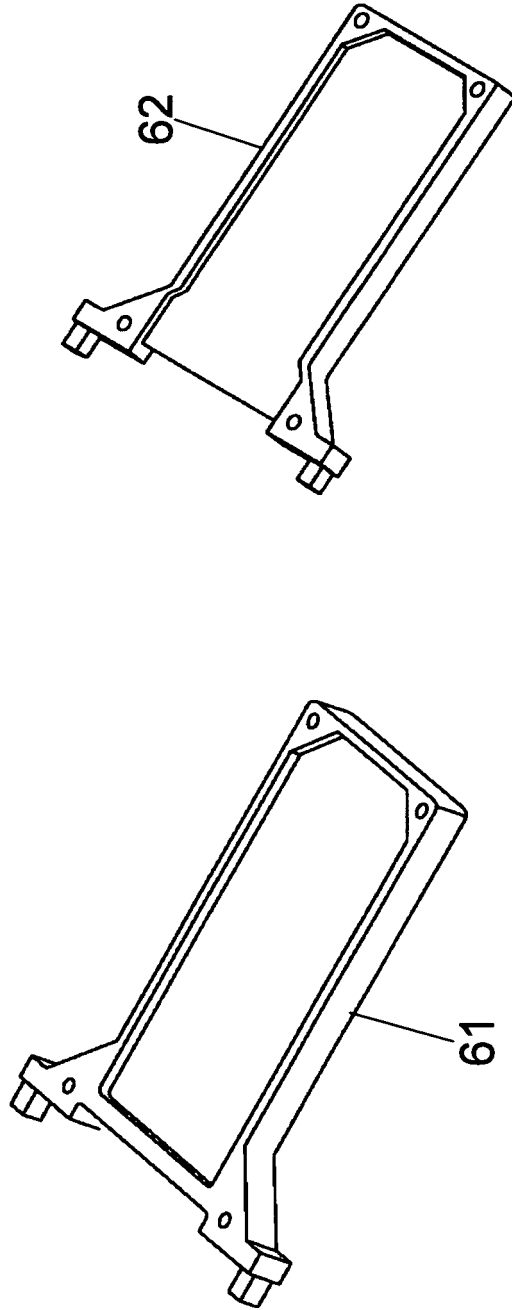

Fig.6

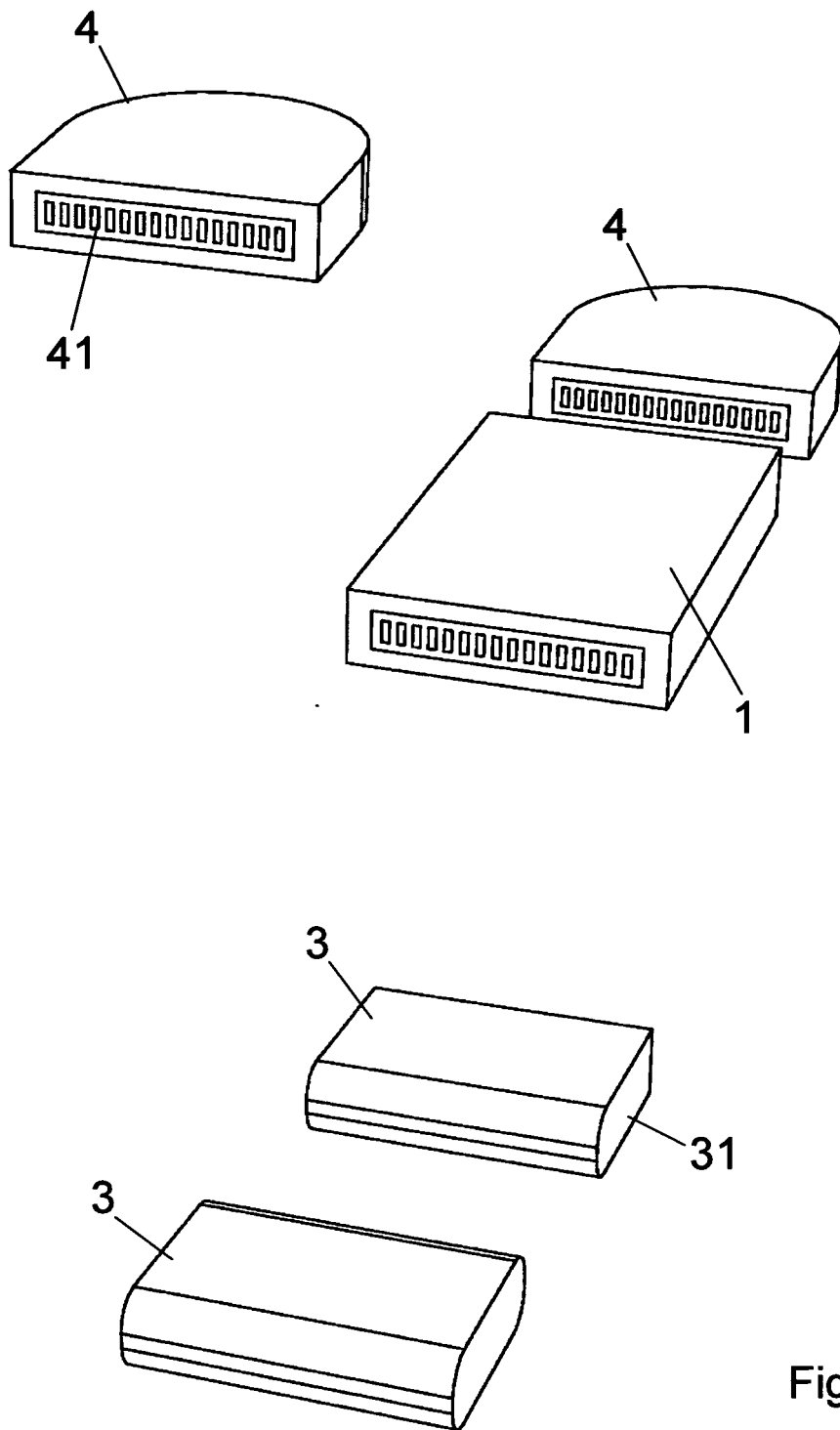

Fig.7

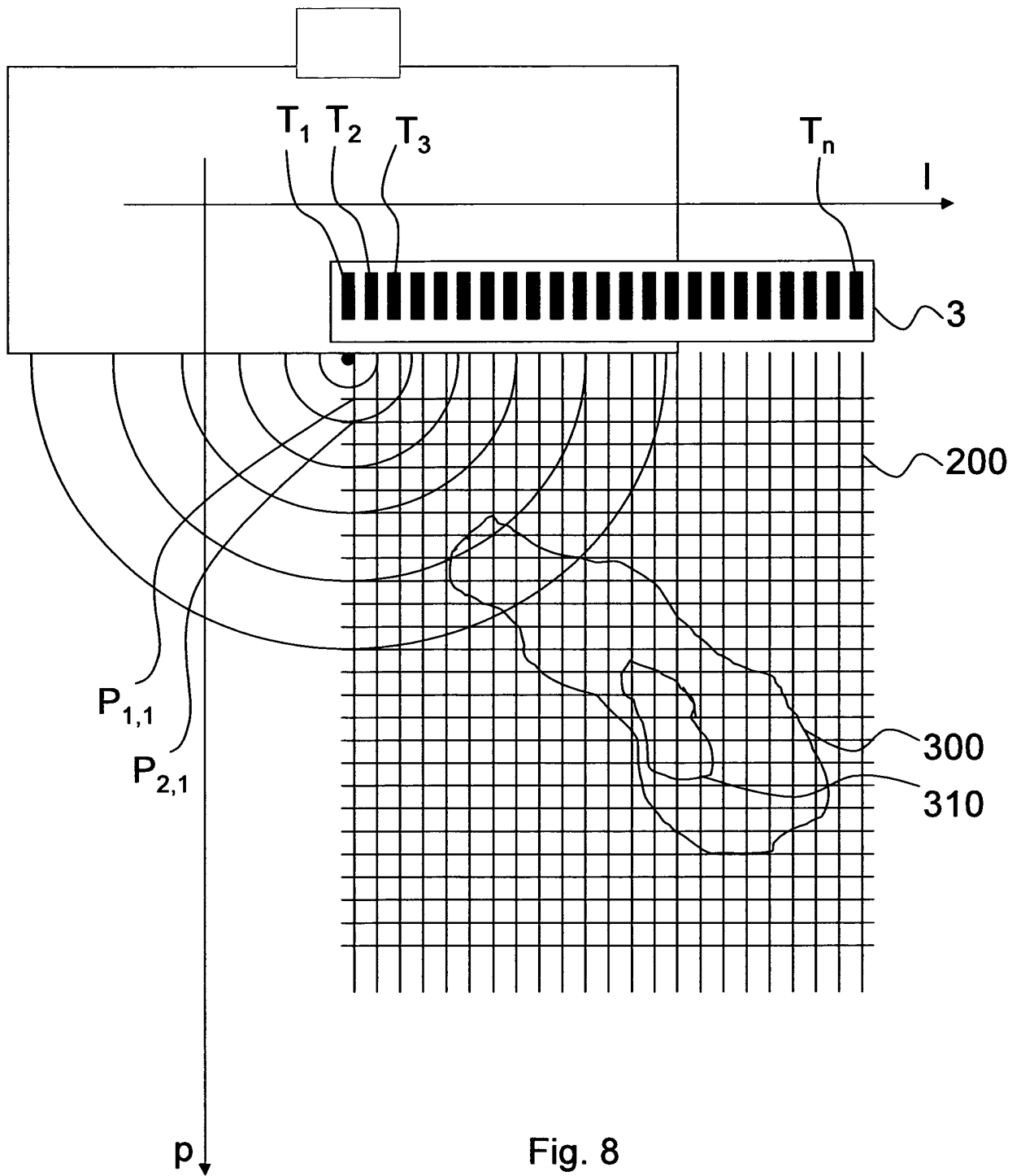

Fig. 8

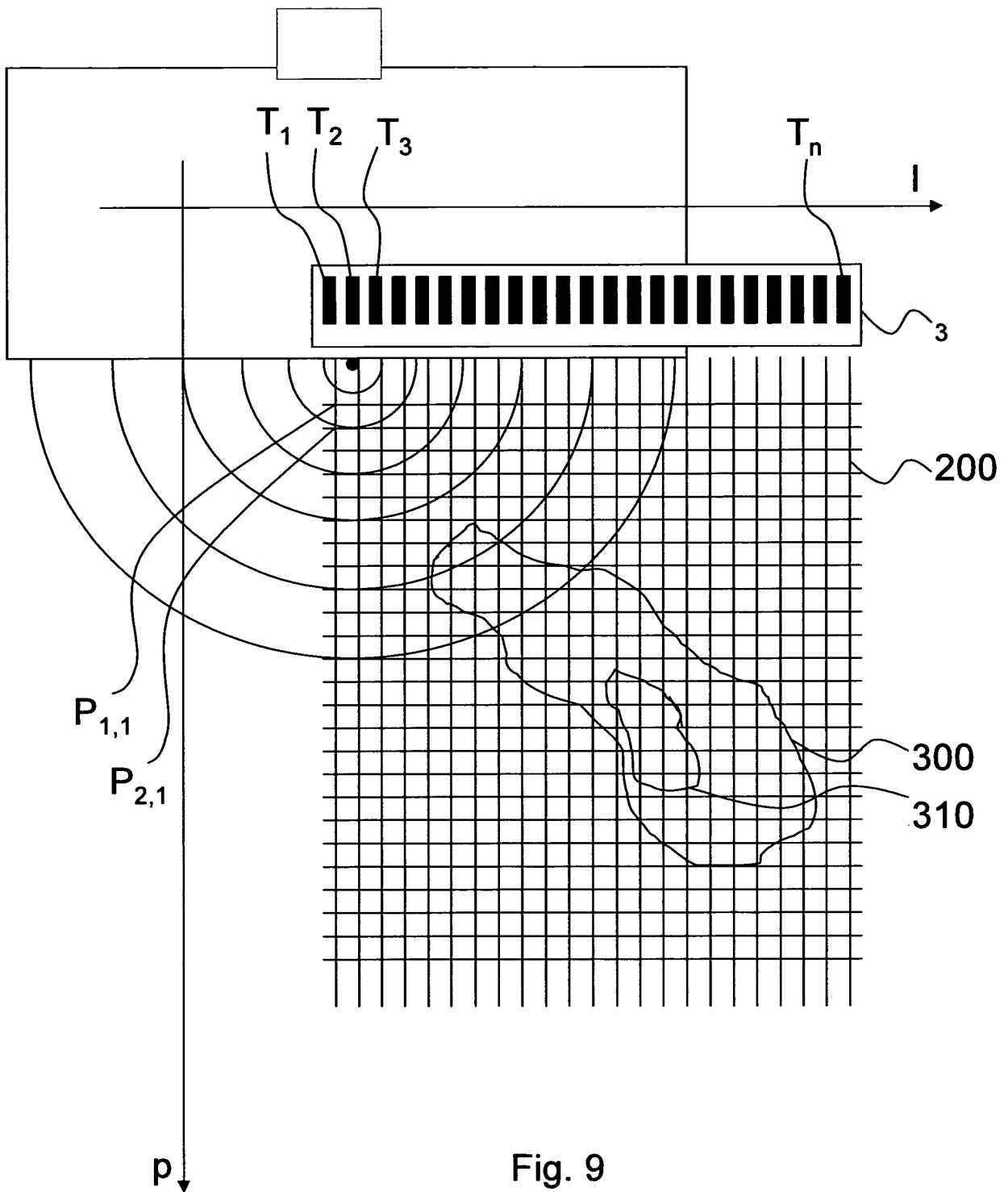

Fig. 9

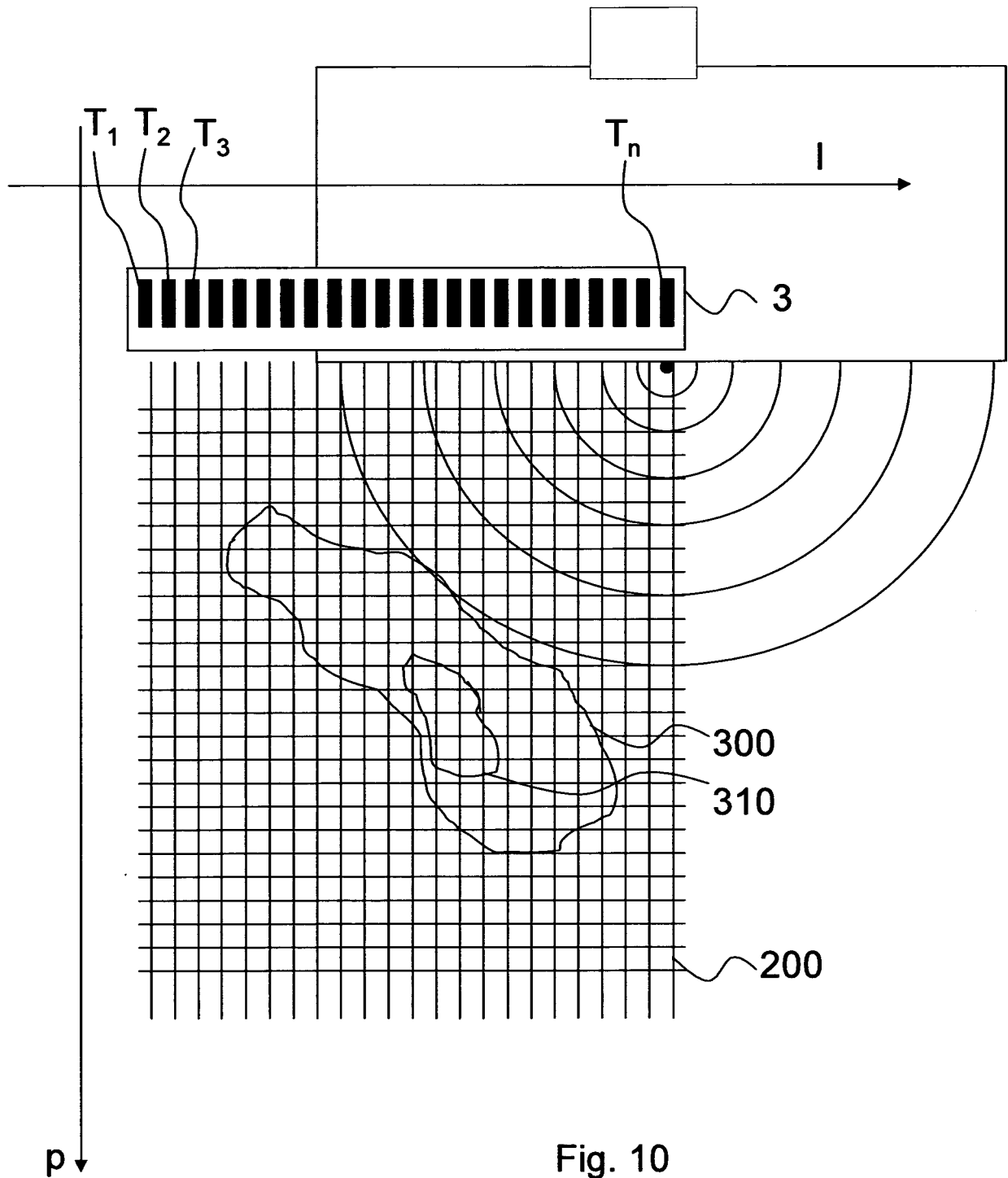

Fig. 10

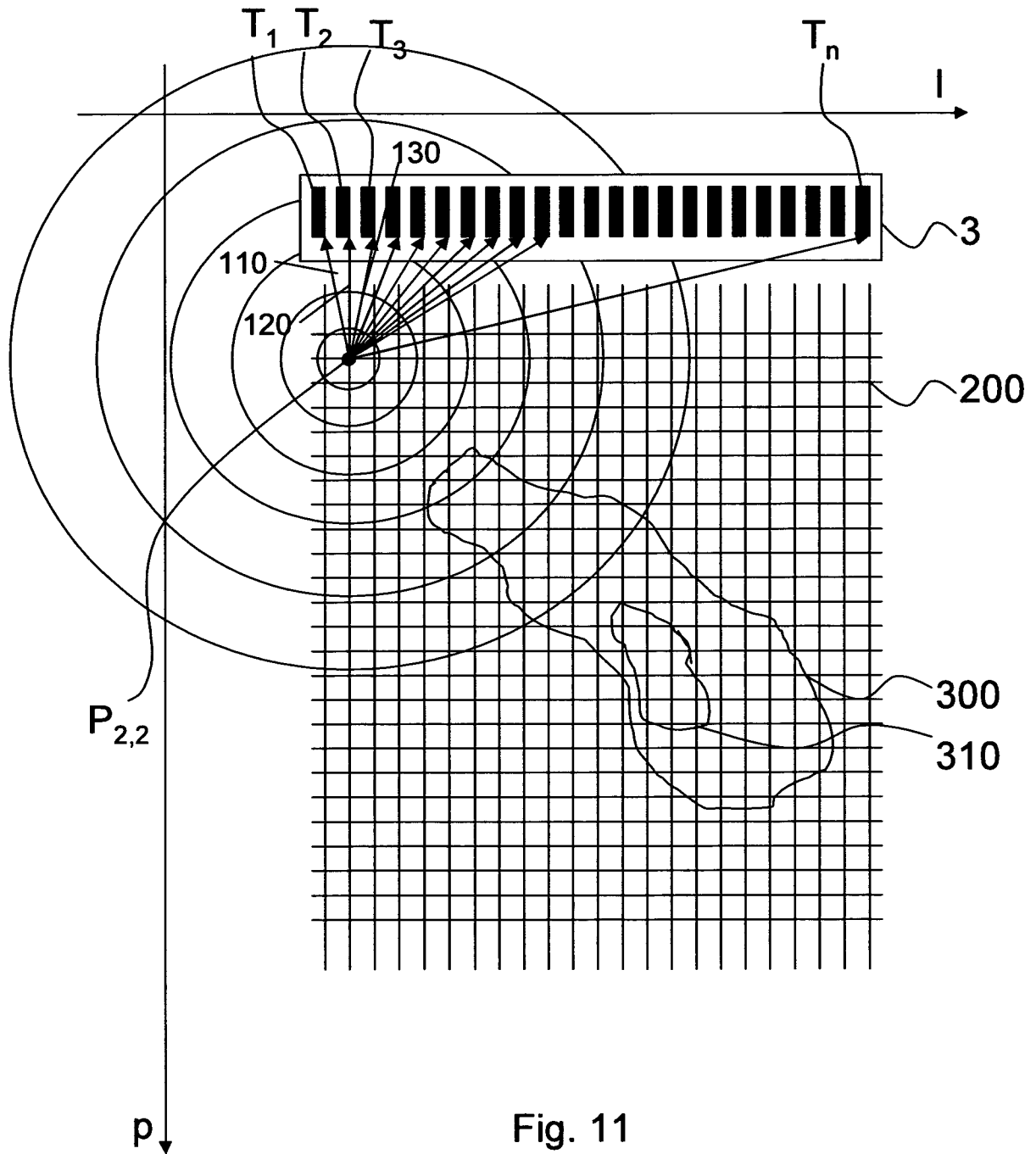

Fig. 11

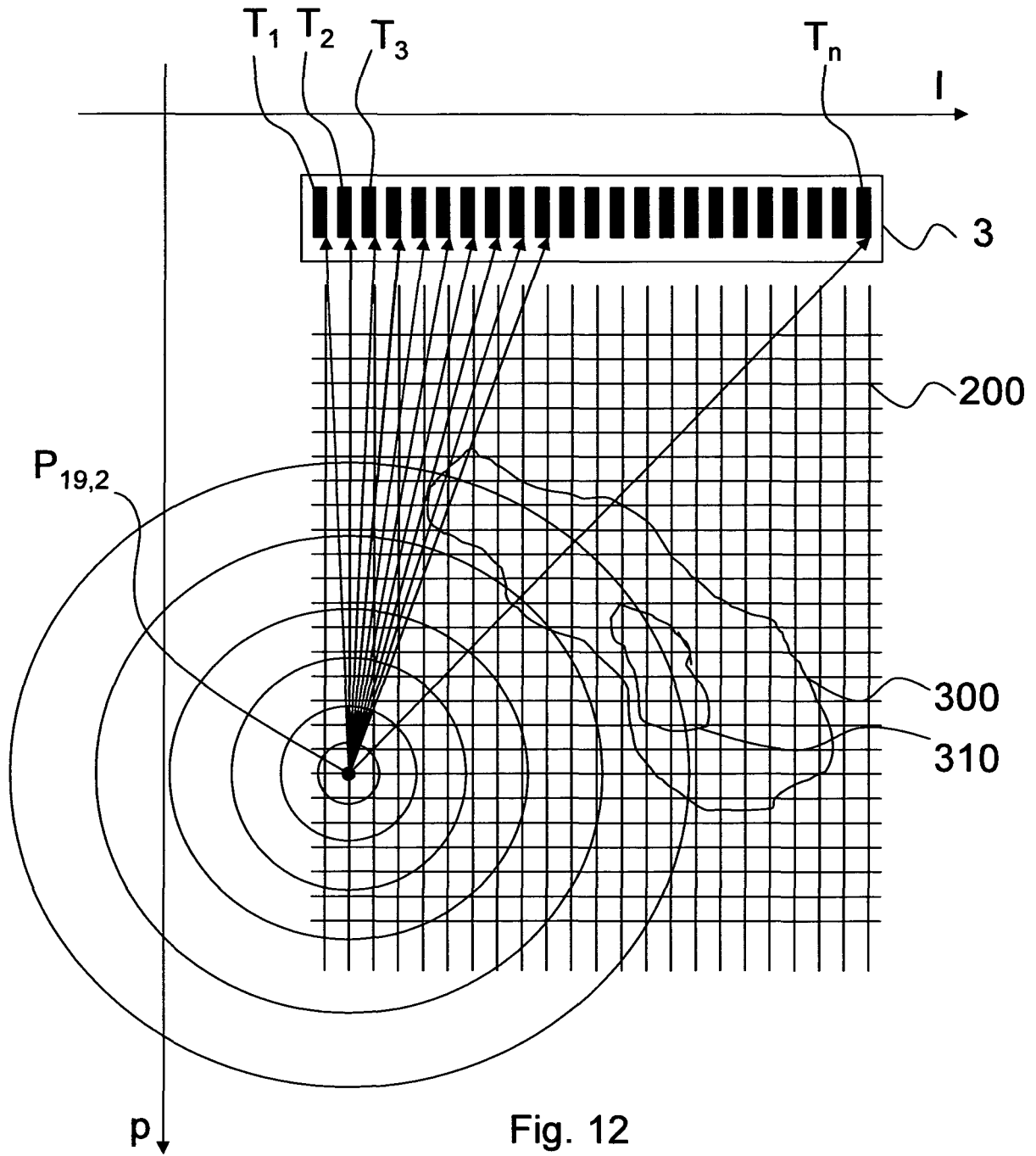

Fig. 12

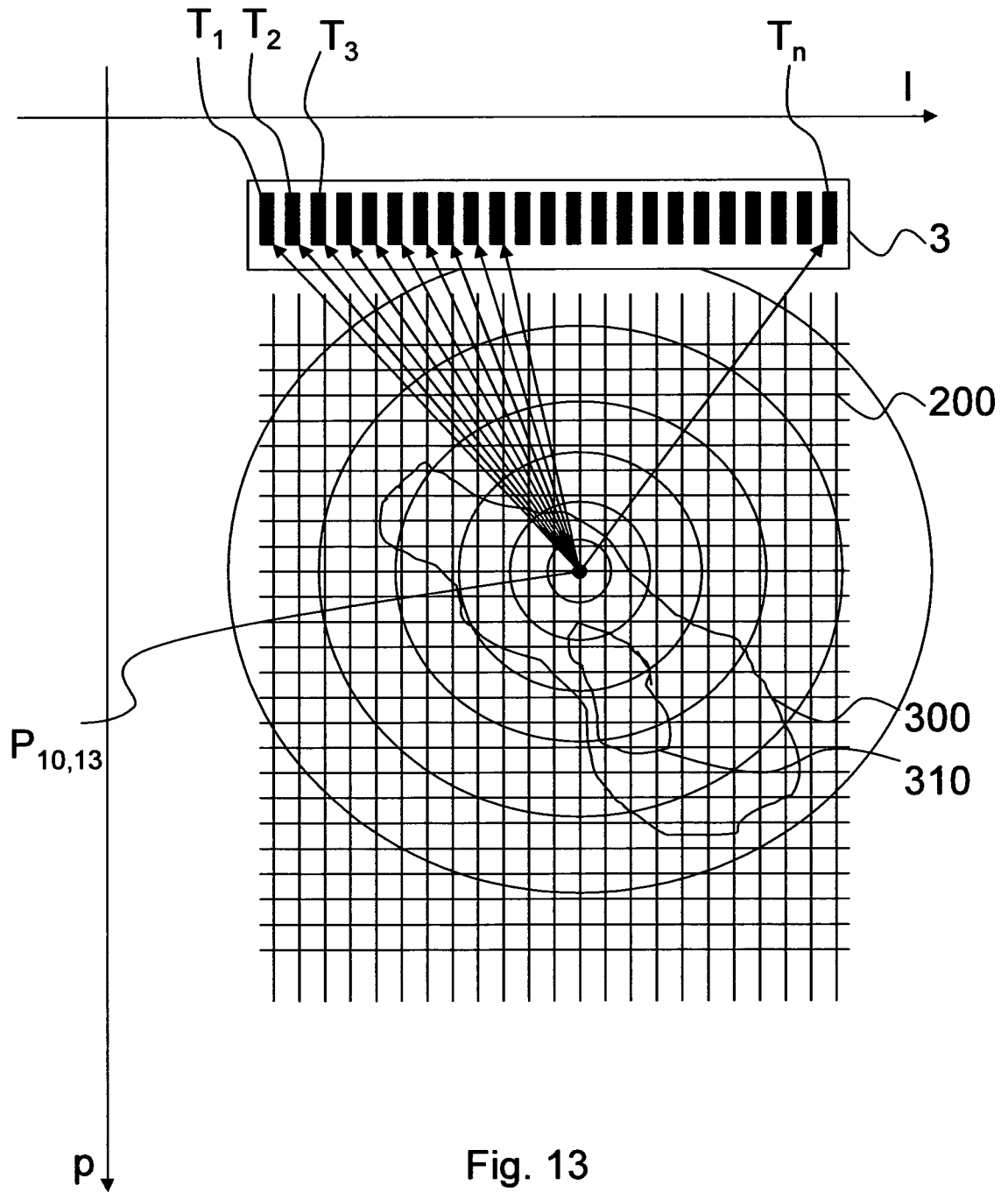

Fig. 13

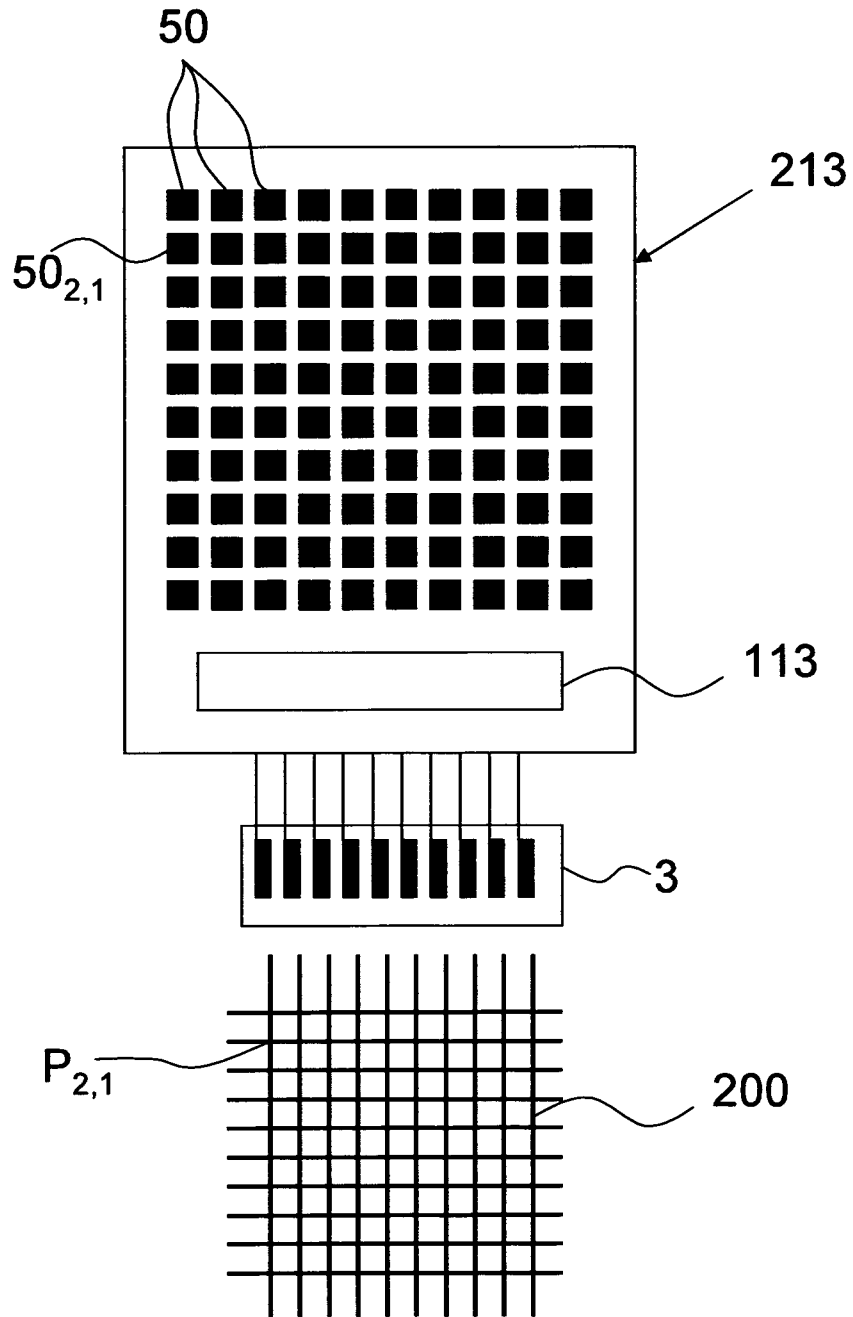

Fig. 14

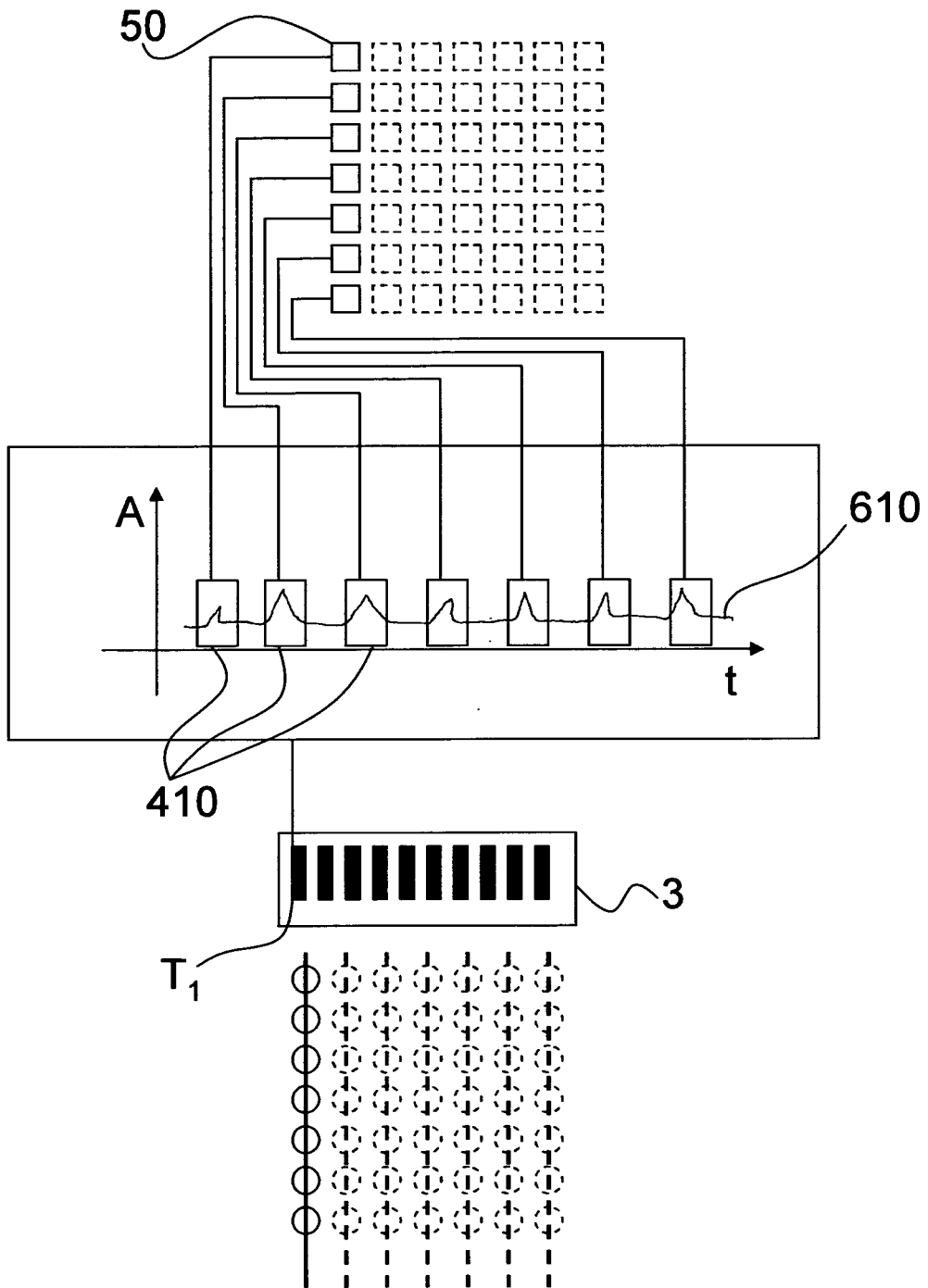

Fig. 15

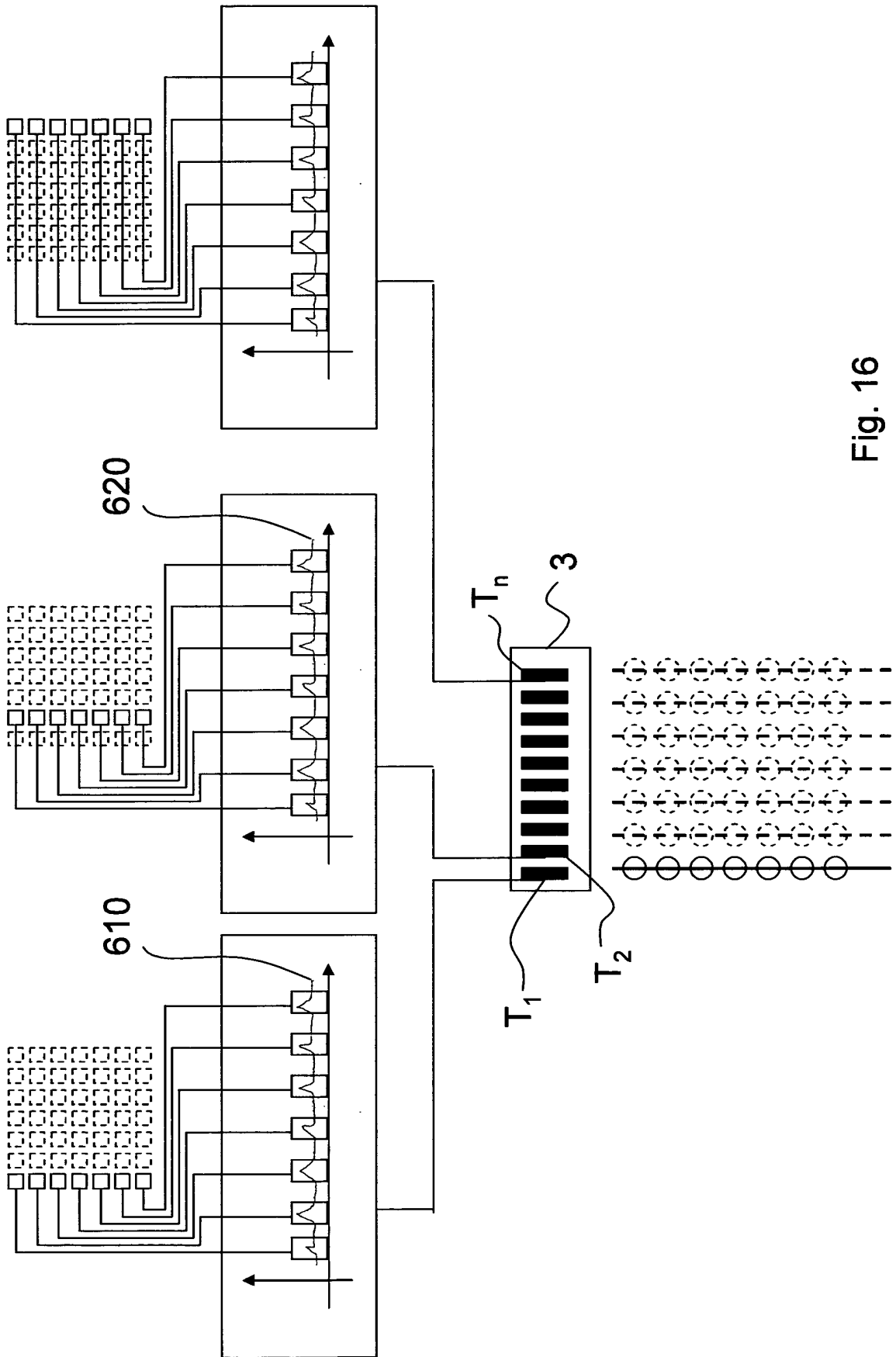

Fig. 16

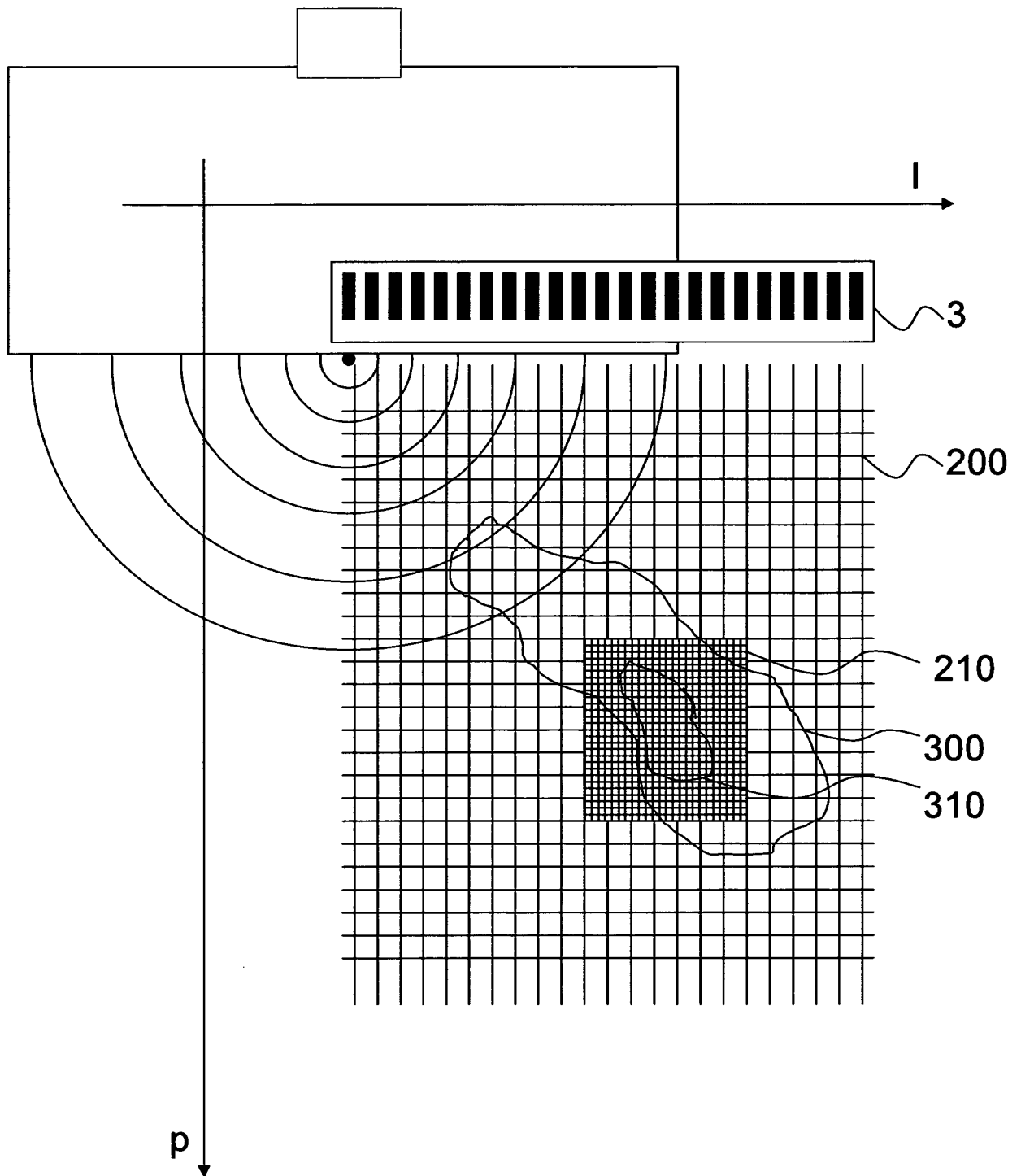

Fig. 17

**REFERENCES CITED IN THE DESCRIPTION**

*This list of references cited by the applicant is for the reader's convenience only. It does not form part of the European patent document. Even though great care has been taken in compiling the references, errors or omissions cannot be excluded and the EPO disclaims all liability in this regard.*

**Patent documents cited in the description**

- US 2002016545 A [0009]
- US 2003139664 A [0010]
- EP 2053418 A [0011]
- US 2008114253 A [0013]
- US 20020016545 A [0018]

**Non-patent literature cited in the description**

- Signals, Systems and Computers. **ELLIS M.A. et al.** 42nd Asilomar Conference. IEEE, 26 October 2008 [0012]
- Time domain Optimized Near-field Estimator for Ultrasound Imaging: Initial Development and Results. **FRAMNCESCO VIOLA et al.** IEEE Transactions on Medical Imaging. IEEE Services Center, vol. 27, 99-110 [0012]

专利名称(译)	一种用于超声图像采集的方法和装置		
公开(公告)号	<a href="#">EP2568883A2</a>	公开(公告)日	2013-03-20
申请号	EP2011725965	申请日	2011-05-05
[标]申请(专利权)人(译)	百胜集团		
申请(专利权)人(译)	ESAOTE S.P.A.		
当前申请(专利权)人(译)	ESAOTE S.P.A.		
[标]发明人	CEROFOLINI MARINO		
发明人	CEROFOLINI, MARINO		
IPC分类号	A61B8/00 A61B5/00 G10K11/34 G01S7/52 G01S15/89		
CPC分类号	A61B8/00 A61B8/4411 A61B8/4444 A61B8/4455 A61B8/4472 A61B8/4483 A61B8/483 A61B8/565 G01S7/003 G01S7/52026 G01S7/5208 G01S15/8915 G01S15/8954 G01S15/8977 G01H3/125		
优先权	102010901836790 2010-05-07 IT 102010901836789 2010-05-07 IT		
其他公开文献	EP2568883B1		
外部链接	<a href="#">Espacenet</a>		

#### 摘要(译)

用于超声图像采集的装置集成到超声探头的壳体中，该超声探头包括电声换能器阵列，其发射和接收超声脉冲。该阵列与馈送接收信号的处理单元通信，并连接到产生用于激励超声波传输的信号单元。在本发明的一个方面中，至少处理单元装配到探头壳体中并且被配置为将接收信号转换为图像，并且生成用于在显示单元上生成图像的视频信号。可以无线地操作探头和显示并可能将图像存储为视频信号的远程单元之间的传输。