



(11) **EP 1 681 020 B1**

(12) **EUROPEAN PATENT SPECIFICATION**

(45) Date of publication and mention of the grant of the patent:
04.06.2008 Bulletin 2008/23

(51) Int Cl.:
A61B 8/14 ^(2006.01) **A61B 8/00** ^(2006.01)
A61B 8/12 ^(2006.01)

(21) Application number: **05100286.3**

(22) Date of filing: **18.01.2005**

(54) **Ultrasonic imaging method and probe for 3D gynecologic inspection**

Verfahren zur Ultraschallabbildung und Sonde zur 3D gynäkologischen Untersuchung

Méthode d'imagerie ultrasonique et sonde pour inspection 3D gynécologique

(84) Designated Contracting States:
AT BE BG CH CY CZ DE DK EE ES FI FR GB GR HU IE IS IT LI LT LU MC NL PL PT RO SE SI SK TR

(43) Date of publication of application:
19.07.2006 Bulletin 2006/29

(73) Proprietor: **Esaote S.p.A.**
20100 Milano (IT)

(72) Inventor: **Cerofolini, Marino**
52010 Subbiano (AR) (IT)

(74) Representative: **Karaghiosoff, Giorgio**
Alessandro
Studio Karaghiosoff e Frizzi s.r.l.
Via Pecorile 25
17015 Celle Ligure (SV) (IT)

(56) References cited:
EP-A- 0 432 771 **US-A- 4 398 422**
US-A- 5 070 879 **US-A- 5 085 221**
US-A- 5 460 179

EP 1 681 020 B1

Note: Within nine months of the publication of the mention of the grant of the European patent in the European Patent Bulletin, any person may give notice to the European Patent Office of opposition to that patent, in accordance with the Implementing Regulations. Notice of opposition shall not be deemed to have been filed until the opposition fee has been paid. (Art. 99(1) European Patent Convention).

Description

[0001] The invention relates to an ultrasonic imaging method for 3D gynaecologic inspections, which method comprises the combination of steps according to the preamble of claim 1.

[0002] An ultrasonic imaging method as disclosed above, in combination with an ultrasound scanner for carrying out the said method and with a probe of the above mentioned kind is known from US 6,572,548 and from US.A.5460179.

[0003] This document discloses with greater details a particular 3D scanner and a particular method of producing an image from the collected received signals which can also be applied as an example in combination with the method according to this application.

[0004] The oscillation of the probe can be obtained by manually oscillating the entire probe, or in an improved manner which is also disclosed in the above mentioned document by means of a so called 3D probe in which the transducer array can be oscillated by means of a stepped electric motor around an axis of rotation which is oriented parallel or which is coincident with the longitudinal central axis of the array of transducers.

[0005] Thus the oscillation of the array of transducers can be driven by the ultrasound scanner and in a synchronised manner with the ultrasound scanning shots and the successive receipt of the reflected ultrasound echoes. Thereby the probe can be held fixed in a conventional position. 3D probes can be of several kind, such as so called linear array probes being provided with a linear array of transducers or so called convex probes which are provided with a linear array of transducers which are distributed on an arched line so to form an arched front of transducers placed side by side.

[0006] Linear arrays of transducers in which the transducers are placed side by side along a straight line generate images which are corresponding to a scanning plane perpendicular to the transducer frontal emitting and receiving surface and which dimension in the longitudinal direction of the transducers array is constant for the entire scanning depth. Thus the images obtained are essentially of a rectangular shape.

[0007] Convex linear arrays of transducers produce an image having a trapezoidal shape, the dimension of the imaged area and thus of the image obtained increasing with the depth of penetration of the scanning pulse within the target body.

[0008] When an oscillating transducer array is provided it is important that the axis of oscillation is coincident as far as possible with the longitudinal central axis of the array. This in order to reduce as far as possible vibrations to the probe due to the oscillating mass. Also the requested power for oscillating the array of transducers is reduced when the axis of oscillation is very near or coinci-

dent with the central longitudinal axis of the array.

[0009] Considering convex linear arrays, the axis of oscillation can be a secant of the array or can be coincident with a line connecting the two end of the array or even the axis of oscillation could be chosen as to be tangent to the central point of the arched linear array. Thus there are always parts of the array having a considerable radial distance from the axis of rotation inducing considerable angular momentums. Under this conditions the power needed for oscillating the arched array is bigger than in the plane rectilinear array and the probe is subjected to considerable vibrations. In addition, due to the energy law of conservations the free orientation of the probe particularly relatively to an axis of angular displacement not parallel to the axis of oscillation of the array of transducers is hindered so that the manipulation of the probe becomes more difficult or uncomfortable.

[0010] The above mechanical effect is far from being a negligible detail since it has to be considered that the oscillation is an alternative motion. So the direction of motion of the array of transducers has to reversed each time. This requests deceleration and acceleration of the mass of the transducer. Furthermore the kinetic energy is very high since the frequency of oscillation is very high, particularly when a very high frame rate is desired. According to the above the motor for driving the array of transducers has to furnish a sufficient power for rapidly stopping and accelerating the array at a certain speed and the effects of the mechanical inertia on the entire probe form the point of view of the vibrations and of the reduced handiness of the probe are considerable.

[0011] A further drawback in using a so called convex array of transducers, this is an array of transducers aligned along an arched line the emission surfaces of the transducers being placed with the axis perpendicular to the said emission surfaces oriented along the radial direction of the curved line and away from the centre of curvature, is that the trapezoidal surface covered by the convex array of transducers is very wide so that often problems arises of acoustic coupling in some areas of the said surface.

[0012] In gynaecologic imaging for example of the foetus, the width of the rectangular imaged zone obtained by a normal linear array of transducers is not sufficient in order to image the entire region, particularly at high penetration depths at which at least part of the foetus is located. A trapezoidal imaged area diverging in the direction of penetration of the emitted ultrasound beams would be more suited for the ultrasound foetal examination so that a convex probe would be the better one to be applied. Nevertheless using such a convex probe would cause the drawbacks indicated above if it is desired to carry out a 3D (three dimensional) image acquisition.

[0013] The object of the present invention is to provide for an ultrasonic imaging method for 3D gynaecologic inspections which can overcome the drawback of the actual state of the art, by allowing a wider field of view or imaged region, particularly a trapezoidal image region in

combination with an automatic oscillating array of transducers having vary limited inertial effects on the probe and reducing the problem of acoustic coupling in the marginal areas of the imaged region.

[0014] A further object of the present invention is to provide for an ultrasound probe which particularly adapted to carry out the above mentioned method.

[0015] Still another object of the present invention is to provide an ultrasound imaging system particularly suited for carrying out the above mentioned method.

[0016] The invention achieves the above mentioned aims by means of an ultrasonic imaging method for 3D gynaecologic inspections according to the preamble of claim 1 and further comprising the steps according to the characterising part of claim 1.

[0017] The steering of the ultrasound emitted beams can be obtained as known to the skilled person by providing transducers driving signals having delays in driving each transducer of the array so that the emitted ultrasound beam is laterally steered outwards of the lateral limits of the imaged area defined by the projection of the linear array of transducers in a direction perpendicular to the longitudinal extension of the said linear array.

[0018] As it is known to the skilled person each transducer of the array of transducers generates upon excitation an ultrasound pulse which propagates from the surface of the excited transducer. By exciting the different transducers of the array to emission of the corresponding ultrasound pulse at different instants it is possible to focus the beam emitted by the array of transducers which is formed by the contribution of the ultrasound pulse of each transducer along a certain line. The excitation delays among different transducers of the array defines the line and the orientation of the line along which the single pulses emitted by the single transducers constructively interfere so that a focalization on the said line is obtained.

[0019] Applying certain delays rules it is possible to focus the emitted ultrasound beam on a line which is diverging laterally outside the slice or surface defined by the projection in the direction perpendicular to it of the longitudinal extension of the array of transducers, thus covering with the emitted ultrasound beams also two triangular zones outside the typical rectangular image zone of a linear array of transducers.

[0020] Obviously in order to generate an image the same focussing rule must be applied for the reflected beams.

[0021] Thus using a linear array of transducers it is possible to virtually generate a trapezoidal image similarly to a convex array of transducers avoiding in this case the drawbacks relating to the oscillation of a convex array of transducers and the drawbacks of acoustic coupling problems of the said convex array of transducers.

[0022] Figures 1 and 2 illustrate the typical trapezoidal image area of a convex probe and of a linear probe, while figure 3 illustrates the trapezoidal image area obtained by the beam steering step provided according the method of the present invention.

[0023] As already said steering ultrasound beams in the way it is done according to the present invention is technically possible and the skilled person is aware on how to carry out steering. US 5,447,158 discloses with more detail a method of steering the ultrasound beams emitted by a linear probe in such a way as to obtain a trapezoidal scanning or image area.

[0024] Although steering of the ultrasound beams is a known technique, the actual state of the art does not consider the problem of applying steering as a solution to the problem of improving a 3D ultrasound imaging method and system in order to overcome the drawbacks of a 3D ultrasound convex probe.

[0025] According to the present invention an ultrasound probe which is particularly adapted to carry out the above mentioned method and comprises a linear array of ultrasound transducers, i.e. an array of transducers arranged side-by-side along a straight line and supported in such a manner as to swing about an axis which is parallel to said straight line along which the transducer array extends and which axis is near or passes through the center of mass of the array of transducers there being provided an electric motor which controls the oscillation of the transducer array through a drive.

[0026] The electric motor and the drive for oscillating the transducer array are housed inside a probe case.

[0027] The probe case includes a housing having an end portion which is sealed and in which end portion the linear transducer array the swing axis and the drive are housed, and a housing for accommodating and allowing the passage of the connecting wires and of the motor, the two housings being separated from each other in a liquid-tight manner and there being provided a liquid-tight passage for the connecting wires and the motor shaft from one housing to the other.

[0028] Relating to the trapezoidal scanning planes obtained by laterally steering the ultrasound beams it has to be highlighted that in the present invention the scanning on the trapezoidal scanning plane is not obtained by steering the ultrasound beams so to have inclined parallel ultrasound beams, but the trapezoidal scanning plane is covered by carrying out scanning along a number of adjacent scanning lines which are not parallel but are angularly displaced one from the other and are oriented along different angular directions relatively to a common center of angular displacement on which center fall the prolongations of the scanning line in a backward direction relatively to the propagation direction.

[0029] Furthermore the invention provides for an ultrasound imaging system particularly suited for carrying out the above mentioned method comprising in combination an ultrasound probe including a linear array of transducers which is swingable around an axis being parallel to or coincident with the longitudinal axis of the linear array of transducers and

Ultrasound image scanning means coupled to the probe for scanning a slice of the interior of a target body having a trapezoidal shape;

Ultrasound image producing means for producing image data from the reflected ultrasound scanning beams; Displaying means for displaying the image data.

[0030] The ultrasound image scanning means for scanning a slice of the interior of a target body having a trapezoidal shape comprises usually means for steering the ultrasound beam formed by the contribution of the emitted ultrasound pulse of each of the transducers of the linear array of transducers so that the surface or slice scanned by the ultrasound beam has a trapezoidal shape having an increasing width in direction of propagation of the ultrasound beams.

[0031] This steering means usually comprises means for generating a sequence of time delayed excitation pulses of the single transducers causing the transducers to emit time delayed ultrasound pulses; the time delays of the excitation pulses of each transducers being determined in such a way as to generate ultrasound beams focused on propagation directions which sweeps the trapezoidal slice.

[0032] In a conventional ultrasound imaging system, the said steering means are formed by a so called transmission beamformer which is driven by a control unit according to a selected time delay sequence of the transducers excitation pulses. This sequence can be retrieved from a time delay sequence memory.

[0033] Several time delay sequences may be stored in the memory which can be selected by selection input means.

[0034] The image producing means which produces image data out of the reflected image scanning beams comprises a receive beamformer which reconstructs the contributions of the single transducers in accordance with the time delay sequence and which feeds a so called scan converter generating the image data.

[0035] Further image processing units can be provided before feeding the image data to a monitor on which the image data is displayed as an image.

[0036] Alternatively to a so called three dimensional scan converter as the one disclosed in US 6,572,548, also a different technique can be used for generating an image resembling a three dimensional image. In this case the image data of each scanning plane are stored. Storing is carried out slice by slice each slice being defined by a scanning plane, while the stored image data of each slice or scanning plane is indexed by means of polar coordinates the origin of which being the common axis of oscillation of the scanning planes. After storing a rendering may be carried out by using the image data and after the rendering operation is carried out a conversion of the image data in Cartesian coordinates can be executed in order to print the images on a display. These operations can be carried out in order to obtain a so called three dimensional rendering in real time.

[0037] As a special case for the above mentioned method of generating a three dimensional real time rendering from the image data the method disclosed in US 6,582,372 can be used. The method disclosed in US

6,582,372 utilizes a probe in conjunction with little or no specialized 3-D software/hardware to produce images having depth cues. A control unit uses the probe to produce multiple slices of data, wherein each slice has a plurality of lines of data points. The control unit oversees the combination of data points from matched lines across the slices so as to create an image on the display giving the illusion of depth. Multiple scan slices are taken in each scan frame wherein the 3-D position of each slice is not necessarily chosen to produce a regularly spaced plane for a volume shape, as in standard 3-D/4-D imaging. Instead, the scan slices are oriented to be optimized for the generation of a 3-D image at a desired viewing angle. Rendering on a frame-by-frame basis is reduced to a simple weighted addition of the acoustic intensity samples of the lines at the same index in successive slices. Persistence is here employed to produce an image with a depth component. Persistence works by averaging weighted line data from the same scan line in successive frames, favouring the most recently scanned lines by using a higher weight in the average. In the simplest implementation, scan slices within a frame are regularly spaced in the elevation dimension, such that there is no lateral line shift from slice to slice. During rendering, the lines of each slice are weighted and added to their indexed lines in the other slices using descending weights from one end of the slice sequence to the other. The resulting 3-D image presents a viewing angle as though the viewer were directly in front of the slice and at an infinite distance. The front slice (defined to be the one with the highest weighting) is most prominent, while the slices behind the front slice are faded, which gives the cue of depth to the viewer by creating a dimming effect. A structure in the scanned medium which crosses lateral line boundaries and extends back in the elevation dimension will appear to fade back in the distance the farther it is from the front slice.

[0038] Further improvements of the invention will form the subject of the subclaims.

[0039] The characteristics of the invention and the advantages derived therefrom will appear more clearly from the following description of a non limiting embodiment, illustrated in the annexed drawings, in which:

Figure 1 is a schematic view of the trapezoidal shaped scanned slice of a so called convex probe.

Figure 2 is a schematic view of the rectangular shaped scanned slices of a linear probe.

Figure 3 is a schematic view of the trapezoidal scanned slice of a linear array probe according to the present invention.

Figures 4 and 5 are two sectional views with respect to two different perpendicular planes of a 3D linear probe type according to the present invention.

Figure 6 is a schematic block diagram of an ultrasound imaging system according to the present invention.

Figure 7 illustrates a lateral view of a convex array

of transducers and several possible positions of the axis of oscillation, highlighting the fact that for each choice some segments of the convex array have significant radial distances from the axis of oscillation. Figure 8 illustrates schematically a selector unit for choosing steering sequences of the probe in order to obtain a more or less trapezoidal scanning plane.

[0040] Figure 1 illustrates the volume V which is scanned by a so called convex array probe in which the probe 2 or only the array of transducers is oscillated around an axis A which is parallel to the axis connecting the two ends of the array 201, 202. By swinging the probe or the array of transducers a share of trapezoidal slices of the target body are scanned. The slices S have a trapezoidal shape with an arched basis.

[0041] As it appears clearly from figure 1, there are always segments of the array which will have a certain radial distance from the axis of oscillation event if the said axis passes through the centre of mass of the convex array.

[0042] Figure 7 illustrates schematically a convex array of transducers 20 and three possible axis of oscillation A, A', A''. One of which A connects the two end points 201, 202. The other A' passing through the centre of mass and the third one A'' being tangential to the central point of the array of transducers, it appears evident that for each position of the axis of oscillation there a large section of the array and thus a large number of transducers are radially displaced from the axis, thus contributing to a great mechanical inertia.

[0043] Figure 2 illustrates a condition in which a three dimensional linear transducer array is used. In this case the array is made of transducers aligned side by side on a row along a straight line. Thus the axis of oscillation A will have always the same radial distance from each part of the array or from each transducer. More precisely said the axis of oscillation passing the centre of mass of the array will pass through the centre of mass of each transducer element. Due to the limited radial dimensions of the cross section of the linear array. The volume scanned by a 3D liner array probe namely a probe or an array which is oscillated around an axis of oscillation A passing through the centre of mass of the array and parallel to the longitudinal axis of the said linear array is formed by a series of differently oriented rectangular shaped scanning planes or slices indicated by S1, S2, S3, Sn. Thus the scanned area or volume has a constant width all over the penetration depth Z in the body under examination. In figure 2 the intersection of the scanning planes is shown with an image plane P oriented in the x-z plane as defined by the Cartesian system x, y, z. The intersection lines of the scanning planes with the image plane are indicated with L1, L2, L3, Ln. The image plane can have any orientation in the three dimensional space and due to the fact that a three dimensional volume is scanned by means of the scanning planes S1 to Sn, any plane can be used in order to generate an image of the body under

examination along the chosen image plane.

[0044] Figure 3 illustrates schematically a probe 2 having a linear array 20 of transducers 120. Each transducer can be excited by an electric excitation signal separately from the other transducers to emit an ultrasound pulse. Furthermore each transducers can be excited by the reflected ultrasound beams impinging on it to generate a corresponding electric signal which is then elaborated in order to extract the information in the form of image data.

[0045] By exciting each transducer with an excitation signal having a predetermined certain delay with respect to the excitation of the preceding transducer in the array the emitted pulses of the transducers of the array interfere in such a way as to generate a beam B having a certain direction and location on the scanned slice. Thus a scanning beam can be generated which sweeps a slice having a trapezoidal form diverging in the direction of propagation of the ultrasound beams, i.e. in the direction of penetration of the scanned slice in the examined body.

[0046] Small dotted lines are the scanning lines on which the ultrasound beams are focused by so called steering. This scanning lines diverges laterally outwards from a rectangular slice defined by the projection of the linear array in a direction perpendicular to its longitudinal extension.

[0047] Analogously large dotted lines are the scanning lines on which the ultrasound beams are focused by steering the beams in the opposite direction. The axis or oscillation of the linear array of transducers is indicated by A.

[0048] It is evident that by oscillating the array of transducers to which the above mentioned steering law is applied a scanning volume can be obtained which has an intermediate shape as the one of figure 1 and of figure 2.

[0049] In figures 4 and 5 an example of a so called linear sector probe is illustrated. This probe includes a transducer array 20 for performing a two-dimensional scan, i.e. a scan following a plurality of lines, named lines of view, or beams, named sector beams, oriented parallel or substantially parallel to the probe axis and arranged side-by-side to cover a whole predetermined section plane of the object volume.

[0050] The transducer array 20 is mounted inside a housing of a support 23 at an end of the probe. The support is mounted in such a manner as to swing about an axle 24 parallel to the extension of the scan planes. The swing axle 24 is provided as near as possible to the centre of mass of the transducer array 20 and at a certain distance from the transmission surface of the transducer array. The swinging support 23 has a toothed circular sector, i.e. a circular rack 25 on the side diametrically opposite to the axle 24, which circular rack 25 cooperates with a pinion 26. The pinion 26 is rotatably driven by a stepper motor 27 through a drive consisting of a gear 28 splined to the motor shaft and of a worm 29. The transducer array is outwardly covered by a cap 30 which is connected to the rest of the probe body, formed by a case for accommodating the connecting wires 31, the stepper

motor and the drive with the pinion and the circular rack. The housing 32 for accommodating the transducer array, the support for the transducers and the circular rack, as well as the drive, is filled with an acoustic coupling liquid which is known and widely used in the art. The cap has sealing means, such as an o-ring 33, for contact with the rest of the probe body, and in the passage contained in the housing 32 for the stepper motor shaft and the connecting wires of the transducer array.

[0051] The transducers are arranged side-by-side along a line and are electronically activated by the control processor to generate an ultrasonic beam, whose focusing point is displaced, by appropriately activating the individual transducers arranged in a straight line, along a line parallel to the straight line wherein the transducers are arranged.

[0052] Hence, for each angular position of the transducer array, the plane oriented in the ultrasonic beam transmission direction and parallel to the line wherein the adjacent transducers are arranged is scanned.

[0053] This process is repeated for each of the predetermined angular positions of the transducer array, whereby a succession of scan planes is obtained which covers the whole extension of the object volume, as shown in Fig. 3. Essentially, each scan plane consists of a set of lines of view along which the transmitted ultrasonic beam is focused at a certain depth or distance from the surface of the transducers, the focusing rule remaining the same for each line of view. Each scanning line SL of the trapezoidal scanning plane T along which the ultrasound transmission beam is focused is oriented along a direction which is angularly displaced from the direction of the adjacent scanning lines by considering a common center of angular displacement at which the backwards prolongations of the scanning lines intersects and which centre lies in a backward shifted position with respect of the probe head from which the ultrasound waves are transmitted and/or received.

[0054] The position of the swing axle of the probe is chosen in such a way that the mechanical momentum and thus inertia is reduced to a minimum and that the transmission plane of the transducers 20 is maintained at a substantially identical distance between the transducers and the facing wall of the covering cap 30 at each angular position of the transducer array.

[0055] Figure 6 illustrates a simplified block diagram of a ultrasound imaging system comprising the above mentioned probe and designed for carrying out the method of the present invention.

[0056] The probe 2 is connected by means of a switch 12 respectively to a transmit beamformer 13 and to a receive beamformer 14. Furthermore the probe is connected to a motor control drive 11.

[0057] A beamformer control unit 15 generates the electric excitation signals for each transducers with a predetermined frequency pattern. This signal is fed to the Transmit beamformer together with the information relating to the time delays for generating a sequence of

time delayed excitation of the single transducers of the transducer array of the probe. This information is furnished by a memory 16 in which a series of different time delay sequences of the excitations of the single transducers of the array are stored in order to generate ultrasound beams focused along certain lines. This different time delay sequences comprises also sequences corresponding to different degrees of steering the ultrasound beams so to obtain different diverging trapezoidal scan planes. These different trapezoidal scan plane steering options can be obtained by input or selection means 17.

[0058] In figure 6 this means which can be alternatively or in combination of different type are summarized with only one box. Nevertheless these means can comprise in combination an input line for accessing the memory and storing therein time delay sequences which has been prepared in a remote system and a user friendly selector which allows the user to simply select one of the beamforming sequences of excitation of the transducers of the array corresponding to a desired trapezoidal steering of the scanning plane generated by the probe.

[0059] In figure 8 a simple selector is illustrated. A rotatable selector knob can be rotated in several angular positions, each position corresponding to the selection command of a certain sequence of excitation of the transducers of the array corresponding to a desired trapezoidal steering of the scanning plane generated by the probe among the ones stored in the memory 16. Each position is related to a scanning plane shape which is indicated by means of an icon 217. Each icon 217 can be associated to a light signal which is activated when the corresponding sequence of excitation pulses is selected. In the example four different scanning plane shapes can be selected starting from the rectangular to the maximum diverging trapezoidal shape of the scanning plane and providing two intermediate less diverging trapezoidal shapes.

[0060] Obviously the selector can have other constructive forms as the one illustrated in the example. The selection knob could be avoided by providing a slider or electronic pads. As a variant it is also possible to provide a continuous selection instead of a stepwise selection.

[0061] Returning to the system of figure 6, the received reflected ultrasound beams are transformed in electric signals by the transducer array. The switch 12 allows transmission of the received echo electric signals generated by the transducers to a receipt beamformer 14 and the signals are then sent to a image data producing chain globally indicated by 18 and these data are finally visualized on a monitor or/and stored on a storage media. The image data producing chain 18 is well known to the skilled person and is not the object of the present invention. Normally it comprises a so called scan converter and one or more software/Hardware image processing sections for optimising the feature extraction or highlighting from the image data. In the present case since the probe is a three dimensional scanning probe in the form of a so called linear array sector probe the scan converter

is a 3D scan converter and for example a 3D scan converter according to US 6,572,548.

During an image acquisition session the stepped motor of the probe allows to collect image data along each one of several scanning planes so to cover an entire three dimensional region of interest within the body in examination. Although a linear array probe is used the scanning plane are essentially of the form according the ones generated by the convex array of figure 1. This image data can be acquired by the linear array sector probe avoiding the disadvantages of a convex array sector probe.

[0062] By providing input or selection means which enable the user to define the trapezoidal shape and/or the dimensions of this trapezoidal shape of the scanning plane two options are possible. Referring to the above describe method which can be carried out with a selector as illustrated in fig. 8 the method provides the steps of:

generating at least two or more different sequences of time delayed excitation pulses of the transducers of the linear array of transducers each of the said sequences corresponding to a differently steered ultrasound beams and to different trapezoidal shapes; selecting one of the said generated sequences of time delayed excitation pulses according to one preferred shape and/or dimension of the trapezoidal scanning plane;

applying the selected sequence of time delayed excitation pulses to the transducer for at least part or all of the scanning planes having different angular orientations.

[0063] Alternatively or in combination a continuous variation of the shape and or of the dimensions of the scanning plane can be obtained by an algorithm for generating different sequences of time delayed excitation pulses of the transducers of the linear array of transducers as a function of the geometrical parameters of the shape and/or of the dimension the trapezoidal scanning plane. In this case the input means allow to input the said parameters of shape and dimension of the scanning plane according to a continuous scale of value of the said parameters and the algorithm or the program is carried out in the beamformer control unit generating the sequence of time delayed excitation pulses of the single transducers that leads to the desired shape and dimension of the scanning plane.

[0064] Although the example describe is directed to a a so called B-mode imaging mode it appears clear that the present method probe and system can be used in combination with other kinds of existing and widely used ultrasound imaging modes such as for example harmonic imaging, pulse inversion or other known ultrasound imaging modes.

[0065] According to a further improvement of the present invention, the image data relatively to each scanning plane are stored by identifying the said data by means of the index of angular displacement of the said

scanning plane with reference to the other scanning planes. A further index indicate the scanning line within the said scanning plane. A correlation of scanning lines between the different scanning planes can be provided in order to generate an image form a weighted linear combination of the image data obtained along each of the said correlated scanning lines of the different scanning planes. Rendering of this weighted linear combination allows to generate rendering images simulating a three dimensional effect due to the consideration in the image of the weighted image data of the correlated scanning lines in the other scanning planes. The resulting 3-D image presents a viewing angle as though the viewer were directly in front of the slice and at an infinite distance. The front slice (defined to be the one with the highest weighting) is most prominent, while the slices behind the front slice are faded, which gives the cue of depth to the viewer by creating a dimming effect. A structure in the scanned medium which crosses lateral line boundaries and extends back in the elevation dimension will appear to fade back in the distance the farther it is from the front slice. Because the simple rendered view in accordance with the present invention is an orthographic projection, it does not include any scaling for depth perspective. That is, structures further from the front slice will not be scaled smaller as they would be in a real 3-D view. Because of this distortion, the total depth and thus the total number of slices should be limited so that the image has a high width-to-depth ratio. This has been referred to as a "clam-shell" 3-D image. In a typical 3-D ultrasound scan, even rendered with perspective and arbitrary views, a limited amount of depth information can be recognized and processed by the mind of the user. Accordingly, images presented in accordance with the present invention may provide just as much recognizable depth component as fully rendered 3-D images.

[0066] This kind of rendering can be done in real time and frame by frame. Considering also time in the rendering a so called four dimensional image can be printed on the monitor, meaning a three dimensional time varying image.

Claims

1. Ultrasonic imaging method particularly for 3D gynaecologic inspections, which method comprises the following steps:

Providing a linear ultrasound probe (2) comprising a certain number of transducers (120) which are placed side by side along a line forming a so called linear array (20);

Providing a B-mode imaging scanning unit to which the transducers are connected and which scanning unit alternatively generates electric driving signals for each transducer of the probe for exciting the transducers to emit ultrasound

transmission signals and receives the electric signals generated by each transducer due to the excitation of the transducers by the ultrasound signals reflect from a target body against which the ultrasound transmission signals has been emitted;

Defining a starting orientation of the direction of propagation of the ultrasound transmission signals and of the ultrasound reflected signals along which a first scanning step is carried out; Carrying out the first scanning step consisting in emitting the ultrasound transmission signals and receiving the ultrasound reflection signals along the said starting direction of propagation; Oscillating the probe in a direction transversal to the longitudinal extension of the linear array of transducers and around an axis coinciding or parallel to the said longitudinal extensions or coinciding or parallel to the central longitudinal axis of the linear array of transducers for modifying the orientation of the said direction of propagation of the ultrasound transmission signals and of the ultrasound reflected signals; Carrying out a scanning step along each new oriented direction of propagation corresponding to a different oscillation angle of the probe; Providing a 3D scan-converter in which the received signals relating to the ultrasound reflected signals are stored; Providing B-mode image producing means for generating an image from the said received signals relating to the ultrasound reflected signals are stored.

Characterised by the following further steps of Steering the ultrasound emitted beams so that the linear array of transducers generates a trapezoidal scanning slice or plane diverging in the direction of propagation of the beam;

And providing a reflected beam signals focussing rule which generates a trapezoidal image corresponding to the steered ultrasound beams.

2. A method according to claim 1, **characterised in that** the steering of the ultrasound emitted beams is obtained by providing transducers driving signals having time delays in driving each transducer of the array so that the emitted ultrasound beam is focussed on a laterally inclined propagation line deviated outwards from the lateral limits of the imaged area defined by the projection of the linear array of transducers in a direction perpendicular to the longitudinal extension of the said linear array.
3. A method according to claim 1 or 2, **characterised in that** it provides the following steps:

generating at least two or more different se-

quences of time delayed excitation pulses of the transducers of the linear array of transducers each of the said sequences corresponding to a differently steered ultrasound beams and to different trapezoidal shapes;

selecting one of the said generated sequences of time delayed excitation pulses according to one preferred shape and/or dimension of the trapezoidal scanning plane;

applying the selected sequence of time delayed excitation pulses to the transducer for at least part or all of the scanning planes having different angular orientations.

4. A method according to claim 1 or 2, **characterised in that** there is provided an algorithm for generating different sequences of time delayed excitation pulses of the transducers of the linear array of transducers as a function of the geometrical parameters of the shape and/or of the dimension the trapezoidal scanning plane and means for inputting the said parameters of shape and dimension of the scanning plane according to a continuous scale of value of the said parameters.
5. A method according to one or more of the preceding claims, **characterised in that** alternatively or in combination different ultrasound imaging modes such as harmonic imaging, pulse inversion imaging are applied for extracting the image data from the reflected ultrasound beams.
6. An ultrasound probe for carrying out the method according to one or more of the preceding claims **characterised in that** it comprises a linear array (20) of ultrasound transducers (120), i.e. an array of transducers arranged side-by-side along a straight line and supported in such a manner as to swing about an axis (A) which is parallel to said straight line along which the transducer array extends and which axis is near or passes through the center of mass of the array of transducers (20) there being provided an electric motor which controls the oscillation of the transducer array through a drive.
7. An ultrasound probe according to claim 6, **characterized in that** the electric motor and the drive for oscillating the transducer array are housed inside a probe case.
8. An ultrasound probe according to claim 6 or 7, **characterized in that** the probe case includes a housing having an end portion which is sealed and in which end portion, the linear transducer array the swing axis and the drive are housed, and a housing for accommodating and allowing the passage of the connecting wires and of the motor, the two housings being separated from each other in a liquid-tight

manner and there being provided a liquid-tight passage for the connecting wires and the motor shaft from one housing to the other.

9. An ultrasound imaging system particularly suited for carrying out the above mentioned method comprising in combination an ultrasound probe (2) including a linear array (20) of transducers (120) which is swingable around an axis (A) being parallel to or coincident with the longitudinal axis of the linear array of transducers and
 5
 10
 Ultrasound image scanning means (11, 12, 12, 14, 15, 16, 17) coupled to the probe (2) for scanning a slice (S) of the interior of a target body having a trapezoidal shape;
 Ultrasound image producing (18) means for producing image data from the reflected ultrasound scanning beams;
 Displaying means (19) for displaying the image data, **characterised in that** the ultrasound image scanning means for scanning a slice of the interior of a target body having a trapezoidal shape comprises means (13, 15, 16, 17) for steering the ultrasound beam formed by the contribution of the emitted ultrasound pulse of each of the transducers of the linear array of transducers so that the surface or slice scanned by the ultrasound beam has a trapezoidal shape having an increasing width in direction of propagation of the ultrasound beams.
10. An ultrasound imaging system according to claim 9, **characterised in that** the means for steering the ultrasound beam comprise means for generating a sequence of time delayed excitation pulses of the single transducers causing the transducers to emit time delayed ultrasound pulses;
 the time delays of the excitation pulses of each transducers being determined in such a way as to generate ultrasound beams focused on propagation directions which sweeps the trapezoidal slice.
11. An ultrasound imaging system according to claim 9 comprising a transmission beamformer (13) connected to the transducers of the probe by means of a switch (12), a beamformer control unit (15) for driving the transmission beamformer (13), the said beamformer control unit (15) being connected to a memory (16) in which at least two or more sequences of differently time delayed excitations pulses of the transducers are stored or in which an algorithm or program for generating different sequences of differently time delayed excitation pulses of the transducers as a function of geometric parameters of shape or dimensions of the scanning plane is stored, input means being provided for selecting one of the different sequences of differently time delayed excitation pulses of the transducers or for inputting shape and/or dimension parameters for the scanning

plane.

12. An ultrasound imaging system according to one or more of the preceding claims 9 to 11, **characterised in that** the image producing means which produces image data out of the reflected image scanning beams comprises a receive beamformer (14) which reconstructs the contributions of the single transducers in accordance with the time delay sequence and which feeds a so called scan converter generating the image data.
13. An ultrasound imaging system according to claim 12, **characterised in that** a chain (18) of image processing units is provided generating the image data fed to a monitor (19) on which the image data is displayed as an image.

20 Patentansprüche

1. Verfahren zur Ultraschallbildgebung, insbesondere für gynäkologische 3D-Untersuchungen, wobei das Verfahren die nachfolgenden Schritte umfasst:

Bereitstellen einer linearen Ultraschallsonde (2), umfassend eine bestimmte Anzahl von Signalgebern (120), die Seite-an-Seite entlang einer Linie angeordnet sind und somit eine sogenannte lineare Anordnung (20) bilden;
 Bereitstellen einer Abbildungsabtasteinheit vom B-Modus, mit der die Signalgeber verbunden sind, und wobei die Abtasteinheit alternativ elektrische Ansteuersignale für jeden Signalgeber der Sonde zum Auslösen der Signalgeber erzeugt, um Ultraschallübertragungssignale zu emittieren, und die elektrischen Signale empfängt, die durch jeden Signalgeber erzeugt werden, aufgrund der Anregung der Signalgeber durch Ultraschallsignale, die von einem Zielkörper, gegen den die Ultraschallübertragungssignale ausgesandt wurden, reflektiert werden;
 Definieren einer Ausgangsorientierung der Richtung der Ausbreitung der Ultraschallübertragungssignale und der Ultraschallreflektionssignale, entlang der ein erster Abtastungsschritt durchgeführt wird;
 Durchführen des ersten Abtastungsschritts, bestehend aus dem Aussenden der Ultraschallübertragungssignale und Empfangen der Ultraschallreflektionssignale entlang der Ausgangsrichtung der Ausbreitung;
 Oszillation der Sonde in einer Richtung quer zur longitudinalen Ausdehnung der linearen Anordnung der Signalgeber und um eine Achse, die mit der longitudinalen Ausdehnung zusammenfällt oder parallel zu ihr ist oder mit der zentralen longitudinalen Achse der linearen Anordnung

der Signalgeber zur Modifizierung der Orientierung der Richtung der Ausbreitung der Ultraschallübertragungssignale und der reflektierten Ultraschallsignale zusammenfällt oder parallel zu ihr ist;

Durchführen eines Abtastungsschritts entlang jeder neuen eingenommenen Ausbreitungsrichtung, entsprechend einem unterschiedlichen Oszillationswinkel der Sonde;

Bereitstellen eines 3D-Abtastumwandlers, in dem die empfangenen Signale, die den reflektierten Ultraschallsignalen entsprechen, gespeichert werden;

Bereitstellen von Bilderzeugungsmitteln vom B-Modus zur Erzeugung eines Bildes aus den empfangenen Signalen, entsprechend den gespeicherten reflektierten Ultraschallsignalen; charakterisiert durch die nachfolgenden weiteren Schritte:

Steuern der emittierten Ultraschallwellen, so dass die lineare Anordnung der Signalgeber einen trapezförmigen Abtastschlitz oder eine trapezförmige Abtastebene erzeugen, die in Richtung der Ausbreitung des Strahls divergiert;

und Bereitstellen einer Fokussierungsregel der reflektierten Strahlsignale, die ein trapezförmiges Bild erzeugt, entsprechend den gesteuerten Ultraschallwellen.

2. Verfahren nach Anspruch 1, **dadurch gekennzeichnet, dass** das Steuern der emittierten Ultraschallwellen erhalten wird durch das Bereitstellen von Signalgeberansteuersignalen mit Zeitverzögerungen beim Ansteuern jedes Signalgebers der Anordnung, so dass der emittierte Ultraschallstrahl auf einer lateral geneigten Ausbreitungslinie fokussiert wird, die nach außen von den lateralen Begrenzungen des abgebildeten Bildes abweicht, das durch die Projektion der linearen Anordnung von Signalgebern in einer Richtung, senkrecht zur longitudinalen Ausdehnung der linearen Anordnung definiert ist.

3. Verfahren nach Anspruch 1 oder 2, **dadurch gekennzeichnet, dass** dieses die nachfolgenden Schritte bereitstellt:

Erzeugen von mindestens zwei oder mehr verschiedenen Zeitsequenzen mit verzögerten Anregungspulsen der Signalgeber der linearen Anordnung von Signalgebern, wobei jede der Sequenzen einem unterschiedlich gesteuerten Ultraschallstrahl und verschiedenen trapezförmigen Formen entspricht;

Auswählen einer der erzeugten Zeitsequenzen mit verzögerten Anregungspulsen gemäß einer bevorzugten Form und/oder Dimension der tra-

pezförmigen Abtastebene;

Einsetzen der ausgewählten Zeitsequenz mit verzögerten Anregungsimpulsen an den Signalgeber für mindestens einen Teil oder sämtliche der Abtastebenen mit verschiedenen Winkelorientierungen.

4. Verfahren nach Anspruch 1 oder 2, **dadurch gekennzeichnet, dass** ein Algorithmus zur Erzeugung verschiedener Zeitsequenzen mit verzögerten Anregungsimpulsen der Signalgeber der linearen Anordnung von Signalgebern als eine Funktion der geometrischen Parameter der Form und/oder der Dimension der trapezförmigen Abtastebene bereitgestellt wird, und Mittel zum Eingeben der Parameter der Form und Dimension der Abtastebene gemäß einem kontinuierlichen Wertemaßstab der Parameter.

5. Verfahren nach einem oder mehreren der vorangehenden Ansprüche, **dadurch gekennzeichnet, dass** alternativ oder in Kombination verschiedene Ultraschallabbildungsmoden wie harmonische Abbildung, Pulsinversionsabbildung zur Extraktion der Bilddaten aus den reflektierten Ultraschallwellen eingesetzt werden.

6. Ultraschallsonde zum Durchführen des Verfahrens nach einem oder mehreren der vorangehenden Ansprüche, **dadurch gekennzeichnet, dass** diese eine lineare Anordnung (20) von Ultraschallsignalgebern (120) aufweist, d.h. eine Anordnung von Signalgebern, angeordnet Seite-an-Seite entlang einer geraden Linie und in einer derartigen Art und Weise getragen, dass diese um eine Achse (A) schwingen, die parallel zur geraden Linie verläuft, entlang der sich die Signalgeberanordnung erstreckt, und die Achse nahe dem Zentrum der Masse der Anordnung von Signalgebern (20) liegt oder durch diese hindurchgeht, und durch Bereitstellen eines elektrischen Motors, der die Oszillation der Signalgeberanordnung durch einen Antrieb steuert.

7. Ultraschallsonde nach Anspruch 6, **dadurch gekennzeichnet, dass** der elektrische Motor und der Antrieb zur Oszillation der Signalgeberanordnung in einem Sondengehäuse untergebracht sind.

8. Ultraschallsonde nach Anspruch 6 oder 7, **dadurch gekennzeichnet, dass** das Sondengehäuse ein Gehäuse mit einem Endabschnitt umfasst, das abgedichtet ist und in dem Endabschnitt die lineare Signalgeberanordnung, die Schwingachse und der Antrieb untergebracht sind, und ein Gehäuse zum Unterbringen und Ermöglichen der Passage der Verbindungsleitungen und des Motors, wobei die zwei Gehäuse voneinander in flüssigkeitsdichter Art und Weise getrennt sind, und eine flüssigkeitsdichte

Passage für die Verbindungsleitungen und den Motorschaft von einem Gehäuse zum anderen bereitgestellt ist.

9. System zur Ultraschallbildgebung, insbesondere geeignet zur Durchführung des oben erwähnten Verfahrens, umfassend in Kombination eine Ultraschallsonde (2), enthaltend eine lineare Anordnung (20) von Signalgebern (120), die schwingbar um eine Achse (A), parallel oder zusammenfallend mit der longitudinalen Achse der linearen Anordnung von Signalgebern, vorliegt, und
 5
 10
 15
 20
 25
 30
 35
 40
 45
 50
 55
- Ultraschallbildabtastmitteln (11, 12, 12, 14, 15, 16, 17), gekoppelt mit der Sonde (2), zum Abtasten eines Schnitts (S) des Inneren eines Zielkörpers mit einer trapezförmigen Formung;
 Ultraschallbilderzeugungsmittel (18) zum Erzeugen von Bilddaten der reflektierten Ultraschallab tastwellen;
 Anzeigemittel (19) zum Anzeigen der Bilddaten, **dadurch gekennzeichnet, dass** die Ultraschall bildabtastmittel zum Abtasten eines Schnitts des Inneren eines Zielkörpers mit einer trapezförmigen Form umfassen: Mittel (13, 15, 16, 17) zum Steuern des Ultraschallstrahls, gebildet durch den Beitrag des emittierten Ultraschallpulses von jedem der Signalgeber der linearen Anordnung von Signalgebern, so dass die Oberfläche oder der Schnitt, der durch den Ultraschallstrahl abgetastet wird, eine trapezförmige Form mit einer zunehmenden Breite in Richtung der Ausbreitung der Ultraschallwellen aufweist.
10. Ultraschallbildgebungssystem nach Anspruch 9, **dadurch gekennzeichnet, dass** die Mittel zum Steuern des Ultraschallstrahls Mittel zum Erzeugen einer Zeitsequenz mit verzögerten Erregungspulsen der einzelnen Signalgeber umfasst, welche bewirken, dass Signalgeber zeitversetzte Ultraschallpulse emittieren;
 wobei die Zeitverzögerungen der Anregungspulse jedes Signalgebers in einer derartigen Art und Weise bestimmt werden, dass Ultraschallwellen erzeugt werden, die auf die Ausbreitungsrichtungen fokussieren, die den trapezförmigen Schnitt abtasten.
11. System zur Ultraschallbildgebung nach Anspruch 9, umfassend einen Transmissionsstrahlformer (13), verbunden mit den Signalgebern der Sonde mittels eines Schalters (12), eine Strahlformkontrolleinheit (15) zum Antreiben des Transmissionsstrahlformers (13), wobei die Strahlformkontrolleinheit (15) mit einem Speicher (16) verbunden ist, in dem mindestens zwei oder mehr Sequenzen verschiedener zeitverzögerter Anregungspulse der Signalgeber gespeichert sind oder in der ein Algorithmus oder ein Programm zur Erzeugung verschiedener Sequenzen für verschiedene zeitverzögerte Anregungspulse der

Signalgeber als Funktion geometrischer Parameter der Form oder Dimension der Abtastebene gespeichert sind, Eingabemittel bereitgestellt sind zur Auswahl einer der verschiedenen Sequenzen verschiedener zeitverzögerter Anregungspulse der Signalgeber oder zum Eingeben von Form- und/oder Dimensionsparametern für die Abtastebene.

12. System zur Ultraschallbildgebung nach einem oder mehreren der vorangehenden Ansprüche 9 bis 11, **dadurch gekennzeichnet, dass** die Bilderzeugungsmittel, die Bilddaten aus den reflektierten Bildabtaststrahlen erzeugen, umfassen: einen Empfangsstrahlformer (14), der die Beiträge der einzelnen Signalgeber gemäß der zeitverzögerten Sequenz rekonstruiert und der einen sogenannten Ab tastumwandler speist, der Bilddaten erzeugt.
13. System zur Ultraschallbildgebung nach Anspruch 12, **dadurch gekennzeichnet, dass** eine Kette (18) von Bildverarbeitungseinheiten bereitgestellt wird, und die Bilddaten erzeugt, die zu einem Monitor (19) gespeist werden, auf dem die Bilddaten als Bild gezeigt werden.

Revendications

1. Procédé d'imagerie par ultrasons, en particulier d'examens gynécologiques en 3D, lequel procédé comprend les étapes suivantes consistant à :
- fournir une sonde à ultrasons linéaire (2) comprenant un certain nombre de transducteurs (120) qui sont placés côte à côte le long d'une ligne, en formant ce qu'il est convenu d'appeler un réseau linéaire (20) ;
 fournir une unité de balayage d'imagerie en mode B à laquelle les transducteurs sont connectés, laquelle unité de balayage génère en outre des signaux de commande électriques de chaque transducteur de la sonde excitant les transducteurs pour émettre des signaux de transmission ultrasonores, et reçoit les signaux électriques générés par chaque transducteur dus à l'excitation des transducteurs par une réflexion des signaux ultrasonores par un corps cible vers lequel les signaux de transmission ultrasonores ont été émis ;
 définir une orientation initiale de la direction de propagation des signaux de transmission ultrasonores et des signaux ultrasonores réfléchis le long de laquelle une première étape de balayage est effectuée ;
 exécuter la première étape de balayage consistant à émettre les signaux de transmission ultrasonores et à recevoir les signaux de réflexion ultrasonores le long de ladite direction de pro-

pagation initiale ;
 faire osciller la sonde dans une direction transversale à la direction longitudinale du réseau linéaire de transducteurs et autour d'un axe qui coïncide ou qui est parallèle à ladite direction longitudinale, ou qui coïncide ou qui est parallèle à l'axe longitudinal central du réseau linéaire de transducteurs modifiant l'orientation de ladite direction de propagation des signaux de transmission ultrasonores et des signaux réfléchis ultrasonores ;
 exécuter une étape de balayage le long de chaque nouvelle direction de propagation orientée correspondant à un angle d'oscillation différent de la sonde ;
 fournir un convertisseur de balayage en 3D dans lequel sont stockés les signaux reçus concernant les signaux ultrasonores réfléchis ;
 fournir des moyens de production d'une image en mode B générant une image à partir desdits signaux reçus concernant les signaux ultrasonores réfléchis qui sont stockés,

caractérisé par les étapes supplémentaires suivantes consistant à :

guider les faisceaux ultrasonores émis de telle sorte que le réseau linéaire de transducteurs génère une tranche ou un plan de balayage trapézoïdal qui diverge dans la direction de propagation du faisceau ;
 et à fournir une règle de focalisation des signaux de faisceau réfléchis, qui génère une image trapézoïdale correspondant aux faisceaux ultrasonores guidés.

2. Procédé selon la revendication 1, **caractérisé en ce que** le guidage des faisceaux ultrasonores émis est obtenu en fournissant des signaux de commande de transducteurs présentant des retards dans la commande de chaque transducteur du réseau de telle sorte que le faisceau ultrasonore émis soit focalisé sur une ligne de propagation inclinée latéralement et déviée vers l'extérieur à partir des limites latérales de la zone imagée définie par la projection du réseau linéaire de transducteurs dans une direction perpendiculaire à la direction longitudinale dudit réseau linéaire.
3. Procédé selon la revendication 1 ou la revendication 2, **caractérisé en ce qu'il** prévoit les étapes suivantes consistant à :
 générer au moins deux ou plusieurs séquences différentes d'impulsions d'excitation retardées dans le temps des transducteurs du réseau linéaire de transducteurs, chacune desdites séquences correspondant à des faisceaux ultra-

sonores guidés différemment et à des formes trapézoïdales différentes ;
 sélectionner l'une desdites séquences d'impulsions d'excitation retardées dans le temps générées selon une forme et/ou des dimensions préférées du plan de balayage trapézoïdal ;
 appliquer la séquence sélectionnée d'impulsions d'excitation retardées dans le temps aux transducteurs pour au moins une partie, voire la totalité, des plans de balayage ayant différentes orientations angulaires.

4. Procédé selon la revendication 1 ou la revendication 2, **caractérisé en ce qu'il** est fourni un algorithme de génération des différentes séquences d'impulsions d'excitation retardées dans le temps des transducteurs du réseau linéaire de transducteurs, en fonction des paramètres géométriques de la forme et/ou des dimensions du plan de balayage trapézoïdal, et des moyens d'introduction desdits paramètres de forme et de dimensions du plan de balayage selon une échelle continue de valeurs desdits paramètres.
5. Procédé selon une ou plusieurs des revendications précédentes, **caractérisé en ce que**, en variante ou en combinaison, différents modes d'imagerie par ultrasons tels qu'une imagerie harmonique, une imagerie en inversion d'impulsion, sont appliqués, extrayant les données d'image à partir des faisceaux ultrasonores réfléchis.
6. Sonde à ultrasons pour mettre en oeuvre le procédé selon une ou plusieurs des revendications précédentes, **caractérisée en ce qu'elle** comprend un réseau linéaire (20) de transducteurs à ultrasons (120), c'est-à-dire un réseau de transducteurs disposés côte à côte le long d'une ligne droite et supportés de façon à osciller autour d'un axe (A) qui est parallèle à ladite ligne droite le long de laquelle le réseau de transducteurs s'étend, lequel axe est proche du, ou passe par le, centre de gravité du réseau de transducteurs (20), un moteur électrique étant fourni de manière à commander l'oscillation du réseau de transducteurs par l'intermédiaire d'une commande.
7. Sonde à ultrasons selon la revendication 6, **caractérisée en ce que** le moteur électrique et la commande faisant osciller le réseau de transducteurs sont logés à l'intérieur d'un boîtier de sonde.
8. Sonde à ultrasons selon la revendication 6 ou la revendication 7, **caractérisé en ce que** le boîtier de sonde inclut un logement ayant une extrémité qui est scellée, extrémité dans laquelle sont logés le réseau linéaire de transducteurs, l'axe d'oscillation et la commande, et un logement recevant et permettant

le passage des fils de connexion et du moteur, les deux logements étant séparés l'un de l'autre d'une façon étanche aux liquides, un passage étanche aux liquides étant prévu, d'un logement à l'autre, pour les fils de connexion et l'arbre du moteur.

9. Système d'imagerie par ultrasons particulièrement adapté à la mise en oeuvre du procédé mentionné ci-dessus comprenant en combinaison une sonde à ultrasons (2) incluant un réseau linéaire (20) de transducteurs (120) qui peut osciller autour d'un axe (A) parallèle à, ou qui coïncide avec, l'axe longitudinal du réseau linéaire de transducteurs, et des moyens de balayage d'image par ultrasons (11, 12, 13, 14, 15, 16, 17) couplés à la sonde (2) balayant une tranche (S) de l'intérieur d'un corps cible, présentant une forme trapézoïdale ;

des moyens de production (18) d'image par ultrasons produisant des données d'images à partir des faisceaux de balayage par ultrasons réfléchis ; des moyens d'affichage (19) affichant les données d'image,

caractérisé en ce que les moyens de balayage d'image par ultrasons balayant une tranche de l'intérieur d'un corps cible, présentant une forme trapézoïdale, comprennent des moyens (13, 15, 16, 17) de guidage du faisceau d'ultrasons formé par la contribution des impulsions ultrasonores émises de chacun des transducteurs du réseau linéaire de transducteurs, de telle sorte que la surface ou la tranche balayée par le faisceau d'ultrasons ait une forme trapézoïdale qui présente une largeur allant en croissant dans la direction de propagation des faisceaux d'ultrasons.

10. Système d'imagerie par ultrasons selon la revendication 9, **caractérisé en ce que** les moyens de guidage du faisceau d'ultrasons comprennent des moyens de génération d'une séquence d'impulsions d'excitation retardées dans le temps des capteurs unitaires provoquant l'émission, par les transducteurs, d'impulsions ultrasonores retardées dans le temps ;

les retards temporels des impulsions d'excitation de chacun des transducteurs étant déterminés de façon à générer des faisceaux d'ultrasons focalisés dans des directions de propagation qui balaient la tranche trapézoïdale.

11. Système d'imagerie par ultrasons selon la revendication 9, comprenant un dispositif de formation de faisceau de transmission (13) connecté aux transducteurs de la sonde à l'aide d'un commutateur (12), une unité de commande de dispositif de formation de faisceau (15) commandant le dispositif de formation de faisceau de transmission (13), ladite unité de commande de dispositif de formation de faisceau (15) étant connectée à une mémoire (16) dans la-

quelle sont stockées au moins deux séquences, ou plus, d'impulsions d'excitation retardées dans le temps de manière différente de transducteurs, ou dans laquelle est stocké un algorithme ou un programme de génération des différentes séquences d'impulsions d'excitation retardées dans le temps de manière différente, en fonction des paramètres géométriques de forme ou de dimensions du plan de balayage, des moyens d'entrée étant prévus sélectionnant l'une des différentes séquences d'impulsions d'excitation retardées dans le temps de manière différente des transducteurs, ou permettant d'entrer des paramètres de forme et/ou de dimensions du plan de balayage.

12. Système d'imagerie par ultrasons selon une ou plusieurs des revendications précédentes 9 à 11, **caractérisé en ce que** les moyens de production d'image qui produisent des données d'image à partir des faisceaux de balayage d'image réfléchis, comprennent un dispositif de formation de faisceau de réception (14) qui reconstruit les contributions des capteurs individuels selon la séquence de retard temporel et qui fournit ce qu'il est convenu d'appeler un convertisseur de balayage qui génère les données d'image.

13. Système d'imagerie par ultrasons selon la revendication 12, **caractérisé en ce qu'il** est fourni une chaîne (18) d'unités de traitement d'image générant les données d'image transmises à un moniteur (19) sur lequel les données d'image sont affichées sous la forme d'une image.

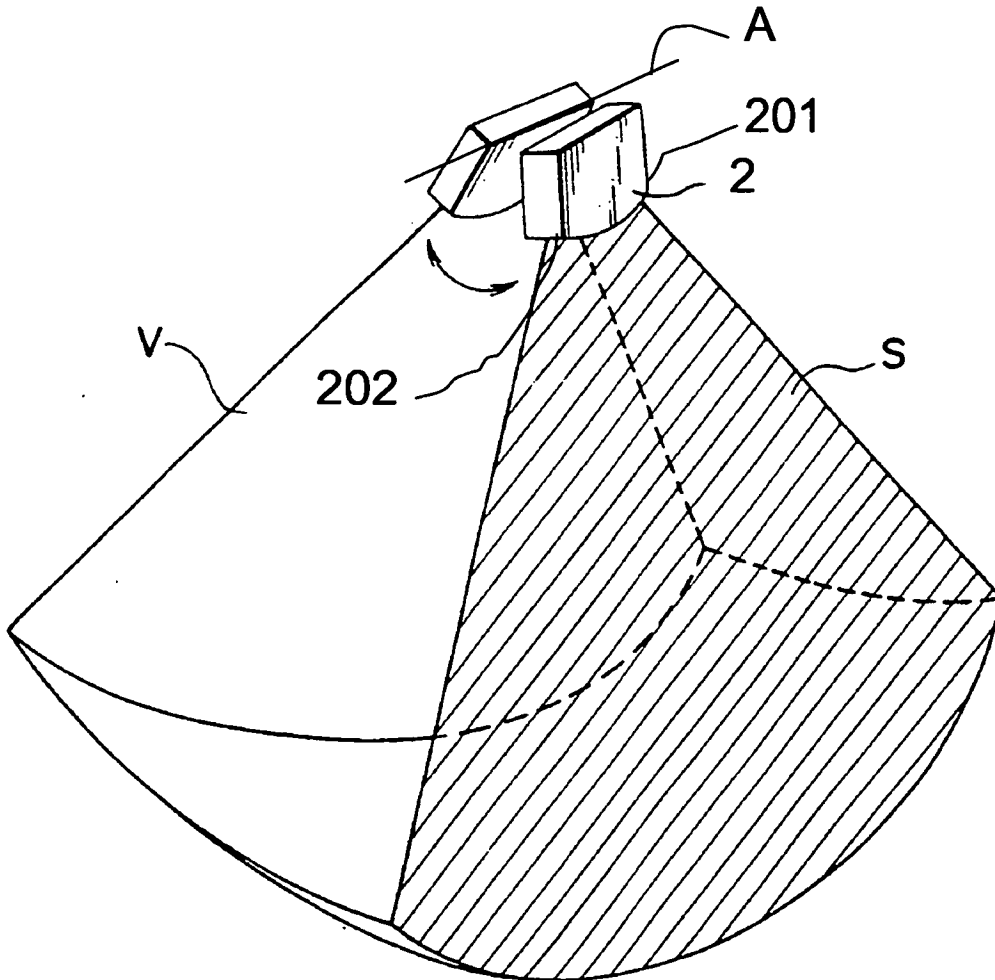

Fig. 1

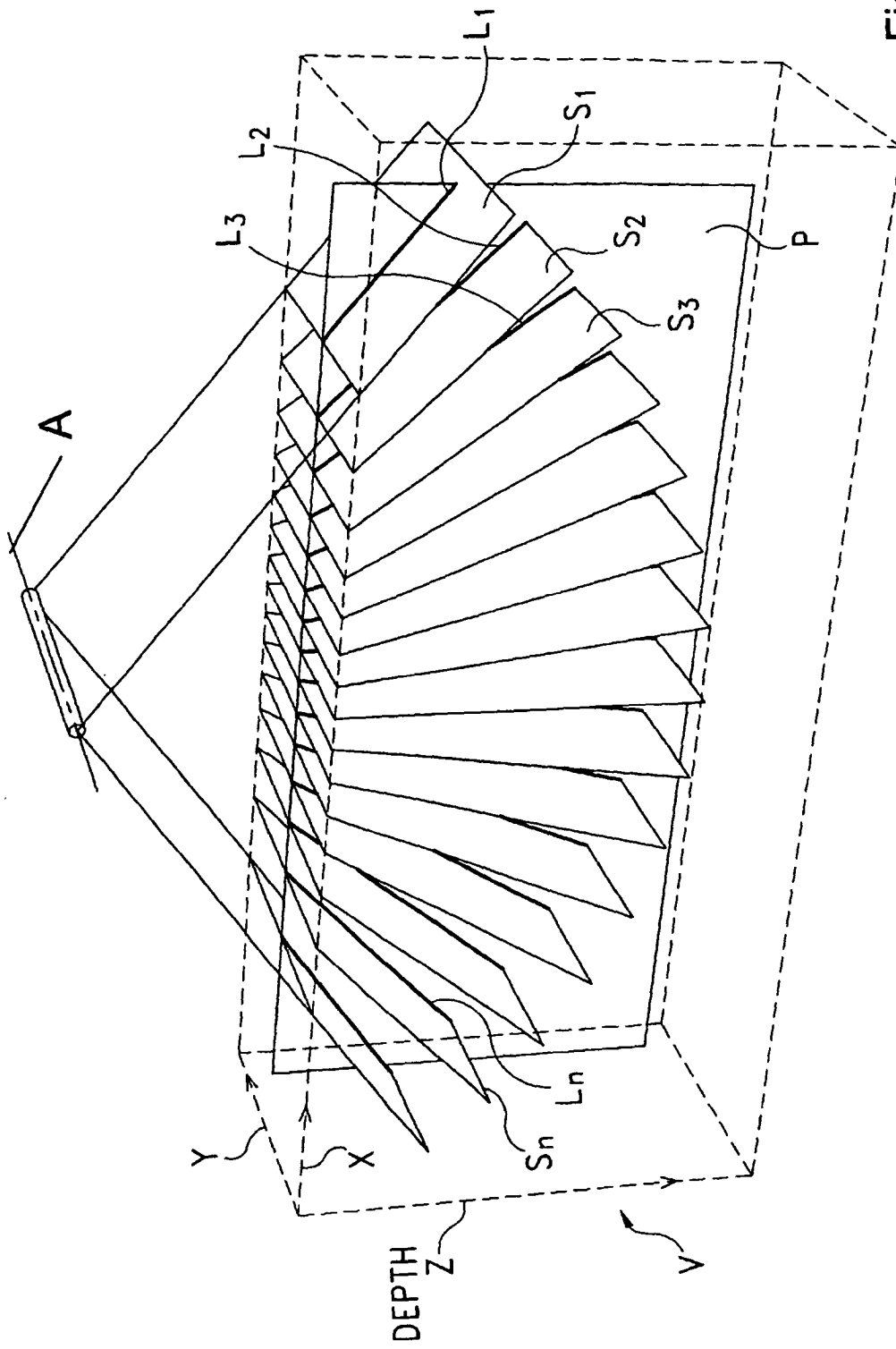

Fig. 2

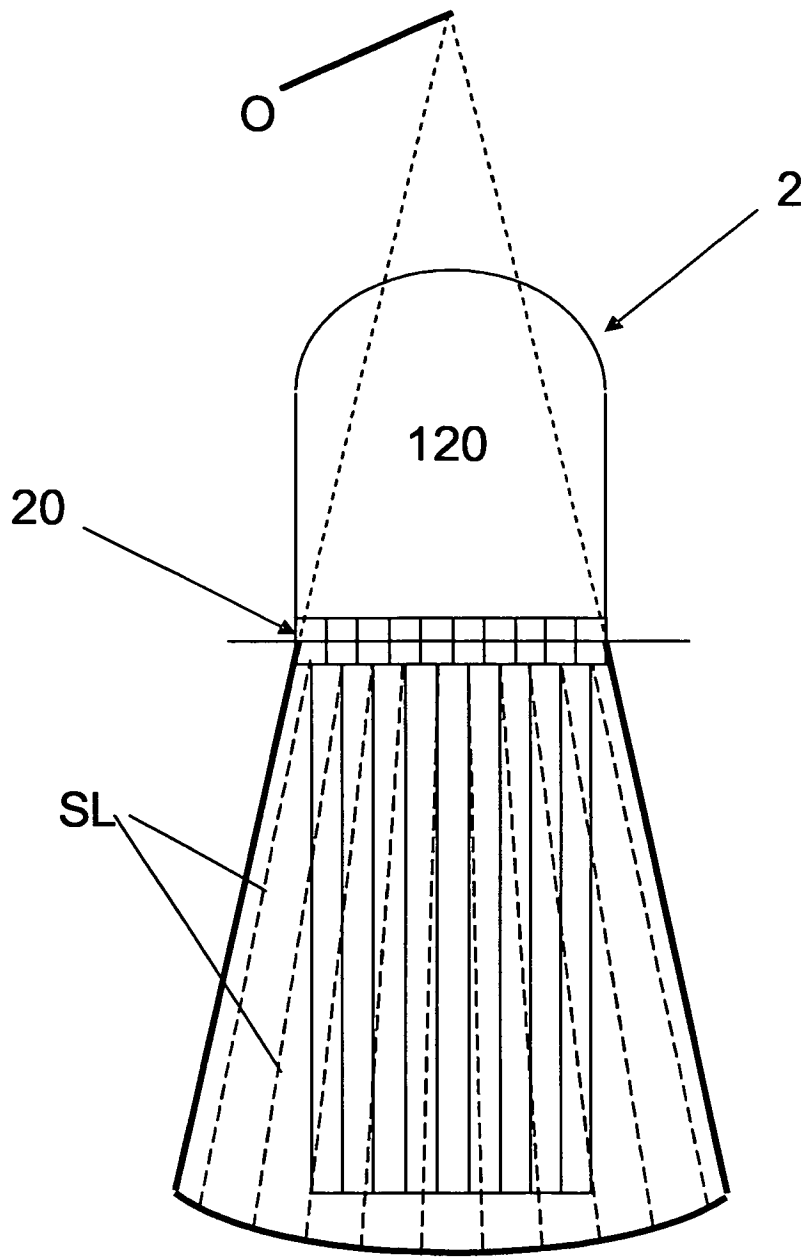

Fig. 3

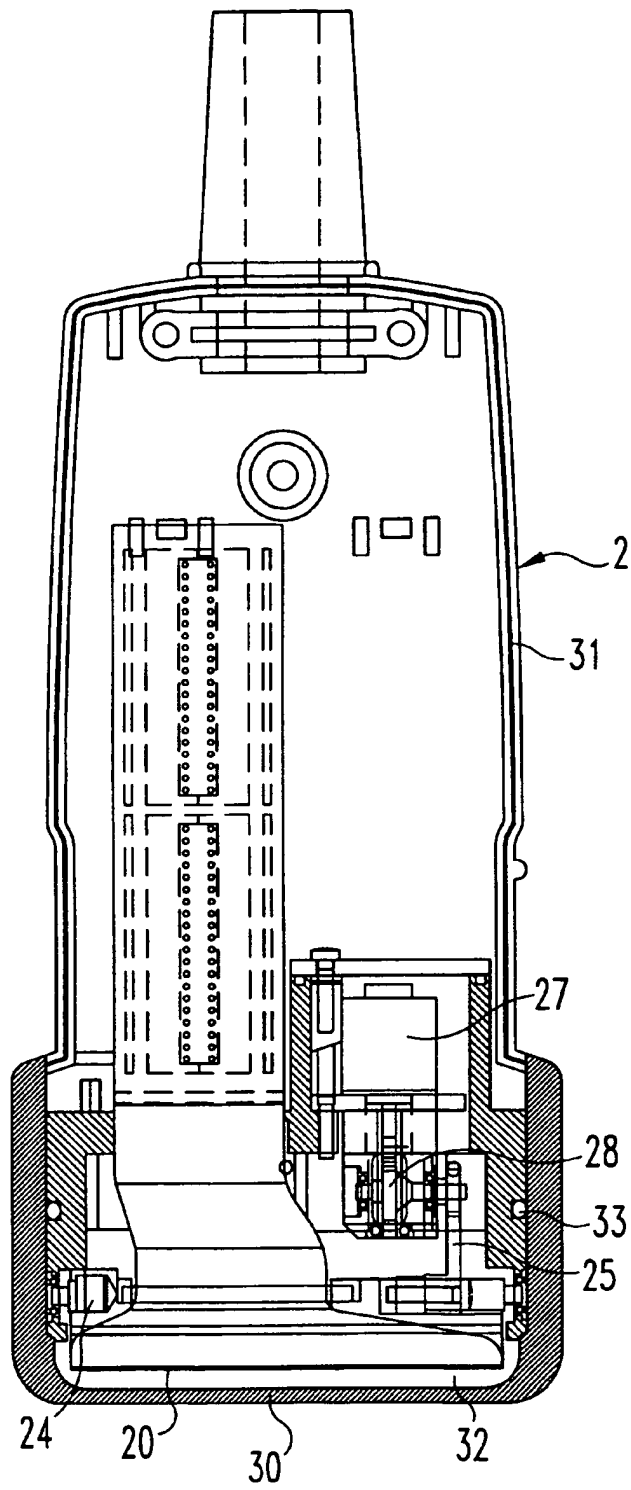

Fig. 4

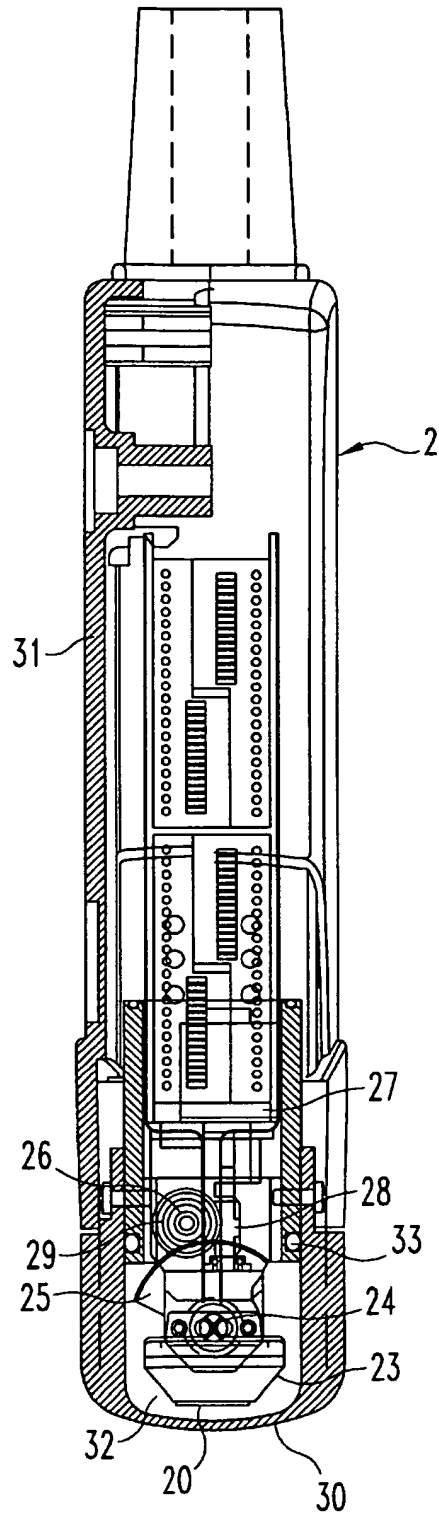

Fig. 5

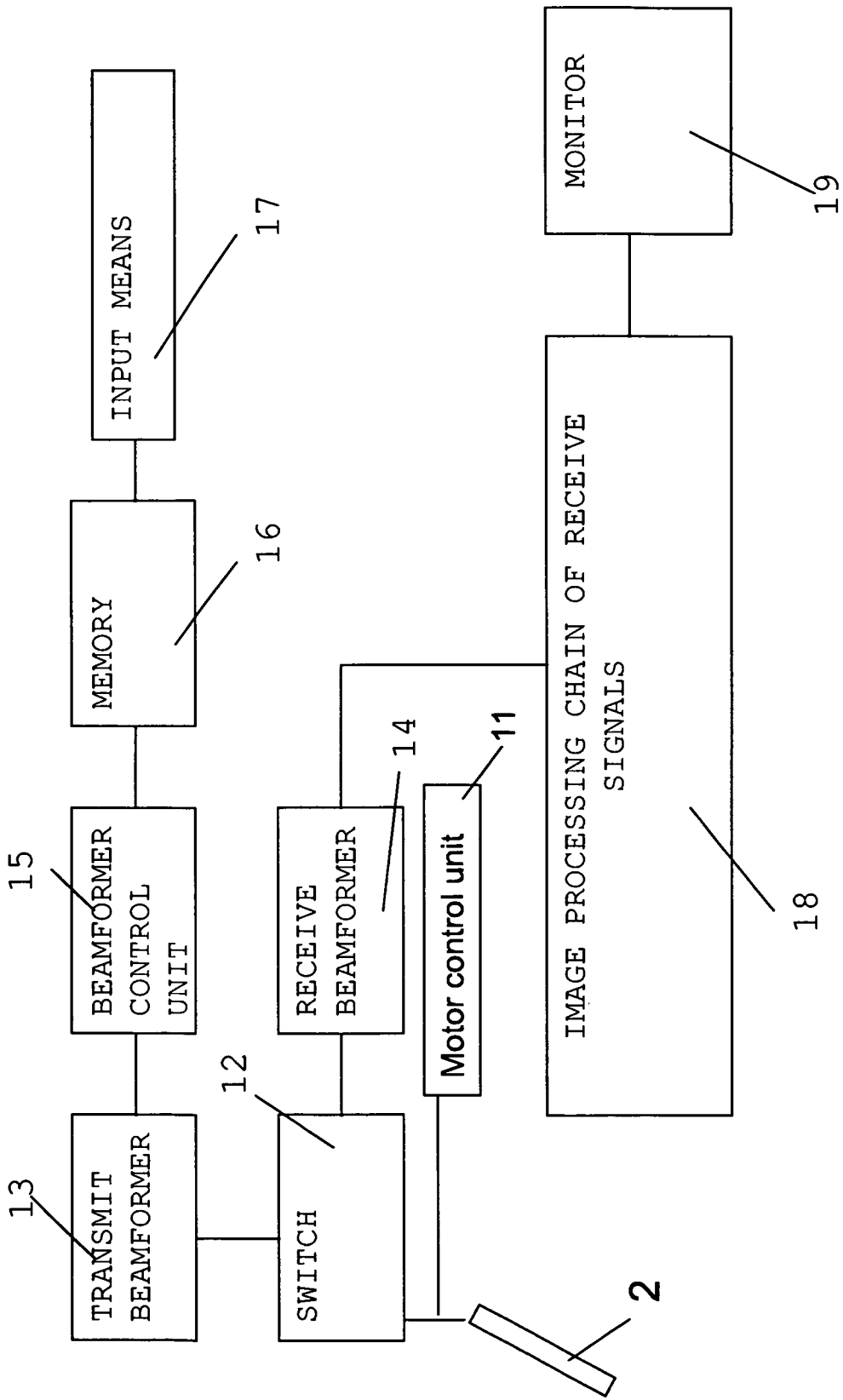

Fig. 6

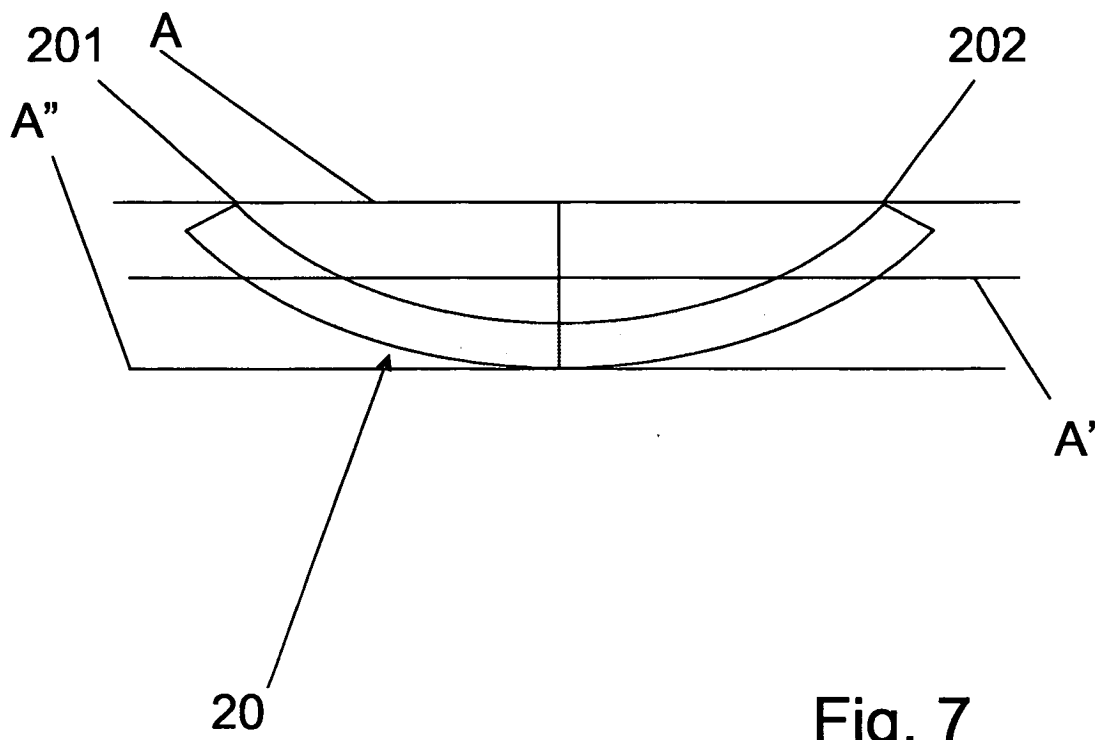
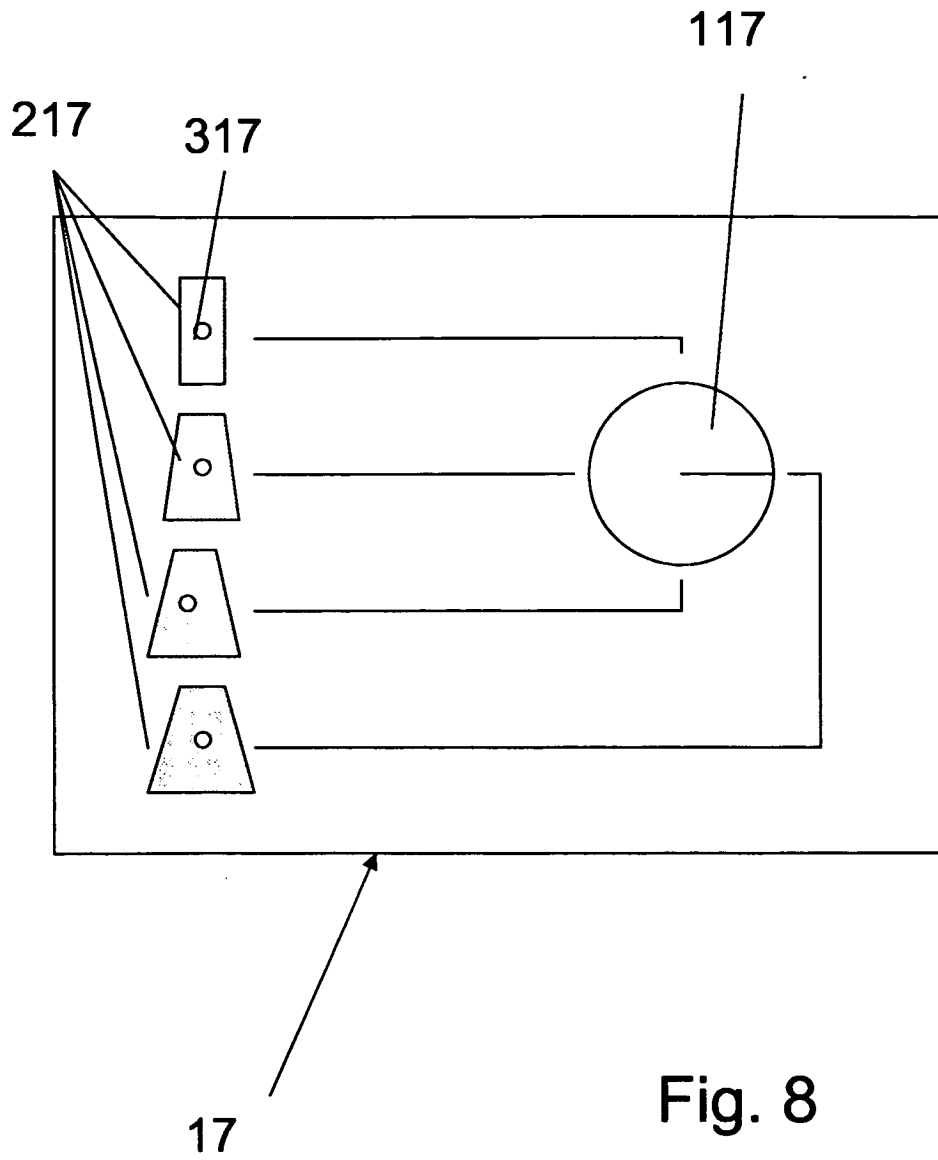

Fig. 7



REFERENCES CITED IN THE DESCRIPTION

This list of references cited by the applicant is for the reader's convenience only. It does not form part of the European patent document. Even though great care has been taken in compiling the references, errors or omissions cannot be excluded and the EPO disclaims all liability in this regard.

Patent documents cited in the description

- US 6572548 B [0002] [0036] [0061]
- US 5460179 A [0002]
- US 5447158 A [0023]
- US 6582372 B [0037] [0037]

专利名称(译)	三维妇科检查的超声成像方法和探头		
公开(公告)号	EP1681020B1	公开(公告)日	2008-06-04
申请号	EP2005100286	申请日	2005-01-18
[标]申请(专利权)人(译)	百胜集团		
申请(专利权)人(译)	ESAOTE S.P.A.		
当前申请(专利权)人(译)	ESAOTE S.P.A.		
[标]发明人	CEROFOLINI MARINO		
发明人	CEROFOLINI, MARINO		
IPC分类号	A61B8/14 A61B8/00 A61B8/12		
CPC分类号	A61B8/14 A61B8/4461 A61B8/483 G01S15/8918 G01S15/892 G01S15/894 G01S15/8993		
其他公开文献	EP1681020A1		
外部链接	Espacenet		

摘要(译)

特别是用于3D妇科检查的超声成像方法，该方法包括以下步骤：提供包括一定数量的换能器（120）的线性超声探头（2），所述换能器沿着一条线并排放置，形成所谓的线性阵列（20）；提供连接换能器的B模式成像扫描单元以及哪个扫描单元交替地为探头的每个换能器产生电驱动信号，用于激励换能器发射超声传输信号并接收由每个换能器产生的电信号。通过超声信号激励换能器反射形成目标体，超声传输信号已经发射到目标体上；定义超声波发射信号和超声波反射信号的传播方向的起始方向，沿着该超声波反射信号执行第一扫描步骤；执行第一个扫描步骤发射超声波发射信号并沿所述起始传播方向接收超声波反射信号；在横向于线性换能器阵列的纵向延伸的方向上并围绕与所述纵向延伸部重合或平行的轴或者与线性换能器阵列的中心纵向轴重合或平行的方向振荡探针，用于改变探针的取向。所述超声传输信号和超声反射信号的传播方向；沿着每个新的定向传播方向执行扫描步骤，该扫描步骤对应于探针的不同振荡角度；提供3D扫描转换器，其中存储与超声反射信号有关的接收信号；提供B模式图像产生装置，用于根据与超声反射信号有关的所述接收信号产生图像。根据本发明提供了以下进一步的步骤：操纵超声发射光束，使得线性阵列的换能器产生梯形扫描切片或平面在光束传播方向上发散，并提供反射光束信号聚焦规则，产生梯形图像对应于转向超声波束。

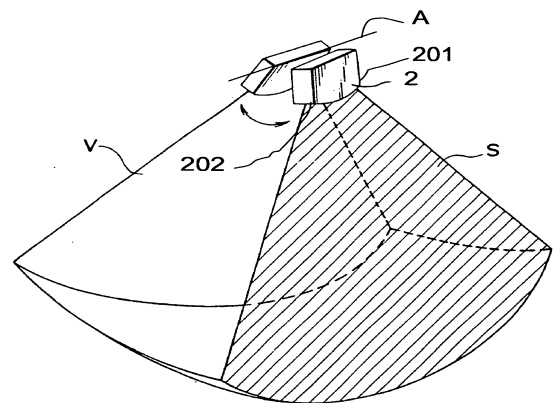

Fig. 1