



(12) **EUROPEAN PATENT APPLICATION**
 published in accordance with Art. 153(4) EPC

(43) Date of publication:
11.12.2019 Bulletin 2019/50

(51) Int Cl.:
A61B 8/14 (2006.01)

(21) Application number: **18748229.4**

(86) International application number:
PCT/JP2018/001326

(22) Date of filing: **18.01.2018**

(87) International publication number:
WO 2018/142950 (09.08.2018 Gazette 2018/32)

(84) Designated Contracting States:
AL AT BE BG CH CY CZ DE DK EE ES FI FR GB GR HR HU IE IS IT LI LT LU LV MC MK MT NL NO PL PT RO RS SE SI SK SM TR
 Designated Extension States:
BA ME
 Designated Validation States:
MA MD TN

(71) Applicant: **Fujifilm Corporation**
Minato-ku
Tokyo 106-8620 (JP)

(72) Inventor: **EBATA Tetsurou**
Ashigara-kami-gun
Kanagawa 258-8538 (JP)

(30) Priority: **01.02.2017 JP 2017016590**

(74) Representative: **Klunker IP**
Patentanwälte PartG mbB
Destouchesstraße 68
80796 München (DE)

(54) **ULTRASOUND DIAGNOSTIC DEVICE, ULTRASOUND DIAGNOSTIC DEVICE CONTROL METHOD AND ULTRASOUND DIAGNOSTIC DEVICE CONTROL PROGRAM**

(57) An ultrasound diagnostic apparatus 1 includes an image acquisition unit 3 that generates an ultrasound image, an image recognition unit 9 that performs image recognition for the ultrasound image to calculate recognition scores, an index value calculation unit 10 that calculates index values of a plurality of parts on the basis of the recognition scores calculated for a predetermined

number of ultrasound images, an order decision unit 11 that decides a determination order in which part determination is performed for the plurality of parts on the basis of the index values, and a part determination unit 12 that determines an imaging part of a subject on the basis of the recognition scores calculated according to the determination order.

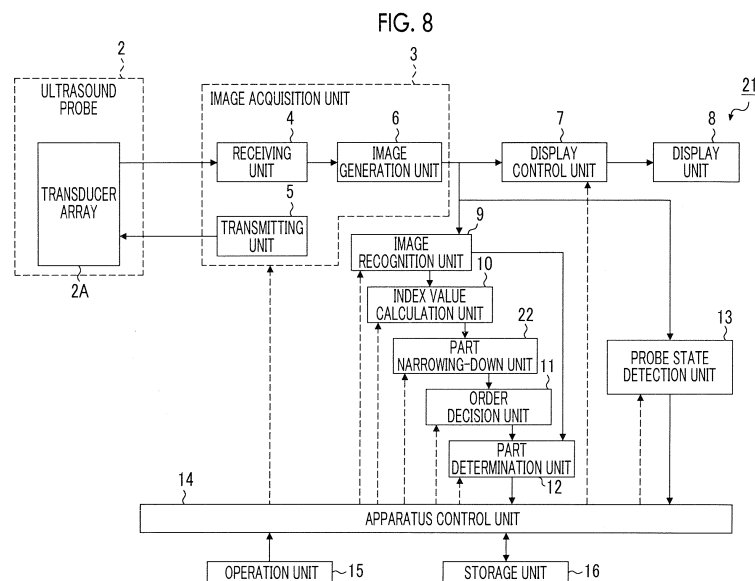

Description

BACKGROUND OF THE INVENTION

1. Field of the Invention

[0001] The present invention relates to an ultrasound diagnostic apparatus, a method for controlling an ultrasound diagnostic apparatus, and a program for controlling an ultrasound diagnostic apparatus, and more particularly, to an ultrasound diagnostic apparatus that determines an imaging part of a subject, a method for controlling the ultrasound diagnostic apparatus, and a program for controlling the ultrasound diagnostic apparatus.

2. Description of the Related Art

[0002] In recent years, an ultrasound diagnostic apparatus has been known as an apparatus for obtaining an image of the inside of a subject. In general, the ultrasound diagnostic apparatus comprises an ultrasound probe comprising a transducer array in which a plurality of elements are arranged. In a state in which the ultrasound probe is in contact with the body surface of the subject, ultrasound beams are transmitted from the transducer array to the subject and the transducer array receives ultrasound echoes from the subject. In this way, element data is acquired. In addition, the ultrasound diagnostic apparatus electrically processes the obtained element data to generate an ultrasound image of a corresponding part of the subject.

[0003] It has been known that, in a case in which the ultrasound image of a part of the subject is generated by the ultrasound diagnostic apparatus, there are imaging conditions suitable for each part. It is preferable that the imaging conditions are automatically set in a case in which the ultrasound image of each part is generated. However, it is necessary to automatically determine an imaging part of the subject which is currently being examined in order to automatically set the imaging conditions.

[0004] Therefore, various proposals have been made as the ultrasound diagnostic apparatus that can automatically determine an imaging part of a subject. For example, an ultrasound diagnostic apparatus disclosed in JP1992-224738A (JP-H04-224738A) includes a pattern memory that stores characteristic patterns of each part of a subject, collates an image pattern extracted from a generated ultrasound image with a plurality of pattern data items stored in the pattern memory, detects pattern data similar to the image pattern included in the generated ultrasound image, and determines an imaging part.

SUMMARY OF THE INVENTION

[0005] However, in general, the amount of calculation load required for image recognition that extracts an image pattern from a generated ultrasound image and col-

lates the extracted image pattern with pattern data stored in advance is large. In particular, in a case in which the image recognition is performed by an apparatus with a low processing performance, it takes a lot of time until the image recognition is completed. In addition, in the ultrasound diagnostic apparatus disclosed in JP1992-224738A (JP-H04-224738A), in a case in which the image recognition is performed for a plurality of parts of the subject, it is necessary to collate the image pattern extracted from the generated ultrasound image with many pattern data items corresponding to the plurality of parts. As a result, the time required to determine the imaging part further increases. In addition, in the ultrasound diagnostic apparatus disclosed in JP1992-224738A (JP-H04-224738A), this process needs to be performed for each of the plurality of parts of the subject.

[0006] The invention has been made in order to solve the problems of the related art and an object of the invention is to provide an ultrasound diagnostic apparatus that can reduce the time required to determine an imaging part, a method for controlling the ultrasound diagnostic apparatus, and a program for controlling the ultrasound diagnostic apparatus.

[0007] In order to achieve the object, an ultrasound diagnostic apparatus according to the invention comprises: an image acquisition unit that transmits an ultrasound beam from an ultrasound probe to a subject to generate an ultrasound image; an image recognition unit that performs image recognition for the ultrasound image generated by the image acquisition unit to calculate recognition scores of a plurality of parts of the subject; an index value calculation unit that calculates index values of the plurality of parts on the basis of the recognition scores of the plurality of parts calculated for a predetermined number of ultrasound images; an order decision unit that decides a determination order in which part determination is performed for the plurality of parts on the basis of the index values; and a part determination unit that determines an imaging part of the subject on the basis of the recognition scores calculated by the image recognition unit according to the determination order.

[0008] Preferably, the index value calculation unit uses, as the index values of the plurality of parts, recognition scores of the plurality of parts calculated by the image recognition unit for a latest ultrasound image acquired by the image acquisition unit.

[0009] The index value calculation unit may calculate the index values of the plurality of parts of the subject on the basis of recognition scores of the plurality of parts calculated by the image recognition unit for each of a plurality of ultrasound images which are continuously acquired in time series and include a latest ultrasound image acquired by the image acquisition unit.

[0010] Preferably, the index value calculation unit uses mean values or medians of the recognition scores of the plurality of parts calculated for the plurality of ultrasound images as the index values of the plurality of parts.

[0011] The index value calculation unit may use max-

imum values or minimum values of the recognition scores of the plurality of parts calculated for the plurality of ultrasound images as the index values of the plurality of parts.

[0012] The index value calculation unit may calculate weighted mean values of the recognition scores of the plurality of parts by giving a larger weight to an ultrasound image more recently acquired by the image acquisition unit among the plurality of ultrasound images and may use the weighted mean values as the index values of the plurality of parts.

[0013] The index value calculation unit may give ranking scores to the plurality of parts for each of the plurality of ultrasound images such that the part with a higher recognition score has a higher ranking score and may use sums of the ranking scores of the plurality of parts for the plurality of ultrasound images as the index values of the plurality of parts.

[0014] The index value calculation unit may have a threshold value of the recognition score and may use the number of recognition scores greater than the threshold value among the recognition scores of the plurality of parts calculated for the plurality of ultrasound images as the index value of each of the plurality of parts.

[0015] Preferably, in a case in which there are the same index values among the calculated index values of the plurality of parts, the index value calculation unit calculates the index values again, using an ultrasound image group which includes the latest ultrasound image and consists of ultrasound images which are continuous in time series and whose number is less than the number of the ultrasound images used to calculate the index values.

[0016] In a case in which there are the same index values among the calculated index values of the plurality of parts, the index value calculation unit may calculate the index values again, using an ultrasound image group consisting of a plurality of ultrasound images which are continuous in time series and are acquired by the image acquisition unit before the latest ultrasound image in time series.

[0017] Preferably, the ultrasound diagnostic apparatus further comprises a probe state detection unit that detects a change in the imaging part caused by movement of the ultrasound probe. Preferably, after the probe state detection unit detects the change in the imaging part, the index value calculation unit starts to calculate the index value.

[0018] Preferably, the order decision unit decides the determination order such that the part with a larger index value ranks higher.

[0019] According to the invention, there is provided a method for controlling an ultrasound diagnostic apparatus. The method comprises: transmitting an ultrasound beam from an ultrasound probe to a subject to generate an ultrasound image; performing image recognition for the ultrasound image to calculate recognition scores of a plurality of parts of the subject; calculating index values

of the plurality of parts on the basis of the recognition scores of the plurality of parts calculated for a predetermined number of ultrasound images; deciding a determination order in which part determination is performed for the plurality of parts on the basis of the index values; and determining an imaging part of the subject on the basis of the recognition scores calculated according to the determination order.

[0020] According to the invention, there is provided a program that controls an ultrasound diagnostic apparatus and causes a computer to perform: a step of transmitting an ultrasound beam from an ultrasound probe to a subject to generate an ultrasound image; a step of performing image recognition for the ultrasound image to calculate recognition scores of a plurality of parts of the subject; a step of calculating index values of the plurality of parts on the basis of the recognition scores of the plurality of parts calculated for a predetermined number of ultrasound images; a step of deciding a determination order in which part determination is performed for the plurality of parts on the basis of the index values; and a step of determining an imaging part of the subject on the basis of the recognition scores calculated according to the determination order.

[0021] According to the invention, the ultrasound diagnostic apparatus includes the order decision unit that decides the determination order in which part determination is performed and determines an imaging part on the basis of the determination order. Therefore, it is possible to reduce the time required to determine the imaging part.

BRIEF DESCRIPTION OF THE DRAWINGS

[0022]

Fig. 1 is a block diagram illustrating the configuration of an ultrasound diagnostic apparatus according to Embodiment 1 of the invention.

Fig. 2 is a block diagram illustrating the internal configuration of a receiving unit illustrated in Fig. 1.

Fig. 3 is a block diagram illustrating the internal configuration of an image generation unit illustrated in Fig. 1.

Fig. 4 is a flowchart illustrating an operation of the ultrasound diagnostic apparatus according to Embodiment 1 of the invention.

Fig. 5 is a flowchart illustrating a part determination operation of the ultrasound diagnostic apparatus according to Embodiment 1 of the invention.

Fig. 6 is a flowchart illustrating an operation of an ultrasound diagnostic apparatus according to Embodiment 2 of the invention.

Fig. 7 is a flowchart illustrating a part determination operation of an ultrasound diagnostic apparatus according to Embodiment 3 of the invention.

Fig. 8 is a block diagram illustrating the configuration of an ultrasound diagnostic apparatus according to Embodiment 4 of the invention.

Fig. 9 is a flowchart illustrating a part determination operation of the ultrasound diagnostic apparatus according to Embodiment 4 of the invention.

DESCRIPTION OF THE PREFERRED EMBODIMENTS

[0023] Hereinafter, embodiments of the invention will be described with reference to the accompanying drawings.

Embodiment 1

[0024] Fig. 1 illustrates the configuration of an ultrasound diagnostic apparatus according to Embodiment 1 of the invention. An ultrasound diagnostic apparatus 1 comprises an ultrasound probe 2 provided with a transducer array 2A. A display control unit 7 and a display unit 8 are sequentially connected to the ultrasound probe 2 through an image acquisition unit 3.

[0025] The image acquisition unit 3 includes a receiving unit 4 and a transmitting unit 5 that are connected to the transducer array 2A of the ultrasound probe 2, and an image generation unit 6 that is connected to the receiving unit 4. The display control unit 7 is connected to the image generation unit 6. In addition, an image recognition unit 9 is connected to the image generation unit 6. An index value calculation unit 10 is connected to the image recognition unit 9. An order decision unit 11 is connected to the index value calculation unit 10. A part determination unit 12 is connected to the order decision unit 11. Further, the image recognition unit 9 is connected to the part determination unit 12. Furthermore, a probe state detection unit 13 is connected to the image generation unit 6.

[0026] In addition, an apparatus control unit 14 is connected to the image acquisition unit 3, the display control unit 7, the image recognition unit 9, the index value calculation unit 10, the order decision unit 11, the part determination unit 12, and the probe state detection unit 13. An operation unit 15 and a storage unit 16 are connected to the apparatus control unit 14. The apparatus control unit 14 and the storage unit 16 are connected such that information can be bi-directionally transmitted and received therebetween.

[0027] The transducer array 2A of the ultrasound probe 2 illustrated in Fig. 1 includes a plurality of elements (ultrasound transducers) which are one-dimensionally or two-dimensionally arranged. Each of the elements transmits ultrasonic waves in response to a driving signal supplied from the transmitting unit 5. In addition, each of the elements receives ultrasound echoes from a subject and outputs a received signal. Each of the elements is, for example, a transducer in which electrodes are formed at both ends of a piezoelectric body made of piezoelectric ceramic typified by lead zirconate titanate (PZT), a polymer piezoelectric element typified by polyvinylidene difluoride (PVDF), or a piezoelectric single crystal typified

by lead magnesium niobate-lead titanate (PMN-PT).

[0028] In a case in which a pulsed voltage or a continuous-wave voltage is applied to the electrodes of the transducer, the piezoelectric body is expanded and contracted and pulsed or continuous ultrasonic waves are generated from each transducer. The ultrasonic waves are combined to form an ultrasound beam. In addition, each transducer receives propagated ultrasonic waves, is expanded and contracted, and generates an electric signal. The electric signal is output as a received ultrasound signal from each transducer to the receiving unit 4.

[0029] As illustrated in Fig. 2, the receiving unit 4 of the image acquisition unit 3 has a configuration in which an amplification unit 17 and an analog/digital (A/D) conversion unit 18 are connected in series to each other. The receiving unit 4 outputs, to the image generation unit 6, element data obtained by amplifying the received signal output from each element of the transducer array 2A with the amplification unit 17 and converting the amplified signal into a digital signal with the A/D conversion unit 18.

[0030] The transmitting unit 5 of the image acquisition unit 3 includes, for example, a plurality of pulse generators, adjusts the amount of delay of each driving signal such that the ultrasonic waves transmitted from the plurality of elements of the transducer array 2A form an ultrasound beam, on the basis of a transmission delay pattern selected according to a control signal from the apparatus control unit 14, and supplies the driving signals to the plurality of elements.

[0031] As illustrated in Fig. 3, the image generation unit 6 of the image acquisition unit 3 has a configuration in which a brightness-mode (B-mode) processing unit 19 and an image processing unit 20 are sequentially connected in series to each other.

[0032] The B-mode processing unit 19 performs a reception focusing process which applies a delay to each element data item following a set sound speed on the basis of a reception delay pattern selected according to a control signal from the apparatus control unit 14 and adds the received data (phasing addition). A sound ray signal in which the focus of the ultrasound echo is narrowed is generated by the reception focusing process. In addition, the B-mode processing unit 19 corrects the attenuation of the sound ray signal caused by a propagation distance according to the depth of the reflection position of ultrasonic waves and then performs an envelope detection process to generate a B-mode image signal which is tomographic image information related to the tissues in the subject. The B-mode image signal generated by the B-mode processing unit 19 is output to the image processing unit 20.

[0033] The image processing unit 20 converts the B-mode image signal generated by the B-mode processing unit 19 into an image signal based on a general television signal scanning system (raster conversion), performs various types of necessary image processing, such as a gradation process, for the B-mode image signal, and outputs a B-mode image signal, that is, an ultrasound image

to the display control unit 7 and the image recognition unit 9.

[0034] As illustrated in Fig. 1, the display control unit 7 of the ultrasound diagnostic apparatus 1 directs the display unit 8 to display the ultrasound image on the basis of the B-mode image signal acquired by the image acquisition unit 3.

[0035] The display unit 8 includes a display device, such as a liquid crystal display (LCD), and displays the ultrasound image under the control of the apparatus control unit 14.

[0036] The image recognition unit 9 receives the ultrasound image subjected to various types of image processing from the image processing unit 20 of the image generation unit 6 and performs image recognition, such as pattern recognition, for the ultrasound image to calculate recognition scores of a plurality of parts of the subject. Here, the recognition scores of the plurality of parts of the subject are the similarities of imaging parts in the ultrasound image to the plurality of parts of the subject. As the value of the similarity becomes larger, the probability of the imaging part in the ultrasound image being the corresponding part becomes higher.

[0037] The index value calculation unit 10 calculates the index values of the plurality of parts of the subject on the basis of the recognition scores of the plurality of parts of the subject calculated by the image recognition unit 9. There are various methods for calculating the index values. Hereinafter, for the purpose of description, it is assumed that the index values of the plurality of parts of the subject are the mean values of the recognition scores of the plurality of parts of the subject calculated for a plurality of ultrasound images. As such, in a case in which the index values are calculated on the basis of the recognition scores for a plurality of ultrasound images, the index value calculation unit 10 calculates the index values on the basis of the recognition scores for a plurality of ultrasound images which are continuously acquired in time series and include the latest ultrasound image acquired by the image acquisition unit 3.

[0038] The order decision unit 11 decides a determination order in which imaging part determination is performed for the plurality of parts of the subject on the basis of the index values of the plurality of parts of the subject calculated by the index value calculation unit 10. At that time, the order decision unit 11 decides the determination order such that a part with a high probability of being the imaging part whose image is currently captured ranks higher.

[0039] The part determination unit 12 determines the imaging part of the subject for the ultrasound image acquired by the image acquisition unit 3 on the basis of the recognition scores calculated by the image recognition unit 9 according to the determination order. That is, the part determination unit 12 sequentially determines the imaging part from the part that ranks first among the plurality of parts of the subject according to the determination order decided by the order decision unit 11.

[0040] The probe state detection unit 13 determines whether the ultrasound probe 2 is in an aerial emission state. Here, the aerial emission state of the ultrasound probe 2 means a state in which the ultrasound probe 2 is separated from the body surface of the subject and the ultrasound beam transmitted from the transducer array 2A to the subject is emitted to the air. In a case in which the ultrasound probe 2 is in the aerial emission state, the ultrasound beam emitted from the transducer array 2A is not reflected from a part of the subject and the received signal generated in the transducer array 2A does not have sufficient intensity. As a result, the image of the part is not included in the ultrasound image generated by the image generation unit 6. Therefore, the probe state detection unit 13 determines that the ultrasound probe 2 is in the aerial emission state in a case in which no image is included in the ultrasound image and determines that the ultrasound probe 2 is in contact with the subject in a case in which an image is included in the ultrasound image.

[0041] The apparatus control unit 14 controls each unit of the ultrasound diagnostic apparatus 1 on the basis of commands input by an operator through the operation unit 15.

[0042] The operation unit 15 is used by the operator to perform an input operation and may include, for example, a keyboard, a mouse, a trackball, and a touch panel.

[0043] The storage unit 16 stores, for example, an operation program of the ultrasound diagnostic apparatus 1 and may be a recording medium, such as a hard disc drive (HDD), a solid state drive (SSD), a flexible disc (FD), a magneto-optical (MO) disc, a magnetic tape (MT), a random access memory (RAM), a compact disc (CD), a digital versatile disc (DVD), a secure digital (SD) card, or a universal serial bus (USB) memory, or a server.

[0044] The image generation unit 6 of the image acquisition unit 3, the display control unit 7, the image recognition unit 9, the index value calculation unit 10, the order decision unit 11, the part determination unit 12, the probe state detection unit 13, and the apparatus control unit 14 are implemented by a central processing unit (CPU) and a control program that causes the CPU to perform various processes. However, these units may be implemented by a digital circuit and a computer. In addition, some or all of the image generation unit 6, the display control unit 7, the image recognition unit 9, the index value calculation unit 10, the order decision unit 11, the part determination unit 12, the probe state detection unit 13, and the apparatus control unit 14 may be integrated into one CPU.

[0045] Next, the operation of the ultrasound diagnostic apparatus 1 according to Embodiment 1 will be described with reference to a flowchart illustrated in Fig. 4.

[0046] First, in Step S1, the receiving unit 4 and the transmitting unit 5 of the image acquisition unit 3 perform the transmission and reception of ultrasound beams and scanning, that is, the capture of an ultrasound image,

using the plurality of ultrasound transducers of the transducer array 2A in the ultrasound probe 2. At that time, each ultrasound transducer which has received ultrasound echoes from the subject generates a received signal and the received signal is input to the receiving unit 4. The amplification unit 17 of the receiving unit 4 amplifies the received signal input to the receiving unit 4. In addition, the A/D conversion unit 18 performs A/D conversion for the received signal. Furthermore, the received signal is input to the image generation unit 6. The B-mode processing unit 19 of the image generation unit 6 generates a B-mode image, that is, an ultrasound image.

[0047] Then, in Step S2, the probe state detection unit 13 determines whether the ultrasound probe 2 is in the aerial emission state. In a case in which it is determined in Step S2 that the ultrasound probe 2 is in the aerial emission state, the process returns to Step S1. On the other hand, in a case in which it is determined in Step S2 that the ultrasound probe 2 is not in the aerial emission state and is in contact with the body surface of the subject, the process proceeds to Step S3.

[0048] In Step S3, the imaging part that is currently being examined is determined. The part determination in Step S3 will be described in detail below with reference to Fig. 5.

[0049] In a case in which the imaging part is determined in Step S3, the process proceeds to Step S4. In Step S4, the apparatus control unit 14 sets imaging conditions suitable for the part determined in Step S3. Here, the imaging conditions include, for example, a frame rate in ultrasound diagnosis, the resolution of an ultrasound image, the brightness of an ultrasound image, and a dynamic range in ultrasound diagnosis.

[0050] Then, in Step S5, the image acquisition unit 3 acquires an ultrasound image. At that time, since the imaging conditions set in Step S4 are used as the imaging conditions, the image acquisition unit 3 can acquire the ultrasound image in which the image of the imaging part is clear.

[0051] Then, in Step S6, it is determined again whether the ultrasound probe 2 is in the aerial emission state. Here, in a case in which the probe state detection unit 13 determines that the ultrasound probe 2 is not in the aerial emission state and is in contact with the body surface of the subject, it is determined that the imaging part has not been changed and the process returns to Step S5 to acquire an ultrasound image again. On the other hand, in a case in which the probe state detection unit 13 determines that the ultrasound probe 2 is in the aerial emission state, it is determined that a change in the imaging part has started and the process returns to Step S1.

[0052] Next, the part determination in Step S3 will be described with reference to Fig. 5. In a case in which the part determination in Step S3 starts, first, an ultrasound image is acquired in Step S7.

[0053] Then, in Step S8, the image recognition unit 9 calculates the recognition scores of a plurality of parts of the subject for the ultrasound image acquired in Step S7.

[0054] Then, in Step S9, the apparatus control unit 14 determines whether the recognition scores of a plurality of parts of the subject have been calculated for a predetermined number of frames of ultrasound images. Here, the part determination process in Step S3 has the determination step of Step S9 in order to obtain the number of recognition scores required for the index value calculation unit 10 to calculate the index values. Therefore, in a case in which it is determined in Step S9 that the recognition scores have not been calculated for a predetermined number of frames of ultrasound images, the process returns to Step S7 to acquire an ultrasound image. Then, in Step S8, a new recognition score is calculated. As such, in a case in which it is determined in Step S9 that the recognition scores of a plurality of parts of the subject have been calculated for a predetermined number of frames of ultrasound images after the repetition of Steps S7 and S8, the process proceeds to Step S10.

[0055] In Step S10, the index value calculation unit 10 averages a predetermined number of recognition scores calculated by the repetition of Steps S7 and S8 for each of a plurality of parts to calculate the index values of the plurality of parts of the subject.

[0056] Then, in Step S11, the order decision unit 11 decides the determination order of the plurality of parts of the subject such that, as the index values of the plurality of parts of the subject calculated in Step S10 become larger, the rankings become higher. For example, in a case in which the plurality of parts of the subject include the heart and the lung, the heart has the largest index value, and the lung has the second largest index value, the heart ranks first and the lung ranks second.

[0057] Then, in Step S12, in a case in which the image acquisition unit 3 acquires a new ultrasound image, the process proceeds to Step S13.

[0058] In Step S13, the image recognition unit 9 calculates the recognition score of the part that ranks first according to the determination order decided in Step S11 for the latest ultrasound image acquired in Step S12. For example, in a case in which the heart ranks first in the determination order, only the recognition score of the heart is calculated for the ultrasound image acquired in Step S12.

[0059] Then, in Step S14, the part determination unit 12 performs threshold value determination of whether the recognition score of one part calculated in Step S13 is greater than a determination threshold value. The determination threshold value is the threshold value of the recognition score in part determination and the same determination threshold value can be used for all of the parts. In a case in which it is determined in Step S14 that the recognition score of one part is equal to or less than the determination threshold value, it is determined that it is difficult to decide the imaging part as the part whose recognition score has been calculated in Step S13 and the process proceeds to Step S15.

[0060] In Step S15, the apparatus control unit 14 de-

termines whether the threshold value determination for the recognition scores of all of the plurality of parts of the subject has been completed in Step S14. In a case in which it is determined in Step S15 that the threshold value determination for the recognition scores of all of the plurality of parts of the subject has not been completed in Step S14, the process proceeds to Step S16.

[0061] In Step S16, the apparatus control unit 14 updates a determination part. That is, the apparatus control unit 14 changes the part whose recognition score is to be calculated in the next Step S13 from the part that ranks first to the part that ranks second in the determination order decided in Step S11. Hereinafter, for the purpose of description, among the parts of the subject which rank according to the determination order decided in Step S11, the part to be determined to be the imaging part, that is, the part to be determined in Step S14 is referred to as the determination part. In a case in which the determination part is updated, the process returns to Step S13 in order to determine the imaging part for the next part on the basis of the determination order.

[0062] In Step S13 performed for the second time, only the recognition score of the part that ranks second in the determination order decided in Step S11 is calculated for the ultrasound image acquired in Step S12. Then, in Step S14, the part determination unit 12 determines whether the recognition score of the part that ranks second in the determination order is greater than the determination threshold value. Here, in a case in which it is determined that the recognition score is equal to or less than the determination threshold value, the process proceeds to Step S15.

[0063] As such, as long as it is determined in Step S14 that the recognition score of the determination part is equal to or less than the determination threshold value, Steps S13 to S16 are repeated according to the determination order decided in Step S11. In a case in which it is determined in Step S15 that the threshold value determination for the recognition scores of all of the plurality of parts of the subject has been completed in Step S14 as a result of the repetition of Steps S13 to S16, it is determined that it is difficult to decide the part included in the ultrasound image acquired in Step S12 to be any of the plurality of parts of the subject and the process returns to Step S8. In the subsequent Steps S8 to S14, the index values of the plurality of parts of the subject are newly calculated on the basis of the newly calculated recognition scores of the plurality of parts of the subject and a new determination order is decided on the basis of the index values. In addition, the recognition scores are calculated for the ultrasound image newly acquired in Step S12 according to the newly decided determination order and part determination is performed for the imaging part on the basis of the recognition scores.

[0064] In a case in which it is determined in Step S14 that the recognition score of the determination part is greater than the determination threshold value, the process proceeds to Step S17.

[0065] In Step S17, the part determination unit 12 decides the imaging part whose image is currently captured to be the determination part having the recognition score determined to be greater than the determination threshold value in Step S14. Then, the part determination operation ends.

[0066] The ultrasound diagnostic apparatus 1 according to the above-described Embodiment 1 decides the determination order such that the part with a high probability of being the imaging part whose image is currently captured ranks higher and sequentially determines a plurality of parts of the subject according to the determination order in a case in which part determination is performed. Therefore, it is possible to reduce the calculation load of the ultrasound diagnostic apparatus 1 and to reduce the time required to determine the imaging part.

[0067] The index value calculation unit 10 averages the recognition scores of the plurality of parts of the subject calculated for a plurality of ultrasound images to calculate the index values of the plurality of parts of the subject. However, for example, the number of ultrasound images required for the index value calculation unit 10 to calculate the index value may be set by the operator through the operation unit 15 or the like, or may be stored in the index value calculation unit 10 and the storage unit 16 in advance.

[0068] In addition, the index value calculation unit 10 may calculate the index value using various methods other than the method of averaging the recognition scores of each of the plurality of parts of the subject. For example, the index value calculation unit 10 may use the medians of the recognition scores of the plurality of parts of the subject calculated for a plurality of ultrasound images as the index values of the plurality of parts of the subject.

[0069] In addition, for example, the index value calculation unit 10 may use the maximum values of the recognition scores of the plurality of parts of the subject calculated for a plurality of ultrasound images as the index values of the plurality of parts of the subject. Further, the index value calculation unit 10 may use the minimum values of the recognition scores of the plurality of parts of the subject calculated for a plurality of ultrasound images as the index values of the plurality of parts of the subject.

[0070] Furthermore, for example, the index value calculation unit 10 may use weighted mean values obtained by weighting and averaging the recognition scores of the plurality of parts of the subject calculated for a plurality of ultrasound images as the index values of the plurality of parts of the subject. In this case, the index value calculation unit 10 may calculate the weighted mean value by giving a larger weight to the recognition score calculated for an ultrasound image more recently acquired by the image acquisition unit 3 among the plurality of ultrasound images.

[0071] For example, the index value calculation unit 10 may give ranking scores to a plurality of parts of the subject for each of a plurality of ultrasound images such that

the ranking score becomes higher as the recognition score becomes higher. In this case, the index value calculation unit 10 can use the sums of the ranking scores of the plurality of parts of the subject for the plurality of ultrasound images as the index values of the plurality of parts of the subject. That is, for example, for each ultrasound image, the ranking scores are given to the plurality of parts of the subject such that a higher score is given to the part with a higher recognition score in the order of five points, four points, three points, two points, and one point and the ranking scores of each part for the plurality of ultrasound images are added up to calculate the index values of the plurality of parts of the subject.

[0072] In addition, for example, the index value calculation unit 10 may have a threshold value of the recognition score and calculate the index value from the result of threshold value determination for the recognition score. In this case, the index value calculation unit 10 can use the number of recognition scores that are greater than the threshold value among the recognition scores of the plurality of parts of the subject calculated for the plurality of ultrasound images as the index values of the plurality of parts of the subject. That is, for example, in a case in which the number of recognition scores that are greater than the threshold value among the recognition scores of the heart calculated for a plurality of ultrasound images is 3, the index value calculation unit 10 can set the index value of the heart to 3.

[0073] As described above, the index value calculation unit 10 can calculate the index values on the basis of the recognition scores calculated for a plurality of frames of ultrasound images. However, the index value calculation unit 10 may use the recognition scores calculated for one frame of ultrasound image as the index values. For example, the index value calculation unit 10 can use the recognition scores of a plurality of parts of the subject calculated only for the latest ultrasound image acquired by the image acquisition unit 3 as the index values of the plurality of parts of the subject.

[0074] In addition, in a case in which there are the same index values among the calculated index values of the plurality of parts of the subject, the index value calculation unit 10 may calculate the index values again. In this case, the index value calculation unit 10 can calculate the index values again, using the recognition scores calculated for an ultrasound image group that includes the latest ultrasound image acquired by the image acquisition unit 3 and consists of ultrasound images whose number is less than the number of ultrasound images used in a case in which the same index values have been calculated. It is preferable that the ultrasound image group used here is continuously acquired in time series by the image acquisition unit 3.

[0075] In addition, in a case in which the index values are calculated again, the index value calculation unit 10 may calculate the index values, using the recognition scores calculated for an ultrasound image group consisting of a plurality of ultrasound images that are acquired

by the image acquisition unit 3 before the latest ultrasound image in time series and are continuous in time series.

[0076] In the above-described embodiment, in a case in which no image is included in the acquired ultrasound image, the probe state detection unit 13 determines that the ultrasound probe 2 is in the aerial emission state. However, the probe state detection unit 13 may compare a plurality of ultrasound images acquired in time series to determine whether the ultrasound probe 2 is in the aerial emission state. That is, the probe state detection unit 13 may compare a plurality of ultrasound images acquired in time series and may determine that the ultrasound probe 2 is not in contact with the body surface and is in the aerial emission state in a case in which there is no change in the images included in the plurality of ultrasound images between the plurality of ultrasound images. In addition, in a case in which there is a change in the images included in the plurality of ultrasound images acquired in time series between the plurality of ultrasound images, the probe state detection unit 13 may determine that a part of the subject is included in the plurality of ultrasound images and the ultrasound probe 2 is in contact with the body surface of the subject.

[0077] With this configuration, even in the case in which ultrasonography gel is attached to the ultrasound probe 2, the probe state detection unit 13 can compare a plurality of ultrasound images acquired in time series to determine whether the ultrasound probe 2 is in the aerial emission state.

[0078] In the flowchart illustrated in Fig. 4, in a case in which the probe state detection unit 13 detects a change in the imaging part, the part determination in Step S3 starts. This means that, in a case in which the probe state detection unit 13 detects a change in the imaging part, the index value calculation unit 10 starts to calculate the index value on the basis of the recognition score calculated for a newly acquired ultrasound image. As such, it is possible to reduce the calculation load of the ultrasound diagnostic apparatus 1 by calculating the index value for the ultrasound image only while the ultrasound probe 2 is in contact with the body surface of the subject. In addition, in a case in which the index value calculation unit 10 calculates the index values, it is possible to prevent the index value calculation unit 10 from using the recognition scores before the imaging part is changed.

[0079] In addition, the index value calculation unit 10 may start the calculation of the index values for a plurality of parts of the subject after a predetermined period of time has elapsed since the probe state detection unit 13 has detected a change in the imaging part. For example, the time until the index value calculation unit 10 calculates the index values of the plurality of parts of the subject after the probe state detection unit 13 detects a change in the imaging part may be input by the operator through the operation unit 15 or the like, or may be stored in advance in the storage unit 16.

[0080] The time until the ultrasound probe 2 is brought

into contact with the body surface of the subject to obtain the ultrasound image of a target imaging part varies depending on, for example, the skill of the operator. In some cases, immediately after the imaging part is changed, an ultrasound image that is sufficiently clear to calculate the recognition score is not obtained. For this reason, in a case in which the calculation of the index values of a plurality of parts of the subject starts after a predetermined period of time has elapsed since the probe state detection unit 13 has detected a change in the imaging part, it is possible to calculate the index values on the basis of a plurality of recognition scores calculated for the ultrasound image that is sufficiently clear to calculate the recognition scores. Therefore, it is possible to improve the accuracy of calculating the index value.

[0081] In addition, in the flowchart illustrated in Fig. 5, Steps S12 and S13 may be omitted. In this case, if the determination order in which the imaging part is determined is decided in Step S11, the process proceeds to Step S14. In Step S14, the part determination unit 12 compares the recognition score of the part that ranks first in the determination order among the recognition scores of the plurality of parts of the subject calculated in Step S8 for the latest ultrasound image acquired in Step S7 with the determination threshold value. At that time, in a case in which the recognition score is equal to or less than the determination threshold value, the process proceeds to Step S15. Further, in a case in which it is determined in Step S15 that the threshold value determination for the recognition scores of all of the plurality of parts of the subject has not been performed in Step S14, the process proceeds to Step S16. In a case in which the determination part is updated in Step S16, it is determined in Step S14 whether the recognition score of the part that ranks second in the determination order is greater than the determination threshold value.

[0082] In the above-described embodiment, the same determination threshold value is used for all of the parts by the part determination unit 12 in Step S14. However, the determination threshold value may be set for each of the plurality of parts of the subject.

[0083] The above-mentioned ultrasound diagnostic apparatus 1 may be a portable ultrasound diagnostic apparatus that is small and can be easily carried and used or a stationary ultrasound diagnostic apparatus that is installed and used in, for example, a medical examination room.

[0084] In addition, the ultrasound probe 2 is not particularly limited as long as it can transmit and receive ultrasound beams to and from the subject and may be a sector type, a convex type, a linear type, or a radial type.

Embodiment 2

[0085] In the operation of the ultrasound diagnostic apparatus 1 illustrated in the flowchart of Fig. 4, in a case in which the ultrasound probe 2 is in the aerial emission state in Step S6, the process returns to Step S1. Then,

in Step S3, the part determination is performed for all of the plurality of parts of the subject. However, the part of the subject which has been decided in Step S3 may be excluded. In this case, it is possible to further reduce the calculation load of the ultrasound diagnostic apparatus 1 in the part determination.

[0086] Fig. 6 illustrates the operation of an ultrasound diagnostic apparatus according to Embodiment 2. Since Steps S1 to S6 in a flowchart illustrated in Fig. 6 are the same as Steps S1 to S6 in the flowchart illustrated in Fig. 4, the detailed description thereof will not be repeated.

[0087] In a case in which the probe state detection unit 13 determines that the ultrasound probe 2 is in the aerial emission state in Step S6, the process proceeds to Step S18. In Step S18, the apparatus control unit 14 determines whether all of a plurality of parts of the subject have been decided. In a case in which it is determined in Step S18 that all of the plurality of parts of the subject have not been decided, the process proceeds to Step S19.

[0088] In Step S19, the apparatus control unit 14 excludes the part that has been decided in the part determination of Step S3, that is, the decided part from the determination target in the next Step S3. In a case in which the process in Step S19 is completed, the process returns to Step S1. Then, in a case in which it is determined in Step S2 that the ultrasound probe 2 is not in the aerial emission state, the part determination is performed in Step S3. At that time, since the parts other than the part which has been excluded in Step S19 among the plurality of parts of the subject are the determination targets, the number of part candidates to be determined for the imaging part can be less than that in the part determination of Step S3 performed for the first time.

[0089] Steps S1 to S19 are repeated in this way to reduce the number of determination targets. As a result, in a case in which it is determined in Step S18 that all of the plurality of parts of the subject have been decided, the operation of the ultrasound diagnostic apparatus ends.

[0090] As such, Steps S1 to S19 are repeated to reduce the number of determination targets. Therefore, it is possible to reduce the calculation load of the ultrasound diagnostic apparatus in the part determination of Step S3 whenever Step S19 is performed and to reduce the time required to determine the imaging part.

Embodiment 3

[0091] In the part determination operation according to Embodiment 1 illustrated in Fig. 5, in the threshold value determination of Step S14, the recognition score of one part of the subject which has been calculated for the ultrasound image newly acquired in Step S12 by the image recognition unit 9 is used. However, recognition scores for part determination which have been calculated on the basis of the recognition scores calculated for a plurality of ultrasound images may be used for the thresh-

old value determination.

[0092] Fig. 7 is a flowchart illustrating a part determination operation of an ultrasound diagnostic apparatus according to Embodiment 3. The flowchart illustrated in Fig. 7 is the same as the flowchart illustrated in Fig. 5 except for Steps S20 to S22.

[0093] In the flowchart illustrated in Fig. 7, in a case in which the part determination operation starts, first, Steps S7 to S9 are repeated until the recognition scores of a plurality of parts of the subject are calculated for a predetermined number of frames of ultrasound images. Here, the predetermined number of frames is referred to as a first predetermined number of frames for the purpose of description. In a case in which it is determined in Step S9 that the recognition scores of the plurality of parts of the subject are calculated for the first predetermined number of frames of ultrasound images, the process proceeds to Step S10. In a case in which the index values of the plurality of parts of the subject are calculated from the recognition scores of the plurality of parts of the subject calculated for the first predetermined number of frames of ultrasound images in Step S10, a determination order is decided in Step S11.

[0094] Then, an ultrasound image is newly acquired in Step S12 and the process proceeds to Step S20. Step S20 is the same as Step S8 in the flowchart illustrated in Fig. 5. In a case in which the recognition scores of the plurality of parts of the subject are calculated for the latest ultrasound image in Step S20, the process proceeds to Step S21.

[0095] In Step S21, the apparatus control unit 14 determines whether recognition scores have been calculated for a second predetermined number of frames of ultrasound images acquired in Step S12. This is to obtain the number of recognition scores necessary to calculate the recognition scores for part determination. Therefore, in a case in which it is determined in Step S21 that the recognition scores have not been calculated for the second predetermined number of frames of ultrasound images, the process returns to Step S12 and an ultrasound image is newly acquired. Then, in Step S20, the recognition scores of the plurality of parts of the subject are newly calculated.

[0096] Here, the first predetermined number of frames in Step S9 and the second predetermined number of frames in Step S21 may be equal to or different from each other. For the purpose of description, it is assumed that the first predetermined number of frames and the second predetermined number of frames are different from each other.

[0097] In a case in which it is determined in Step S21 that the recognition scores have been calculated for the second predetermined number of frames of ultrasound images, the process proceeds to Step S22. In Step S22, the image recognition unit 9 averages the recognition scores of the determination part that ranks first in the determination order which have been calculated for the second predetermined number of frames of ultrasound

images in Step S20. As such, the image recognition unit 9 calculates the mean value of the recognition scores of the determination part as the recognition score for determining the imaging part. In this case, it is preferable that a plurality of ultrasound images used to recognize the determination part are continuous in time series.

[0098] Then, in Step S14, the apparatus control unit 14 determines whether the recognition score for determination calculated in Step S22 is greater than the determination threshold value. In a case in which it is determined in Step S14 that the recognition score for determination is equal to or less than the determination threshold value, it is difficult to decide the determination part with respect to the imaging part and the process proceeds to Step S15. In a case in which it is determined in Step S15 that the threshold value determination for the recognition scores of all of the plurality of parts of the subject has not been performed in Step S14, the determination part is updated in Step S16 and the process returns to Step S22.

[0099] In a case in which the process returns to Step S22, the recognition score for determination is calculated for the part that ranks second in the determination order. As such, as long as the recognition score for determination is equal to or less than the determination threshold value in Step S14, Steps S22 to S16 are repeated. In a case in which it is determined in Step S14 that the recognition score for determination is greater than the determination threshold value, the process proceeds to Step S17 and the imaging part is decided. Then, the part determination operation illustrated in the flowchart of Fig. 7 ends.

[0100] As such, since the recognition score for part determination is calculated from the recognition scores calculated for a plurality of ultrasound images, it is possible to improve the accuracy of determining the imaging part. For example, even in a case in which a part of the subject included in some of the ultrasound images acquired in Step S12 is not sufficiently clear as the image recognition target, the accuracy of deciding the imaging part is improved.

[0101] In the above description, in a case in which the recognition score for determining the imaging part is calculated in Step S22, the recognition scores for the second predetermined number of frames of ultrasound images acquired in Step S12 are used. However, the recognition score for determining the imaging part may be calculated in Step S22 on the basis of both the recognition scores calculated in Step S20 and the recognition scores for the first predetermined number of frames of ultrasound images. That is, the second predetermined number of frames may be the sum of the first predetermined number of frames and the number of frames of ultrasound images acquired in Step S12.

[0102] At that time, in a case in which the second predetermined number of frames is equal to or less than the first predetermined number of frames, that is, in a case in which the number of recognition scores of a plurality

of parts of the subject required to calculate the recognition score for determining the imaging part in Step S22 is equal to or less than the number of recognition scores required to calculate the index values in Step S10, Step S12, Step S20, and Step S21 can be omitted. Therefore, it is possible to further reduce the time required to determine the imaging part.

Embodiment 4

[0103] In the part determination operations according to Embodiments 1 and 3 illustrated in Figs. 5 and 7, the determination order in which the threshold value determination is performed for the recognition score of each part of the subject is decided on the basis of the index values of a plurality of parts of the subject. However, at that time, the parts to be determined with respect to the imaging part may be narrowed down.

[0104] Fig. 8 illustrates the configuration of an ultrasound diagnostic apparatus 21 according to Embodiment 4. The ultrasound diagnostic apparatus 21 according to Embodiment 4 is the same as the ultrasound diagnostic apparatus 1 according to Embodiment 1 illustrated in Fig. 1 except that it includes a part narrowing-down unit 22. Therefore, components other than the part narrowing-down unit 22 are denoted by the same reference numerals and the detailed description thereof will not be repeated.

[0105] In the ultrasound diagnostic apparatus 21 according to Embodiment 4, the part narrowing-down unit 22 is connected to the index value calculation unit 10. The part narrowing-down unit 22 is connected to the order decision unit 11. In addition, the apparatus control unit 14 is connected to the part narrowing-down unit 22.

[0106] The part narrowing-down unit 22 narrows down the parts to be determined with respect to the imaging part whose image is currently captured among a plurality of parts of the subject on the basis of the index values of the plurality of parts of the subject calculated by the index value calculation unit 10. At that time, the part narrowing-down unit 22 narrows down only the parts whose index values are greater than a predetermined value among the plurality of parts of the subject to the determination parts.

[0107] Fig. 9 is a flowchart illustrating a part determination operation of the ultrasound diagnostic apparatus 21 according to Embodiment 4. The flowchart illustrated in Fig. 9 is the same as the flowchart illustrated in Fig. 5 except that Step S23 substitutes Step S11 in the flowchart according to Embodiment 1 illustrated in Fig. 5. Therefore, the detailed description of the same steps as those in the flowchart of Fig. 5 will not be repeated.

[0108] In a case in which the part determination operation of the ultrasound diagnostic apparatus 21 according to Embodiment 4 starts, the recognition scores of a plurality of parts of the subject are calculated for a predetermined number of frames of ultrasound images in Steps S7 to S9. Then, in Step S10, index values are calculated

on the basis of the recognition scores.

[0109] Then, in Step S23, first, the part narrowing-down unit 22 narrows down the parts to be determined with respect to the imaging part whose image is currently captured on the basis of the index values of the plurality of parts of the subject calculated in Step S10. That is, the part narrowing-down unit 22 narrows down only the parts whose index values calculated in Step S10 are greater than a predetermined value among the plurality of parts of the subject to the determination parts. Then, the order decision unit 11 decides the determination order of a plurality of parts narrowed down by the part narrowing-down unit 22 such that the part with a larger index value ranks higher.

[0110] Then, in Steps S12 and S13, an ultrasound image is newly acquired and only the recognition score of a part that ranks first in the determination order is calculated. Then, in Steps S14 to S16, it is determined whether the recognition score is greater than the determination threshold value and the determination part is updated. In Step S16, the determination part is continuously updated. As a result, in a case in which it is determined in Step S15 that the threshold value determination for the recognition scores of all of the plurality of parts narrowed down in Step S20 has been completed in Step S14, it is determined that it is difficult to decide the part included in the ultrasound image acquired in Step S12 to be any of the plurality of parts of the subject and the process returns to Step S8. Then, the part determination operation starts again.

[0111] In a case in which it is determined in Step S14 that the recognition score of the part calculated in Step S13 is greater than the threshold value, the process proceeds to Step S17. In a case in which the part to be determined with respect to the imaging part whose image is currently captured is decided in Step S17, the part determination operation ends.

[0112] As described above, in the part determination operation according to Embodiment 4, after the parts to be determined with respect to the imaging part whose image is currently captured are narrowed down, the determination order is decided. Therefore, the calculation load of the ultrasound diagnostic apparatus 21 for deciding the determination order is reduced. In addition, since the number of determination parts is narrowed down in Step S20, it is possible to reduce the number of times the determination part is updated in Step S16 in a case in which Steps S13 to S16 are repeated. Therefore, according to the ultrasound diagnostic apparatus 21 of Embodiment 4, it is possible to reduce the calculation load of the ultrasound diagnostic apparatus 21 and to reduce the time required to determine the imaging part.

[0113] The ultrasound diagnostic apparatuses according to the embodiments of the invention have been described in detail above. However, the invention is not limited to the above-mentioned examples and various modifications and changes of the invention may be made without departing from the scope and spirit of the inven-

tion. In addition, a plurality of embodiments described above may be appropriately combined with each other.

Explanation of References

[0114]

- 1, 21: ultrasound diagnostic apparatus
- 2: ultrasound probe
- 2A: transducer array
- 3: image acquisition unit
- 4: receiving unit
- 5: transmitting unit
- 6: image generation unit
- 7: display control unit
- 8: display unit
- 9: image recognition unit
- 10: index value calculation unit
- 11: order decision unit
- 12: part determination unit
- 13: probe state detection unit
- 14: apparatus control unit
- 15: operation unit
- 16: storage unit
- 17: amplification unit
- 18: A/D conversion unit
- 19: B-mode processing unit
- 20: image processing unit
- 22: part narrowing-down unit

Claims

1. An ultrasound diagnostic apparatus comprising:

- an image acquisition unit that transmits an ultrasound beam from an ultrasound probe to a subject to generate an ultrasound image;
- an image recognition unit that performs image recognition for the ultrasound image generated by the image acquisition unit to calculate recognition scores of a plurality of parts of the subject;
- an index value calculation unit that calculates index values of the plurality of parts on the basis of the recognition scores of the plurality of parts calculated for a predetermined number of ultrasound images;
- an order decision unit that decides a determination order in which part determination is performed for the plurality of parts on the basis of the index values; and
- a part determination unit that determines an imaging part of the subject on the basis of the recognition scores calculated by the image recognition unit according to the determination order.

2. The ultrasound diagnostic apparatus according to claim 1,

wherein the index value calculation unit uses, as the index values of the plurality of parts, recognition scores of the plurality of parts calculated by the image recognition unit for a latest ultrasound image acquired by the image acquisition unit.

3. The ultrasound diagnostic apparatus according to claim 1, wherein the index value calculation unit calculates the index values of the plurality of parts on the basis of recognition scores of the plurality of parts calculated by the image recognition unit for each of a plurality of ultrasound images which are continuously acquired in time series and include a latest ultrasound image acquired by the image acquisition unit.

4. The ultrasound diagnostic apparatus according to claim 3, wherein the index value calculation unit uses mean values or medians of the recognition scores of the plurality of parts calculated for the plurality of ultrasound images as the index values of the plurality of parts.

5. The ultrasound diagnostic apparatus according to claim 3, wherein the index value calculation unit uses maximum values or minimum values of the recognition scores of the plurality of parts calculated for the plurality of ultrasound images as the index values of the plurality of parts.

6. The ultrasound diagnostic apparatus according to claim 3, wherein the index value calculation unit calculates weighted mean values of the recognition scores of the plurality of parts by giving a larger weight to an ultrasound image more recently acquired by the image acquisition unit among the plurality of ultrasound images and uses the weighted mean values as the index values of the plurality of parts.

7. The ultrasound diagnostic apparatus according to claim 3, wherein the index value calculation unit gives ranking scores to the plurality of parts for each of the plurality of ultrasound images such that the part with a higher recognition score has a higher ranking score and uses sums of the ranking scores of the plurality of parts for the plurality of ultrasound images as the index values of the plurality of parts.

8. The ultrasound diagnostic apparatus according to claim 3, wherein the index value calculation unit has a threshold value of the recognition score and uses the number of recognition scores greater than the threshold value among the recognition scores of the

plurality of parts calculated for the plurality of ultrasound images as the index value of each of the plurality of parts.

9. The ultrasound diagnostic apparatus according to any one of claims 3 to 8, wherein, in a case in which there are the same index values among the calculated index values of the plurality of parts, the index value calculation unit calculates the index values again, using an ultrasound image group which includes the latest ultrasound image and consists of ultrasound images which are continuous in time series and whose number is less than the number of the ultrasound images used to calculate the index values.

10. The ultrasound diagnostic apparatus according to any one of claims 3 to 8, wherein, in a case in which there are the same index values among the calculated index values of the plurality of parts, the index value calculation unit calculates the index values again, using an ultrasound image group consisting of a plurality of ultrasound images which are continuous in time series and are acquired by the image acquisition unit before the latest ultrasound image in time series.

11. The ultrasound diagnostic apparatus according to any one of claims 1 to 10, further comprising: a probe state detection unit that detects a change in the imaging part caused by movement of the ultrasound probe, wherein, after the probe state detection unit detects the change in the imaging part, the index value calculation unit starts to calculate the index value.

12. The ultrasound diagnostic apparatus according to any one of claims 1 to 11, wherein the order decision unit decides the determination order such that the part with a larger index value ranks higher.

13. A method for controlling an ultrasound diagnostic apparatus, the method comprising: transmitting an ultrasound beam from an ultrasound probe to a subject to generate an ultrasound image; performing image recognition for the ultrasound image to calculate recognition scores of a plurality of parts of the subject; calculating index values of the plurality of parts on the basis of the recognition scores of the plurality of parts calculated for a predetermined number of ultrasound images; deciding a determination order in which part de-

termination is performed for the plurality of parts on the basis of the index values; and determining an imaging part of the subject on the basis of the recognition scores calculated according to the determination order.

14. A program that controls an ultrasound diagnostic apparatus and causes a computer to perform: a step of transmitting an ultrasound beam from an ultrasound probe to a subject to generate an ultrasound image; a step of performing image recognition for the ultrasound image to calculate recognition scores of a plurality of parts of the subject; a step of calculating index values of the plurality of parts on the basis of the recognition scores of the plurality of parts calculated for a predetermined number of ultrasound images; a step of deciding a determination order in which part determination is performed for the plurality of parts on the basis of the index values; and a step of determining an imaging part of the subject on the basis of the recognition scores calculated according to the determination order.

FIG. 1

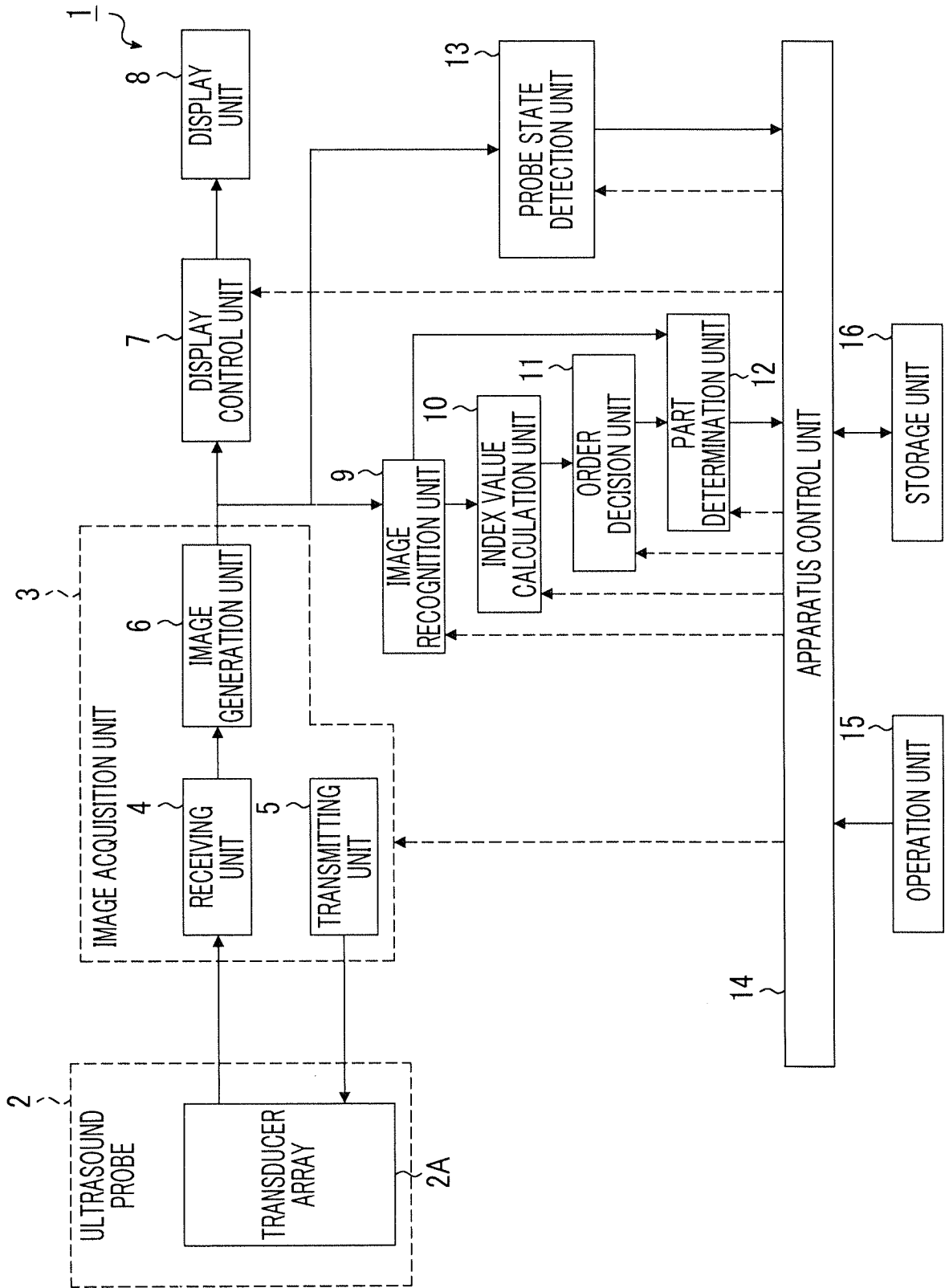

FIG. 2

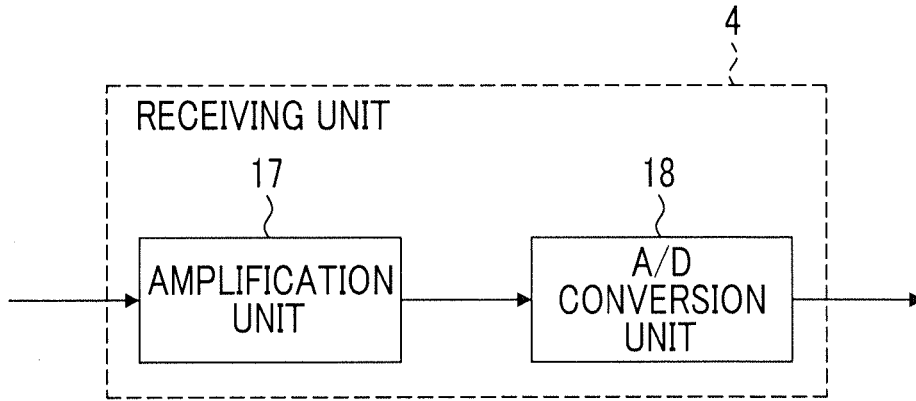

FIG. 3

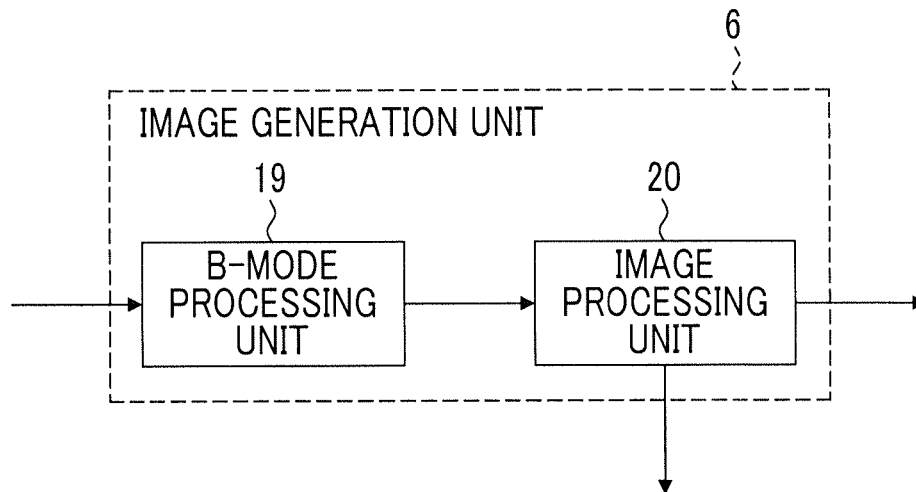

FIG. 4

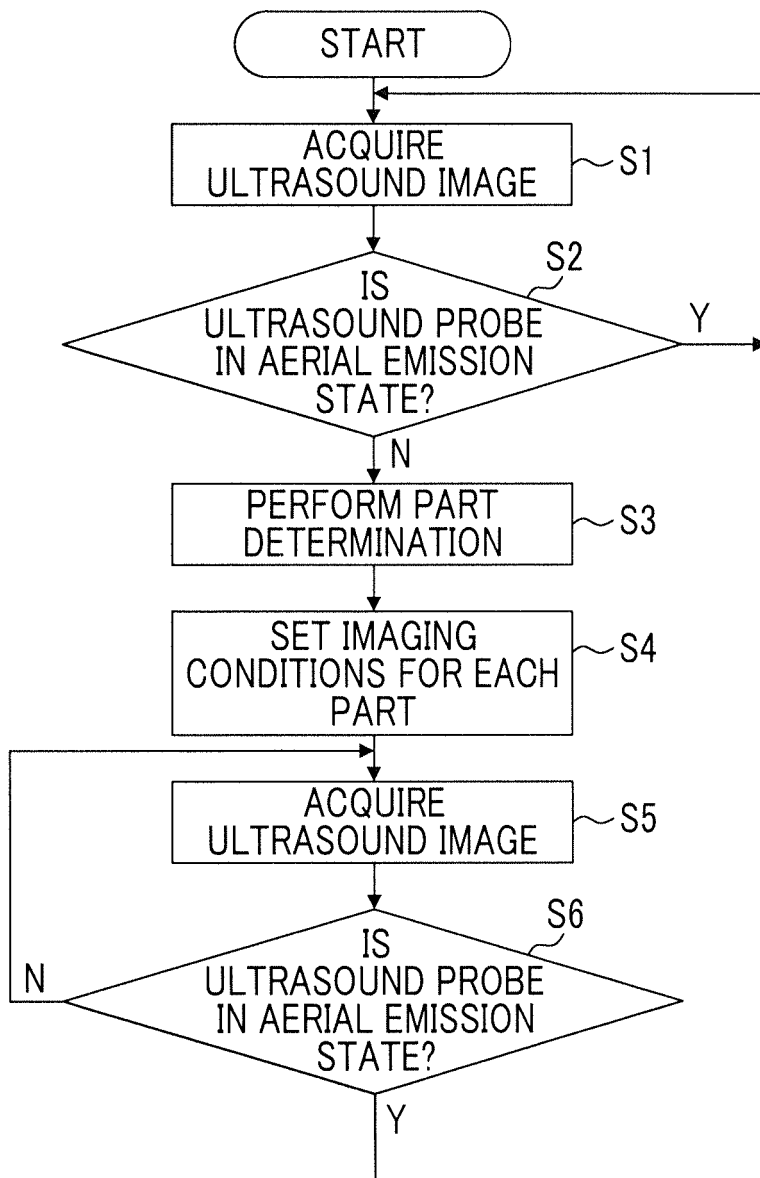

FIG. 5

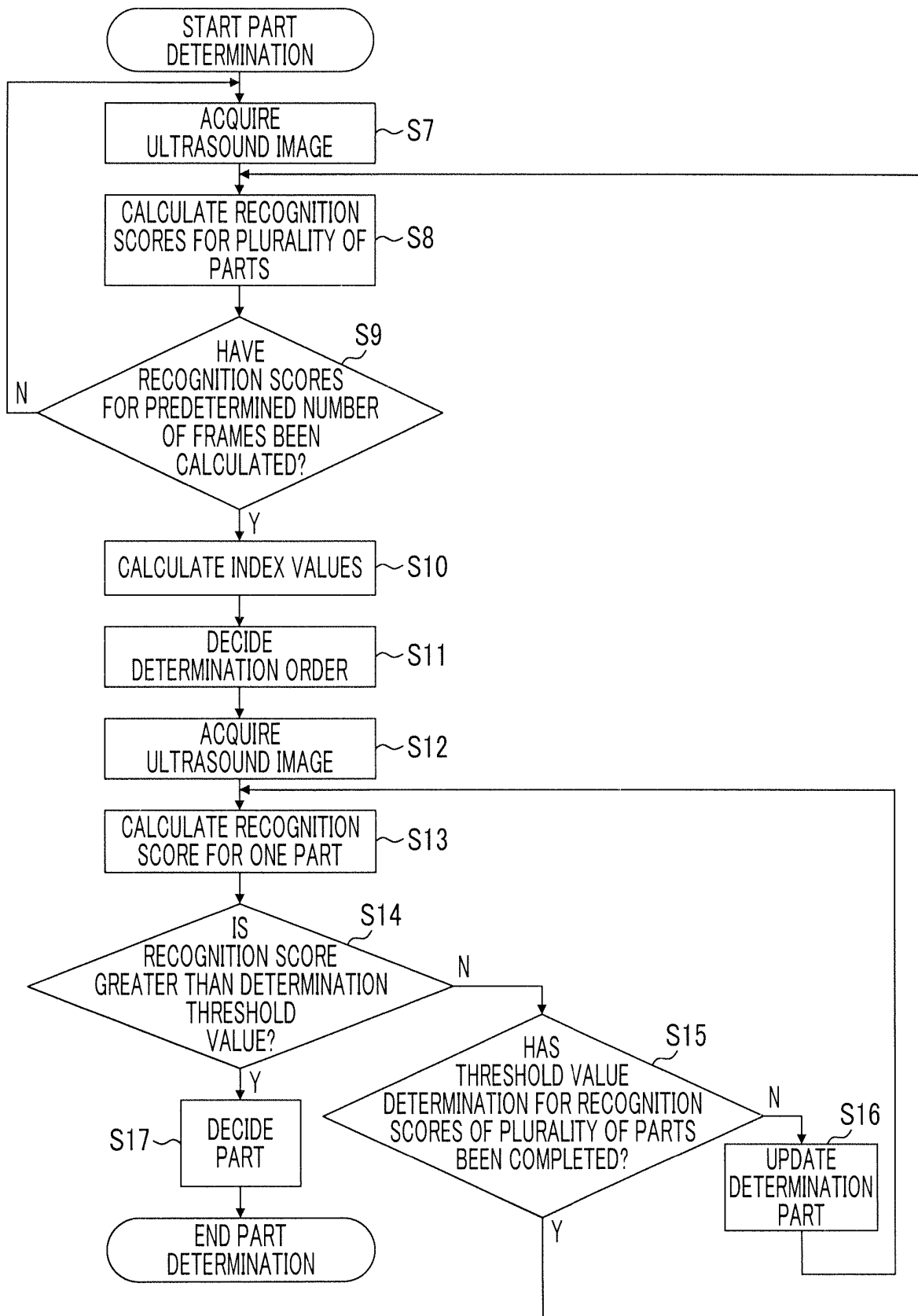

FIG. 6

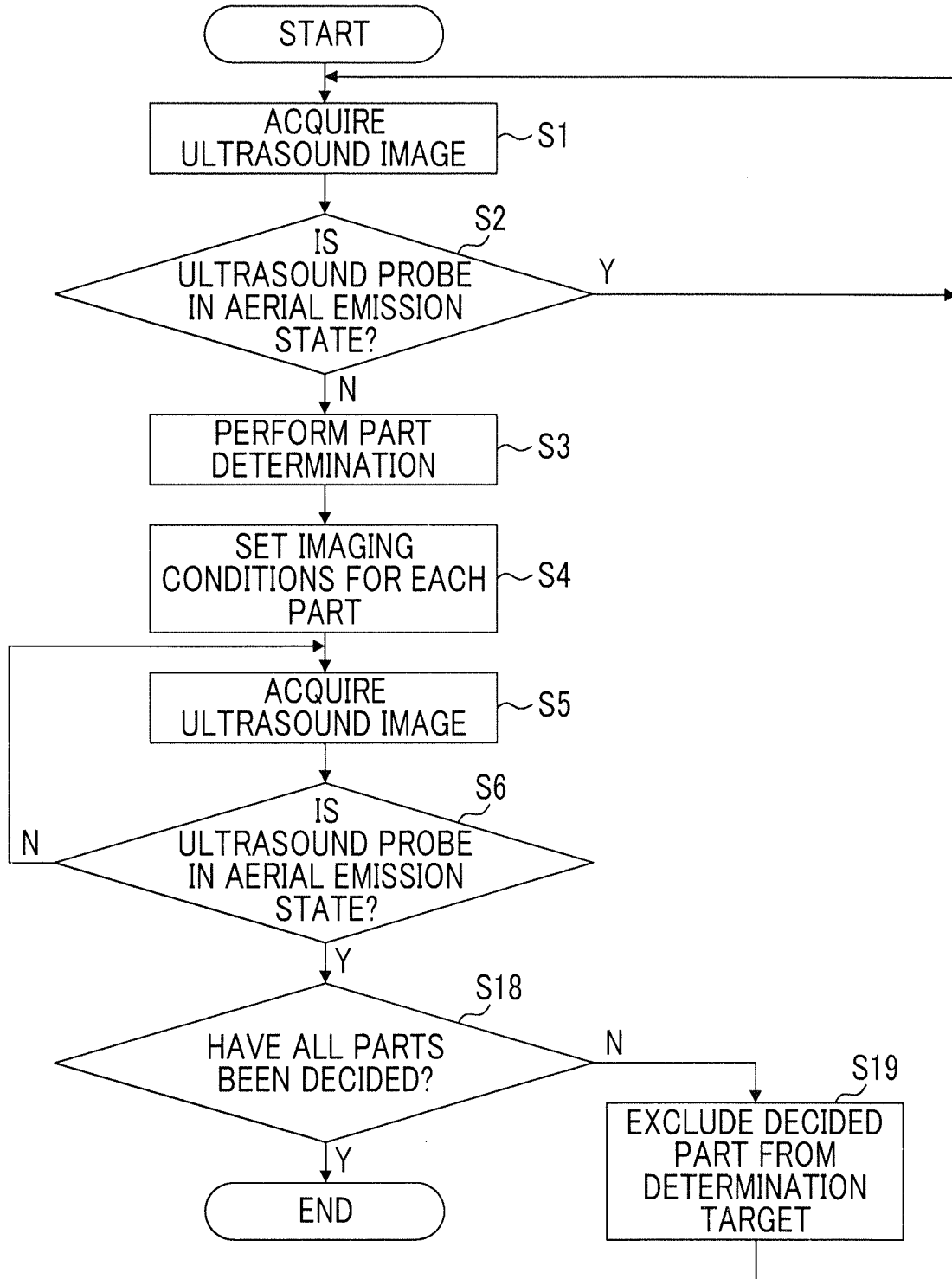

FIG. 7

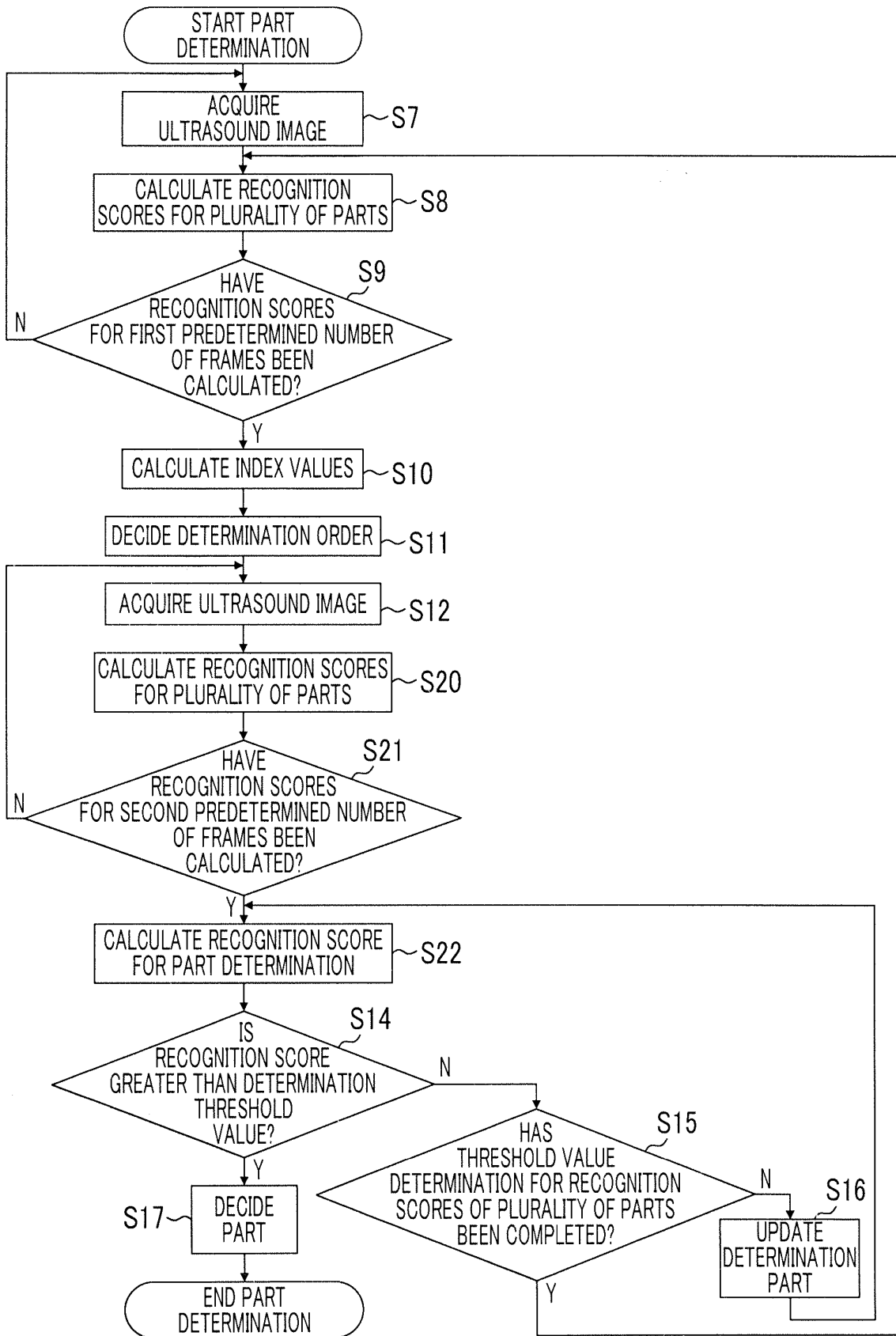

FIG. 8

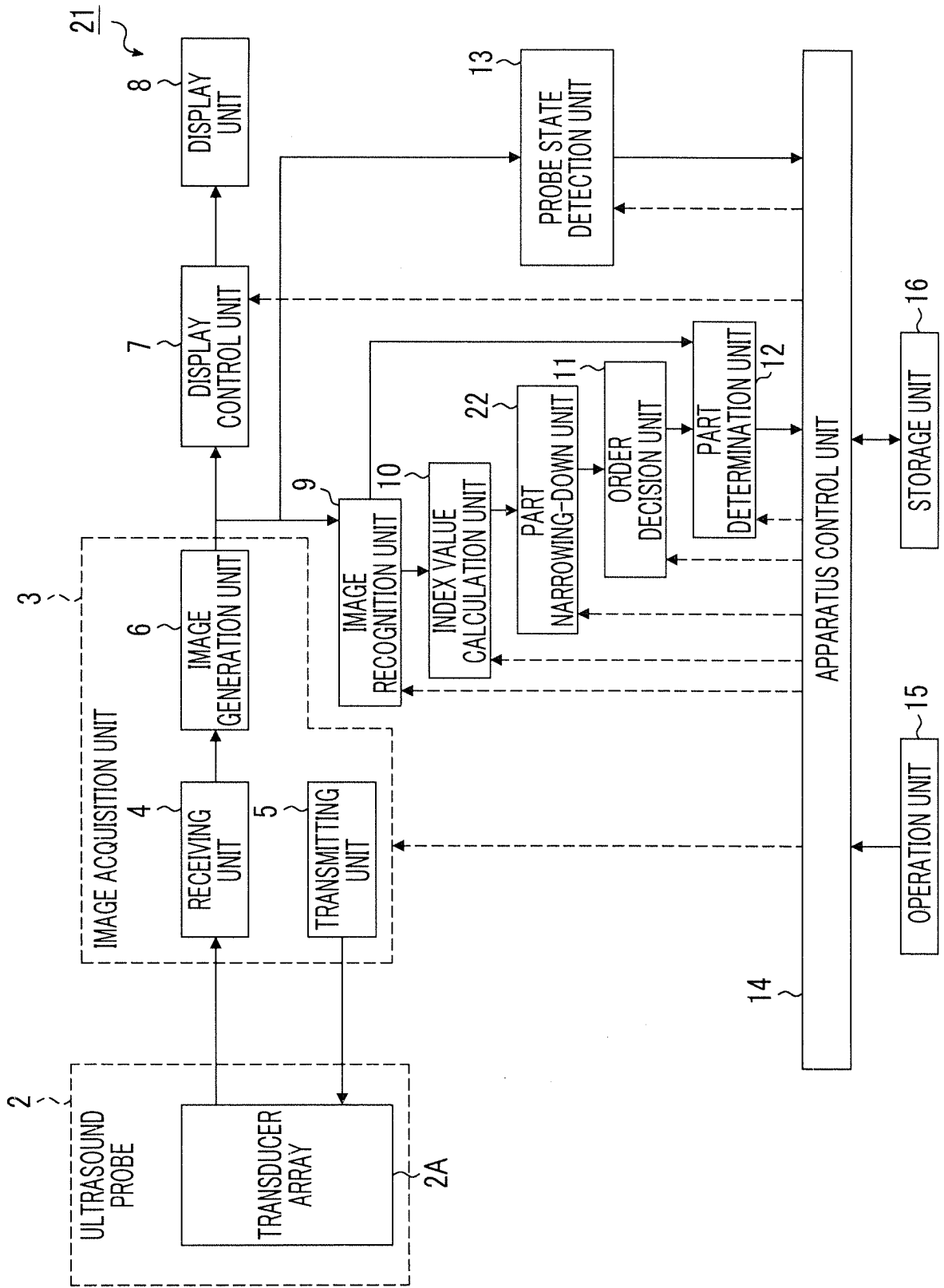
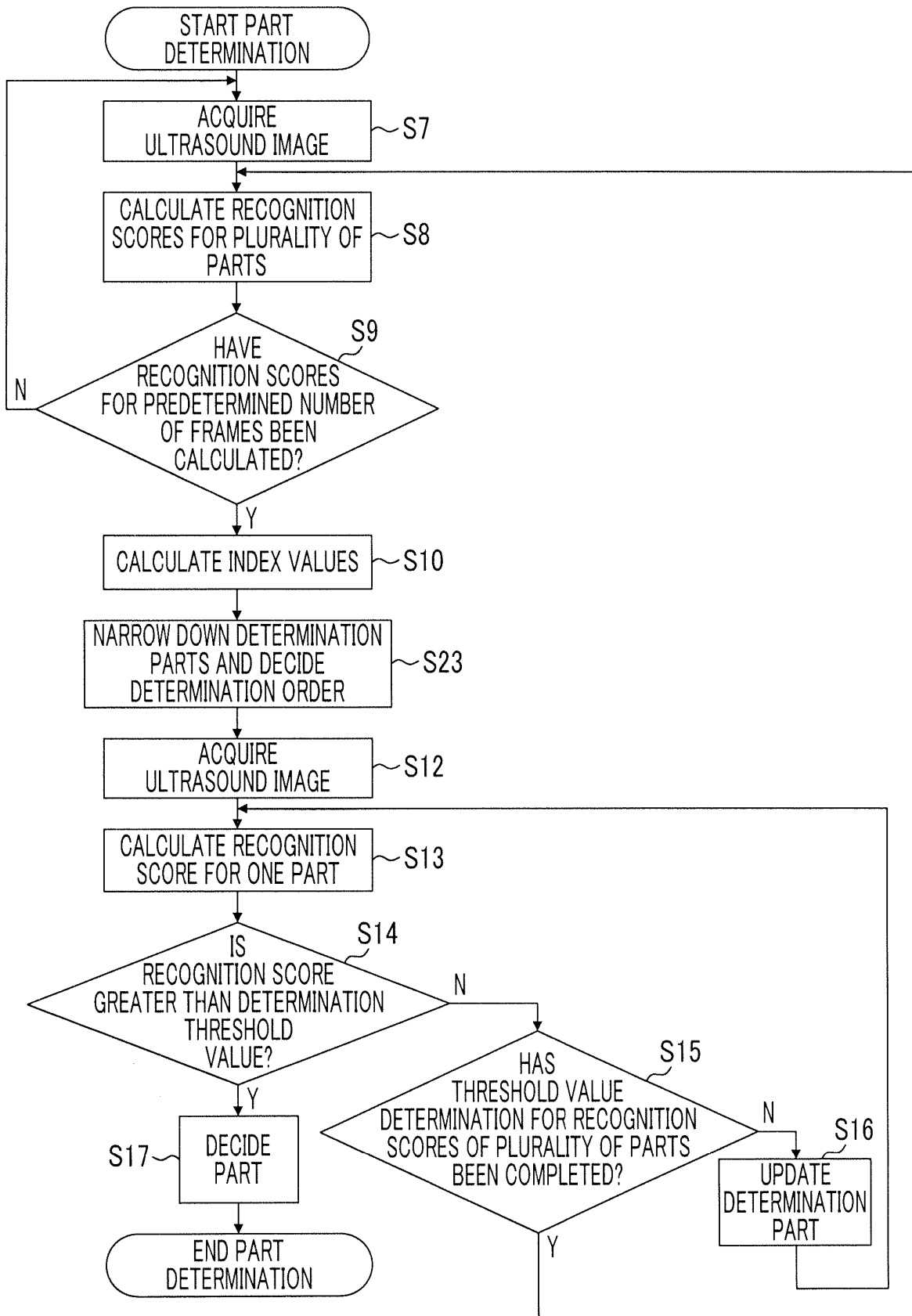

FIG. 9



INTERNATIONAL SEARCH REPORT

International application No.
PCT/JP2018/001326

5

A. CLASSIFICATION OF SUBJECT MATTER
Int.Cl. A61B8/14 (2006.01) i

According to International Patent Classification (IPC) or to both national classification and IPC

10

B. FIELDS SEARCHED

Minimum documentation searched (classification system followed by classification symbols)
Int.Cl. A61B8/00-8/15

15

Documentation searched other than minimum documentation to the extent that such documents are included in the fields searched

Published examined utility model applications of Japan	1922-1996
Published unexamined utility model applications of Japan	1971-2018
Registered utility model specifications of Japan	1996-2018
Published registered utility model applications of Japan	1994-2018

20

Electronic data base consulted during the international search (name of data base and, where practicable, search terms used)

25

C. DOCUMENTS CONSIDERED TO BE RELEVANT

25

Category*	Citation of document, with indication, where appropriate, of the relevant passages	Relevant to claim No.
A	JP 4-224738 A (YOKOGAWA MEDICAL SYST LTD.) 14 August 1992, paragraphs [0004]-[0006] (Family: none)	1-14
A	JP 2010-259662 A (SHIMADZU CORPORATION) 18 November 2010, paragraphs [0010]-[0012] (Family: none)	1-14

30

35

40

Further documents are listed in the continuation of Box C. See patent family annex.

45

* Special categories of cited documents:

"A" document defining the general state of the art which is not considered to be of particular relevance	"T" later document published after the international filing date or priority date and not in conflict with the application but cited to understand the principle or theory underlying the invention
"E" earlier application or patent but published on or after the international filing date	"X" document of particular relevance; the claimed invention cannot be considered novel or cannot be considered to involve an inventive step when the document is taken alone
"L" document which may throw doubts on priority claim(s) or which is cited to establish the publication date of another citation or other special reason (as specified)	"Y" document of particular relevance; the claimed invention cannot be considered to involve an inventive step when the document is combined with one or more other such documents, such combination being obvious to a person skilled in the art
"O" document referring to an oral disclosure, use, exhibition or other means	"&" document member of the same patent family
"P" document published prior to the international filing date but later than the priority date claimed	

50

Date of the actual completion of the international search 05.04.2018	Date of mailing of the international search report 17.04.2018
---	--

55

Name and mailing address of the ISA/ Japan Patent Office 3-4-3, Kasumigaseki, Chiyoda-ku, Tokyo 100-8915, Japan	Authorized officer Telephone No.
--	---

REFERENCES CITED IN THE DESCRIPTION

This list of references cited by the applicant is for the reader's convenience only. It does not form part of the European patent document. Even though great care has been taken in compiling the references, errors or omissions cannot be excluded and the EPO disclaims all liability in this regard.

Patent documents cited in the description

- JP 4224738 A [0004] [0005]
- JP H04224738 A [0004] [0005]

专利名称(译)	超声诊断设备，超声诊断控制方法和超声诊断控制程序		
公开(公告)号	EP3578109A1	公开(公告)日	2019-12-11
申请号	EP2018748229	申请日	2018-01-18
[标]申请(专利权)人(译)	富士胶片株式会社		
申请(专利权)人(译)	富士胶片株式会社		
当前申请(专利权)人(译)	富士胶片株式会社		
[标]发明人	EBATA TETSUROU		
发明人	EBATA TETSUROU		
IPC分类号	A61B8/14		
CPC分类号	A61B8/429 A61B8/5223 A61B8/54 A61B8/585 A61H23/0245 G06K9/6217 G06K2209/05 G16H50/30 G06K9/00 G06K9/6267 G06K9/6277 A61B8/5207 A61B8/5292		
优先权	2017016590 2017-02-01 JP		
其他公开文献	EP3578109A4		
外部链接	Espacenet		

摘要(译)

超声诊断设备1包括：生成超声图像的图像获取单元3；对超声图像进行图像识别以计算识别分数的图像识别单元9；计算多个部分的指标值的指标值计算单元10。基于针对预定数量的超声图像计算的识别分数，顺序确定单元11和部分确定单元，顺序确定单元11确定确定顺序，在该确定顺序中，对多个部分进行部分确定。图12是根据根据确定顺序计算出的识别分数来确定被摄体的摄像部位的图。

