

(19)



(11)

EP 2 371 290 B1

(12)

EUROPEAN PATENT SPECIFICATION

(45) Date of publication and mention of the grant of the patent:
01.07.2020 Bulletin 2020/27

(51) Int Cl.:
A61B 8/00 (2006.01)

(21) Application number: **11160314.8**

(22) Date of filing: **29.03.2011**

(54) **Ultrasonic diagnostic apparatus, ultrasonic image processing apparatus, and medical diagnostic imaging apparatus**

Ultraschalldiagnosevorrichtung, Ultraschallbildverarbeitungsvorrichtung und medizinische Diagnoseabbildungsvorrichtung

Appareil de diagnostic à ultrasons, appareil de traitement d'images à ultrasons et appareil d'imagerie pour le diagnostic médical

(84) Designated Contracting States:
AL AT BE BG CH CY CZ DE DK EE ES FI FR GB GR HR HU IE IS IT LI LT LU LV MC MK MT NL NO PL PT RO RS SE SI SK SM TR

(30) Priority: **30.03.2010 JP 2010078909**

(43) Date of publication of application:
05.10.2011 Bulletin 2011/40

(73) Proprietor: **Toshiba Medical Systems Corporation Otawara-Shi, Tochigi-Ken 324-8550 (JP)**

(72) Inventors:
• **Yoshida, Tetsuya Otawara-Shi, Tochigi 324-8550 (JP)**

• **Kuga, Itsuki Otawara-Shi, Tochigi 324-8550 (JP)**

(74) Representative: **Kramer Barske Schmidtchen Patentanwälte PartG mbB European Patent Attorneys Landsberger Strasse 300 80687 München (DE)**

(56) References cited:
WO-A1-2005/054898 WO-A1-2009/083557
WO-A1-2009/093211 WO-A2-2006/090309
WO-A2-2006/114658 US-A1- 2002 029 120
US-A1- 2005 203 395 US-A1- 2010 053 209

EP 2 371 290 B1

Note: Within nine months of the publication of the mention of the grant of the European patent in the European Patent Bulletin, any person may give notice to the European Patent Office of opposition to that patent, in accordance with the Implementing Regulations. Notice of opposition shall not be deemed to have been filed until the opposition fee has been paid. (Art. 99(1) European Patent Convention).

Description

FIELD

[0001] Embodiments described herein relate generally to an ultrasonic diagnostic apparatus, an ultrasonic image processing apparatus, and a medical diagnostic imaging apparatus.

BACKGROUND

[0002] The present embodiments relate to an ultrasonic diagnostic apparatus and others that can three-dimensionally visualize a temporal change in blood flow dynamic state in, e.g., an organ which is a diagnostic imaging target by using microbubbles as an ultrasonic contrast agent, and more particularly to an ultrasonic diagnostic apparatus, an ultrasonic image processing apparatus, and medical diagnostic imaging apparatus that can easily observe information of, e.g., a dynamic change in blood flow or fine angioarchitectonic with high visibility.

[0003] Ultrasonic diagnostic imaging is easy to use since a state of heartbeat or fetal movement can be obtained in real-time display by a simple operation, i.e., just applying an ultrasonic probe from a surface of a body, examinations can be repeatedly conducted because of high safety, a system scale is smaller than that of any other diagnostic device of X-ray, CT, or MRI, and bedside examinations can be also easily performed.

[0004] Further, the ultrasonic diagnosis has no influence of radiation exposure as different from X-rays, and it can be used in obstetrics, home medical care, and others. Particularly, in recent years, an agitation probe (a probe that enables ultrasonic scan of a three-dimensional region by mechanically agitating a row of one-dimensionally aligned ultrasonic oscillators) or a two-dimensional array probe (a probe that enables ultrasonic scan of a three-dimensional region by a row of ultrasonic oscillators aligned in a matrix form) can be utilized to perform real-time three-dimensional scan (which is also called "four-dimensional scan").

[0005] WO2005/054898 discloses an image processing apparatus for ultrasound tissue perfusion images comprising a volume data generation unit configured to generate first volume data being data of a luminance value representing a spatial density of a contrast agent in each time phase in an analysis period, second volume data being generated from the first volume data and indicating contrast agent temporal information with respect to the luminance value about the analysis period and third volume data being generated from the first volume data and indicating a contrast agent characteristic amount with respect to the luminance value at each position in the three-dimensional region in the analysis period and an image generation unit configured to generate a projected image by executing projection processing using the second volume data and the third volume data.

[0006] Furthermore, in recent years, an intravenous

administration type ultrasonic contrast agent has been productized. In the ultrasonic diagnostic imaging, performing contrast imaging using such a contrast agent enables acquiring various kinds of information. For example, in case of a primary liver cancer, a differential diagnosis about benign and malignancy and others can be carried out by complementarily using blood flow information of an arterial phase or blood flow information of a portal phase. Moreover, when the contrast imaging is performed after an RFA treatment, an ablated area is not stained, and hence this imaging is also applied to an effect judgment. Additionally, an imaging method for intravenously injecting an ultrasonic contrast agent to enhance a blood flow single in an examination of, e.g., a heart and a liver and thereby evaluating a blood flow dynamic state has been also suggested. A replenishment method and micro flow imaging are representative examples of an imaging method for evaluating the blood flow dynamic state.

[0007] The replenishment method is a technique by which characteristics that air bubbles of a contrast agent collapse are exploited, (a) a dynamic state of the air bubbles filling a scan cross section is observed under radiation of a low acoustic pressure, (b) the radiated acoustic pressure is switched to a high acoustic pressure to collapse the air bubbles in the cross section (in an irradiated volume in a precise sense), and (c) a state of the air bubbles that again flow into the cross section is observed.

[0008] In general, the contrast imaging is characterized in that a fine blood flow that cannot be visualized by, e.g., color Doppler can be visualized. On the other hand, only a small quantity of bubbles are present in the fine blood flow. Therefore, staining is non-steadily effected. The micro flow imaging is a technique that characteristics of such contrast imaging and a contrast agent are utilized and non-steadily visualized bubbles are temporally superimposed and displayed to more clearly visualize a fine blood flow configuration. When executing the micro flow imaging, there is a restriction that a patient must hold his/her breath for a fixed time and an examiner such as an operator must fix a probe. As a technology that alleviates this restriction, a technology that corrects movement of a target region by image processing has been also suggested (see, e.g., Patent Document 2).

[0009] In such contrast imaging, for example, dynamic information such as a staining start time phase (namely, which corresponds to a bubble arrival time), a time phase that staining achieves a peak (a peak time), a Wash-In time defined by an arrival time - a peak time of bubbles, a Wash-Out time defined by a time at which the bubbles flow out to a vein - the peak time is acquired spatially (i.e., at each position). It may be preferable for these pieces of dynamic information to be observed as moving images in some cases. For example, in case of a liver, a tumor is nourished with arterial blood, and a normal parenchyma is nourished with portal blood. Therefore, effecting observation using moving images enables putting a clock time that the contrast agent reaches a tumor re-

gion ahead of those in peripheral regions, thereby visually confirming how the tumor begins to be stained earlier than the other regions.

[0010] On the other hand, in the observation of moving images of the dynamic information, since a temporal change at each position must be retained in a user's head, it cannot be necessarily said that this observation is objective. Further, there is also a problem that the observation requires a certain amount of time. To solve these problems, a two-dimensional parametric imaging technology that enables observing dynamic information by using one two-dimensional image has been suggested. According to this technology, for example, a maximum value of a temporal change in luminance in each pixel is determined as a peak time, or a threshold value that is not affected by, e.g., noise is provided, a calculation of, e.g., determining a first time at which the threshold value is exceeded as an arrival time is performed to obtain temporal information. Furthermore, a two-dimensional image whose color tone is changed in accordance with each position is displayed based on a value of the obtained temporal information. It is effective to combine this technology with the above-described Micro Flow Imaging or movement correction technology, and utilization at clinical scenes in the future is expected.

[0011] However, in the two-dimensional parametric imaging, since two-dimensional image data (tomographic data) is used, there is a limit in representation of spatial continuity of a blood flow. It is difficult to recognize, e.g., a blood vessel having a configuration in a depth direction. For example, a blood vessel orthogonal to a tomographic image is substantially represented as a dot.

[0012] On the other hand, in case of observing a blood flow dynamic state (a temporal change in blood flow), when a plurality of pieces of volume data having different time phases are observed, the number of dimensions of the observation range increase by one as compared with a conventional diagnosis based on a two-dimensional image (a tomographic image), an observation time increases, and a problem that the construction (storage) of temporal change information also becomes ambiguous in an operator's head occurs.

[0013] Therefore, it can be considered that performing parametric imaging using time-series volume data (four-dimensional parametric imaging) is effective. However, in regard to three-dimensional visualizing method of temporal information such as an arrival time, a method that is effective in clinical practice has not been suggested. That is because simply three-dimensionally carrying out the two-dimensional parametric imaging cannot appropriately process temporal information concerning a depth direction. Particularly, in recent years, a contrast imaging function has been introduced into ultrasonic diagnostic apparatuses that enable four-dimensional scan. Therefore, establishing a four-dimensional parametric imaging technique to enable three-dimensional observation of a dynamic blood flow state has a high clinical value and is strongly demanded.

[0014] In view of the above-described problems, it is an object of the present invention to provide an ultrasonic diagnostic apparatus, an ultrasonic image processing apparatus, and a medical diagnostic imaging apparatus that enable easily observing information such as a dynamic blood flow change or fine angioarchitectonic with high visibility based on the four-dimensional parametric imaging.

[0015] This object is achieved by a medical diagnostic imaging apparatus according to claim 2, an ultrasonic diagnostic apparatus according to claim 3, and an ultrasonic image processing apparatus according to claim 4 or 9, each comprising an image processing apparatus according to claim 1.

BRIEF DESCRIPTION OF THE DRAWINGS

[0016]

FIG. 1 is a block diagram of an ultrasonic diagnostic apparatus 1 according to this embodiment;

FIG. 2 is a flowchart showing a flow of processing based on this four-dimensional parametric imaging function (four-dimensional parametric imaging processing);

FIG. 3 is a view conceptually showing first volume data associated with each time phase k ($k=1, 2, \dots, n$) in a predetermined period;

FIG. 4 is a view showing an example of a TIC in an analysis period of a given voxel;

FIG. 5 is a view for explaining second volume data generation processing using the plurality of pieces of first volume data associated with respective time phases in the analysis period;

FIG. 6 is a view for explaining third volume data generation processing using the plurality of pieces of first volume data associated with the respective time phases in the analysis period;

FIG. 7 is a view for explaining projection processing using second and third volume data;

FIG. 8 is a view showing an example of a color map used for generation of a projected image using the second and third volume data;

FIG. 9 is a view for explaining assignment processing concerning a depth direction of contrast agent temporal information;

FIG. 10 is a view for explaining the assignment processing concerning the depth direction of the contrast agent temporal information;

FIG. 11 is a view for explaining the assignment processing concerning the depth direction of the contrast agent temporal information;

FIG. 12 is a view for explaining an example when the first, second, or third volume data is divided to generate a plurality of projection regions;

FIG. 13 is a view for explaining another example when the first, second, or third volume data is divided to generate a plurality of projection regions; and

FIG. 14 is a view for explaining still another example when the first, second, or third volume data is divided to generate a plurality of projection regions.

DETAILED DESCRIPTION

[0017] In general, according to one embodiment, there is provided an ultrasonic diagnostic apparatus comprising: a data acquisition unit that scans a three-dimensional region in a subject having a contrast agent injected therein by using ultrasonic waves over a predetermined period; a volume data generation unit that generates first volume data in each time phase in an analysis period by using ultrasonic data concerning the three-dimensional region over the analysis period in the predetermined period and also generate second volume data indicative of contrast agent temporal information about the analysis period and third volume data indicative of contrast agent temporal information about the analysis period and third volume data indicative of a contrast agent characteristic amount at each position in the three-dimensional region in the analysis period; and an image generation unit that generates a projected image by using the second volume data and the third volume data.

[0018] An embodiment according to the present embodiment will now be described hereinafter with reference to the drawings. It is to be noted that like reference numerals denote constituent elements having like functions and structures, and overlapping explanations will be given as required.

[0019] FIG. 1 is a block diagram of an ultrasonic diagnostic apparatus 1 according to this embodiment. As shown in the drawing, this ultrasonic diagnostic apparatus 10 comprises an ultrasonic probe 12, an input device 13, a monitor 14, an ultrasonic transmission unit 21, an ultrasonic reception unit 22, a B-mode processing unit 23, a Doppler processing unit 24, an image generation unit 25, an image memory 26, an image combination unit 27, a control processor (a CPU) 28, a memory unit 29, an interface unit 30, and a software storage unit 31. Although the ultrasonic transmission unit 21, the reception unit 22, and others built in an apparatus main body 11 may be constituted of hardware such as integrated circuits, they may be constituted of software programs that are formed as software modules in some cases. A function of each constituent element will now be described.

[0020] The ultrasonic probe 12 generates ultrasonic waves based on a drive signal from the ultrasonic transmission unit 21 and has a plurality of piezoelectric oscillators that convert a reflected wave from a subject into an electrical signal, a matching layer provided to the piezoelectric oscillators, a backing material that prevents the ultrasonic waves from the piezoelectric oscillators from being propagated toward the rear side, and others. When the ultrasonic waves are transmitted to the subject P from the ultrasonic probe 12, the transmitted ultrasonic waves are sequentially reflected on discontinuous surfaces having acoustic impedances of a body tissue and

received by the ultrasonic probe 12 as echo signals. An amplitude of the echo signal is dependent on a difference between the acoustic impedances on the discontinuous surfaces on which the acoustic waves have been reflected. Moreover, echoes in a case that the transmitted ultrasonic pulses are reflected on a surface of a moving blood flow or a cardiac wall are dependent on a velocity component of a mobile object in an ultrasonic wave transmitting direction based on a Doppler effect and undergo frequency shift.

[0021] It is to be noted that the ultrasonic probe 12 included in this ultrasonic apparatus can perform ultrasonic scan with respect to a three-dimensional region of the subject. Therefore, the ultrasonic probe 12 has, e.g., a configuration that the oscillators are mechanically oscillated along a direction orthogonal to their alignment direction to scan a three-dimensional region by ultrasonic waves or a configuration that two-dimensionally aligned two-dimensional oscillation elements are utilized to scan a three-dimensional region by electrical control. When the former configuration is adopted, since the three-dimensional scan of the subject is performed by an oscillation circuit (an oscillation mechanism), a plurality of two-dimensional tomographic images can be automatically acquired by just bringing a probe main body into contact with the subject by an examiner. An accurate distance between cross sections can be also detected based on a controlled oscillation velocity. Additionally, when the latter configuration is adopted, a three-dimensional region can be scanned in principle by ultrasonic waves within a time equal to that required for obtaining two-dimensional tomographic images in a conventional example.

[0022] The input device 13 is connected with the apparatus main body 11 and has a track ball, various kinds of switches, a button, a mouse, a keyboard, and others that are used for fetching various kinds of instructions from an operator, conditions, an instruction to set a region of interest (ROI), various image quality condition setting instructions, and others into the apparatus main body 11.

[0023] The monitor 14 displays morphological information or blood flow information in the body as an image based on a video signal from the image combination unit 27 and others.

[0024] The ultrasonic transmission unit 21 has a trigger generation circuit, a delay circuit, and a pulsar circuit that are not illustrated. The pulsar circuit repeatedly generates a rate pulse used for forming a transmission ultrasonic wave at a predetermined rate frequency f_r Hz (a cycle; $1/f_r$ second). Further, the delay circuit supplies to each rate pulse a delay time required to converge ultrasonic waves in the form of a beam for each channel and determine transmission directional characteristics. Changing this delay information enables arbitrarily adjusting the transmitting direction from the probe oscillator surface. The trigger generation circuit applies a drive pulse to the probe 12 at a timing based on this rate pulse.

[0025] The ultrasonic reception unit 22 has an amplification circuit, an A/D converter, an adder, and others

that are not illustrated. The amplification circuit amplifies an echo signal fetched through the probe 12 in accordance with each channel. The A/D converter provides the amplified echo signal with a delay time required to determine reception directional characteristics, and then the adder performs addition processing. A reflection component from a direction associated with the reception directional characteristics of the echo signal is enhanced by this addition, and a comprehensive beam for ultrasonic wave transmission and reception is formed based on the reception directional characteristic and the transmission directional characteristics.

[0026] The B-mode processing unit 23 receives the echo signal from the ultrasonic reception unit 22 and performs logarithm amplification, envelope detection processing, and others to generate data that a signal intensity is represented by brightness of luminance. At this time, a frequency band to be visualized can be changed by varying a detection frequency. Further, this unit is configured to enable performing respective types of detection processing based on two detection frequencies in parallel with respect to one piece of received data. When this configuration is utilized, a bubble image and a tissue image can be generated from one received signal. It is to be noted that, in case of visualizing bubbles, a second harmonic (a second-order harmonic) is mainly often visualized. Data subjected to processing in this B-mode processing unit 23 is output to the image generation unit 25 and reconfigured as a B-mode image that represents an intensity of a reflected wave as luminance.

[0027] The Doppler processing unit 24 carries out frequency analysis with respect to rate information from the echo signal received from the transmission/reception unit 22, extracts blood flow, tissue, and contrast agent echo components obtained by the Doppler effect, and thereby acquires blood flow information such as an average rate, a variance, power and others at multipoints. The acquired blood flow information is supplied to the image generation unit 24, and an average rate image, a variance image, a power image, and a combination image of these images can be displayed in the monitor 14 in colors.

[0028] The image generation unit 25 converts a scan line signal string for ultrasonic scan into a scan line signal string having a general video format as typified by a television and generates an ultrasonic diagnostic image as a display image. The image display unit 24 has a storage memory for storing image data mounted therein and, for example, an operator can call an image recorded during an examination after a diagnosis. Further, the image generation unit 25 has a function as an image processing device. For example, in case of configuring volume data, a scan line signal string obtained by performing ultrasonic scan with respect to a three-dimensional region or a continuous two-dimensional region is spatially arranged, and coordinate transformation, interpolation processing, and others are executed as required, thereby configuring volume data. The image generation unit 25 utilizes the obtained volume data to execute volume rendering,

processing such as spatial MIP, MPR processing for an arbitrary tomographic image in the volume data based on cutout, micro flow imaging processing, movement correction processing, and others, thus generating a predetermined three-dimensional image. It is to be noted that various kinds of image processing methods and others in this image generation unit 25 may be any one of software techniques and hardware techniques.

[0029] Furthermore, the image generation unit 25 executes predetermined processing based on a later-described four-dimensional parametric imaging function under control of the control processor 28.

[0030] The image memory 26 temporarily stores ultrasonic data corresponding to a plurality of frames or a plurality of volumes.

[0031] The image combination unit 27 combines an image received from the image generation unit 25 with text information, a scale, and others as various parameters to be output to the monitor 14 as a video signal.

[0032] The control processor (a CPU) 28 has a function as an information processing device (a computer) and controls operations of this ultrasonic diagnostic apparatus main body. The control processor 28 reads a program for realizing various image processing methods and a program for realizing the later-described four-dimensional parametric imaging function from the memory unit 29, expands these programs on the software storage unit 31, and executes operations/controls and others concerning various kinds of processing.

[0033] The memory unit 29 stores programs for executing various scan sequences, a dedicated program for realizing the later-described four-dimensional parametric imaging function, a control program for executing image generation and display processing, diagnostic information (a patient ID, a physician's remarks, and others), a diagnostic protocol, transmission/reception conditions, a body mark generation program, and any other data groups. Further, the memory unit 29 is also used for storing images in the image memory 26 as required. The data in the memory unit 29 can be transferred to external peripheral devices through the interface unit 30.

[0034] The interface unit 30 is an interface concerning the input device 13, the network, and a new external memory device (not shown). The interface unit 30 can be utilized to transfer data such as an ultrasonic image, an analysis result, and others obtained by this device to other devices through the network.

(Four-dimensional Parametric Imaging Function)

[0035] The four-dimensional parametric imaging function of this ultrasonic diagnostic apparatus 1 will now be described. According to this function, in the contrast imaging, first volume data that reflects a spatial density of a contrast agent (bubbles) in each time phase in a predetermined period as a signal value is generated by using ultrasonic data concerning the three-dimensional region over the predetermined period. Further, second volume

data indicative of contrast agent temporal information at each position in the three-dimensional region and third volume data indicative of a contrast agent characteristic amount at each position in the three-dimensional region are generated by using the first volume data for each time phase in the predetermined period. Furthermore, the generated second volume data and third volume data are utilized to generate a three-dimensional image that the contrast agent characteristic amount at each position in the three-dimensional region is represented by a luminance value and the contrast agent temporal information is represented by a color tone, and the generated three-dimensional image is displayed in a predetermined conformation.

[0036] It is to be noted that, in the following explanation, a situation where the four-dimensional parametric imaging function is realized by using the ultrasonic diagnostic apparatus will be exemplified for a specific description. However, this function can be also realized by utilizing ultrasonic data acquired in advance by four-dimensional scan using, e.g., an ultrasonic image processing apparatus (or a viewer) based on a medical work station without being restricted to the above example. In such a case, a configuration within a dotted line in FIG. 1 can be adopted. Moreover, in any other medical diagnostic imaging apparatus using a contrast agent (e.g., an X-ray computerized tomography apparatus, a magnetic resonance imaging apparatus, or an X-ray diagnostic apparatus), for example, carrying out substantially the same configuration as that in the dotted line in FIG. 1 enables realizing the four-dimensional parametric imaging function.

[0037] FIG. 2 is a flowchart showing a flow of processing conforming to this four-dimensional parametric imaging function (the four-dimensional parametric imaging processing). Contents of processing executed at each step shown in the flowchart will now be described.

[Input of Patient Information and Selection of transmission/reception Conditions, Scan Sequence, and Others: Step S1]

[0038] Input of patient information and selection of transmission/reception conditions (a field angle, a focal position, a transmission voltage, and others required to determine a size of a scan target region), a scan sequence for scanning a three-dimensional region of a subject by ultrasonic waves over a predetermined period, and others are executed through the operation unit 33 (a step S1). The input or selected various kinds of information/conditions and others are automatically stored in the memory device 29.

[Collection of Volume Data over Predetermined Period: Step S2]

[0039] Then, the transmission/reception control unit 31 determines a three-dimensional region including a predetermined region of a subject (e.g., a blood vessel as a

diagnostic target) as a scan target region and executes real-time three-dimensional ultrasonic scan (four-dimensional scan) over a predetermined period to obtain three-dimensional ultrasonic data associated with each time phase in the predetermined period (a step S2).

[Generation of First Volume Data Representing Spatial Density of Contrast Agent: Step S3]

[0040] Subsequently, the image generation unit 25 executes extraction processing for a harmonic component associated with a signal component from the contrast agent, coordinate transformation, interpolation processing, and others with respect to the acquired three-dimensional ultrasonic data to generate first volume data associated with each of such time phases k ($k=1, 2, \dots, n$) as shown in FIG. 3 (a step S3). In this first volume data, a spatial density (a concentration) of the contrast agent at each time phase is represented by a signal value (a luminance value). Therefore, analyzing the time-series first volume data enables grasping a temporal change in contrast agent density at each position in the three-dimensional region which is a scan target region.

[Generation of Second Volume Data Representing Temporal Information Concerning Contrast Agent: Step S4]

[0041] Then, the image generation unit 25 utilizes the first volume data for each time phase associated with an analysis period (a period that is an analysis target of the four-dimensional parametric imaging in a predetermined period) in the first volume data over the predetermined period to generate second volume data indicative of temporal information concerning the contrast agent (a step S4). Here, the temporal information concerning the contrast agent is, e.g., an arrival time of the contrast agent at each position, a peak time of a signal value (or a luminance value), a Wash-In time, or a Wash-Out time.

[0042] It is to be noted that a start time and an end time of the analysis period can be arbitrarily set by an operation from the input device 13. Further, for example, an ON time of a contrast agent timer, an end time of a burst that destroys bubbles, a time at which bubbles entered (reached) a given target, and others may be detected, and the apparatus may automatically start the analysis period, for example.

[0043] Furthermore, it is assumed that the second volume data is created to be equal to the plurality of first volume data associated with the analysis time in number (in conformity to a time phase of each first volume). However, the present embodiment is not restricted thereto, and the second volume data may be single volume data, for example. The second volume data generated at this step will now be described in accordance with each type of contrast agent temporal information.

(In Case of Determining Contrast Agent Temporal Information as Arrival Time of Contrast Agent)

[0044] The image generation unit 25 first utilizes the plurality of pieces of first volume data associated with the respective time phases in the analysis period to generate a TIC (Time Intensity Curve) in the analysis period about each voxel.

[0045] FIG. 4 is a view showing an example of the TIC in the analysis period about a given voxel. The image generation unit 25 utilizes the TIC in the analysis period about each generated voxel to observe a temporal change in luminance of each voxel and calculates a first time T_{arrived} at which such a preset luminance threshold value as shown in FIG. 4 is exceeded in accordance with each voxel by using a volume rate and a volume number. When this calculated time is determined as a voxel value, the second volume data can be calculated.

[0046] Furthermore, in regard to the first volume data associated with a first time phase in the analysis period, a voxel value of a voxel whose luminance value exceeds the threshold value from the beginning may be determined as zero or no value. That is because a luminance value of such voxel often arises from a signal from a tissue rather than a signal from bubbles.

[0047] When the contrast agent temporal information is an arrival time of the contrast agent in this manner, the same number of pieces of second volume data as the plurality of pieces of first volume data associated with the analysis period may be created. However, for example, if the single second volume data associated with a last time phase in the analysis period is present, the contrast agent arrival time in the analysis period about each voxel can be grasped.

(In Case of Determining Contrast Agent Temporal Information as Peak Time that Luminance Value Reaches Peak)

[0048] The image generation unit 25 first utilizes the plurality of pieces of first volume data associated with the respective time phases in the analysis period to generate a TIC (Time Intensity Curve) in the analysis period about each voxel. Then, the image generation unit 25 observes a temporal change in luminance of each voxel by using the TIC in the analysis period about each generated voxel and calculates a time T_{peak} , at which a luminance value becomes maximum (a peak) as shown as shown in FIG. 4, in accordance with each voxel. When this calculated time is determined as a voxel value, the second volume data can be generated.

[0049] Even in a situation that the temporal information concerning the contrast agent is the peak time at which the luminance value achieves a peak in this manner, the same number of pieces of second volume data as the plurality of pieces of first volume data associated with the analysis period may be created. However, the arrival time is not updated when it is once obtained. On the other

hand, in case of the peak time, for example, as shown in FIG. 5, a magnitude comparison operation $f(k-1, k)$ (where $k=1, 2, \dots, n$) of luminance values is executed between volumes adjacent to each other in time series, and the temporal information is also updated every time the luminance exceeds a past maximum value. In a strict sense, when observing the luminance until it achieves a peak and Wash-Out is realized, the number of peak time should be one in each voxel. Therefore, for example, if the number of second volume associated with the last time phase in the analysis period is one, an arrival time of the contrast agent in the analysis period can be grasped with respect to each voxel.

(In Case of Determining Contrast Agent Temporal Information is Wash-In time of Contrast Agent)

[0050] As shown in FIG. 4, the Wash-In time is defined as, e.g., a peak time - an arrival time. In such a case, a temporal change in luminance of each voxel can be observed by using the TIC about the analysis time, and a time at which the luminance value exceeds a given threshold value (the arrival time) and a time at which the luminance becomes maximum (the peak) can be specified in accordance with each voxel to calculate the Wash-In time with respect to each voxel. When this calculated time (period) is determined as a voxel value, the second volume data when the temporal information concerning the contrast agent is determined as the Wash-In time of the contrast agent can be generated as, e.g., a single volume.

(In Case of Determining Temporal Information Concerning Contrast Agent as Wash-Out Time)

[0051] As shown in FIG. 4, the Wash-Out time is defined as a period from a time at which a peak is once achieved (the peak time) to a time at which the TIC is reduced to a predetermined threshold value or below. It is to be noted that fitting or smoothing the TIC in advance is preferable. In such a case, a temporal change in luminance in each voxel is observed by using the TIC in the analysis period, and a period from a time at which the luminance value becomes maximum (the peak) to a time at which it becomes the predetermined threshold value or below is calculated in accordance with each voxel. When this calculated time (period) is determined as a voxel value, the second volume data when the temporal information concerning the contrast agent is the Wash-Out time of the contrast agent can be generated as, e.g., a single volume.

[0052] It is to be noted that the generation of the second volume data concerning the various kinds of temporal information about the contrast agent is processing presupposing that the same voxel is placed at the same position. However, in reality, no matter how firmly the probe is held, a hand may be moved, or the probe may be moved due to a patient's breathing, and complexly

fixing the probe is difficult. Thus, for example, correcting a displacement between continuous volumes by an apparatus that adopts a movement correction technology disclosed in JP-A 2007-330764 (KOKAI) is very useful when utilizing this suggested technique in an actual examination.

[Generation of Third Volume Data Representing Contrast Agent Characteristic Amount at Each Position: Step S5]

[0053] Then, the image generation unit 25 utilizes the first volume data for each time phase associated with the analysis period to generate third volume data representing a contrast agent characteristic amount in the analysis period in accordance with each position in the scan target region (a step S5). Here, the contrast agent characteristic amount in the analysis period is, e.g., a maximum value, a minimum value, or an average value of a signal value (a luminance value) at each position in the analysis period.

[0054] For example, it is assumed that a maximum value of a signal value (a luminance value) is used as the contrast agent characteristic amount in the analysis period to trace bubbles for vascular morphology observation. In such a case, the image generation unit 25 generates third volume data by utilizing the first volume data for each time phase associated with the analysis period to carry out temporal maxhold in a time direction with respect to each voxel associated with a spatial position (for example, by sequentially executing a maximum value (magnitude) comparison operation $\text{Max}(k-1, k)$ (where $k=1, 2, \dots, n$) of luminance values between volumes adjacent to each other in time series as shown in FIG. 6 and updating the temporal information every time the luminance exceeds a past maximum value).

[0055] It is to be noted that, when the maximum value of the signal value (the luminance value) is used in this manner, the third volume data may be single data associated with a last time phase in the analysis period. However, when the final single data alone is adopted, a tumor vessel/arterial vessel stained on the earliest stage is embedded in a perfusion stained on the latest stage, the blood vessel may be possibly hard to see. Therefore, it is preferable to create the same number of pieces of third volume data as the plurality of pieces of first volume data associated with the respective time phases in the analysis period.

[Generation of Projected Image using Second and Third Volume Data: Step S6]

[0056] Then, the image generation unit 25 generates a projection image by using the second and the third volume data (Step S6).

[0057] FIG. 7 shows a view for explaining projection processing using the second and the third volume data. FIG. 8 is a view showing an example of a color map used in the projection processing. The color map assigns dif-

ferent color tone to each pixel according to time and pixel values (brightness) of each pixel.

[0058] Then, the image generation unit 25 executes projection processing determining the depth direction as an eye direction as shown in FIG. 7 with respect to the third volume data in accordance with each ray and selects a color tone associated with the contrast agent temporal information in accordance with each position by using the second volume data and a color map shown in FIG. 8, thereby generating a projected image (a four-dimensional parametric image) that the contrast agent characteristic amount at each position in the three-dimensional region is represented as a luminance value and the contrast agent temporal information is represented as a color tone (a step S6).

[0059] Here, in a projection range, a plurality of pieces of temporal information are present in each eye direction (i.e., in accordance with each ray) (in other words, information concerning the depth direction is added). Such assignment of a color phase associated with the temporal information concerning the contrast agent can be represented by any one of the following techniques according to the embodiment.

(Variance Value Display)

[0060] A technique according to this embodiment utilizes variance values to express the plurality of pieces of temporal information present along the eye direction. For example, in a region where blood vessels of a tumor and the like are complicated, the temporal information has a large variance in the depth direction. On the other hand, in a region that mainly consists of capillary blood vessels (perfusions) without large blood vessels, the temporal information has a small variance. That is, for example, whether staining is even or uneven or whether a large quantity of blood vessels and the like are contained can be expressed by changing a color in accordance with a variance.

[0061] FIG. 9 is a graph obtained by plotting a voxel value of the second volume data present on a given ray from a front side toward a far side of an observing point. In this embodiment, as shown in FIG. 9, the image generation unit 25 calculates a variance of the voxel value of the voxel in the second volume data in accordance with each ray and assigns a color tone associated with the obtained variance value.

[0062] It is to be noted that, for example, when another internal organ enters the depth range, the variance value is considered to unnecessarily increase. Therefore, it can be said that setting the projection range is important. Optimization of the projection range can be realized by a later-described technique.

(Average Value Display)

[0063] A technique according to this embodiment expresses the plurality of pieces of temporal information

present along the eye direction by using an average value. That is, the image generation unit 25 calculates an average value of voxel values of voxels in the second volume data in accordance with each ray and assigns luminance associated with the obtained average value.

(Arrival Time Display)

[0064] A technique according to this embodiment expresses the plurality of pieces of temporal information present in the eye direction with an arrival time being determined as a reference. For example, as shown in FIG. 10, the image generation unit 25 searches for a voxel whose arrival time is a minimum value (however, one having the temporal information=0 is excluded), determines a color tone based on this arrival time, and determines a luminance value at a position associated with this voxel by using the first volume data to execute the projection processing.

(Peak Time Display)

[0065] A technique according to this embodiment expresses the plurality of pieces of temporal information present in the eye direction with a peak time (a maximum value) being determined as a reference. For example, as shown in FIG. 11, the image generation unit 25 searches for a voxel having a peak time, determines a color tone based on an arrival time of this voxel, and determines a luminance value at a position associated with this voxel by using the first volume data, thereby executing the projection processing. It is to be noted that, when a plurality of peak times are present, a high priority is put on information of a voxel placed on the front side.

(Others)

[0066] Additionally, besides the respective foregoing embodiments, for example, a voxel having a maximum luminance value (or a voxel having a minimum luminance value) in the depth direction can be specified in the third volume data, and a color tone can be selected by using the temporal information of a voxel in the second volume associated with a position of the former voxel.

[Display of Projected Image: Step S7]

[0067] The generated projected image is combined with predetermined text information and others by the image combination unit 27 and displayed in a predetermined conformation in the monitor 14.

[0068] Modifications of this four-dimensional parametric imaging will now be described.

(Modification 1)

[0069] In this four-dimensional parametric imaging, a thickness of data in the depth direction (a projection

range) as a projection processing target can be adjusted in the projection processing of the step S6. For example, a desired tomographic image is displayed in response to an instruction from a user. The image generation unit 25 determines the displayed tomographic image as a reference and specifies a thickness concerning the depth direction (the projection range). For example, the image generation unit 25 specifies a predetermined range with the tomographic image displayed in the depth direction at the center, a predetermined range extending toward a far side of screen from the displayed tomographic image, or a predetermined range extending toward a front side of the screen from the displayed tomographic image. It is to be noted that this projection range can be arbitrarily adjusted by a manual operation from an operator.

[0070] Based on such a configuration, when the projection range can be set, a user can very easily set an observation range, and the connection between depicted blood vessels can be improved by increasing the thickness. In case of adopting the variance display in the projection processing in particular, for example, when another organ enters the depth range, a variance value unnecessarily increases. Therefore, accurately setting the projection range by using this technique is effective.

(Modification 2)

[0071] In this four-dimensional parametric imaging, a voxel as a projection processing target can be selected (changed/adjusted) in accordance with the contrast agent information in the projection processing of the step S6. For example, when threshold processing is carried out with respect to the second volume data, a voxel that is early or late in terms of the contrast agent temporal information can be selectively displayed. For example, a predetermined threshold value can be provided to the contrast agent temporal information in response to an instruction from the user, and each unnecessary voxel can be excluded by the threshold processing using the provided value, thereby projecting and displaying the second volume data.

(Modification 3)

[0072] In this four-dimensional parametric imaging, a plurality of thicknesses of data in the depth direction (a projection range) as a projection processing target can be set to cover the entire ranges of the first, second, and third volume data in the projection processing of the step S6.

[0073] For example, each piece of first, second, and third volume data is divided into pieces of sub-volume data Vs1 to Vsn having the same width in the depth direction as shown in FIG. 12, each sub-volume data is determined as the projection range, and the projection processing of the step S6 is executed. A division width of the sub-volume can be arbitrarily set by a manual operation from the operator.

[0074] Further, each piece of first, second, and third volume data is divided into pieces of sub-volume data Vs1 to Vsn having respective arbitrary widths in the depth direction as shown in FIG. 13, each sub-volume data is determined as the projection range, and the projection processing of the step S6 is executed. The widths of the respective sub-volumes can be arbitrarily set by a manual operation from the operator.

[0075] Furthermore, each piece of first, second, and third volume data is divided into pieces of sub-volume data Vs1 to Vsn that partially overlap in the depth direction as shown in FIG. 14, each sub-volume data is determined as the projection range, and the projection processing of the step S6 is carried out. It is to be noted that each shaded area in the drawing represents an overlap region of the sub-volumes adjacent to each other. An overlap width can be arbitrarily set by a manual operation from the operator.

[0076] In such cases, projected images, whose number is associated with the respective sub-volumes, are generated. Therefore, at a step S7, each projected image associated with each sub-volume is individually displayed or displayed in a multi-view mode.

[0077] Based on such a configuration, the entire pieces of first, second, and third volume data can be visualized. Therefore, visualization can be carried out based on the four-dimensional parametric imaging without missing a region beneficial to an image diagnosis.

(Effect)

[0078] According to the above-described configuration, in the contrast imaging, the ultrasonic data concerning the three-dimensional region over a predetermined period is utilized to generate the first volume data reflecting a spatial density of the contrast agent (bubbles) in each time phase in the predetermined period. Furthermore, the second volume data representing the contrast agent temporal information at each position in the three-dimensional region and the third volume data representing the contrast agent characteristic amount at each position in the three-dimensional region are generated by using the first volume data for each time phase in the predetermined period. Moreover, the generated second volume data and third volume data are utilized to generate a three-dimensional image that the contrast agent characteristic amount at each position in the three-dimensional region is represented by a luminance value and the contrast agent temporal information is represented by a color tone, and the generated image is displayed in a predetermined conformation. Therefore, the temporal information concerning the depth direction can be appropriately processed, and information such as a dynamic blood flow change or fine angioarchitectonic can be easily observed with high visibility.

[0079] Additionally, in regard to the temporal information, an arrival time, a peak time, a Wash-In time, or a Wash-Out time can be selected as required. Further, as

to the projection technique, a variance value or an arrival time can be selected as reference if need arises. Therefore, a user can set desired parameters in accordance with each situation, thereby realizing the four-dimensional parametric imaging with a high freedom degree. Further, for example, when the projection range is adjusted to prevent other ranges from entering, the preferred embodiment can be realized.

[0080] It is to be noted that the present embodiment is not restricted to the foregoing embodiments as they are, and it can be embodied by modifying constituent elements without departing from the gist of the embodiment on the embodying stage. For example, there are the following specific modifications.

(1) Each function according to this embodiment can be also realized by installing programs executing the processing in a computer such as a workstation and expanding these programs on the memory. At this time, the program that can allow the computer to execute the technique can be stored in a recording medium such as a magnetic disk (a floppy (a registered trademark) disk or a hard disk), an optical disk (a CD-ROM or a DVD), a semiconductor memory, and others so that the program can be distributed in the stored state.

(2) In the foregoing embodiment, the example where the volume data consisting of the voxel data is utilized to execute the four-dimensional parametric imaging processing has been described. However, volume data consisting of raw data may be utilized to execute the four-dimensional parametric imaging processing without being restricted to the above example.

[0081] Further, appropriately combining a plurality of constituent elements disclosed in the foregoing embodiment enables forming various kinds of inventions. For example, some of all the constituent elements disclosed in the embodiment may be deleted. Furthermore, constituent elements in different embodiments may be appropriately combined.

[0082] While certain embodiments have been described, these embodiments have been presented by way of example only, and are not intended to limit the scope of the inventions. Indeed, the novel embodiments described herein may be embodied in a variety of other forms; furthermore, various omissions, substitutions and changes in the form of the embodiments described herein may be made without departing from the scope of the invention. The accompanying claims are intended to cover such forms or modifications as would fall within the scope of the invention.

[0083] It is explicitly stated that all features disclosed in the description and/or the claims are intended to be disclosed separately and independently from each other for the purpose of original disclosure as well as for the purpose of restricting the claimed invention independent

of the composition of the features in the embodiments and/or the claims. It is explicitly stated that all value ranges or indications of groups of entities disclose every possible intermediate value or intermediate entity for the purpose of original disclosure as well as for the purpose of restricting the claimed invention, in particular as limits of value ranges.

Claims

1. An image processing apparatus comprising:

a volume data generation unit (25) configured to generate, based on ultrasonic data acquired by scanning a three-dimensional region in a subject having a contrast agent injected therein over a predetermined period, first volume data, second volume data and third volume data, the ultrasonic data including a harmonic component associated with a signal component from the contrast agent, the first volume data being data of a luminance value representing a spatial density of the contrast agent in each time phase in an analysis period and being generated by extracting the harmonic component from the ultrasonic data concerning the three-dimensional region over the analysis period in the predetermined period, the second volume data being generated from the first volume data and indicating contrast agent temporal information with respect to the luminance value about the analysis period, the contrast agent temporal information being one of an arrival time of the contrast agent at each position in the three-dimensional region, a peak time at which the luminance value becomes a maximum value, a Wash-In time, and a Wash-Out time, and the third volume data being generated from the first volume data and indicating a contrast agent characteristic amount with respect to the luminance value at each position in the three-dimensional region in the analysis period, the contrast agent characteristic amount being one of a maximum value of the luminance value, a minimum value of the luminance value, and an average value of the luminance value; an image generation unit (25) configured to generate a projected image by executing projection processing using the second volume data and the third volume data, and a setting unit (13) configured to set a projection range corresponding to a thickness in a depth direction that is to be a target of the projection processing, wherein the image generation unit assigns, using the set projection range, a color tone asso-

ciated with the contrast agent temporal information and luminance associated with the contrast agent characteristic amount to each position in the three-dimensional region and generates the projected image having the thickness corresponding to the projection range by executing the projection processing to project the assignment result along a projection direction.

2. A medical diagnostic imaging apparatus comprising:

a data acquisition unit (12, 21, 22, 23, 24) configured to image a three-dimensional region in a subject having a contrast agent injected therein over a predetermined period and acquire image data concerning the three-dimensional region over the predetermined period; and an image processing apparatus according to claim 1.

3. An ultrasonic diagnostic apparatus (10) comprising an image processing apparatus according to claim 1, further comprising

a data acquisition unit (12, 21, 22, 23, 24) configured to scan the three-dimensional region in the subject having a contrast agent injected therein over the predetermined period by using ultrasonic waves and to thereby acquire the ultrasonic data concerning the three-dimensional region over the predetermined period.

4. An ultrasonic image processing apparatus comprising an image processing apparatus according to claim 1, further comprising

a memory unit (26) configured to store the ultrasonic data obtained by scanning the three-dimensional region in the subject.

5. The apparatus according to any of claims 2 to 4, wherein the image generation unit (25) is configured to calculate one of a variance value of the contrast agent temporal information, a maximum value of the contrast agent temporal information, a minimum value of the contrast agent temporal information, and an average value of the contrast agent temporal information in regard to each projecting direction by using the second volume data, and the image generation unit (25) is configured to assign a color tone that differs depending on the calculated value.

6. The apparatus according to claim 5, wherein the image generation unit (25) is configured to select a voxel having a maximum or minimum luminance value in regard to each projecting direction by using the third volume data, the image generation unit (25) is configured to specify a voxel in the second volume data associated with

the selected voxel, and
the image generation unit (25) is configured to assign
a color tone that differs depending on the contrast
agent temporal information of the specified voxel.

7. The apparatus according to any of claims 2 to 6,
wherein the volume data generation unit (25) is con-
figured to calculate a temporal change in luminance
value at each position in the three-dimensional re-
gion by using the first volume data in each time phase
in the analysis period, and
the volume data generation unit (25) is configured
to calculate one of the arrival time of the contrast
agent, the peak time, a Wash-In time, and a Wash-
Out time by using the temporal change in the lumi-
nance value at each position in the three-dimension-
al region.
8. The apparatus according to any of claims 1 to 7,
further comprising a display unit configured to per-
form multi-view display of the plurality of projected
images when the plurality of projected images have
been generated.
9. An ultrasonic image processing apparatus compris-
ing an image processing apparatus according to
claim 1, and wherein the image generation unit (25)
selects a representing voxel from the second volume
data and the third volume data in a projection line in
the analysis period and generates the projected im-
age by using a voxel value of the representing voxel
in each projection line.

Patentansprüche

1. Bildverarbeitungsvorrichtung mit:

einer Volumendatenerzeugungseinheit (25), die
dazu ausgebildet ist, basierend auf Ultraschall-
daten, die durch Scannen eines dreidimensio-
nalen Bereichs in einem Probanden, der ein da-
rin eingespritztes Kontrastmittel aufweist, über
einen vorherbestimmten Zeitraum beschafft
werden, erste Volumendaten, zweite Volumen-
daten und dritte Volumendaten zu erzeugen,
welche Ultraschalldaten eine harmonische
Komponente, die mit einer Signalkomponente
von dem Kontrastmittel assoziiert ist, aufweisen,
welche ersten Volumendaten Daten eines Lumi-
nanzwerts, der eine räumliche Dichte des
Kontrastmittels darstellt, in jeder Zeitphase in ei-
nem Untersuchungszeitraum sind und durch
Extrahieren der harmonischen Komponente
aus den Ultraschalldaten betreffend den dreidi-
mensionalen Bereich über den Untersuchungs-
zeitraum in dem vorherbestimmten Zeitraum er-
zeugt werden,

welche zweiten Volumendaten aus den ersten
Volumendaten erzeugt werden und Kontrast-
mittelzeitinformation in Bezug auf den Lumi-
nanzwert über den Untersuchungszeitraum an-
geben, welche Kontrastmittelzeitinformation ei-
ne von einer Ankunftszeit des Kontrastmittels
an jeder Position in dem dreidimensionalen Be-
reich, einer Spitzenzeit, bei der der Luminanz-
wert ein Maximalwert wird, einer Einwaschzeit
und einer Auswaschzeit ist, und
welche dritten Volumendaten aus den ersten
Volumendaten erzeugt werden und ein Kon-
trastmittelcharakteristikmaß in Bezug auf den
Luminanzwert an jeder Position in dem dreidi-
mensionalen Bereich in dem Untersuchungs-
zeitraum angeben, welches Kontrastmittelcha-
rakteristikmaß einer von einem Maximalwert
des Luminanzwerts, einem Minimalwert des Lu-
minanzwerts und einem Durchschnittswert des
Luminanzwerts ist;
einer Bilderzeugungseinheit (25), die dazu aus-
gebildet ist, ein projiziertes Bild durch Ausfüh-
ren von Projektionsverarbeitung unter Verwendung
der zweiten Volumendaten und der dritten Vo-
lumendaten zu erzeugen, und
einer Festlegungseinheit (13), die dazu ausge-
bildet ist, einen Projektionsbereich, der einer Di-
cke in einer Tiefenrichtung, die ein Ziel der Pro-
jektionsverarbeitung zu sein hat, entspricht,
festzulegen,
bei der die Bilderzeugungseinheit, unter Ver-
wendung des festgelegten Projektionsbereichs,
einen Farbton, der mit der Kontrastmittelzeitin-
formation assoziiert ist, und Luminanz, die mit
dem Kontrastmittelcharakteristikmaß assoziiert
ist, jeder Position in dem dreidimensionalen Be-
reich zuordnet und das projizierte Bild, das die
Dicke aufweist, die dem Projektionsbereich ent-
spricht, durch Ausführen der Projektionsverar-
beitung zum Projizieren des Zuordnungsergeb-
nisses entlang einer Projektionsrichtung er-
zeugt.

2. Medizinische Diagnoseabbildungsvorrichtung mit:

einer Datenbeschaffungseinheit (12, 21, 22, 23,
24), die dazu ausgebildet ist, einen dreidimen-
sionalen Bereich in einem Probanden, der ein
darin injiziertes Kontrastmittel aufweist, über ei-
nen vorherbestimmten Zeitraum abzubilden
und Bilddaten betreffend den dreidimensio-
nalen Bereich über den vorherbestimmten Zeit-
raum zu beschaffen; und
einer Bildverarbeitungsvorrichtung nach An-
spruch 1.

3. Ultraschalldiagnosevorrichtung (10) mit einer Bild-
verarbeitungsvorrichtung nach Anspruch 1, ferner

- mit einer Datenbeschaffungseinheit (12, 21, 22, 23, 24), die dazu ausgebildet ist, den dreidimensionalen Bereich in dem Probanden, der das darin injizierte Kontrastmittel aufweist, über den vorherbestimmten Zeitraum unter Verwendung von Ultraschallwellen zu scannen und dadurch die Ultraschalldaten betreffend den dreidimensionalen Bereich über den vorherbestimmten Zeitraum zu beschaffen.
4. Ultraschallbildverarbeitungsvorrichtung mit einer Bildverarbeitungsvorrichtung nach Anspruch 1, ferner mit einer Speichereinheit (26), die dazu ausgebildet ist, die Ultraschalldaten, die durch Scannen des dreidimensionalen Bereichs in dem Probanden erhalten werden, zu speichern,
5. Vorrichtung nach einem der Ansprüche 2 bis 4, bei der die Bilderzeugungseinheit (25) dazu ausgebildet ist, einen von einem Varianzwert der Kontrastmittelzeitinformation, einem Maximalwert der Kontrastmittelzeitinformation, einem Minimalwert der Kontrastmittelzeitinformation und einem Durchschnittswert der Kontrastmittelzeitinformation hinsichtlich jeder Projektionsrichtung unter Verwendung der zweiten Volumendaten zu berechnen, und die Bilderzeugungseinheit (25) dazu ausgebildet ist, einen Farbton, der abhängig von dem berechneten Wert verschieden ist, zuzuordnen.
6. Vorrichtung nach Anspruch 5, bei der die Bilderzeugungseinheit (25) dazu ausgebildet ist, ein Voxel, das einen maximalen oder minimalen Luminanzwert aufweist, hinsichtlich jeder Projektionsrichtung unter Verwendung der dritten Volumendaten auszuwählen, die Bilderzeugungseinheit (25) dazu ausgebildet ist, ein Voxel in den zweiten Volumendaten, das mit dem ausgewählten Voxel assoziiert ist, zu spezifizieren, und die Bilderzeugungseinheit (25) dazu ausgebildet ist, einen Farbton, der abhängig von der Kontrastmittelzeitinformation des spezifizierten Voxels verschieden ist, zuzuordnen.
7. Vorrichtung nach einem der Ansprüche 2 bis 6, bei der die Volumendatenerzeugungseinheit (25) dazu ausgebildet ist, eine zeitliche Änderung im Luminanzwert an jeder Position in dem dreidimensionalen Bereich unter Verwendung der ersten Volumendaten in jeder Zeitphase in dem Untersuchungszeitraum zu berechnen, und die Volumendatenerzeugungseinheit (25) dazu ausgebildet ist, eine von der Ankunftszeit des Kontrastmittels, der Spitzenzeit, einer Einwaschzeit und einer Auswaschzeit unter Verwendung der zeitlichen Änderung in dem Luminanzwert an jeder Position in

dem dreidimensionalen Bereich zu berechnen.

8. Vorrichtung nach einem der Ansprüche 1 bis 7, ferner mit einer Anzeigeeinheit, die dazu ausgebildet ist, eine Mehrfachansichtsanzeige der Mehrzahl projizierter Bilder durchzuführen, wenn die Mehrzahl projizierter Bilder erzeugt worden ist.
9. Ultraschallbildverarbeitungsvorrichtung mit einer Bildverarbeitungsvorrichtung nach Anspruch 1, und bei der die Bilderzeugungseinheit (25) ein repräsentierendes Voxel aus den zweiten Volumendaten und den dritten Volumendaten in einer Projektionslinie in dem Untersuchungszeitraum auswählt und das projizierte Bild unter Verwendung eines Voxelwerts des repräsentierenden Voxels in jeder Projektionslinie erzeugt.

20 Revendications

1. Appareil de traitement d'images comprenant :

une unité de génération de données de volume (25) configurée pour générer, sur la base de données ultrasonores acquises en balayant une région tridimensionnelle dans un sujet ayant un agent de contraste injecté sur une période prédéterminée, des premières données de volume, des deuxièmes données de volume et des troisièmes données de volume, les données ultrasonores comprenant une composante harmonique associée à une composante de signal provenant de l'agent de contraste, les données de premier volume étant des données d'une valeur de luminance représentant une densité spatiale de l'agent de contraste dans chaque phase temporelle d'une période d'analyse et étant générées par extraction de la composante harmonique des données ultrasonores concernant la région tridimensionnelle sur la période d'analyse dans la période prédéterminée, les données de deuxième volume étant générées à partir des données de premier volume et indiquant une information temporelle d'agent de contraste par rapport à la valeur de luminance sur la période d'analyse, l'information temporelle d'agent de contraste étant un temps parmi un temps d'arrivée de l'agent de contraste à chaque position dans la région tridimensionnelle, un temps de pic auquel la valeur de luminance devient une valeur maximale, un temps de Wash-In et un temps de Wash-Out, et les données de troisième volume étant générées à partir des données de premier volume et indiquant une quantité caractéristique d'agent de contraste par rapport à la valeur de luminan-

- ce à chaque position dans la région tridimensionnelle dans la période d'analyse, la quantité caractéristique d'agent de contraste étant une valeur parmi une valeur maximale de la valeur de luminance, une valeur minimale de la valeur de luminance et une valeur moyenne de la valeur de luminance ;
- une unité de génération d'images (25) configurée pour générer une image projetée en exécutant un traitement de projection utilisant les données de deuxième volume et les données de troisième volume, et
- une unité de réglage (13) configurée pour définir une plage de projection correspondant à une épaisseur dans une direction de profondeur qui doit être une cible du traitement de projection, dans lequel l'unité de génération d'images attribue, en utilisant la plage de projection définie, une tonalité de couleur associée à l'information temporelle d'agent de contraste et la luminance associée à la quantité caractéristique d'agent de contraste à chaque position dans la région tridimensionnelle et génère l'image projetée ayant l'épaisseur correspondant à la plage de projection en exécutant le traitement de projection pour projeter le résultat d'attribution le long d'une direction de projection.
2. Appareil d'imagerie pour le diagnostic médical comprenant :
- une unité d'acquisition de données (12, 21, 22, 23, 24) configurée pour représenter une région tridimensionnelle dans un sujet ayant un agent de contraste qui y est injecté sur une période prédéterminée et pour acquérir des données d'images concernant la région tridimensionnelle sur la période prédéterminée ; et
- un appareil de traitement d'images selon la revendication 1.
3. Appareil de diagnostic à ultrasons (10) comprenant un appareil de traitement d'images selon la revendication 1, comprenant en outre
- une unité d'acquisition de données (12, 21, 22, 23, 24) configurée pour balayer la région tridimensionnelle dans le sujet ayant un agent de contraste qui y est injecté pendant la période prédéterminée en utilisant des ondes ultrasonores et pour acquérir ainsi les données ultrasonores concernant la région tridimensionnelle pendant la période prédéterminée.
4. Appareil de traitement d'images à ultrasons comprenant un appareil de traitement d'images selon la revendication 1, comprenant en outre
- une unité de mémoire (26) configurée pour stocker les données ultrasonores obtenues par balayage de la région tridimensionnelle du sujet.
5. Appareil selon l'une quelconque des revendications 2 à 4, dans lequel l'unité de génération d'images (25) est configurée pour calculer une valeur parmi une valeur de variance de l'information temporelle d'agent de contraste, une valeur maximale de l'information temporelle d'agent de contraste, d'une valeur minimale de l'information temporelle d'agent de contraste, et une valeur moyenne de l'information temporelle d'agent de contraste en ce qui concerne chaque direction de projection en utilisant les données de deuxième volume, et l'unité de génération d'images (25) est configurée pour attribuer une tonalité de couleur qui diffère selon la valeur calculée.
6. Appareil selon la revendication 5, dans lequel l'unité de génération d'images (25) est configurée pour sélectionner un voxel ayant une valeur de luminance maximale ou minimale en ce qui concerne chaque direction de projection en utilisant les données de troisième volume, l'unité de génération d'images (25) est configurée pour spécifier un voxel dans le deuxième données de volume associé au voxel sélectionné, et l'unité de génération d'images (25) est configurée pour attribuer une tonalité de couleur qui diffère selon l'information temporelle d'agent de contraste du voxel spécifié.
7. Appareil selon l'une quelconque des revendications 2 à 6, dans lequel l'unité de génération de données de volume (25) est configurée pour calculer un changement temporel dans une valeur de luminance à chaque position dans la région tridimensionnelle en utilisant les premières données de volume dans chaque phase temporelle de la période d'analyse, et l'unité de génération de données de volume (25) est configurée pour calculer un temps parmi le temps d'arrivée de l'agent de contraste, le temps de pic, un temps de Wash-In et un temps de Wash-Out en utilisant le changement temporel de la valeur de luminance à chaque position dans la région tridimensionnelle.
8. Appareil selon l'une quelconque des revendications 1 à 7, comprenant en outre une unité d'affichage configurée pour effectuer un affichage multi-vues de la pluralité d'images projetées lorsque la pluralité d'images projetées a été générée.
9. Appareil de traitement d'images à ultrasons comprenant un appareil de traitement d'images selon la revendication 1, et dans lequel l'unité de génération d'images (25) sélectionne un voxel représentatif à partir des données de deuxième volume et des données de troisième volume dans une ligne de projection dans la période d'analyse et génère l'image projetée en utilisant une valeur de voxel du voxel repré-

sentatif dans chaque ligne de projection.

5

10

15

20

25

30

35

40

45

50

55

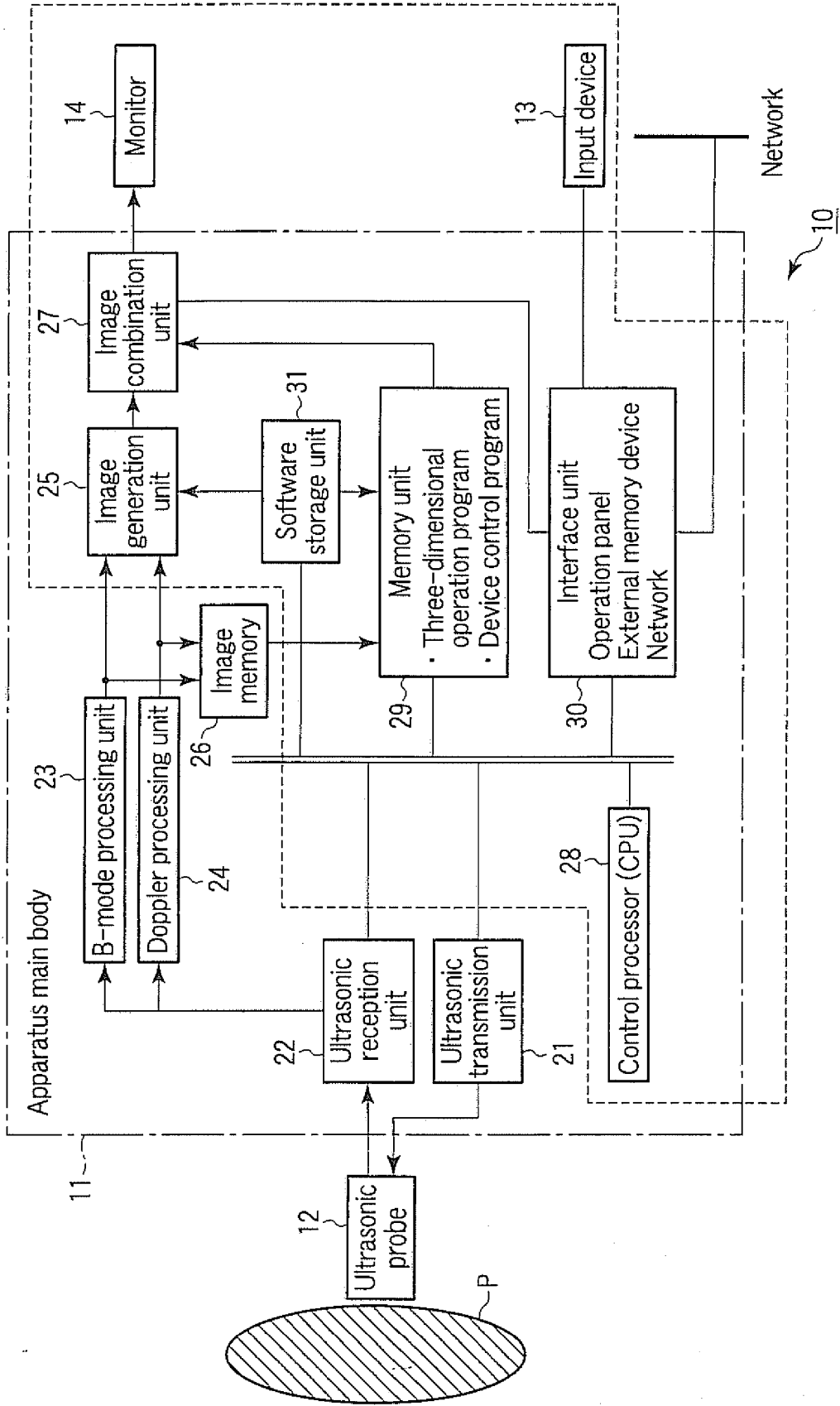

FIG. 1

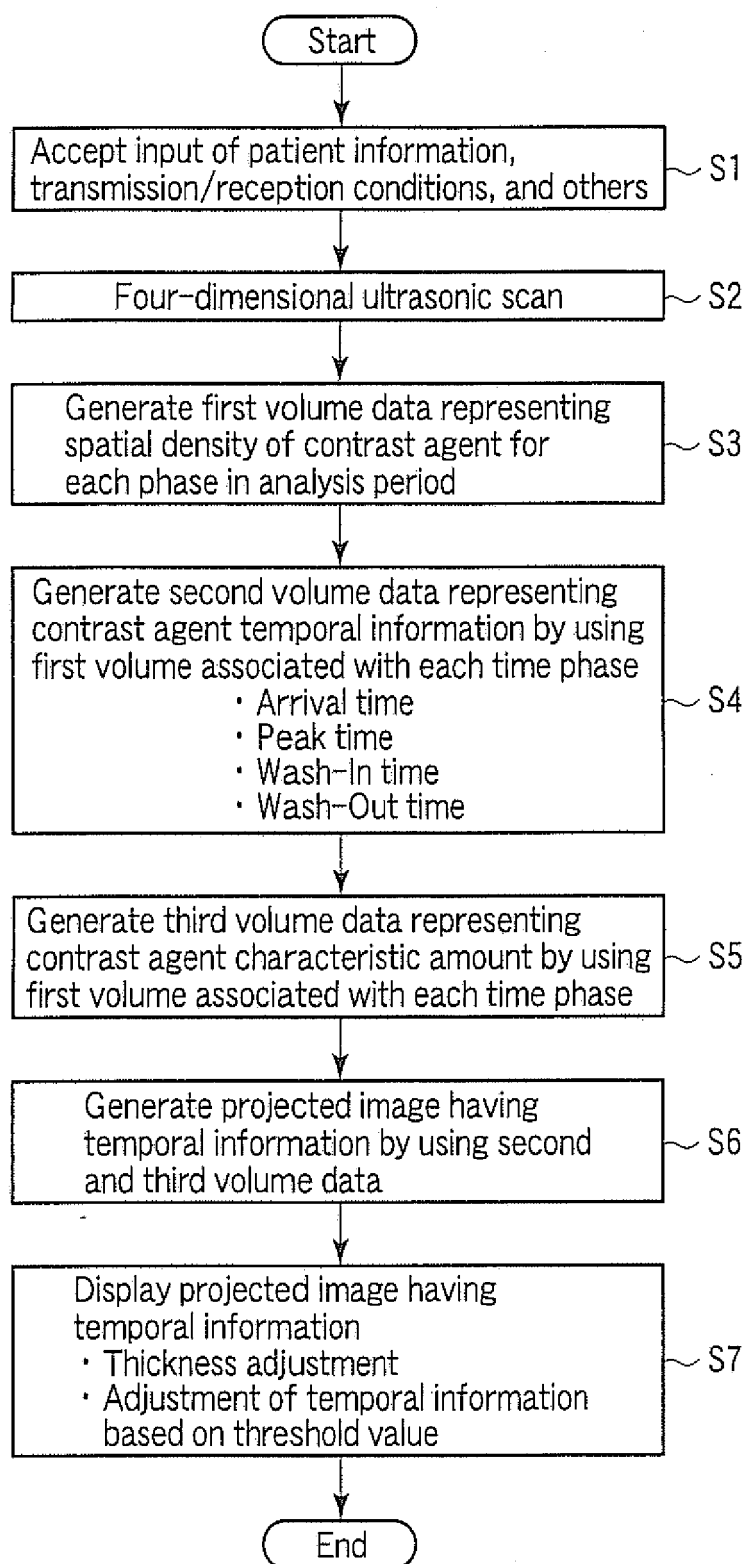

FIG. 2

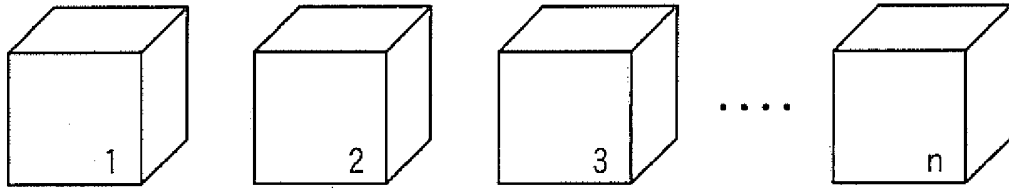

FIG. 3

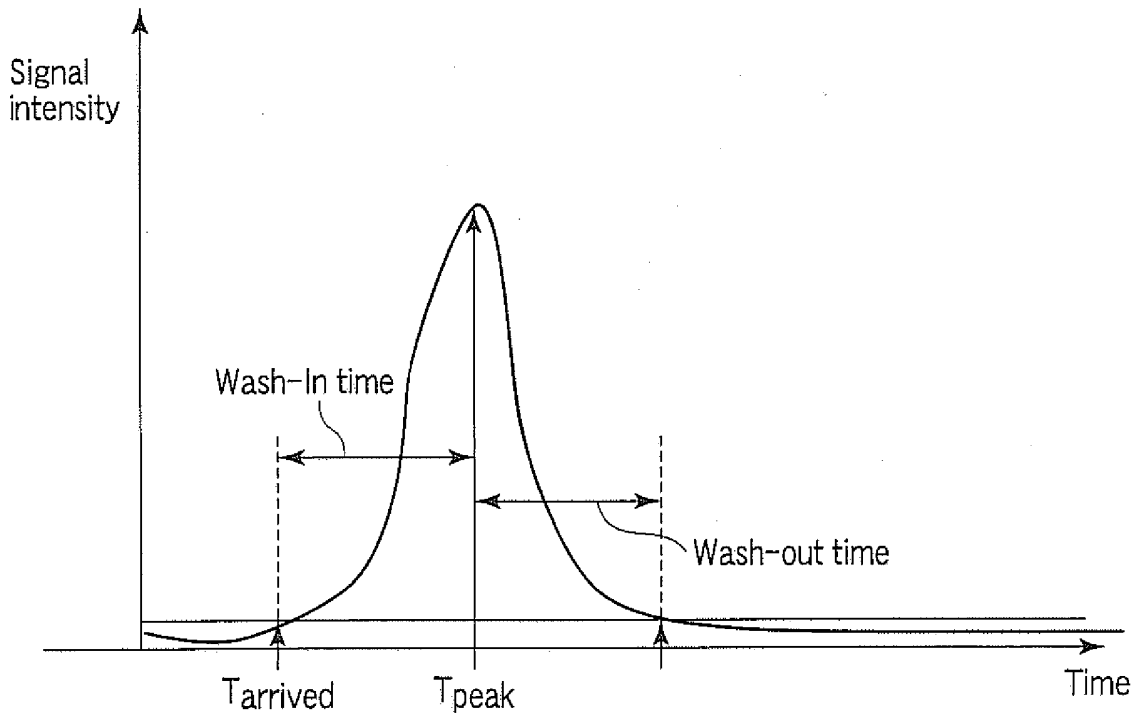

FIG. 4

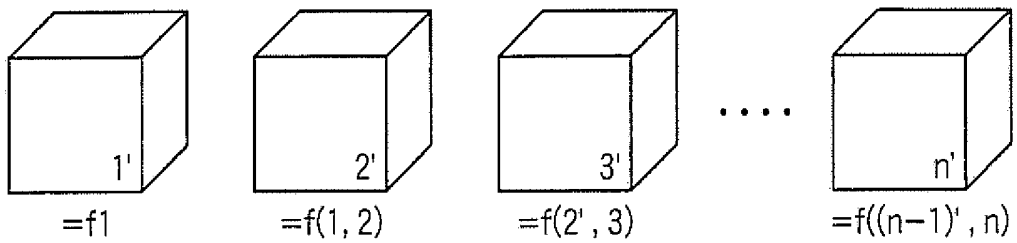

FIG. 5

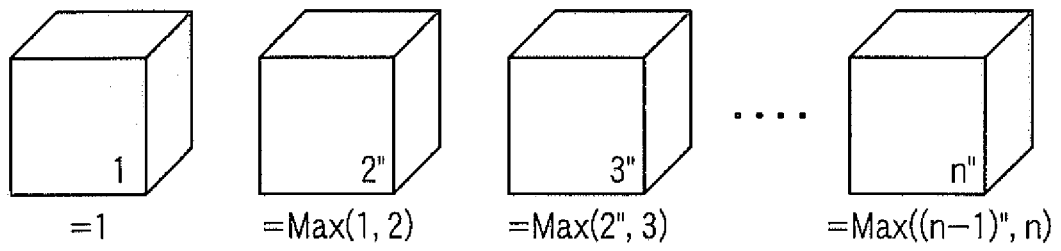

FIG. 6

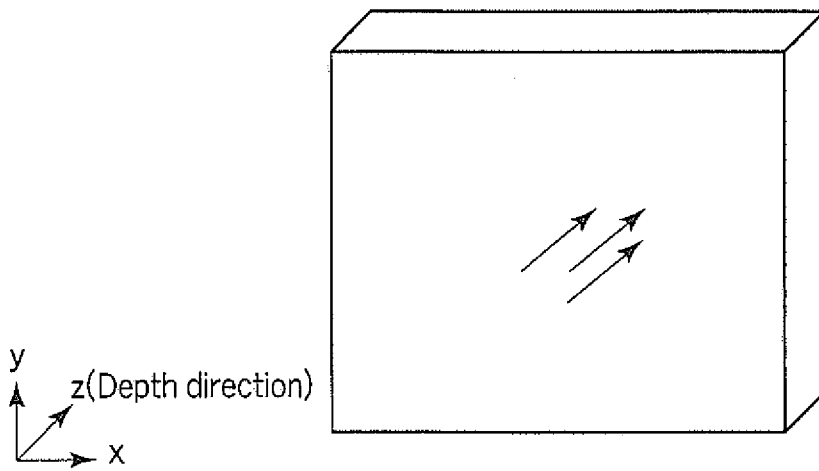

FIG. 7

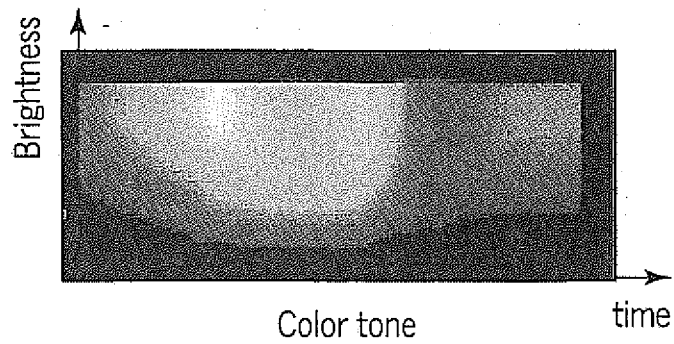

FIG. 8

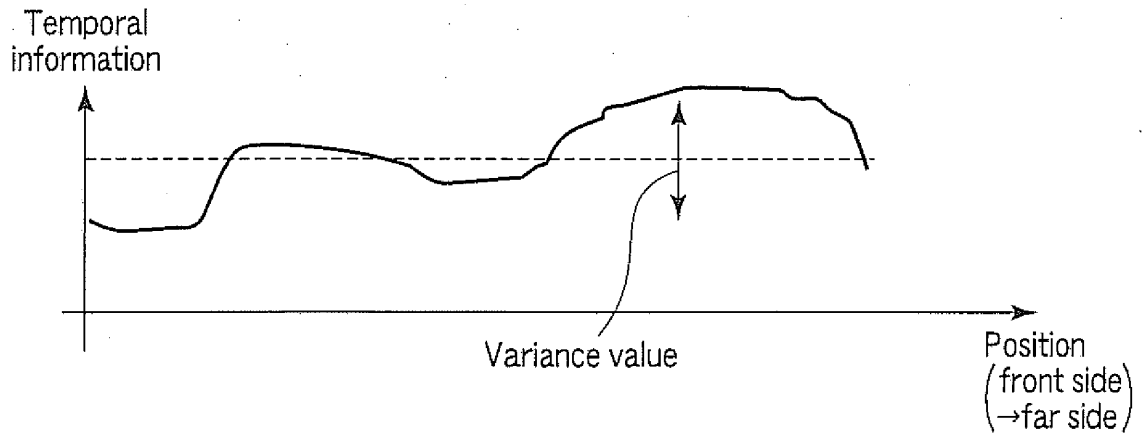

FIG. 9

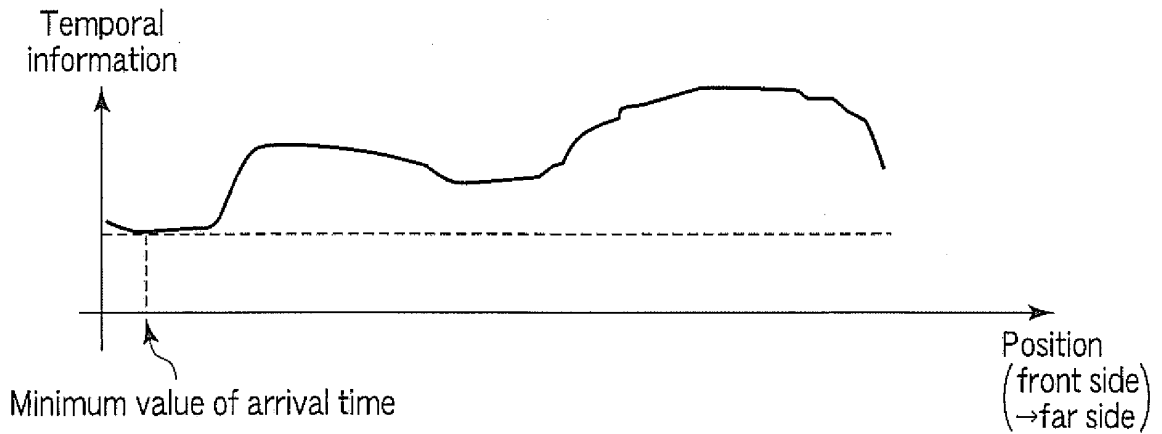

FIG. 10

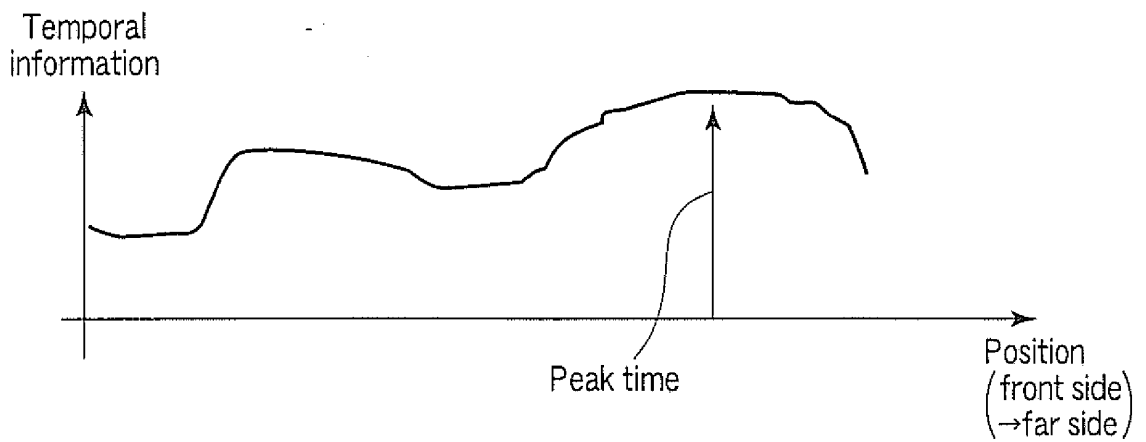
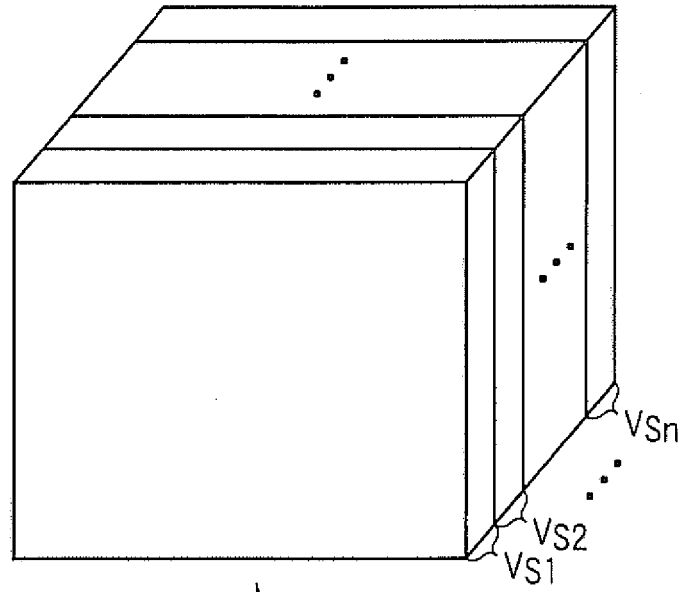
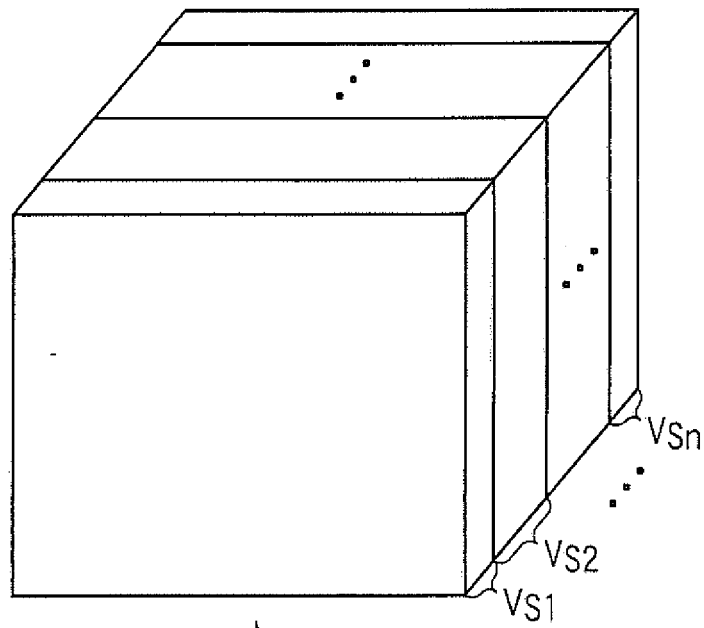

FIG. 11



First, second, or third volume data

FIG. 12



First, second, or third volume data

FIG. 13

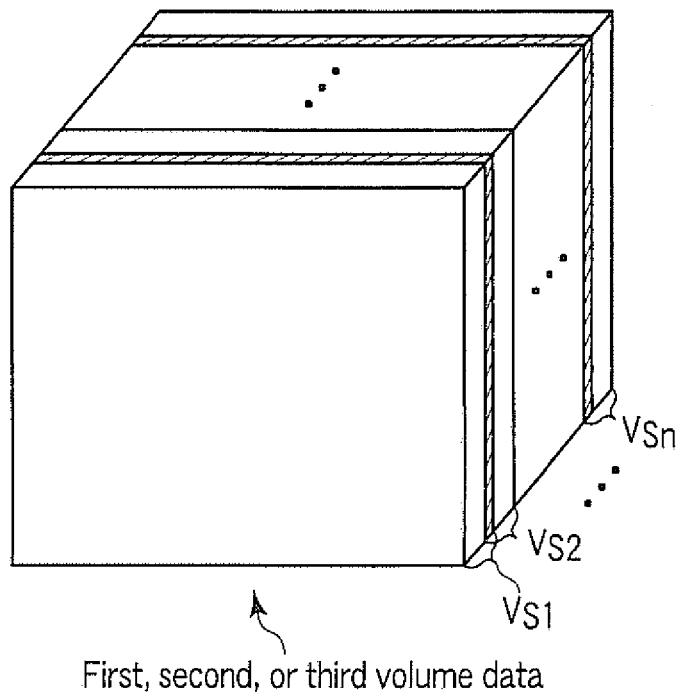

FIG. 14

REFERENCES CITED IN THE DESCRIPTION

This list of references cited by the applicant is for the reader's convenience only. It does not form part of the European patent document. Even though great care has been taken in compiling the references, errors or omissions cannot be excluded and the EPO disclaims all liability in this regard.

Patent documents cited in the description

- WO 2005054898 A [0005]
- JP 2007330764 A [0052]

专利名称(译)	超声诊断设备,超声图像处理设备和用于医学诊断的成像设备		
公开(公告)号	EP2371290B1	公开(公告)日	2020-07-01
申请号	EP2011160314	申请日	2011-03-29
[标]申请(专利权)人(译)	株式会社东芝 东芝医疗系统株式会社		
申请(专利权)人(译)	株式会社东芝 东芝医疗系统公司		
当前申请(专利权)人(译)	东芝医疗系统公司		
[标]发明人	YOSHIDA TETSUYA KUGA ITSUKI		
发明人	YOSHIDA, TETSUYA KUGA, ITSUKI		
IPC分类号	A61B8/00		
CPC分类号	A61B8/461 A61B8/463 A61B8/466 A61B8/481 A61B8/483 G01S7/52071 G01S15/8979 G01S15/8993		
优先权	2010078909 2010-03-30 JP		
其他公开文献	EP2371290A1		
外部链接	Espacenet		

摘要(译)

根据一个实施例,提供了一种超声诊断设备(10),其包括数据获取单元(12、21、22、23、24),该数据获取单元被配置为扫描在其中注入有造影剂的对象中的三维区域。通过使用超声波在预定时间段内并由此获取在预定时间段内与三维区域有关的超声数据,体数据生成单元(25)被配置为通过使用超声数据在分析周期中的每个时间阶段生成第一体数据 在预定时段内在分析时段上涉及三维区域,并生成指示关于分析时段的造影剂时间信息的第二体数据和表示三维区域中每个位置处的造影剂特征量的第三体数据 在分析周期中,图像生成单元(25)被配置为通过使用第二体积数据来生成投影图像 a和第三卷数据。

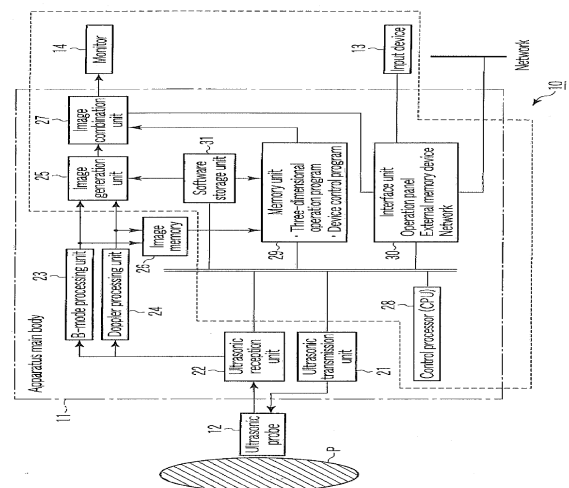

FIG. 1