



(11) **EP 2 134 262 B1**

(12) **EUROPEAN PATENT SPECIFICATION**

(45) Date of publication and mention of the grant of the patent:
12.06.2019 Bulletin 2019/24

(21) Application number: **08745338.7**

(22) Date of filing: **09.04.2008**

(51) Int Cl.:
A61B 8/06 (2006.01) **A61B 8/14 (2006.01)**
A61B 8/08 (2006.01) **A61B 8/00 (2006.01)**
G01S 15/89 (2006.01) **G01S 7/52 (2006.01)**

(86) International application number:
PCT/US2008/059705

(87) International publication number:
WO 2008/127928 (23.10.2008 Gazette 2008/43)

(54) **QUANTIFIED PERFUSION STUDIES WITH ULTRASONIC THICK SLICE IMAGING**

QUANTIFIZIERTE PERFUSIONSSTUDIEN MIT THICK-SLICE-ULTRASCHALLBILDGEBUNG

ETUDE DE PERFUSION QUANTIFIÉE AVEC IMAGERIE EN COUPE ÉPAISSE ULTRASONIQUE

(84) Designated Contracting States:
AT BE BG CH CY CZ DE DK EE ES FI FR GB GR HR HU IE IS IT LI LT LU LV MC MT NL NO PL PT RO SE SI SK TR

(30) Priority: **13.04.2007 US 911598 P**

(43) Date of publication of application:
23.12.2009 Bulletin 2009/52

(73) Proprietor: **Koninklijke Philips N.V.**
5656 AE Eindhoven (NL)

(72) Inventors:
• **RAFTER, Patrick, G.**
Bothell, Washington 98041-3003 (US)
• **THIELE, Karl**
Bothell, Washington 98041-3003 (US)

• **BURNHAM, Robert, L.**
Bothell, Washington 98041-3003 (US)

(74) Representative: **van Velzen, Maaïke Mathilde**
Philips Intellectual Property & Standards
High Tech Campus 5
5656 AE Eindhoven (NL)

(56) References cited:
WO-A1-2005/072617 **WO-A2-01/69282**
US-A- 5 318 033 **US-A- 6 015 384**
US-A1- 2005 075 567 **US-A1- 2006 067 567**
US-B1- 6 464 638 **US-B1- 6 645 147**
US-B1- 6 749 569 **US-B2- 6 692 438**
US-B2- 7 097 619

EP 2 134 262 B1

Note: Within nine months of the publication of the mention of the grant of the European patent in the European Patent Bulletin, any person may give notice to the European Patent Office of opposition to that patent, in accordance with the Implementing Regulations. Notice of opposition shall not be deemed to have been filed until the opposition fee has been paid. (Art. 99(1) European Patent Convention).

Description

[0001] This invention relates to medical diagnostic ultrasound systems and, in particular, to ultrasound systems which enable the performance of perfusion display and quantification with ultrasonic thick slice images.

[0002] It has long been the desire of echo-cardiographers to be able to use ultrasound for the quantification of myocardial perfusion. Infarcted myocardial tissue which is completely lacking in blood flow is sometimes easy to diagnose by reason of both its blood flow and motional characteristics. However, it is much more difficult to detect and diagnose partially infarcted or ischemic regions of the myocardium which may be suffering perfusion deficit. This task has been aided considerably in recent years by the advent of ultrasonic microbubble contrast agents. Not only does the contrast agent better highlight the perfusion of the myocardium, but it also enables "flash-replenishment," by which the microbubbles are disrupted by high ultrasonic energy, then the replenishment of microbubbles by the blood flow is observed and measured. A quantified measure of this replenishment is the time-intensity curve of replenishment which measures the rate of blood flow in localized regions of interest. By this technique the perfusion of the myocardium can be displayed qualitatively with color depicting the flow characteristic, and quantified parameters derived which measure the rate of reperfusion of a region of the heart.

[0003] One of the difficulties that has always been present in ultrasound is the mottling of images by the speckle artifact. Ultrasonic imaging is an imaging modality which forms images of coherent signal information. The nature of the coherent ultrasonic signals used, like the monochromatic lightwaves used for holographic imaging, results in constructive and destructive interference of the waves in the medium being imaged. As a result, the image contains noise in the form of a random mottling of the image known as "speckle." When a region of interest is monitored for the replenishment of blood as indicated by the replenishment of the contrast agent carried by the blood flow, relatively low transmit power is used so that the microbubbles of the agent can be observed without disruption. As a result, contrast images exhibit lower signal-to-noise ratios than do standard images. In addition the contrast images will exhibit a lower display dynamic range than standard images, causing them to have reduced contrast resolution. These factors combine to make the speckle artifact more pronounced and more severe for contrast images.

[0004] Since the speckle pattern of an image is constant and does not vary with time, the common approach to reducing the effect is to combine uncorrelated image data and reduce the speckle by an averaging effect proportional to the square root of two. The types of uncorrelated data used are typically data that are of different frequencies or acquired from different look directions, commonly known as frequency compounding (see, e.g., US Pat. 4,350,917 to Lizzi et al.) and spatial compound-

ing (see, e.g., US Pat. 4,649,927 to Fehr et al.) Frequency compounding, however, leads to a reduction in contrast-to-tissue ratio and signal-to-noise. This is because the different frequency bands that are compounded will have different signal-to-noise and different contrast-to-tissue ratios, which are generally equalized by adjusting the gain in one or more of the bands. The increase in gain will also increase the noise in the affected band, thereby decreasing the signal-to-noise ratio of the frequency compounded image.

[0005] WO 2005/072617 A1 discloses a method and a device for conducting perfusion studies on myocardial tissues with contrast agents. Ultrasound pulses are transmitted into a patient, and ultrasound echoes of the pulses are received which correspond to both myocardial tissue blood and chamber blood within said patient. The received ultrasound echoes are converted into image data which corresponds to essentially only the myocardium perfusion.

[0006] US 2005/0075567 A1 discloses a method and system for tracing a tissue border in a medical diagnostic image in which a diagnostic image containing the tissue to be traced is acquired. A user manipulates a cursor on the image display to designate three landmarks on the boundary of the tissue. An automated border detector then fits a stored boundary shape to the three landmarks. The fitted border can thereafter be adjusted to precisely fit the boundary by a rubberbanding process.

[0007] US Pat. 6,464,638 to Adams et al. describes a new approach to spatial compounding which makes good utilization of probes designed for three dimensional imaging. In the Adams et al. technique a 3D imaging probe acquires images of planes which are substantially parallel to each other in the elevational dimension, the dimension normal to the image plane. In a typical implementation, Adams et al. use a probe with electronic beam steering and focusing in both azimuth and elevation to acquire not only an image of the slice plane of interest but also image planes offset from that slice plane. The slices are then combined elevationally and the at least minimally uncorrelated data in the elevational dimension effects speckle reduction by spatial compounding in the elevational dimension. It would be desirable to apply this approach to reduce the speckle of an ultrasound contrast image while having a minimal effect on spatial resolution and signal-to-noise, thereby enabling more robust quantification and parametric imaging with ultrasound contrast agents.

[0008] In accordance with the principles of the present invention, a diagnostic ultrasound system according claim 1 is provided. The diagnostic ultrasound system allows to scan a plurality of slices of tissue which may have perfusion defects with a 3D imaging probe. The acquired image slices are substantially parallel in the elevational dimension. Following the acquisition of multiple slices, the image data of the slices is projected and combined in the elevation dimension to form a "thick slice" image. The thick slice image is then subjected to per-

fusion detection to highlight areas of perfused and unperfused tissue in the image in accordance with their concentrations of microbubbles, or to quantify the rate of perfusion as by the measurement of wash in, wash out curves and curve parameters at localized regions of the tissue.

[0009] In the drawings:

FIGURE 1 illustrates a plurality of sector slices acquired in the elevational direction.

FIGURE 2 illustrates a plurality of rectilinear slices acquired in the elevational direction.

FIGURE 3 illustrates a plurality of slices which are at different angular increments in the elevational direction.

FIGURES 4a-4c illustrate the acquisition of multiple slices simultaneously by multiline acquisition in accordance with the principles of the present invention. FIGURE 5 illustrates in block diagram form an ultrasonic diagnostic imaging system constructed in accordance with the principles of the present invention. FIGURE 6 illustrates in block diagram form a second implementation of an ultrasonic diagnostic imaging system constructed in accordance with the principles of the present invention.

FIGURE 7a illustrates a dual ported memory used for slice storage in an implementation of the present invention.

FIGURE 7b illustrates partitioning of memory areas in an implementation of the present invention.

FIGURE 8 illustrates an ultrasound system display screen showing qualitative and quantitative indications blood flow perfusion of the myocardium.

[0010] Referring first to FIGURE 1, a volumetric region 10 is shown in perspective. In this example the volumetric region 10 is sector-shaped and contains a plurality of planar sector-shaped areas which are referred to herein as "slices." Four slices 12-18 are illustrated in this example. The slices are oriented parallel to each other in the elevation direction with their azimuth and elevation dimensions indicated to the right of the drawing. Each slice may be scanned by an array transducer located above the volumetric region by transmitting successive scanlines across a slice 12-18 in the azimuth direction and progressing from slice to slice in the elevation direction.

[0011] FIGURE 2 illustrates a rectilinear volumetric region 20 which also includes a plurality of slices oriented in parallel in the elevation direction. Four such slices 22-28 are shown in the drawing. These slices may be scanned in the same manner as the slices of FIGURE 1 by a transducer array located above the volumetric region 20. In this example the slices are scanned by parallel scanlines in the azimuth direction rather than by angularly incremented scanlines from a common origin as is the case in the example of FIGURE 1.

[0012] FIGURE 3 provides another example of slices of a volumetric region. These slices are of a pyramidal

volumetric region with an apex 34 at the top of the volume. In this example four sector-shaped slices S_1 - S_4 are shown in an "edge-on" view. That is, the elevation direction of the slices is indicated by the arrow 32, and the azimuth direction is into the plane of the drawing. The azimuth and elevation directions with respect to the array transducer 30 are shown above the transducer array. In this example neighboring elevation slices are substantially parallel and are separated from each other by an angular increment $\Delta\phi$.

[0013] In each of these examples a single slice of a volume may be scanned and displayed. But in accordance with the principles of the present invention, a plurality of slices which are elevationally aligned are scanned and their data combined to form an image for display. Since each of the elevationally distinct slices is scanned by scanlines having different transmit-receive signal paths, each of the slices will exhibit its own unique speckle pattern. By combining the image data of a plurality of slices which define a thickness in the elevation dimension, the speckle artifact of the combined image will be reduced.

[0014] In accordance with the present invention, the slices are scanned at a high speed by multiline acquisition. In multiline acquisition, one transmit beam insonifies multiple receive line locations and multiple receive lines are acquired in response to the single transmit event. FIGURES 4a-4c provide an example of multiline acquisition of four slices S_1 - S_4 which are arranged in parallel in the elevational dimension. Each slice is made up of receive lines arrayed in the azimuth direction and identified in the drawing as L_1, L_2, \dots, L_n , where "n" may be 128, for instance. In the view of FIGURE 4, each receive line is being viewed axially as it would from the perspective of the transducer array. Rather than transmit a single transmit beam down each line and receive echoes from only that receive line, four receive lines are insonified by a single transmit beam. In the example of FIGURE 4a a transmit beam TxA_1 , outlined radially, insonifies receive lines L_1 and L_2 of slice S_1 and receive lines L_1 and L_2 of slice S_2 . Thus, two receive lines in azimuth and two receive lines in elevation, a total of four receive lines, are acquired simultaneously and processed. See, e.g., US Pat. 5,318,033 (Savord) for an explanation of the processing of simultaneously received multilines. FIGURE 4b illustrates the next transmit event, in which a transmit beam TxA_2 insonifies another four receive lines, L_3 and L_4 of slice S_1 and receive lines L_3 and L_4 of slice S_2 . Scanning proceeds in this manner until all of the lines of slices S_1 and S_2 have been acquired. Thus in the interval during which the full azimuth of a slice has been scanned, from line L_1 through line L_n , echo data from two slices, S_1 and S_2 , has been acquired. The process then continues with a second azimuth scanning interval as shown in FIGURE 4c with the scanning of receive lines L_1 and L_2 of slice S_3 together with receive lines L_1 and L_2 of slice S_4 by transmit beam TxB_1 . Slices S_3 and S_4 are scanned during this second azimuth scanning in-

terval in the same manner as slices S_1 and S_2 were acquired during the first. In these two scanning intervals all four slices S_1 - S_4 are scanned in the time required to scan a single slice in the conventional line-by-line approach. The speed of acquisition and hence the frame rate of display have been increased by a factor of four by the use of this 4X multiline acquisition.

[0015] An ultrasound system constructed in accordance with the principles of the present invention is shown in block diagram form in FIGURE 5. A two dimensional array transducer 30 is provided which electronically steers and focuses beams over a volumetric region 10 under control of a microbeamformer 36, main beamformer 38, and beamformer controller 42. Alternatively, a one dimensional array transducer can be mechanically oscillated to scan the volumetric region. In this case the microbeamformer 36 located in the probe case with the 2D transducer array 30 controls the scanning of groups of elements called subarrays or patches in scanning a volumetric region 10. Partially beamformed signals from the microbeamformer 36 are formed into fully beamformed signals by the main beamformer 38. A beamformer controller 42 provides control signals for the beamformer and microbeamformer. Further details on microbeamformer-controlled scanning of volumetric regions may be found in US Pat. 6,623,432 (Powers et al.), and 6,709,394 (Frisa et al.), PCT publication WO 2005/099579 (Rafter) and US patent application 60/777,831 (Savord), filed March 1, 2006. In this example a user control panel 40 is coupled to the beamformer controller 42 and is operated to control a number of parameters of the scanning of slices 12-16 of the volumetric region 10, including the number of slices to be scanned, the spacing between slices, the number of transmit slices, and the number of receive slices per transmit slice. Referring back to FIGURES 4a-4c, in that example the number of slices to be scanned was four, the spacing between slices was a specified angular or linear parameter, the number of transmit slices was two, and the number of receive slices per transmit slice was two.

[0016] The beamformed echo signals received from the scanned slices are detected by a log detector 52 for B mode imaging. Alternatively or in addition, the received echo signals may be Doppler processed by a Doppler processor 54 for the display of flow or motion in the image field. The B mode image data and the Doppler image data (e.g., Doppler power and/or velocity) of each slice are stored in slice storage buffer 60. Addressing of the buffer 60 to write data into the buffer or read data out of the buffer is controlled by memory controller 62. According to the present invention a plurality of elevationally different slices are read out of the slice storage buffer 60 and combined by a combiner 64.

[0017] The combiner 64 may combine the image data of multiple elevationally different slices in various ways. Combining is preferably performed on image data from different slices which have the same azimuth and depth coordinates in each slice. Alternatively, raylines can be

mathematically projected through the multiple slices in the manner of raycasting for volume rendering. Preferably the raylines are projected normal to the planes of the slices. The image data intersected by each rayline is the data which is combined. In the combining process the image data can be averaged or can be summed and normalized. A mean or median value of the data values can be computed, or a peak value of the data being combined can be used. The data from the central slice is weighted more greatly than the data of neighboring slices, with slice data being weighted in relation to its distance from the central slice. Slice data can be weighted in relation to its proximity to the viewer with slice data in the front of the volume being weighted more greatly than slice data in the back. The combined data thus forms a "thick slice" which can be displayed as a planar display of a slice with characteristics of multiple elevationally offset individual slices. The thick slice data is coupled to an image processor 70 for further processing such as scan conversion into the desired display format (e.g., sector or linear) and is processed into video signals by a video processor 72 for display on a display 76. The image data can also be saved or stored in a CinelooP® memory 78, harddrive or other image storage device. The thick slice display will exhibit reduced speckle artifacts as compared to an individual one of the acquired slices.

[0018] Another example of the present invention is to scan a volume in a coordinate system appropriate for the transducer or for the clinical application. A group of substantially parallel MPR (multi-planar-reformatted) planes are then derived from the acquired volumes, which may be but are not typically aligned with the acquisition slices contained within the volume. These parallel MPR planes are then combined in the aforementioned techniques to produce an MPR thick slice, which is then used to facilitate the visualization of perfusion defects. Such an implementation increases the diagnostic likelihood of detecting infarcted and ischemic regions of the myocardium.

[0019] In accordance with a further aspect of the present invention a high frame rate of display for thick slice images may be obtained by means of the apparatus and techniques depicted in FIGURES 7a and 7b. FIGURE 7a illustrates the slice storage buffer 60 implemented as a dual port memory 160 which can be written to and read from simultaneously. The use of such a R/W memory 160 enables the new data of a slice being scanned by the transducer array and beamformer to be written into one area of the R/W memory while the data of other slices previously stored in the memory is read out and combined to form a thick slice image. The writing of new slice image data into the memory 160 is controlled by a write address controller 162a while the reading of slice image data from other locations in the memory is under the control of a read address controller 162b. In this technique a new thick slice image can be combined for display while the image data from a new slice is being acquired. One example of the allocation of memory for

a combined four-slice thick slice image is illustrated by FIGURE 7b. The storage area 260 of the memory is shown to contain seven image storage areas labeled A through G.

[0020] An example employing the 4X multiline scanning technique of FIGURES 4a-4c for four component slices S_1 - S_4 is as follows. Using the user interface 40, the ultrasound system is set to scan four slices with a given slice spacing, using two transmit slices and two receive slices per transmit slice. Scanning of the first two slices proceeds during a first scanning interval as shown in FIGURES 4a and 4b and the data of the two acquired slices S_1 and S_2 is written into memory areas A and B. Slices S_3 and S_4 are then scanned during a second interval and the data of these two slices is written into memory areas C and D. The transducer array and beamformer then begin to scan slices S_1 and S_2 again and write the data from the rescanning of slices S_1 and S_2 into memory areas E and F. While these slices are rescanned, the image data of memory areas A,B,C, and D is read out of the memory and coupled to the combiner 64 where the individual slice data is combined into a thick slice image. The resultant thick slice image is written into memory area G, from which it is read out and coupled to the image processor (and other components as described below) as needed for processing and display. In a typical implementation the time required to composite the thick slice image and process the image for display will take less time than the time required to rescan slices S_1 and S_2 . After the rescanning of slices S_1 and S_2 is complete, the image data of slices S_1 , S_2 , S_3 , and S_4 which is stored in memory areas C,D,E, and F is read out for combining into a new thick slice image for display, and the new thick slice image is written into memory area G to update the real time thick slice image. Simultaneously, slices S_3 and S_4 are rescanned and their slice data is written into memory areas A and B. In the next scanning interval iteration slices S_1 and S_2 are scanned again and their data written into memory areas C and D while the slice data of memory areas E,F,A, and B is combined to form another thick slice image to update the image in memory area G. This use of 4X multiline for slice acquisition and the combination of new slice data with the most recent data of the other slices of the thick slice image is seen to enable a frame rate of display of the thick slice image which is equal to that of a single slice scanned and displayed by conventional single line scanning. Thus, there would be no degradation of frame rate when changing from conventional single slice imaging to thick slice imaging of four component slices by this technique.

[0021] An implementation of the present invention has been found to be especially useful in colorflow imaging, particular for the detection of small, localized and intermittent flow conditions such as a heart valve jet. Colorflow has long been used in the detection of flow jets from valve leakage, a clinical application for which sensitivity far outweighs precise image resolution. Normally this procedure takes a long time as the clinician slowly moves the

image plane around the heart valve, looking for a short burst of color characteristic of a jet. However, with the system of FIGURE 5, this procedure is considerably enhanced. Since the combiner combines a number of elevationally distinct planes spread over a small volumetric region in elevation, the jet need not occur in the center plane in order to be detected. The occurrence of a jet in the plane of an adjacent slice which is collapsed into the thick slice will enable the jet to be detected even when it is not present in the central slice plane of the thick slice. Furthermore, the jet is more easily detected by the reduction of speckle artifact and color dropout in the thick slice image. While the processing of one of the component slices by the Doppler processor 54 may result in black holes in the colorflow image where destructive interference from the speckle pattern has manifested itself, the differing speckle pattern of the neighboring slice may not exhibit this problem at the same point in the image. Thus, when the colorflow slices are combined in the elevation dimension into the thick slice image, the black hole of one slice may be filled in by valid colorflow of a neighboring slice. The colorflow field will appear smoother and more sensitive to out-of-central plane jets with less far field degradation. Sensitivity of the procedure to jet detection is accordingly enhanced. There are several clinically accepted techniques for using jet area as a means of classifying the severity of pathologic regurgitant flow. The combined color flow thick slice will improve both the qualitative and quantitative outline of the jet, further facilitating the use of techniques for automatically calculating jet area.

[0022] These techniques may be extended to other cardiac applications such as the detection and visualization of coronary arteries. A thick slice image will better display the curved and tortuous paths of coronary arteries around the myocardium than a conventional single slice image. This is the case for contrast images as well as color flow images.

[0023] For the production of a Doppler thick slice image, ensembles of echo signals are received from locations where flow or motion is present and are processed by the Doppler processor 54 to produce a Doppler estimate at those locations. The Doppler estimate may be one of Doppler power at the location, or velocity or variance. Corresponding B mode images may also be acquired if desired so that the Doppler information may be overlaid on structural detail framing the motion. The Doppler slice images are stored in slice storage 60, then combined by combiner 64 using a selected combining technique. Defects in the flow or motion display due to speckle or dropout are thereby reduced, and flow or motion defects in adjacent slice planes are more easily-identified by the projection of multiple Doppler slices in the elevation dimension. Furthermore, since the acquisition of multiple temporally different samples from each flow or motion location will decrease the frame rate of acquisition in the Doppler mode, at least some of this frame rate degradation may be overcome by use of the high speed

thick slice display technique discussed in conjunction with FIGURES 7a and 7b above.

[0024] In accordance with a further aspect of the present invention, the thick slice images are also coupled to an automated or semi-automated border detector (ABD) 80. As is well known, border detectors are used to identify tissue borders in ultrasound images. The border detectors can operate with initial user involvement to identify points on one border in one image, then use that input to automatically identify the full border and the border in other images of a real time image sequence. Other border detectors operate automatically by identifying tissue landmarks in an image then drawing borders using those landmarks. See, for example, US Pats. 6,491,636 (Chenal et al.) and 6,447,453 (Roundhill et al.) and US patent publication 2005/0075567 (Skyba et al.) The border detector 80 identifies a tissue border in a thick slice image with or without user assistance (semi-automated or automated) and couples data identifying the location of the border in one or more thick slice images to a graphics processor 74. The graphics processor 74 creates a graphic outline of the border to the image processor 70 which overlays the identified border over the corresponding thick slice image. It has been found that automated or semi-automated border detection performs better on thick slice images than on comparable single slice images. This is because a tissue border defined by thin tissue which is not a strong reflector of ultrasonic echoes such as the endocardial border of the myocardium can produce a poorly defined tissue border in a single slice image. Image dropout at the border region can produce an ill-defined image border which is difficult to trace reliably by an automated or semi-automated process. In addition, the poorly-defined border can be further disrupted by the image speckle pattern. The combining of elevationally distinct images into a thick slice image can reduce the speckle artifact and make the border more distinct in the image. In addition, missing border segments in one slice can be augmented by identifiable border segments in adjoining slices, causing the consolidated tissue border of the thick slice image to be more clearly defined and hence more reliably processed and identified by the border detector 80.

[0025] In accordance with a further aspect of the present invention, thick slice imaging can be used with ultrasound contrast agents. Ultrasound contrast agents have been approved in the United States for delineation of endocardial borders in difficult-to-image patients. These agents have also proven to be extremely valuable in quantification of volumes and ejection fraction. In several studies, quantification without contrast agents has been shown to underestimate volumes compared to other techniques like MRI. On the other hand, contrast-enhanced images have demonstrated values closer to these techniques. However, previous attempts for automated detection techniques with contrast agents have had limited success. Typically contrast images are acquired with lower power levels to minimize microbubble

destruction - often 10-15dB lower than standard imaging. Consequently the resultant images can have a display dynamic range which is 10 dB or more lower than conventional images without contrast, causing speckle artifact to have a more pronounced adverse impact on the ability to automatically detect endocardial borders.

[0026] In accordance with a further aspect of the present invention, thick slice imaging is used in the diagnosis and quantification of perfusion defects with the aid of ultrasonic contrast agents. When a contrast agent is present in a blood pool such as a blood vessel or chamber of the heart, the contrast agent will generally be present in considerable volume and density in the blood pool. The relatively high concentration of the microbubbles of the contrast agent enable quick and reliable detection of its presence in an ultrasound image. However in perfusion studies such as those conducted with contrast agents to detect poorly perfused tissue such as myocardial tissue which has been infarcted, the contrast agent is only present in small amounts in the tiny capillaries which perfuse the tissue. This low concentration of the microbubbles often makes their detection and quantification difficult or unreliable. This is at a time when high resolution is required since perfusion defects often show up as thin subendocardial regions of slower filling as well as potentially lower blood volume. In addition, perfusion studies are generally conducted at low transmit power levels to avoid breaking or disrupting the microbubbles in the capillary bed and causing them to disappear. Consequently the signal-to-noise ratio of the perfusion images is relatively low, frequently by as much as 20 dB lower than standard imaging techniques, causing further degradation in resolution. The resultant images can have a display dynamic range which is 20 dB or more lower than conventional images without contrast, causing the speckle artifact to have a more pronounced adverse impact on image resolution and the detection of subendocardial regions of poor perfusion.

[0027] Accordingly, contrast images for perfusion diagnosis and/or quantification are improved in accordance with the present invention by scanning multiple planes in the elevation dimension and projecting these multiple elevation slices in the elevation dimension. By performing such operations it is possible to reduce speckle without sacrificing resolution and signal to noise. The methods for compositing or combining slices which have been described above may be employed, including simple averaging and maximum intensity projection, or using compositing techniques from volume rendering (e.g., raycasting). By performing these techniques, the contrast agent speckle will be greatly reduced, subendocardial defects will be more evident, and quantification techniques such as parametric imaging will yield better results. Furthermore, since "destruction-replenishment" techniques require exactly the same elevation slice to be maintained for 10 seconds or more, thick-slice imaging will be more robust in the presence of small movements of the probe, since a plurality of adjacent slices are used

to form the thick slice image plane. Thus, slight movement of the probe to different slice locations will have only minimal effect on the results obtained.

[0028] An ultrasound system constructed in accordance with the principles of the present invention for perfusion studies is shown in block diagram form in FIGURE 6, in which elements previously described in conjunction with FIGURE 5 are identified by the same reference numerals. In this system thick slice images of microbubble-perfused tissue which are produced by the combiner 64 may be processed as B mode images by the image processor 70, the video processor 72, and the display 76 for the display of real time grayscale images of perfusion which exhibit better resolution of tissue perfusion by virtue of reduced speckle caused by the elevational slice combining process. In this example the thick slice contrast images are also coupled to a perfusion detector 90. The perfusion detector 90 may be constructed in the same manner as the contrast signal detector described in PCT publications WO 2005/044108 (Rafter) and WO 2005/099579 (Rafter) to detect and enhance the display of contrast agent perfusion in the images. Alternatively or in addition the perfusion detector may be configured as the contrast signal detector described in US Pat. 6,692,438 (Skyba et al.) to produce a color overlay of the B mode image which depicts perfused tissue in a qualitative color display, or a quantitative display of a perfusion curve or curve parameter for different points in the image.

[0029] The detection of epicardial borders is important to improve accuracy of stress echo exams and for detection of ischemia as well as to facilitate quantification of myocardial mass. However, accurate automatic detection of the epicardium has proven to be elusive. With contrast-enhanced imaging of thick slices, left ventricular opacification and myocardial perfusion improves the ability to detect both the epicardial and endocardial borders, allowing quantification of thickening and myocardial mass.

[0030] FIGURE 8 illustrates an example of an ultrasound system display screen which depicts perfusion using a contrast agent in various ways. In the upper left area of the screen is a thick slice ultrasound image 92 in which the myocardium around the left ventricle has been perfused with a contrast agent as indicated by the light shading. The darker center of the image 92 is the heart chamber. The brighter the shading of the myocardium, the greater the concentration of contrast agent in that region of the myocardium and the better the perfusion of the tissue. To the right of the ultrasound image 92 are four parametric images 94 in which different parameters are displayed related to the perfusion of the myocardium and are depicted in color, with some colors indicating low perfusion and others indicating greater perfusion. Each color corresponds to a particular amount of perfusion depicted by the color bar located between the ultrasound image 92 and the parametric images 94. At the bottom of the screen is an area 96 displaying perfusion curves 98 at the regions marked by the small circles on the right

side myocardium in the thick slice ultrasound image 92. Each perfusion curve 98 represents the rate of reperfusion of a particular region of the myocardium as measured by the reperfusion of microbubbles into the region following a high energy flash disruption of the microbubbles.

[0031] Other variation of the present invention will readily occur to those skilled in the art. For example, the concepts of the present disclosure may be employed in an implementation which does not use multiline acquisition but acquires one receive line for every transmitted scanline. Various sequence of line acquisition may be employed other than successive acquisition of adjacent lines such as those shown in US Pats. 5,438,994 (Starosta et al.) and 5,617,863 (Roundhill et al.) Higher order multiline may be employed than the illustrated 4X multiline, including a multiline order which acquires all of the component slices in one azimuthal scan sequence. Doppler modes other than colorflow may use the present invention including spectral Doppler, flow variance, and color M mode. M mode may use an implementation of the present invention which acquires and combines spatially distinct M lines into one display M line. The techniques of the present invention are applicable to both fundamental and harmonic imaging.

Claims

1. An ultrasonic diagnostic imaging system for the qualitative or quantitative analysis of tissue perfusion comprising:

an array transducer (30) adapted to transmit and receive scanlines over a volumetric region (10) containing tissue which may have a perfusion defect;

a beamformer (36, 38), coupled to the array transducer (30), said beamformer being adapted to produce image data of a plurality of elevationally distinct slices (12-18; 22-24; S_1 - S_4) of the volumetric region (10), said slices being parallel to each other;

a slice memory (60), coupled to the beamformer (36, 38), said memory being configured to store slice image data;

a combiner (64), coupled to the slice memory (60), said combiner being arranged to combine slice image data in the elevation direction (EL) to form an elevationally combined slice image (92) which can be displayed as a planar display of a slice with characteristics of multiple elevationally offset individual slices; and

a display (76);

wherein:

the combiner is further arranged to apply a weighting to the slice image data in the el-

- elevation direction (EL), wherein the weighting is based on a distance from a central slice, with data from the central slice weighted more greatly than the data of neighboring slices;
- the array transducer (30) is arranged to transmit beams, each of which insonifies a plurality of receive line locations of multiple of the plurality of elevationally distinct slices, and arranged to receive echoes from the plurality of receive line locations simultaneously,
- the system further comprises a perfusion detector (90) arranged to operate on the combined slice image data to qualitatively depict perfusion by the concentration of microbubbles in tissue and to produce a quantified perfusion parameter for a region of tissue, wherein
- the display (76) is responsive to the perfusion detector (90) for displaying at least one of the combined slice image (92) with perfusion depicted by color or brightness, or a quantified perfusion parameter for a region of tissue.
2. The ultrasonic diagnostic imaging system of Claim 1, wherein the display (76) is arranged to display the elevationally combined slice image (92) of tissue with perfused areas indicated by brightness.
 3. The ultrasonic diagnostic imaging system of Claim 1, wherein the display (76) is arranged to display a parametric image (94) with different degrees of perfusion indicated by different colors.
 4. The ultrasonic diagnostic imaging system of Claim 1, wherein the display (76) is arranged to display a perfusion curve (98) for a particular region of an elevationally combined slice image (92) of tissue.
 5. The ultrasonic diagnostic imaging system of Claim 1, further comprising a beamformer controller (42) coupled to the beamformer (36, 38), said controller being configured to control the number of slices (12-18; 22-24; S₁-S₄) to be scanned for the elevationally combined slice image (92) .
 6. The ultrasonic diagnostic imaging system of Claim 5, wherein the array transducer (30) is adapted to electronically focus and steer scanlines over the volumetric region (10).
 7. The ultrasonic diagnostic imaging system of Claim 6, wherein the beamformer further comprises a multiline beamformer and the beamformer controller (42) is further arranged to control at least one of the number of transmit scanlines and the number of re-

ceive scanlines per transmit slice.

8. The ultrasonic diagnostic imaging system of Claim 1, wherein the combiner (64) is further arranged to perform at least one of summing slice data in the elevation direction (EL), averaging slice data in the elevation direction (EL), or detecting the maximum value of slice data in the elevation direction (EL).
9. The ultrasonic diagnostic imaging system of Claim 1, wherein the display (76) is responsive to the perfusion detector (90) for producing a perfusion curve (94) or curve parameter for a particular region of contrast agent perfused tissue.

Patentansprüche

1. Ultraschalldiagnostik-Bildgebungssystem für die qualitative oder quantitative Analyse von Gewebepfusion, umfassend:

einen Array-Wandler (30), der angepasst ist, um Scanlinien über eine volumetrische Region (10), die Gewebe enthält, das einen Perfusionsdefekt aufweisen kann, zu übertragen und empfangen;

einen Strahlformer (36, 38), der mit dem Array-Wandler (30) gekoppelt ist, wobei der Strahlformer angepasst ist, um Bilddaten einer Vielzahl von höhenmäßig unterschiedlichen Schnitten (12-18; 22-24; S₁-S₄) der volumetrischen Region (10) zu erzeugen, wobei die Schnitte parallel zueinander sind;

einen Schnittspeicher (60), der mit dem Strahlformer (36, 38) gekoppelt ist, wobei der Speicher konfiguriert ist, um Schnittbilddaten zu speichern;

einen Kombinerer (64), der mit dem Schnittspeicher (60) gekoppelt ist, wobei der Kombinerer angeordnet ist, um Schnittbilddaten in der Höhenrichtung (EL) zu kombinieren, um ein höhenmäßig kombiniertes Schnittbild (92) zu formen, das als eine planare Anzeige eines Schnittes mit Eigenschaften mehrerer höhenmäßig versetzter einzelner Schnitte angezeigt werden kann; und

eine Anzeige (76);

wobei:

der Kombinerer weiter angeordnet ist, um eine Gewichtung auf die Schnittbilddaten in der Höhenrichtung (EL) anzuwenden, wobei die Gewichtung auf einem Abstand von einem Mittelschnitt basiert, wobei Daten vom Mittelschnitt mehr gewichtet sind als die Daten von benachbarten Schnitten;

der Array-Wandler (30) angeordnet ist, um Strahlen zu übertragen, von denen jeder ei-

- ne Vielzahl von Empfangslinienstellen von mehreren der Vielzahl von höhenmäßig unterschiedlichen Schnitten beschallt, und angeordnet, um Echos von der Vielzahl von Empfangslinienstellen gleichzeitig zu empfangen,
das System weiter einen Perfusionsdetektor (90) umfasst, der angeordnet ist, um die kombinierten Schnittbilddaten zu verarbeiten, um eine Perfusion durch die Konzentration von Mikrobläschen in Gewebe qualitativ darzustellen und um einen quantifizierten Perfusionsparameter für eine Geweberegion zu erzeugen, wobei die Anzeige (76) auf den Perfusionsdetektor (90) zum Anzeigen mindestens eines des kombinierten Schnittbildes (92) reagiert, wobei eine Perfusion durch Farbe oder Helligkeit dargestellt wird, oder eines quantifizierten Perfusionsparameters für eine Geweberegion.
2. Ultraschalldiagnostik-Bildgebungssystem nach Anspruch 1, wobei die Anzeige (76) angeordnet ist, um das höhenmäßig kombinierte Schnittbild (92) von Gewebe mit perfundierten Bereichen, die durch Helligkeit angegeben werden, anzuzeigen.
 3. Ultraschalldiagnostik-Bildgebungssystem nach Anspruch 1, wobei die Anzeige (76) angeordnet ist, um ein parametrisches Bild (94) mit verschiedenen Perfusionsgraden, die durch verschiedene Farben angegeben werden, anzuzeigen.
 4. Ultraschalldiagnostik-Bildgebungssystem nach Anspruch 1, wobei die Anzeige (76) angeordnet ist, um eine Perfusionskurve (98) für eine spezifische Region eines höhenmäßig kombinierten Schnittbildes (92) von Gewebe anzuzeigen.
 5. Ultraschalldiagnostik-Bildgebungssystem nach Anspruch 1, weiter umfassend eine Strahlformer-Steuerung (42), die mit dem Strahlformer (36, 38) gekoppelt ist, wobei die Steuerung konfiguriert ist, um die Anzahl von Schnitten (12-18; 22-24; S_1 - S_4), die für das höhenmäßig kombinierte Schnittbild (92) zu scannen sind, zu steuern.
 6. Ultraschalldiagnostik-Bildgebungssystem nach Anspruch 5, wobei der Array-Wandler (30) angepasst ist, um Scanlinien über die volumetrische Region (10) elektrisch scharf zu stellen und zu lenken.
 7. Ultraschalldiagnostik-Bildgebungssystem nach Anspruch 6, wobei der Strahlformer weiter einen Multilinien-Strahlformer umfasst und die Strahlformer-Steuerung (42) weiter angeordnet ist, um mindestens eines von der Anzahl von Übertragungsscanli-

nien und der Anzahl von Empfangsscanlinien pro Übertragungsschnitt zu steuern.

8. Ultraschalldiagnostik-Bildgebungssystem nach Anspruch 1, wobei der Kombinerer (64) weiter angeordnet ist, um mindestens eines von einer Summierung von Schnittdaten in der Höhenrichtung (EL), einer Mittelung von Schnittdaten in der Höhenrichtung (EL) oder einer Detektion des Maximalwertes von Schnittdaten in der Höhenrichtung (EL) durchzuführen.
9. Ultraschalldiagnostik-Bildgebungssystem nach Anspruch 1, wobei die Anzeige (76) auf den Perfusionsdetektor (90) zum Erzeugen einer Perfusionskurve (94) oder eines Kurvenparameters für eine spezifische Region von Kontrastmittelperfundiertem Gewebe reagiert.

Revendications

1. Système d'imagerie de diagnostic ultrasonique pour l'analyse qualitative ou quantitative d'une perfusion de tissu comprenant :

un transducteur en réseau (30) qui est à même de transmettre et de recevoir des lignes de balayage sur une région volumétrique (10) contenant un tissu qui peut avoir un défaut de perfusion ;

une formateur de faisceau (36, 38) couplé au transducteur en réseau (30), ledit formateur de faisceau étant à même de produire des données d'images d'une pluralité de tranches distinctes en hauteur (12-18 ; 22-24 ; S_1 - S_4) de la région volumétrique (10), lesdites tranches étant parallèles l'une à l'autre ;

une mémoire de tranches (60) couplée au formateur de faisceau (36, 38), ladite mémoire étant configurée pour stocker des données d'images de tranches ;

un combineur (64) couplé à la mémoire de tranches (60), ledit combineur étant agencé pour combiner des données d'images de tranches dans le sens de la hauteur (EL) pour former une image de tranches combinées en hauteur (92) qui peut être affichée sous la forme d'un affichage planaire d'une tranche ayant les caractéristiques de multiples tranches individuelles décalées en hauteur ; et
un appareil d'affichage (76) ;
dans lequel :

le combineur est en outre agencé pour appliquer une pondération aux données d'images de tranches dans le sens de la hauteur (EL), dans lequel la pondération est

- basée sur une distance depuis une tranche centrale, les données de la tranche centrale étant pondérées plus fortement que les données de tranches voisines ;
 le transducteur en réseau (30) est agencé pour transmettre des faisceaux dont chacun insonorise une pluralité d'emplacements de lignes réceptrices de multiples tranches de la pluralité de tranches distinctes en hauteur et agencé pour recevoir des échos de la pluralité d'emplacements de lignes réceptrices simultanément,
 le système comprend en outre un détecteur de perfusion (90) agencé pour opérer sur les données d'images de tranches combinées afin de décrire qualitativement la perfusion par la concentration de microbulles dans le tissu et produire un paramètre de perfusion quantifié pour une région du tissu, dans lequel :
 l'appareil d'affichage (76) est sensible au détecteur de perfusion (90) pour afficher au moins l'une de l'image de tranches combinées (92) avec une perfusion décrite par la couleur ou la brillance, ou d'un paramètre de perfusion quantifié pour une région du tissu.
2. Système d'imagerie de diagnostic ultrasonique selon la revendication 1, dans lequel l'appareil d'affichage (76) est agencé pour afficher l'image de tranches combinées en hauteur (92) du tissu avec des zones perfusées indiquées par la brillance. 30
 3. Système d'imagerie de diagnostic ultrasonique selon la revendication 1, dans lequel l'appareil d'affichage (76) est agencé pour afficher une image paramétrique (94) avec différents degrés de perfusion indiqués par différentes couleurs. 35
 4. Système d'imagerie de diagnostic ultrasonique selon la revendication 1, dans lequel l'appareil d'affichage (76) est agencé pour afficher une courbe de perfusion (98) pour une région particulière d'une image de tissu (92) de tranches combinées en hauteur. 40
 5. Système d'imagerie de diagnostic ultrasonique selon la revendication 1, comprenant en outre un dispositif de commande de formateur de faisceau (42) couplé au formateur de faisceau (36, 38), ledit dispositif de commande étant configuré pour commander le nombre de tranches (12-18 ; 22-24 ; S₁-S₄) à balayer pour l'image de tranches combinées en hauteur (92). 45
 6. Système d'imagerie de diagnostic ultrasonique selon la revendication 5, dans lequel le transducteur en réseau (30) est à même de focaliser et d'orienter par voie électronique des lignes de balayage sur la région volumétrique (10). 50
 7. Système d'imagerie de diagnostic ultrasonique selon la revendication 6, dans lequel le formateur de faisceau comprend en outre un formateur de faisceau multilinéaire et le dispositif de commande (42) du formateur de faisceau est en outre agencé pour commander au moins l'une du nombre de lignes de balayage de transmission et du nombre de lignes de balayage de réception par tranche de transmission. 55
 8. Système d'imagerie de diagnostic ultrasonique selon la revendication 1, dans lequel le combineur (64) est en outre agencé pour effectuer au moins l'une de la sommation de données de tranches dans le sens de la hauteur (EL), de la prise de moyenne des données de tranches dans le sens de la hauteur (EL) ou de détection de la valeur maximale de données de tranches dans le sens de la hauteur (EL).
 9. Système d'imagerie de diagnostic ultrasonique selon la revendication 1, dans lequel l'appareil d'affichage (76) est sensible au détecteur de perfusion (90) pour produire une courbe de perfusion (94) et un paramètre de courbe pour une région particulière d'un tissu perfusé par un agent de contraste.

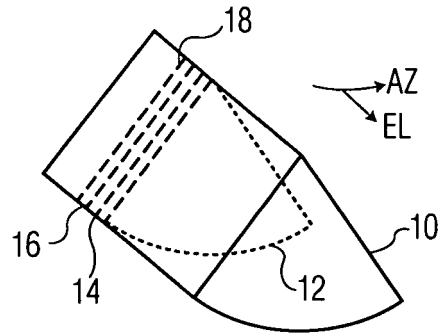

FIG. 1

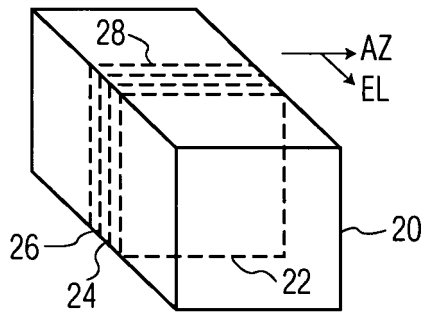

FIG. 2

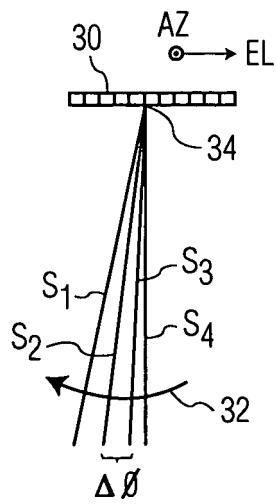

FIG. 3

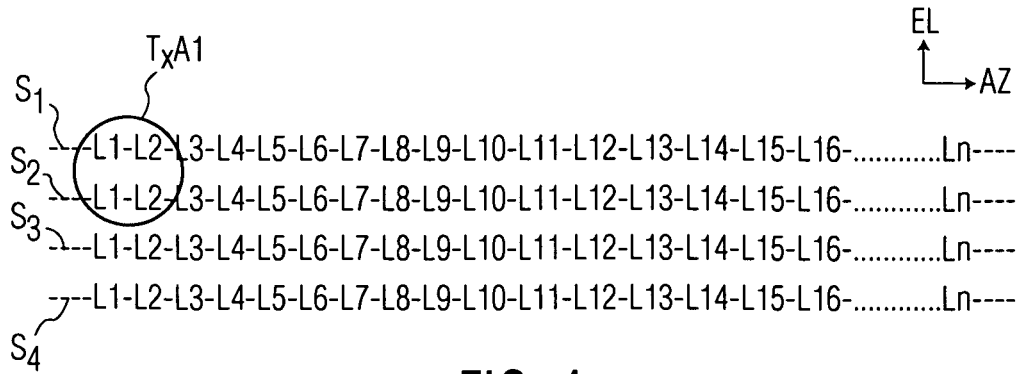

FIG. 4a

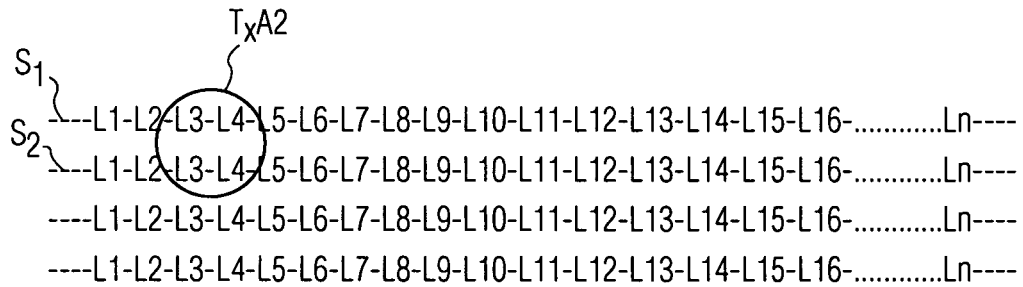

FIG. 4b

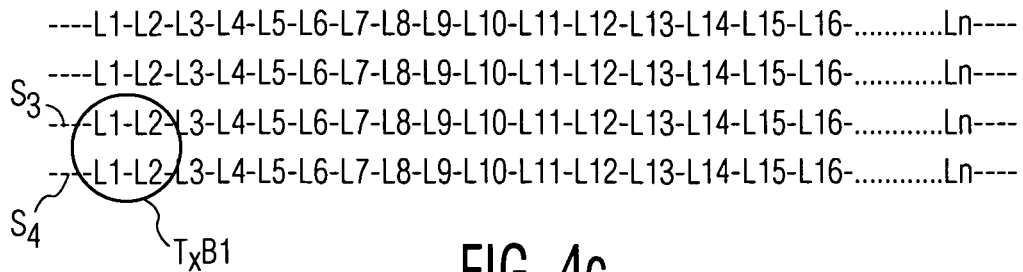

FIG. 4c

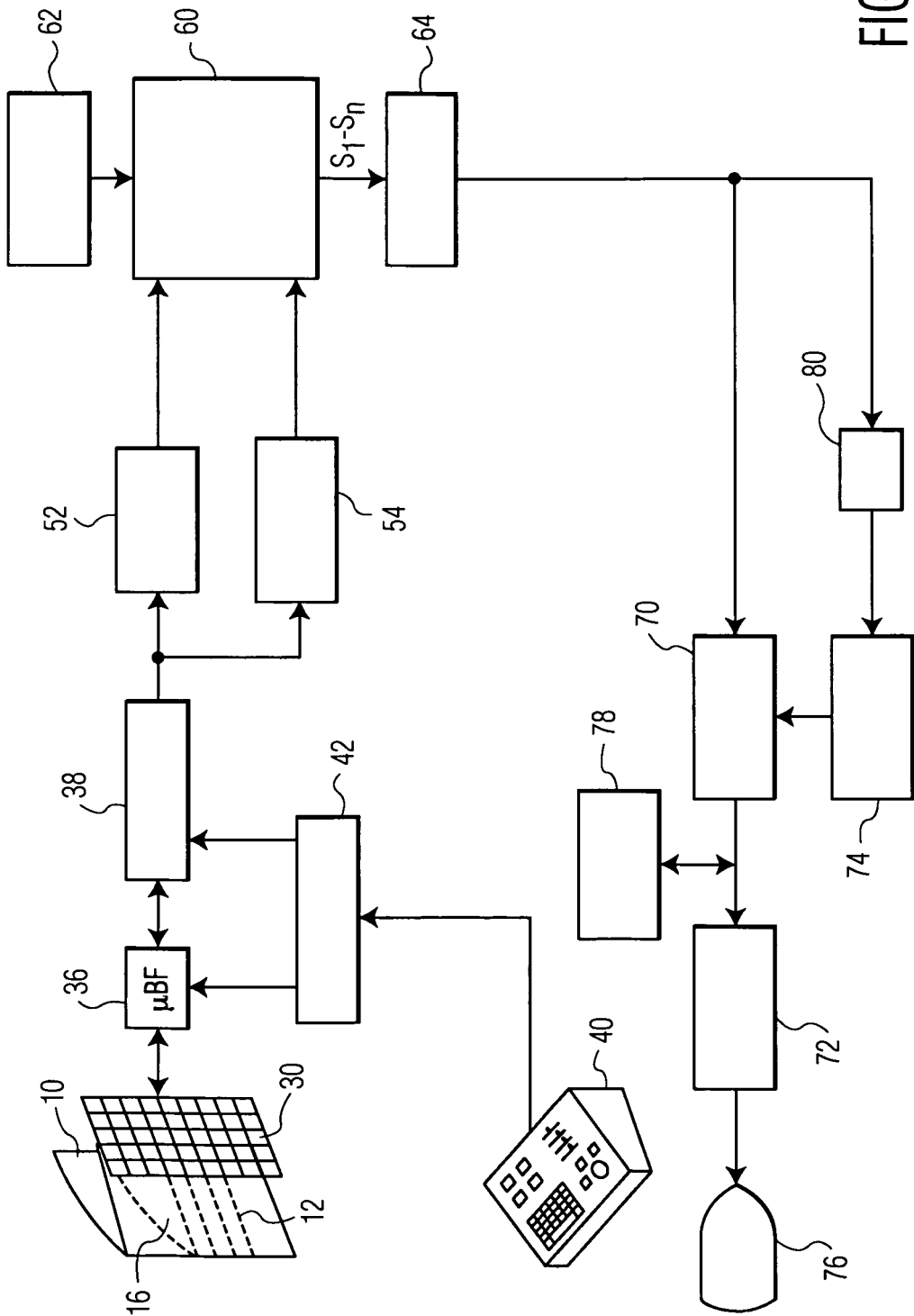

FIG. 5

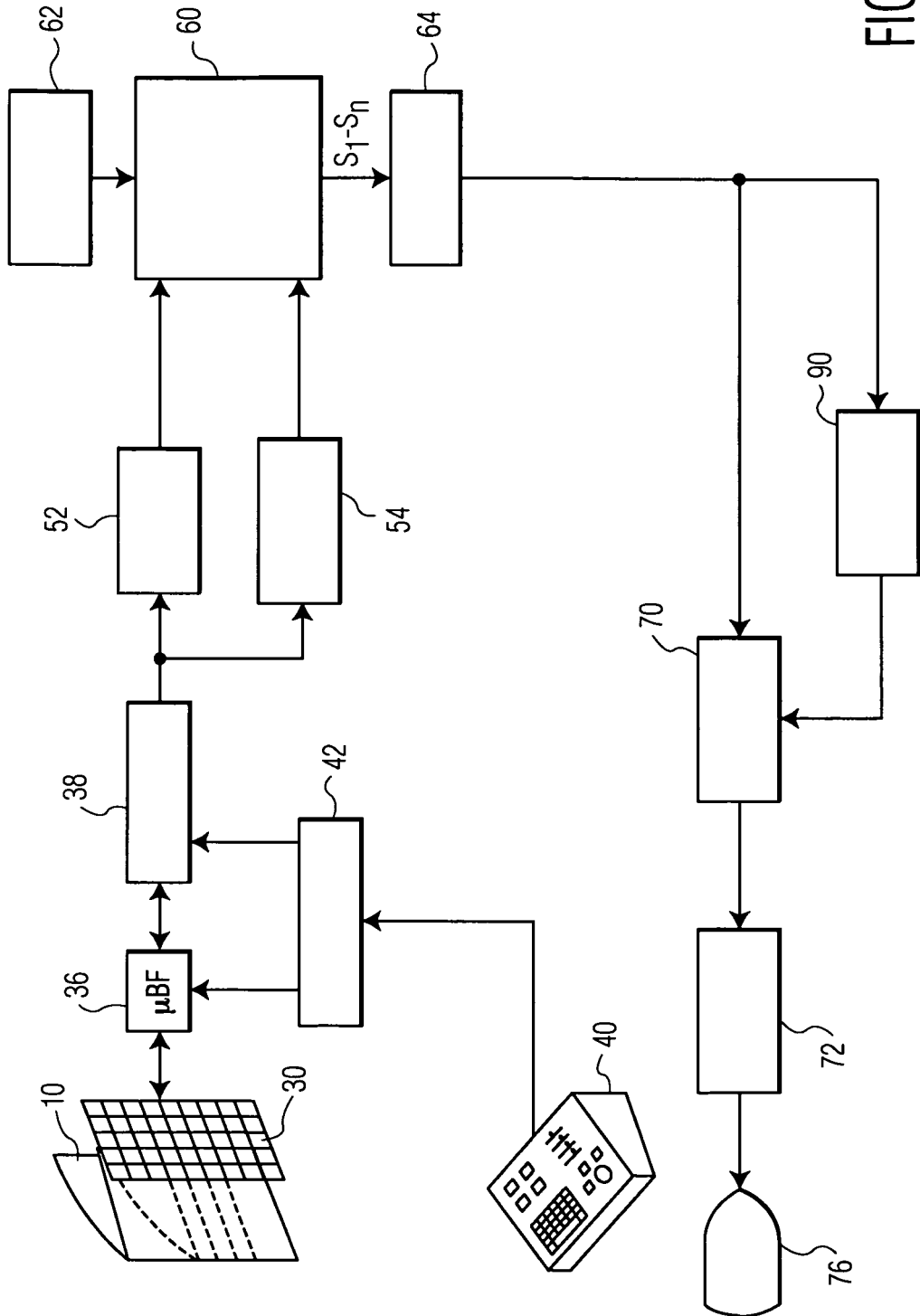

FIG. 6

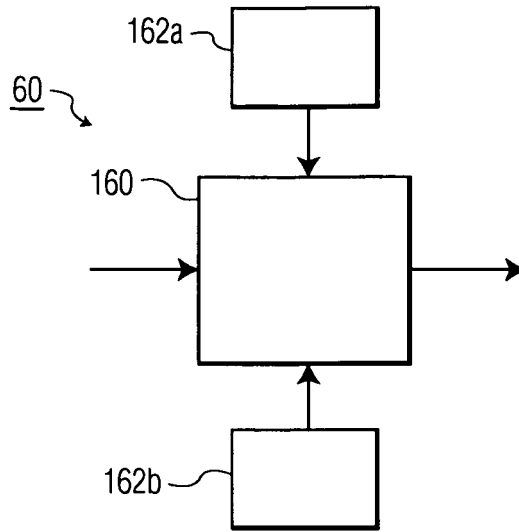

FIG. 7a

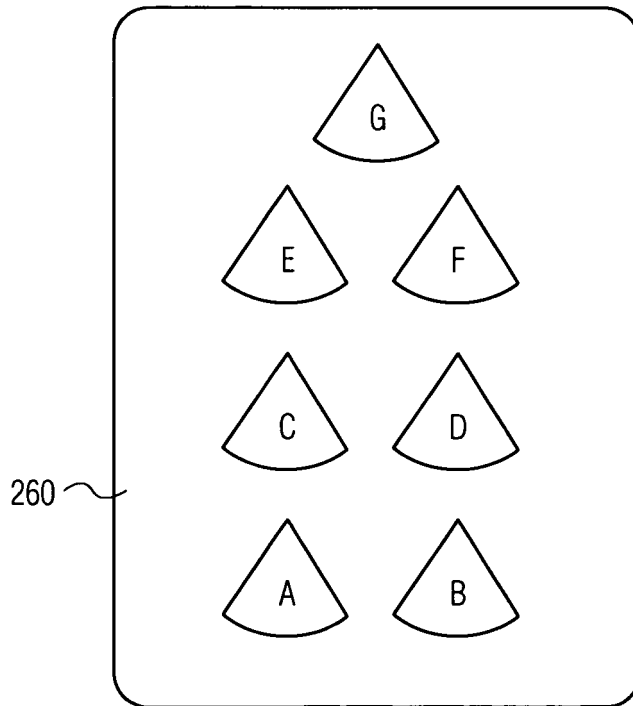

FIG. 7b

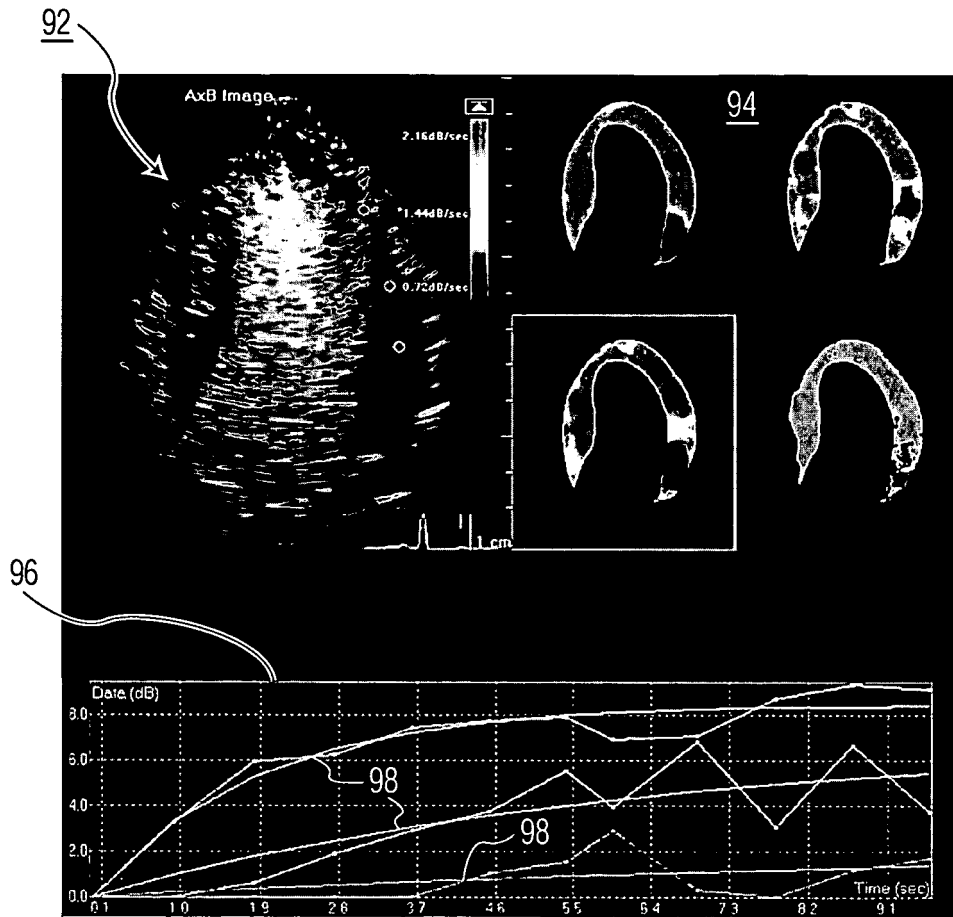

FIG. 8

REFERENCES CITED IN THE DESCRIPTION

This list of references cited by the applicant is for the reader's convenience only. It does not form part of the European patent document. Even though great care has been taken in compiling the references, errors or omissions cannot be excluded and the EPO disclaims all liability in this regard.

Patent documents cited in the description

- US 4350917 A, Lizzi [0004]
- US 4649927 A, Fehr [0004]
- WO 2005072617 A1 [0005]
- US 20050075567 A1 [0006]
- US 6464638 B, Adams [0007]
- US 5318033 A, Savord [0014]
- US 6623432 B, Powers [0015]
- US 6709394 B, Frisa [0015]
- WO 2005099579 A, Rafter [0015]
- US 60777831 B, Savord [0015]
- US 6491636 B, Chenal [0024]
- US 6447453 B, Roundhill [0024]
- US 20050075567 A, Skyba [0024]
- WO 2005044108 A, Rafter [0028]
- WO 2005099579 PCT, Rafter [0028]
- US 6692438 B, Skyba [0028]
- US 5438994 A, Starosta [0031]
- US 5617863 A, Roundhill [0031]

专利名称(译)	超声厚切片成像定量灌注研究		
公开(公告)号	EP2134262A2	公开(公告)日	2009-12-23
申请号	EP2008745338	申请日	2008-04-09
[标]申请(专利权)人(译)	皇家飞利浦电子股份有限公司		
申请(专利权)人(译)	皇家飞利浦电子N.V.		
当前申请(专利权)人(译)	皇家飞利浦电子N.V.		
[标]发明人	RAFTER PATRICK G THIELE KARL BURNHAM ROBERT L		
发明人	RAFTER, PATRICK, G. THIELE, KARL BURNHAM, ROBERT, L.		
IPC分类号	A61B8/14		
CPC分类号	A61B8/06 A61B8/0883 A61B8/463 A61B8/481 A61B8/483 A61B8/5223 A61B8/5253 A61B8/5269 G01S7/5208 G01S15/8925		
优先权	60/911598 2007-04-13 US		
其他公开文献	EP2134262B1 EP2134262A4		
外部链接	Espacenet		

摘要(译)

超声诊断成像系统扫描包含已由造影剂灌注的组织的体积区域中的多个平面切片。扫描的多个切片彼此平行。在检测到切片的图像数据之后，通过在高程维度中投影数据来组合切片数据，以产生高度组合的切片图像。组合可以通过平均或最大强度检测或加权过程或通过体积渲染过程中的高程维度中的光线投射来进行。处理高度组合的切片图像以产生灌注的定性或定量测量，例如由一系列亮度水平指示的具有灌注程度的图像，颜色灌注参数的图像，或指示灌注曲线或曲线参数的灌注曲线或曲线参数。灌注。