

(19)



(11)

EP 1 684 638 B1

(12)

EUROPEAN PATENT SPECIFICATION

(45) Date of publication and mention of the grant of the patent:
16.05.2018 Bulletin 2018/20

(51) Int Cl.:
A61B 8/00 ^(2006.01) **A61B 8/06** ^(2006.01)
G10K 11/34 ^(2006.01)

(21) Application number: **04798756.5**

(86) International application number:
PCT/IB2004/003570

(22) Date of filing: **01.11.2004**

(87) International publication number:
WO 2005/044108 (19.05.2005 Gazette 2005/20)

(54) METHOD FOR ULTRASOUND PERFUSION IMAGING

VERFAHREN FÜR DIE ULTRASCHALL-PERFUSIONSDARSTELLUNG

PROCEDE D'IMAGERIE DE PERFUSION PAR ULTRASON

(84) Designated Contracting States:
AT BE BG CH CY CZ DE DK EE ES FI FR GB GR HU IE IS IT LI LU MC NL PL PT RO SE SI SK TR

• **RAFTER, Patrick**
Bothell, Washington 98041-3003 (US)

(30) Priority: **07.11.2003 US 518277 P**

(74) Representative: **Roche, Denis et al**
Société Civile SPID
33, rue de Verdun
92150 Suresnes (FR)

(43) Date of publication of application:
02.08.2006 Bulletin 2006/31

(73) Proprietor: **Koninklijke Philips N.V.**
5656 AE Eindhoven (NL)

(56) References cited:
WO-A1-2004/041091 US-A- 5 860 931
US-A- 5 944 666 US-B1- 6 340 348

(72) Inventors:
• **AVERKIOU, Michalakis**
Bothell, Washington 98041-3003 (US)

Note: Within nine months of the publication of the mention of the grant of the European patent in the European Patent Bulletin, any person may give notice to the European Patent Office of opposition to that patent, in accordance with the Implementing Regulations. Notice of opposition shall not be deemed to have been filed until the opposition fee has been paid. (Art. 99(1) European Patent Convention).

EP 1 684 638 B1

Description

[0001] This invention relates to ultrasound imaging systems, and, more particularly, to a system and method for obtaining ultrasound perfusion images in a manner that provides more rapid and accurate depictions of tissue perfusion and its quantification.

[0002] Ultrasound imaging systems are widely used to obtain a variety of ultrasound images. The imaging systems may be used to scan different parts of the body using a variety of different techniques or imaging modalities. For example, an ultrasound scanhead may transmit ultrasound into tissues beneath the scanhead and detect ultrasound reflections from the tissues from several different directions. The resulting image, known as a compound ultrasound image, can provide more accurate depictions of curved surfaces, and it has relatively little speckle. Harmonic ultrasound imaging can be performed by transmitting ultrasound energy having a fundamental frequency and detecting ultrasound reflections from tissues beneath a scanhead at harmonic frequencies. For either compound imaging or harmonic imaging, as well as conventional imaging, the scanhead may be scanned across tissues of interest to provide an extended field of view or panoramic image.

[0003] Ultrasound images depicting blood flow can be enhanced by the use of ultrasonic contrast agents. In contrast agents, gases, in the form of tiny bubbles called "microbubbles" are injected into the bloodstream of a patient. Microbubbles present a significant acoustic impedance mismatch in the body, thereby reflecting transmitted ultrasound to a significantly greater degree than red blood cells. As a result, microbubbles are conventionally used as contrast agents to improve the definition of blood flow. Microbubbles are typically small bubbles of gas coated with a thin biodegradable coating or shell. These coated microbubbles typically have diameters between 0.1 and 4.0 microns and a specific density about 1/10 of the density of water. Coated microbubbles are normally suspended in an aqueous solution for infusion into the blood stream. Coated microbubbles have the advantage of being stable in the body for a significant period of time, as the shells serve to protect the gases of the microbubbles from diffusion into the bloodstream. The size of the microbubbles may be chosen to enable the microbubbles to pass through the capillary bed in the body. Therefore, microbubble contrast agents, whether coated or uncoated, can be used for imaging the body's vascularized tissues, such as the walls of the heart, since the contrast agent can be injected into the bloodstream and will pass through veins, arteries and capillaries with the blood supply until filtered from the blood stream in the lungs, kidneys and liver.

[0004] Although coated and uncoated microbubbles can survive in the body for an extended period, they can also be selectively destroyed. More specifically, at moderately high sound pressure amplitudes within FDA limits, acoustic pressure waves can cause microbubbles to rup-

ture, freeing the gas to quickly diffuse into the bloodstream.

[0005] Contrast agents are frequently used in perfusion studies to assess the ability of vasculature to replenish tissue with a new supply of blood. Two types of perfusions studies are known as "high MI" studies and "low MI" studies, where MI refers to the mechanical index (intensity) of the transmitted acoustic pressure wave. In high MI studies, a series of high MI triggered image frames are acquired. The high MI pulses of the image frames are synchronized to the heart cycle with an EKG gate, respiratory gate or other gating (triggering) signal so that the resultant image will brightly show the amount of bloodflow which has reperfused tissue since the previous image frame. The image is formed with the microbubble destruction signals and shows the location of microbubbles at the time of destruction. The intensity of the image is proportional to the destruction events. See for example US patent 5,457,257 (Johnson et al.) which describes a differential two-pulse high MI technique. In low MI studies the imaging pulses have small amplitudes such that the microbubbles are not destroyed and there is no need for triggering the transmit signals. For quantification of blood flow in the microcirculation an initial high MI frame referred to as a "flash" frame is transmitted to destroy the microbubbles currently in the tissue of the image. After the microbubbles in a region of interest have been destroyed, the blood that contained the destroyed microbubbles flows out of tissues in the region of interest, and new blood containing microbubbles re-perfuses these tissues. Ultrasound pulses having magnitudes that are insufficient to destroy microbubbles in the blood re-perfusing the tissues are then periodically transmitted into the region of interest, and resulting echo signals are obtained. As the density of the microbubbles increases with the re-perfusion of the tissues with blood containing microbubbles, the intensity of echoes from the region of interest increases. The manner in which the intensity of the echoes increases provides an indication of tissue perfusion, which can be seen in the low MI images produced from these echoes. A low rate of tissue perfusion in certain areas may provide an indication of abnormal medical condition, such as, for example, a blockage of blood flow in the heart. By depicting tissue reperfusion in this manner on a spatial basis, a parametric image can be obtained which shows the perfusion rate at various locations in tissues being imaged. For example, an image may be obtained showing a cross-section of the left ventricle that has been color-coded to show the perfusion rate in the myocardium, i.e., the walls of the left ventricle.

[0006] One conventional technique for obtaining ultrasound perfusion images is shown in Figure 1. A phased array transducer 10 sequentially transmits several high intensity beams 12a-n of ultrasound into vascularized tissues 14 of interest. The intensity of the ultrasound is sufficient to break or destroy microbubbles in the area of the tissues 14 that is insonified by each beam 12a-n. The transducer 10 thereafter transmits several beams 12a-n

of ultrasound having an intensity that is insufficient to destroy microbubbles in the insonified tissues 14. This relatively low intensity ultrasound is reflected by the microbubbles which have re-entered the tissues 14, and the reflections are received by the transducer 10. The low intensity ultrasound is repetitively transmitted and resulting ultrasound reflections detected over a sufficient period of time for the tissues to re-perfuse, and the detected ultrasound is used to generate a series of ultrasound perfusion images. A similar ultrasound system and method is for example disclosed in US 5,944,666 or in US 5,860,931.

[0007] One problem with the technique shown in Figure 1 is that it can take a considerable period to destroy all of the microbubbles in the tissues 14. More specifically, the microbubbles in the tissues 14 insonified by the beam 12a are destroyed first followed by the microbubbles insonified by the beam 12b, and so forth, until the microbubbles insonified by the beam 12n are finally destroyed. This beam-by-beam destruction of microbubbles is especially disadvantageous when doing three dimensional (3D) imaging, where the time required to transmit many beams over a volume of tissue can take an appreciable amount of time. As a result, the 3D frame rate can be significantly degraded. Another problem is uneven microbubble destruction at different depths. The depth where the high intensity beams come into focus will experience greater acoustic pressures than shallower or deeper depths, resulting in greater microbubble destruction in the focal region. A more uniform destruction at all depths would be more desirable for better reperfusion imaging and quantification.

[0008] The problems caused by the uneven destruction of microbubbles using the technique shown in Figure 1 has been addressed by using another technique that will be explained with reference to Figure 2. A phased array transducer 20 transmits a single plane wave beam 22 of ultrasound energy having an intensity that is sufficient to destroy the microbubbles in vascularized tissues 24 insonified by the beam 22. For high MI imaging a series of high MI plane waves are transmitted and the returning echo signals beamformed to produce a sequence of high MI images. For low MI imaging a series of low MI plane waves are transmitted, and the returning echoes are beamformed to produce a sequence of low MI images. While this technique addresses the aforementioned problems, it suffers from low resolution and imprecise quantification due to the lack of any focused transmit beamformation and resultant high side lobe levels. Moreover, while the technique performs well for steady state flow analysis, it does not address the needs of quantified reperfusion studies.

[0009] There is therefore a need for a system and method that can accurately depict blood perfusion in tissues, and provides high accuracy and speed in quantified reperfusion studies.

[0010] According to present invention there is provided an ultrasound imaging method as claimed in claim 1.

[0011] In the drawings:

Figure 1 is a schematic view illustrating one technique that is conventionally used for ultrasound perfusion imaging.

Figure 2 is a schematic view illustrating another technique that is conventionally used for ultrasound perfusion imaging.

Figures 3A and 3B are schematic views illustrating a technique for ultrasound perfusion imaging according to one embodiment of the invention.

Figures 4A and 4B are schematic views illustrating a technique for ultrasound perfusion imaging (not part of the invention).

Figures 5A and 5B are schematic views illustrating a technique for generating a three-dimensional or volume ultrasound perfusion image according to one embodiment of the invention.

Figure 6 is a block diagram of an imaging system that can be used for ultrasound perfusion imaging using the technique shown in Figures 3-5.

[0012] One embodiment of a technique for ultrasound perfusion imaging in accordance with the invention is shown in Figures 3A and 3B. With reference to Figure 3A, a phased array transducer 30 transmits a single broad (not part of the invention) or plane wave beam 32 of ultrasound energy having an intensity that is sufficient to destroy microbubbles in vascularized tissues 34 insonified by the beam 32. As a result, re-perfusion of the entire area of interest in the tissues 34 starts at the same time. However, unlike the technique of Figure 2, a plurality of single plane wave beams of low intensity ultrasound energy are not used for imaging purposes. Instead, as shown in Figure 3B, the transducer 30 transmits several beams 36a-n of ultrasound having an intensity that is insufficient to destroy microbubbles in the insonified tissues 34. This relatively low intensity ultrasound is reflected by the microbubbles in the tissues 34, and the reflections are received by the transducer 30 in receive beams 36a-n that coincide with the beams 36a-n of transmitted ultrasound. As a result, the transmitted ultrasound is directed only into areas of the tissues 34 that coincide with the areas from which ultrasound reflections are detected. Consequently the round-trip beam profile of the imaging ultrasound is well focused and resolved, enabling the production of high resolution images and precise reperfusion quantification.

[0013] In another embodiment (not being part of the invention) illustrated in Figure 4A, a phased array transducer 40 sequentially transmits several high intensity broad ultrasound beams 42a-c into vascularized tissues 44 beneath the transducer 40 to destroy microbubbles in areas of the tissues 44 insonified by the beams 42a-c. Thereafter, as shown in Figure 4B, ultrasound imaging beams 46a-n of low intensity (to avoid microbubble destruction) are sequentially transmitted, and ultrasound reflections are detected in received imaging beams 46a-

n that coincide with the transmitted imaging beams 46a-n in the same manner as shown in Figure 3B. The embodiment of Figures 4A and 4B has the disadvantage of destroying the microbubbles in the tissues 44 at different times. However, since only a few microbubble-destroying beams 42a-c are used, the microbubbles insonified by each of the beams 42a-c are destroyed at times that are sufficiently close to each other that tissue perfusion can be accurately portrayed. The use of microbubble-destroying beams 42a-c that are significantly wider than the transmitted imaging beams 46a-n thus causes the microbubbles to be destroyed at essentially the same time, and the resultant echoes may or may not be used for imaging depending upon the needs of the user.

[0014] The quick destruction of the microbubbles is also aided by the rapid rate at which the microbubble-destroying beams 42a-c can be transmitted. Specifically, the microbubble-destroying beams 42a-c can be transmitted at a high rate because it is not necessary to wait for reflections from one transmitted beam 42a-c to reach the transducer 40 before the next beam 42a-c can be transmitted. Since it is not necessary to wait for returning echo signals in this embodiment before transmitting the next microbubble-destroying beam, the microbubble-destroying beams can be transmitted in a burst in rapid, immediate succession along the transducer aperture. By comparison, in the technique illustrated in Figure 1, the second microbubble-destroying beam 12b cannot be transmitted until reflections from the first imaging beam 12a have been received. It is primarily for this reason, that the prior art technique shown in Figure 1 cannot destroy all of the microbubbles at substantially the same time. In distinction, using the technique shown in Figures 4A and 4B, the microbubble-destroying beams 42a-c can be transmitted right after each other. This technique of rapid firing may generally be performed by standard imaging systems without the need for extensive modifications.

[0015] The perfusion imaging techniques shown in Figures 3A, 3B and 4A, 4B use one-dimensional transducer arrays that generate a beam that is used for two-dimensional B-scan perfusion imaging. It will be appreciated that the imaging beams of the embodiments described may be steered in a linear, sector, or steered linear pattern, using a phased array, linear array, curved array or other transducer format. In a similar manner to the preceding embodiments, a 2-dimensional transducer array can be used to generate beams that can be used for three-dimensional or volume perfusion imaging. With reference to Figure 5A, a two-dimensional transducer array 50 transmits a single, two-dimensional plane-wave beam 52 into vascularized tissues 54 containing microbubbles. The transmitted beam 52 has sufficient power to destroy all of the microbubbles in the tissue volume 54. Thus, all of the microbubbles in the tissues are destroyed at the same time. In another embodiment (not part of the invention), rather than using a single microbubble-destroying beam 52, separate two-dimensional plane-wave beams,

e.g., three beams, are transmitted into the tissues 54 in a manner analogous to the use of separate one-dimensional microbubble-destroying beams 42 as shown in Figure 4A. The use of separate microbubble-destroying beams transmitted either sequentially or simultaneously enables the selection and control of microbubble-destruction in different subvolumes in front of the transducer aperture. The microbubble-destroying beams can be differently steered to destroy microbubbles in differently angled subvolumes, for instance.

[0016] Regardless of whether a single microbubble-destroying beam or multiple microbubble-destroying beams are used, after the microbubbles have been destroyed, the two-dimensional transducer array 50 transmits a series of imaging beams 56a-n as shown in Figure 5B. After each imaging beam 56a-n is transmitted, reflections from the tissues 54 and microbubbles in the reperfed tissues 54 are detected in received imaging beams 56a-n that are coincident with the transmitted imaging beams 56a-n. The received imaging beams 56a-n are then processed to provide a three-dimensional or volume image showing the rate of perfusion in the tissues 54. It will be understood that the present invention can also be practiced with multiline systems, in which the imaging beams comprise a "fat" transmit beam or multiple, simultaneous differently steered transmit beams followed by the reception of multiple simultaneous receive beams for imaging. Multiple microbubble-destroying beams can also be transmitted simultaneously with a multiline transmitter (not part of the invention). These multiple microbubble-destroying beams can all be steered in the same direction, e.g., straight ahead, or can be steered in different transmit directions or angles. For example, three microbubble destroying beams can be transmitted at the same time, with one transmitted at an angle to the transducer of -20° , a second transmitted at an angle of 0° , and a third transmitted at an angle of $+20^\circ$.

[0017] The area or volume of microbubble destruction can be controlled in several ways (not all forming part of the invention). One is to change the focusing of the microbubble destruction beams. A beam can be an unfocused plane wave or a weakly focused beam with a focal point below the maximum depth of the image, or a more strongly focused beam. Another way to control the microbubble destruction region is by changing the aperture size, that is, transmitting with fewer or a greater number of transducer elements of the array transducer. A third way to control the microbubble destruction region is by control of the transmit apodization, that is, the weighting functions applied to the transmit channels of the transmit aperture. These area or volume control techniques can be used together in various combinations. Either unfocused destruction beams or weakly focused destruction beams (where the focus is placed in the far field, beyond the maximum image depth) or combinations thereof may be employed (not all forming part of the invention). Unfocused beams do not use delays between different elements of the array transducer and weakly focused

beams only use small delays between element or between only a small number of elements. Also, although the microbubble-destroying beams, as well as the transmitted and received imaging beams in the illustrated embodiments are not shown steered from side to side, it will be understood that steered beams may alternatively be used. Finally, perfusion imaging in other embodiments may be performed in combination with other ultrasound imaging techniques, such as compound imaging, tissue harmonic imaging, Doppler flow imaging, and panoramic imaging, to name a few.

[0018] One embodiment of an ultrasonic diagnostic imaging system 100 that can generate perfusion images using the embodiments shown in Figures 3-5, as well as other embodiments of the invention, is shown in Figure 6. The imaging system 100 includes an ultrasound scan-head 110 having a two-dimensional transducer array 112 that transmits ultrasonic energy and receives echoes in response to the ultrasound transmission. For imaging microbubbles, nonlinear imaging techniques are often desirable. In the event harmonic imaging is used, the response characteristic of the transducer can exhibit two passbands, one around the central transmit frequency and another about the center of the received passband. For imaging harmonic contrast agents, a broadband transducer having a passband encompassing both the transmit and receive passbands may be used. Pulse inversion and amplitude modulation techniques may be used for harmonic separation, such as those described in US patents 5,706,819 (Hwang) and 5,577,505 (Brock-Fisher).

[0019] The imaging system 100 also includes a central controller 120 that provides a control signal f_{tr} to a transmit frequency control circuit 117 to control the center frequency and time of transmission of the transmitted ultrasound. The transmit frequency control circuit 117 pulses the elements of the transducer array 112 by means of a transmit/receive switch 114. As explained above with reference to Figures 3-5, the transducer array 112 is initially pulsed in one or more microbubble-destroying bursts followed by transmission of a relatively large number of imaging beams.

[0020] Echoes received by the transducer array 112 from a relatively large number of received imaging beams are coupled through the T/R switch 114 and digitized by analog-to-digital ("A/D") converters 115. The sampling frequency f_s of the A/D converters 115 is controlled by the central controller 120. The desired sampling rate is dictated by sampling theory and is at least twice the highest frequency f_c of the received passband. Sampling rates higher than the minimum requirement are also desirable.

[0021] The transmitting and receiving of imaging beams is repeated at intervals that allow time for blood containing microbubbles to gradually infuse the vessels and tissues of interest. The frame rate of these transmissions can be on the order of one-thirtieth of a second, and can be gated to the heart rate. In any case, the sam-

ples of signals from the transducer array 112 are delayed and summed by a beamformer 116 to form coherent echo signals. The digital coherent echo signals are then filtered by a digital filter 118. In the embodiment of Figure 6, the relationship between the transmit frequency f_t and the received frequency is not fixed, and hence a band of frequencies may be received that is different from the transmitted band of frequencies. Thus, the received frequencies may be harmonics of the transmitted frequencies. The digital filter 118 bandpass filters the signals in a predetermined passband, and may also shift the frequency band to a lower or baseband frequency range.

[0022] The filtered signals from the digital filter 118 may be coupled to a B-mode processor 137 for conventional B-mode processing. Filtered echo signals of the contrast agent passband are coupled to a contrast signal detector 128, which eliminates stationary tissue signals by pulse-to-pulse subtraction of temporally discrete echoes from a given spatial location, amplitude or envelope detects the resulting difference signals, and discriminates for motion signal components on an amplitude basis. Simple two pulse subtraction of the form P1-P2 may be employed, where P1 represents the echoes received following one pulse and P2 represents the echoes received following another pulse. Alternatively the contrast agent may be detected by B-mode processing or Doppler processing.

[0023] Respective outputs from the B-mode processor 137 and the contrast signal detector 128 are coupled to a 3D image rendering processor 132 for the rendering of three-dimensional images, which are stored in a 3D image memory 134. Three dimensional rendering may be performed as described in U.S. Patent Nos. 5,720,291; 5,474,073 and 5,485,842, which are incorporated herein by reference. The signals from the contrast signal detector 128 and the B-mode processor 137, and the three dimensional image signals from the 3D image memory 134, are coupled to a video processor 140 where they may be selected for display on an image display 150 as dictated by user selection.

[0024] In operation, the perfusion image shown in the display 150 is able to accurately portray and quantify the reperfusion of tissues because all of the microbubbles in the tissues are destroyed at essentially the same time. The use of focused and/or weakly focused beams for imaging results in good resolution in the resultant contrast images.

[0025] Although Figure 6 illustrates one embodiment of the invention, it will be understood that different embodiments may be used, and components may be added to or subtracted from the components shown in Figure 6 to provide an imaging system that is capable of providing ultrasound perfusion images in accordance with the various embodiments disclosed herein or hereafter developed.

Claims

1. A method of obtaining an ultrasound perfusion image of tissues perfused with blood containing microbubbles, the method comprising:

transmitting a single unfocused plane wave beam (32, 52) of microbubble-destroying ultrasound into the tissues by means of an ultrasound scanhead (110) having a one-dimensional or two-dimensional array (30, 50, 112) of transducer elements, wherein for generating the unfocused plane wave beam (32, 52) no delays are used between different transducer elements of the transducer array (30, 50, 112), the unfocused plane wave beam (32, 52) encompassing a first area of the tissues, the microbubble-destroying ultrasound having an intensity that is sufficient to destroy all of the microbubbles in the tissues that are insonified by the microbubble-destroying ultrasound;

repetitively transmitting a plurality of beams of imaging ultrasound into the tissues, each beam of imaging ultrasound having a second area that is smaller than the first area, the imaging ultrasound having an intensity that is insufficient to destroy microbubbles in the tissues that are insonified by the imaging ultrasound;

receiving reflections from each of the transmitted imaging ultrasound beams in respective receive beams, each of the receive beams having a third area that is smaller than the first area; and processing the received reflections over a sufficient period to allow reperfusion of the tissues to provide an ultrasound perfusion image.

2. The method of claim 1 wherein the act of repetitively transmitting a plurality of beams of imaging ultrasound into the tissues and receiving reflections from each of the transmitted imaging ultrasound beams comprises transmitting the beams of imaging ultrasound into the tissues at a first frequency and receiving reflections from the transmitted imaging ultrasound beams at a second frequency that is a harmonic of the first frequency.

3. The method of claim 1 wherein the size of each second area insonified by a respective transmitted imaging beams is substantially equal to the size of the respective third area from which reflections from each of the transmitted imaging ultrasound beams are received.

Patentansprüche

1. Verfahren zum Erhalten eines Ultraschall-Durchblutungsbildes von Geweben, die von Mikrobläschen

enthaltendem Blut durchblutet werden, wobei das Verfahren umfasst:

Senden eines einzelnen unfokussierten, ebenen Wellenstrahls (32, 52) von Mikrobläschen zerstörendem Ultraschall in die Gewebe mittels eines Ultraschall-Abtastkopfes (110), der eine eindimensionale oder zweidimensionale Anordnung (30, 50, 112) von Wandlerelementen aufweist, wobei zum Erzeugen des unfokussierten ebenen Wellenstrahls (32, 52) keine Verzögerungen zwischen verschiedenen Wandlerelementen der Wandleranordnung (30, 50, 112) verwendet werden, wobei der unfokussierte ebene Wellenstrahl (32, 52) eine erste Fläche der Gewebe umschließt, wobei der Mikrobläschen zerstörende Ultraschall eine Intensität aufweist, die ausreichend ist, um alle der Mikrobläschen in den Geweben, die von dem Mikrobläschen zerstörenden Ultraschall beschallt werden, zu zerstören;

wiederholtes Senden einer Vielzahl von Bildgebungs-Ultraschallstrahlen in die Gewebe, wobei jeder Bildgebungs-Ultraschallstrahl eine zweite Fläche aufweist, die kleiner ist als die erste Fläche, wobei der Bildgebungs-Ultraschall eine Intensität aufweist, die nicht ausreichend ist, um Mikrobläschen in den Geweben, die von dem Bildgebungs-Ultraschall beschallt werden, zu zerstören;

Empfangen von Reflektionen von jedem der gesendeten Bildgebungs-Ultraschallstrahlen in jeweiligen Empfangsstrahlen, wobei jeder der Empfangsstrahlen eine dritte Fläche aufweist, die kleiner ist als die erste Fläche; und Verarbeiten der empfangenen Reflektionen über einen ausreichenden Zeitraum, um Wiederdurchblutung der Gewebe zu ermöglichen, um ein Ultraschall-Durchblutungsbild bereitzustellen.

2. Verfahren nach Anspruch 1, wobei der Vorgang des wiederholten Sendens einer Vielzahl von Bildgebungs-Ultraschallstrahlen in die Gewebe, und Empfangens von Reflektionen von jedem der gesendeten Bildgebungs-Ultraschallstrahlen das Senden der Bildgebungs-Ultraschallstrahlen in die Gewebe auf einer ersten Frequenz, und Empfangens von Reflektionen von den gesendeten Bildgebungs-Ultraschallstrahlen auf einer zweiten Frequenz umfasst, die eine Harmonische der ersten Frequenz ist.

3. Verfahren nach Anspruch 1, wobei die Größe jeder von einem jeweiligen gesendeten Bildgebungsstrahlen beschallten zweiten Fläche im Wesentlichen gleich der Größe der jeweiligen dritten Fläche ist, von der Reflektionen von jedem der gesendeten Bildgebungs-Ultraschallstrahlen empfangen wer-

den.

des réflexions de chacun des faisceaux d'ultrasons d'imagerie transmis sont reçues.

Revendications

- 5
1. Procédé d'obtention d'une image de perfusion par ultrasons de tissus perfusés par des microtubules contenant du sang, le procédé comprenant :
- 10 la transmission d'un faisceau d'ondes planes non focalisé unique (32, 52) d'ultrasons détruisant des microtubules dans les tissus au moyen d'une tête de balayage à ultrasons (110) ayant une série monodimensionnelle ou bidimensionnelle (30, 50, 112) d'éléments de transducteur, dans lequel pour générer le faisceau d'ondes planes non focalisé (32, 52), aucun délai n'est appliqué entre différents éléments de transducteur de la série de transducteur (30, 50, 112), le faisceau d'ondes planes non focalisé (32, 52) comprenant une première zone des tissus, les ultrasons détruisant des microtubules ayant une intensité qui est suffisante pour détruire tous les microtubules dans les tissus qui sont insonifiés par les ultrasons détruisant des microtubules ; 15 20 25 30 35 40
- la transmission répétée d'une pluralité de faisceaux d'ultrasons d'imagerie dans les tissus, chaque faisceau d'ultrasons d'imagerie ayant une deuxième zone qui est plus petite que la première zone, les ultrasons d'imagerie ayant une intensité qui est insuffisante pour détruire des microtubules dans les tissus qui sont insonifiés par les ultrasons d'imagerie ;
- la réception de réflexions de chacun des faisceaux d'ultrasons d'imagerie transmis dans des faisceaux de réception respectifs, chacun des faisceaux de réception ayant une troisième zone qui est plus petite que la première zone ; et
- le traitement des réflexions reçues sur une période suffisante pour permettre une reperfusion des tissus pour donner une image de perfusion par ultrasons.
- 45
2. Procédé selon la revendication 1, dans lequel l'acte de transmission répétée d'une pluralité de faisceaux d'ultrasons d'imagerie dans les tissus et de réception de réflexions de chacun des faisceaux d'ultrasons d'imagerie transmis comprend la transmission des faisceaux d'ultrasons d'imagerie dans les tissus à une première fréquence et la réception de réflexions des faisceaux d'ultrasons d'imagerie transmis à une deuxième fréquence qui est une harmonique de la première fréquence. 50
- 55
3. Procédé selon la revendication 1, dans lequel la taille de chaque deuxième zone insonifiée par un faisceau d'imagerie transmis respectif est sensiblement égale à la taille de la troisième zone respective de laquelle

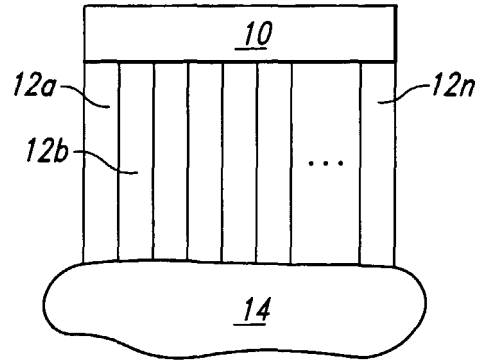

Fig. 1
(Prior Art)

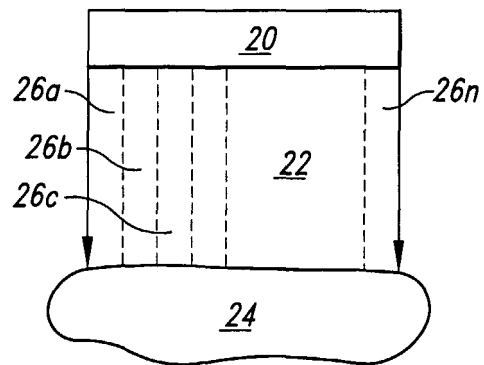

Fig. 2
(Prior Art)

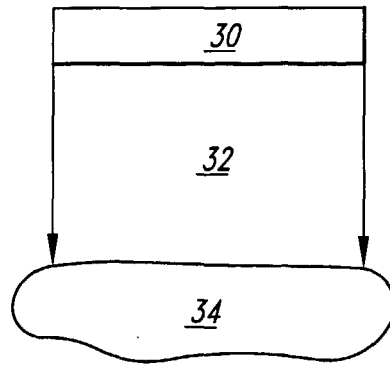

Fig. 3A

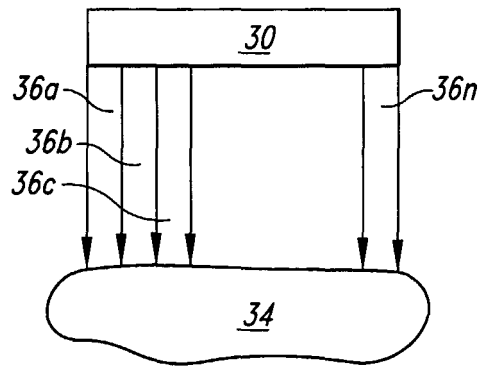

Fig. 3B

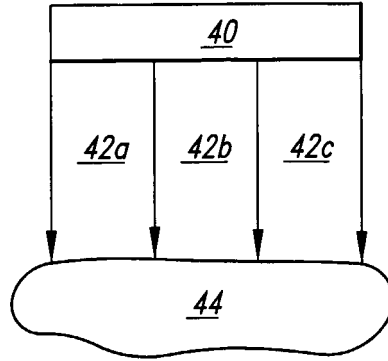

Fig. 4A

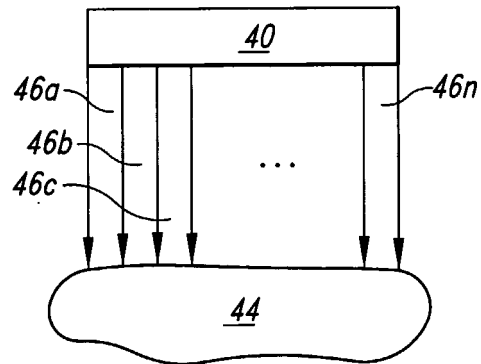

Fig. 4B

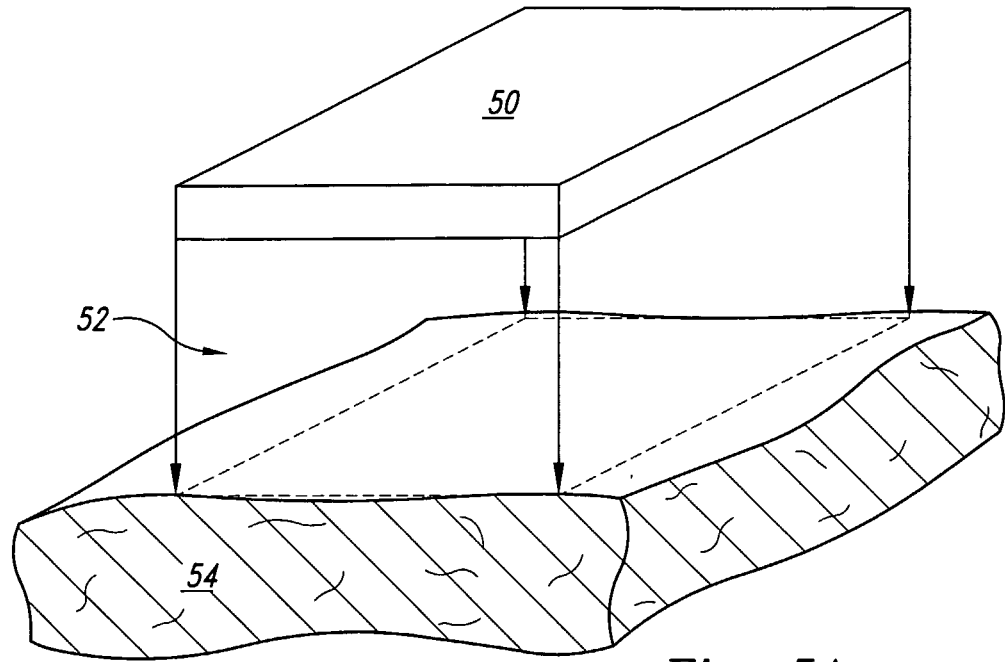

Fig. 5A

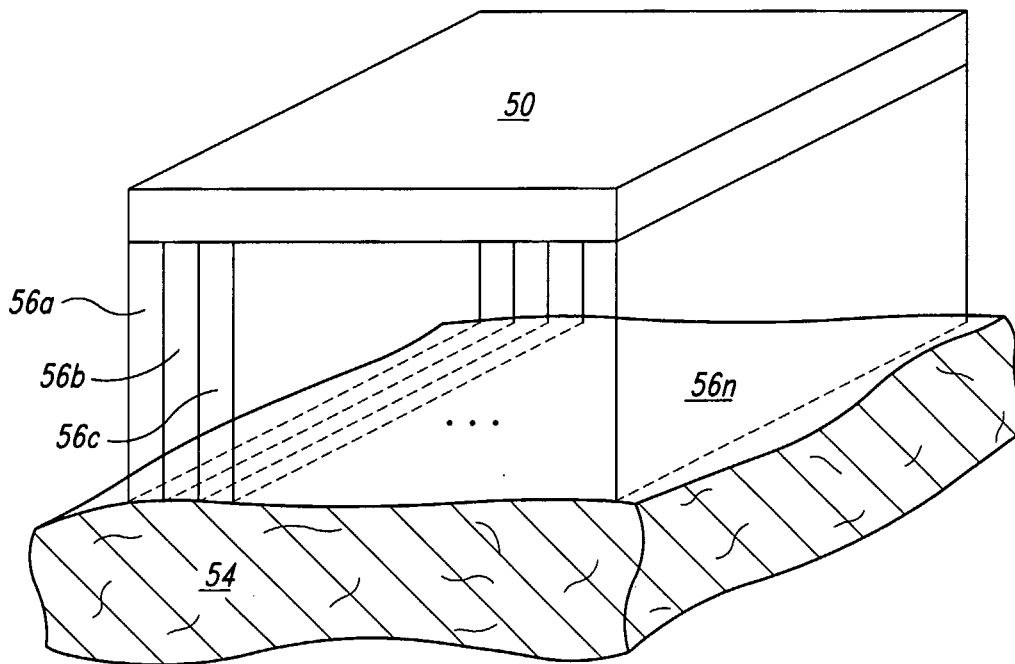

Fig. 5B

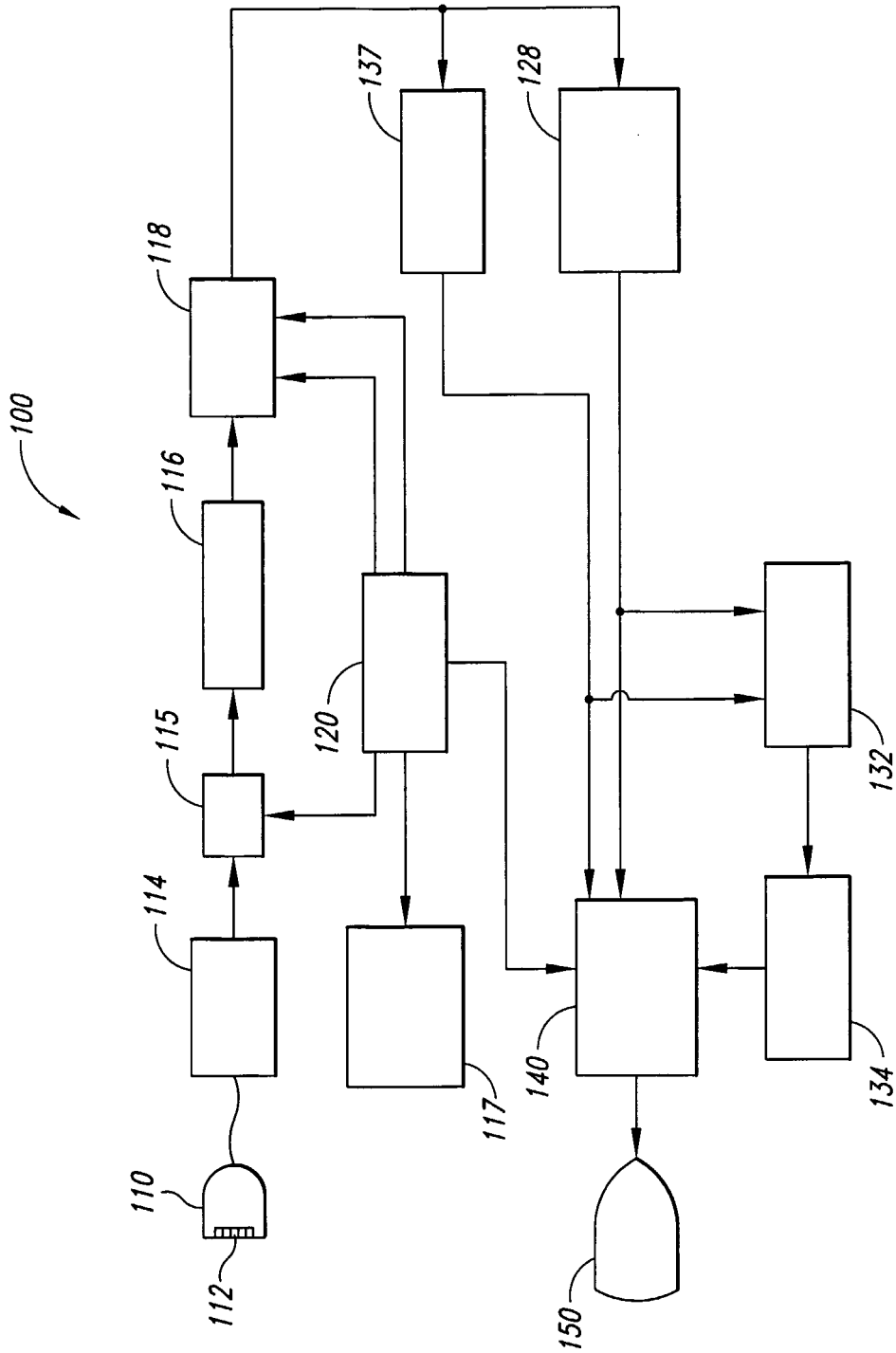

Fig. 6

REFERENCES CITED IN THE DESCRIPTION

This list of references cited by the applicant is for the reader's convenience only. It does not form part of the European patent document. Even though great care has been taken in compiling the references, errors or omissions cannot be excluded and the EPO disclaims all liability in this regard.

Patent documents cited in the description

- US 5457257 A, Johnson **[0005]**
- US 5944666 A **[0006]**
- US 5860931 A **[0006]**
- US 5706819 A, Hwang **[0018]**
- US 5577505 A, Brock-Fisher **[0018]**
- US 5720291 A **[0023]**
- US 5474073 A **[0023]**
- US 5485842 A **[0023]**

专利名称(译)	超声灌注成像的方法		
公开(公告)号	EP1684638B1	公开(公告)日	2018-05-16
申请号	EP2004798756	申请日	2004-11-01
[标]申请(专利权)人(译)	皇家飞利浦电子股份有限公司		
申请(专利权)人(译)	皇家飞利浦电子N.V.		
当前申请(专利权)人(译)	皇家飞利浦N.V.		
[标]发明人	AVERKIOU MICHALAKIS RAFTER PATRICK		
发明人	AVERKIOU, MICHALAKIS RAFTER, PATRICK		
IPC分类号	A61B8/00 A61B8/06 G10K11/34 F22B37/14 G01H3/00		
CPC分类号	A61B8/06 A61B8/481 A61B8/543 G01H3/00 G10K11/346		
代理机构(译)	ROCHE , DENIS		
优先权	60/518277 2003-11-07 US		
其他公开文献	EP1684638A1		
外部链接	Espacenet		

摘要(译)

超声成像系统将宽束超声波发射到用含有微泡的血液灌注的组织中。超声波的强度足以破坏组织中的微泡。然后，在足够的时间段内将多个超声成像光束传输到组织中以允许组织重新灌注，并且处理来自所传输的成像光束的反射以提供灌注图像。所传输的微泡破坏超声波可以是单个光束或多个光束的形式，其声透射比由透射的成像光束声穿透的区域大得多的区域。结果，微泡全部基本上同时被破坏，并且成像超声仅被传输到将从其接收超声反射的组织区域。

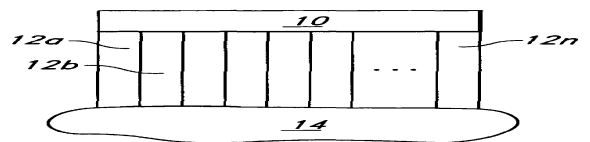

Fig. 1
(Prior Art)

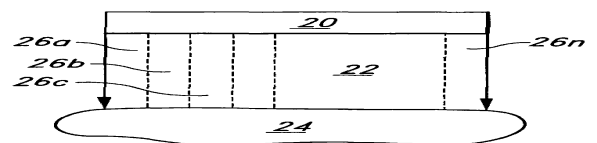

Fig. 2
(Prior Art)