



(43) International Publication Date
28 September 2017 (28.09.2017)

(51) International Patent Classification:

A61B 8/14 (2006.01) G01S 15/89 (2006.01)
A61B 5/026 (2006.01)

(21) International Application Number:

PCT/IB2016/051579

(22) International Filing Date:

21 March 2016 (21.03.2016)

(25) Filing Language:

English

(26) Publication Language:

English

(71) Applicant: **ULTRASONIX MEDICAL CORPORATION** [CA/CA]; #130-4311 Viking Way, Richmond, British Columbia V6V2K9 (CA).

(72) Inventors: **MILES, Brandon**; 213-9311 Alexandra Rd., Richmond, British Columbia V6V2K9 (CA). **ZAHIRI, Reza**; 688 Abbott Street, Apt. 2206, Vancouver, British Columbia V5P 2P5 (CA). **ESKANDARI, Hani**; 2008 Bayswater, Apt. 302, Vancouver, British Columbia V6K 4A8 (CA).

(81) Designated States (unless otherwise indicated, for every kind of national protection available): AE, AG, AL, AM, AO, AT, AU, AZ, BA, BB, BG, BH, BN, BR, BW, BY, BZ, CA, CH, CL, CN, CO, CR, CU, CZ, DE, DK, DM, DO, DZ, EC, EE, EG, ES, FI, GB, GD, GE, GH, GM, GT,

HN, HR, HU, ID, IL, IN, IR, IS, JP, KE, KG, KN, KP, KR, KZ, LA, LC, LK, LR, LS, LU, LY, MA, MD, ME, MG, MK, MN, MW, MX, MY, MZ, NA, NG, NI, NO, NZ, OM, PA, PE, PG, PH, PL, PT, QA, RO, RS, RU, RW, SA, SC, SD, SE, SG, SK, SL, SM, ST, SV, SY, TH, TJ, TM, TN, TR, TT, TZ, UA, UG, US, UZ, VC, VN, ZA, ZM, ZW.

(84) Designated States (unless otherwise indicated, for every kind of regional protection available): ARIPO (BW, GH, GM, KE, LR, LS, MW, MZ, NA, RW, SD, SL, ST, SZ, TZ, UG, ZM, ZW), Eurasian (AM, AZ, BY, KG, KZ, RU, TJ, TM), European (AL, AT, BE, BG, CH, CY, CZ, DE, DK, EE, ES, FI, FR, GB, GR, HR, HU, IE, IS, IT, LT, LU, LV, MC, MK, MT, NL, NO, PL, PT, RO, RS, SE, SI, SK, SM, TR), OAPI (BF, BJ, CF, CG, CI, CM, GA, GN, GQ, GW, KM, ML, MR, NE, SN, TD, TG).

Declarations under Rule 4.17:

- as to the identity of the inventor (Rule 4.17(i))
- as to applicant's entitlement to apply for and be granted a patent (Rule 4.17(ii))
- of inventorship (Rule 4.17(iv))

Published:

- with international search report (Art. 21(3))

(54) Title: VISUALIZATION OF ULTRASOUND VECTOR FLOW IMAGING (VFI) DATA

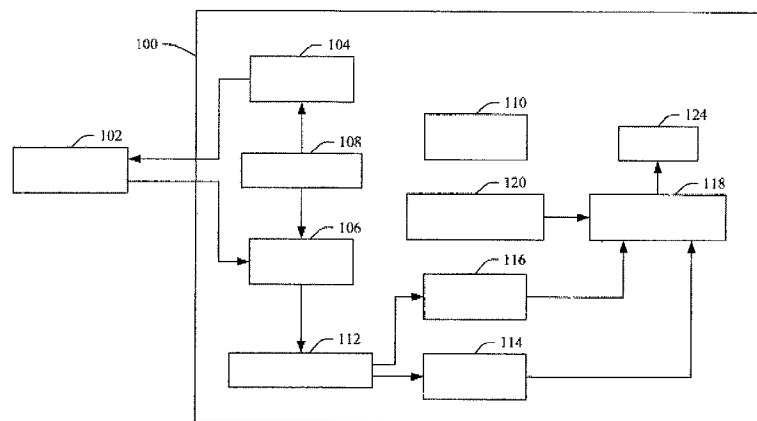
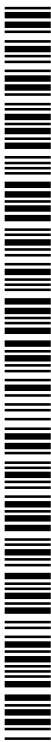

FIGURE 1

(57) Abstract: A method of ultrasound imaging includes transmitting an ultrasound signal with an ultrasound transducer array. The method further includes receiving from the ultrasound transducer array electrical signals indicative of ultrasound echoes received by the ultrasound transducer array. The method further includes beamforming the electrical signals, which results in beamformed data. The method further includes processing the beamformed data, which generates an image. The image represents at least an anatomical vessel of interest. The method further includes processing the beamformed data, which generates flow direction data and flow magnitude data for blood cells flowing in a predetermined region of the anatomical vessel. The method further includes processing the flow direction data and the flow magnitude data, which creates a visualization of the flow direction data and the flow magnitude data for the entire predetermined region of the vessel. The method further includes visually presenting the image with the visualization superimposed thereover.



WO 2017/163103 A1

Visualization of Ultrasound Vector Flow Imaging (VFI) Data

TECHNICAL FIELD

The following generally relates to ultrasound imaging and more particularly to
5 visualization of ultrasound vector flow imaging (VFI) data.

BACKGROUND

Ultrasound imaging provides information about the interior of a subject. For
example, ultrasound imaging can be used to generate an image of a blood vessel and
10 estimate blood flow velocity of blood cells inside the blood vessel. One approach to
estimating the blood flow velocity is vector flow imaging (VFI). VFI provides a direction
and magnitude of the flow at every point in the image. This is in contrast to conventional
color flow measurements that only provide a speed of flow along a single axis. Different
VFI techniques have been introduced as a means to measure and display blood flow. VFI
15 data contains detailed information on how the flow moves or changes over time. VFI can
provide more complete information of the flow such as vortices, flow reversal and flow
direction changes across the vessel.

Turbulent flow visualization is also used for diagnosing medical conditions. For
example, patent ductus arteriosus, which occurs when the ductus arteriosus (a connection
20 between the pulmonary artery and aorta) fails to close postnatally, is diagnosed by
noticing a retrograde color flow jet in a Doppler flow image. Similarly, the quality of flow
in an arteriovenous fistula (AVFs) is monitored frequently to measure the direction of flow
and to diagnose any turbulent flow in the region. Guidelines have recommended that such
monitoring be performed on all mature arteriovenous fistulas (AVFs) on a weekly basis
25 and prior to starting dialysis for each patient. Making turbulent flow easier to visualize
has the potential to make such monitoring and diagnosis easier and more effective.

Real-time visualization for VFI includes 1-D color coding based on magnitude of
flow combined with arrows on a grid that show local direction of the flow, and 2-D color
coding methods that show both magnitude and direction of flow with colors while using
30 arrows as an additional information to show the direction and the magnitude. These
methods introduce limitations when flow is complex and dynamic as they are inherently
local. They are local in that they only display flow information at a single point without

providing a global view of the flow. They are static in that they only show static flow information at each time point, as opposed to information about the dynamics of flow over time. It is also difficult to visualize turbulent flow with existing methods. Moreover, 2-D color maps are not intuitive and are difficult to interpret for the end user, and they are not well-suited for concurrently visualizing magnitude and direction of flow.

Methods that employ contours and fixed arrows have similar limitations when it comes to complex and dynamic flow since they are local and static. B-Flow imaging (BFI) has also been used for visualization of flow. In BFI, ultrasound speckle patterns are directly visualized to show the movement of the blood. BFI does not offer vector flow measurement quantitatively, just visualization of motion. Vector Flow Mapping uses stationary arrows to show the flow vector which is another local visualization method. Vector Projectile Imaging combines high frame rate imaging with moving arrows showing flow. This method is not suitable for real-time visualization since the data needs to be acquired using ultrafast imaging and processed offline. Pathlet visualization requires ultrafast imaging with 2-D speckle tracking to acquire vector data. However, it is not suitable for real-time visualization since data needs to be acquired using ultrafast imaging.

SUMMARY

Aspects of the application address the above matters, and others.

In one aspect, a method of ultrasound imaging includes transmitting an ultrasound signal with an ultrasound transducer array. The method further includes receiving from the ultrasound transducer array electrical signals indicative of ultrasound echoes received by the ultrasound transducer array. The method further includes beamforming the electrical signals, which results in beamformed data. The method further includes processing the beamformed data, which generates an image. The image represents at least an anatomical vessel of interest. The method further includes processing the beamformed data, which generates flow direction data and flow magnitude data for blood cells flowing in a predetermined region of the anatomical vessel. The method further includes processing the flow direction data and the flow magnitude data, which creates a visualization of the flow direction data and the flow magnitude data for the entire predetermined region of the vessel. The method further includes visually presenting the image with the visualization superimposed thereover.

In another aspect, a computer readable storage medium is encoded with computer readable instructions, which, when executed by a processor, cause the processor to: receive, from an ultrasound transducer array, electrical signals indicative of ultrasound echoes received by the ultrasound transducer array, generate beamformed data by
5 beamforming the electrical signals, generate an image by processing the beamformed data, generate vector flow imaging data by processing the beamformed data, wherein the vector flow imaging data includes a flow direction data and a flow magnitude data for blood cells flowing in a predetermined region of an anatomical vessel, create a visualization of the flow direction data and the flow magnitude data for the entire predetermined region of the
10 vessel with the vector flow imaging data, and display the image with the visualization overlaid thereover.

In another aspect, an ultrasound imaging console includes receive circuitry (106) configured to receive from an ultrasound transducer array electrical signals indicative of ultrasound echoes received by the ultrasound transducer array. The console further
15 includes a beamformer configured to beamform the electrical signals. The console further includes an image processor configured to generate an image by processing the beamformed electrical signals. The console further includes a vector flow imaging processor configured to determine a flow direction and a flow magnitude by processing the beamformed electrical signals using a vector flow imaging algorithm. The console
20 further includes a visualization processor configured to generate a visualization of the determined flow direction and of the flow magnitude. The console further includes a display configured to display the generated image with the generated visualization of the determined flow direction and of the flow magnitude superimposed over the displayed image.

25 Those skilled in the art will recognize still other aspects of the present application upon reading and understanding the attached description.

BRIEF DESCRIPTION OF THE DRAWINGS

The application is illustrated by way of example and not limited by the figures of
30 the accompanying drawings, in which like references indicate similar elements and in which:

Figure 1 schematically illustrates an example ultrasound imaging console with at least a VFI processor and a visualization processor;

Figure 2 illustrates an example of a B-mode image;

Figure 3 illustrates an example MPMS visualization with gray scale representing flow magnitude and arrows representing global flow;

Figure 4 illustrates an example of the B-mode image of Figure 2 with the MPMS visualization of Figure 3 superimposed thereover;

Figure 5 illustrates an example of a B-mode image;

Figure 6A illustrates an example of flow direction arrows representing local flow at single points;

Figure 6B illustrates an example flow magnitude color map;

Figure 7 illustrates a prior art example with the B-mode image of Figure 5 with the flow direction arrows of Figure 6A and the flow magnitude color map of Figure 6B superimposed thereover;

Figure 8 illustrates an example of a B-mode image;

Figure 9 illustrates an example DIS visualization with gray scale representing flow magnitude and streamlines, created via line integral convolution algorithm with white noise, representing global flow;

Figure 10 illustrates an example of the B-mode image of Figure 8 with the DIS visualization of Figure 9 superimposed thereover;

Figure 11 illustrates an example of a B-mode image;

Figure 12 illustrates an example DIS visualization with gray scale representing flow magnitude and streamlines, created via line integral convolution algorithm with sparse noise, representing global flow;

Figure 13 illustrates an example of the B-mode image of Figure 11 with the DIS visualization of Figure 12 superimposed thereover;

Figure 14 illustrates an example of a B-mode image;

Figure 15 illustrates an example DIS visualization with gray scale representing flow magnitude and streaklines, created via line integral convolution algorithm with white noise, representing global flow;

Figure 16 illustrates an example of the B-mode image of Figure 14 with the DIS visualization of Figure 15 superimposed thereover;

A controller 108 controls one or more of the transmit circuitry 104 or receive circuitry 106. Such control can be based on available modes of operation (e.g., velocity flow imaging, B-mode imaging, velocity flow imaging + B-mode imaging, etc.) of the console 100. In addition, such control can be based on one or more signals indicative of
5 input from a user, a default configuration, etc. A user interface (UI) 110 produces the one or more signals indicative of the input from a user. The UI 110 may include one or more input devices (e.g., a button, a knob, a slider, a touch pad, etc.) and/or one or more output devices (e.g., a display screen, lights, a speaker, etc.).

A beamformer(s) 112 processes the electrical signals and produces data used to
10 generate at least an image and a vector velocity estimate. For a B-mode image, the beamformer 112 processes the signals by applying time delays, weighting the channels, and summing the weighted delayed signal, and/or otherwise beamforming the signals. For transverse oscillation (TO) VFI, the beamformer 112 beamforms beams to produce spatial lateral in-phase (I) and quadrature (Q) components. For this, a transverse oscillation is
15 introduced in the ultrasound field, and this oscillation generates received signals that depend on the transverse oscillation. The basic idea is to create a double-oscillating pulse-echo field and use a particular apodization profile(s) in receive. Suitable apodization functions are discussed in Jensen et al., "A New Method for Estimation of Velocity Vectors," IEEE Trans. Ultrason., Ferroelec., Freq. Contr., vol. 45, pp. 837–851, 1998, and
20 Udesen et al., "Investigation of Transverse Oscillation Method," IEEE Trans. Ultrason., Ferroelec., Freq. Contr., vol. 53, pp. 959–971, 2006. The beamformer(s) 112 can process the electrical signals to produce data for other vector flow approaches.

Returning to Figure 1, an image processor 114 processes the beamformed data and generates a sequence of focused, coherent echo samples along focused scanlines of a
25 scanplane, or a B-mode image. The image processor 114 may also be configured to process the scanlines to lower speckle and/or improve specular reflector delineation via spatial compounding and/or perform other processing such as FIR filtering, IIR filtering, etc. The B-mode image can be displayed, e.g., in a graphical user interface (GUI), which allows a user to selectively rotate, scale, manipulate, take measurements on, etc. the
30 displayed data. This can be through a mouse, a keyboard, a touch-screen and/or the like.

A vector flow imaging (VFI) processor 116 also processes the beamformed data. In one instance, this includes processing the beamformed data using a TO approach and

determining from the processed data one or more velocity components such as an axial/depth velocity component, a lateral velocity component, and/or an elevation velocity component. Examples of suitable velocity processing are described in patent US 6,148,224 A, titled "Apparatus and method for determining movements and velocities of moving objects," and filed December 30, 1998, patent US 6,859,659 A, titled "Estimation of vector velocity," and filed May 10, 2000, the entirety of which is incorporated herein by reference, and patent application US 2014/0257103 A1, titled "Three Dimensional (3D) Transverse Oscillation Vector Velocity Ultrasound Imaging," and filed October 11, 2011, the entirety of which is incorporated herein by reference.

10 A visualization processor 118 receives both the images and the vector velocity estimates, processes this data via a visualization algorithm(s) 120 to create a visualization of flow magnitude and direction, and visually presents the visualization via a display 122. As described in greater detail below, the visualization processor 118, in one instance, superimposes or overlays graphical indicia indicative of static and/or dynamic flow over a
15 B-mode image. This visualization can provide a global view of the flow throughout the entire image and/or a local view of the flow at particular points in the image. In one example, graphical indicia for flow measurements can show global flow characteristics such as vortices, flow reversal, flow direction changes across an entire predetermined portion of a vessel of interest. In one instance, this provides an intuitive and informative
20 visualization for clinicians. Furthermore, this approach can be used for real-time (i.e., during scanning as ultrasound signals are transmitted and echoes are received and processed) visualizations and/or off-line data ultrasound visualizations, including 2-D, 3-D, 4-D and/or other flow visualization.

It is to be appreciated that one or more of the velocity processor 116 and the
25 visualization processor 120 can be implemented by a processor (e.g., a central processing unit, a microprocessor, etc.) executing a computer readable instruction embedded or stored on non-transitory computer readable medium (which excludes transitory computer readable medium) such as physical memory and/or carried by transitory computer readable medium such as a carrier wave, signal, etc. Additionally or alternatively, the velocity
30 processor 116 and the visualization processor 120 can be implemented by a processor are implemented by the processor executing instructions carried by transitory computer

readable medium (which excludes non-transitory computer readable medium) such as a carrier wave, a signal, etc.

Furthermore, the console 100 can be part of a portable system on a stand with wheels, a system residing on a tabletop, and/or other system in which the transducer array 102 is housed and physically supported in a probe or the like and the console 100 is part of an apparatus separate therefrom. In this instance, the transducer array 102 and the console 100 transfer information there between via a wired and/or wireless connection / communication channel via complementary communication interfaces. In another instance, the transducer array 102 and the console 100 are housed and physically supported in a same apparatus such as within a single enclosure hand-held ultrasound scanning device.

Examples of suitable visualization algorithm(s) 120 include, but are not limited to, a massless particle motion simulation (MPMS) algorithm, a direct image synthesis (DIS) algorithm, a flow trace visualization (FTV) algorithm, a combination thereof, and/or other visualization algorithm. Examples of these algorithms are described next.

With the MPMS algorithm, the visualization processor 120 injects virtual particles into the flow pattern. The particles propagate based on the underlying flow vector data for better visualization of the motion. The method allows the user to virtually see the blood as it flows through the vessel. The seeding of the particles for injecting new particles can be random and/or based on a uniform distribution. Random seeding may provide a more realistic visualization of the flow. Different particles can be used for this purpose. Particles can be simple geometric shapes such as squares, circles, points, etc., other geometric shapes such as arrows, lines, cones, pictographs, virtual blood cells, glyphs, etc., and/or other graphical indicia. These particles can also have a life span, dying out after a set number of frames, seconds or steps.

With the MPMS algorithm, the visualization processor 120 can control (e.g., set and/or change) the flow visualization speed, including scaling (e.g., slowing down and/or speeding up) the flow. In one instance, this adjusts the speed so that the user can visually perceive the flow, e.g., for flow that would otherwise be too fast for the user to visually perceive. In one example, this scaling factor can be a ratio between display rate (~30-60Hz) in real-time and the actual acquisition rate (in the kHz range). This allows the user to visualize the flow in slow motion where the particles may be moving too fast to be

recognizable in the display. This can be done in real-time without slowing down the speed of imaging (e.g., decreasing the frame rate). This represents an improvement in the technology.

5 With the MPMS algorithm, the visualization processor 120 can additionally or alternatively perform one or more of the following variations and/or other variations. The visualization processor 120 can adjust color, transparency, orientation, etc. of particles based on flow magnitude, flow direction, flow variance, flow vorticity, flow turbulence, etc. An example of this is colorized ellipses oriented in the flow direction, with the lengths of the major and minor axes adjusted based on the flow variance. The
10 visualization processor 120 can combine/fuse this approach with other visualization methods such as conventional 1-D method, static arrows, etc. The visualization processor 120 can enhance the data via lighting effects, such as specular and diffuse reflections. Again, the visualization approach can be employed with 2-D, 3-D, 4-D and/or other flow visualization.

15 Figures 2-4 visualization examples using the MPMS algorithm.

Figure 2 show a B-mode image with a vessel 202, including a vessel wall 204 and a lumen 206. Figure 3 shows an MPMS visualization 302 for flow within in the lumen 206 for an entire predetermined region 304, using gray scale to represent flow magnitude and arrows to represent global flow. Figure 4 shows the B-mode image with the MPMS
20 visualization 302 superimposed over the vessel 202.

With the DIS algorithm, the visualization processor 120 warps or distorts a certain image in the direction of the flow. This has the effect of blowing or smearing the input image in the direction of the flow. It can be done statically (considering only the current frame) for an instantaneous view of the flow or dynamically (considering the flow over
25 multiple previous frames) for time varying flow showing the direction of flow over time. An example DIS algorithm is the line integral convolution (LIC) algorithm. This algorithm utilizes a noise texture as the input image and distorts it based on the flow. Both white noise and sparse noise can be used as the input image. The method can also be extended by using other types of input images.

30 With the DIS algorithm, the visualization processor 118 can additionally or alternatively perform one or more of the following variations and/or other variations. The visualization processor 120 can control the flow visualization speed, as described with the

MPMS algorithm. The visualization processor 120 can apply color coding, transparency, etc. to images based on flow magnitude, flow direction, flow variance, flow vorticity, flow turbulence, etc. The visualization processor 120 can combine/fuse this approach with other visualization methods such as conventional 1-D method, static arrows, etc. The
5 visualization processor 120 can enhance the data via lighting effects, such as specular and diffuse reflections. Again, the visualization approach can be employed with 2-D, 3-D, 4-D and/or other flow visualization.

Figures 8-10, 11-13, 14-16 and 17-19 show visualization examples using the DIS algorithm.

10 Figure 8 show the B-mode image of Figure 2. Figure 9 shows a DIS visualization 902 for flow within in the lumen 206 for an entire predetermined region 904, using gray scale to represent flow magnitude and streamlines, created via LIC with white noise, to represent global flow. Figure 10 shows the B-mode image with the DIS visualization 902 superimposed over the vessel 202. Figure 11 show the B-mode image of Figure 2. Figure
15 12 shows a DIS visualization 1202 for flow within in the lumen 206 for an entire predetermined region 1204, using gray scale to represent flow magnitude and streamlines, created via LIC with sparse noise, to represent global flow. Figure 10 shows the B-mode image with the DIS visualization 1202 superimposed over the vessel 202.

Figure 14 shows the B-mode image of Figure 2. Figure 15 shows a DIS
20 visualization 1502 for flow within in the lumen 206 for an entire predetermined region 1504, using gray scale to represent flow magnitude and streaklines, created via time varying LIC with white noise, to represent global flow. Figure 16 shows the B-mode image with the DIS visualization 1502 superimposed over the vessel 202. Figure 17 show the B-mode image of Figure 2. Figure 18 shows a DIS visualization 1802 for flow within
25 in the lumen 206 for an entire predetermined region 1804, using gray scale to represent flow magnitude and streaklines, created via time varying LIC with sparse noise, to represent global flow. Figure 19 shows the B-mode image with the DIS visualization 1802 superimposed over the vessel 202.

With the FTV algorithm, the visualization processor 120 seeds lines in the flow
30 direction to generate their trace. These lines follow the pattern of the flow. These lines can have a life span, die out and be reseeded after a set number of frames, seconds or steps. This allows the flow to be visualized by tracing its path. Seeding of the traces can

be done on a fixed grid or a random grid. With the FTV algorithm, the visualization processor 120 can additionally or alternatively perform one or more of the below variations and/or other variations.

5 With the FTV algorithm, the visualization processor 120 can apply color coding, transparency, etc. to images and widths of lines based on flow magnitude, flow direction, flow variance, etc. The visualization processor 120 can combine this approach with other visualization methods such as flow trace + conventional 1D method + arrows, etc. The visualization processor 120 can enhance the data via lighting effects, such as specular and diffuse reflections. Again, the visualization approach can be employed with 2-D, 3-D, 4-D
10 and/or other flow visualization. This can be with either lines in 3-D or 2-D dimensional ribbons rendered in 3-D. When using ribbons, ribbons can also be twisted based on flow turbulence or vorticity.

Figures 20-22 show visualization examples using the FTV algorithm. Figure 20 show the B-mode image of Figure 2. Figure 21 shows a FTV visualization 2102 for flow
15 within in the lumen 206, using gray scale to represent flow magnitude and lines to represent flow direction. Figure 22 shows the B-mode image with the FTV visualization 2102 superimposed over the vessel 202.

In one instance, the flow is updated via an estimate of the new position. This can be done in a linear manner or using higher order estimate i.e. RungeKutta, etc. In one
20 instance, an effect of higher order integration is a more accurate flow path. This estimation would be used in all the visualization methods if it was implemented i.e. MPMS, DIS and/or FTV.

For comparison, Figures 5, 6A, 6B and 7 show a prior art visualization combining a magnitude color map and arrows for local point based flow. Figure 5 shows the B-mode
25 image of Figure 2. Figure 6A shows a flow magnitude color map 602 in the lumen 206 for certain points. Figure 6B shows flow direction arrows 604 for the lumen 206. Figure 7 shows the B-mode image of Figure 5 with the magnitude color map 602 and the local flow direction arrows 604 superimposed over the vessel 202.

Figure 23 illustrates a method for visualization flow magnitude and global flow
30 direction determined based on VFI data with a B-mode image.

It is to be understood that the following acts are provided for explanatory purposes and are not limiting. As such, one or more of the acts may be omitted, one or more acts

may be added, one or more acts may occur in a different order (including simultaneously with another act), etc.

At 2302, an ultrasound signal is transmitted into a field of view.

At 2304, echoes, in response to the ultrasound signal, are received by a transducer
5 array.

At 2306, the echoes are beamformed.

At 2308, a B-mode image is generated with the beamformed echoes.

At 2310, flow direction and magnitude are determined via VFI with the
beamformed echoes, as described herein and/or otherwise.

10 At 2312, visualizations of the global flow direction and flow magnitude are
determined, as described herein and/or otherwise.

At 2314, the B-mode image is visually displayed with a visualization of the global
flow and flow magnitude superimposed thereover.

The methods described herein may be implemented via one or more
15 processors executing one or more computer readable instructions encoded or embodied on
computer readable storage medium such as physical memory which causes the one or
more processors to carry out the various acts and/or other functions and/or acts.
Additionally or alternatively, the one or more processors can execute instructions carried
by transitory medium such as a signal or carrier wave.

20 The application has been described with reference to various embodiments.
Modifications and alterations will occur to others upon reading the application. It is
intended that the invention be construed as including all such modifications and
alterations, including insofar as they come within the scope of the appended claims and the
equivalents thereof.

25

CLAIMS

What is claimed is:

1. A method of ultrasound imaging, comprising:
5 transmitting an ultrasound signal with an ultrasound transducer array;
receiving from the ultrasound transducer array electrical signals indicative of
ultrasound echoes received by the ultrasound transducer array;
beamforming the electrical signals, which generates beamformed data;
processing the beamformed data, which generates an image, wherein the image
10 represents at least an anatomical vessel of interest;
processing the beamformed data, which generates flow direction data and flow
magnitude data for blood cells flowing in a predetermined region of the anatomical vessel;
processing the flow direction data and the flow magnitude data, which creates a
visualization of the flow magnitude data and the flow direction data for the entire
15 predetermined region of the vessel; and
visually presenting the image with the visualization superimposed thereover.
2. The method of claim 1, wherein the processing of the flow direction data and the
flow magnitude data includes using a massless particle motion simulation algorithm in
20 which graphical indicia is injected into the predetermined region of the vessel and
propagates within the predetermined region of the vessel based on the flow direction data.
3. The method of claim 2, further comprising
seeding the graphical indicia with one of a random distribution or a uniform
25 distribution.
4. The method of any of claims 2 to 3, wherein graphical indicia are removed from
the display after at least one of a predetermined time from injection or a predetermined
number of frames from injection.
30
5. The method of any of claims 2 to 4, further comprising:

controlling a flow speed of the graphical indicia independent of a frame rate as the electrical signals are generated and received.

6. The method of claim 1, wherein the processing of the flow direction data and the flow magnitude data includes using a direct image synthesis algorithm, which warps the predetermined region of the vessel in a direction of the flow.
7. The method of claim 6, further comprising:
warping only a current frame, providing an instantaneous view of the flow.
8. The method of claim 6, further comprising:
warping multiple frames, providing a time varying flow showing the direction of flow over time.
9. The method of any of claims 6 to 8, wherein the flow direction data and the flow magnitude data is processed using a line integral convolution algorithm.
10. The method of claim 9, wherein the line integral convolution algorithm warps one of a white noise input image or a sparse noise input image.
11. The method of claim 1, wherein the processing of the flow direction data and the flow magnitude data includes using a flow trace visualization algorithm, which seeds lines in a flow direction to generate their trace.
12. The method of claim 11, further comprising:
controlling a flow speed of the lines independent of a frame rate as the electrical signals are generated and received.
13. The method of any of claims 11 to 12, further comprising
seeding the lines based on a random or fixed grid.

14. The method of any of claims 11 to 13, wherein a line is removed from the display after at least one of a predetermined time of creation or a predetermined number of frames from creation.
- 5 15. A computer readable medium embedded with computer executable instructions, which, when executed by a processor of a computer, causes the processor to:
- receive, from an ultrasound transducer array, electrical signals indicative of ultrasound echoes received by the ultrasound transducer array;
 - generate beamformed data by beamforming the electrical signals;
 - 10 generate an image by processing the beamformed data;
 - generate vector flow imaging data by processing the beamformed data, wherein the vector flow imaging data includes a flow direction data and a flow magnitude data for blood cells flowing in a predetermined region of an anatomical vessel;
 - create a visualization of the flow direction data and the flow magnitude data for the
 - 15 entire predetermined region of the vessel with the vector flow imaging data; and
 - display the image with the visualization overlaid thereover.
16. The computer readable medium of claim 15, wherein the processor create the visualization based on one or more of a massless particle motion simulation algorithm, a
- 20 direct image synthesis algorithm, and a flow trace visualization algorithm.
17. The computer readable medium of any of claims 15 to 16, wherein the visualization includes at least one of color coding and transparency based on flow magnitude, direction, variance, vorticity, and turbulence.
- 25 18. The computer readable medium of any of claims 15 to 17, wherein the visualization includes a lighting effect, including at least one of specular reflection and diffuse reflection.
- 30 19. The computer readable medium of any of claims 15 to 18, wherein the visualization is one of a 2-D, a 3-D, or a 4-D flow visualization.

20. The computer readable medium of any of claims 15 to 19, wherein the visualization shows a flow variance.
21. The computer readable medium of any of claims 15 to 20, wherein the visualization shows a flow vorticity.
22. The computer readable medium of any of claims 15 to 21, wherein the visualization shows a flow turbulence.
23. The computer readable medium of any of claims 20 to 21, wherein the visualization includes ribbons that are twisted based on the flow turbulence or the flow vorticity.
24. An ultrasound imaging console, comprising:
receive circuitry (106) configured to receive, from an ultrasound transducer array (102), electrical signals indicative of ultrasound echoes received by the ultrasound transducer array;
a beamformer (112) configured to beamform the electrical signals;
an image processor (114) configured to generate an image by processing the beamformed electrical signals;
a vector flow imaging processor (116) configured to determine a flow direction and a flow magnitude by processing the beamformed electrical signals using a vector flow imaging algorithm;
a visualization processor (118) configured to generate a visualization of the determined flow direction and of the flow magnitude; and
a display (124) configured to display the generated image with the generated visualization of the determined flow direction and of the flow magnitude superimposed over the displayed image.
25. The console of claim 24, wherein the vector flow imaging processor uses a transverse oscillation approach to determine the flow direction and magnitude.

26. The console of any of claims 24 to 25, wherein the visualization algorithm is a massless particle motion simulation algorithm.

27. The console of any of claims 24 to 25, wherein the visualization algorithm is a
5 flow trace visualization algorithm.

28. The console of any of claims 24 to 25, wherein the visualization algorithm is a direct image synthesis algorithm.

10

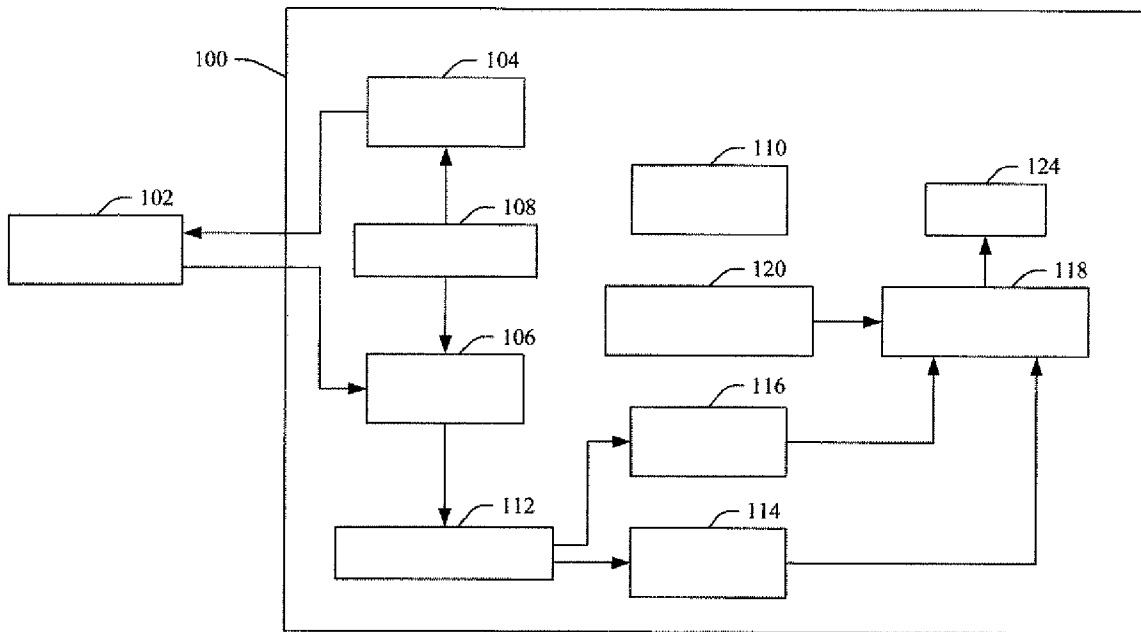

FIGURE 1

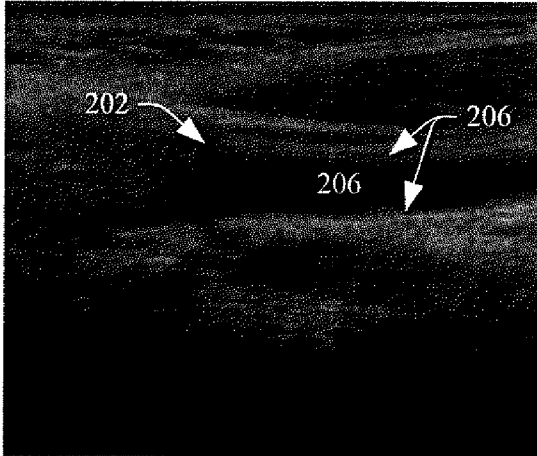

FIGURE 2

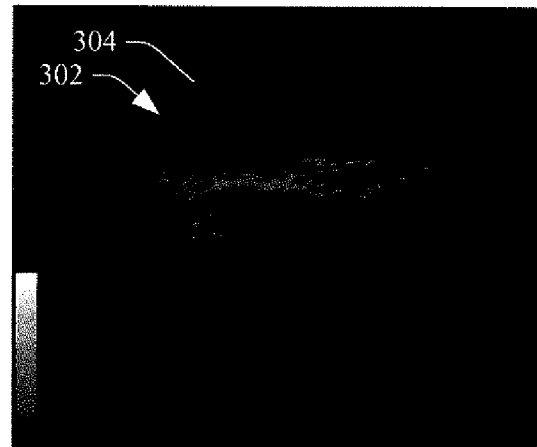

FIGURE 3

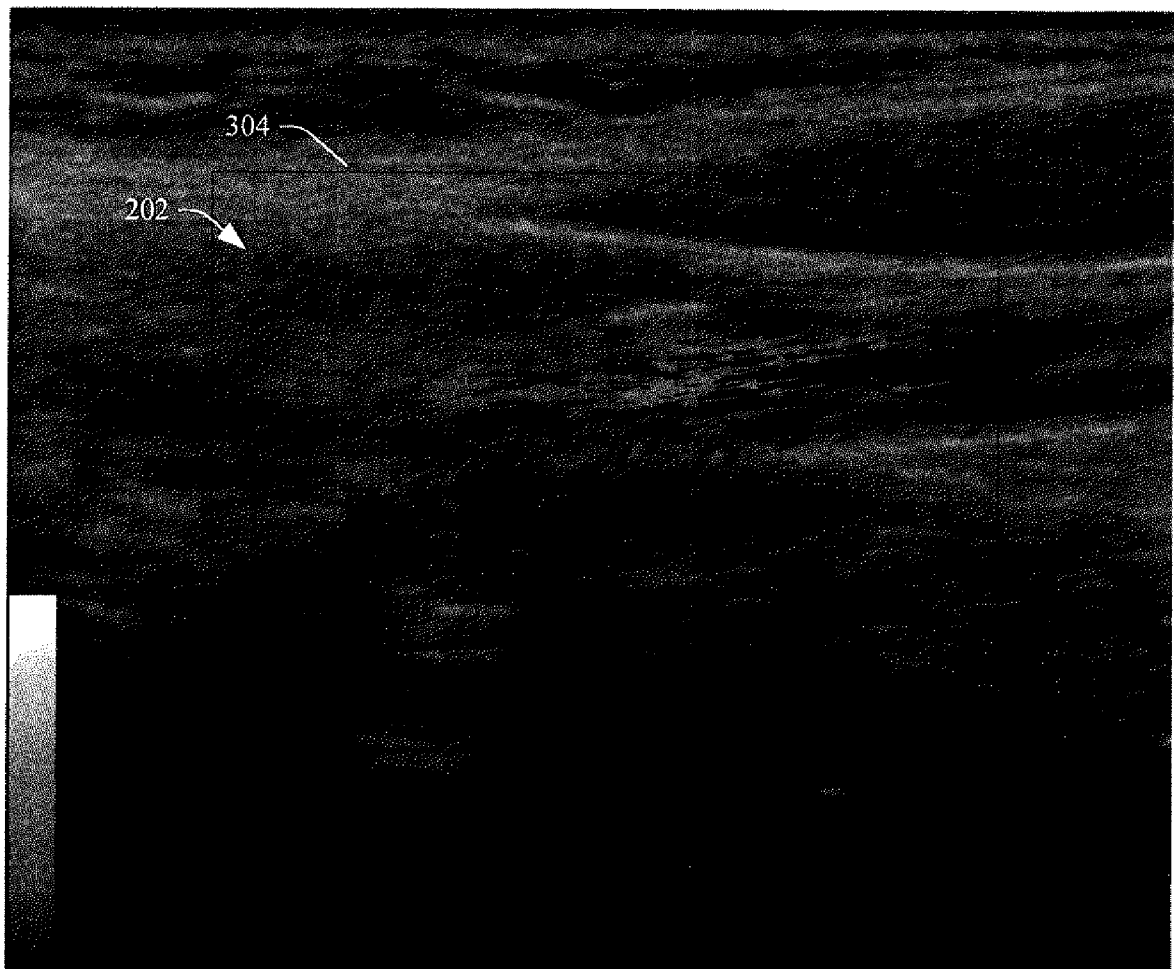

FIGURE 4

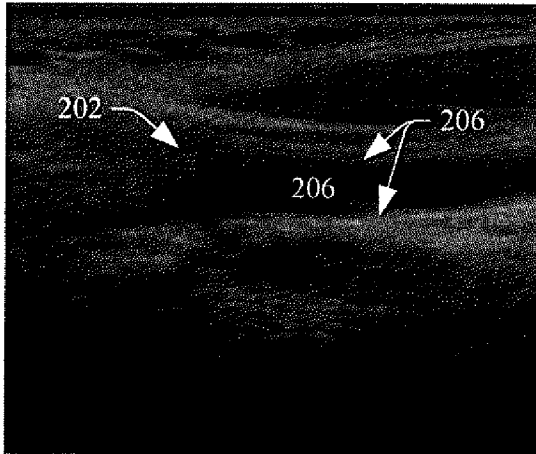

FIGURE 5

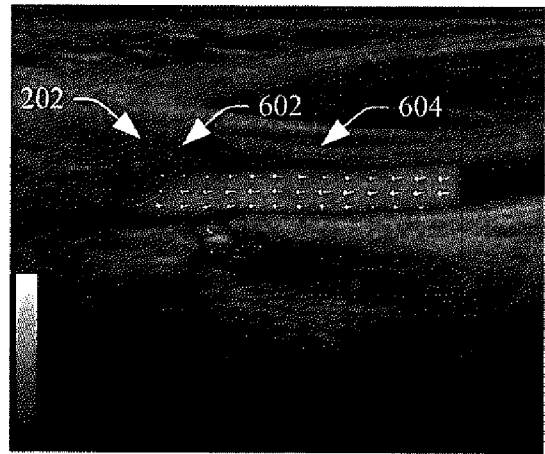

FIGURE 7
(PRIOR ART)

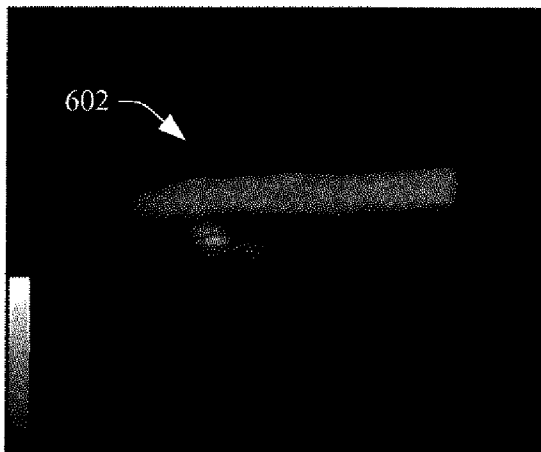

FIGURE 6A

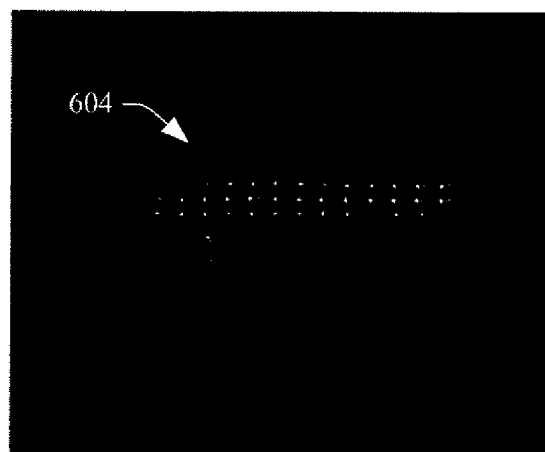

FIGURE 6B

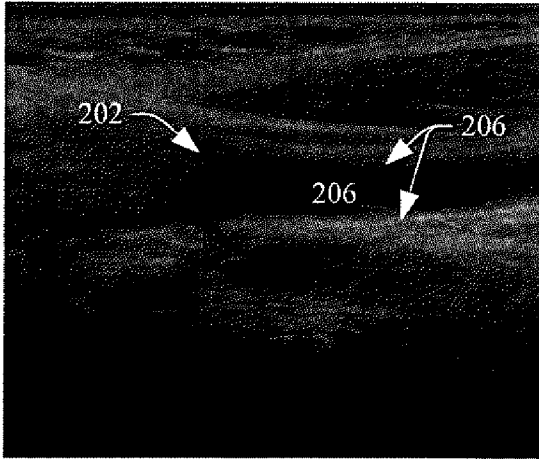

FIGURE 8

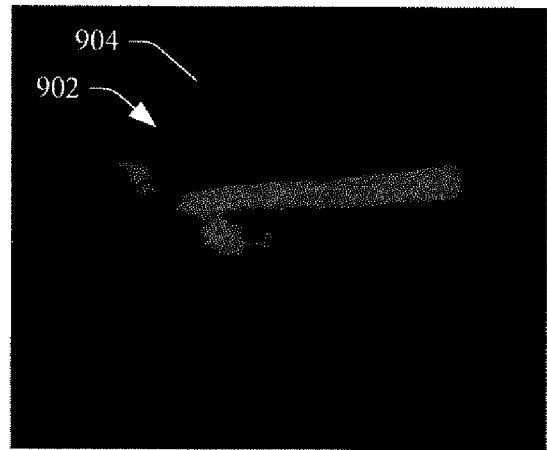

FIGURE 9



FIGURE 10

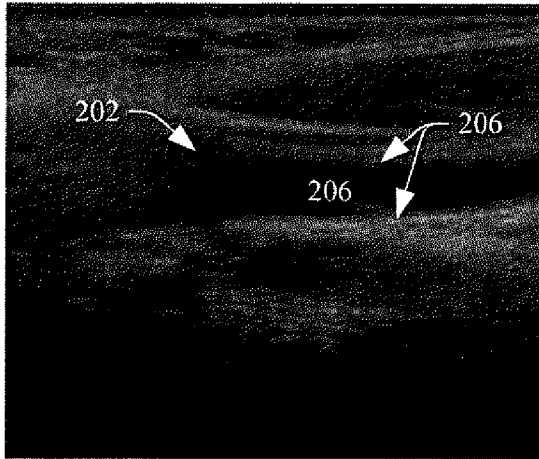

FIGURE 11

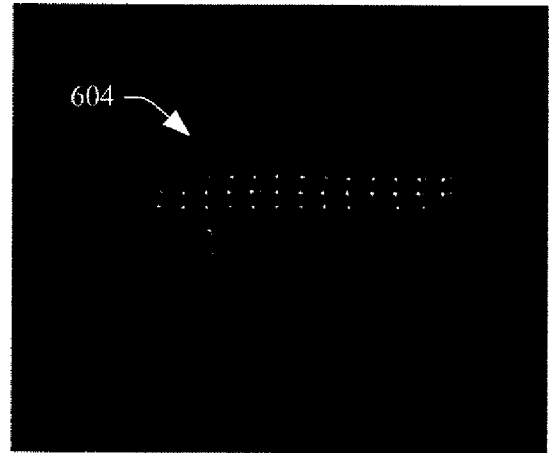

FIGURE 12

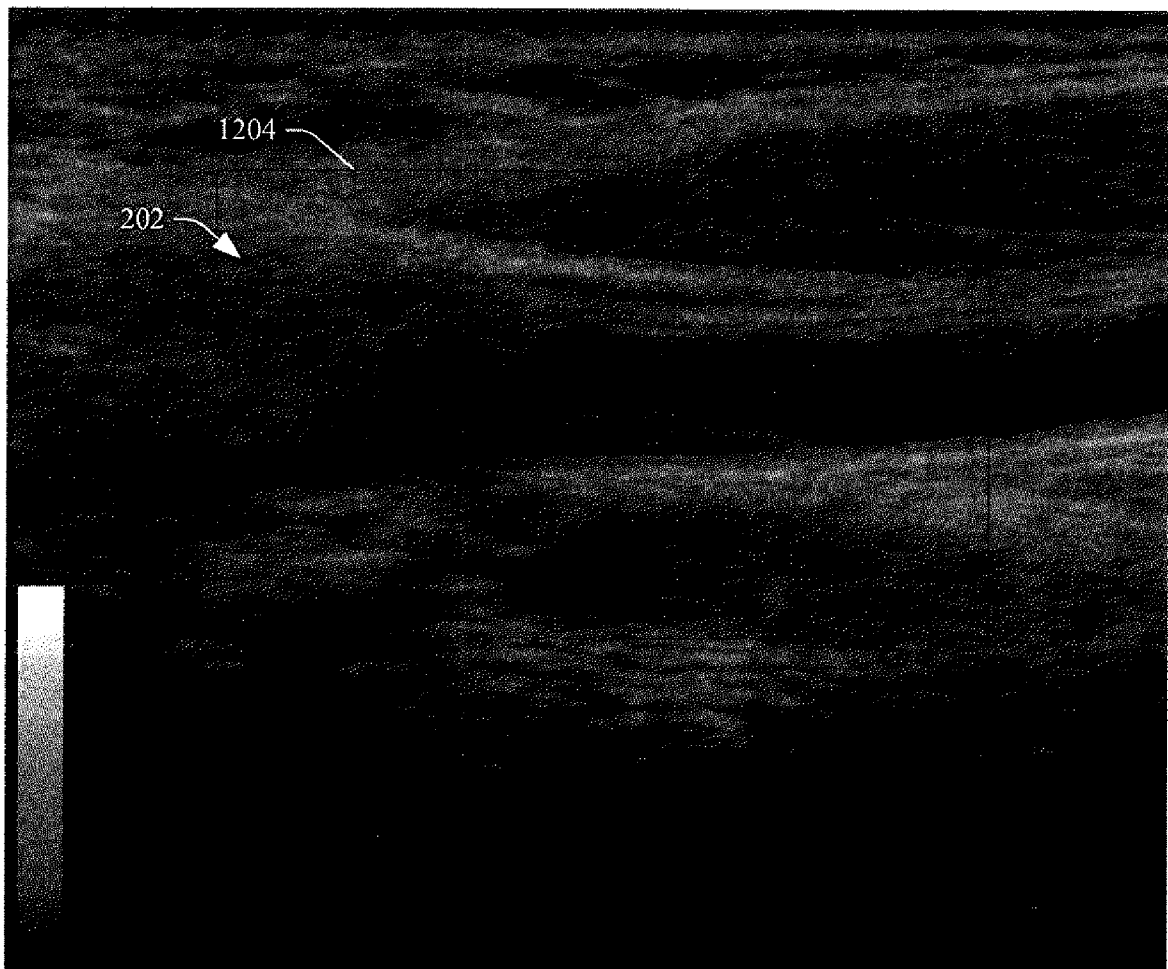

FIGURE 13

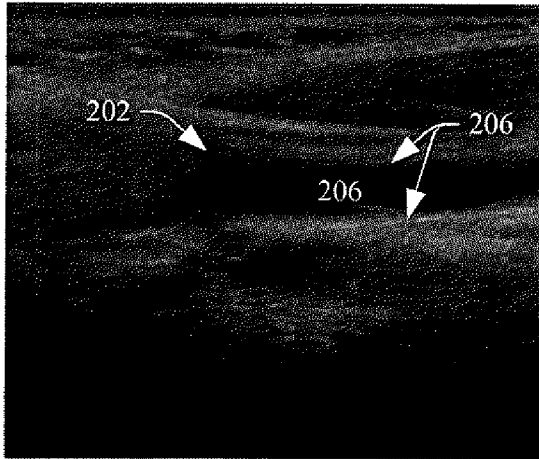

FIGURE 14

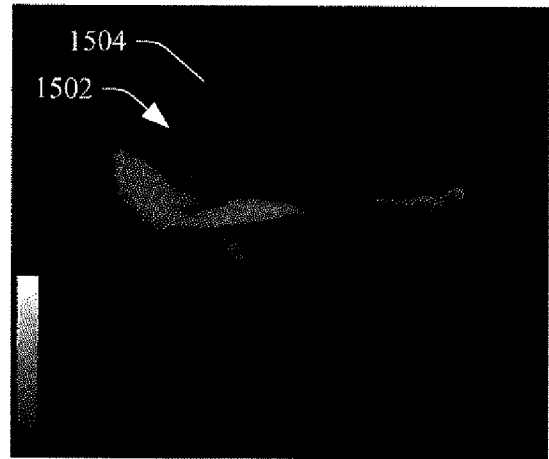

FIGURE 15

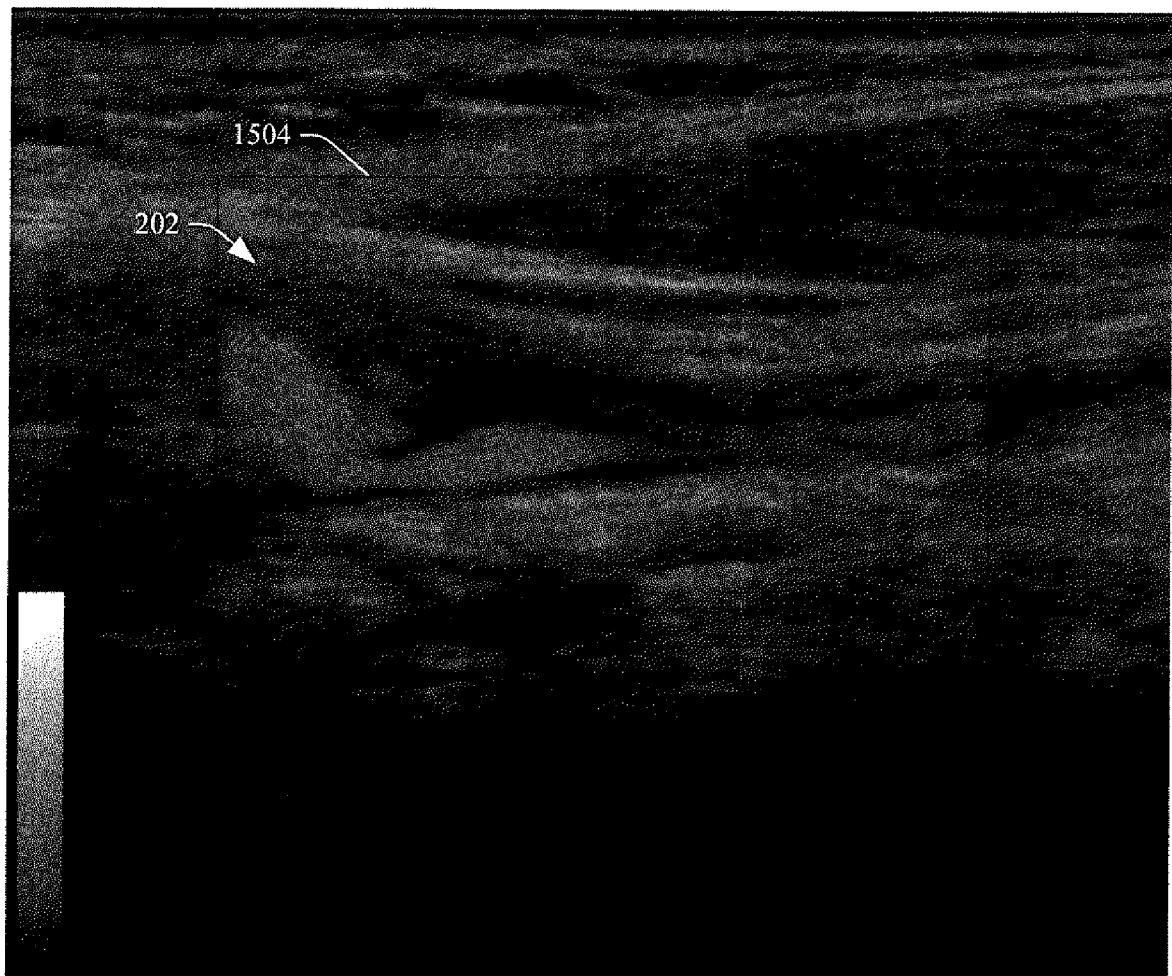

FIGURE 16

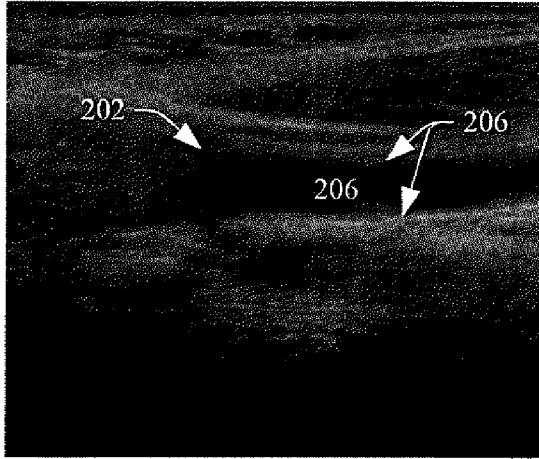

FIGURE 17

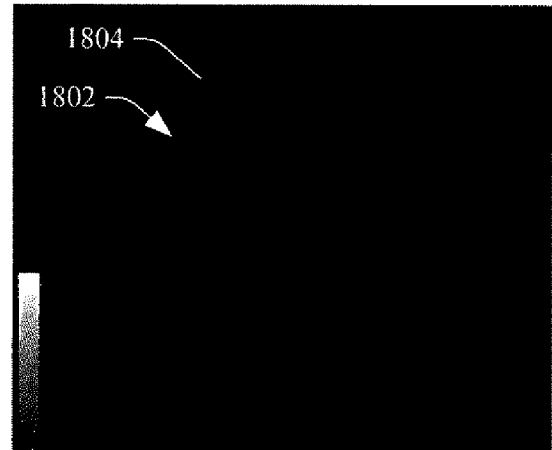

FIGURE 18

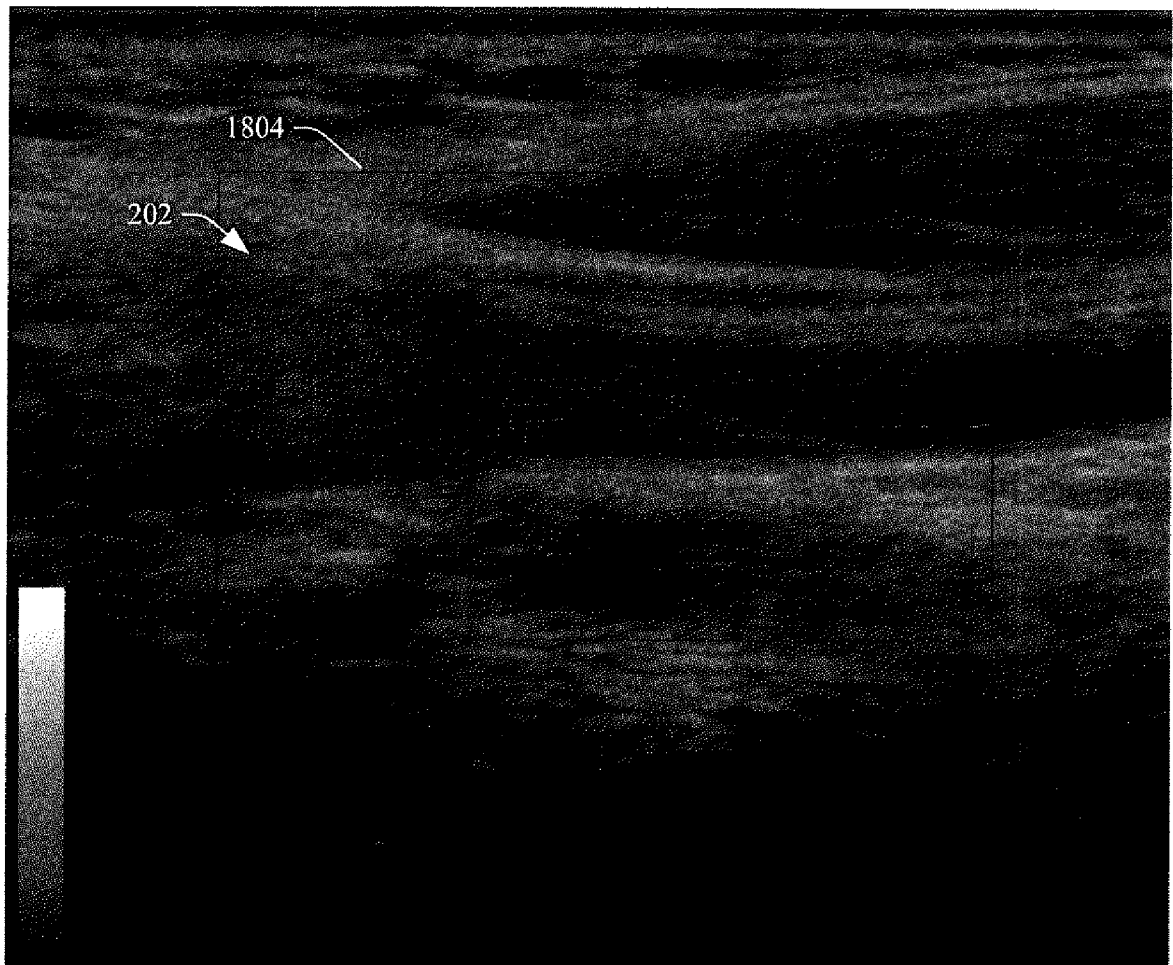

FIGURE 19

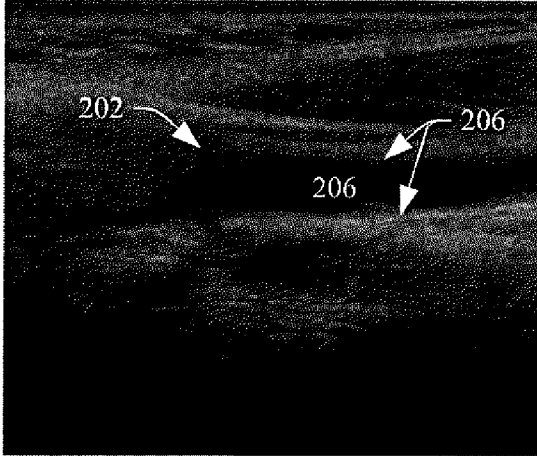

FIGURE 20

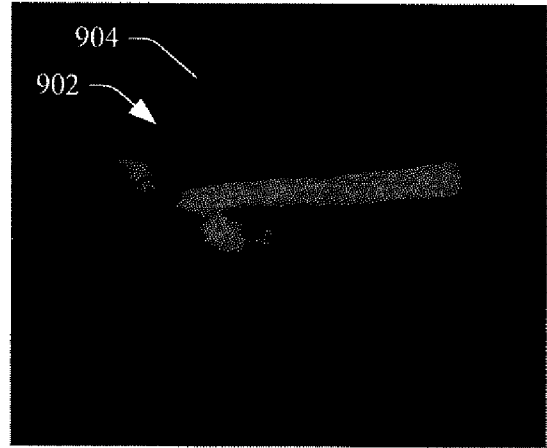

FIGURE 21

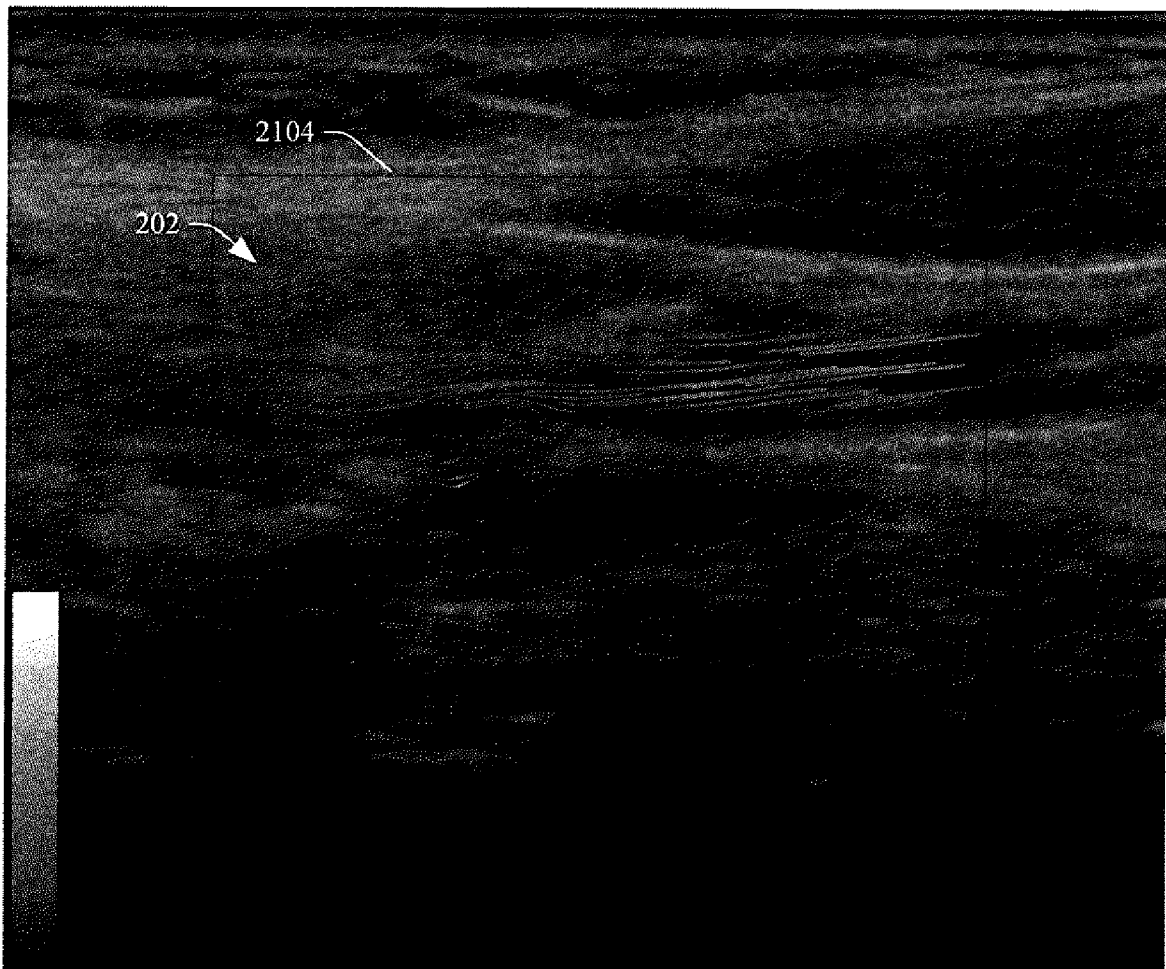

FIGURE 22

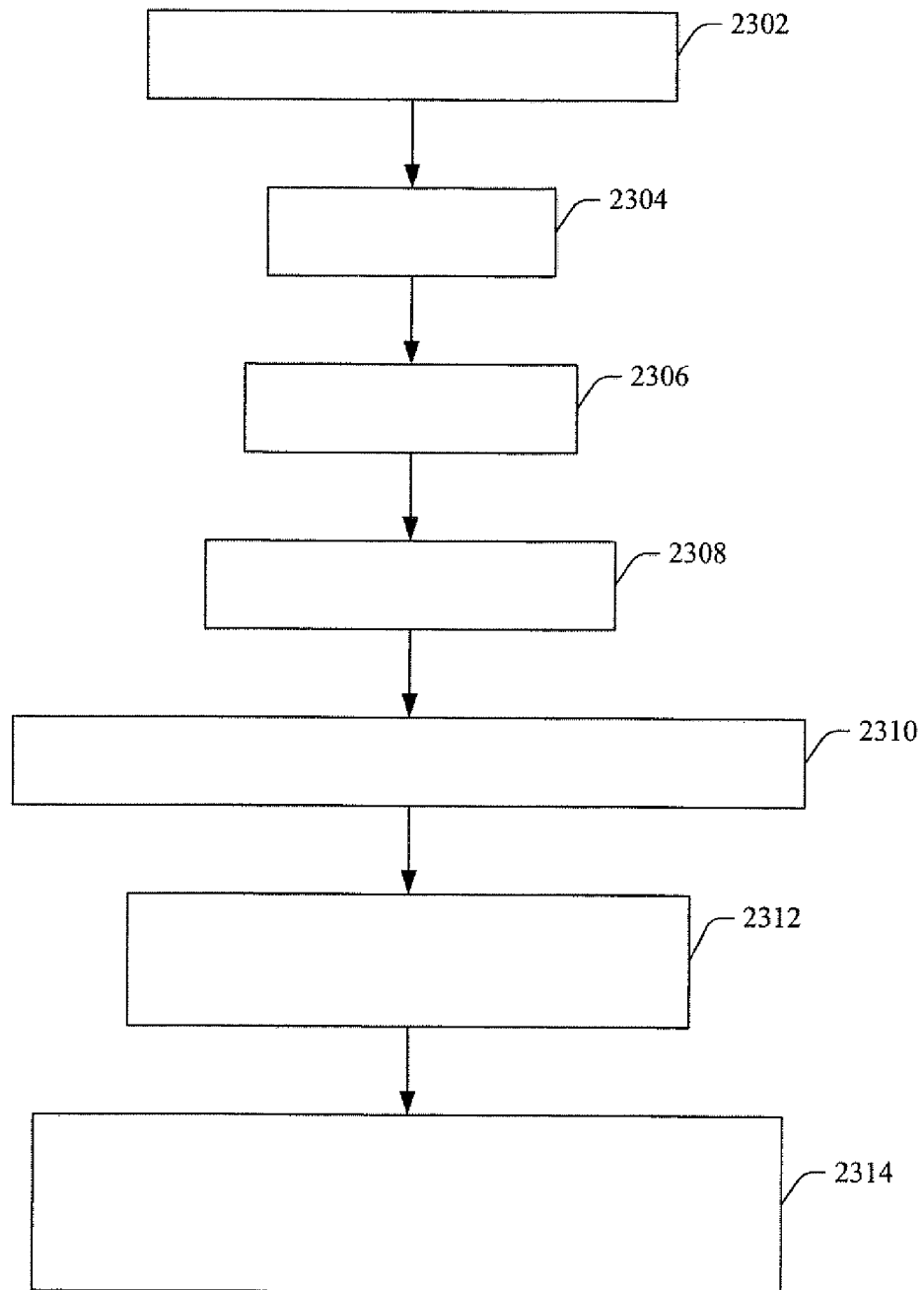

FIGURE 23

INTERNATIONAL SEARCH REPORT

International application No.
PCT/IB2016/051579A. CLASSIFICATION OF SUBJECT MATTER
IPC: *A61B 8/14* (2006.01), *A61B 5/026* (2006.01), *G01S 15/89* (2006.01)

According to International Patent Classification (IPC) or to both national classification and IPC

B. FIELDS SEARCHED

Minimum documentation searched (classification system followed by classification symbols)
IPC (2006): A61B

Documentation searched other than minimum documentation to the extent that such documents are included in the fields searched

Electronic database(s) consulted during the international search (name of database(s) and, where practicable, search terms used)

Database: Canadian Patent Database (Intellect), Questel Orbit, USPTO West, IEEE Xplore

Keywords: ultrasound, image, vector, transducer array, vascular, vessel, beamform, flow, superimpose, random, indicia, distribute, frame, integral, convolution, distort, warp, seed, grid, trace

C. DOCUMENTS CONSIDERED TO BE RELEVANT

Category*	Citation of document, with indication, where appropriate, of the relevant passages	Relevant to claim No.
X --- Y	US 2013/0261456 (HAUGAARD et al.) 03 October 2013 (03-10-2013) * Paragraphs [0010], [0027], [0030], [0031], [0034]-[0042] and [0052] *	1, 2, 15, 17 and 24-26 --- 3-14, 16, 18-23, 27 and 28
Y	US 2015/0045666 (LIN) 12 February 2015 (12-02-2015) * Paragraphs [0008], [0011], [0012], [0015], [0029], [0030], [0049], [0050], [0067], [0071] and [0086] *	3-5, 20 and 22
Y	Shen et al., A New Line Integral Convolution Algorithm for Visualizing Time-Varying Flow Fields, IEEE Transactions on Visualization and Computer Graphics, vol. 4, no. 2, April-June 1998, pages 98-108. * Abstract; pages 98-100, Section 1: Introduction, Section 2: Background and Related Work *	6-10, 16 and 28
Y	van Pelt et al., Exploration of 4D MRI Blood-Flow Using Stylistic Visualization, IEEE Transaction on Visualization and Computer Graphics, vol. 16, no. 6, November/December 2010, pages 1339-1347. * Page 1339, right column, 3rd paragraph; pages 1342-1344, Section 4.2.2: Line primitives *	11-14, 16, 19 and 27

 Further documents are listed in the continuation of Box C. See patent family annex.

* "A" "E" "L" "O" "P"	Special categories of cited documents: document defining the general state of the art which is not considered to be of particular relevance earlier application or patent but published on or after the international filing date document which may throw doubts on priority claim(s) or which is cited to establish the publication date of another citation or other special reason (as specified) document referring to an oral disclosure, use, exhibition or other means document published prior to the international filing date but later than the priority date claimed	"I" "X" "Y" "&"	later document published after the international filing date or priority date and not in conflict with the application but cited to understand the principle or theory underlying the invention document of particular relevance; the claimed invention cannot be considered novel or cannot be considered to involve an inventive step when the document is taken alone document of particular relevance; the claimed invention cannot be considered to involve an inventive step when the document is combined with one or more other such documents, such combination being obvious to a person skilled in the art document member of the same patent family
--------------------------------------	--	--------------------------	--

Date of the actual completion of the international search
25 November 2016 (25-11-2016)Date of mailing of the international search report
02 December 2016 (02-12-2016)Name and mailing address of the ISA/CA
Canadian Intellectual Property Office
Place du Portage 1, C114 - 1st Floor, Box PCT
50 Victoria Street
Gatineau, Quebec K1A 0C9
Facsimile No.: 819-953-2476

Authorized officer

Alan Chan (819) 639-2473

INTERNATIONAL SEARCH REPORT

International application No.

PCT/IB2016/051579

C (Continuation). DOCUMENTS CONSIDERED TO BE RELEVANT		
Category*	Citation of document, with indication, where appropriate, of the relevant passages	Relevant to claim No.
Y	US 2013/0289408 (TANAKA et al.) 31 October 2013 (31-10-2013) * Paragraphs [0065] and [0119] *	18, 21 and 23
A	US 2016/0015366 (HAUGAARD et al.) 21 January 2016 (21-01-2016)	1-28
A	US 2014/0073923 (HAUGARRD et al.) 13 March 2014	1-28
A	EP0947853A2 (CHIAO et al.) 6 October 1999 (06-10-1999)	1-28
A	US 2016/0038124 (TSUJITA) 11 February 2016 (11-02-2016)	1-28
A	US 2014/0236008 (TANAKA et al.) 21 August 2014 (21-08-2014)	1-28
A	US 2008/0077010 (COHEN-SOLAL et al.) 27 March 2008 (27-03-2008)	1-28
A	Cabral et al., Imaging Vector Fields Using Line Integral Convolution, SIGGRAPH '93 Proceedings of the 20 th Annual Conference on Computer Graphics and Interactive Techniques, August 2-6, 1993, pages 263-270	1-28
A	Kirbas et al., A Review of Vessel Extraction Techniques and Algorithms, ACM Computing Surveys, vol. 36, no. 2, June 2004, pages 81-121.	1-28
A	Brambilla et al., Illustrative Flow Visualization: State of the Art, Trends and Challenges, EuroGraphics 2012 State of the Art Reports, pages 74-94.	1-28

INTERNATIONAL SEARCH REPORT
Information on patent family members

International application No.
PCT/IB2016/051579

Patent Document Cited in Search Report	Publication Date	Patent Family Member(s)	Publication Date
US2013261456A1	03 October 2013 (03-10-2013)	US2013261456A1 US8911373B2	03 October 2013 (03-10-2013) 16 December 2014 (16-12-2014)
US2015045666A1	12 February 2015 (12-02-2015)	US2015045666A1 US9173640B2 CN104490422A	12 February 2015 (12-02-2015) 03 November 2015 (03-11-2015) 08 April 2015 (08-04-2015)
US2013289408A1	31 October 2013 (31-10-2013)	US2013289408A1 US9259205B2 CN103327904A CN103327904B JP5627706B2 WO2012073863A1	31 October 2013 (31-10-2013) 16 February 2016 (16-02-2016) 25 September 2013 (25-09-2013) 06 May 2015 (06-05-2015) 19 November 2014 (19-11-2014) 07 June 2012 (07-06-2012)
US2016015366A1	21 January 2016 (21-01-2016)	US2016015366A1 CN105120761A EP2967490A1 WO2014140657A1	21 January 2016 (21-01-2016) 02 December 2015 (02-12-2015) 20 January 2016 (20-01-2016) 18 September 2014 (18-09-2014)
US2014073923A1	13 March 2014 (13-03-2014)	US2014073923A1 US9170330B2 US2016007951A1	13 March 2014 (13-03-2014) 27 October 2015 (27-10-2015) 14 January 2016 (14-01-2016)
EP0947853A2	06 October 1999 (06-10-1999)	EP0947853A2 EP0947853A3 EP0947853B1 DE10119814A1 DE19913198A1 DE60026658D1 DE60026658T2 EP1046928A2 EP1046928A3 EP1046928B1 IL129153D0 IL129153A IL135658D0 JP2000333957A JP4547065B2 JPH11318902A JP4549457B2 JP2002000607A JP4746758B2 JP2000316860A JP4903928B2 US6074348A US6186949B1 US6210332B1 US6312384B1 US6406430B1	06 October 1999 (06-10-1999) 08 January 2003 (08-01-2003) 11 January 2006 (11-01-2006) 25 October 2001 (25-10-2001) 07 October 1999 (07-10-1999) 11 May 2006 (11-05-2006) 04 January 2007 (04-01-2007) 25 October 2000 (25-10-2000) 28 January 2004 (28-01-2004) 15 March 2006 (15-03-2006) 17 February 2000 (17-02-2000) 12 February 2003 (12-02-2003) 20 May 2001 (20-05-2001) 05 December 2000 (05-12-2000) 22 September 2010 (22-09-2010) 24 November 1999 (24-11-1999) 22 September 2010 (22-09-2010) 08 January 2002 (08-01-2002) 10 August 2011 (10-08-2011) 21 November 2000 (21-11-2000) 28 March 2012 (28-03-2012) 13 June 2000 (13-06-2000) 13 February 2001 (13-02-2001) 03 April 2001 (03-04-2001) 06 November 2001 (06-11-2001) 18 June 2002 (18-06-2002)
US2016038124A1	11 February 2016 (11-02-2016)	US2016038124A1 CN104812312A CN104812312B JPWO2014050601A1 WO2014050601A1 WO2014050601A9	11 February 2016 (11-02-2016) 29 July 2015 (29-07-2015) 16 November 2016 (16-11-2016) 22 August 2016 (22-08-2016) 03 April 2014 (03-04-2014) 12 February 2015 (12-02-2015)
US2014236008A1	21 August 2014 (21-08-2014)	US2014236008A1 CN103781425A CN103781425B EP2769677A1 EP2769677A4 JPWO2013057999A1 JP5736462B2 WO2013057999A1	21 August 2014 (21-08-2014) 07 May 2014 (07-05-2014) 20 January 2016 (20-01-2016) 27 August 2014 (27-08-2014) 05 August 2015 (05-08-2015) 02 April 2015 (02-04-2015) 17 June 2015 (17-06-2015) 25 April 2013 (25-04-2013)

Continued in Supplemental Box

INTERNATIONAL SEARCH REPORT

International application No.
PCT/IB2016/051579

Continuation of patent family members

US2008077010A1	27 March 2008 (27-03-2008)	US2008077010A1	27 March 2008 (27-03-2008)
		CN101031242A	05 September 2007 (05-09-2007)
		CN100581483C	20 January 2010 (20-01-2010)
		EP1796546A1	20 June 2007 (20-06-2007)
		JP2008514263A	08 May 2008 (08-05-2008)
		WO2006035380A1	06 April 2006 (06-04-2006)

专利名称(译)	超声矢量流成像 (VFI) 数据的可视化		
公开(公告)号	EP3432805A1	公开(公告)日	2019-01-30
申请号	EP2016895303	申请日	2016-03-21
[标]发明人	MILES BRANDON ZAHIRI REZA ESKANDARI HANI		
发明人	MILES, BRANDON ZAHIRI, REZA ESKANDARI, HANI		
IPC分类号	A61B8/14 A61B5/026 G01S15/89		
CPC分类号	A61B8/06 A61B8/0891 A61B8/5223 A61B8/5246 G01S15/8984 G16H50/30 A61B8/5207 A61B2562/0204 A61B2562/04 G06T3/0093 G06T7/20		
其他公开文献	EP3432805A4		
外部链接	Espacenet		

摘要(译)

超声成像的方法包括利用超声换能器阵列发射超声信号。该方法还包括从超声换能器阵列接收指示由超声换能器阵列接收的超声回波的电信号。该方法还包括对电信号进行波束形成，这导致波束形成的数据。该方法还包括处理生成图像的波束形成数据。该图像至少表示感兴趣的解剖血管。该方法还包括处理波束形成的数据，其生成在解剖学血管的预定区域中流动的血细胞的流动方向数据和流动幅度数据。该方法还包括处理流向数据和流量值数据，其产生流量方向数据的可视化和船舶的整个预定区域的流量值数据。该方法还包括在视觉上呈现图像，其中叠加在其上的可视化。