



- (51) **International Patent Classification:**  
A61B 8/08 (2006.01) A61B 8/14 (2006.01)  
A61B 8/00 (2006.01)
- (21) **International Application Number:**  
PCT/US2015/029229
- (22) **International Filing Date:**  
5 May 2015 (05.05.2015)
- (25) **Filing Language:** English
- (26) **Publication Language:** English
- (30) **Priority Data:**  
61/989,679 7 May 2014 (07.05.2014) US
- (71) **Applicant:** MUFFIN INCORPORATED [US/US]; 1400 Cumberland Avenue, West Lafayette, IN 47906 (US).
- (72) **Inventors:** FEARNOT, Neal, E.; 1311 E 500n, West Lafayette, IN 47906 (US). MCKINNIS, Peter, S.; 200 Cedar Hollow Court, West Lafayette, IN 47906 (US). HAWKINS, Kem; 4084 Gran Haven Drive, Bloomington, IN 47401 (US).
- (74) **Agents:** BROWN, Christopher A. et al.; Woodard, Emhardt, Moriarty, Mcnett & Henry LLP, 111 Monument Circle, Suite 3700, Indianapolis, IN 46204 (US).
- (81) **Designated States** (unless otherwise indicated, for every kind of national protection available): AE, AG, AL, AM, AO, AT, AU, AZ, BA, BB, BG, BH, BN, BR, BW, BY,

BZ, CA, CH, CL, CN, CO, CR, CU, CZ, DE, DK, DM, DO, DZ, EC, EE, EG, ES, FI, GB, GD, GE, GH, GM, GT, HN, HR, HU, ID, IL, IN, IR, IS, JP, KE, KG, KN, KP, KR, KZ, LA, LC, LK, LR, LS, LU, LY, MA, MD, ME, MG, MK, MN, MW, MX, MY, MZ, NA, NG, NI, NO, NZ, OM, PA, PE, PG, PH, PL, PT, QA, RO, RS, RU, RW, SA, SC, SD, SE, SG, SK, SL, SM, ST, SV, SY, TH, TJ, TM, TN, TR, TT, TZ, UA, UG, US, UZ, VC, VN, ZA, ZM, ZW.

(84) **Designated States** (unless otherwise indicated, for every kind of regional protection available): ARIPO (BW, GH, GM, KE, LR, LS, MW, MZ, NA, RW, SD, SL, ST, SZ, TZ, UG, ZM, ZW), Eurasian (AM, AZ, BY, KG, KZ, RU, TJ, TM), European (AL, AT, BE, BG, CH, CY, CZ, DE, DK, EE, ES, FI, FR, GB, GR, HR, HU, IE, IS, IT, LT, LU, LV, MC, MK, MT, NL, NO, PL, PT, RO, RS, SE, SI, SK, SM, TR), OAPI (BF, BJ, CF, CG, CI, CM, GA, GN, GQ, GW, KM, ML, MR, NE, SN, TD, TG).

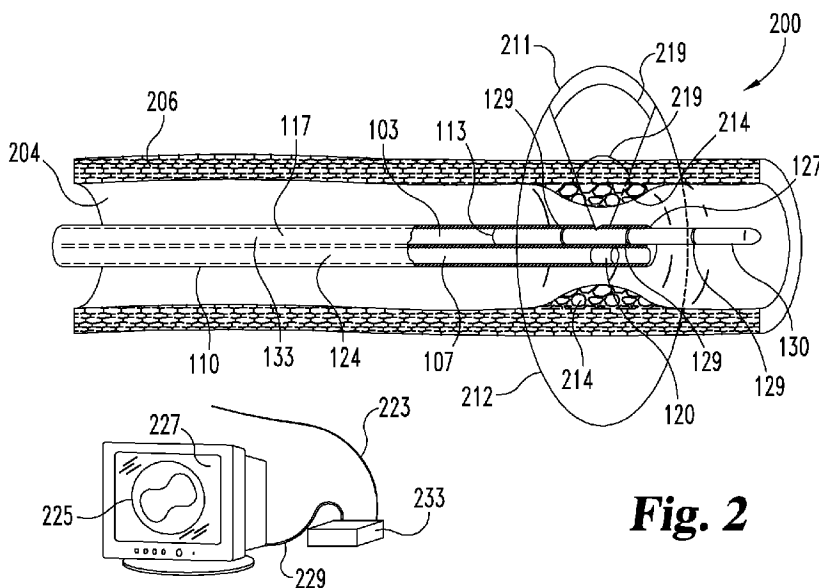
**Declarations under Rule 4.17:**

- as to applicant's entitlement to apply for and be granted a patent (Rule 4.17(ii))
- as to the applicant's entitlement to claim the priority of the earlier application (Rule 4.17(iii))

**Published:**

- with international search report (Art. 21(3))

(54) **Title:** GUIDE MEMBERS AND ASSOCIATED APPARATUSES USEFUL FOR INTRAVASCULAR ULTRASOUND PROCEDURES



**Fig. 2**

(57) **Abstract:** Described are guidewires having at least one echolucent segment, and associated apparatuses and methods. The guidewires can be combined with devices equipped with intravascular ultrasound probes and used to effectively image regions during procedures underway in the vascular environment. The echolucent segment can have one or more echogenic markers to enable detection of the segment and/or relative movement of the segment using intravascular ultrasound.





artifacts may be especially severe if the wire is close to the IVUS transducer further reducing opportunities to obtain usable, and perhaps critically important, clinical information from the ultrasound image.

### SUMMARY

The embodiments disclosed are directed toward guide members, such as guidewires and wire guides having similar function and purpose to those discussed above that are useable in conjunction with intravascular ultrasound procedures but which reduce or eliminate visual artifacts caused by metallic or other echogenic materials. Also included are modes of construction as well as examples of techniques and descriptions of their use.

Embodiments described include guidewires that are at least partially echolucent presenting reduced visual interference in an ultrasound image when the echolucent portion is present within the imageable region. Ultrasonic waves preferably resonate in a frequency range as low as 20khz or as high as 4Ghz, with lower or higher frequencies possible as well depending on factors such as the imaging device used and the clinical objectives to name a few. Sound waves at any frequency cause the molecules of a physical substance they pass through (a “medium”) to vibrate. The density and the speed at which sound travels in the medium dictates how easily sound energy can pass through the medium. As sound waves pass through one medium to another different medium, the energy waves can change velocity causing some of the sound energy to be reflected off the new medium and some to pass through at a new velocity.

For example in a clinical setting, as sounds waves move away from an ultrasonic transducer and through a human or animal, they may encounter several substances along the way such as muscle, bone, various liquids, air or other gases, and the like. Various clinical instruments and apparatus (such as a guidewire) may also be in the path of these waves. As the sound waves travel from one medium to another, such as from human tissue, through bodily fluids, through a guidewire, perhaps through bodily fluids again, and into the same or other human tissue behind the guidewire, the sound waves change speed at the interfaces between the different media. This speed change causes some of the sound energy to be reflected back toward the transducer, while some of the sound energy continues on away from the transducer. Generally speaking, as more sound energy is reflected back to the transducer, the reflecting medium generally appears more distinctly in the resulting ultrasound image. Therefore, materials that are “echolucent” appear less

distinctly because they allow sound waves to travel through them causing fewer echoes. Materials that are “echogenic” allow fewer sound waves to travel through and cause more sound energy to be reflected. For example, as disclosed below, materials reflecting about the same amount of sound energy as soft tissue and fat result in few if any echoes being returned from these materials when they are used in a medical apparatus such as a guidewire inserted in the body adjacent to soft tissue and fat.

Different materials can be chosen to adjust the “echolucence” of a device because doing so changes the characteristic acoustic impedance of the device. The characteristic acoustic impedance of a material or medium is an inherent property of that particular medium and is the product of the density of the medium and the speed of sound in the medium when no sound waves are traveling in it. Measured in Rayleigh (Rayl), 1 Rayl equals 1 newton-second per cubic meter or  $1 \text{ kg/s} \cdot \text{m}^2$ . Therefore the materials used in the construction of a guidewire or other similar apparatus may be varied to adjust the characteristic acoustic impedance of the material, thereby changing the ratio of sound energy passing through the material to the sound energy reflected by it. This can result in a guidewire or similar apparatus creating few if any resulting echoes under ultrasonic imaging thus reducing the visibility of the device. Reduced visibility caused by using echolucent materials makes it possible to image structures behind the guidewire (that is structures opposite the guidewire from the transducer) because sound energy can reach the more distal media by passing through the guidewire both after leaving the transducer and again on the way back to it.

Various materials and modes of construction can be used to vary the echolucent properties of a guidewire or other such apparatus as disclosed. In one example, echogenic markers and marker regions are included along with the echolucent regions of the guide members. These echogenic markers may, for example, be constructed from a medium having a characteristic acoustic impedance that differs widely from that of human or animal flesh. For instance, the characteristic acoustic impedance of air at about room temperature is about 415 Rayl while the characteristic acoustic impedance of certain human or animal tissue can be in the range between about 1.5 to about 1.7 MRayl (or million Rayl) – over

3800 times higher. Thus, examples of guidewires with echogenic markers include guidewires made at least partially of materials having a characteristic acoustic impedance that is approximately equal to that of human flesh where the material also encapsulates or includes one or more voids containing air. Under ultrasound  
5 imaging, the voids (i.e. “bubbles”, or “markers”) enclosed in the material are more visible in the resulting image than the surrounding material which can be substantially invisible, or at least its visibility can be substantially reduced.

Also disclosed are other materials, forms, and configurations besides air bubbles that could be used as markers, this being merely one example. Metallic  
10 flakes, elongated strips, beads, and other arrangements of marking elements or groups of elements embedded within or coupled to an echolucent guide member, or guide member portion, can therefore assist clinicians in tracking and positioning the guide members during imaging while minimizing unwanted artifacts. Also disclosed are embodiments of guide members used in conjunction with two  
15 dimensional and three dimensional intravascular ultrasound imaging devices.

BRIEF DESCRIPTION OF THE FIGURES

Fig. 1 is a longitudinal cross-sectional view of the distal end of one example of a guide member and other apparatuses useful in intravascular ultrasound procedures

5            Fig. 2 is a perspective partial cut-away view of the devices from Fig. 1 introduced within a vascular lumen and connected to imaging equipment.

Fig. 3 is a longitudinal cross-sectional view of the distal end of the guide member from Fig. 1 in use with still other apparatuses useful in intravascular ultrasound procedures.

10           Fig. 4 is a perspective partial cut-away view of the devices from Figs. 1 and 3 introduced within a vascular lumen and connected to the imaging equipment of Fig. 1.

Fig. 5A – 7C are perspective views of other embodiments of the guide member shown in Figs. 1 – 4 .

15

### DETAILED DESCRIPTION

For the purpose of promoting an understanding of the principles of the invention, reference will now be made to embodiments, some of which are illustrated in the drawings, and specific language will be used to describe the same.

5 It will nevertheless be understood that no limitation of the scope of the invention is thereby intended. Any alterations and further modifications in the described embodiments, and any further applications of the principles of the invention as described herein are contemplated as would normally occur to one skilled in the art to which the invention relates.

10 Illustrated in Fig. 1 at **100** is one embodiment of a guide member **133** along with other associated apparatuses useful for intravascular ultrasound procedures in an animal or human patient. Guide member **133** is shown having a segmented arrangement of individual portions or segments joined together, these portions themselves may then also include other portions or segments as well depending on  
15 the materials used, the mode of construction, and the intended use. In the embodiment shown in Fig. 1, a first guide body portion **130** forming the distal end of guide member **133** is coupled to a second guide body portion **103**, with the two segments joined to one another at joint **113**. First guide body portion **130** has one or more longitudinally spaced discrete echogenic markers **129** interspersed along  
20 its length which are operable to appear during ultrasonic imaging procedures. Guide member **133** may be positioned within a first lumen **117** and can extend beyond distal end **127** of an elongate carrier body **110**. Elongate carrier body **110** can serve various functions such as maintaining an association between guide member **133** and an intravascular ultrasound probe **107** positioned within a second  
25 lumen **124**. By maintaining this association, guide member **133** can aid in maneuvering intravascular ultrasound probe **107** into position within the patient's body.

Intravascular ultrasound probe **107** positioned within second lumen **124** has at its distal end an ultrasonic transducer **120** which is operable to emit ultrasonic  
30 energy and detect the reflected energy for the purpose of performing ultrasonic imaging of interior spaces of a patient's anatomy such as organs, blood vessels, and the like. Ultrasonic transducer **120** is preferably positioned distal to joint **113** so

that ultrasonic energy emitted from ultrasonic transducer **120** passes through carrier body **110** and first guide body portion **130** but not through second guide body portion **103**.

Elongate carrier body **110** can be constructed of any material suitable for intravascular introduction and navigation through blood vessels, organs, and other structures within a patient's body. Suitable materials include, but are not limited to, polyurethane, nylon, polyethylene, and silicone. Preferably elongate carrier body **110** includes echolucent materials to reduce or substantially eliminate sound energy reflected by the echolucent portion of carrier body **110**. By including echolucent material in elongate carrier body **110** in those regions where ultrasonic energy resonates from transducer **120**, ultrasonic waves can pass substantially unimpeded through carrier body **110** allowing the tissue surrounding carrier body **110** to be imaged.

One embodiment of elongate carrier body **110** is a catheter having multiple lumens extending through some or all of the length of the catheter and exiting at or near the catheter's distal end. In this embodiment, the catheter acts to keep guide member **133** and intravascular ultrasound probe **107** properly positioned relative to one another such that guide member **133** can be used to help advance elongate carrier body **110**. Elongate carrier body **110** can then be useful for properly advancing intravascular ultrasound probe **107** to its intended region within the body. Other embodiments of elongate carrier body **110** include catheters having an intravascular ultrasound probe **107** embedded in, or otherwise coupled with, the catheter itself.

Fig. 1 illustrates a first guide body portion **130** that includes an echolucent material. An echolucent material includes any material having a characteristic acoustic impedance substantially similar or about equal to the characteristic acoustic impedance of the surrounding material (e.g. bone, blood, muscle, bodily fluids, or other human or animal anatomical features of interest). Thus as sound waves pass through from the surrounding media and through first guide body portion **130**, the change in speed of the high frequency sound waves is minimized resulting in fewer echoes being returned to transducer **120** from guide body portion **130**. The results include ultrasound images where guide body portion **130** may be

substantially or completely invisible. This allows the surrounding tissue or other anatomical structures of interest to be imaged rather than guide body portion **130**.

In one example, the echolucent material in first guide body portion **130** may have a characteristic acoustic impedance of between about 1.5 MRayl and about 2.2 MRayl, which is approximately the range of characteristic acoustic impedances for many types of human or animal tissue. Examples of such echolucent materials include Polyethylene (PE), Polymethylpentene, and Ethyl Vinyl Acetate. In another example, the echolucent material in first guide body portion **130** may have a characteristic acoustic impedance of between about 1 MRayl and about 5 MRayl, although such a material may cause reduced performance making guide body portion **130** more visible during ultrasonic imaging procedures. Examples of such materials include Acrylic, Polyvinyl Chloride (PVC), Polycarbonate, Nylon, Polystyrene, Vinyl, and Acrylonitrile Butadiene Styrene (ABS). First guide body portion **130** may, for example, include a polymeric material having a density in the range of 0.5 grams/cc to 3.5 grams/cc. In another embodiment, first guide body portion **130** includes polyethylene or another polymeric material having a density in the range of about 0.8 grams/cc to about 1.1 grams/cc.

In other embodiments, first guide body portion **130** may include other echogenic structures or substances to modify the number and strength of reflected sound waves. Making a first guide body portion **130** disappear entirely from the resulting image may be undesirable and may result in a substantial reduction or complete loss of positional feedback. As a result, the clinician may, in such situations, be unable to properly maneuver and position first guide body portion **130** during the ultrasonic imaging procedure.

Providing positional feedback using the ultrasonic imaging system may be achieved in various ways such as through the use of echogenic markers or marker regions as discussed below. However, it may also be advantageous to optionally include an echo-opacifier into the polymeric material used to construct first guide body portion **130** to precisely control its characteristic acoustic impedance. Examples of echo-opacifiers that might be used include tungsten nanoparticles, glass or ceramic beads, or gas filled voids or other similar structures or materials

included with guide body portion **130**. By varying the concentration, placement, size and other aspects of the additives or structures, the acoustic impedance and corresponding echogenicity and echolucence may be modified to control the resulting appearance of first guide body portion **130** in an ultrasound image.

5           The echolucence may also be reduced and echogenicity increased by using materials with characteristic acoustic impedances that differ from the characteristic acoustic impedance of the human or animal tissue in the surrounding region. For example, constructing a guide body portion **130** from PVC, which has a characteristic acoustic impedance of about 3 MRayl, can provide additional  
10       visibility of first guide body portion **130** for the clinician while still allowing some of the sound waves to pass through making it still possible to image the area behind guide body portion **130**.

          In other embodiments, other materials or structures may also be included in first guide body portion **130** to modify its visibility with respect to other types of  
15       imaging technologies such as to make first guide body portion **130** partially or completely radio opaque. Such an embodiment may be useful where two different imaging technologies (e.g. ultrasonography and radiography) are used during the same procedure. For example, first guide body portion **130** may be constructed of Polyethylene (which has a characteristic acoustic impedance of about 1.73 MRayl)  
20       that also includes Barium sulfate or other similar radio-opacifier. The resulting guide wire may therefore be echolucent returning very few echoes to transducer **120** presenting a reduced or minimally visible ultrasound image while also being visible during X-ray imaging.

          Tracking the position of first guide body portion **130** may also be achieved  
25       by including one or more echogenic markers **129** spaced longitudinally along the long axis of first guide body portion **130**. Although Fig. 1 illustrates a first guide body portion **130** having three echogenic markers **129**, the precise number of echogenic markers **129** shown in Fig. 1 is only illustrative. In some embodiments only one echogenic marker **129** may appear while in other embodiments numerous  
30       markers, or groups of markers, may be included. (See Figs. 5A through 7C and the accompanying description below for examples.)

Echogenic markers **129** include individual flakes of metal of the proper size and shape affixed to or embedded within guide member **133**, metal beads or plugs embedded within guide member **133**, metal strands or fibers adhered to the external surface of guide member **133**, or metal strands or fibers embedded within the interior of guide member **133**. Various metals might be used as an echogenic material for echogenic markers **129**. For example, substances such as stainless steel or a nickel and titanium alloy like nitinol might be formed into flakes, strands, fibers, or other forms and embedded, attached, adhered, or otherwise coupled and included with guide member **133** to form echogenic markers **129**.

Other embodiments of echogenic markers **129** include a first guide body portion **130** of guide member **133** where each echogenic marker **129** includes one or more echogenic structures such as one or more empty or gas filled spaces or "bubbles" at the proper positions along the length of guide member **133**. These bubbles may be of various sizes such as large and individually positioned bubbles where each individual bubble serves as an echogenic marker **129**, or individually small bubbles arranged together to form rings, lines, or other shapes serving as echogenic markers **129** (See Figs. 5C – 7B). The bubbles themselves may define an empty space containing a near vacuum, or be filled with a small quantity of gas, or contain any type of matter having a characteristic acoustic impedance that substantially differs from the surrounding tissue.

Other embodiments of guide member **133** are envisioned as well. For example, it is envisioned that in another embodiment of guide member **133** no joint **113** exists. In this embodiment, first guide body portion **130** is a single first guide body segment formed of echolucent material and has associated with it at least one echogenic marker **129**. In this embodiment, no concern need be given to the positioning of guide member **133** relative to ultrasonic transducer **120** (discussed in greater detail below with regard to Figs. 2 and 4) because all of guide member **133** is echolucent and no second guide body portion **103** is included. One example of such a guide member **133** is a guidewire for use in an intravascular ultrasound procedure formed from an echolucent material with one or more echogenic markers associated with the guidewire, preferably at or near its distal end. One example of such a guidewire is a polyethylene guidewire having a single echogenic

marker formed from a nitinol bead embedded within the guidewire near its distal end.

In the embodiment illustrated in Fig. 1, second guide body portion **103** may be formed from an echogenic material, or other similar material. In one preferred  
5 embodiment, second guide body portion **103** includes a metal or metallic substance such as a material containing a combination of polymeric (or other nonmetallic) and metallic fibers. Examples of a guide member **133** having echogenic properties include a guidewire constructed of strands or coils of stainless steel or nitinol, or other similarly echogenic material, having a segment coupled to the distal end  
10 constructed from Polyethylene or other similar echolucent material.

Shown in Fig. 2 is an illustration of the apparatus illustrated in Fig. 1 in use during a procedure such as an intravascular procedure to image internal areas of a human or animal patient's body. Elongate carrier body **110** is shown in Fig. 2 introduced into a vascular vessel **200** having a vascular lumen **204** with a vascular  
15 wall **206** and a vascular blockage **214**. Guide member **133** is shown projecting from the distal end of elongate carrier body **110** beyond intravascular ultrasound probe **107**. As ultrasonic transducer **120** of intravascular ultrasound probe **107** is energized, ultrasonic energy waves **219** begin to radiate outwardly from intravascular ultrasound probe **107** through elongate carrier body **110** into and  
20 through an imageable region **212** which is external to elongate carrier body **110** and extends through the contents of vascular lumen **204**, through vascular wall **206** and perhaps beyond. Depending on the particular implementation of intravascular ultrasound probe **107** in use, the imageable region may at any time include only a partial imageable region **211** of the total imageable region **212**. Therefore, some  
25 embodiments of intravascular ultrasound probe **107** must be rotated repeatedly to obtain updated views of the entire imageable region **212**. In one embodiment of intravascular ultrasound probe **107**, updated views of the imageable region **212** are generated automatically by an ultrasonic transducer **120** having an array of one or more radiating elements configured to electronically sweep imageable region **212**  
30 without rotating ultrasonic transducer **120**. In another embodiment of intravascular ultrasound probe **107**, updated image data from imageable region **212** is generated by manually rotating ultrasonic transducer **120** such as by the clinician applying

rotational torque on ultrasound probe **107**, or by the use of a rotational device such as an electric motor coupled to ultrasound probe **107**.

Regardless of how much or little of imageable region **212** is scanned or imaged at any given time, in this embodiment of intravascular ultrasound probe **107**, the imageable region is a substantially two-dimensional cross-sectional slice which can include the vascular lumen **204** and its contents, vascular wall **206**, as well as any abnormalities in vascular wall **206** such as vascular blockage **214**. The cross-sectional slice is imaged at the approximate location of ultrasonic transducer **120** as indicated by the location of imageable region **212**. It should be noted that although Fig. 2 indicates an apparent maximum extent of the imageable region **212**, no assumption should be made from the illustration as to whether such a maximum range exists, nor how far it extends. Many factors determine the sensory capabilities of an ultrasonic imaging probe in general. Among them are the unique attributes of a particular patient, the particular location within the body relative to various organs and structures, the power and frequency of the emitted energy, as well as various other operational settings of the particular embodiment of ultrasonic transducer **120** in use. Thus no particular assumption should be made as to the degree to which imageable region **212** extends beyond the walls of elongate carrier body **110**.

The result of penetrating imageable region **212** with ultrasonic energy waves **219** and detecting the return echoes may include image data indicating various information such as the extent to which vascular blockage **214** extends into vascular lumen **204**, and the type of material vascular blockage **214** is composed of, to name a few examples. In order to collect this information, elongate carrier body **110** is coupled to an image data interface device **233** through a transducer link **223** such as a data cable or wireless data link that is operable to transmit data from transducer **120** to data interface device **233**. Data interface device is also coupled to image data display device **227** by a connecting member **229** such as a data cable, wireless data link, or other similar device able to transmit data to data display device **227**. Return echoes from objects within the imageable region **212** are converted to a data stream by image data interface device **233** and the data is then passed to image data display device **227** where the data is processed into

image data **225** and displayed as an image of imageable area **212** for the clinician to view, review, save for the patient to view later, archive in medical records, or use for other purposes.

In some embodiments, image data display device **227** is a general purpose computer capable of operating specialized software able to capture data received through connecting member **229** from image data display device **227**, process the data into one or more images, and display this image data **225**. In other embodiments, image data display device **227** is a specialty built computer designed and built for only the purpose of capturing image data from connecting member **229** and processing the data into image data **225**. In either case, image data **225** is processed into any of various visual representations such as still frames containing individual snapshots of imageable region **212**, or as a stream of image data **225** appearing on image data display device **227** as a moving image. In the case of a moving image, image data **225** is preferably refreshed with new data from imageable region **212** at a rate of greater than 15 frames per second, more preferably greater than 20 frames per second, and most preferably 30 frames per second or more.

The use of guide member **133** is shown in Fig. 2 where guide member **133** has been introduced into the body along with elongate carrier body **110** and intravascular ultrasound probe **107**. It is commonly the case that guide member **133** is introduced into the body first, followed by elongate carrier body **110**, possibly then followed by intravascular ultrasound probe **107**. It is also common for guide member **133** to be advanced some distance through the body ahead of elongate carrier body **110** before the elongate carrier body and intravascular ultrasound probe **107** are then advanced together as well. The sequence of advancing guide member **133** followed by elongate carrier body **110** is then repeated until the area of interest is reached, or until the procedure is complete for in some cases the purpose of advancing intravascular ultrasound probe **107** is to obtain image data throughout the journey. Navigation of guide member **133** throughout this process is frequently aided by other imaging techniques such as fluoroscopy, MRI imaging, and the like. Upon arriving at the area to be imaged, or possibly in some cases throughout the journey, guide member **133** extends beyond

distal end of elongate carrier body **110** as shown in Fig. 2. Intravascular ultrasound probe **107** can then be activated (if it is not already active) causing image data **225** to begin appearing on image data display device **227**.

As can be seen in Fig. 2, joint **113** can be positioned proximal to ultrasonic transducer **120** and is therefore proximal to imageable region **212**. By this relative positioning of guide member **133** and intravascular ultrasound probe **107**, first guide body portion **130** comprising an echolucent material is the only portion of guide member **133** within imageable region **212**. As a result, ultrasonic energy emitted by ultrasonic transducer **120** passes through first guide body portion **130** rather than being reflected by it, and therefore first guide body portion **130** does not substantially interfere with image data **225**. This result is preferable insofar as it avoids extraneous information appearing within image data **225** that may obscure more important information, make important information more difficult to discern, or otherwise interfere with image data **225**. However, if guide member **133** is positioned such that joint **113** is distal to ultrasonic transducer **120**, second guide body portion **103** will be positioned within imageable region **212**. Extraneous information will then begin to appear in image data **225** because second guide body portion **103** is composed of an echogenic material that will not allow some or all of the ultrasonic energy emitted by ultrasonic transducer **120** to pass through it thus causing interference to appear within with image data **225**.

In some cases it may be preferable for the clinician to have a visual cue appearing within image data **225** indicating the location of the echolucent portion of guide member **133** within vascular lumen **204**. This potential need is facilitated by a plurality of longitudinally spaced echogenic markers **129** which may also be implemented as marker regions having groups of markings arranged in various patterns such as a helix, lines, stripes, dots and the like (examples of various embodiments of echogenic markings are shown in Figs. 5A through 7C).

Ultrasonic energy **219** passes through first guide body portion **130** but is reflected back to intravascular ultrasonic transducer **120** by any echogenic markers **129** in the path of emitted ultrasonic energy **219**. Because of their small size relative to guide member **133**, echogenic markers **129** appear in image data **225**, and therefore indicate the position of first guide body portion **130** without causing substantial

visual interference. Echogenic markers **129** therefore aid the clinician in maneuvering guide member **133** while still maintaining visual cues within image data **225** that do not cause substantial visual interference.

Depending on the type of ultrasonic transducer used, the image data  
5 collected may be a series of two dimensional cross-sectional slices captured at various points within the patient's body and then displayed. In other embodiments, the ultrasonic transducer may be capable of generating image data which includes a three dimensional or volumetric representation of the area of interest. An example of a device having these capabilities is illustrated in Fig. 3 and shown in  
10 operation in Fig. 4 and described below.

Illustrated in Fig. 3 at **300** is an example of use the guide member **133** illustrated in Fig. 1 in conjunction with a forward-looking ultrasound transducer. Guide member **133** extends beyond the distal end of an elongate carrier body **304** having an internal lumen **311** and an intravascular ultrasound probe **320** at distal  
15 end **327**. Intravascular ultrasound probe **320** includes a forward-looking transducer array **325** arranged annularly around distal end **327** of elongate carrier body **304**. Guide member **133** extends past forward-looking transducer array **325** thereby allowing ultrasonic energy emanating from forward-looking transducer array **325** to pass through and around first guide body portion **130**. As in Figs. 1 and 2, joint  
20 **113** appears proximally to intravascular ultrasound probe **320** such that second guide body portion **103** composed of echogenic material is proximal to forward-looking transducer array **325** while first guide body portion **130** composed primarily of echolucent material passes through distal end **327** and is distal to forward-looking transducer array **325**. Rather than an ultrasonic transducer that  
25 radiates ultrasonic energy laterally through the side walls of the elongate carrier body **304** (as in Figs. 1 and 2), an array of multiple transducers are arranged to emit ultrasonic energy forward of transducer array **325** toward the region distal to distal end **327**.

One embodiment of intravascular ultrasound probe **320** contains an array of  
30 Capacitive Micromachined Ultrasonic Transducers (CMUT) arranged in a forward-looking transducer array **325** such that ultrasonic energy is directed longitudinally ahead of transducer array **325** and carrier body **304**. Ultrasonic

energy is emitted and detected by elements in the array **325** which are controlled by integrated circuits **317**. Other types of transducers and transducer arrays may be used as well such as piezoelectric transducers. In this example of elongate carrier body **304**, the CMUT transducer array is positioned at the distal end of a single lumen catheter. Other configurations are also envisioned such as multi-lumen catheters, or a forward-looking transducer array positioned next to the distal end rather than annularly around it.

Fig. 4 illustrates how the devices shown in Fig. 3 could be used in an imaging procedure such as intravascular imaging of a partially blocked internal lumen in a patient such as a vascular vessel. A blood vessel **400** appears in Fig. 4 which is similar to the vessel appearing in Fig. 2. Blood vessel **400** has a vascular lumen **404**, within which has been introduced elongate carrier body **304** having an intravascular ultrasound probe **320** coupled to its distal end. Intravascular ultrasound probe **320** includes a forward-looking transducer array **325**. Ultrasonic waves **419** are generated by forward-looking transducer array **325** creating a three-dimensional imageable region **411** into which is positioned guide member **133**. Parts of vascular wall **406** and vascular blockage **414** are also within imageable region **411** as shown in Fig. 4 given their relative position to transducer array **325**.

As forward-looking transducer array **325** is activated, ultrasonic energy waves **419** begin to radiate from intravascular ultrasound probe **320** beyond distal end **327** of elongate carrier body **304** and into and through imageable region **411**. Imageable region **411** is external to elongate carrier body **304** and includes the contents of vascular lumen **404**, vascular wall **406**, vascular blockage **414**, and possibly the contents of structures and tissues outside vascular vessel **400**. The behavior of each individual transducer within the forward-looking transducer array **325** is coordinated by integrated circuits **317** so that intravascular ultrasound probe **320** operates to image all of imageable area **411** as a three-dimensional region capturing properties of the structures within the region such as volumes, densities, rates of flow of fluids through vascular lumen **404**, shapes, sizes, lengths, and other properties of objects found within the region that may be determined. It should be noted that although Fig. 4 indicates an apparent maximum extent of the imageable region **411**, no assumption should be made from the illustration as to whether such

a maximum range exists, nor to what extent it reaches. Many factors determine the sensory capabilities of an ultrasonic imaging probe in general. Among them are the unique attributes of a particular patient, the particular location within the body relative to various organs and structures, as well as the power and construction of the forward-looking transducer array **325**. Thus no particular assumption should be made as to the degree to which imageable region **411** extends beyond distal end **327**.

The result of penetrating imageable region **411** with ultrasonic energy and sensing the return echoes is three-dimensional image data **425** indicating various information such as the extent to which vascular blockage **414** extends into vascular lumen **404**, the type and density of the material vascular blockage **414** is made of, and various other related information. In order to collect this information, elongate carrier body **110** is coupled to an image data interface device **233** through a transducer link **223** as described above. The data interface device **233** is in turn coupled to image data display device **227** by connecting member **229**, also as described above. Return echoes from within imageable region **411** are converted to a data stream by image data interface device **233** and the data is then passed to image data display device **227**. The data is then processed into three-dimensional image data **425** and displayed as a three-dimensional image of imageable area **411**, or possibly also viewed as a collection of two-dimensional images, or "slices", extracted from the three-dimensional image data **425**. The clinician may then view, review, or save the images or the data for the patient to view later, archive in medical records, or use for other purposes.

During the use of guide member **133** shown in Fig. 4, the clinician may introduce elongate carrier body **304** into the body at an appropriate point by various methods depending on the procedure required. The clinician may also introduce guide member **133** through first lumen **311** at the same time, or at another time as well. The precise order of activities used to introduce guide member **133** is unimportant to the use of the system for collecting information. Elongate carrier body **304** is advanced through the body, preferably through a vascular lumen such as a blood vessel, to the area of the body to be imaged by intravascular ultrasound probe **320**. This navigation is facilitated by guide member

**133** which is often introduced well ahead of elongate carrier body **320** for the purpose of guiding it through the body. The navigation of guide member **133** may also be aided through imaging performed by other means such as by fluoroscopy, MRI imaging, and the like. In many cases it may be advantageous to operate  
5 intravascular ultrasound probe **320** to obtain image data as the elongate carrier body **304** is advanced as well.

Fig. 4 illustrates the operation of intravascular ultrasound probe **320** in conjunction with guide member **133**. It can be seen in Fig. 4 (as in Fig. 2) that joint **113** is preferably positioned proximally to ultrasonic transducer **320** and is  
10 therefore proximal to imageable region **411**. By this relative positioning of guide member **133** and intravascular ultrasound probe **320**, first guide body portion **130** including echolucent material is the only portion of guide member **133** within imageable region **411**. As a result, ultrasonic energy **419** emitted from forward-looking transducer array **325** passes primarily through first guide body portion **130**  
15 rather than being substantially reflected by it and therefore first guide body portion **130** does not substantially interfere with image data **425**. This result is preferable insofar as it avoids excessive extraneous information appearing within image data **425** that may otherwise obscure important information or make important information more difficult to discern. However, if guide member **133** is positioned  
20 with joint **113** distal to forward-looking transducer array **325**, extraneous information, "noise," "shadows," or other interference may begin to appear in image data **425** if second guide body portion **103** is composed of echogenic material that blocks the passage of ultrasonic energy **419** through guide member **133** causing it to appear in, or interfere with, resulting image data **425**.

25 As discussed above with regard to Fig. 2, in some cases it may be preferable for the clinician to maintain visual cues within image data **425** indicating the location of the echolucent portion of guide member **133** within vascular lumen **404**. This may be especially useful where the clinician is operating an automated imaging system that may rely on the echogenic markers in order to  
30 automatically position intravascular ultrasound ultrasonic probe **320**. Therefore, as noted above, at least one, and possibly more than one, longitudinally spaced echogenic marker **129** is provided as part of first guide body portion **130** of guide

member **133**. Echogenic markers **129** may be individual markings or marker regions having groups of markings arranged in various patterns such as a helix, lines, stripes, dots and the like (examples of various embodiments of echogenic markers and marker regions are shown in Figs. 5A through 7C). Some or all of ultrasonic energy **419** can then pass through the rest of guide member **133** with small amounts being reflected back to ultrasonic transducer array **325** by echogenic markers **129** or optionally by guide member **133** as well depending on its construction. Because of their small size relative to first guide body portion **130**, echogenic markers **129** appear in image data **425** and therefore indicate the position of first guide body portion **130** but without causing substantial visual interference. Echogenic markers **129** thereby aid the clinician in maneuvering guide member **133** through vascular lumen **404** by maintaining visual cues within three-dimensional image data **425**.

Various types of visual cues may be required depending on a number of factors such as whether the imageable region is two-dimensional or three-dimensional, the location to be imaged within the body, the type of structures to be imaged, and others. Illustrated in Figs. 5A through 7C are various examples of guide members similar to guide member **133** having various arrangements of echogenic markers and marker regions. In each of these embodiments described in the following Figs. 5A through 7C, as with echogenic markers **129** shown in Figs. 1 through 4 above, echogenic markers have various modes of construction. For example an echogenic marker that appears as a ring (such as echogenic marker **129** in Fig. 1 through Fig. 4) may be created by adhering a narrow band of echogenic material such as metal, or other acoustically reflective material, to the exterior surface of the guide member (such as guide member **133** in Fig. 1). Likewise, a similar effect may be achieved by embedding a narrow band of echogenic material within or beneath the surface of the guide member. Other embodiments are also envisioned such as a void within the guide member filled with a vacuum, or a gas such as nitrogen, air, or other gas, or a small piece of echogenic material such as a metal bead, metal flakes, or other echogenic material within the body of the guide member. These various modes of construction can be used together as well in various combinations to create the echogenic markers described.

Illustrated in Figs. 5A, 5B, and 5C, are examples of a guide member **500** having a first guide body portion **510**, joined to a second guide body portion **503** at joint **504**. A continuous longitudinally extending echogenic marker **506** appears as well. In Fig. 5A, echogenic marker **506** appears as a single continuous unbroken ribbon or band extending along first guide body portion **510** substantially parallel to the longitudinal axis of first guide body portion **510**. As described above, echogenic marker **506** may be created by attaching echogenic material to the exterior of guide member **500**, by embedding echogenic material within the guide member **500**, or by manufacturing guide member **500** with echogenic structures or materials within first guide body portion **510**. Other techniques may be used as well for causing echogenic marker **506** to appear during imaging as well. In Fig. 5B, echogenic marker **506** is a single continuous longitudinally extending echogenic marker defining a helical pattern. A similar echogenic marker **506** appears in Fig. 5C comprising a continuous longitudinally extending echogenic marker **506** here embodied as a marker pattern having a pattern of echogenic marker elements **508** separated by discontinuities in the marker material or structure. In this embodiment, each individual echogenic marker element **508** is part of a single echogenic marker **506**. Each "dot" (marker element **508**) in Fig. 5C may be an individual metal flake, metal bead, gas bubble, or other echogenic material or structure as described above with respect to markers **129**.

In Fig. 6A, 6B, and 6C, guide member **600** is illustrated having a first guide body portion **610** with an echogenic marker **606** embodied as a marker pattern with one or more longitudinally spaced echogenic marker regions **605**. Marker regions **605** include one or more echogenic marker elements **608**. Similar to previously mentioned embodiments, first guide body portion **610** is joined to a second guide body portion **603** at joint **604**. As illustrated, marker elements **608** may be separated from one another by discontinuities in the echogenic material or structure. Each of the individual marker elements **608** are constructed as discussed above with respect to marker elements **508** and markers **129**. Each individual echogenic marker element **608** in Fig. 6A can therefore be thought of as an echogenic "dot". In Fig. 6B and 6C, each individual echogenic marker element

**608** is an echogenic ring, or individual dots arranged annularly in one or more ring patterns within each marker region **605**.

Figs. 7A, 7B, and 7C also illustrate various arrangements of discrete echogenic markers **708** spaced along a first guide body portion **710** of a guide member **700** also having a second guide body portion **703** joined to the first guide body portion **710** at joint **704**. In Fig. 7A and 7B, multiple echogenic markers **708** are illustrated as individual echogenic "dots" as discussed above. In Fig. 7B, the echogenic markers **708** are positioned in a helical marker pattern rather than in a straight line shown in Fig. 7A. In Fig. 7C, each echogenic marker **708** is a  
5 configured as a band disposed around at least a portion of the perimeter or circumference of guide member **700**. As with Fig. 5C, each "dot" or ring illustrated in Fig. 7A through 7C indicates an individual echogenic marker **708** formed from an echogenic substance or structure as described above such as a ring of metal, solid bead of metal, a bubble of air, metal flake, or void filled with a gas,  
10 a vacuum, or other echogenic substance.

The uses of the terms "a" and "an" and "the" and similar references in the context of describing the invention (especially in the context of the following claims) are to be construed to cover both the singular and the plural, unless otherwise indicated herein or clearly contradicted by context. Recitation of ranges  
20 of values herein are merely intended to serve as a shorthand method of referring individually to each separate value falling within the range, unless otherwise indicated herein, and each separate value is incorporated into the specification as if it were individually recited herein. All methods described herein can be performed in any suitable order unless otherwise indicated herein or otherwise clearly  
25 contradicted by context. The use of any and all examples, or exemplary language (e.g., "such as") provided herein, is intended merely to better illuminate the invention and does not pose a limitation on the scope of the invention unless otherwise claimed. No language in the specification should be construed as indicating any non-claimed element as essential to the practice of the invention.

30 While the invention has been illustrated and described in detail in the drawings and foregoing description, the same is to be considered as illustrative and not restrictive in character, it being understood that only the preferred embodiment

has been shown and described and that all changes and modifications that come within the spirit of the invention are desired to be protected. In addition, all references cited herein are indicative of the level of skill in the art and are hereby incorporated by reference in their entirety.

5           The following numbered clauses set out specific embodiments as discussed above that may be useful in understanding the present disclosure:

1.       An intravascularly-introducible apparatus, comprising:  
          an elongate carrier body for intravascular passage, the carrier body defining  
10       at least one lumen and carrying at least one intravascular ultrasound probe for  
          generating image data representing an imageable region external of the carrier  
          body; and  
          a guide member having an elongate guide body receivable through said  
          lumen, the elongate guide body having at least a first guide body portion capable of  
15       passage into said imageable region;  
          wherein said first guide body portion includes an echolucent material and  
          has associated therewith at least one echogenic marker.
2.       The apparatus of clause 1, wherein elongate guide body comprises at least  
20       two longitudinally-extending guide body portions joined to one another.
3.       The apparatus of clause 2, further comprising:  
          a second guide body portion formed of an echogenic material;  
          wherein said elongate guide body includes at least said first guide body  
25       portion joined to said second guide body portion.
4.       The apparatus of clause 2 or 3, wherein the first guide body portion  
          includes a polymeric material, and the second guide body portion includes a metal.
- 30       5.       The apparatus of any preceding clause, wherein the at least one echogenic  
          marker includes a plurality of longitudinally spaced echogenic marker regions.

6. The apparatus of any one of clauses 1 through 4, wherein the at least one echogenic marker includes a plurality of discrete echogenic markers or a continuous longitudinally-extending echogenic marker.
- 5 7. The apparatus of clause 6, wherein the at least one echogenic maker includes said continuous longitudinally-extending echogenic marker, and wherein the longitudinally-extending echogenic marker defines a helical pattern.
8. The apparatus of any preceding clause, wherein the elongate carrier body is  
10 a catheter.
9. The apparatus of any preceding clause, wherein the imageable region is a substantially two-dimensional cross-sectional slice.
- 15 10. The apparatus of any one of clauses 1 through 8, wherein the imageable region is three-dimensional.
11. The apparatus of any one of clauses 1-10, wherein the imageable region includes a region forward of the ultrasound probe.  
20
12. The apparatus of any preceding clause, wherein the first guide body portion includes a polymeric material having a density in the range of 0.5 grams/cc to 3.5 grams/cc.
- 25 13. The apparatus of any preceding clause, wherein the first guide body portion includes polyethylene having a density in the range of about 0.8 grams/cc to about 1.1 grams/cc.
14. A guidewire in an intravascular ultrasound procedure, comprising:  
30 an elongate guide body configured to traverse a vascular vessel, the elongate guide body having at least a first guide body portion including an echolucent material; and

at least one echogenic marker associated with the first guide body portion.

15. The guidewire of clause 14, wherein elongate guide body comprises at least two longitudinally-extending guide body portions joined to one another.

5

16. The guidewire of clauses 14 or 15, further comprising:  
a second guide body portion formed of an echogenic material;  
wherein said elongate guide body includes at least said first guide body portion joined to said second guide body portion.

10

17. The guidewire of clauses 15 or 16, wherein the first guide body portion includes a polymeric material, and the second guide body portion includes a metal.

18. The guidewire of any one of clauses 14 through 17, wherein the at least one echogenic marker includes a plurality of longitudinally spaced echogenic marker regions.

15

19. The guidewire of any one of clauses 14 through 17, wherein the at least one echogenic marker includes a plurality of discrete echogenic markers or a continuous longitudinally-extending echogenic marker.

20

20. The guidewire of clause 19, wherein the at least one echogenic maker includes said continuous longitudinally-extending echogenic marker, and wherein the longitudinally-extending echogenic marker defines a helical pattern.

25

21. The guidewire of any one of clauses 14 through 20, wherein the first guide body portion includes a polymeric material having a density in the range of 0.5 grams/cc to 3.5 grams/cc.

30

22. The guidewire of any one of clauses 14 through 21, wherein the first guide body portion includes polyethylene having a density in the range of about 0.8 grams/cc to about 1.1 grams/cc.

23. An intravascular procedure, comprising:  
introducing into a vascular vessel an elongate guide body having at least a  
first guide body portion including an echolucent material and having at least one  
5 echogenic marker associated with the first guide body portion; and  
imaging a region within the vascular vessel with an intravascular  
ultrasound probe, wherein during said imaging at least part of said first guide body  
portion is positioned in said region.
- 10 24. The method of clause 23, wherein said elongate guide body is comprised of  
at least two longitudinally-extending guide body portions joined to one another.
25. The method of clause 24, further comprising:  
a second said guide body portion formed of an echogenic material;  
15 wherein said elongate guide body includes said guide body portion joined  
to said second guide body portion.
26. The method of clause 24 or 25, wherein the first guide body portion  
includes a polymeric material, and the second guide body portion includes a metal.  
20
27. The method of any one of clauses 24 to 26, wherein the at least one  
echogenic marker includes a plurality of longitudinally spaced echogenic marker  
regions.
- 25 28. The method of any one of clauses 24 to 26, wherein the at least one  
echogenic marker includes a plurality of discrete echogenic markers or a  
continuous longitudinally-extending echogenic marker.
- 30 29. The method of clause 28, wherein the at least one echogenic maker  
includes said continuous longitudinally-extending echogenic marker, and wherein  
the longitudinally-extending echogenic marker defines a helical pattern.

30. The method of any one of clauses 24 to 29, wherein the first guide body portion includes a polymeric material having a density in the range of 0.5 grams/cc to 3.5 grams/cc.
- 5 31. The method of any one of clauses 24 to 30, wherein the first guide body portion includes polyethylene having a density in the range of about 0.8 grams/cc to about 1.1 grams/cc.

What is claimed is:

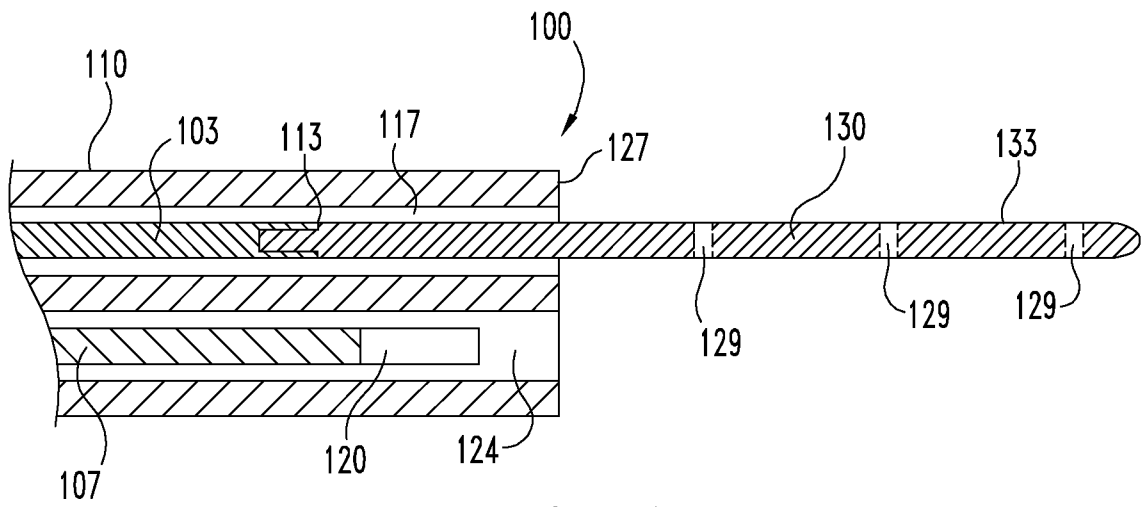
1. An intravascularly-introducible apparatus, comprising:  
an elongate carrier body for intravascular passage, the carrier body defining  
5 at least one lumen and carrying at least one intravascular ultrasound probe for  
generating image data representing an imageable region external of the carrier  
body; and  
a guide member having an elongate guide body receivable through said  
lumen, the elongate guide body having at least a first guide body portion capable of  
10 passage into said imageable region;  
wherein said first guide body portion includes an echolucent material and  
has associated therewith at least one echogenic marker.
2. The apparatus of claim 1, wherein elongate guide body comprises at least  
15 two longitudinally-extending guide body portions joined to one another.
3. The apparatus of claim 2, further comprising:  
a second guide body portion formed of an echogenic material;  
wherein said elongate guide body includes at least said first guide body  
20 portion joined to said second guide body portion.
4. The apparatus of claim 2 or 3, wherein the first guide body portion includes  
a polymeric material, and the second guide body portion includes a metal.
- 25 5. The apparatus of any preceding claim, wherein the at least one echogenic  
marker includes a plurality of longitudinally spaced echogenic marker regions.
6. The apparatus of any one of claims 1 through 4, wherein the at least one  
echogenic marker includes a plurality of discrete echogenic markers or a  
30 continuous longitudinally-extending echogenic marker.

7. The apparatus of claim 6, wherein the at least one echogenic maker includes said continuous longitudinally-extending echogenic marker, and wherein the longitudinally-extending echogenic marker defines a helical pattern.
- 5 8. The apparatus of any preceding claim, wherein the elongate carrier body is a catheter.
9. The apparatus of any preceding claim, wherein the imageable region is a substantially two-dimensional cross-sectional slice.
- 10 10. The apparatus of any one of claims 1 through 8, wherein the imageable region is three-dimensional.
11. The apparatus of any one of claims 1-10, wherein the imageable region  
15 includes a region forward of the ultrasound probe.
12. The apparatus of any preceding claim, wherein the first guide body portion includes a polymeric material having a density in the range of 0.5 grams/cc to 3.5 grams/cc.
- 20 13. The apparatus of any preceding claim, wherein the first guide body portion includes polyethylene having a density in the range of about 0.8 grams/cc to about 1.1 grams/cc.
- 25 14. A guidewire in an intravascular ultrasound procedure, comprising:  
an elongate guide body configured to traverse a vascular vessel, the elongate guide body having at least a first guide body portion including an echolucent material; and  
at least one echogenic marker associated with the first guide body portion.
- 30 15. The guidewire of claim 14, wherein elongate guide body comprises at least two longitudinally-extending guide body portions joined to one another.

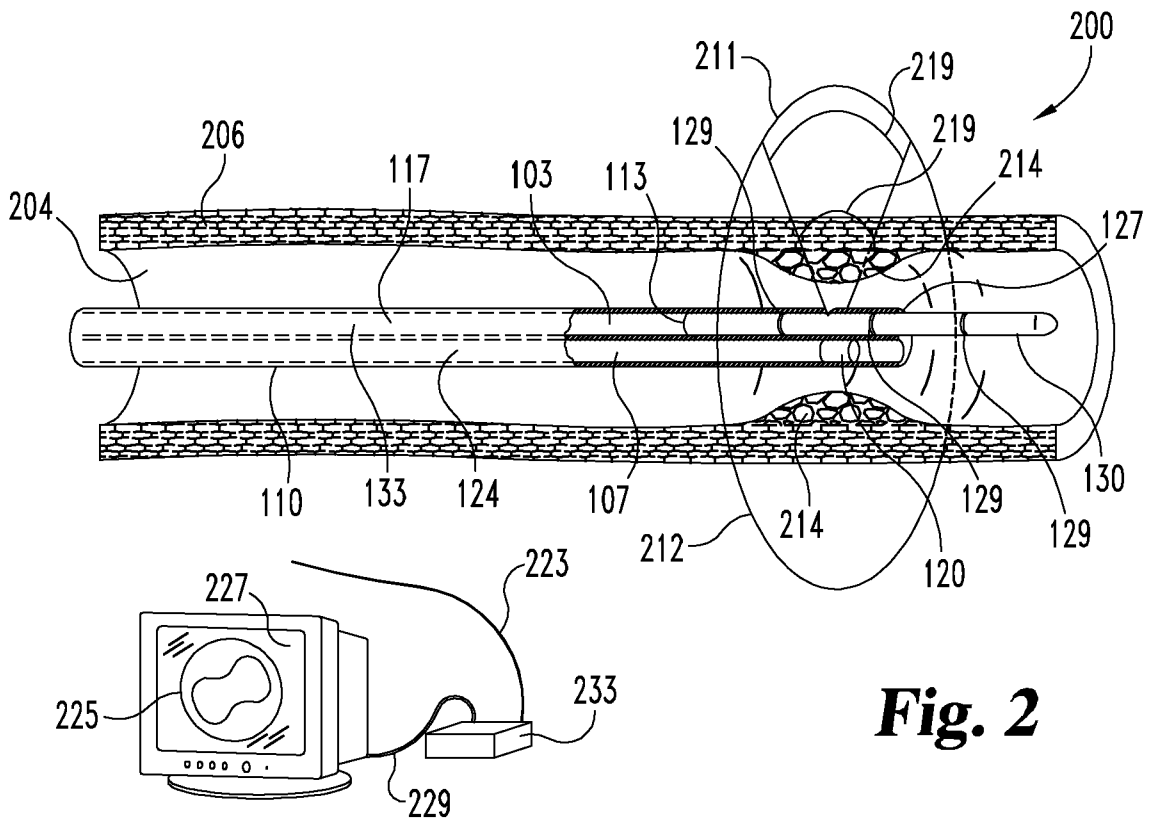
16. The guidewire of claims 14 or 15, further comprising:  
a second guide body portion formed of an echogenic material;  
wherein said elongate guide body includes at least said first guide body  
5 portion joined to said second guide body portion.
17. The guidewire of claims 15 or 16, wherein the first guide body portion  
includes a polymeric material, and the second guide body portion includes a metal.
- 10 18. The guidewire of any one of claims 14 through 17, wherein the at least one  
echogenic marker includes a plurality of longitudinally spaced echogenic marker  
regions.
- 15 19. The guidewire of any one of claims 14 through 17, wherein the at least one  
echogenic marker includes a plurality of discrete echogenic markers or a  
continuous longitudinally-extending echogenic marker.
- 20 20. The guidewire of claim 19, wherein the at least one echogenic maker  
includes said continuous longitudinally-extending echogenic marker, and wherein  
the longitudinally-extending echogenic marker defines a helical pattern.
21. The guidewire of any one of claims 14 through 20, wherein the first guide  
body portion includes a polymeric material having a density in the range of 0.5  
grams/cc to 3.5 grams/cc.
- 25 22. The guidewire of any one of claims 14 through 21, wherein the first guide  
body portion includes polyethylene having a density in the range of about 0.8  
grams/cc to about 1.1 grams/cc.

23. An intravascular procedure, comprising:  
introducing into a vascular vessel an elongate guide body having at least a first guide body portion including an echolucent material and having at least one echogenic marker associated with the first guide body portion; and  
5 imaging a region within the vascular vessel with an intravascular ultrasound probe, wherein during said imaging at least part of said first guide body portion is positioned in said region.
24. The method of claim 23, wherein said elongate guide body is comprised of  
10 at least two longitudinally-extending guide body portions joined to one another.
25. The method of claim 24, further comprising:  
a second said guide body portion formed of an echogenic material;  
wherein said elongate guide body includes said guide body portion joined  
15 to said second guide body portion.
26. The method of claim 24 or 25, wherein the first guide body portion includes a polymeric material, and the second guide body portion includes a metal.
- 20 27. The method of any one of claims 24 to 26, wherein the at least one echogenic marker includes a plurality of longitudinally spaced echogenic marker regions.
28. The method of any one of claims 24 to 26, wherein the at least one  
25 echogenic marker includes a plurality of discrete echogenic markers or a continuous longitudinally-extending echogenic marker.
29. The method of claim 28, wherein the at least one echogenic maker includes said continuous longitudinally-extending echogenic marker, and wherein the  
30 longitudinally-extending echogenic marker defines a helical pattern.

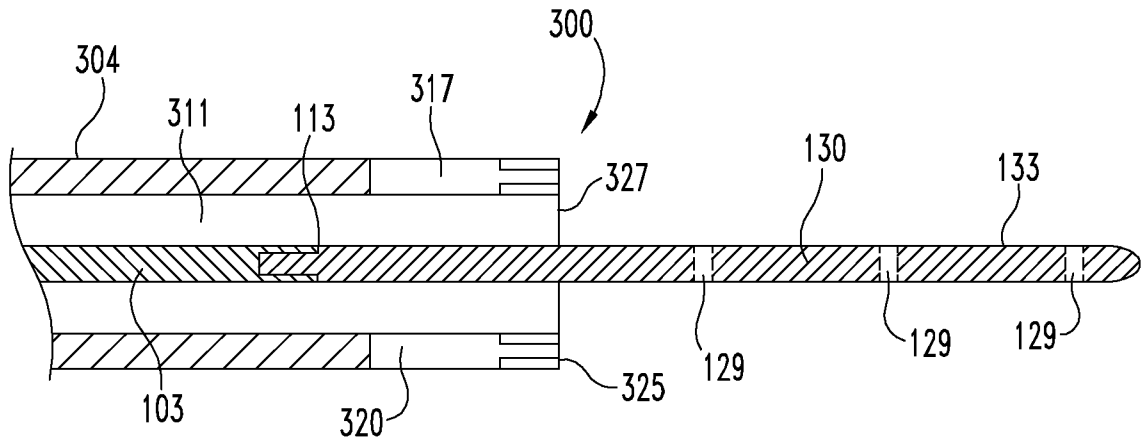
30. The method of any one of claims 24 to 29, wherein the first guide body portion includes a polymeric material having a density in the range of 0.5 grams/cc to 3.5 grams/cc.
- 5 31. The method of any one of claims 24 to 30, wherein the first guide body portion includes polyethylene having a density in the range of about 0.8 grams/cc to about 1.1 grams/cc.



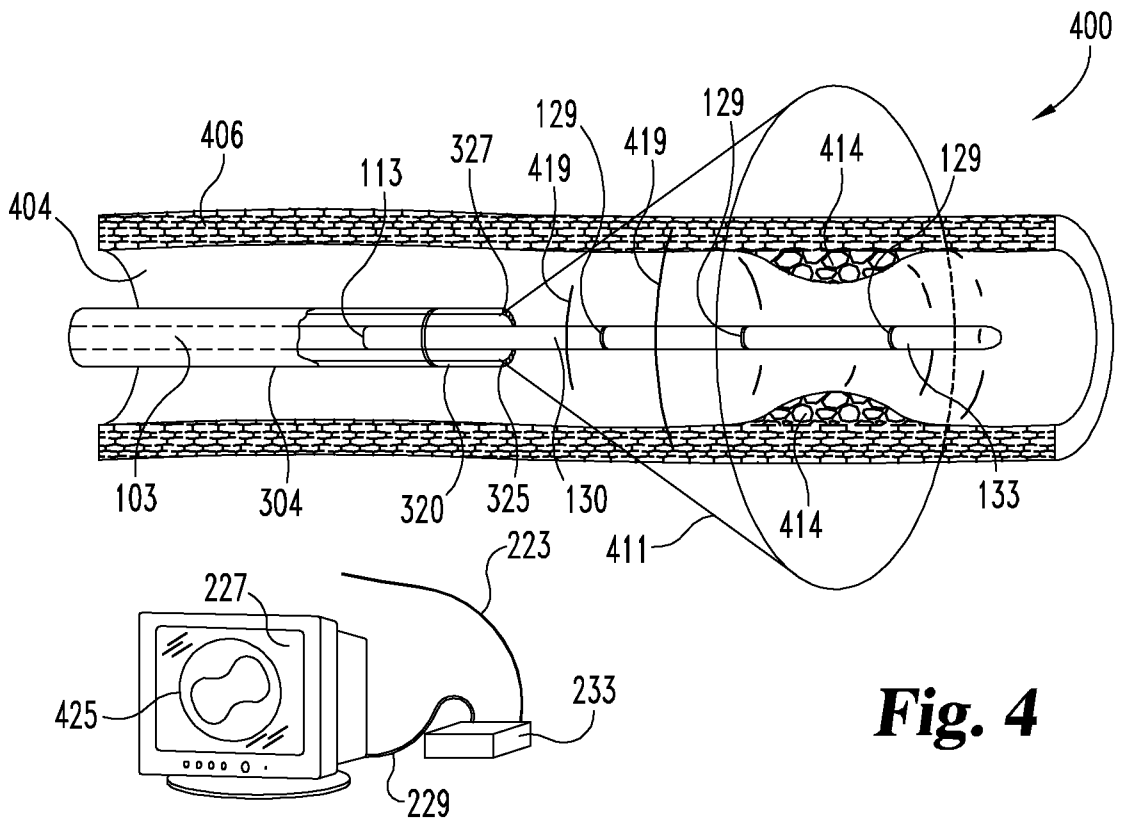
**Fig. 1**



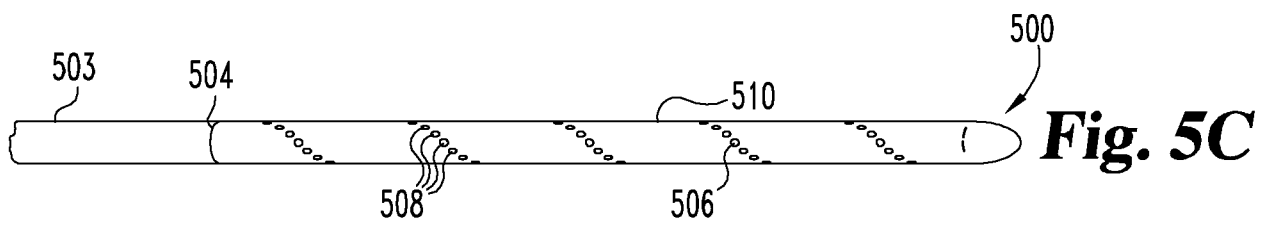
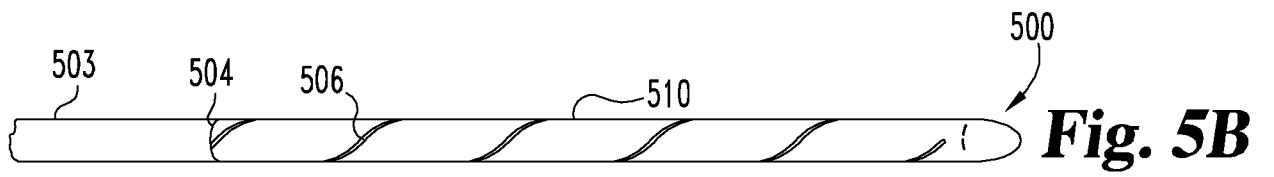
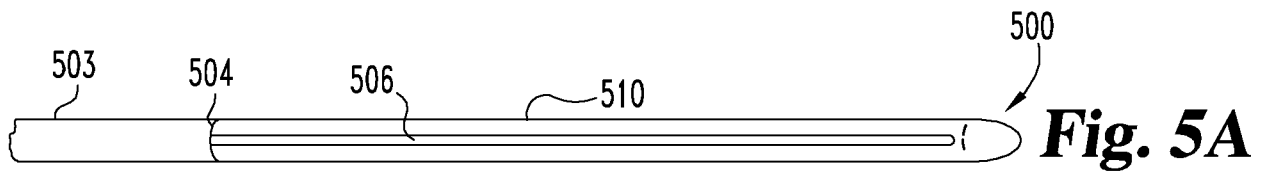
**Fig. 2**

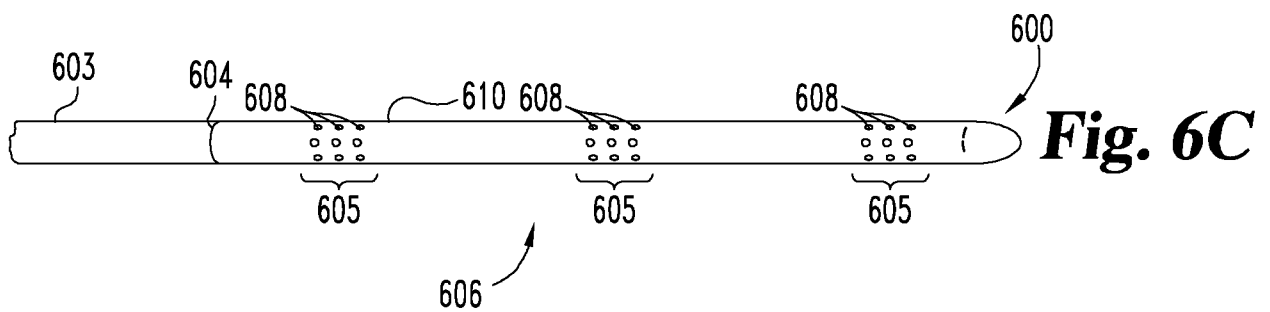
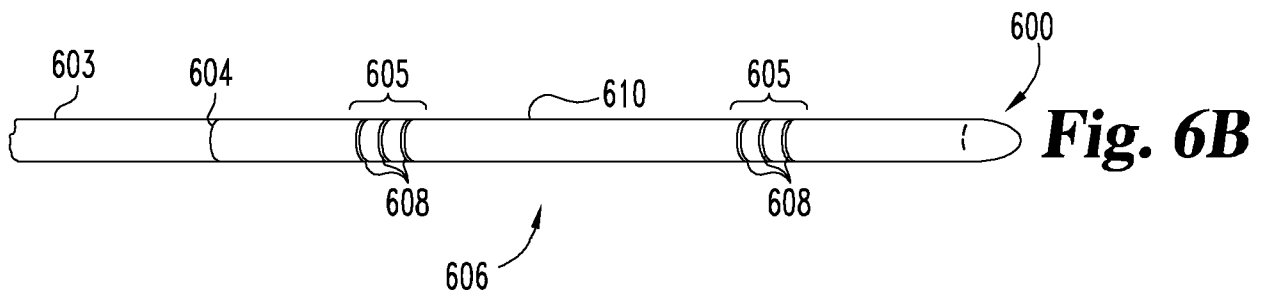
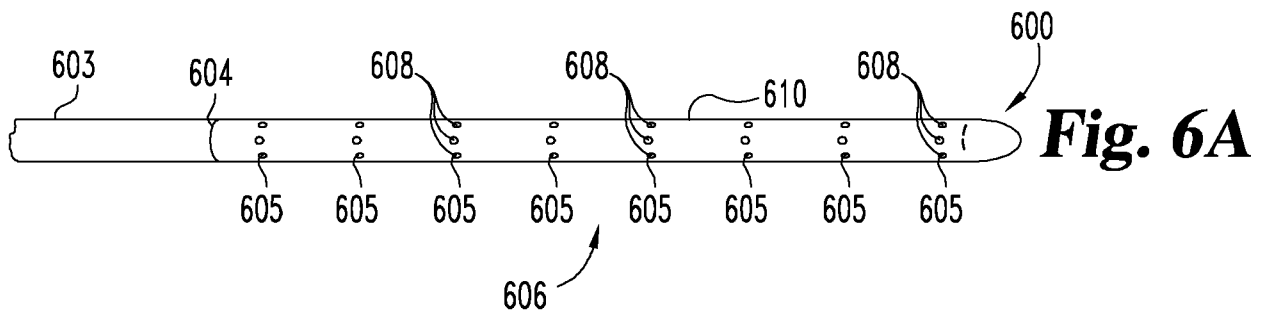


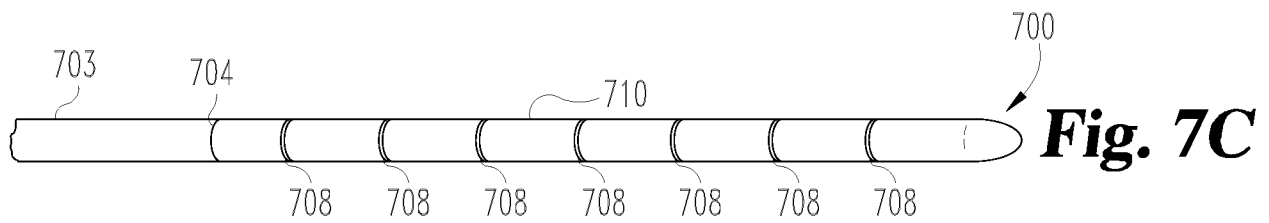
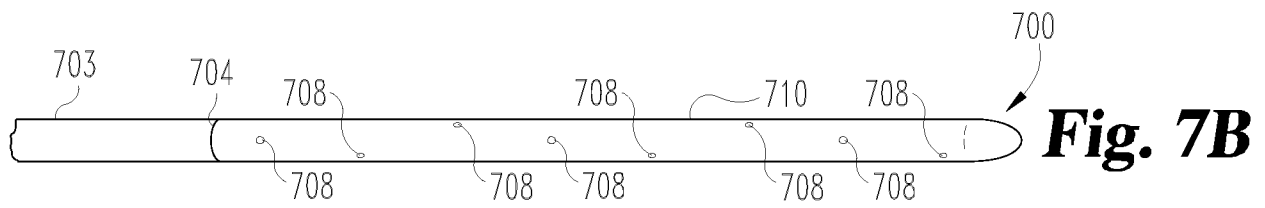
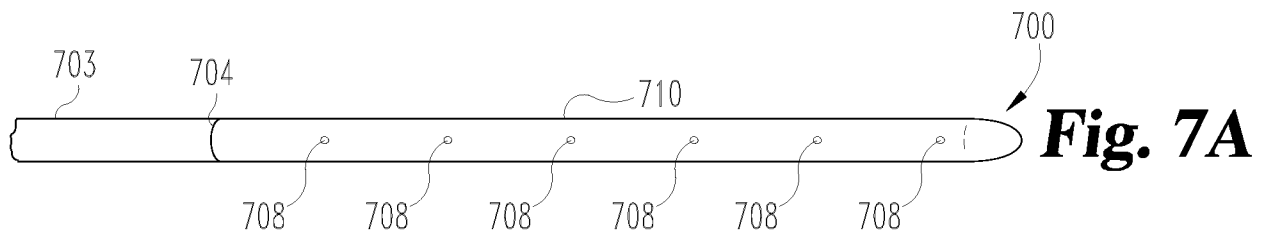
**Fig. 3**



**Fig. 4**







**A. CLASSIFICATION OF SUBJECT MATTER****A61B 8/08(2006.01)i, A61B 8/00(2006.01)i, A61B 8/14(2006.01)i**

According to International Patent Classification (IPC) or to both national classification and IPC

**B. FIELDS SEARCHED**

Minimum documentation searched (classification system followed by classification symbols)

A61B 8/08; B23K 11/00; A61M 31/00; A61B 18/00; A61M 25/00; A61B 8/14; A61B 6/00; A61B 17/00; A61B 18/12; A61B 8/00

Documentation searched other than minimum documentation to the extent that such documents are included in the fields searched

Korean utility models and applications for utility models

Japanese utility models and applications for utility models

Electronic data base consulted during the international search (name of data base and, where practicable, search terms used)

eKOMPASS(KIPO internal) &amp; keywords: intravascular, ultrasound probe, echogenic marker, guidewire

**C. DOCUMENTS CONSIDERED TO BE RELEVANT**

Category*	Citation of document, with indication, where appropriate, of the relevant passages	Relevant to claim No.
X	US 6475226 B1 (WILLIAM M. BELEF et al.) 05 November 2002 See abstract, column 23, line 60-column 25, line 27 and figures 22A-24B.	1, 14
Y		2-4, 15, 16
Y	US 2012-0228273 A1 (KATSURO MISHIMA et al.) 13 September 2012 See abstract, paragraphs [0028]-[0038] and figure 1.	2-4, 15, 16
A	JP 2008-119523 A (RITA MEDICAL SYSTEMS INC.) 29 May 2008 See abstract, paragraphs [0034]-[0110] and figures 1A-31.	1-4, 14-16
A	US 2011-0021924 A1 (SHRIRAM SETHURAMAN et al.) 27 January 2011 See abstract, paragraphs [0005],[0110]-[0117] and figure 12.	1-4, 14-16
A	US 2012-0095434 A1 (GREGORY W. FUNG et al.) 19 April 2012 See abstract, paragraphs [0005],[0006],[0087] and figures 1-2D.	1-4, 14-16

 Further documents are listed in the continuation of Box C. See patent family annex.

\* Special categories of cited documents:

"A" document defining the general state of the art which is not considered to be of particular relevance

"E" earlier application or patent but published on or after the international filing date

"L" document which may throw doubts on priority claim(s) or which is cited to establish the publication date of another citation or other special reason (as specified)

"O" document referring to an oral disclosure, use, exhibition or other means

"P" document published prior to the international filing date but later than the priority date claimed

"T" later document published after the international filing date or priority date and not in conflict with the application but cited to understand the principle or theory underlying the invention

"X" document of particular relevance; the claimed invention cannot be considered novel or cannot be considered to involve an inventive step when the document is taken alone

"Y" document of particular relevance; the claimed invention cannot be considered to involve an inventive step when the document is combined with one or more other such documents, such combination being obvious to a person skilled in the art

"&amp;" document member of the same patent family

Date of the actual completion of the international search

20 August 2015 (20.08.2015)

Date of mailing of the international search report

**21 August 2015 (21.08.2015)**

Name and mailing address of the ISA/KR

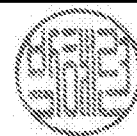
International Application Division  
Korean Intellectual Property Office  
189 Cheongsu-ro, Seo-gu, Daejeon Metropolitan City, 302-701,  
Republic of Korea

Facsimile No. +82-42-472-7140

Authorized officer

PARK, Hye Lyun

Telephone No. +82-42-481-3463



**Box No. II Observations where certain claims were found unsearchable (Continuation of item 2 of first sheet)**

This international search report has not been established in respect of certain claims under Article 17(2)(a) for the following reasons:

1.  Claims Nos.: 23-31  
because they relate to subject matter not required to be searched by this Authority, namely:  
Claims 23-31 pertain to a method for treatment of the human body by surgery or by therapy/diagnostic methods, and thus relate to a subject matter which this International Searching Authority is not required to search under PCT Article 17(2)(a)(i) and PCT Rule 39.1(iv).
2.  Claims Nos.: 7,20,29  
because they relate to parts of the international application that do not comply with the prescribed requirements to such an extent that no meaningful international search can be carried out, specifically:  
Claims 7,20,29 refer to claims 6,19,28 which do not comply with PCT Rule 6.4(a).
3.  Claims Nos.: 5,6,8-13,17-19,21,22,27,28,30,31  
because they are dependent claims and are not drafted in accordance with the second and third sentences of Rule 6.4(a).

**Box No. III Observations where unity of invention is lacking (Continuation of item 3 of first sheet)**

This International Searching Authority found multiple inventions in this international application, as follows:

1.  As all required additional search fees were timely paid by the applicant, this international search report covers all searchable claims.
2.  As all searchable claims could be searched without effort justifying an additional fees, this Authority did not invite payment of any additional fees.
3.  As only some of the required additional search fees were timely paid by the applicant, this international search report covers only those claims for which fees were paid, specifically claims Nos.:
  
4.  No required additional search fees were timely paid by the applicant. Consequently, this international search report is restricted to the invention first mentioned in the claims; it is covered by claims Nos.:

**Remark on Protest**

- The additional search fees were accompanied by the applicant's protest and, where applicable, the payment of a protest fee.
- The additional search fees were accompanied by the applicant's protest but the applicable protest fee was not paid within the time limit specified in the invitation.
- No protest accompanied the payment of additional search fees.

**INTERNATIONAL SEARCH REPORT**

Information on patent family members

International application No.

**PCT/US2015/029229**

Patent document cited in search report	Publication date	Patent family member(s)	Publication date
US 6475226 B1	05/11/2002	WO 00-45886 A2 WO 00-45886 A3	10/08/2000 23/11/2000
US 2012-0228273 A1	13/09/2012	AT 369176 T AT 422931 T CN 101537222 A CN 101537222 B DE 602004008019 T2 EP 1543857 A1 EP 1543857 B1 EP 1832308 A1 EP 1832308 B1 JP 2005-177094 A JP 2005-204677 A JP 2005-211511 A JP 4376048 B2 JP 4376073 B2 JP 4376078 B2 KR 10-1153506 B1 KR 10-1180518 B1 KR 10-1326997 B1 KR 10-1329394 B1 KR 10-2005-0062404 A KR 10-2011-0074727 A KR 10-2012-0039566 A KR 10-2013-0009710 A US 2005-0152731 A1 US 2010-0286663 A1 US 2012-0310218 A1 US 7785274 B2 US 8313445 B2 US 9033004 B2	15/08/2007 15/03/2009 23/09/2009 12/09/2012 24/04/2008 22/06/2005 08/08/2007 12/09/2007 18/02/2009 07/07/2005 04/08/2005 11/08/2005 02/12/2009 02/12/2009 02/12/2009 11/06/2012 06/09/2012 14/11/2013 14/11/2013 23/06/2005 01/07/2011 25/04/2012 23/01/2013 14/07/2005 11/11/2010 06/12/2012 31/08/2010 20/11/2012 19/05/2015
JP 2008-119523 A	29/05/2008	AU 2002-245243 B2 CA 2434151 A1 CA 2434151 C EP 1363700 A2 EP 1363700 A4 JP 2004-523272 A JP 4111829 B2 US 2002-0133148 A1 US 2004-0059328 A1 US 6622731 B2 US 7108696 B2 WO 02-054941 A2 WO 02-054941 A3 WO 02-054941 A9	22/03/2007 18/07/2002 22/12/2009 26/11/2003 09/11/2005 05/08/2004 02/07/2008 19/09/2002 25/03/2004 23/09/2003 19/09/2006 18/07/2002 18/09/2003 18/12/2003
US 2011-0021924 A1	27/01/2011	WO 2008-100386 A2	21/08/2008

**INTERNATIONAL SEARCH REPORT**

Information on patent family members

International application No.

**PCT/US2015/029229**

Patent document cited in search report	Publication date	Patent family member(s)	Publication date
		WO 2008-100386 A3	02/10/2008
US 2012-0095434 A1	19/04/2012	AU 2011-239637 A1	08/11/2012
		AU 2011-239637 B2	11/12/2014
		CA 2796347 A1	20/10/2011
		CN 103096963 A	08/05/2013
		EP 2558151 A1	20/02/2013
		JP 2013-523408 A	17/06/2013
		US 8986278 B2	24/03/2015
		WO 2011-130456 A1	20/10/2011

专利名称(译)	用于血管内超声程序的引导构件和相关装置		
公开(公告)号	<a href="#">EP3139839A1</a>	公开(公告)日	2017-03-15
申请号	EP2015789395	申请日	2015-05-05
[标]申请(专利权)人(译)	玛芬股份有限公司		
申请(专利权)人(译)	MUFFIN INCORPORATED		
当前申请(专利权)人(译)	MUFFIN INCORPORATED		
[标]发明人	FEARNOT NEAL E MCKINNIS PETER S HAWKINS KEM		
发明人	FEARNOT, NEAL E. MCKINNIS, PETER S. HAWKINS, KEM		
IPC分类号	A61B8/08 A61B8/00 A61B8/14		
CPC分类号	A61B8/0891 A61B8/12 A61B8/445 A61B8/483 A61M25/0108 A61M2025/09166 A61M25/09 A61M2025/0177 A61M2025/09133		
优先权	61/989679 2014-05-07 US		
其他公开文献	EP3139839A4		
外部链接	<a href="#">Espacenet</a>		

#### 摘要(译)

描述了具有至少一个回声段的导丝，以及相关的装置和方法。导丝可以与配备有血管内超声探头的装置组合，并且用于在血管环境中正在进行的手术期间有效地成像区域。回声段可以具有一个或多个回声标记，以使得能够使用血管内超声检测段的分段和/或相对运动。