



- (51) International Patent Classification:  
*A61B 8/00* (2006.01)
- (21) International Application Number:  
PCT/US2014/012274
- (22) International Filing Date:  
21 January 2014 (21.01.2014)
- (25) Filing Language: English
- (26) Publication Language: English
- (30) Priority Data:  
61/754,177 18 January 2013 (18.01.2013) US  
61/819,979 6 May 2013 (06.05.2013) US
- (71) Applicant: **THE JOHNS HOPKINS UNIVERSITY** [US/US]; 3400 N. Charles Street, Baltimore, MD 21218 (US).
- (72) Inventors: **O'BRIEN-COON, Devin**; 2210 E. Baltimore Street, Baltimore, MD 21231 (US). **HARFMAN, Kaitlyn**; 3900 N. Charles Street, Apt. 1113, Baltimore, MD 21218 (US). **LAI, Ting, Yu**; 3900 N. Charles Street,

Apt. 616, Baltimore, MD 21218 (US). **NARROW, David**; 101 W. 39th Street, Apt. C2, Baltimore, MD 21210 (US). **LIGHTMAN, Adam**; 101 W. 39th Street, Apt. C2, Baltimore, MD 21210 (US). **YOUSEPH, Yazdi**; 10328 Royal Ascot Court, Ellicott City, MD 21042 (US).

(74) Agent: **CHILDERS, Jeffrey, W.**; Ward And Smith, P.A., 1001 College Court, P.O. Box 867, New Bern, NC 28563 (US).

(81) Designated States (unless otherwise indicated, for every kind of national protection available): AE, AG, AL, AM, AO, AT, AU, AZ, BA, BB, BG, BH, BN, BR, BW, BY, BZ, CA, CH, CL, CN, CO, CR, CU, CZ, DE, DK, DM, DO, DZ, EC, EE, EG, ES, FI, GB, GD, GE, GH, GM, GT, HN, HR, HU, ID, IL, IN, IR, IS, JP, KE, KG, KN, KP, KR, KZ, LA, LC, LK, LR, LS, LT, LU, LY, MA, MD, ME, MG, MK, MN, MW, MX, MY, MZ, NA, NG, NI, NO, NZ, OM, PA, PE, PG, PH, PL, PT, QA, RO, RS, RU, RW, SA, SC, SD, SE, SG, SK, SL, SM, ST, SV, SY, TH, TJ, TM, TN, TR, TT, TZ, UA, UG, US, UZ, VC, VN, ZA, ZM, ZW.

[Continued on next page]

(54) Title: ULTRASOUND-DETECTABLE MARKERS, ULTRASOUND SYSTEM, AND METHODS FOR MONITORING VASCULAR FLOW AND PATENCY

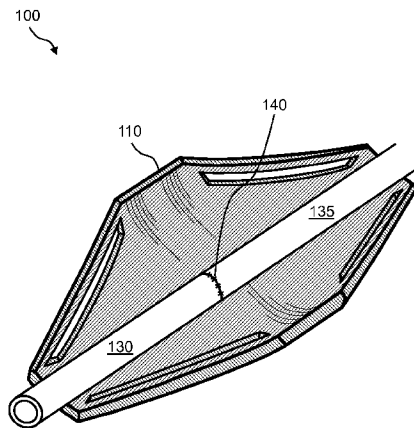

FIG. 6

(57) Abstract: An ultrasound-detectable marker, ultrasound system, and methods for monitoring vascular flow and patency are disclosed. The ultrasound-detectable marker comprises one or more resorbable polymers, one or more non-resorbable polymers, one or more non-polymeric materials, or any combinations thereof. The ultrasound-detectable marker is adapted for placement underneath, adjacent to, or above one or more vessels at a postoperative site, such as a vascular anastomosis site. Further, the ultrasound imaging system includes certain user guiding software and/or health analysis software for use with the ultrasound-detectable marker.





- (84) Designated States** (*unless otherwise indicated, for every kind of regional protection available*): ARIPO (BW, GH, GM, KE, LR, LS, MW, MZ, NA, RW, SD, SL, SZ, TZ, UG, ZM, ZW), Eurasian (AM, AZ, BY, KG, KZ, RU, TJ, TM), European (AL, AT, BE, BG, CH, CY, CZ, DE, DK, EE, ES, FI, FR, GB, GR, HR, HU, IE, IS, IT, LT, LU, LV, MC, MK, MT, NL, NO, PL, PT, RO, RS, SE, SI, SK, SM, TR), OAPI (BF, BJ, CF, CG, CI, CM, GA, GN, GQ, GW, KM, ML, MR, NE, SN, TD, TG).
- Published:**
- *with international search report (Art. 21(3))*
  - *before the expiration of the time limit for amending the claims and to be republished in the event of receipt of amendments (Rule 48.2(h))*

ULTRASOUND-DETECTABLE MARKERS, ULTRASOUND SYSTEM, AND  
METHODS FOR MONITORING VASCULAR FLOW AND PATENCY

CROSS-REFERENCE TO RELATED APPLICATIONS

5           This application claims the benefit of U.S. Provisional Application No.  
61/754,177, filed January 18, 2013, and U.S. Provisional Application No. 61/819,979,  
filed May 6, 2013, which are incorporated herein by reference in their entireties.

TECHNICAL FIELD

10           The presently disclosed subject matter relates generally to noninvasive methods of  
monitoring the health of a postoperative site, such as an anastomosis site, and more  
particularly to an ultrasound-detectable marker, ultrasound system, and methods for  
monitoring vascular flow and patency at postoperative sites.

15           BACKGROUND

It often is desirable to monitor vascular flow and/or patency at a postoperative  
site, such as an anastomosis site, following surgery. Noninvasive methods, such as  
ultrasound imaging, are, in principle, suitable for use in monitoring vascular flow and/or  
patency of anastomosis sites. Such monitoring, however, can be challenging because, for  
20           example, of (1) the difficulty in locating the postoperative site and (2) the difficulty in  
maintaining a linear orientation of the vessels of interest to obtain a useful image.

SUMMARY

25           In some aspects, the presently disclosed subject matter provides an ultrasound-  
detectable markers for monitoring postoperative site, such as a vascular anastomosis site,  
wherein the markers comprise one or more resorbable polymers, one or more non-  
resorbable polymers, one or more non-polymeric materials, or any combinations thereof;  
and wherein the markers are adapted for placement underneath, adjacent to, or above one  
or more vessels at a postoperative site, such as a vascular anastomosis site.

30           In other aspects, the presently disclosed subject matter provides a method for  
monitoring a postoperative site, the method comprising: (a) providing a marker

comprising one or more resorbable polymers, one or more non-resorbable polymers, one or more non-polymeric materials, or any combinations thereof, wherein the marker is adapted for placement underneath, adjacent to, or above one or more vessels at a postoperative site; (b) placing the marker underneath, adjacent to, or above at least one vessel during or after surgery; and (c) using a software algorithm to guide a user with an ultrasound probe to the location of the marker post-surgery.

In further aspects, the presently disclosed subject matter provides a method for orienting one or more vessels linearly in a plane during surgery, the method comprising: (a) providing a marker comprising one or more resorbable polymers, one or more non-resorbable polymers, one or more non-polymeric materials, or any combinations thereof, wherein the marker is adapted for placement underneath, adjacent to, or above one or more vessels at a postoperative site; (b) placing the marker in a subject during surgery; and (c) placing the one or more vessels on the marker; and wherein the one or more vessels are oriented linearly in a plane after being placed on the marker.

Certain aspects of the presently disclosed subject matter having been stated hereinabove, which are addressed in whole or in part by the presently disclosed subject matter, other aspects will become evident as the description proceeds when taken in connection with the accompanying Drawings as best described herein below.

## BRIEF DESCRIPTION OF THE DRAWINGS

Having thus described the presently disclosed subject matter in general terms, reference will now be made to the accompanying Drawings, which are not necessarily drawn to scale, and wherein:

FIG. 1 illustrates a perspective view of an example of the presently disclosed ultrasound-detectable marker, wherein the ultrasound-detectable marker includes slits;

FIG. 2 illustrates a plan view of the ultrasound-detectable marker including slits shown in FIG. 1;

FIG. 3A and FIG. 3B illustrate cross-sectional views of the ultrasound-detectable marker shown in FIG. 1;

FIG. 4 illustrates a perspective view of another example of the presently disclosed ultrasound-detectable marker, wherein the ultrasound-detectable marker includes eyelets;

FIG. 5 illustrates a perspective view of the presently disclosed ultrasound-detectable marker that further comprises a divider;

FIG. 6, FIG. 7, and FIG. 8 illustrate perspective views of examples of the presently disclosed ultrasound-detectable marker when in use;

5 FIG. 6 illustrates a perspective view of an end-to-end vascular anastomosis site oriented on a presently disclosed ultrasound-detectable marker;

FIG. 7 illustrates a perspective view of a side-to-side vascular anastomosis site oriented on a presently disclosed ultrasound-detectable marker;

10 FIG. 8 illustrates a perspective view of an end-to-side vascular anastomosis site oriented on a presently disclosed ultrasound-detectable marker;

FIG. 9 illustrates a block diagram of an example of an ultrasound imaging system that includes certain user guiding software and health analysis software for use with the ultrasound-detectable markers;

15 FIG. 10 is a representation depicting the tendency of postoperative vessels to naturally adopt a tortuous course, which is not amenable to cross-sectional visualization and imaging; and

FIG. 11 is a representation illustrating that the presently disclosed closed ultrasound-detectable marker can be used to align the vessels to permit visualization;

20 FIG. 12 illustrates a flow diagram of an example of a method of monitoring a vascular anastomosis site during surgery using the ultrasound-detectable marker and the ultrasound imaging system;

FIG. 13 illustrates a flow diagram of an example of a method of orienting at least one vessel linearly in a plane during surgery using the ultrasound-detectable marker and the ultrasound imaging system;

25 FIG. 14 illustrates a flow diagram of an example of the process flow of the user guiding algorithm of the ultrasound imaging system;

FIG. 15 illustrates a flow diagram of an example of the process flow of the health analysis algorithm of the ultrasound imaging system; and

30 FIG. 16, FIG. 17, FIG. 18, and FIG. 19 illustrate various views of yet other examples of the presently disclosed ultrasound-detectable marker.

## DETAILED DESCRIPTION

The presently disclosed subject matter now will be described more fully hereinafter with reference to the accompanying Drawings, in which some, but not all embodiments of the presently disclosed subject matter are shown. Like numbers refer to  
5 like elements throughout. The presently disclosed subject matter may be embodied in many different forms and should not be construed as limited to the embodiments set forth herein; rather, these embodiments are provided so that this disclosure will satisfy applicable legal requirements. Indeed, many modifications and other embodiments of the presently disclosed subject matter set forth herein will come to mind to one skilled in the  
10 art to which the presently disclosed subject matter pertains having the benefit of the teachings presented in the foregoing descriptions and the associated Drawings. Therefore, it is to be understood that the presently disclosed subject matter is not to be limited to the specific embodiments disclosed and that modifications and other embodiments are intended to be included within the scope of the appended claims.

15 In some embodiments, the presently disclosed subject matter provides an ultrasound-detectable marker, ultrasound system, and methods for monitoring vascular flow and patency. In particular embodiments, ultrasound-detectable markers are provided that can be placed at a postoperative site, such as a vascular anastomosis site, and located via ultrasound during or after surgery. The ultrasound-detectable markers  
20 provide a mechanism by which the postoperative site, such as a vascular anastomosis site, may be easily located and then the health of the postoperative site can be assessed. In other embodiments, an ultrasound imaging system is provided that includes certain user guiding software and/or health analysis software for use with the ultrasound-detectable marker, whereby the ultrasound imaging system and the ultrasound-detectable marker  
25 can be used for monitoring vascular flow and patency postoperatively.

As used herein, the term "vasculature" generally means any part of the circulatory system. More particularly, the term "vasculature" can include the arrangement of blood vessels in the body or in an organ or body part.

As used herein, the term "patency" means the state of being open, unobstructed,  
30 or unblocked, for example, a vein or artery that is free of obstruction.

## I. MARKERS FOR MONITORING VASCULAR FLOW AND PATENCY UNDER ULTRASOUND

Referring now to FIG. 1 and FIG. 2 is a perspective view and a plan view, respectively, of an example of the presently disclosed ultrasound-detectable marker **100**.

5 Further, FIG. 3A shows a cross-sectional view of the ultrasound-detectable marker **100** taken along line A-A of FIG. 1 and FIG. 3B shows a cross-sectional view of the ultrasound-detectable marker **100** taken along line B-B of FIG. 1.

The ultrasound-detectable marker **100** comprises a body **110** that is, for example, a plate having a substantially half-pipe or leaf shape (see FIG. 3B). In one example, the footprint of the ultrasound-detectable marker **100** is substantially octagonal, as shown in FIG. 1 and FIG. 2. However, the footprint of the ultrasound-detectable marker **100** is not limited to octagonal. The footprint of the ultrasound-detectable marker **100** can be any shape, including, but not limited to, ovular, circular, hexagonal, octagonal, square, rectangular, and the like.

15 The body **110** of the ultrasound-detectable marker **100** comprises, for example, one or more resorbable polymers. However, the ultrasound-detectable marker **100** is not limited to comprising resorbable polymers only. The body **110** of the ultrasound-detectable marker **100** can include non-polymeric materials, such as metal clips, or a combination of both resorbable polymers and non-polymeric materials.

20 As used herein, the term "resorbable" refers to a material, such as a polymeric material, which can be broken down and assimilated into a body. Representative resorbable polymers suitable for use with the presently disclosed markers include, but are not limited to, poly(lactic-co-glycolic acid) (PLGA), polylactides (PLAs), including poly(L-lactide), poly(D-lactide), and poly(DL-lactide), polyglycolide (PGA),  
25 polycaprolactone, L-lactide/DL-lactide copolymers, L-lactide/D-lactide copolymers, L-lactide/glycolide copolymers, L-lactide/caprolactone, DL-lactide/glycolide copolymers, and polyhydroxyalkanoates (PHAs), such as polyhydroxybutyrate (PHB), which include poly-3-hydroxybutyrate (P3HB), poly-4-hydroxybutyrate (P4HB), polyhydroxyvalerate (PHV), polyhydroxyhexanoate (PHH), polyhydroxyoctanoate (PHO), polydioxanone,  
30 hyaluronate, chitin, cellulose, collagen, polyethylene glycol, and copolymers thereof.

More particularly, in some embodiments, the presently disclosed marker comprises one or more resorbable polymers selected from the group consisting of PLA and PGA. In further embodiments, the one or more resorbable polymers is PLGA. In still further embodiments, the presently disclosed marker comprises two or more  
5 resorbable polymer layers, wherein at least two resorbable polymer layers do not comprise the same resorbable polymer. In other embodiments, the two resorbable polymer layers comprise PLA and PGA.

In some embodiments, the ultrasound-detectable marker **100** comprises a varying ratio of two or more resorbable polymers. In other embodiments, the ultrasound-  
10 detectable marker **100** comprises a varying ratio of PLA:PGA.

In some embodiments, the ultrasound-detectable marker **100** comprises two or more resorbable polymer layers and/or a varying ratio of two or more resorbable polymers, and the presence of two or more resorbable polymer layers and/or a varying ratio of two or more resorbable polymers creates an impedance change throughout the  
15 ultrasound-detectable marker **100**.

In still further embodiments of the presently disclosed ultrasound-detectable marker **100**, microbubbles can be introduced in the polymer to create impedance changes throughout the volume of the ultrasound-detectable marker **100**.

By "impedance changes throughout", it is meant that the majority of the  
20 ultrasound-detectable marker **100** has variations resulting in an impedance change. For example, more than about 50% to 100% of the ultrasound-detectable marker **100** has variations, such as more than 50%, 60%, 70%, 80%, 90%, or 99% of the ultrasound-detectable marker **100**. Variations in the ultrasound-detectable marker **100** can be made by manufacturing the ultrasound-detectable marker **100** in layers, by varying the ratios of  
25 at least two polymers in the ultrasound-detectable marker **100**, by adding microbubbles to the ultrasound-detectable marker **100**, and the like.

Such variations resulting in impedance changes allow the ultrasound-detectable marker **100** to be monitored using an ultrasound apparatus. Using the presently disclosed methods (see FIG. 12, FIG. 13, FIG. 14, FIG. 15), the site of a previous or ongoing  
30 surgery can be found easily and a vessel at the site of surgery can be imaged easily, such

as by ultrasound imaging. In addition, the specific site of a vascular anastomosis can be determined, monitored, and evaluated for the presence of patency or blood clotting.

In further embodiments, the ultrasound-detectable marker **100** comprises one or more non-resorbable polymers. In particular embodiments, the one or more non-  
5 resorbable polymers is selected from the group consisting of polycarbonate, polyetheretherketone (PEEK), polypropylene, silicone, polyethylene, and combinations thereof.

Referring again to FIG. 1 and FIG. 2, in some embodiments, the ultrasound-detectable marker **100** comprises one or more holes and/or slits **115** adapted to inform a  
10 geometric position. The holes or slits **115** can be cut through the volume of the ultrasound-detectable marker **100**. In the example shown in FIG. 1 and FIG. 2, four slits **115** are provided along four respective edges of the body **110**.

Adding holes and/or slits **115** in an asymmetric fashion to the ultrasound-detectable marker **100** aids the presently disclosed software algorithms (see FIG. 9) in  
15 determining the orientation of the ultrasound-detectable marker **100** *in vivo*. In other embodiments, eyelet holes can be added to the ultrasound-detectable marker **100** which can be used for attaching, e.g., by suturing, the ultrasound-detectable marker **100** to adjacent soft tissue. Accordingly, the ultrasound-detectable marker **100** comprises at least  
20 one eyelet hole adapted to secure the ultrasound-detectable marker **100** to soft tissue near the vascular anastomosis site. Namely, FIG. 4 shows another example of the ultrasound-detectable marker **100**, wherein the ultrasound-detectable marker **100** includes an eyelet **120** at each end of the body **110**, instead of the holes and/or slits **115**. However, in yet other embodiments, the ultrasound-detectable marker **100** can include both holes and/or  
slits **115** and eyelets **120**.

25 In some embodiments, the presently disclosed marker comprises a divider adapted to separate at least two blood vessels. Namely, FIG. 5 shows another example of the ultrasound-detectable marker **100**, wherein the ultrasound-detectable marker **100** includes a divider **125** protruding from a center portion of the body **110**. In further embodiments, the at least two blood vessels are an artery and a vein. In still further embodiments, the  
30 divider **125** ensures that the blood vessels are in parallel positions.

The ultrasound-detectable marker **100** can be scaled at a variety of sizes, which accommodate the variety of vessel sizes seen across different relevant medical applications. In representative embodiments, and referring again to FIG. 1, FIG. 2, FIG. 3A, and FIG. 3B, the ultrasound-detectable marker **100** has a length L, a width W, and a thickness T. Further, as shown in FIG. 3B, the substantially half-pipe or leaf shape of the body **110** has a depth D.

The length L of the ultrasound-detectable marker **100** can be, for example, from about 5 mm to about 80 mm. The width W of the ultrasound-detectable marker **100** can be, for example, from about 5 mm to about 60 mm. The thickness T of the ultrasound-detectable marker **100** can be, for example, from about 0.5 mm to about 8 mm. The depth D of the ultrasound-detectable marker **100** can be, for example, from about 5 mm to about 25 mm. In one example, the ultrasound-detectable marker **100** has a length L of about 40 mm, a width W of about 25 mm, a thickness T of about 2 mm, and a depth D of about 15 mm.

In some embodiments, the ultrasound-detectable marker **100** has a detectable *in vivo* lifetime during which the ultrasound-detectable marker **100** remains detectable by ultrasound. In other embodiments, the amount of time that the ultrasound-detectable marker **100** remains detectable depends on the type of material that the ultrasound-detectable marker **100** is constructed of, the thickness of the material, and the like. In further embodiments, the ultrasound-detectable marker **100** may remain detectable for days, weeks, months, or many years.

The ultrasound-detectable markers **100** shown in FIG. 1 through FIG. 5 are implantable resorbable polymeric markers that can be sutured to soft tissue via surgical sutures. These markers can be used to locate vessels of interest and to achieve the proper angle and slice of the vessel.

In certain surgeries, it is desirable to be able to monitor the site of surgery during the post-surgery healing period by a noninvasive method, such as ultrasound imaging. The ability to do so is particularly important for vascular surgeries. Examples of vascular surgeries include anastomoses, which are typically performed on blood vessels, such as arteries and veins.

As used herein, the term "anastomosis" refers to the joining together of two hollow structures, for example, two arteries or veins, to restore continuity after resection, e.g., a surgical procedure to remove part of an organ or a tumor or normal tissue around the margin of the tumor, or to bypass unresectable diseased tissue. Such procedures can  
5 be performed with suture material, mechanical staplers, or biodegradable or resorbable glues.

An anastomosis can be end-to-end, side-to-side, or end-to-side depending on the circumstances of the required reconstruction or bypass procedure. By way of example, FIG. 6, FIG. 7, and FIG. 8 illustrate perspective views of examples of the presently  
10 disclosed ultrasound-detectable marker **100** when in use. Namely, FIG. 6 shows an end-to-end anastomosis in relation to the ultrasound-detectable marker **100**, wherein the end of a first vessel **130** is joined to the end of a second vessel **135** and wherein a joint **140** is formed, for example, using sutures. FIG. 7 shows first vessel **130** joined end-to-end with second vessel **135**. Further, FIG. 7 shows a third vessel **150** is joined to the end of a  
15 fourth vessel **155**, wherein a joint **160** is formed, for example, using sutures. In this example, first vessel **130** and second vessel **135** are separated from and held parallel to third vessel **150** and fourth vessel **155** via the divider **125** of the ultrasound-detectable marker **100**. FIG. 8 shows an end-to-side anastomosis in relation to the ultrasound-detectable marker **100**, wherein the end of the first vessel **130** is joined to the side of the  
20 second vessel **135** and wherein the joint **140** is formed, for example, using sutures.

Further, the term "reanastomosis" refers to a surgical reconnection, for example, to reverse a prior surgery to disconnect an anatomical anastomosis, e.g., tubal reversal after tubal ligation, or to reverse a vasectomy. The term "anastomosis" as used herein includes "reanastomosis."  
25

Most vascular procedures, including, but not limited to, arterial bypass operations, e.g., a coronary artery bypass, aneurysmectomies, and solid organ transplants, require vascular anastomoses. In other examples, an anastomosis connecting an artery to a vein also is used to create an arteriovenous fistula, e.g., a cimino fistula, as an access for hemodialysis in patients having end stage renal failure.  
30

Further, resections of gastrointestinal organs, including the esophagus, stomach, small bowel, large bowel, bile ducts, and pancreas, are followed by anastomoses to

restore continuity. Such resections include bypass operations of the GI tract during bariatric surgery.

In yet further examples, surgical procedures, such as radical prostatectomy and radical cystectomy, involving the urinary tract, including ureters, urinary bladder, and urethra, can require anastomosis of the bladder to the urethra to restore continuity.

The presently disclosed ultrasound-detectable marker **100** and methods of use thereof localize postoperative vessels under ultrasound; provide feedback to the user regarding the location of these vessels; provide imagery of vasculature to determine patency; and provide quantitative analysis of vascular flow to monitor vascular health.

Further, the geometry of the presently disclosed ultrasound-detectable marker **100** provides multi-axis feedback to guide the user to the desired probe orientation and view (i.e., both translational and rotational movements of the probe).

In some embodiments, the presently disclosed ultrasound-detectable marker **100** provides an implantable, resorbable marker for monitoring blood vessels after or during post-surgical reconstruction. The ultrasound-detectable marker **100** serves as an indicator, which provides echogenic contrast when viewed under ultrasound, thus allowing medical personnel, e.g., an ultrasound technician, nurse, or doctor, to effectively and accurately locate the anastomosis site. In addition, the presently disclosed ultrasound-detectable marker **100** aids in maintaining a linear orientation of the vessel(s) so that the vessel(s) can be imaged. If the vessel is not traveling linearly in a plane, such as if it is coiled in an "S" shape, for example, the vessel will not be able to be clearly imaged, such as by ultrasound imaging.

## II. SYSTEM FOR MONITORING VASCULAR FLOW AND PATENCY UNDER ULTRASOUND

In other embodiments, the presently disclosed subject matter includes software as described herein below with reference to FIG. 9, which provides images and quantitative analysis of the vasculature to determine patency and volumetric flow rate, thus indicating the overall health of the tissue site.

Accordingly, the presently disclosed subject matter provides an ultrasound-detectable marker **100** for monitoring a postoperative site, such as a vascular anastomosis

site, wherein the ultrasound-detectable marker **100** comprises one or more resorbable polymers, one or more non-resorbable polymers, one or more non-polymeric materials, or any combinations thereof; and wherein the marker is adapted for placement underneath, adjacent to, or above one or more vessels at the postoperative site.

5           FIG. 9 is a block diagram illustrating an ultrasound imaging system **900** that includes certain user guiding software and health analysis software for use with the ultrasound-detectable markers **100**. It will be understood by those having ordinary skill in the art that the ultrasound imaging system **900**, as illustrated in FIG. 9, and the operation thereof as described below, is intended to be generally representative of such  
10           systems and that any particular system may differ significantly from that shown in FIG. 9. The ultrasound imaging system **900** includes a transmit beamformer **910** coupled through a transmit receive (T/R) switch **912** to an ultrasound probe **920**. While the ultrasound probe **920** may be any transducer probe, in one example, the ultrasound probe **920** is a matrix transducer probe.

15           In one example, the T/R switch **912** includes one switch element for each transducer element. In another example, the ultrasound probe **920** includes multiplexing circuitry, or the like, to reduce the number of required switches. The transmit beamformer **910** receives pulsed sequences from a pulse generator **916**. The ultrasound probe **920**, energized by the transmit beamformer **910**, transmits ultrasound energy into a  
20           region of interest in a patient's body and receives reflected ultrasound energy, commonly referred to as echoes, from various structures and organs within the body. As is known by those having ordinary skill in the art, by appropriately delaying the waveforms applied to each transducer element by the transmit beamformer **910**, a focused ultrasound beam may be transmitted from the ultrasound probe **920**.

25           The ultrasound probe **920** is also coupled, through the T/R switch **912**, to a receive beamformer **918**. Ultrasound energy from a given point within the patient's body is received by the transducer elements at different times. The transducer elements convert the received ultrasound energy to transducer signals which may be amplified, individually delayed and then summed by the receive beamformer **918** to provide a  
30           beamformed signal that represents the received ultrasound levels along a desired receive line ("beam"). The receive beamformer **918** may be a digital beamformer including an

analog-to-digital converter for converting the transducer signals to digital values, or may be an analog beamformer. As known to those having ordinary skill in the art, the delays applied to the transducer signals may be varied during reception of ultrasound energy to effect dynamic focusing. The process is repeated for multiple scan lines to create a frame  
5 of data for generating an image of the region of interest in the patient's body.

The receive beamformed signals are then applied to a signal processor **924**, which processes the beamformed signal for improved image quality. The receive beamformer **918** and the signal processor **924** comprise an ultrasound receiver **926**. The output of the signal processor **924** is supplied to a scan converter **928**, which converts sector scan and  
10 other scan pattern signals to conventional raster scan display formats. The output of the scan converter **928** is supplied to a display **930**, which displays an image of the region of interest in the patient's body.

A system controller **932** provides overall control of the ultrasound imaging system **900**. The system controller **932** performs timing and control functions and  
15 typically includes a microprocessor operating under the control of graphics generator **936** and control routines **942**, both contained within data storage **940**. When the desired ultrasound image is communicated to the system controller **932**, the system controller **932**, in cooperation with the control routines **942** and the graphics generator **936**, determines the appropriate scan lines that should be projected by the ultrasound probe  
20 **920** to achieve the desired ultrasound image communicated to the system controller **932** and displayed at display **930**.

The control routines **942** can include standard routines that are typically found in ultrasound systems, such as, but not limited to, spectral Doppler image processing **944**, color Doppler image processing **946**, and two-dimensional (2D) image processing **948**.  
25 However, in the ultrasound imaging system **900**, the control routines **942** further include a user guiding algorithm **950** and a health analysis algorithm **952** for use with the ultrasound-detectable marker **100**.

Namely, the user guiding algorithm **950** is used during surgery when the ultrasound-detectable marker **100** is placed in the patient. Further, the user guiding  
30 algorithm **950** is used postoperatively to guide the user to locate the vascular anastomosis site or the postoperative site (i.e., locate the ultrasound-detectable marker **100**) for

monitoring vascular flow and patency. More details of the user guiding algorithm **950** are described herein below with reference to FIG. 14. The health analysis algorithm **952** is used to measure and display flow data from at least one vessel. More details of the health analysis algorithm **952** are described herein below with reference to FIG. 15.

5 Accordingly, using the user guiding algorithm **950** and the health analysis algorithm **952**, the ultrasound imaging system **900** provides images and quantitative analysis of the vasculature to determine patency and volumetric flow rate, thus indicating the overall health of the tissue site.

### 10 III. METHODS OF MONITORING VASCULAR FLOW AND PATENCY UNDER ULTRASOUND

The design of the presently disclosed ultrasound-detectable marker **100** provides feedback to the user to help orient an ultrasound probe properly via a specific ultrasound signature. In one embodiment, the ultrasound-detectable marker **100** is placed  
15 underneath a vessel at the site of anastomosis in a reconstructive surgical procedure that involves joining two vessels, such as shown in FIG. 6, FIG. 7, and FIG. 8. Placement of the ultrasound-detectable marker **100** can be accomplished by suturing the ultrasound-detectable marker **100** to soft tissue adjacent to the vessel, by using an adhesive, or by a hooking mechanism. In embodiments involving suturing, holes and/or slits (e.g., holes  
20 and/or slits **115** shown in FIG. 1 and FIG. 2) or small eyelets (e.g., eyelets **120** shown in FIG. 4) can be provided in the ultrasound-detectable marker **100**. In other embodiments, the ultrasound-detectable marker **100** is placed adjacent to the one or more vessels or above one or more vessels.

The presently disclosed ultrasound-detectable marker **100** can be used post-  
25 operatively during an ultrasound exam to guide the positioning of the probe (e.g., ultrasound probe **920**) until the postoperative site, such as an anastomosis site, is found. This navigation process can be performed using the geometric marker feedback independently, or it can be performed with the aid of software; namely, the user guiding algorithm **950** and/or the health analysis algorithm **952**. At this point, the medical  
30 personnel operating the ultrasound (e.g., ultrasound imaging system **900**) is able to capture images of the vessels both axially and longitudinally, in addition to gathering

vessel parameters, including vessel lumen patency and blood flow rate, using the color Doppler function (e.g., color Doppler image processing **946**) inherent in ultrasound machines known in the art.

In reconstructive surgery applications, such as microvascular reconstruction or "free flap" surgery, this information allows for accurate examination of vessel function postoperatively to assess the overall health of the reconstructed tissue and indicate whether clinical actions should be taken. While many methods of solving the problem of monitoring the reconstructed tissue's health have been tried, none permit the direct visualization of flow and all suffer from drawbacks that have prevented any single technology from gaining predominant use (see Smit JM, Zeebregts CJ, Acosta R, Werker PM. Advancements in free flap monitoring in the last decade: a critical review. *Plast Reconstr Surg.* Jan 2010;125(1):177-185). More particularly, the presently disclosed ultrasound-detectable marker **100** and methods may allow detection of clots upon formation well before complete occlusion occurs. Both clinical examination and existing technologies frequently only detect complete vessel blockage, by which time it may be too late to restore blood flow and salvage the surgery (see Gimbel ML, Rollins MD, Fukaya E, Hopf HW. Monitoring partial and full venous outflow compromise in a rabbit skin flap model. *Plast Reconstr Surg.* Sep 2009;124(3):796-803). The presently disclosed ultrasound-detectable marker **100** and methods also can be useful in transplant and vascular surgeries, as well as in procedures involving urology.

Representative examples illustrating the use of the presently disclosed ultrasound-detectable marker **100** are provided in FIGS. 10 and 11. Referring now to FIG. 10, is shown an vascular anastomosis site **1000** in which a pair of postoperative vessels **1010** can naturally adopt a tortuous course, which is not amenable to cross-sectional visualization and imaging. In contrast, referring now to FIG. 11, the presently disclosed ultrasound-detectable marker **100** aligns the postoperative vessels **1010** to permit visualization, as shown in *in vivo* swine ultrasound images where an artery and vein are easily observed inside the echogenic marker, e.g., the presently disclosed ultrasound-detectable marker **100** (e.g., see inset showing a frame **1020** of an ultrasound image).

Accordingly, in some embodiments, the presently disclosed subject matter provides a method for monitoring a vascular anastomosis site. In particular

embodiments, the methods are used to monitor a vascular anastomosis site after surgery. For example, FIG. 12 illustrates a flow diagram of an example of a method **1200** of monitoring a vascular anastomosis site during surgery or post-surgery using the ultrasound-detectable marker **100** and the ultrasound imaging system **900**. The method  
5 **1200** includes, but is not limited to, the following steps.

At a step **1210**, the ultrasound-detectable marker **100** that comprises one or more resorbable polymers is provided, wherein the ultrasound-detectable marker **100** is adapted for placement underneath, adjacent to, or above one or more vessels at a vascular anastomosis site.

10 At a step **1215**, the ultrasound-detectable marker **100** is placed underneath, adjacent to, or above at least one vessel during or after surgery.

At a step **1220**, the user guiding algorithm **950** is used postoperatively to guide a user with an ultrasound probe to the location of the ultrasound-detectable marker **100**.

In yet other embodiments, the presently disclosed subject matter provides a  
15 method for orienting at least one vessel linearly in a plane during surgery. For example, FIG. 13 illustrates a flow diagram of an example of a method **1300** of orienting at least one vessel linearly in a plane during surgery using the ultrasound-detectable marker **100** and the ultrasound imaging system **900**. The method **1300** includes, but is not limited to, the following steps.

20 At a step **1310**, the ultrasound-detectable marker **100** that comprises one or more resorbable polymers is provided, wherein the ultrasound-detectable marker **100** is adapted for placement underneath, adjacent to, or above one or more vessels at a vascular anastomosis site.

At a step **1315**, the ultrasound-detectable marker **100** is placed in a subject during  
25 surgery. Namely, the ultrasound-detectable marker **100** is placed underneath, adjacent to, or above at least one vessel during surgery.

At a step **1320**, the one or more vessels are placed on the ultrasound-detectable marker **100**, wherein the one or more vessels are oriented linearly in a plane after being placed on the ultrasound-detectable marker **100**.

30 In other embodiments, the methods further comprise using the user guiding algorithm **950** of the ultrasound imaging system **900** of FIG. 9 to guide the user with

respect to locating the ultrasound-detectable marker **100** via ultrasound. For example, FIG. 14 illustrates a flow diagram of an example of the process flow **1400** of the user guiding algorithm **950** of the ultrasound imaging system **900**. The process flow **1400** includes, but is not limited to, the following steps.

5           At a step **1410**, ultrasound waves are generated via, for example, the pulse generator **916**, the transmit beamformer **910**, the T/R switch **912**, and the ultrasound probe **920**.

          At a step **1415**, the reflected ultrasound waves are received with a transducer; namely, via the ultrasound probe **920** and the ultrasound receiver **926**.

10           At a step **1420**, using, for example, the signal processor **924** and the system controller **932**, at least one B-mode image is generated. As used herein, the term "B-mode" refers to a two-dimensional cross section of the tissue being imaged. More particularly, the term "B-mode" refers to a two-dimensional ultrasound presentation of echo-producing interfaces in a single plane.

15           At a step **1425**, using, for example, the signal processor **924** and the system controller **932**, the at least one B-mode image is segmented. As used herein, the term "segmented" refers to the process of partitioning a digital image into multiple segments, e.g., sets of pixels. Such image segmentation can be used to simplify and/or change the representation of an image and is typically used to locate objects and boundaries, e.g.,  
20           lines, curves, and the like, in images. More particularly, image segmentation is the process of assigning a label to every pixel in an image such that pixels having the same label share certain visual characteristics. The end result of image segmentation is a set of segments that collectively cover the entire image, or a set of contours extracted from the image.

25           At a step **1430**, using, for example, the system controller **932** and/or the user guiding algorithm **950**, a template is matched to the defined marker shape. As used herein, the process of "template matching," as in when a template is matched to the defined marker shape, refers to a technique in digital image processing for finding small parts of an image that match a template image, for example, as a way to detect edges in  
30           an image. If the template image has strong features, a feature-based approach can be used. For templates that do not have strong features, or under circumstances when the

bulk of the template image constitutes the matching image, a template-based approach can be used. In instances when the template might not provide a direct match, eigenspaces, e.g., templates that detail the matching object under a number of different conditions including, but not limited to, varying perspectives, illuminations, color  
5 contrasts, or acceptable matching poses, can be used. In some embodiments, the process of template matching uses a convolution mask, i.e., a template, tailored to a special feature of the search image to be detected.

For example, in representative embodiments, such a method can be implemented by first choosing a part of the search image to use as a template, which can be referred to  
10 as the search image  $S(x, y)$ , where  $(x, y)$  represent the coordinates of each pixel in the search image. The template can be represented as  $T(x_t, y_t)$ , where  $(x_t, y_t)$  represents the coordinates of each pixel in the template. The center (or the origin) of template  $T(x_t, y_t)$  can then be moved over each  $(x, y)$  point in the search image and the sum of products can be calculated between the coefficients in  $S(x, y)$  and  $T(x_t, y_t)$  over the whole area  
15 spanned by the template. As all possible positions of the template with respect to the search image are considered, the position with the highest score is the best position.

At a step 1435, using, for example, the system controller 932 and/or the user guiding algorithm 950, a pose is estimated. By "pose," is meant the combination of position and orientation of an object. The pose of an object is generally determined using  
20 image data. In some embodiments, the pose is described by means of a rotation and translation transformation, which brings the object from a reference pose to the observed pose. The pose estimation is performed to determine how the transducer and marker are positioned relative to each other. For example, the pose estimation may determine that the transducer is currently seeing a rotated view of the marker.

At a step 1440, using, for example, the system controller 932 and/or the user guiding algorithm 950, a desired pose is calculated. The "desired pose" is the relative positioning of marker and transducer that one wishes to achieve. This position could be either the very center of the marker (i.e., no translation or rotation), or it could simply be that the desired pose is the same transducer/marker relation at which earlier flow  
25 measurements were taken and it is desirable to take new measurements at exactly the  
30 same view on the ultrasound.

At a step **1445**, using, for example, the system controller **932** and/or the user guiding algorithm **950**, guidance is provided to the user with respect to repositioning the ultrasound probe **920** based on the desired pose. Guidance can be provided by either a display of the marker shape on which the cross-sectional view that the ultrasound is currently observing is labeled or highlighted or by stepwise corrective instructions to achieve the desired pose (e.g., rotate the transducer 30 degrees clockwise, move one cm forward, and the like).

In still other embodiments of the process flow **1400**, more than one B-mode image is generated and segmented before matching a template to the defined marker shape. In further embodiments, the process flow **1400** can be repeated until the ultrasound probe **920** is positioned so that the desired pose is observed.

In some embodiments, the methods further comprise using the health analysis algorithm **952** of the ultrasound imaging system **900** to measure and display flow data from at least one vessel. For example, FIG. 15 illustrates a flow diagram of an example of the process flow **1500** of the health analysis algorithm **952** of the ultrasound imaging system **900**. The process flow **1500** includes, but is not limited to, the following steps.

At a step **1510**, ultrasound waves are generated via, for example, the pulse generator **916**, the transmit beamformer **910**, the T/R switch **912**, and the ultrasound probe **920**.

At a step **1515**, the reflected ultrasound waves are received with a transducer; namely, via the ultrasound probe **920** and the ultrasound receiver **926**.

At a step **1520**, using, for example, the system controller **932** and/or the health analysis algorithm **952**, the desired pose may optionally be confirmed. This step is optional. Pose estimation (as per above) can be performed again to confirm that the position is as desired prior to beginning doppler data collection. For example, if the user was guided to the center of the marker by the guidance algorithm, but then moved the probe prior to starting collection of the flow data, inaccurate data could be obtained. Performing one more pose estimation as part of the Doppler flow data collection process allows confirmation of pose, as well as recording of the location (pose) at which the data were collected.

At a step **1525**, using, for example, the system controller **932** and/or the health analysis algorithm **952**, at least one B-mode image and at least one set of Doppler velocities are collected via, for example, spectral Doppler image processing **944** and color Doppler image processing **946**.

5 At a step **1530**, using, for example, the system controller **932** and/or the health analysis algorithm **952**, a power signal is spatially analyzed to define the X/Y boundaries of the at least one blood vessel.

At a step **1535**, using, for example, the system controller **932** and/or the health analysis algorithm **952**, multiple frames are temporally analyzed to differentiate the at  
10 least one vessel from another vessel.

At a step **1540**, using, for example, the system controller **932** and/or the health analysis algorithm **952**, individual Doppler velocities are integrated over the calculated X/Y boundaries of the at least one vessel.

At a step **1545**, using, for example, the system controller **932** and/or the health  
15 analysis algorithm **952**, the multiple frames are averaged.

At a step **1550**, the integrated, averaged Doppler velocities are quantitatively displayed to the user via display **930** or otherwise indicated to the user.

Referring now to FIG. 16, FIG. 17, FIG. 18, and FIG. 19 are various views of yet other examples of the presently disclosed ultrasound-detectable markers. Namely, FIG.  
20 16 shows various perspective views of an ultrasound-detectable marker **1600**. The body of the ultrasound-detectable marker **1600** comprises a pair of ridges **1610**, which flank a trough **1615**. This arrangement provides a channel in which one or more vessels may rest. The body of the ultrasound-detectable marker **1600** also comprises holes and/or slits  
25 **1620**. In this example, the overall footprint of the ultrasound-detectable marker **1600** has a taper from one end to the other. In other words, one end of the ultrasound-detectable marker **1600** is narrower than the other end, as shown.

FIG. 17 shows various perspective views of an ultrasound-detectable marker  
**1700**. The body of the ultrasound-detectable marker **1700** comprises a pair of ridges  
**1710**, which flank a trough **1715**. This arrangement provides a channel in which one or  
30 more vessels may rest. The body of the ultrasound-detectable marker **1700** also comprises a hole and/or slit **1720**. In this example, the overall footprint of the

ultrasound-detectable marker **1700** has an hourglass-type of shape. In other words, the middle region of the ultrasound-detectable marker **1700** is narrower than the end regions, as shown.

FIG. 18 shows various perspective views of an ultrasound-detectable marker **1800**. The body of the ultrasound-detectable marker **1800** comprises a pair of plateaus **1810**, which flank a trough **1815**. This arrangement provides a channel in which one or more vessels may rest. The body of the ultrasound-detectable marker **1800** also comprises holes and/or slits **1820**. In this example, the ultrasound-detectable marker **1800** has a rectangular table-like structure, as shown.

FIG. 19 shows a perspective view of an ultrasound-detectable marker **1900**. The body of the ultrasound-detectable marker **1900** comprises a pair of plateaus **1910**, which flank a trough **1915**. This arrangement provides a channel in which one or more vessels may rest. The body of the ultrasound-detectable marker **1900** also comprises holes and/or slits **1920**. In this example, the ultrasound-detectable marker **1900** has a rectangular plate-like structure, as shown.

As described with reference to the ultrasound-detectable markers **100** shown in FIG. 1 through FIG. 8, the ultrasound-detectable markers **1600**, **1700**, **1800**, **1900** comprise one or more resorbable polymers, one or more non-resorbable polymers, one or more non-polymeric materials, or any combinations thereof.

In other embodiments, the presently disclosed methods comprise determining a patency and/or a vascular health of at least one vessel. In further embodiments, determining a patency and/or a vascular health of at least one vessel comprises detecting a blood clot before complete occlusion occurs.

The subject treated by the presently disclosed methods in their many embodiments is desirably a human subject, although it is to be understood that the methods described herein are effective with respect to all vertebrate species, which are intended to be included in the term "subject."

A "subject" can include a human subject for medical purposes, such as for the treatment of an existing condition or disease or the prophylactic treatment for preventing the onset of a condition or disease, or an animal subject for medical, veterinary purposes, or developmental purposes. Suitable animal subjects include mammals including, but not

limited to, primates, e.g., humans, monkeys, apes, and the like; bovines, e.g., cattle, oxen, and the like; ovines, e.g., sheep and the like; caprines, e.g., goats and the like; porcines, e.g., pigs, hogs, and the like; equines, e.g., horses, donkeys, zebras, and the like; felines, including wild and domestic cats; canines, including dogs; lagomorphs, including rabbits, hares, and the like; and rodents, including mice, rats, and the like. An animal may be a transgenic animal. In some embodiments, the subject is a human including, but not limited to, fetal, neonatal, infant, juvenile, and adult subjects. Further, a "subject" can include a patient afflicted with or suspected of being afflicted with a condition or disease. Thus, the terms "subject" and "patient" are used interchangeably herein.

10

Following long-standing patent law convention, the terms "a," "an," and "the" refer to "one or more" when used in this application, including the claims. Thus, for example, reference to "a subject" includes a plurality of subjects, unless the context clearly is to the contrary (e.g., a plurality of subjects), and so forth.

15

Throughout this specification and the claims, the terms "comprise," "comprises," and "comprising" are used in a non-exclusive sense, except where the context requires otherwise. Likewise, the term "include" and its grammatical variants are intended to be non-limiting, such that recitation of items in a list is not to the exclusion of other like items that can be substituted or added to the listed items.

20

For the purposes of this specification and appended claims, unless otherwise indicated, all numbers expressing amounts, sizes, dimensions, proportions, shapes, formulations, parameters, percentages, parameters, quantities, characteristics, and other numerical values used in the specification and claims, are to be understood as being modified in all instances by the term "about" even though the term "about" may not expressly appear with the value, amount or range. Accordingly, unless indicated to the contrary, the numerical parameters set forth in the following specification and attached claims are not and need not be exact, but may be approximate and/or larger or smaller as desired, reflecting tolerances, conversion factors, rounding off, measurement error and the like, and other factors known to those of skill in the art depending on the desired properties sought to be obtained by the presently disclosed subject matter. For example, the term "about," when referring to a value can be meant to encompass variations of, in

25  
30

some embodiments,  $\pm 100\%$  in some embodiments  $\pm 50\%$ , in some embodiments  $\pm 20\%$ ,  
in some embodiments  $\pm 10\%$ , in some embodiments  $\pm 5\%$ , in some embodiments  $\pm 1\%$ ,  
in some embodiments  $\pm 0.5\%$ , and in some embodiments  $\pm 0.1\%$  from the specified  
amount, as such variations are appropriate to perform the disclosed methods or employ  
5 the disclosed compositions.

Further, the term "about" when used in connection with one or more numbers or  
numerical ranges, should be understood to refer to all such numbers, including all  
numbers in a range and modifies that range by extending the boundaries above and below  
the numerical values set forth. The recitation of numerical ranges by endpoints includes  
10 all numbers, e.g., whole integers, including fractions thereof, subsumed within that range  
(for example, the recitation of 1 to 5 includes 1, 2, 3, 4, and 5, as well as fractions thereof,  
e.g., 1.5, 2.25, 3.75, 4.1, and the like) and any range within that range.

Although the foregoing subject matter has been described in some detail by way  
15 of illustration and example for purposes of clarity of understanding, it will be understood  
by those skilled in the art that certain changes and modifications can be practiced within  
the scope of the appended claims.

## THAT WHICH IS CLAIMED:

1. An ultrasound-detectable marker for monitoring a postoperative site, wherein the ultrasound-detectable marker comprises one or more resorbable polymers,  
5 one or more non-resorbable polymers, one or more non-polymeric materials, or any combinations thereof; and wherein the ultrasound-detectable marker is adapted for placement underneath, adjacent to, or above one or more vessels at the postoperative site.
2. The ultrasound-detectable marker of claim 1, wherein the ultrasound-  
10 detectable marker comprises one or more resorbable polymers selected from the group consisting of poly(lactic-co-glycolic acid) (PLGA), a polylactide (PLA), polyglycolide (PGA), polycaprolactone, a polyhydroxyalkanoate (PHA), polydioxanone, polyethylene glycol, collagen, hyaluronate, and copolymers thereof.
- 15 3. The ultrasound-detectable marker of claim 2, wherein the one or more resorbable polymers is selected from the group consisting of PLA and PGA.
4. The ultrasound-detectable marker of claim 3, wherein the one or more resorbable polymers is PLGA.  
20
5. The ultrasound-detectable marker of claim 1, wherein the ultrasound-detectable marker comprises two or more resorbable polymer layers, wherein at least two resorbable polymer layers do not comprise the same resorbable polymer.
- 25 6. The ultrasound-detectable marker of claim 5, wherein the two resorbable polymer layers comprise PLA and PGA.
7. The ultrasound-detectable marker of claim 1, wherein the ultrasound-detectable marker comprises a varying ratio of two or more resorbable polymers.  
30

8. The ultrasound-detectable marker of claim 7, wherein the ultrasound-detectable marker comprises a varying ratio of PLA:PGA.

5 9. The ultrasound-detectable marker of any of claims 5-8, wherein the presence of two or more resorbable polymer layers and/or a varying ratio of two or more resorbable polymers creates an impedance change throughout the marker.

10 10. The ultrasound-detectable marker of claim 1, wherein the ultrasound-detectable marker comprises one or more non-resorbable polymers.

11. The ultrasound-detectable marker of claim 10, wherein the one or more non-resorbable polymers is selected from the group consisting of polycarbonate, polyetheretherketone, polypropylene, silicone, polyethylene, and combinations thereof.

15 12. The ultrasound-detectable marker of claim 1, wherein the ultrasound-detectable marker comprises one or more holes and/or slits adapted to inform a geometric position.

20 13. The ultrasound-detectable marker of claim 1, wherein the ultrasound-detectable marker comprises at least one eyelet hole adapted to secure the ultrasound-detectable marker to soft tissue near the postoperative site.

25 14. The ultrasound-detectable marker of claim 1, wherein the ultrasound-detectable marker comprises a divider adapted to separate at least two blood vessels.

15. The ultrasound-detectable marker of claim 14, wherein the at least two blood vessels are an artery and a vein.

30 16. The ultrasound-detectable marker of claim 1, wherein the ultrasound-detectable marker has a detectable *in vivo* lifetime during which the ultrasound-detectable marker remains detectable by ultrasound.

17. The ultrasound-detectable marker of any of claims 1-16, wherein the postoperative site comprises a vascular anastomosis site.

5 18. A method for monitoring a postoperative site, the method comprising:

(a) providing an ultrasound-detectable marker comprising one or more resorbable polymers, one or more non-resorbable polymers, one or more non-polymeric materials, or any combinations thereof; wherein the ultrasound-detectable marker is adapted for placement underneath, adjacent to, or above one or more vessels at the  
10 postoperative site;

(b) placing the ultrasound-detectable marker underneath, adjacent to, or above one or more vessels during or after surgery; and

(c) using a software algorithm to guide a user with an ultrasound probe to the location of the ultrasound-detectable marker post-surgery.

15

19. The method of claim 18, wherein using the software algorithm comprises one or more of:

(a) generating ultrasound waves;  
(b) receiving reflected ultrasound waves with a transducer;  
20 (c) generating at least one B-mode image;  
(d) segmenting the at least one B-mode image;  
(e) matching a template to the defined marker shape;  
(f) estimating a pose;  
(g) calculating a desired pose; and  
25 (h) giving a user guidance on repositioning the probe based on the desired pose.

20. The method of claim 19, wherein the method is repeated until the probe is positioned so that the desired pose is observed.

30

21. The method of claim 19, wherein more than one B-mode image is generated and segmented before matching a template to the defined marker shape.

22. The method of claim 18, further comprising using a second software algorithm to measure and display flow data from the at least one vessel.

23. The method of claim 22, wherein using the second software algorithm comprises one or more of:

- (a) generating ultrasound waves;
- 10 (b) receiving reflected ultrasound waves with a transducer;
- (c) confirming the desired pose;
- (d) collecting at least one B-mode image and at least one set of Doppler velocities;
- (e) spatially analyzing a power signal to calculate X/Y boundaries of the at  
15 least one vessel;
- (f) temporally analyzing multiple frames to differentiate the at least one vessel from another vessel;
- (g) integrating individual Doppler velocities over the calculated X/Y boundaries of the at least one vessel;
- 20 (h) averaging the multiple frames; and
- (i) quantitatively displaying the integrated, averaged Doppler velocities.

24. The method of claim 18, comprising determining a patency and/or a vascular health of the at least one vessel.

25

25. The method of claim 24, wherein the determining a patency and/or a vascular health of the at least one vessel comprises detecting a blood clot before complete occlusion occurs.

26. The method of claim 18, wherein the ultrasound-detectable marker comprises two or more resorbable polymer layers and/or a varying ratio of two or more

30

resorbable polymers and wherein the presence of two or more resorbable polymer layers and/or a varying ratio of two or more resorbable polymers creates an impedance change throughout the ultrasound-detectable marker.

5           27.     A method for orienting at least one vessel linearly in a plane during surgery, the method comprising:

- (a)     providing an ultrasound-detectable marker comprising one or more resorbable polymers, one or more non-resorbable polymers, one or more non-polymeric materials, or any combinations thereof; wherein the ultrasound-detectable marker is  
10     adapted for placement underneath, adjacent to, or above one or more vessels at a postoperative site;
- (b)     placing the ultrasound-detectable marker in a subject during surgery; and
- (c)     placing the at least one vessel on the ultrasound-detectable marker; and  
          wherein the at least one vessel is oriented linearly in a plane after being placed on  
15     the ultrasound-detectable marker.

          28.     The method of claim 27, wherein the at least one vessel is oriented in a parallel direction after being placed on the ultrasound-detectable marker.

20           29.     The method of claim 27, further comprising attaching the ultrasound-detectable marker to soft tissue adjacent to the postoperative site.

          30.     The method of claim 29, wherein attaching the ultrasound-detectable marker to soft tissue occurs by at least one method selected from the group consisting of  
25     suturing, using an adhesive, and using a hooking mechanism.

          31.     The method of claim 27, wherein the ultrasound-detectable marker comprises a divider to isolate each of the at least two vessels.

30           32.     The method of claim 27, wherein the ultrasound-detectable marker comprises two or more resorbable polymer layers and/or a varying ratio of two or more

resorbable polymers and wherein the presence of two or more resorbable polymer layers and/or a varying ratio of two or more resorbable polymers creates an impedance change throughout the ultrasound-detectable marker.

5

1/19

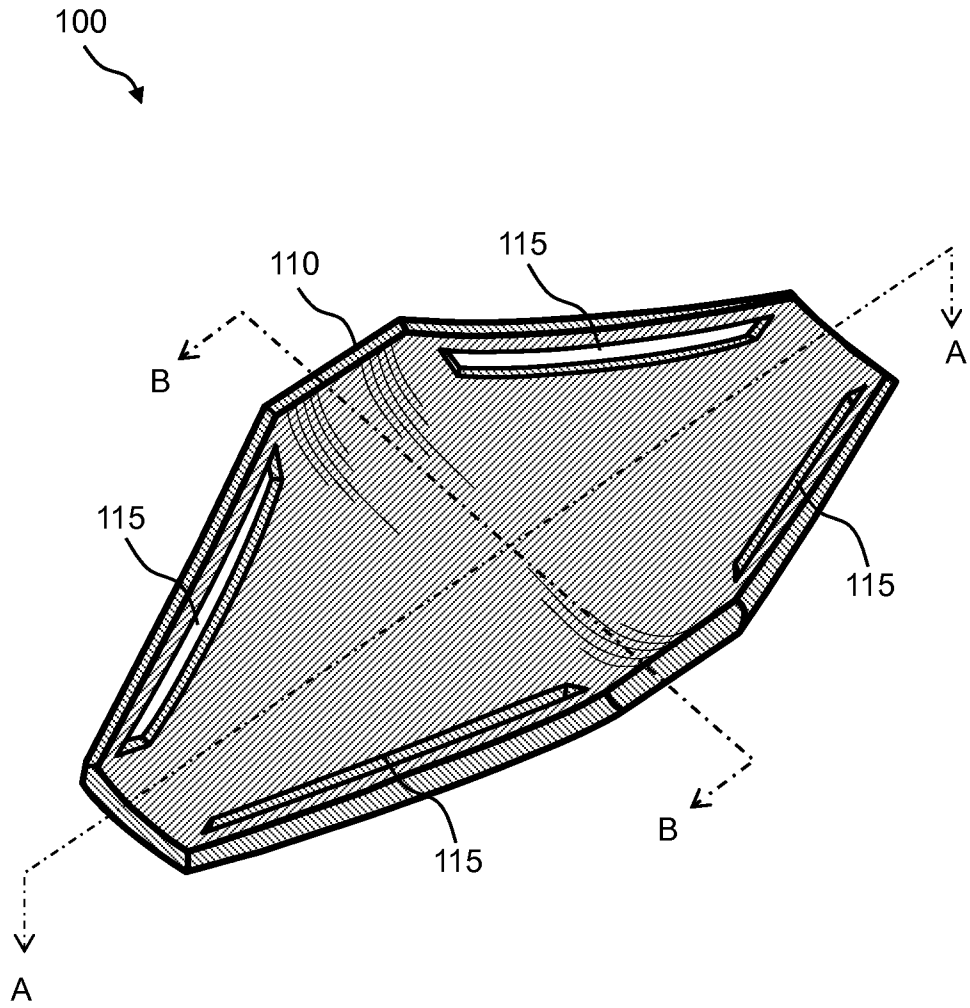

FIG. 1

2/19

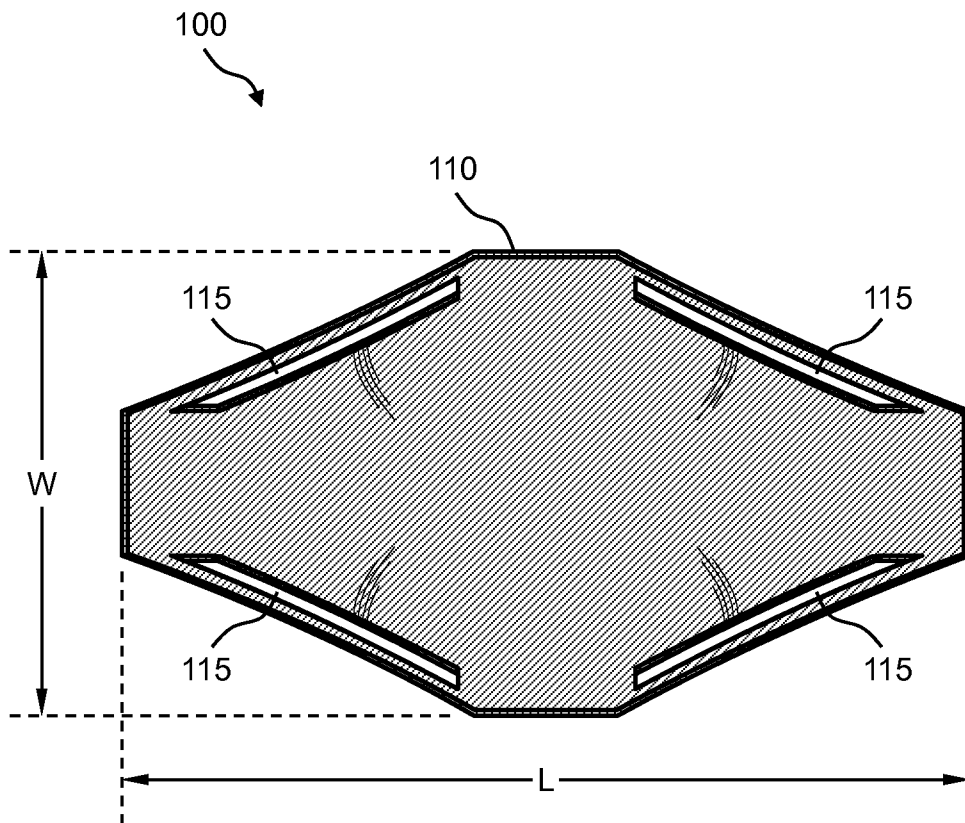

FIG. 2

3/19

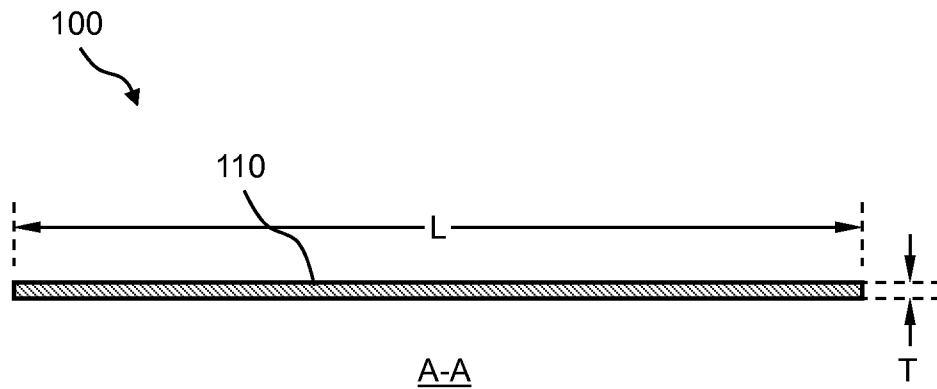

FIG. 3A

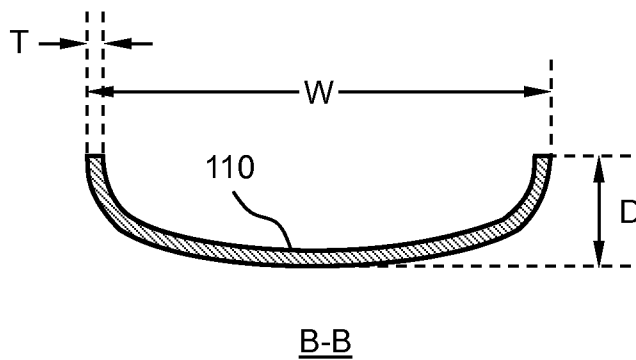

FIG. 3B

4/19

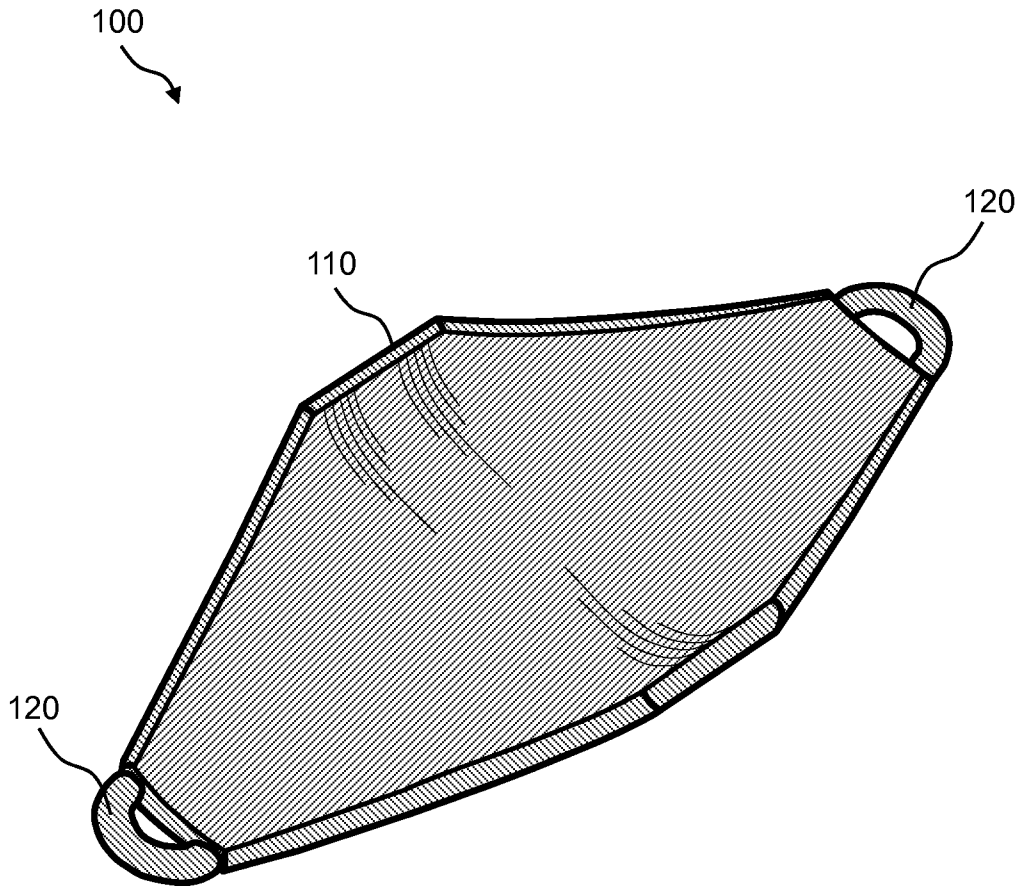

FIG. 4

5/19

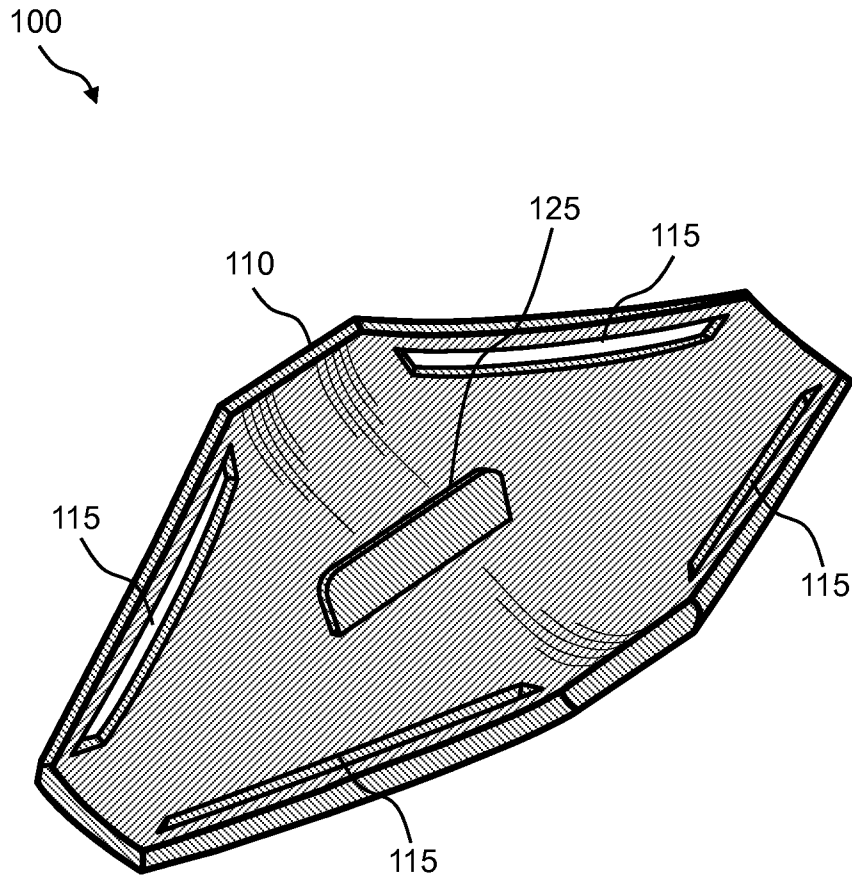

FIG. 5

6/19

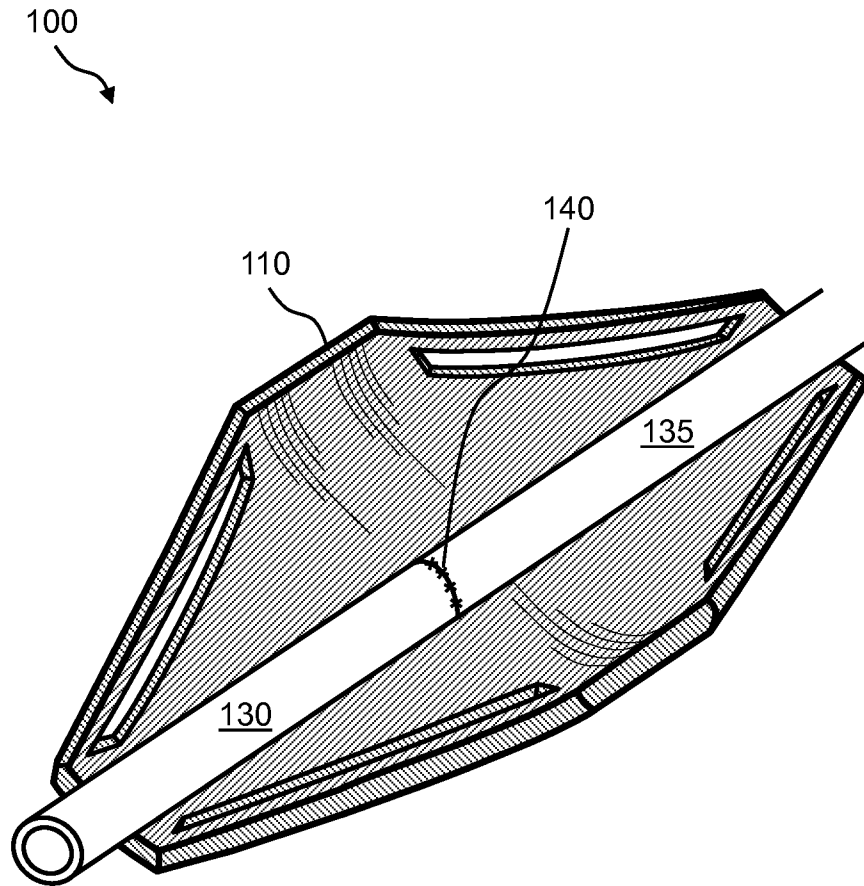

FIG. 6

7/19

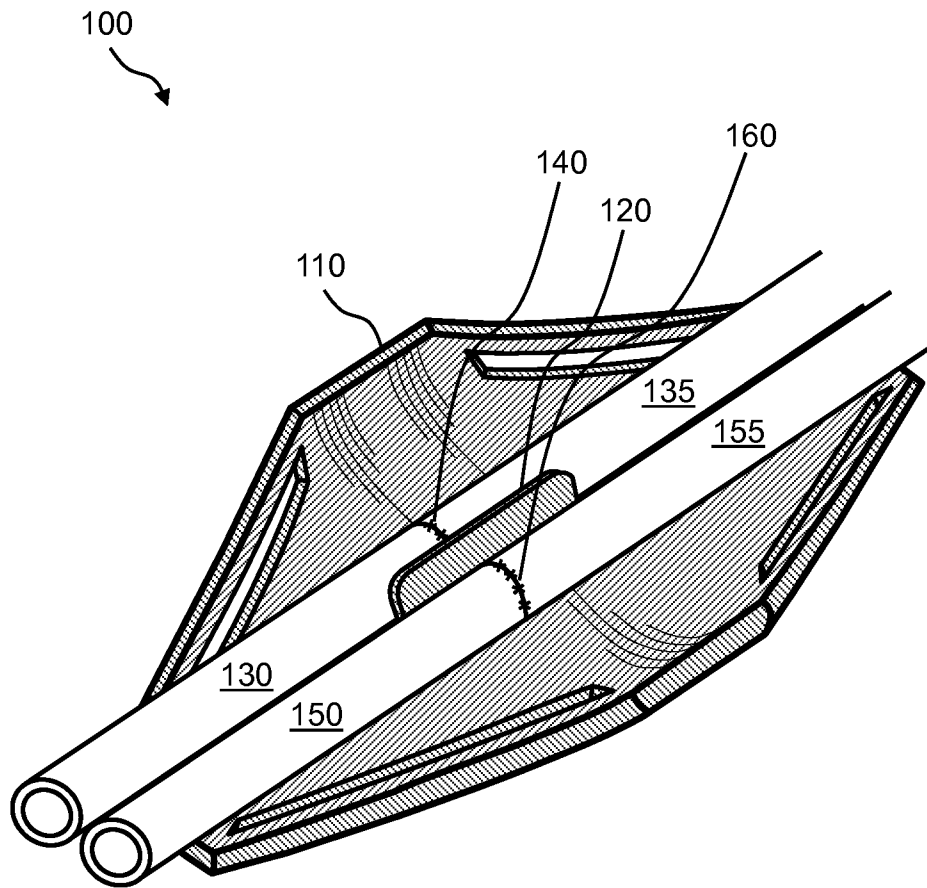

FIG. 7

8/19

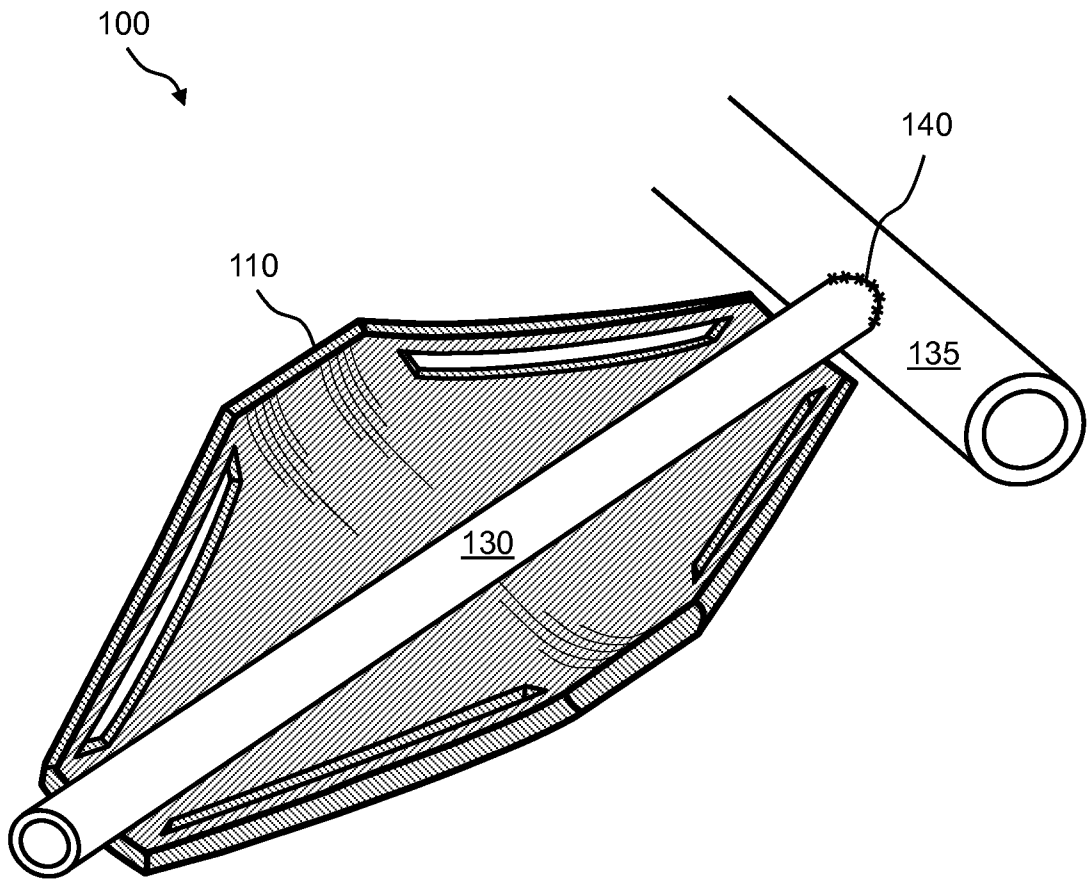

FIG. 8

9/19

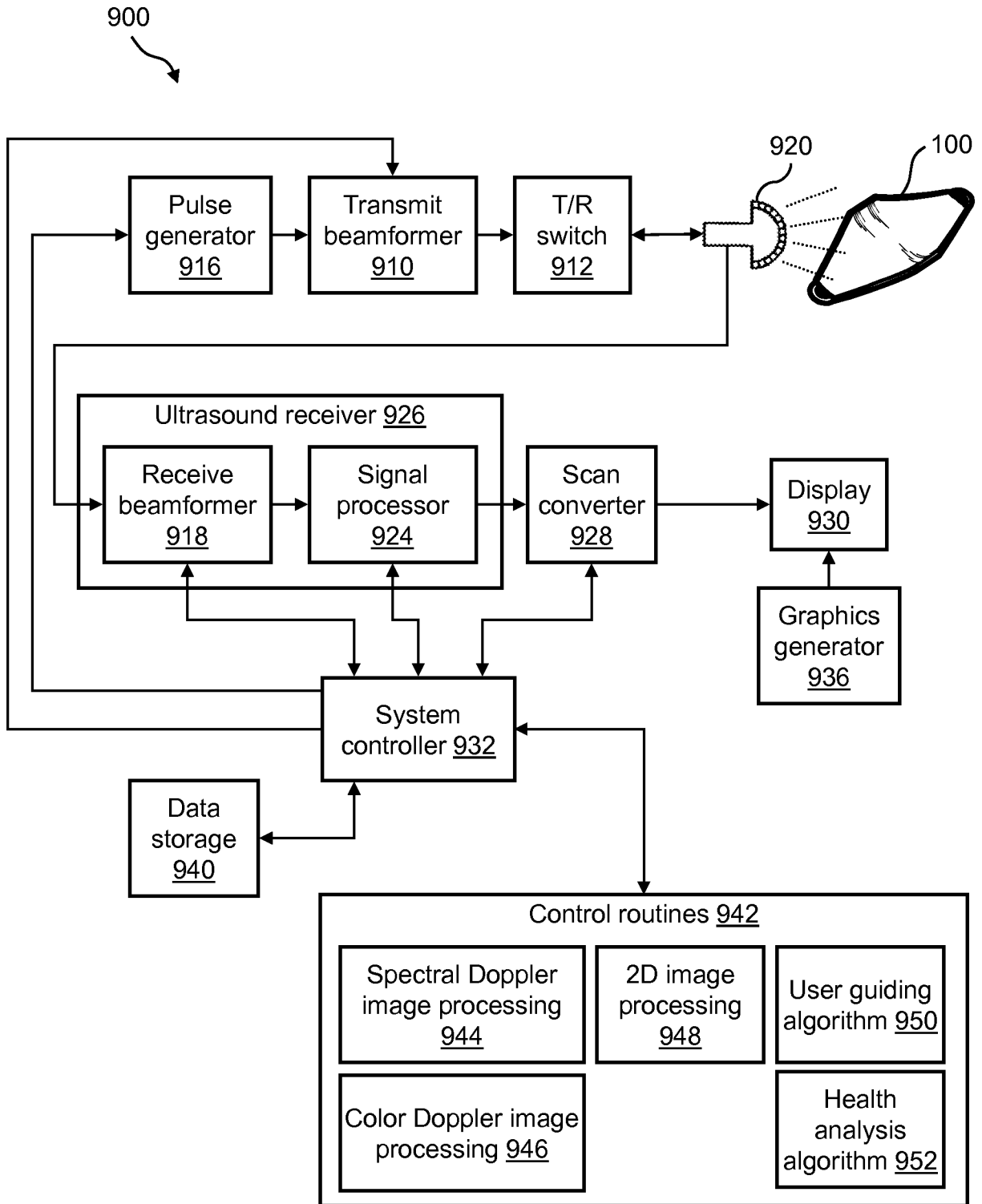

FIG. 9

10/19

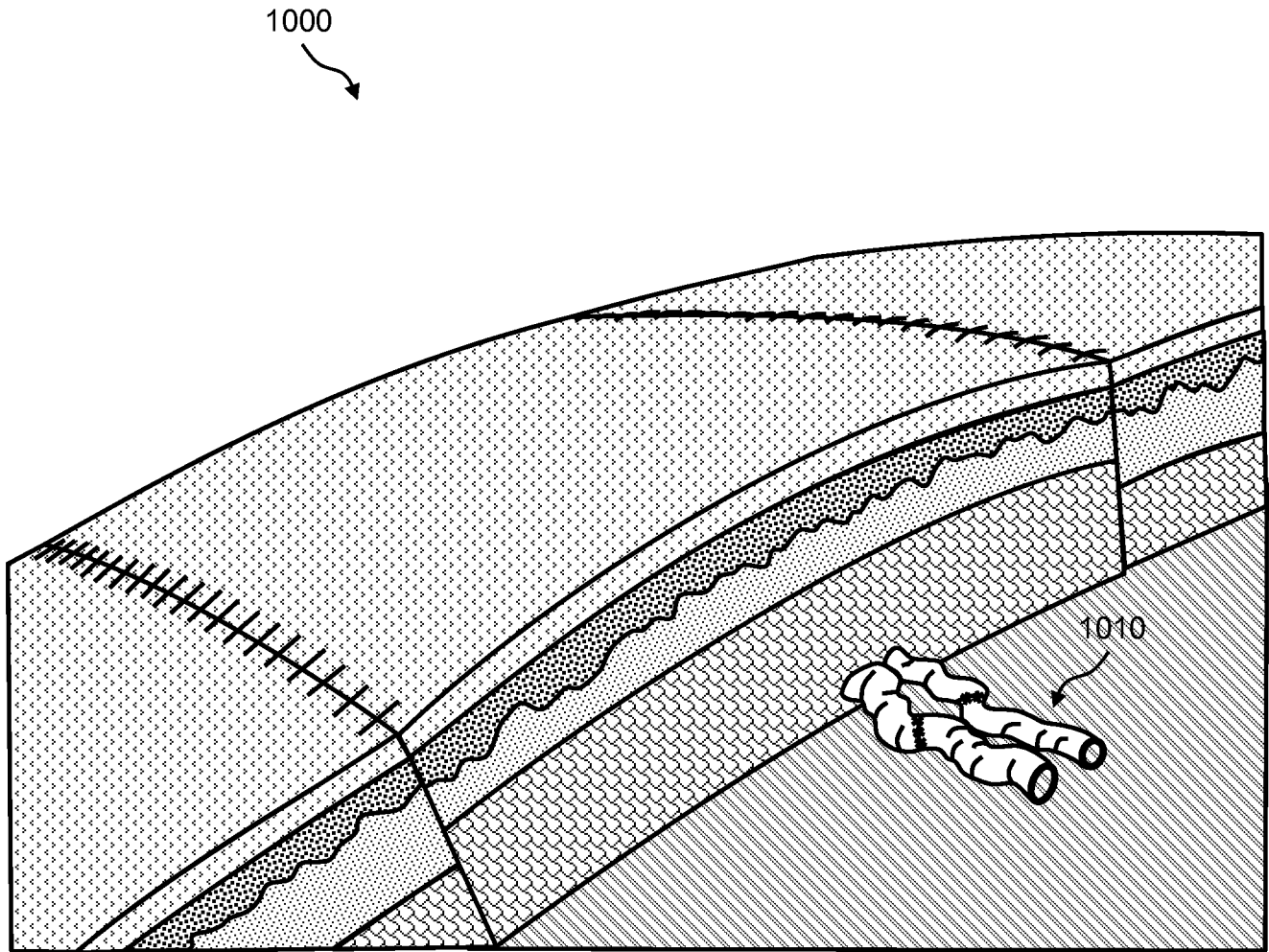

FIG. 10

11/19

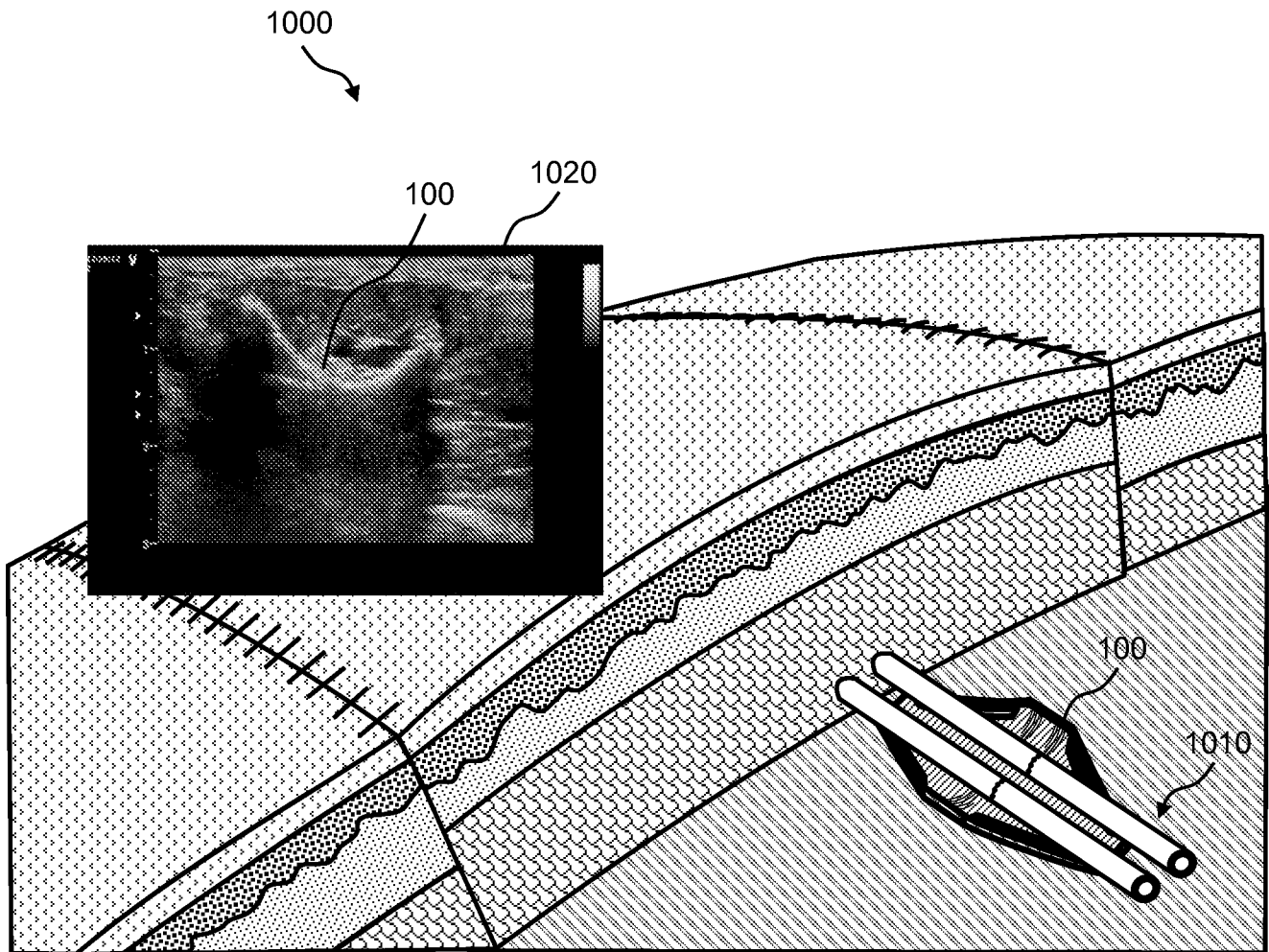

FIG. 11

12/19

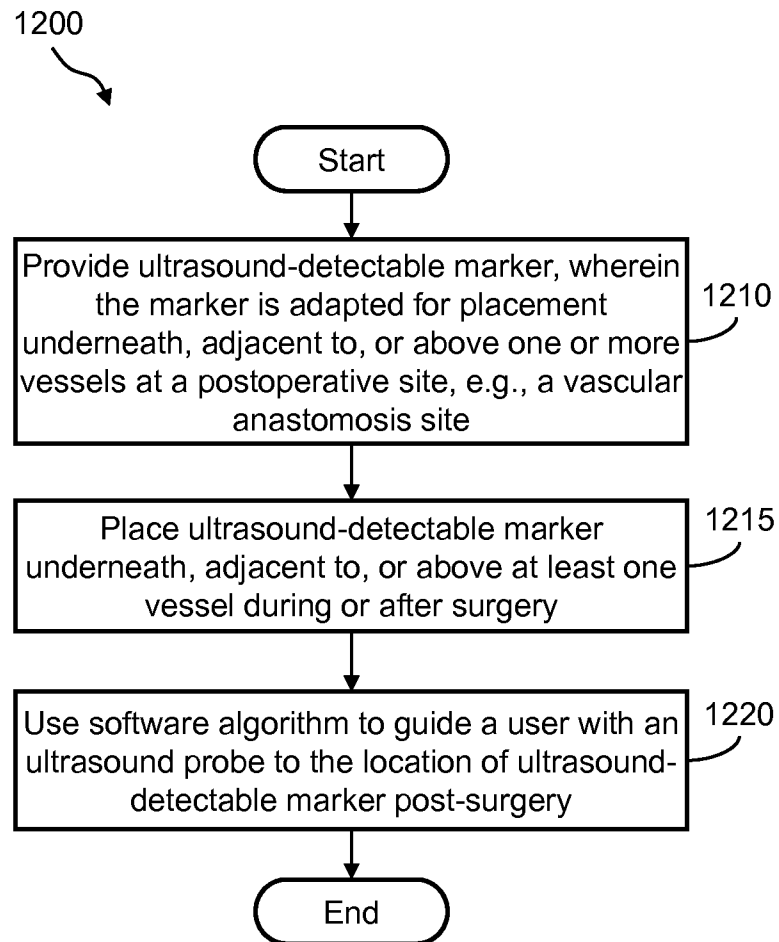

FIG. 12

13/19

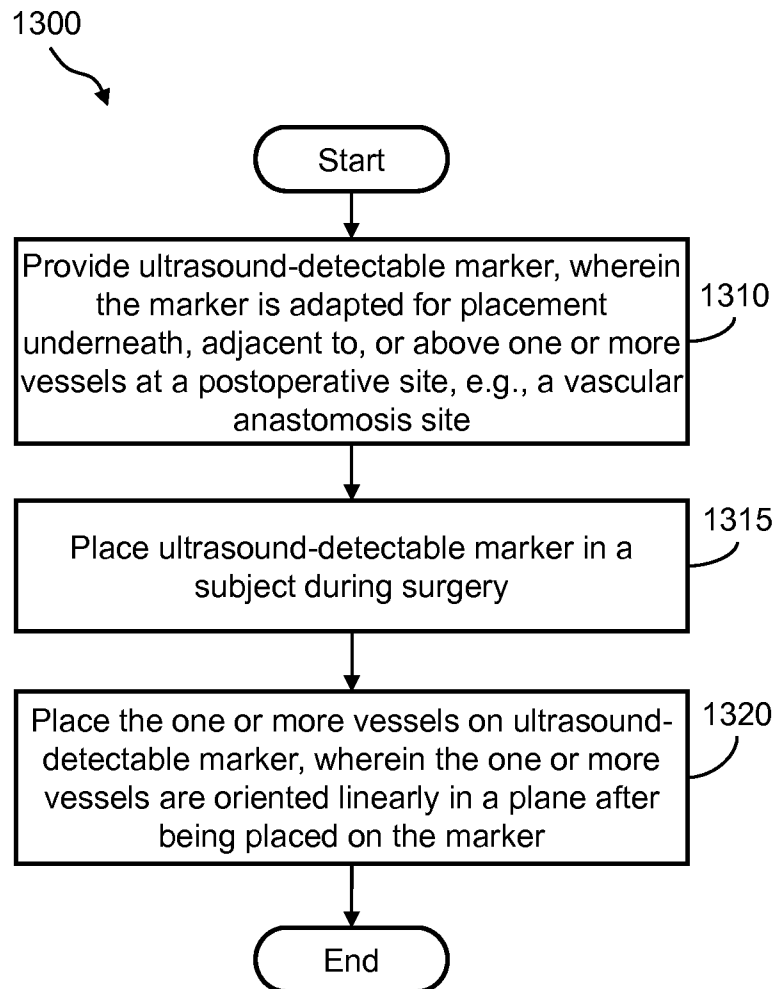

FIG. 13

14/19

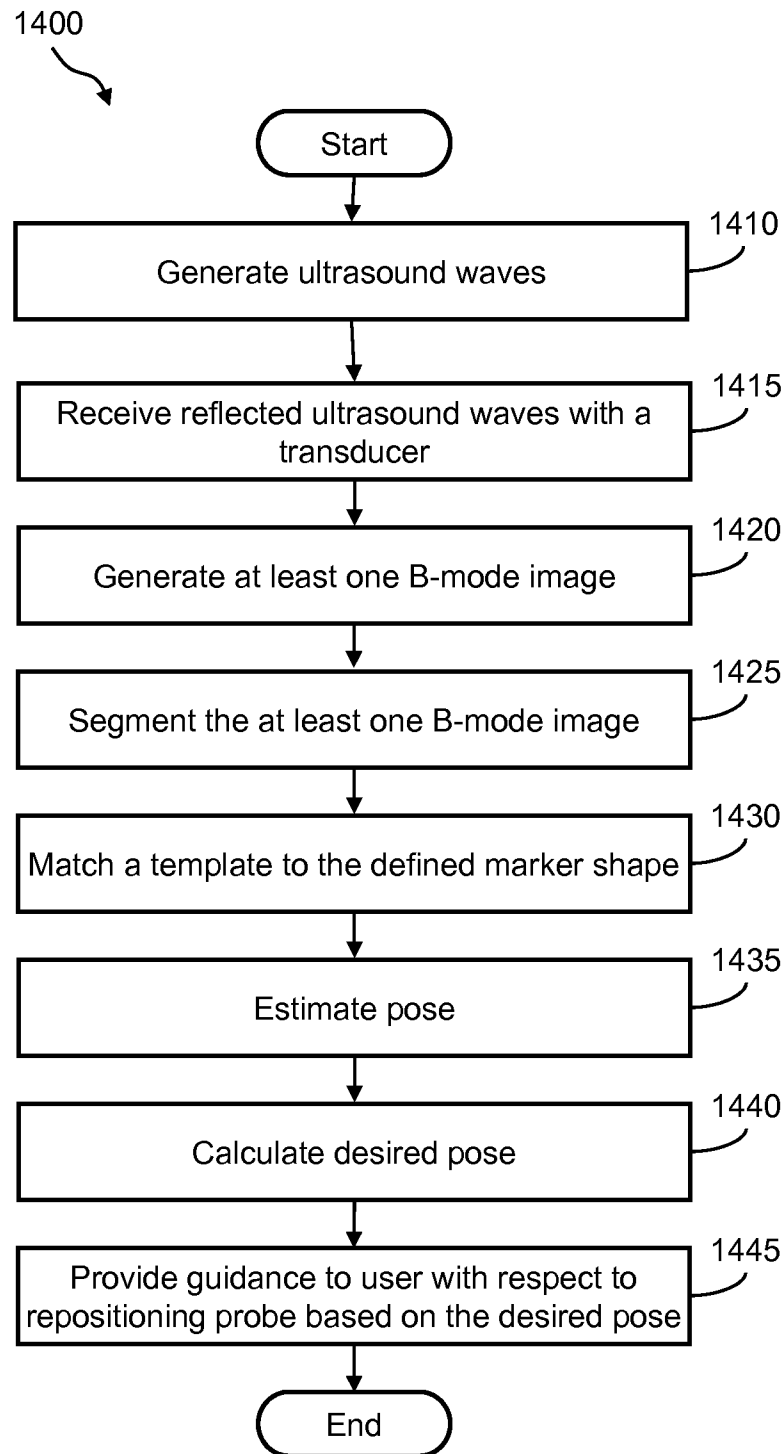

FIG. 14

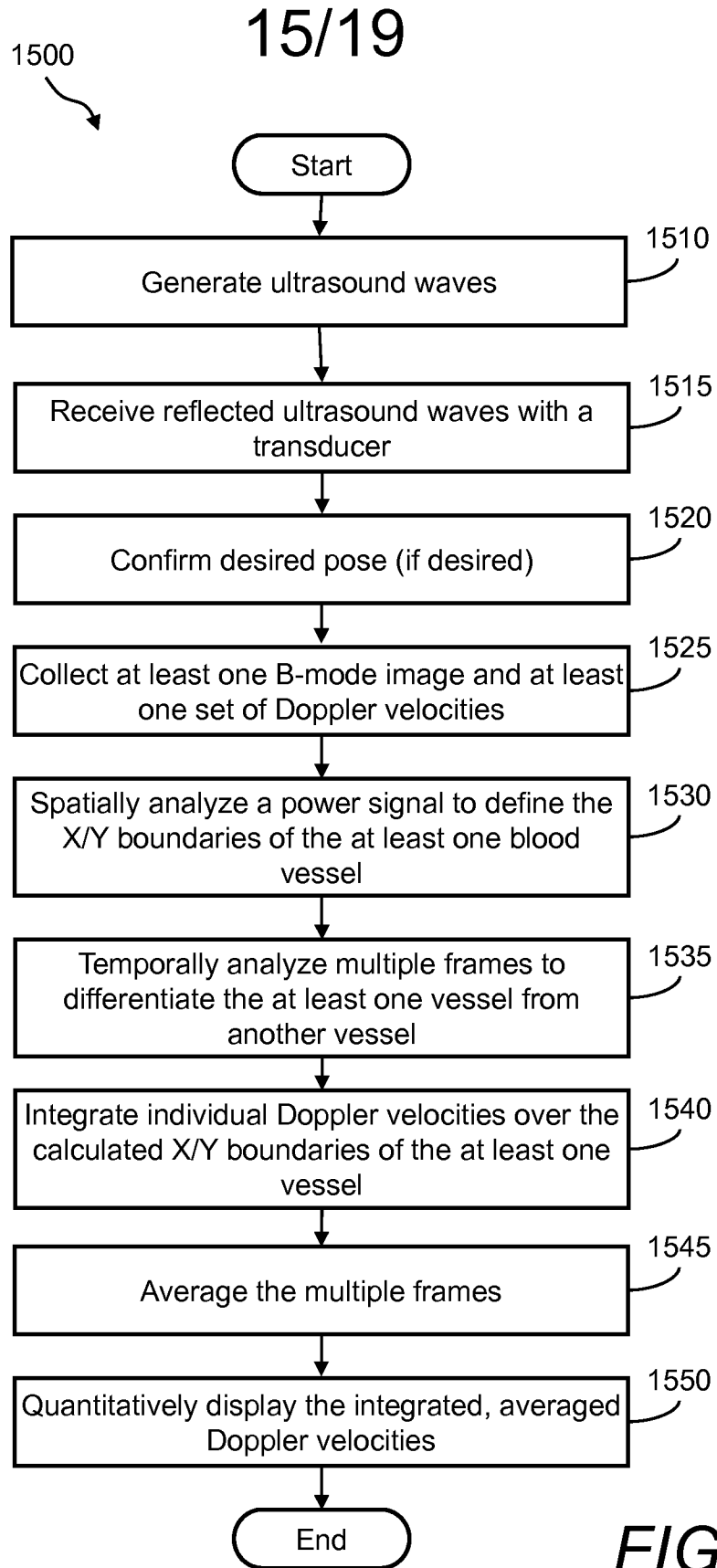

FIG. 15

16/19

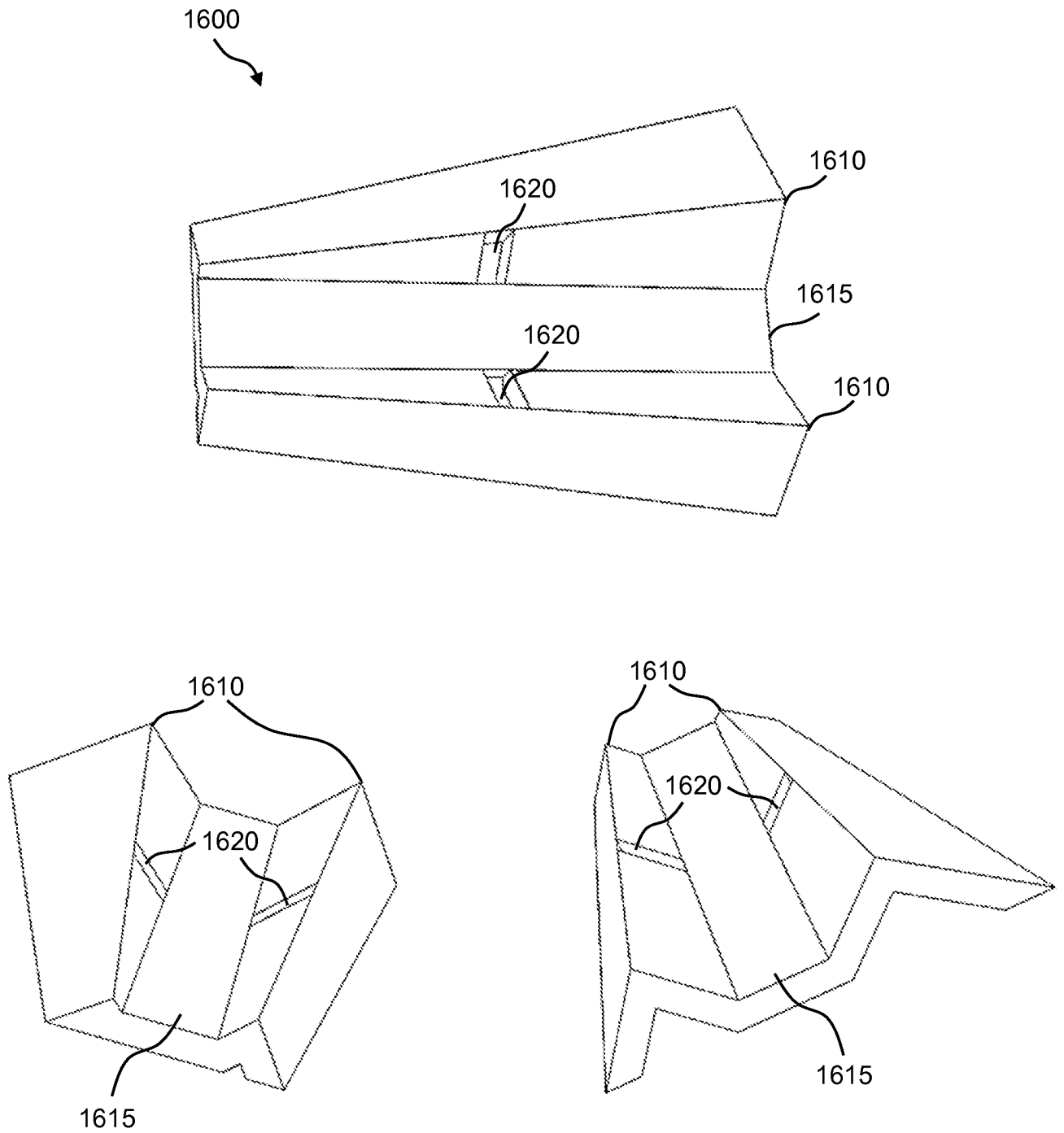

FIG. 16

17/19

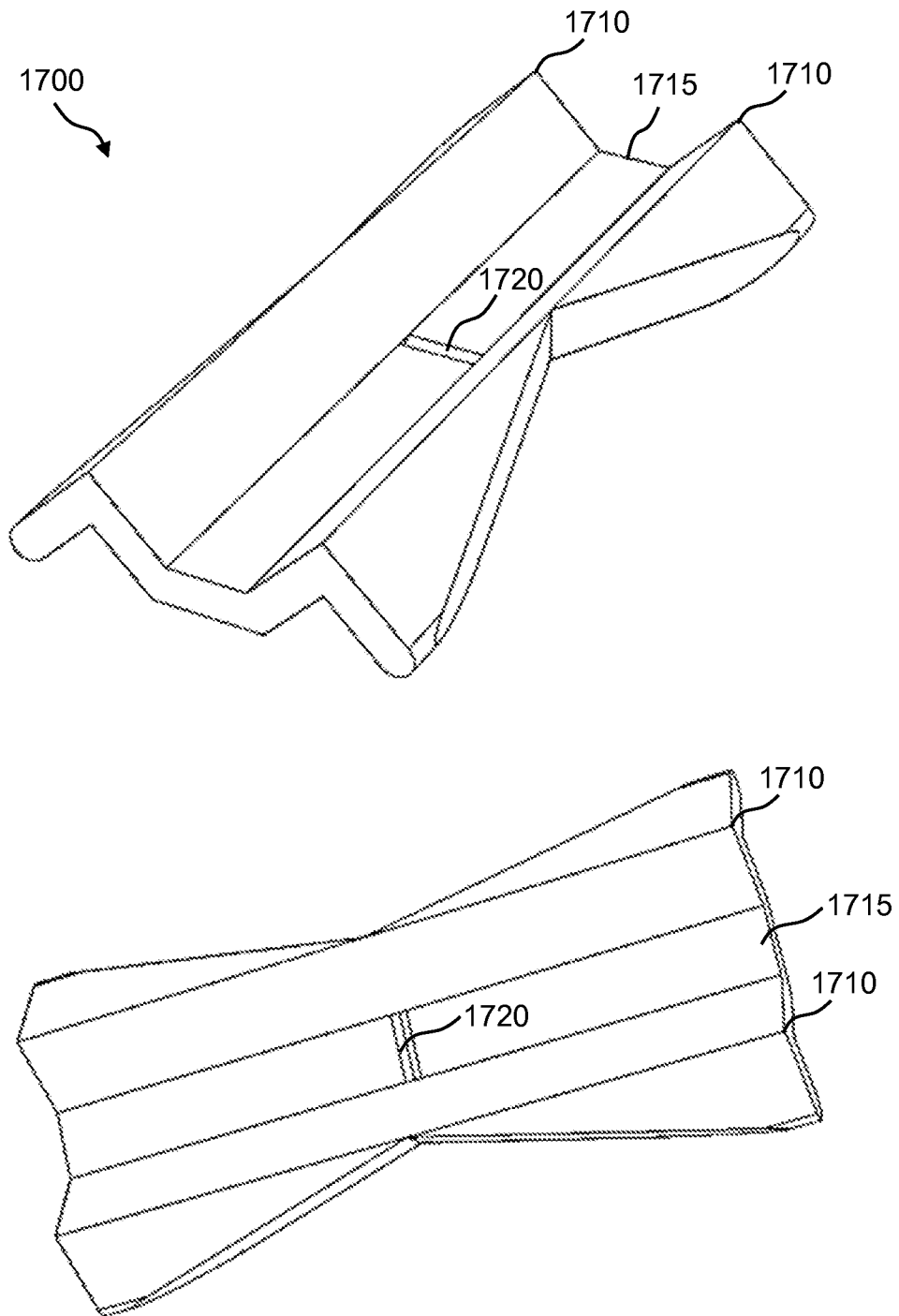

FIG. 17

18/19

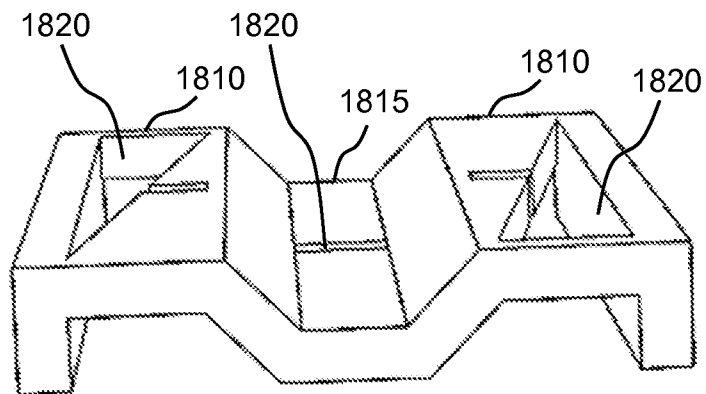
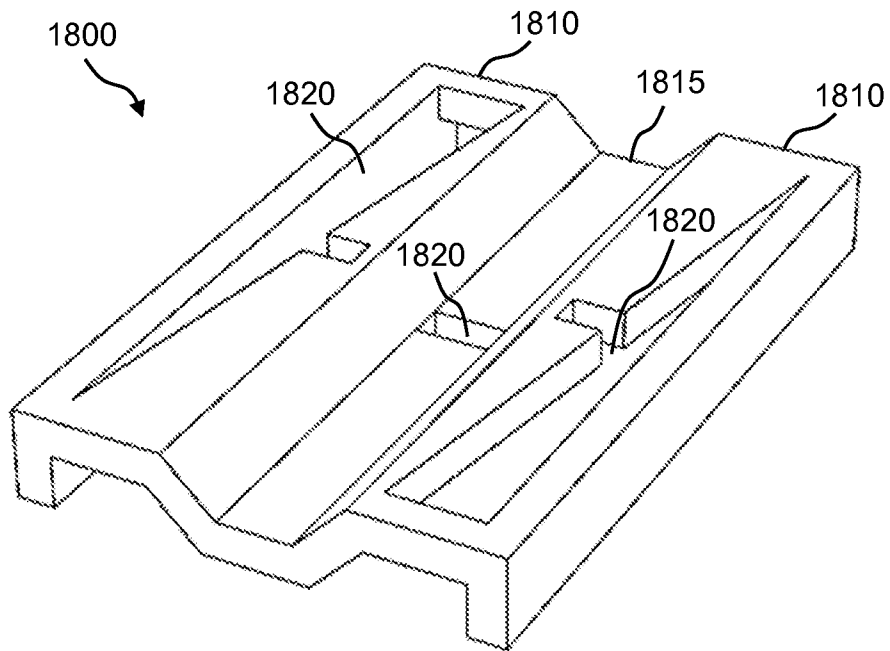

FIG. 18

19/19

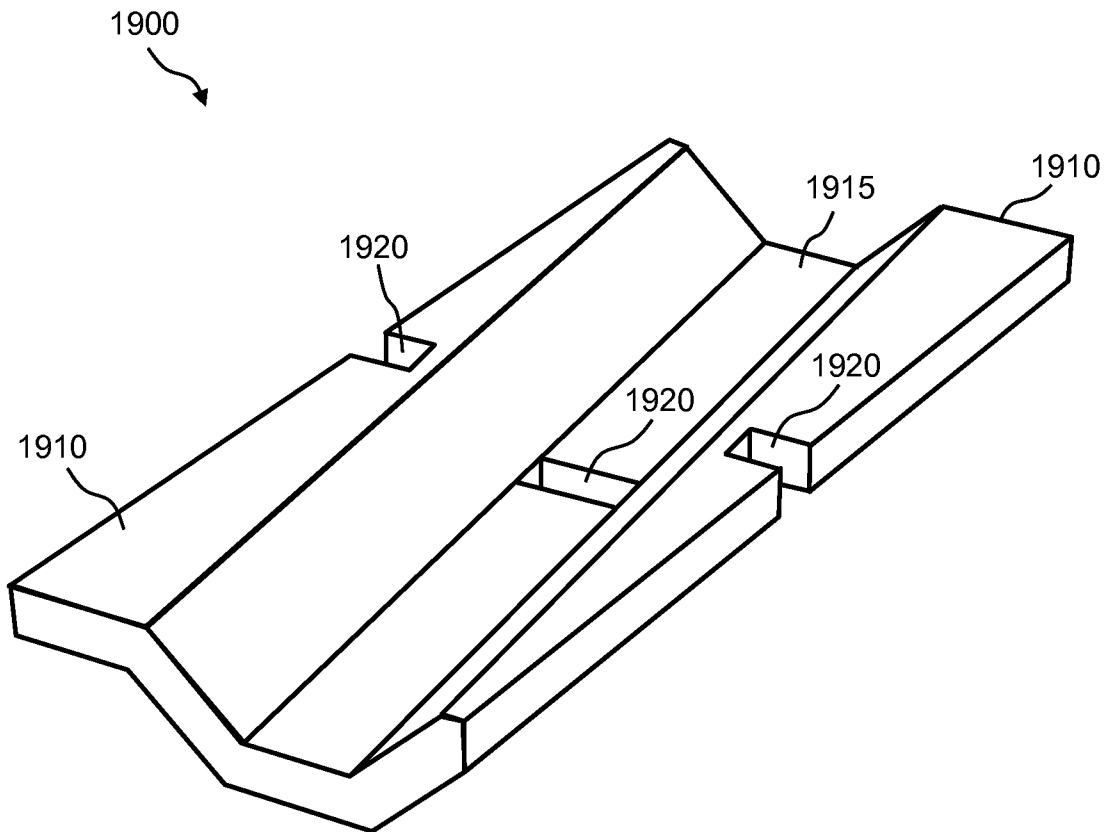

FIG. 19

## INTERNATIONAL SEARCH REPORT

International application No.  
**PCT/US2014/012274****A. CLASSIFICATION OF SUBJECT MATTER****A61B 8/00(2006.01)i**

According to International Patent Classification (IPC) or to both national classification and IPC

**B. FIELDS SEARCHED**

Minimum documentation searched (classification system followed by classification symbols)

A61B 8/00; A61B 5/05; A61B 8/12; A61B 17/11; A61B 8/14; A61B 19/00; A61B 6/00; A61B 5/103

Documentation searched other than minimum documentation to the extent that such documents are included in the fields searched

Korean utility models and applications for utility models

Japanese utility models and applications for utility models

Electronic data base consulted during the international search (name of data base and, where practicable, search terms used)

eKOMPASS(KIPO internal) &amp; Keywords: ultrasound, marker, vessel, resorbable, and similar terms.

**C. DOCUMENTS CONSIDERED TO BE RELEVANT**

Category*	Citation of document, with indication, where appropriate, of the relevant passages	Relevant to claim No.
Y	US 2002-0151797 A1 (VALENTINO MONTEGRANDE) 17 October 2002 See paragraphs [0069]-[0084] and figures 1-8.	1-4, 10-13, 16
A		5-9, 14-15
Y	US 4,041,931 A (DONALD P. ELLIOTT et al.) 16 August 1977 See column 2, line 46 - column 3, line 37; claim 1; and figures 1-4.	1-4, 10-13, 16
A	US 2003-0139669 A1 (VALENTINO MONTEGRANDE) 24 July 2003 See paragraphs [0057]-[0074] and figures 1-4.	1-16
A	US 4,202,349 A (JAMES W. JONES) 13 May 1980 See column 2, line 52 - column 3, line 65; and figures 1-6.	1-16
A	US 6,270,458 B1 (OFER BARNEA) 07 August 2001 See column 5, line 29 - column 7, line 7; and figures 1-2.	1-16
A	US 4,787,391 A (JOHN A. ELEFTERIADES) 29 November 1988 See column 3, line 34 - column 4, line 47; and figures 1-4.	1-16

 Further documents are listed in the continuation of Box C. See patent family annex.

\* Special categories of cited documents:

"A" document defining the general state of the art which is not considered to be of particular relevance

"E" earlier application or patent but published on or after the international filing date

"L" document which may throw doubts on priority claim(s) or which is cited to establish the publication date of another citation or other special reason (as specified)

"O" document referring to an oral disclosure, use, exhibition or other means

"P" document published prior to the international filing date but later than the priority date claimed

"T" later document published after the international filing date or priority date and not in conflict with the application but cited to understand the principle or theory underlying the invention

"X" document of particular relevance; the claimed invention cannot be considered novel or cannot be considered to involve an inventive step when the document is taken alone

"Y" document of particular relevance; the claimed invention cannot be considered to involve an inventive step when the document is combined with one or more other such documents, such combination being obvious to a person skilled in the art

"&amp;" document member of the same patent family

Date of the actual completion of the international search

28 May 2014 (28.05.2014)

Date of mailing of the international search report

**28 May 2014 (28.05.2014)**

Name and mailing address of the ISA/KR

International Application Division  
Korean Intellectual Property Office  
189 Cheongsu-ro, Seo-gu, Daejeon Metropolitan City, 302-701,  
Republic of Korea

Facsimile No. +82-42-472-7140

Authorized officer

NHO, Ji Myong

Telephone No. +82-42-481-8528



**Box No. II Observations where certain claims were found unsearchable (Continuation of item 2 of first sheet)**

This international search report has not been established in respect of certain claims under Article 17(2)(a) for the following reasons:

1.  Claims Nos.: 18-32  
because they relate to subject matter not required to be searched by this Authority, namely:  
Claims 18-32 pertain to methods for treatment of the human body by therapy or surgery, as well as diagnostic methods, and thus relate to a subject matter which this International Searching Authority is not required to search under PCT Article 17(2)(a)(i) and PCT Rule 39.1(iv).
2.  Claims Nos.:  
because they relate to parts of the international application that do not comply with the prescribed requirements to such an extent that no meaningful international search can be carried out, specifically:
3.  Claims Nos.: 17  
because they are dependent claims and are not drafted in accordance with the second and third sentences of Rule 6.4(a).

**Box No. III Observations where unity of invention is lacking (Continuation of item 3 of first sheet)**

This International Searching Authority found multiple inventions in this international application, as follows:

1.  As all required additional search fees were timely paid by the applicant, this international search report covers all searchable claims.
2.  As all searchable claims could be searched without effort justifying an additional fees, this Authority did not invite payment of any additional fees.
3.  As only some of the required additional search fees were timely paid by the applicant, this international search report covers only those claims for which fees were paid, specifically claims Nos.:
4.  No required additional search fees were timely paid by the applicant. Consequently, this international search report is restricted to the invention first mentioned in the claims; it is covered by claims Nos.:

**Remark on Protest**

- The additional search fees were accompanied by the applicant's protest and, where applicable, the payment of a protest fee.
- The additional search fees were accompanied by the applicant's protest but the applicable protest fee was not paid within the time limit specified in the invitation.
- No protest accompanied the payment of additional search fees.

**INTERNATIONAL SEARCH REPORT**

Information on patent family members

International application No.

**PCT/US2014/012274**

Patent document cited in search report	Publication date	Patent family member(s)	Publication date
US 2002-0151797 A1	17/10/2002	AU 2002-315409 A1 EP 1476078 A2 EP 1476078 A4 US 6544185 B2 WO 03-034894 A2 WO 03-034894 A3	06/05/2003 17/11/2004 17/03/2010 08/04/2003 01/05/2003 05/06/2003
US 4041931 A	16/08/1977	None	
US 2003-0139669 A1	24/07/2003	AU 2002-357167 A1 US 6654629 B2 US 7074189 B1 WO 03-061503 A1 WO 2005-051202 A1	02/09/2003 25/11/2003 11/07/2006 31/07/2003 09/06/2005
US 4202349 A	13/05/1980	None	
US 6270458 B1	07/08/2001	AU 2000-33693 A1 EP 1158901 A1 EP 1158901 A4 WO 00-51494 A1	21/09/2000 05/12/2001 05/04/2006 08/09/2000
US 4787391 A	29/11/1988	None	

专利名称(译)	超声检测标记，超声系统和监测血管流动和通畅的方法		
公开(公告)号	<a href="#">EP2945543A1</a>	公开(公告)日	2015-11-25
申请号	EP2014740843	申请日	2014-01-21
[标]申请(专利权)人(译)	约翰霍普金斯大学		
申请(专利权)人(译)	约翰·霍普金斯大学		
当前申请(专利权)人(译)	约翰·霍普金斯大学		
[标]发明人	OBRIEN COON DEVIN HARFMANN KAITLYN LAI TING YU NARROW DAVID LIGHTMAN ADAM YOUSEPH YAZDI		
发明人	O'BRIEN-COON, DEVIN HARFMANN, KAITLYN LAI, TING, YU NARROW, DAVID LIGHTMAN, ADAM YOUSEPH, YAZDI		
IPC分类号	A61B8/00 A61B90/00		
CPC分类号	A61B8/4483 A61B8/0841 A61B8/0891 A61B8/14 A61B8/4444 A61B8/463 A61B8/488 A61B8/5207 A61B90/39 A61B2017/00004 A61B2017/1107 A61B2017/1132 A61B2017/1135 A61B2090/378 A61B2090/3908 A61B2090/3925 A61B2090/3991		
优先权	61/754177 2013-01-18 US 61/819979 2013-05-06 US		
其他公开文献	EP2945543A4		
外部链接	<a href="#">Espacenet</a>		

#### 摘要(译)

公开了一种超声可检测标记物，超声系统和用于监测血管流动和通畅的方法。超声可检测标记物包含一种或多种可再吸收的聚合物，一种或多种不可再吸收的聚合物，一种或多种非聚合物材料，或其任何组合。超声可检测标记物适于放置在术后部位（例如血管吻合部位）的一个或多个血管下方，邻近或上方。此外，超声成像系统包括用于超声可检测标记的某些用户引导软件和/或健康分析软件。