

(19) World Intellectual Property Organization
International Bureau



(43) International Publication Date
13 April 2006 (13.04.2006)

PCT

(10) International Publication Number
WO 2006/038180 A1

- (51) International Patent Classification:
A61B 8/14 (2006.01) G01S 7/52 (2006.01)
G01S 15/89 (2006.01)
- (21) International Application Number:
PCT/IB2005/053249
- (22) International Filing Date: 3 October 2005 (03.10.2005)
- (25) Filing Language: English
- (26) Publication Language: English
- (30) Priority Data:
60/617,492 8 October 2004 (08.10.2004) US
- (71) Applicant (for all designated States except US): **KONINKLIJKE PHILIPS ELECTRONICS N.V.** [NL/NL]; Groenewoudseweg 1, NL-5621 BA Eindhoven (NL).
- (72) Inventors; and
- (75) Inventors/Applicants (for US only): **FRISA, Janice** [US/US]; P.O. Box 3003, Bothell, Washington 98041-3003 (US). **THIELE, Karl** [US/US]; P.O. Box 3003, Bothell, Washington 98041-3003 (US). **PRATER, David** [US/US]; P.O. Box 3003, Bothell, Washington 98041-3003 (US). **LIU, Larry Lingnan** [US/US]; P.O. Box 3003, Bothell, Washington 98041-3003 (US).
- (74) Common Representative: **KONINKLIJKE PHILIPS ELECTRONICS N.V.**; c/o W. Brinton Yorks, Jr. P.O. Box 3003, 22100 Bothell Everett Highway, Bothell, Washington 98041-3003 (US).
- (81) Designated States (unless otherwise indicated, for every kind of national protection available): AE, AG, AL, AM, AT, AU, AZ, BA, BB, BG, BR, BW, BY, BZ, CA, CH, CN, CO, CR, CU, CZ, DE, DK, DM, DZ, EC, EE, EG, ES, FI, GB, GD, GE, GH, GM, HR, HU, ID, IL, IN, IS, JP, KE, KG, KM, KP, KR, KZ, LC, LK, LR, LS, LT, LU, LV, LY, MA, MD, MG, MK, MN, MW, MX, MZ, NA, NG, NI, NO, NZ, OM, PG, PH, PL, PT, RO, RU, SC, SD, SE, SG, SK, SL, SM, SY, TJ, TM, TN, TR, TT, TZ, UA, UG, US, UZ, VC, VN, YU, ZA, ZM, ZW.
- (84) Designated States (unless otherwise indicated, for every kind of regional protection available): ARIPO (BW, GH, GM, KE, LS, MW, MZ, NA, SD, SL, SZ, TZ, UG, ZM, ZW), Eurasian (AM, AZ, BY, KG, KZ, MD, RU, TJ, TM), European (AT, BE, BG, CH, CY, CZ, DE, DK, EE, ES, FI, FR, GB, GR, HU, IE, IS, IT, LT, LU, LV, MC, NL, PL, PT, RO, SE, SI, SK, TR), OAPI (BF, BJ, CF, CG, CI, CM, GA, GN, GQ, GW, ML, MR, NE, SN, TD, TG).

[Continued on next page]

(54) Title: THREE DIMENSIONAL DIAGNOSTIC ULTRASOUND IMAGING SYSTEM WITH IMAGE REVERSAL AND INVERSION

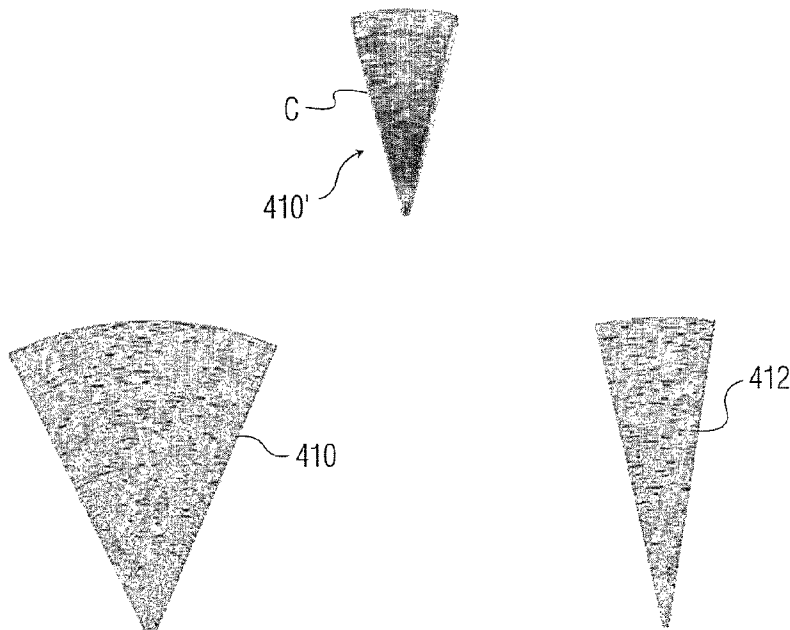

(57) Abstract: A three dimensional ultrasonic imaging system acquires 3D image data from a volumetric region and processes the image data to produce a live 3D image of the volumetric region in a given orientation. A user control can be switched by a user to present the image in a different orientation if desired. Both the anatomy in the 3D image and the image format can be inverted, and the left-right appearance of the 3D image can be reversed with a corresponding front-back reversal of the anatomy.

WO 2006/038180 A1



Declaration under Rule 4.17:

— *as to applicant's entitlement to apply for and be granted a patent (Rule 4.17(ii))*

For two-letter codes and other abbreviations, refer to the "Guidance Notes on Codes and Abbreviations" appearing at the beginning of each regular issue of the PCT Gazette.

Published:

— *with international search report*

THREE DIMENSIONAL DIAGNOSTIC ULTRASOUND
IMAGING SYSTEM WITH IMAGE REVERSAL AND INVERSION

5 This invention relates to ultrasonic diagnostic
imaging and, in particular, to a three dimensional
ultrasonic imaging system in which 3D images can be
easily inverted and reversed for viewing from
different diagnostic perspectives.

10 Live, real time 3D imaging has been commercially
available for several years. Live 3D imaging, even
more than standard 2D imaging, poses tradeoffs of
image quality versus frame rate. For good image
quality it is desirable to transmit and receive a
15 large number of well-focused scan lines over the
image field. For high real time frame rate,
particularly useful when imaging a moving object such
as the heart, it is desirable to transmit and receive
all of the scan lines for an image in a short period
of time. However, the transmission and reception of
20 scan lines is limited by the laws of physics
governing the speed of sound to 1540 m/sec. Thus,
depending upon the depth of the image (which
determines the time needed to wait for the return of
the echoes over the full depth of the image), a
25 determinable amount of time is required to transmit
and receive all of the scan lines for an image, which
may cause the frame rate of display to be
unacceptably low. A solution to this problem is to
reduce the number of scan lines and increase the
30 degree of multiline reception. This will increase
the frame rate, but possibly at the expense of
degradation in the image quality. In 3D imaging the
problem is even more acute, as hundreds or thousands
of scan lines may be needed to fully scan a
35 volumetric region. Another solution which reduces

the number of scan lines is to narrow the volume being scanned, which also increases the frame rate. But this may undesirably provide only a view of a small section of the anatomy which is the subject of the ultrasonic exam.

As previously mentioned, this dilemma presents itself most starkly when imaging a moving object such as the beating heart. An ingenious solution to the dilemma for 3D imaging of the heart is described in US Pat. 5,993,390. The approach taken in this patent is to divide the cardiac cycle into twelve phases. A region of the heart which is scanned during one-twelfth of the cardiac cycle will produce a substantially stationary (unblurred) image. The inventors in the patent determined that nine such regions comprise the full volume of the typical heart. Thus, the heart is scanned to acquire one of these nine subvolumes during each of the twelve phases of the heart cycle. Over a period of nine heartbeats a complete 3D image of the heart is pieced together from the subvolumes for each of the twelve phases of the heart cycle. When the complete images are displayed in real time in phase succession, the viewer is presented with a real time image of the heart. This is a replayed image, however, and not a current live image of the heart. It would be desirable to enable current live 3D imaging of a volumetric region sufficient to encompass the heart.

In accordance with the principles of the present invention, current live subvolumes of the heart are acquired in real time. The subvolumes can be steered over a maximum volumetric region while the ultrasound probe is held stationary at a chosen acoustic window. This enables the user to find the best acoustic region for viewing the maximum volumetric region,

then to interrogate the region by steering live 3D subvolumes over it. In one embodiment the subvolumes are steerable over predetermined incremental positions. In another embodiment the subvolumes are continuously steerable over the maximum volumetric region. A first display embodiment is described with concurrent 3D and 2D images that enable the user to intuitively sense the location of the subvolume. Another display embodiment is described which enables the user to select from among a number of desirable viewing orientations.

In the drawings:

FIGURE 1 illustrates an ultrasonic diagnostic imaging system constructed in accordance with the principles of the present invention.

FIGURE 2 illustrates in block diagram form the architecture of an ultrasound system constructed in accordance with the principles of the present invention.

FIGURE 3 illustrates in block diagram form the major elements of a 3D probe and beamformer in one embodiment of the present invention.

FIGURE 4 illustrates a volumetric region which can be scanned from a two-dimensional matrix transducer.

FIGURE 5 illustrates a volumetric region encompassing the heart in an apical view.

FIGURE 6 illustrates the division of the volumetric region of FIGURES 4 and 5 into three subvolumes.

FIGURE 7 illustrates elevation planes of the subvolumes of FIGURE 6.

FIGURES 8a-8c are ultrasonic images of the three subvolumes of FIGURE 6.

FIGURES 9a-9c illustrate the beam plane inclination used to scan the three subvolumes of FIGURES 8a-8c.

5 FIGURE 10 illustrates the multiline reception used in the acquisition of the three subvolumes of FIGURES 8a-8c.

FIGURES 11-22 are screen shots of two and three dimensional images in different orientations in accordance with the present invention; and

10 FIGURES 11a-22a illustrate the views of the heart which may be obtained with the image orientations of FIGURES 11-22.

FIGURE 23 is a block diagram illustrating the control sequence for continuous steering of a subvolume over a maximum volumetric region.

15 FIGURE 24 illustrates a subvolume repositioned by continuous steering.

Referring first to FIGURE 1, an ultrasound system constructed in accordance with the principles of the present invention is shown. The ultrasound system includes a mainframe or chassis 60 containing most of the electronic circuitry for the system. The chassis 60 is wheel-mounted for portability. An image display 62 is mounted on the chassis 60. Different imaging probes may be plugged into three connectors 64 on the chassis. The chassis 60 includes a control panel with a keyboard and controls, generally indicated by reference numeral 66, by which a sonographer operates the ultrasound system and enters information about the patient or the type of examination that is being conducted. At the back of the control panel 66 is a touchscreen display 68 on which programmable softkeys are displayed for specific control function as described below. The sonographer selects a softkey on the touchscreen

20
25
30
35

display 18 simply by touching the image of the softkey on the display. At the bottom of the touchscreen display is a row of buttons, the functionality of which varies in accordance with the softkey labels on the touchscreen immediately above each button.

A block diagram of the major elements of an ultrasound system of the present invention is shown in FIGURE 2. An ultrasound transmitter 10 is coupled through a transmit/receive (T/R) switch 12 to a transducer array 14. Transducer array 14 is a two-dimensional array (matrix array) of transducer elements for performing three-dimensional scanning. The transducer array 14 transmits ultrasound energy into a volumetric region being imaged and receives reflected ultrasound energy, or echoes, from various structures and organs within the region. The transmitter 10 includes a transmit beamformer which controls the delay timing by which the signals applied to elements of the transducer array are timed to transmit beams of a desired steering direction and focus. By appropriately delaying the pulses applied to each transducer element by transmitter 10, the transmitter 10 transmits a focused ultrasound beam along a desired transmit scan line. The transducer array 14 is coupled through T/R switch 12 to an ultrasound receiver 16. Reflected ultrasound energy from points within the volumetric region is received by the transducer elements at different times. The transducer elements convert the received ultrasound energy to received electrical signals which are amplified by receiver 16 and supplied to a receive beamformer 20. The signals from each transducer element are individually delayed and then are summed by the beamformer 20 to provide a beamformed signal

that is a representation of the reflected ultrasound energy level along points on a given receive scan line. As known in the art, the delays applied to the received signals may be varied during reception of
5 ultrasound energy to effect dynamic focusing. The process is repeated for multiple scan lines to directed throughout the volumetric region to provide signals for generating an image of the volumetric region. Because the transducer array is two-
10 dimensional, the receive scan lines can be steered in azimuth and in elevation to form a three-dimensional scan pattern. The beamformed signals may undergo signal processing such as filtering and Doppler processing and are stored in an image data buffer 28
15 which stores image data for different volume segments or subvolumes of a maximum volumetric region. The image data is output from image data buffer 28 to a display system 30 which generates a three-dimensional image of the region of interest from the image data
20 for display on the image display 62. The display system 30 includes a scan converter which converts sector scan signals from beamformer 20 to conventional raster scan display signals. The display system 30 also includes a volume renderer. A
25 system controller 32 provides overall control of the system in response to user inputs and internally stored data. The system controller 32 performs timing and control functions and typically includes a microprocessor and associated memory. The system
30 controller is also responsive to signals received from the control panel and touchscreen display 36 through manual or voice control by the system user. An ECG device 34 includes ECG electrodes attached to the patient. The ECG device 34 supplies ECG waveforms
35 to system controller 32 for display during a cardiac

exam. The ECT signals may also be used during certain exams to synchronize imaging to the patient's cardiac cycle.

FIGURE 3 is a more detailed block diagram of an ultrasound system when operating with a matrix array for 3D imaging. The elements of the two-dimensional transducer array 14 of FIGURE 1 are divided into M transmit sub-arrays 30A connected to M intra-group transmit processors and N receive sub-arrays 30B connected to N intra-group receive processors. Specifically, transmit sub-arrays $31_1, 31_2, \dots, 31_M$ are connected to intra-group transmit processors $38_1, 38_2, \dots, 38_M$, respectively, which in turn are connected to channels $41_1, 41_2, \dots, 41_M$ of a transmit beamformer 40. Receive sub-arrays $42_1, 42_2, \dots, 42_N$ are connected to intra-group receive processors $44_1, 44_2, \dots, 44_N$, respectively, which, in turn, are connected to processing channels $48_1, 48_2, \dots, 48_N$ of a receive beamformer 20. Each intra-group transmit processor 38_i includes one or more digital waveform generators that provide the transmit waveforms and one or more voltage drivers that amplify the transmit pulses to excite the connected transducer elements. Alternatively, each intra-group transmit processor 38_i includes a programmable delay line receiving a signal from a conventional transmit beamformer. For example, transmit outputs from the transmitter 10 may be connected to the intra-group transmit processors instead of the transducer elements. Each intra-group receive processor 44_i may include a summing delay line, or several programmable delay elements connected to a summing element (a summing junction). Each intra-group receive processor 44_i delays the individual transducer signals, adds the delayed

signals, and provides the summed signal to one channel 48_i of receive beamformer 20. Alternatively, one intra-group receive processor provides the summed signal to several processing channels 48_i of a parallel receive beamformer. The parallel receive beamformer is constructed to synthesize several receive beams simultaneously (multilines). Each intra-group receive processor 44_i may also include several summing delay lines (or groups of programmable delay elements with each group connected to a summing junction) for receiving signals from several points simultaneously. A system controller 32 includes a microprocessor and an associated memory and is designed to control the operation of the ultrasound system. System controller 32 provides delay commands to the transmit beamformer channels via a bus 53 and also provides delay commands to the intra-group transmit processors via a bus 54. The delay data steers and focuses the generated transmit beams over transmit scan lines of a wedge-shaped transmit pattern, a parallelogram-shaped transmit pattern, or other patterns including three-dimensional transmit patterns. A system controller 32 also provides delay commands to the channels of the receive beamformer via a bus 55 and delay commands to the intra-group receive processors via a bus 56. The applied relative delays control the steering and focusing of the synthesized receive beams. Each receive beamformer channel 48_i includes a variable gain amplifier which controls gain as a function of received signal depth, and a delay element that delays acoustic data to achieve beam steering and dynamic focusing of the synthesized beam. A summing element 50 receives the outputs from beamformer channels $48_1, 48_2, \dots, 48_N$ and adds the

outputs to provide the resulting beamformer signal to an image generator 30. The beamformer signal represents a receive ultrasound beam synthesized along a receive scan line. Image generator 30
5 constructs an image of a region probed by a multiplicity of round-trip beams synthesized over a sector-shaped pattern, a parallelogram-shaped pattern or other patterns including three-dimensional patterns. Both the transmit and receive beamformers
10 may be analog or digital beamformers as described, for example, in U.S. Pat. Nos. 4,140,022; 5,469,851; or 5,345,426 all of which are incorporated by reference.

The system controller controls the timing of the
15 transducer elements by employing "coarse" delay values in transmit beamformer channels 41_i and "fine" delay values in intra-group transmit processors 38_i . There are several ways to generate the transmit pulses for the transducer elements. A pulse
20 generator in the transmitter 10 may provide pulse delay signals to a shift register which provides several delay values to the transmit subarrays 30A. The transmit subarrays provide high voltage pulses for driving the transmit transducer elements.
25 Alternatively, the pulse generator may provide pulse delay signals to a delay line connected to the transmit subarrays. The delay line provides delay values to the transmit subarrays, which provide high voltage pulses for driving the transmit transducer
30 elements. In another embodiment the transmitter may provide shaped waveform signals to the transmit subarrays 30A. Further details concerning the transmit and receive circuitry of FIGURE 3 may be found in US Pat. 6,126,602.

FIGURE 4 illustrates a two-dimensional matrix array transducer 70 which scans a volumetric region 80. By phased array operation of the transducer and imaging system described above, the matrix array can scan beams over a pyramidal volumetric region 80. The height of the pyramid from its apex to its base determines the depth of the region being imaged, which is chosen in accordance with factors such as the frequency and depth of penetration of the beams. The inclination of the sides of the pyramid are determined by the degree of steering applied to the beams, which in turn are chosen in consideration of the delays available for beam steering and the sensitivity of the transducer to off-axis (acutely inclined) beam steering.

A maximal volumetric region such as volumetric region 80 may be of sufficient size to encompass the entire heart for 3D imaging as shown in FIGURE 5, in which the heart 100 is shown being apically scanned. Three chambers of the heart 100 are shown in the heart graphic of FIGURE 5, including the right ventricle (RA), the left atrium (LA), and the left ventricle (LV). Also shown is the aorta (AO) and its aortic valve 102, and the mitral valve 104 between the LA and the LV. However the time required to scan the entire maximal volumetric region 80 to visualize the entire heart may be too slow for satisfactory real time imaging, or may take too long such that motion artifacts occur, or both. In accordance with the principles of the present invention, the maximal volumetric region is divided into subvolumes B (back), C (center) and F (front), as shown in FIGURE 6. While the volumetric region 80 may subtend an angle in the azimuth (AZ) direction of 60°, for instance, the subvolumes will subtend lesser angles.

In the embodiment of FIGURE 6 the subvolumes each subtend an angle of 30° . This means that, for the same beam density and depth, each subvolume can be scanned in half the time of the entire volumetric region 80. This will result in a doubling of the real time frame rate of display. The subvolumes can be made contiguous or overlapping. For example, if the angle of the maximal volumetric region were 90° , three contiguous subvolumes of 30° each might be employed. Alternatively, for a 60° maximal volumetric region, three 20° subvolumes could be used for an even higher frame rate. In the embodiment of FIGURE 6 the B and F subvolumes are contiguous in the center of the maximal volumetric region 80 and the C subvolume is centered at the center of the region 80. As explained below, this partitioning of the region 80 provides a constant, easy-to-comprehend reference of the 3D volumes for the benefit of the sonographer.

In accordance with a further aspect of the present invention, each of the subvolumes is chosen by toggling a single control on the touchscreen 68 of the ultrasound system, enabling the sonographer to move through the sequence of subvolumes without moving the probe. In cardiac imaging, locating an acceptable acoustic window of the body is often challenging. Since the heart is enclosed by the ribs, which are not good conveyors of ultrasound, it is generally necessary to locate an aperture through the ribs or beneath the ribs for the probe. This is particularly difficult in 3D imaging, as the beams are steered in both elevation (EL) and azimuth. Once the sonographer finds an acceptable acoustic window to the heart, it is of considerable benefit to hold the probe in contact with the window during scanning. In an embodiment of the present invention the

sonographer can locate the acoustic window while scanning the heart in 2D in the conventional manner. Once an acceptable acoustic window has been found during 2D imaging, the system is switched to 3D
5 imaging with the touch of a button; there is no need to move the probe. The user can then step from the back to the center to the front subvolume with a single button, observing each subvolume in live 3D
10 imaging and without the need to move the probe at any time.

FIGURE 7 illustrates the profiles of each azimuthal center plane of each of the B, C, and F subvolumes formed as described above. When the three subvolumes are formed as illustrated in FIGURE 6,
15 these center planes uniquely correspond to each subvolume: the center plane of the back subvolume B is a right triangle inclined to the left, the center plane of the front subvolume F is a right triangle inclined to the right and the center plane of the
20 center subvolume C is symmetrical. As illustrated below, the shapes of these planes enable the sonographer to immediately comprehend the subvolume being viewed. FIGURES 8a, 8b, and 8c illustrate
25 screen shots taken of a display screen 62 when the three subvolumes are displayed. In these and subsequent drawings the images have undergone black/white reversal from their conventional ultrasound display format for clarity of
30 illustration. As just explained, the F subvolume in FIGURE 8a is seen to be inclined to the right, the B subvolume in FIGURE 8c is inclined to the left, and the C subvolume in FIGURE 8B is seen to be
symmetrically balanced.

As a different subvolume is selected for
35 viewing, the inclination of the beam planes of the

transmit and receive beams is changed to acquire the desired subvolume. FIGURE 9a is a view normal to the plane of the matrix transducer which illustrates the beam scanning space in the theta-phi plane for 3D

5 scanning. In this beam scanning space a row of beams in a horizontal line across the center of the aperture 90 extends normal to the face of the transducer in elevation but are steered progressively from left to right from -45° to 0° (in the center) to

10 $+45^\circ$ in azimuth, as the transducer is operated as a phased array transducer. Similarly, a column of beams in a vertical line down the center of the aperture 90 extends normal to the face of the transducer in azimuth but are steered progressively

15 from -45° to 0° (in the center) to $+45^\circ$ in elevation from the bottom to the top of the array. In FIGURE 9a a group of beam planes inclined from 0° to $+30^\circ$ is used to scan the front subvolume F. Each elevational beam plane extends from -30° to $+30^\circ$ in azimuthal

20 inclination in this illustrated embodiment. When probe is stepped to scan the center subvolume C the transmit beam planes extend from a -15° inclination to a $+15^\circ$ inclination as shown in FIGURE 9b. When the probe is stepped to scan the back subvolume B the

25 transmit beam planes used are those inclined from -30° to 0° as shown in FIGURE 9c. In each of these illustrations the beams in the beam plane are symmetrically inclined in azimuth from -30° to $+30^\circ$. However in a constructed embodiment other

30 inclinations could be used and/or the subvolume could be inclined asymmetrically to the left or right in azimuth as desired. Since the selection of the transmit and receive beam inclinations is done electronically by the system controller and the

transmitter, there is again no need to move the probe from its acoustic window when making this change.

5 In a linear array embodiment, in which all of the beams are normal to the plane of the transducer, the transmit and receive apertures would be stepped along the array to transmit and receive spatially different subvolumes.

10 In a constructed embodiment 4X multiline is used to increase the beam density, which means that four receive beams are formed in response to each transmitted beam. FIGURE 10 shows a typical 4X multiline pattern, in which each transmit beam, T1 and T2 in this illustration, results in four receive beams represented by the four x's located around each transmit beam.

15 In accordance with another aspect of the present invention, each 3D subvolume display is also accompanied by two 2D images which help the sonographer orient the image being viewed. As previously explained, the sonographer begins by scanning the heart in 2D, moving the probe until an appropriate acoustic window is found. In this survey mode of operation, the matrix array probe is transmitting and receiving a single 2D image plane oriented normal to the center of the array. Once the acoustic window is found the 2D image is the center image plane of the maximal volumetric region 80 of FIGURE 6. The user then touches the "3D" button on the touchscreen 68 to switch to 3D imaging, and a single 3D image appears on the screen. The user can then touch the "Image" button on the touchscreen to see a number of display options. In a constructed embodiment one of these buttons has three triangles on it ("3Δ"), and when this button is touched the display screen 62 shows the three images shown in

20

25

30

35

FIGURE 11, which is a B/W inverted actual screen shot. At the top center of the screen is the front subvolume F 3D image. At the lower left of the screen is a 2D image 110 of the face 110' of the subvolume F. When the three subvolumes are chosen as shown in FIGURE 6, the image 110 is also the center image of the maximal volumetric region 80 and is also the guiding 2D azimuthal image plane used in the initial 2D survey mode. On the lower right side of the display is a 2D image 112 of the center cut plane of the subvolume F, which is an elevation reference image in the illustrated embodiment. It is seen that the image 112 bears the distinctive profile of the front subvolume discussed in conjunction with FIGURE 7. Thus these orthogonal 2D images 110 and 112 provide familiar 2D assistance to the user in comprehending the orientation of the 3D subvolume image F. The subvolume F is the subvolume subtended by the dashed lines extending from the matrix array transducer 70 through the heart graphic 100 in FIGURE 11a.

Also on the touchscreen 68 at this time is a button denoted "Front", for the F image view. When the user touches this button, it changes to a "Center" button and the display of FIGURE 12 appears on the display screen 62. The display has now switched to the 3D center subvolume C at the top of the screen. The 2D image 110 is an image of the center cut plane of this subvolume from the near side to the far side of the subvolume C as indicated by 110'. The symmetrical 2D image 114 is the distinctive symmetrical cut plane through the center of the subvolume from left to right. The subvolume C is that subtended by the dashed lines extending from

the matrix transducer 70 in FIGURE 12a through the heart graphic 100.

When the Center button is touched again it changes to read "Back" and the image display of
5 FIGURE 13 appears with the 3D subvolume B shown at the top of the display. The 2D image 110 is still the center plane of the maximal volume in this embodiment (FIGURE 6), and is also the face plane on
10 the right side 110' of the subvolume B. The distinctive center cut plane from left to right through the subvolume B is shown at 116. The volumetric subregion shown in this display is the region subtended by the dashed lines extending from
15 the matrix transducer 70 in FIGURE 13a through the heart graphic 100.

Continual touching of the Front/Center/Back button will continue to switch the display through these three image displays. The sequence of the
20 images may be selected by the system designer. For instance, in a constructed embodiment, the initial image display is of the Back subvolume and the selection switch toggles the display through the Back/Center/Front views in sequence. Thus, the sonographer can visualize the entire heart in live 3D
25 by stepping through the three high frame rate subvolumes in succession.

In each of the image displays of FIGURES 11-13 the viewing perspective of the live 3D subvolume can be adjusted by the user. The images initially appear
30 in the perspectives seen in the drawings but can then be changed by the user by rotating the trackball on the control panel 66. As the trackball is manipulated the 3D subvolumes appear to rotate in the display, enabling the user to view the anatomy in
35 each subvolume from the front, back, sides, or other

rotated viewing perspectives. This is accomplished by changing the dynamic parallax rendering look direction in response to movement of the trackball.

In accordance with a further aspect of the present invention, the 3D image orientation may be varied in accordance with the preferences of the user. For example, adult cardiologists usually prefer to visualize an apical view of the heart with the apex of the heart and the apex of the image both at the top of the screen as shown in the preceding FIGURES 11-13. In this orientation the heart is essentially seen in an upside down orientation. Pediatric cardiologists, on the other hand, will usually prefer to view both the apex of the heart and the apex of the image at the bottom of the screen, in which the heart is viewed in its right side up anatomical orientation. To enable each user to view the heart as he or she is accustomed, an embodiment of the present invention will have an Up/Down Invert button. In the embodiment described below the ultrasound system also has a Left/Right Reversal button which is also described.

When the user touches the Up/Down Invert button on the touchscreen 68, the order in which the scanlines are processed for display in scan conversion and 3D rendering is reversed and the display will switch to that shown in FIGURE 14. In this view the 3D subvolume F has become inverted with the apex of the heart at the bottom of the image as illustrated by the matrix array 70 and the heart graphic 100 in FIGURE 14a. The center plane 210 of the maximal volumetric region 80 has also been correspondingly inverted and still illustrates the view of the face 210' of the inverted subvolume F. Likewise, the distinctive center cut plane 212 of the

subvolume F is also inverted. Inversion of the image also reverses the left-right direction of the images on the display screen so that the original sense of the anatomy is retained in the images. In the
5 illustrated embodiment inversion (and reversal, as discussed below) will cause the "Back" subvolume to become the "Front" subvolume, and *vice versa*.

Touching the touchscreen button now reading Front will cause the button to change to Center and the display to switch to the inverted 3D center
10 subvolume C as shown in FIGURE 15. The 2D front-to-back center plane 210 of the subvolume C is inverted, as is the distinctive left-to-right cut plane 212. The subvolume C is that acquired between the dashed
15 lines extending from the matrix array transducer 70 through the heart graphic 100 in FIGURE 15a.

Touching the touchscreen button again will cause the button to change to Back and the display to change to that shown in FIGURE 16. The inverted 3D
20 subvolume B is that acquired as illustrated by the dashed lines extending from the matrix transducer 70 through the heart graphic 100 in FIGURE 16a. The 2D center plane 210 is the side face 210' of the inverted subvolume in this embodiment, and the
25 distinctive cut plane 212 of the subvolume B is also inverted.

In accordance with a further aspect of the present invention, the left-right direction of the 3D images can also be reversed. When the Left/Right
30 Reversal button on the touchscreen 68 is touched, the order of the scanlines used in the scan conversion and rendering display processes is reversed, causing the images to change sense from left to right. This effectively causes front to become back, and *vice*
35 *versa* for the 3D subvolumes. For instance, FIGURE 17

shows a 3D subvolume F after left/right reversal. The subvolume is viewed as if the direction of the anatomy has been reversed as illustrated by the reverse image 100' of the heart in FIGURE 17a. The center plane 210 and the distinctive cut plane 312 in
5 FIGURE 17 are correspondingly reversed in display line sequence.

Sequencing through the Front/Center/Back button sequence will next cause a reversed 3D subvolume C
10 image to appear as shown in FIGURE 18, as well as reversed center plane image 310 and left to right cut plane 312. The image reversal is indicated by the reversed heart graphic 100' in FIGURE 18a. When the touchscreen button is touched a third time a reversed
15 3D back subvolume image B appears as shown in FIGURE 19, together with reversed center plane image 310 and back cut plane image 312. The images are oriented as though the heart were reversed as shown in FIGURE
19a.

20 Finally, the Up/Down Inverted images can also be Left/Right Reversed as shown in FIGURES 20, 21, and 22 for the front, center and back subvolumes. In this sequence the heart appears as if both inverted and reversed as shown by the heart graphic 100' in
25 FIGURE 20a, 21a, and 22a. With both up/down inversion and left/right reversal the object being scanned can be viewed from any orientation, as if the user were scanning the anatomy from different perspectives of the body.

30 The aforescribed embodiments effectively step the sonographer through incrementally positioned subvolumes of the maximal volumetric region. Rather than step through a series of discretely positioned orientations, it may be desirable to continuously
35 change the orientation of a subvolume. This is done

by touching the "Volume Steer" button on the
touchscreen 68 when the user is in the 3D mode. In
the volume steer mode the user can manipulate a
continuous control on the control panel 66 such as a
5 knob or trackball to sweep the displayed volume back
and forth. In a constructed embodiment one of the
knobs below the touchscreen 68 is used as the volume
steer control, and a label on the touchscreen above
the knob identifies the knob as the volume steer
10 control. When the system enters the volume steer
mode, the 3D subvolume shown on the screen can be
reoriented with the control knob. When the volume
steer knob is turned to the right the displayed
subvolume appears to swing to the right from its
15 apex, and when the knob is turned to the left the
displayed subvolume appears to swing to the left. A
subvolume can be steered in this manner in inverted,
uninverted, reversed or unreversed viewing
perspective. The motion appears continuous,
20 corresponding to the continuous motion of the knob.

The control sequence for this continuous mode of
volume steering is shown in the flowchart of FIGURE
23. While the system is in this mode the system
controller is continually monitoring any change in
25 the volume steer knob. If no movement is sensed,
this monitoring continues as shown in step 501. If a
change in the knob position is sensed ("Yes"), the
controller checks in step 502 to see if the subvolume
is at a limit of the maximal volumetric region over
30 which volume steering is permitted (e.g., in contact
with a side of maximal volume 80.) If the subvolume
has been steered to its limit, the system goes back
to monitoring for a change in knob position, as only
a knob change in the other direction will swing the
35 subvolume. If a limit position has not been reached,

the beam steering angles for the transmit and receive beamformers are incremented in accordance with the change in knob position to steer the volume in the slightly different orientation in step 503. This

5 volume geometry change is communicated to the scan converter of the display system in step 503 so that the newly acquired volumetric images will be shown in their new orientation. The beamformer controller computes the first beam position of the new

10 volumetric orientation and the stop and start orientations of the beams in step 504. The parameters for scan conversion to the new orientation are reset in step 505. The new beam parameters for the transmit and receive beamformers are set in step

15 506. The system then commences to acquire and display the 3D subvolume in its new orientation such as that shown in the screen shot of FIGURE 24, and the system controller resumes monitoring of the volume steer control knob for a subsequent change.

20 With this mode of operation the sonographer can electronically sweep a 3D subvolume back and forth over the range limits of the maximal volumetric region to acquire high frame rate 3D images within the maximal volumetric region without the need to

25 move the probe from its acoustic window. In a constructed embodiment subvolumes subtending angles as great as 57° have been swept over a maximal volumetric region subtending as much as 90° .

WHAT IS CLAIMED IS:

1. An ultrasonic diagnostic imaging system for three dimensional imaging comprising:

5 a matrix array transducer which is operable to scan electronically steerable beams over a volumetric region of a body;

10 an image processor coupled to the matrix array transducer for producing live 3D images of the volumetric region;

a display coupled to the image processor which displays a live 3D image; and

15 a user control, coupled to the image processor, and operable by a user to invert the live 3D image on the display.

2. The ultrasonic diagnostic imaging system of Claim 1, wherein the volumetric region comprises anatomy; and

20 wherein the user control is operable by the user to invert the anatomy as seen in the live 3D image.

3. The ultrasonic diagnostic imaging system of Claim 1, wherein the volumetric region comprises anatomy having a top, a bottom, a left side, and a right side when viewed from a given viewing perspective;

wherein the display displays the live 3D image in a given display format; and

30 wherein the user control is operable by the user to invert both the display format and the anatomy as seen in the live 3D image.

4. The ultrasonic diagnostic imaging system of Claim 3, wherein the top of the anatomy as seen on

35

the display prior to inversion appears at the bottom of the image after inversion, the bottom of the anatomy as seen on the display prior to inversion appears at the top of the image after inversion, the left side of the anatomy as seen on the display prior to inversion appears at the right side of the image after inversion, and the right side of the anatomy as seen on the display prior to inversion appears at the left side of the image after inversion.

10

5. The ultrasonic diagnostic imaging system of Claim 3, wherein the top of the anatomy as seen at the bottom of the image on the display prior to inversion appears at the top of the image after inversion, and the bottom of the anatomy as seen on the top of the image on the display prior to inversion appears at the bottom of the image after inversion.

20

6. The ultrasonic diagnostic imaging system of Claim 3, wherein the display format comprises a sector format.

25

7. The ultrasonic diagnostic imaging system of Claim 1, wherein the image processor further comprises an image processor for producing a 2D image of a plane of the volumetric region;

30

wherein the display further comprises a display which displays the 2D image concurrently with the live 3D image;

wherein the user control is operable to simultaneously invert both the live 3D image and the 2D image on the display.

8. The ultrasonic diagnostic imaging system of Claim 1, further comprising a second user control, coupled to the image processor, and operable by a user to reverse the left-right appearance of the live 3D image on the display.

9. The ultrasonic diagnostic imaging system of Claim 8, wherein the second user control is further operable to simultaneously effect both a left-right reversal and a front-back reversal of the live 3D image on the display.

10. A method for changing the orientation of a live 3D ultrasound image comprising:
acquiring a live 3D ultrasound image with a matrix array transducer;
displaying the live 3D image in a given orientation on a display;
actuating a user control to invert the live 3D image on the display; and
displaying the live 3D image on the display in an orientation which is inverted with respect to the given orientation.

11. The method of Claim 10, further comprising actuating a second user control to reverse the left-right appearance of the live 3D image on the display; and
wherein displaying comprises displaying the live 3D image on the display in an orientation which is inverted and reversed with respect to the given orientation.

12. An ultrasonic diagnostic imaging system for three dimensional imaging comprising:

a matrix array transducer which is operable to scan electronically steerable beams over a volumetric region of a body and receive scanlines in response to the beam scanning;

5 a volume rendering image processor coupled to the matrix array transducer which processes received scanlines in a given order to produce live 3D images of the volumetric region in a given orientation;

10 a display coupled to the image processor which displays the live 3D images; and

a user control, coupled to the volume rendering image processor, and operable by a user to cause the received scanlines to be processed in a reversal of the given order,

15 wherein actuation of the user control causes the live 3D images on the display appear in an inverted orientation.

20 13. The ultrasonic diagnostic imaging system of Claim 12, further comprising:

25 a scan converter coupled to the matrix array transducer and responsive to the user control which processes received scanlines in a given order to produce a 2D image of a plane of the volumetric region in a given orientation;

wherein the display is coupled to the scan converter for display of a 2D image; and

30 wherein actuation of the second user control causes the scan converter to process received scanlines in a reversal of the given order and the 2D image on the display to appear in an inverted orientation.

35 14. The ultrasonic diagnostic imaging system of Claim 11, further comprising:

a second user control, coupled to the volume rendering image processor, and operable by a user to cause the received scanlines to be processed in a reversal of the given order,

5 wherein actuation of the second user control causes the live 3D images on the display appear in a reversed left-right orientation.

10 15. The ultrasonic diagnostic imaging system of Claim 14, further comprising:

 a scan converter coupled to the matrix array transducer and responsive to the second user control which processes received scanlines in a given order to produce a 2D image of a plane of the volumetric region in a given orientation;

15 wherein the display is coupled to the scan converter for display of a 2D image; and

 wherein actuation of the second user control causes the scan converter to process received scanlines in a reversal of the given order and 2D image on the display to appear in a reversed left-right orientation.

20

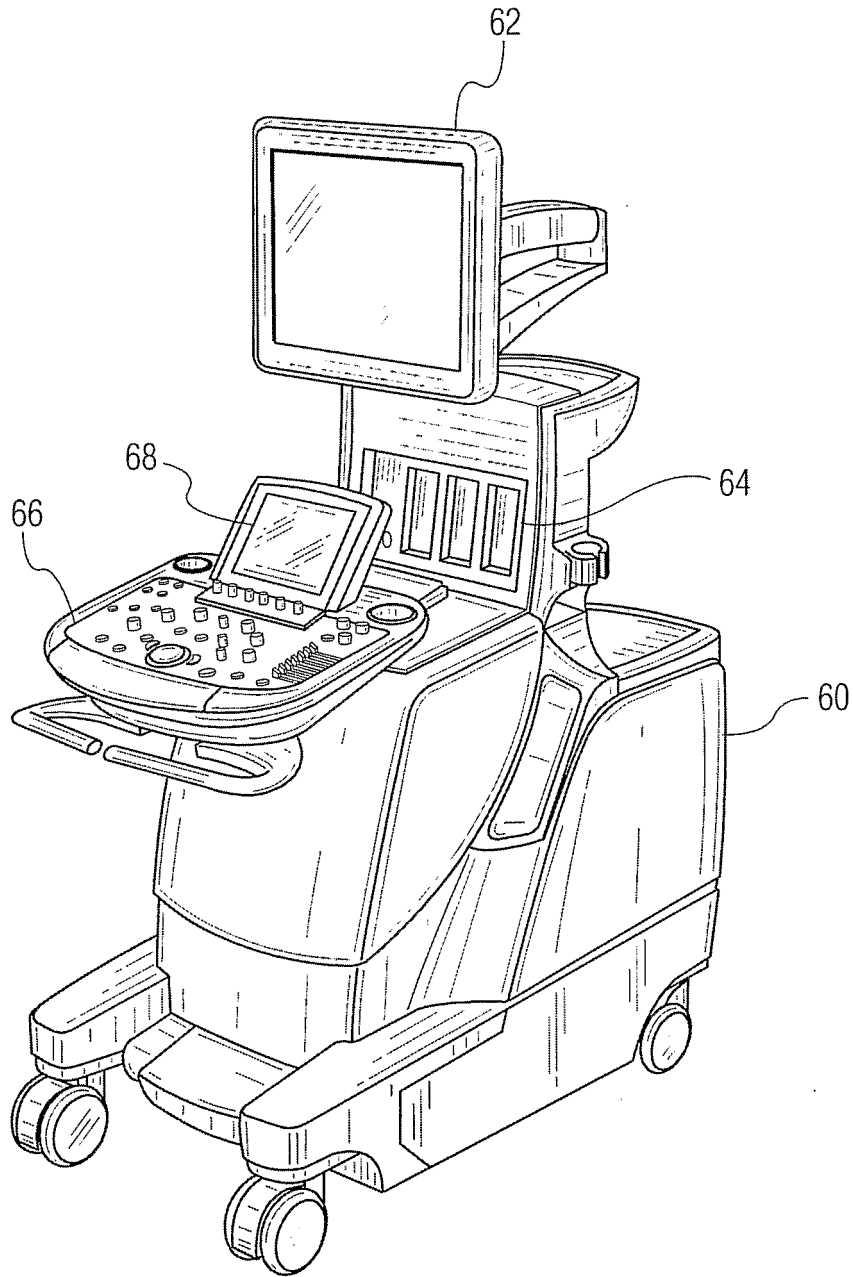

FIG. 1

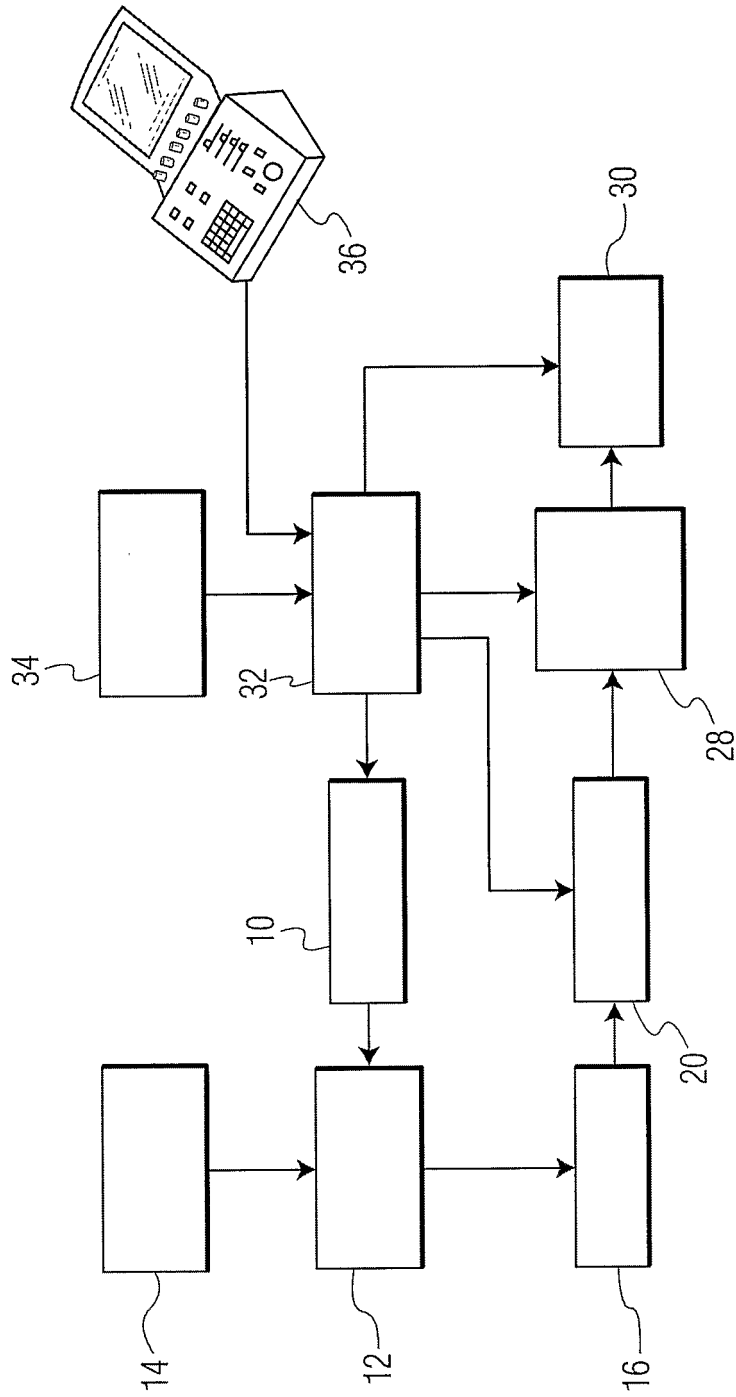

FIG. 2

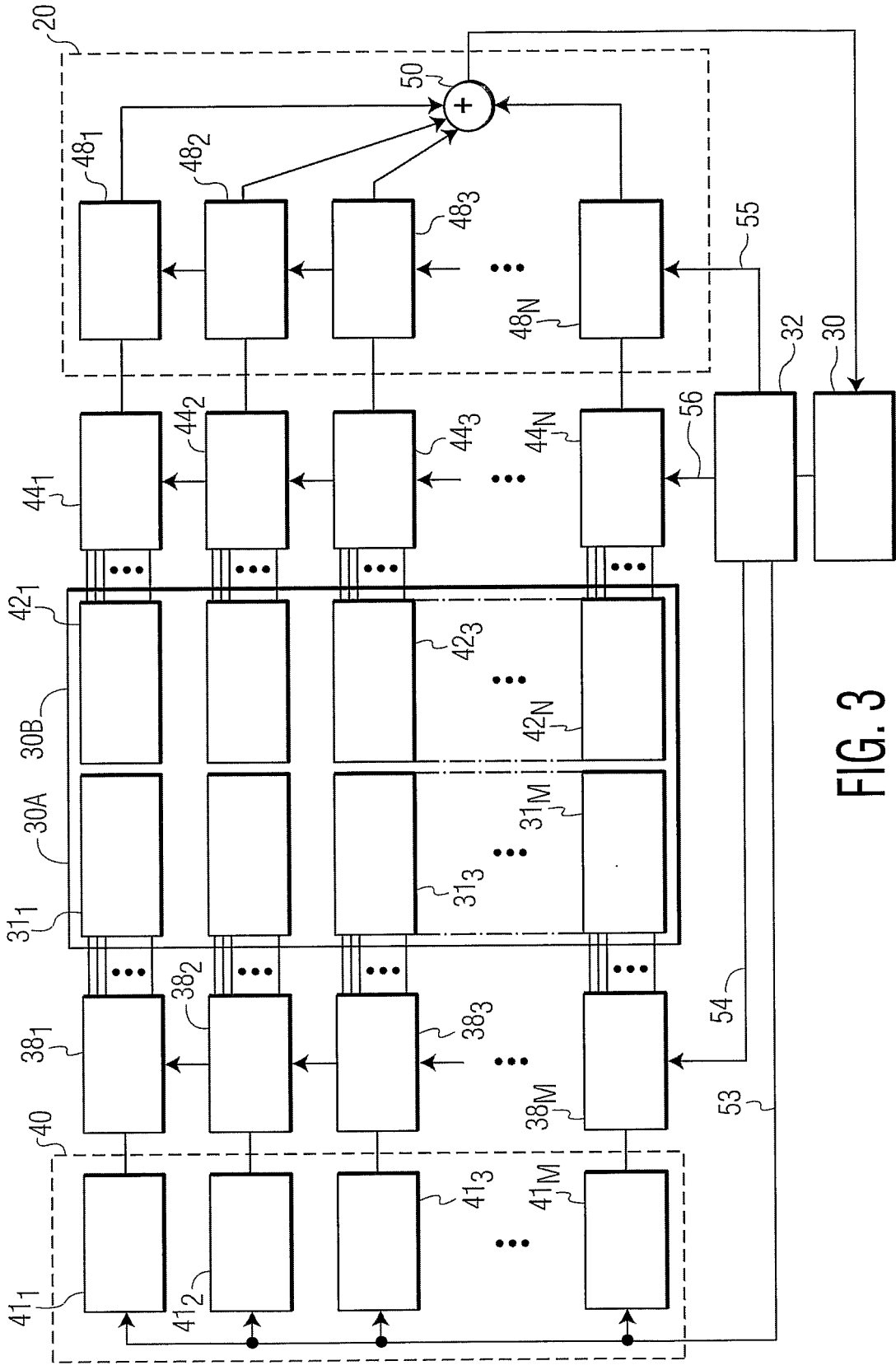

FIG. 3

4/28

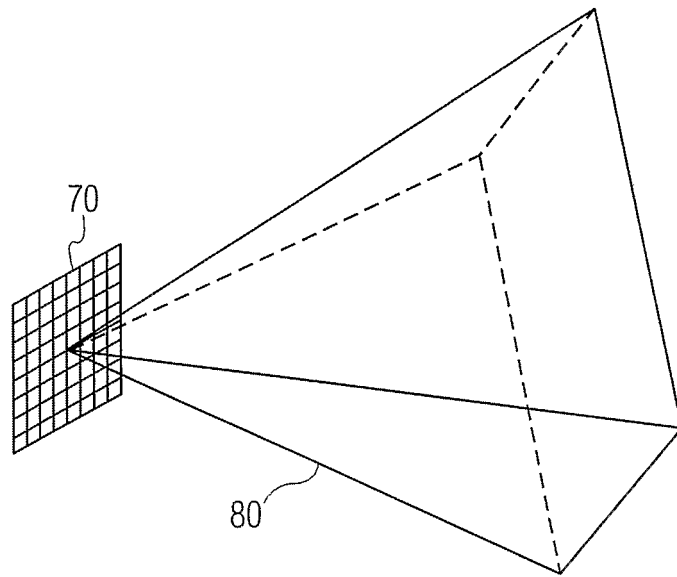

FIG. 4

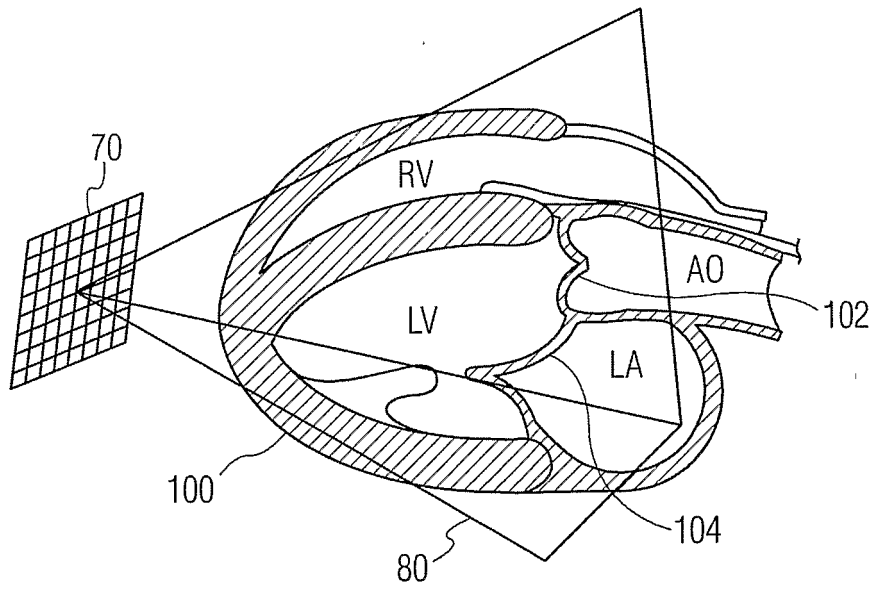

FIG. 5

5/28

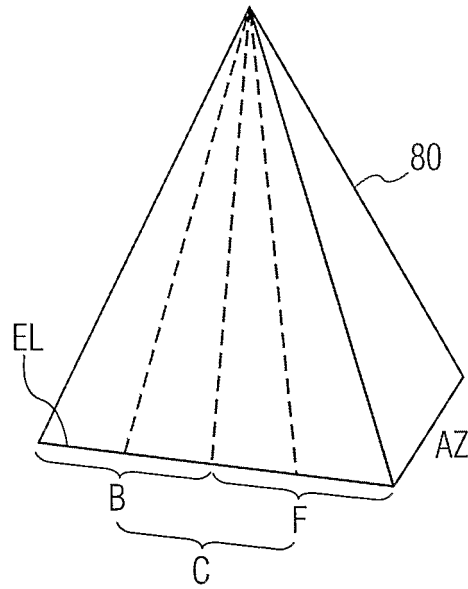

FIG. 6

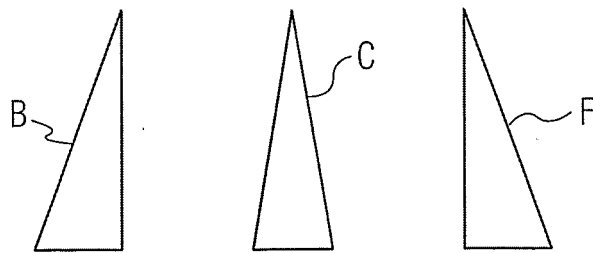

FIG. 7

6/28

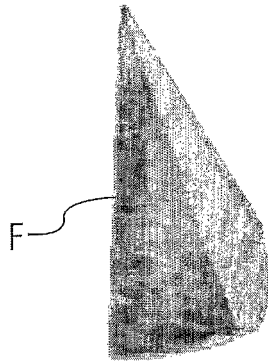

FIG. 8a

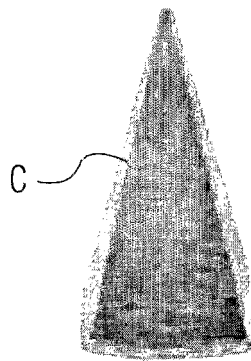

FIG. 8b

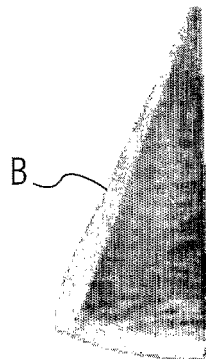

FIG. 8c

7/28

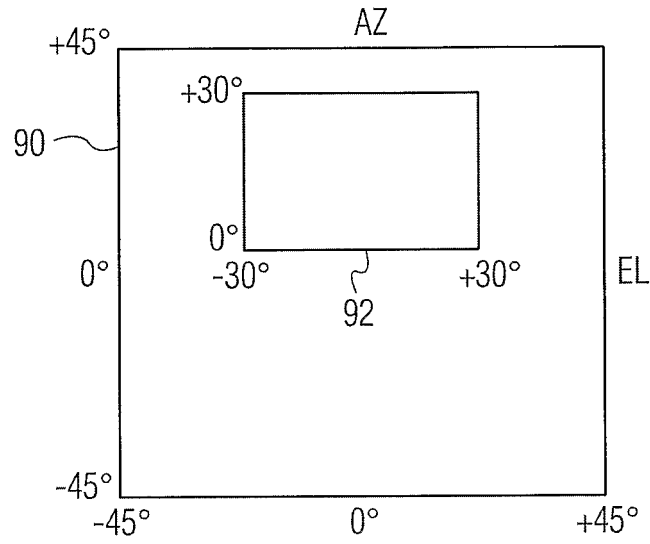

FIG. 9a

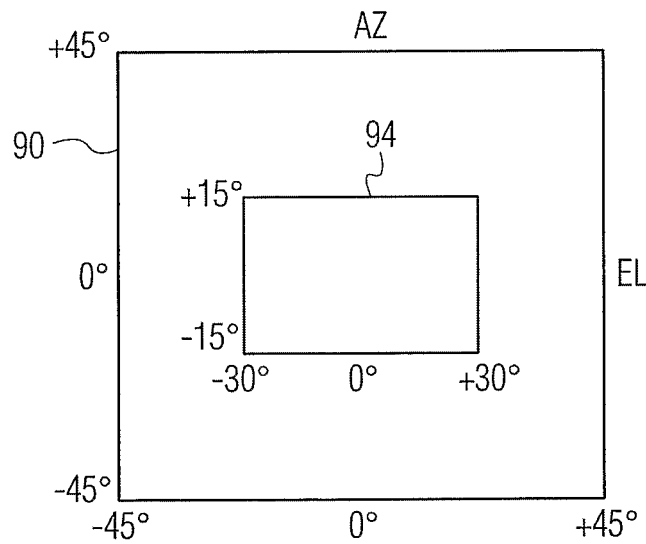

FIG. 9b

8/28

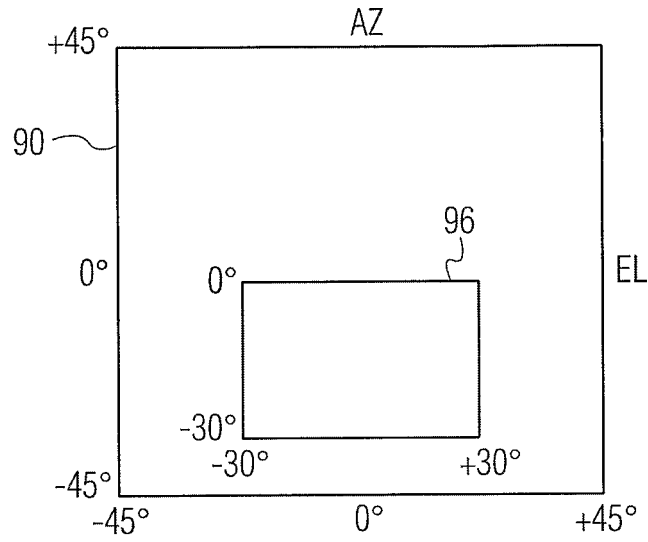

FIG. 9c

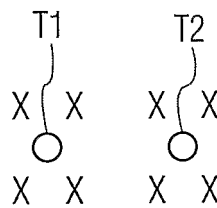

FIG. 10

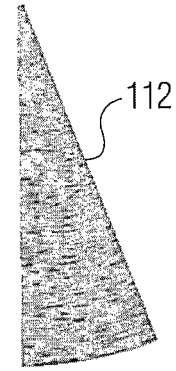
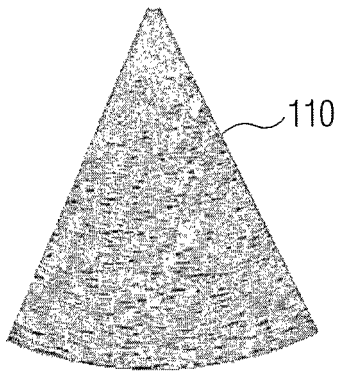
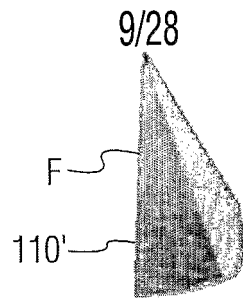

FIG. 11

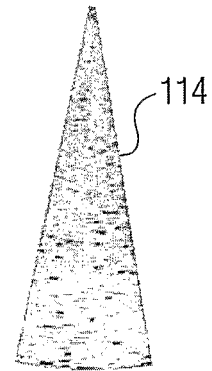
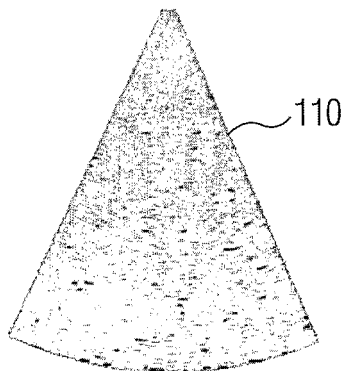
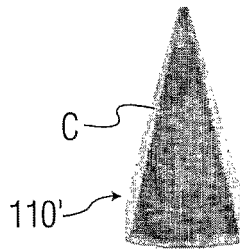

FIG. 12

10/28

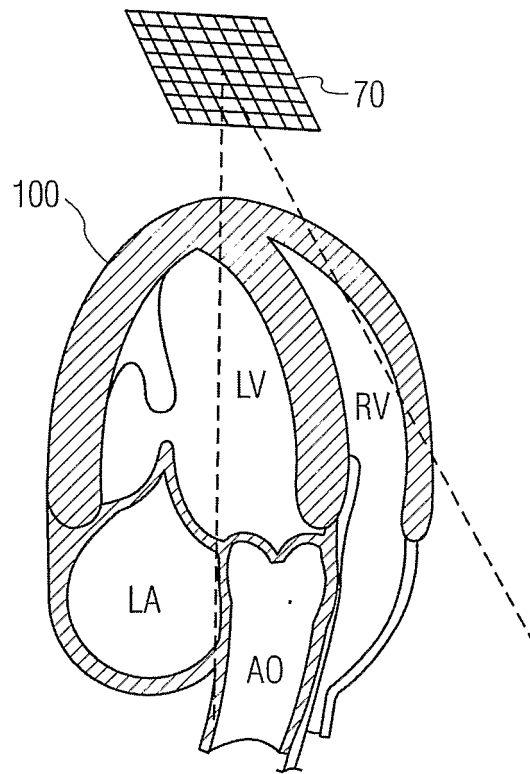

FIG. 11a

11/28

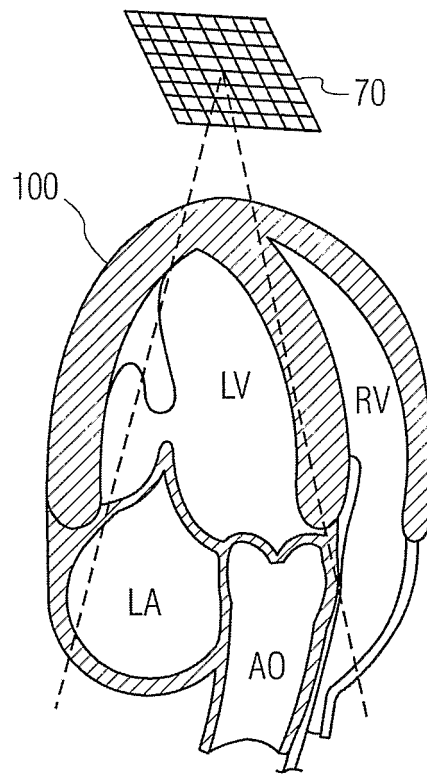

FIG. 12a

12/28

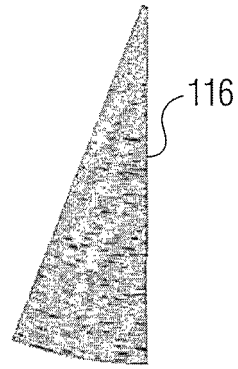
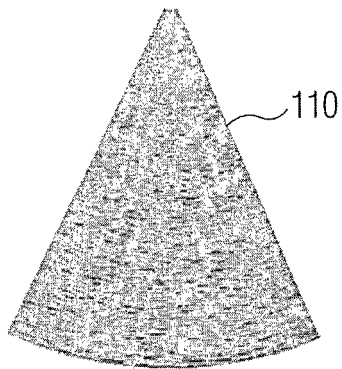
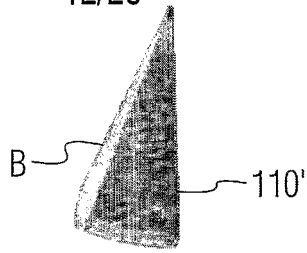

FIG. 13

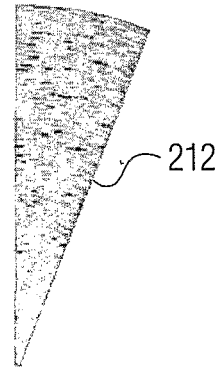
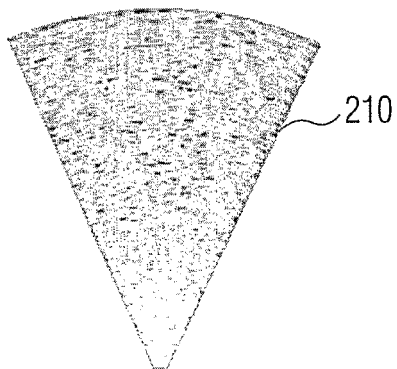
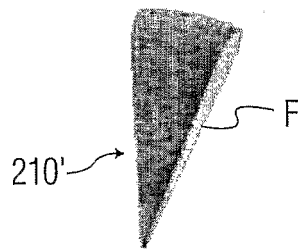

FIG. 14

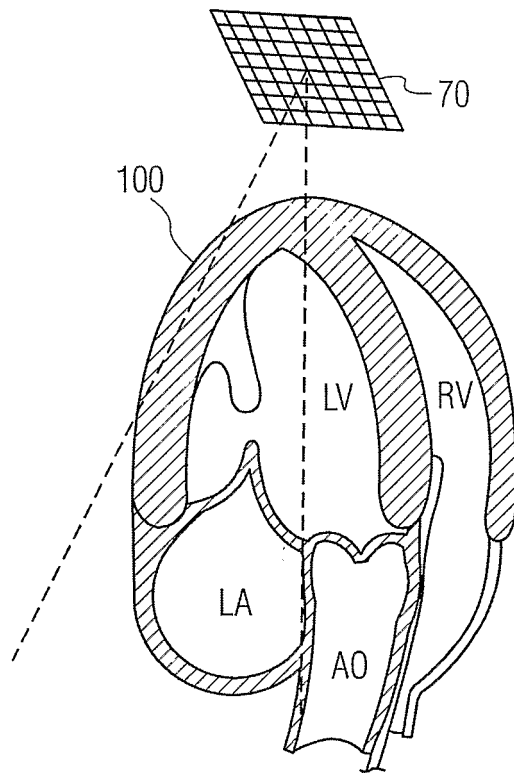

FIG. 13a

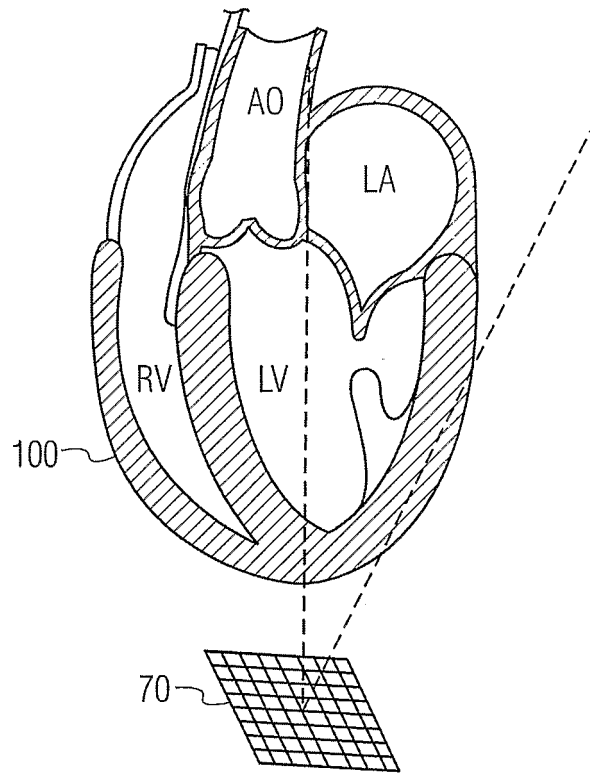

FIG. 14a

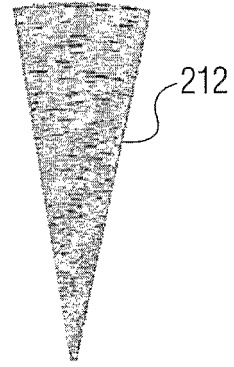
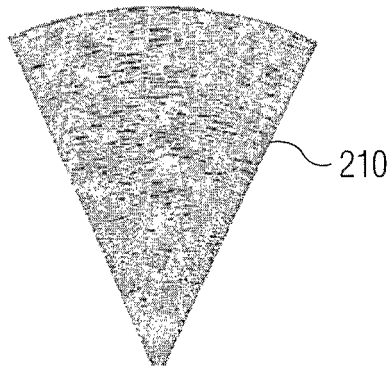
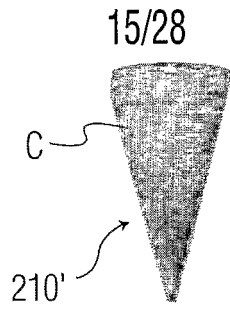

FIG. 15

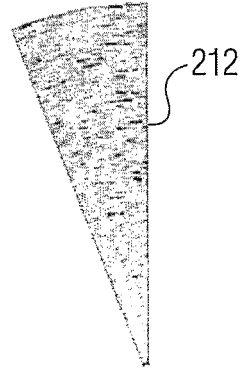
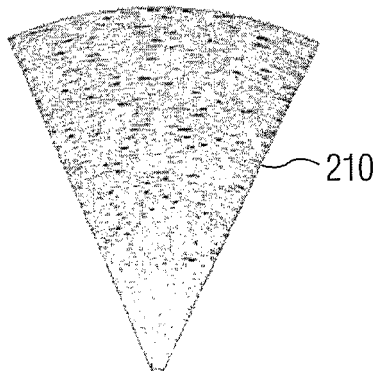
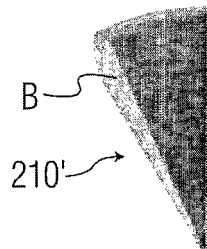

FIG. 16

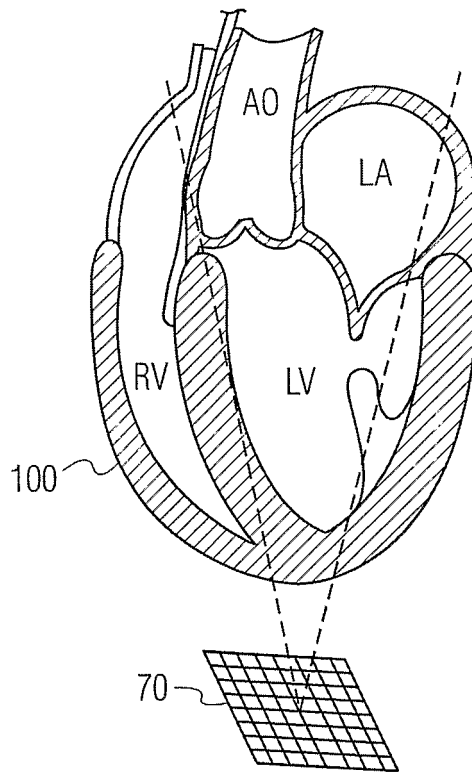

FIG. 15a

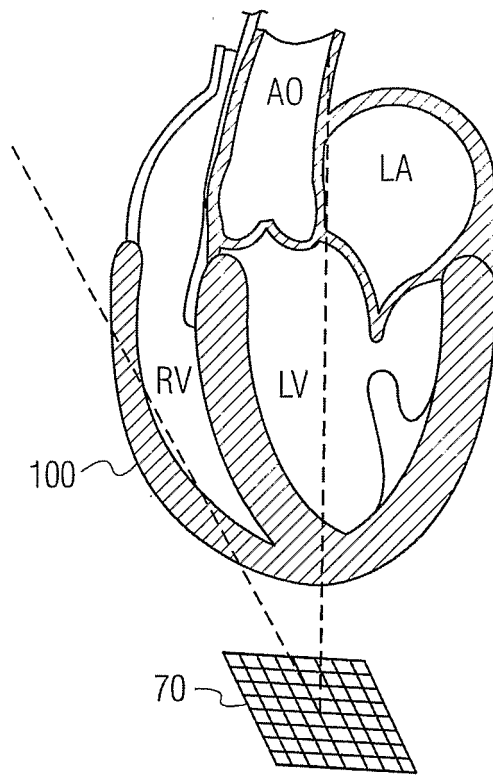

FIG. 16a

18/28

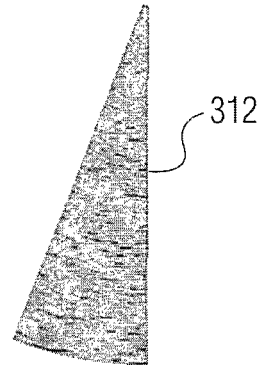
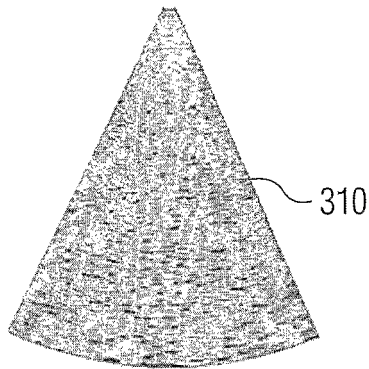
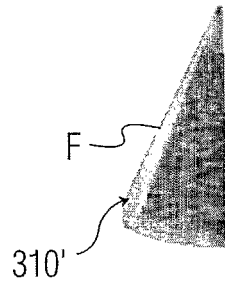

FIG. 17

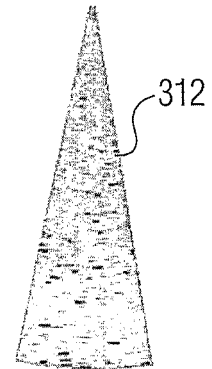
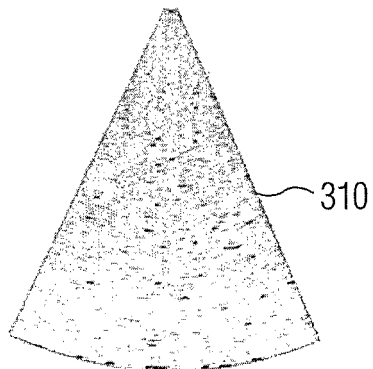
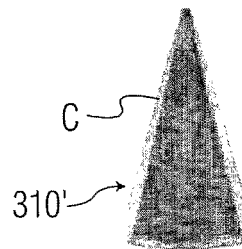

FIG. 18

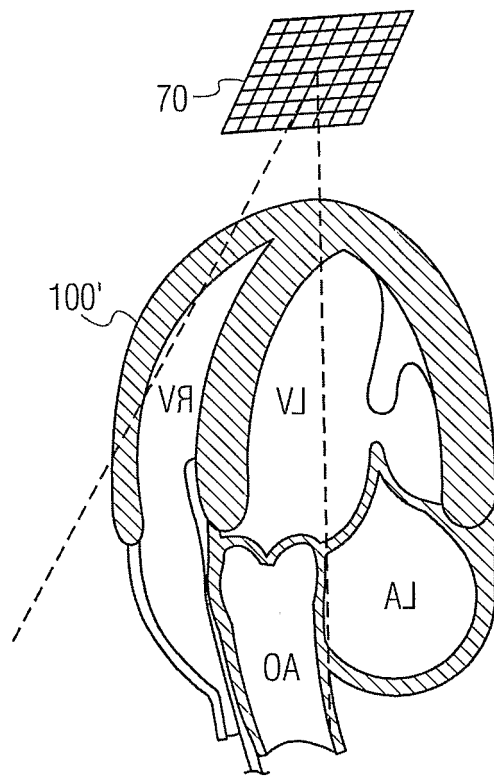

FIG. 17a

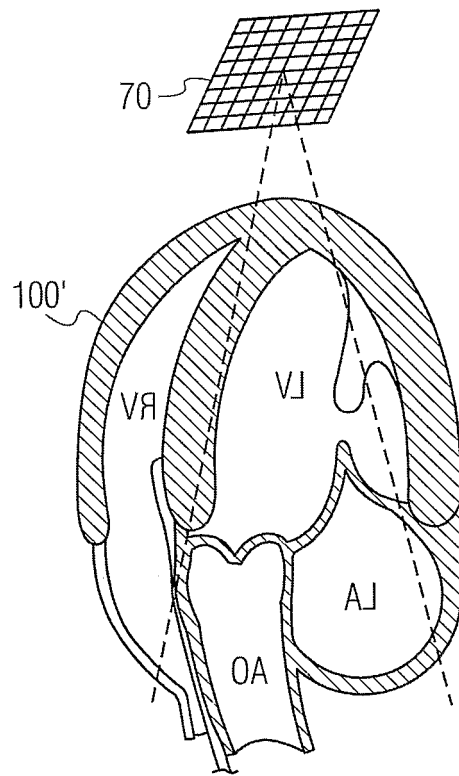

FIG. 18a

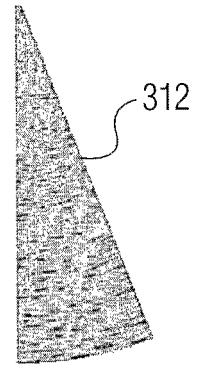
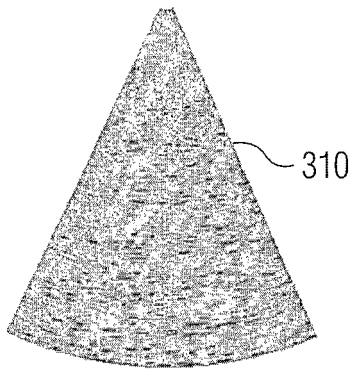
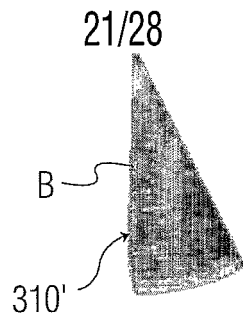

FIG. 19

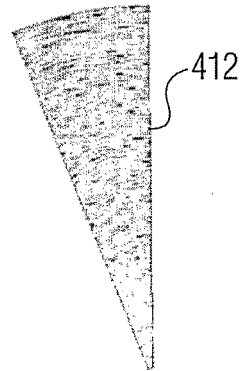
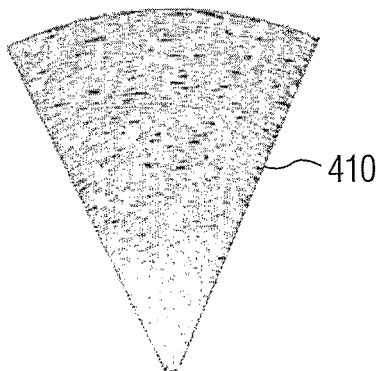
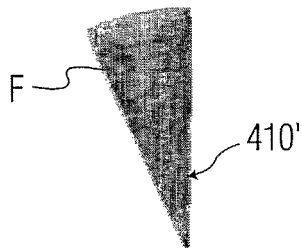

FIG. 20

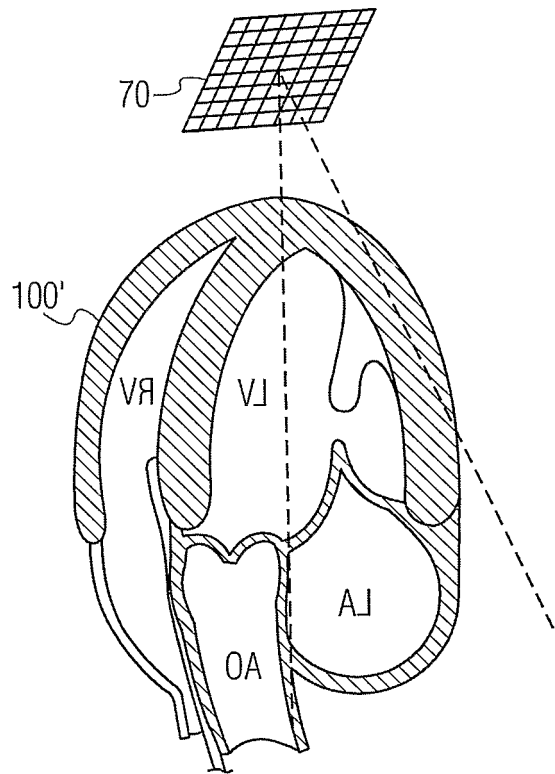

FIG. 19a

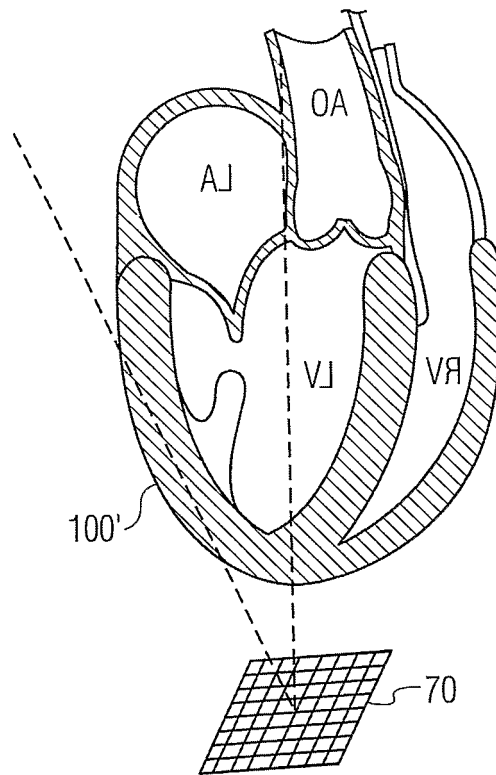

FIG. 20a

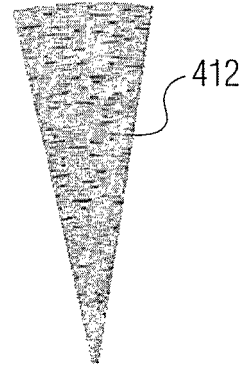
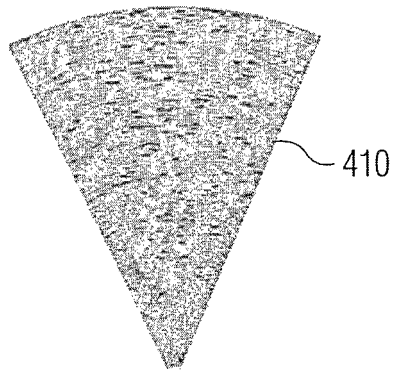
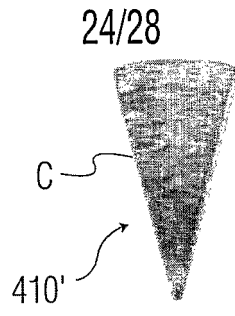

FIG. 21

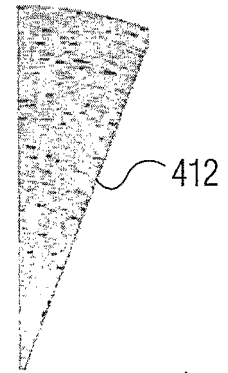
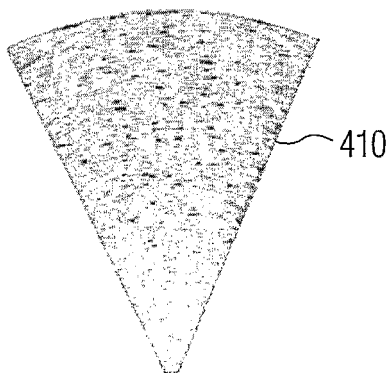
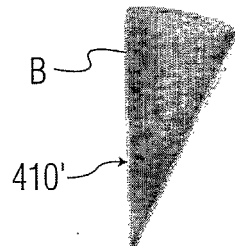

FIG. 22

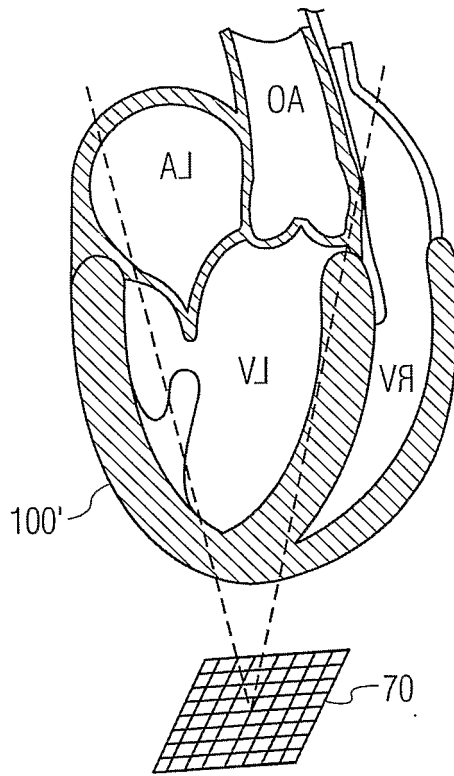

FIG. 21a

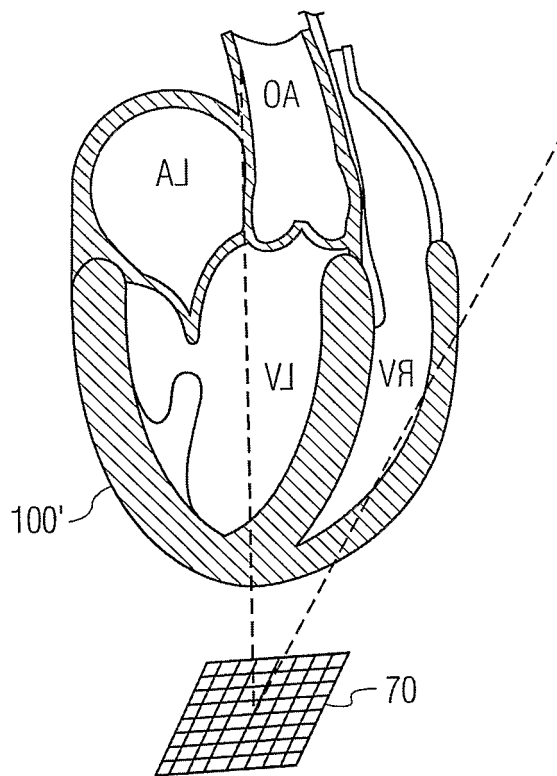

FIG. 22a

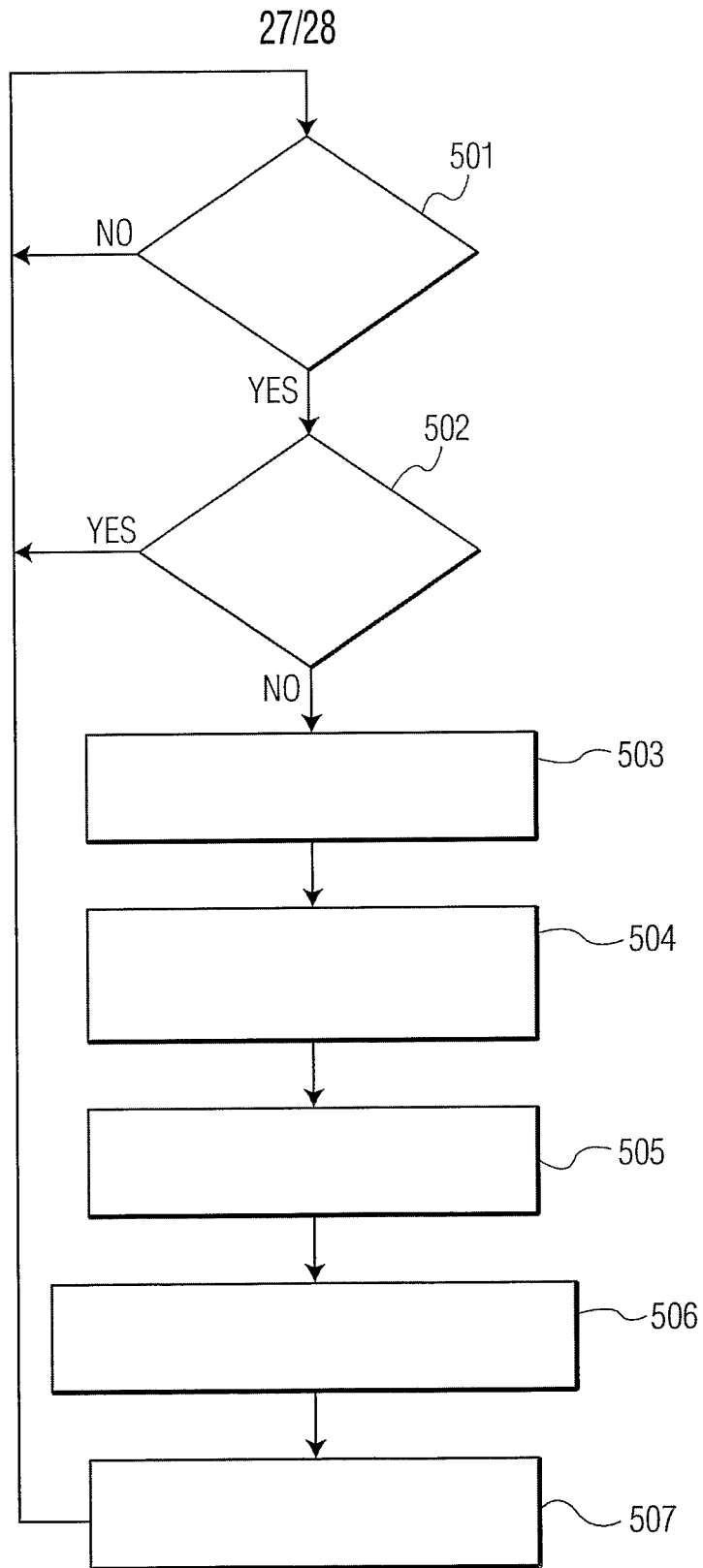

FIG. 23

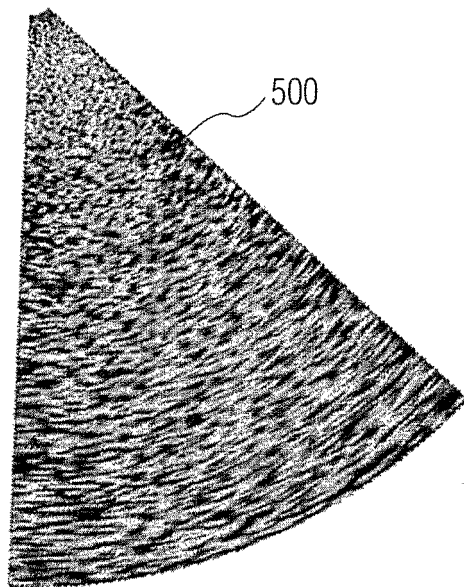

FIG. 24

INTERNATIONAL SEARCH REPORT

International Application No
/IB2005/053249

A. CLASSIFICATION OF SUBJECT MATTER A61B8/14 G01S15/89 G01S7/52				
According to International Patent Classification (IPC) or to both national classification and IPC				
B. FIELDS SEARCHED				
Minimum documentation searched (classification system followed by classification symbols) A61B G01S				
Documentation searched other than minimum documentation to the extent that such documents are included in the fields searched				
Electronic data base consulted during the international search (name of data base and, where practical, search terms used) EPO-Internal, PAJ				
C. DOCUMENTS CONSIDERED TO BE RELEVANT				
Category *	Citation of document, with indication, where appropriate, of the relevant passages	Relevant to claim No.		
X	WO 2004/029655 A (KONINKLIJKE PHILIPS ELECTRONICS N.V; U.S. PHILIPS CORPORATION) 8 April 2004 (2004-04-08) page 7, lines 8-26 page 10, lines 14-25 page 14, lines 19-32; figure 5 page 15, lines 6-9 page 16, line 3 - page 19, line 30; figures 11-13	1-11		
Y	page 21, line 26 - page 22, line 2 page 22, line 24 - page 24, line 3	12-15		
Y	PATENT ABSTRACTS OF JAPAN vol. 2000, no. 13, 5 February 2001 (2001-02-05) -& JP 2000 287976 A (OLYMPUS OPTICAL CO LTD), 17 October 2000 (2000-10-17) abstract; figure 5	12-15		
----- -/--				
<input checked="" type="checkbox"/> Further documents are listed in the continuation of box C.				
<input checked="" type="checkbox"/> Patent family members are listed in annex.				
* Special categories of cited documents :				
<table style="width: 100%; border: none;"> <tr> <td style="width: 50%; border: none; vertical-align: top;"> *A* document defining the general state of the art which is not considered to be of particular relevance *E* earlier document but published on or after the international filing date *L* document which may throw doubts on priority claim(s) or which is cited to establish the publication date of another citation or other special reason (as specified) *O* document referring to an oral disclosure, use, exhibition or other means *P* document published prior to the international filing date but later than the priority date claimed </td> <td style="width: 50%; border: none; vertical-align: top;"> *T* later document published after the international filing date or priority date and not in conflict with the application but cited to understand the principle or theory underlying the invention *X* document of particular relevance; the claimed invention cannot be considered novel or cannot be considered to involve an inventive step when the document is taken alone *Y* document of particular relevance; the claimed invention cannot be considered to involve an inventive step when the document is combined with one or more other such documents, such combination being obvious to a person skilled in the art. *&* document member of the same patent family </td> </tr> </table>			*A* document defining the general state of the art which is not considered to be of particular relevance *E* earlier document but published on or after the international filing date *L* document which may throw doubts on priority claim(s) or which is cited to establish the publication date of another citation or other special reason (as specified) *O* document referring to an oral disclosure, use, exhibition or other means *P* document published prior to the international filing date but later than the priority date claimed	*T* later document published after the international filing date or priority date and not in conflict with the application but cited to understand the principle or theory underlying the invention *X* document of particular relevance; the claimed invention cannot be considered novel or cannot be considered to involve an inventive step when the document is taken alone *Y* document of particular relevance; the claimed invention cannot be considered to involve an inventive step when the document is combined with one or more other such documents, such combination being obvious to a person skilled in the art. *&* document member of the same patent family
A document defining the general state of the art which is not considered to be of particular relevance *E* earlier document but published on or after the international filing date *L* document which may throw doubts on priority claim(s) or which is cited to establish the publication date of another citation or other special reason (as specified) *O* document referring to an oral disclosure, use, exhibition or other means *P* document published prior to the international filing date but later than the priority date claimed	*T* later document published after the international filing date or priority date and not in conflict with the application but cited to understand the principle or theory underlying the invention *X* document of particular relevance; the claimed invention cannot be considered novel or cannot be considered to involve an inventive step when the document is taken alone *Y* document of particular relevance; the claimed invention cannot be considered to involve an inventive step when the document is combined with one or more other such documents, such combination being obvious to a person skilled in the art. *&* document member of the same patent family			
Date of the actual completion of the international search <p style="text-align: center; font-weight: bold;">20 December 2005</p>		Date of mailing of the international search report <p style="text-align: center; font-weight: bold;">28/12/2005</p>		
Name and mailing address of the ISA European Patent Office, P.B. 5818 Patentlaan 2 NL - 2280 HV Rijswijk Tel. (+31-70) 340-2040, Tx. 31 651 epo nl, Fax: (+31-70) 340-3016		Authorized officer <p style="text-align: center; font-weight: bold;">Kronberger, R</p>		

INTERNATIONAL SEARCH REPORT

International Application No
PCT/IB2005/053249

C.(Continuation) DOCUMENTS CONSIDERED TO BE RELEVANT		
Category °	Citation of document, with indication, where appropriate, of the relevant passages	Relevant to claim No.
A	<p>US 6 245 017 B1 (HASHIMOTO SHINICHI ET AL) 12 June 2001 (2001-06-12) claim 8 column 5, lines 46-61; figures 2,6 column 7, line 56 - column 8, line 17; figures 11a,11b column 10, line 35 - column 11, line 21 column 11, line 50 - column 12, line 35; figures 18a-19b column 13, line 51 - column 14, line 31; figures 20a-20e</p> <p>-----</p>	1,10
A	<p>WO 03/045222 A (VIATRONIX INCORPORATED; BITTER, INGMAR; LI, WEI; MEISSNER, MICHAEL; DA) 5 June 2003 (2003-06-05) page 5, lines 2-26 page 6, lines 9-28 page 12, lines 6-23; figures 5a-5b page 17, lines 10-28 page 19, lines 16-24</p> <p>-----</p>	1-11
A	<p>US 2003/156746 A1 (BISSELL ANDREW JOHN ET AL) 21 August 2003 (2003-08-21) paragraphs '0001! - '0003!, '0054!, '0059! - '0061!, '0072!, '0077!, '0097!; figure 11a</p> <p>-----</p>	12-15
A	<p>EP 1 419 737 A (ALOKA CO. LTD) 19 May 2004 (2004-05-19) abstract paragraph '0015!; figures 1,2</p> <p>-----</p>	1

INTERNATIONAL SEARCH REPORT

International Application No
PCT/IB2005/053249

Patent document cited in search report	Publication date	Patent family member(s)	Publication date
WO 2004029655 A	08-04-2004	AU 2003263414 A1 EP 1546759 A1	19-04-2004 29-06-2005
JP 2000287976 A	17-10-2000	NONE	
US 6245017 B1	12-06-2001	NONE	
WO 03045222 A	05-06-2003	AU 2002359443 A1 CA 2466809 A1 EP 1467653 A2	10-06-2003 05-06-2003 20-10-2004
US 2003156746 A1	21-08-2003	AT 250255 T AU 4441601 A DE 60100806 D1 DE 60100806 T2 EP 1272978 A1 GB 2361396 A WO 0178013 A1 JP 2003530176 T	15-10-2003 23-10-2001 23-10-2003 15-07-2004 08-01-2003 17-10-2001 18-10-2001 14-10-2003
EP 1419737 A	19-05-2004	JP 2004159997 A US 2004097808 A1	10-06-2004 20-05-2004

专利名称(译)	具有图像反转和反演的三维诊断超声成像系统		
公开(公告)号	EP1799117A1	公开(公告)日	2007-06-27
申请号	EP2005787214	申请日	2005-10-03
[标]申请(专利权)人(译)	皇家飞利浦电子股份有限公司		
申请(专利权)人(译)	皇家飞利浦电子N.V.		
当前申请(专利权)人(译)	皇家飞利浦N.V.		
[标]发明人	FRISA JANICE THIELE KARL PRATER DAVID LIU LARRY LINGNAN		
发明人	FRISA, JANICE THIELE, KARL PRATER, DAVID LIU, LARRY LINGNAN		
IPC分类号	A61B8/14 G01S15/89 G01S7/52		
CPC分类号	A61B8/483 A61B8/14 A61B8/4405 G01S7/52068 G01S7/52073 G01S7/52074 G01S7/52095 G01S15/8925 G01S15/8993 G01S15/8995		
优先权	60/617492 2004-10-08 US		
其他公开文献	EP1799117B1		
外部链接	Espacenet		

摘要(译)

三维超声成像系统从体积区域获取3D图像数据，并处理该图像数据以在给定方向上产生该体积区域的实况3D图像。如果需要，用户控制可以由用户切换以以不同的方向呈现图像。可以反转3D图像中的解剖结构和图像格式，并且可以通过解剖结构的相应的前后反转来反转3D图像的左右外观。