



(19) **United States**

(12) **Patent Application Publication**  
**LIN et al.**

(10) **Pub. No.: US 2018/0263502 A1**  
(43) **Pub. Date: Sep. 20, 2018**

(54) **METHOD AND APPARATUS FOR  
NON-CONTACT FAST VITAL SIGN  
ACQUISITION BASED ON RADAR SIGNAL**

*A61B 5/00* (2006.01)  
*G01S 13/88* (2006.01)  
*G01S 13/58* (2006.01)

(71) Applicant: **THE UNIVERSITY OF FLORIDA  
RESEARCH FOUNDATION, INC.**,  
Gainesville, FL (US)

(52) **U.S. Cl.**  
CPC ..... *A61B 5/0205* (2013.01); *A61B 5/05*  
(2013.01); *A61B 5/7239* (2013.01); *A61B*  
*5/1102* (2013.01); *G01S 13/88* (2013.01);  
*G01S 13/583* (2013.01); *A61B 5/7214*  
(2013.01)

(72) Inventors: **JENSHAN LIN**, GAINESVILLE, FL  
(US); **CHANGYU WEI**,  
GAINESVILLE, FL (US)

(57) **ABSTRACT**

(21) Appl. No.: **15/517,214**

Various examples are provided for non-contact vital sign acquisition. Information can be provided regarding vibrations of a target using a radar signal such as, e.g., non-contact vital sign measurement. Examples include estimation of heart rate, change in heart rate, respiration rate, and/or change in respiration rate, for a human or other animal. Implementations can produce one or both rates of vibration and/or change in one or both rates of vibration for a target other than an animal or human experiencing two vibrations at the same time, such as a motor, a vehicle incorporating a motor, or another physical object. Some implementations can estimate the respiration movement in the radar baseband output signal. The estimated respiration signal can then be subtracted from radar signals in the time domain and, optionally, can be further enhanced using digital signal processing techniques, to produce an estimate of the heartbeat pulses.

(22) PCT Filed: **Oct. 8, 2015**

(86) PCT No.: **PCT/US15/54669**

§ 371 (c)(1),

(2) Date: **Apr. 6, 2017**

**Related U.S. Application Data**

(60) Provisional application No. 62/061,320, filed on Oct. 8, 2014.

**Publication Classification**

(51) **Int. Cl.**

*A61B 5/0205* (2006.01)  
*A61B 5/05* (2006.01)

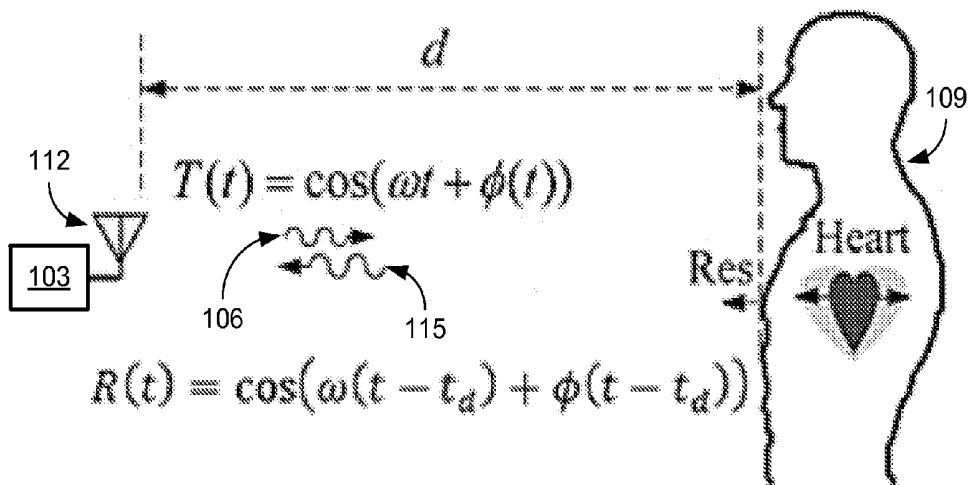

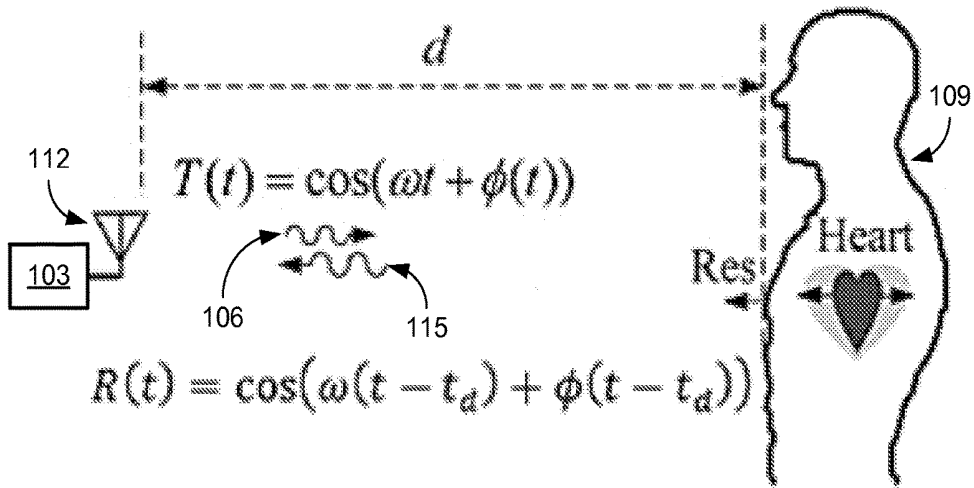

FIG. 1

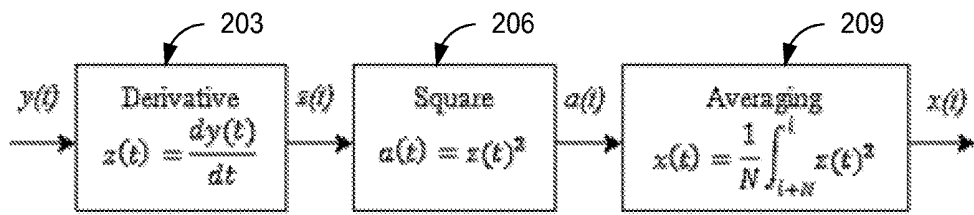

FIG. 2

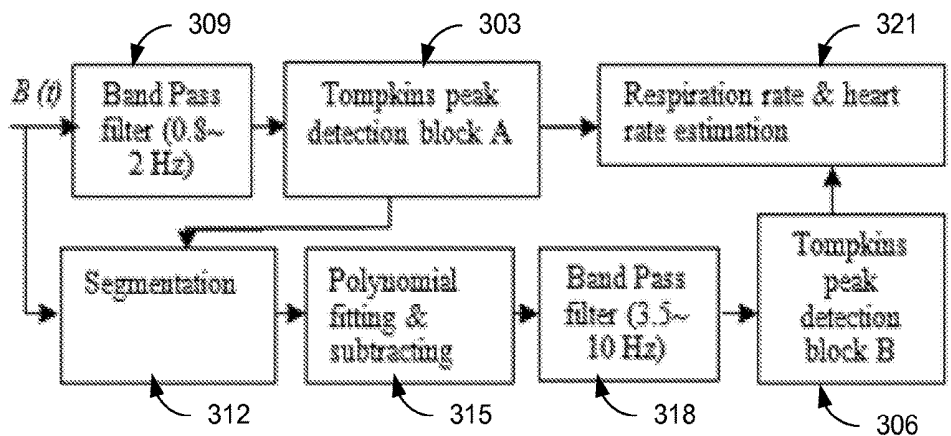
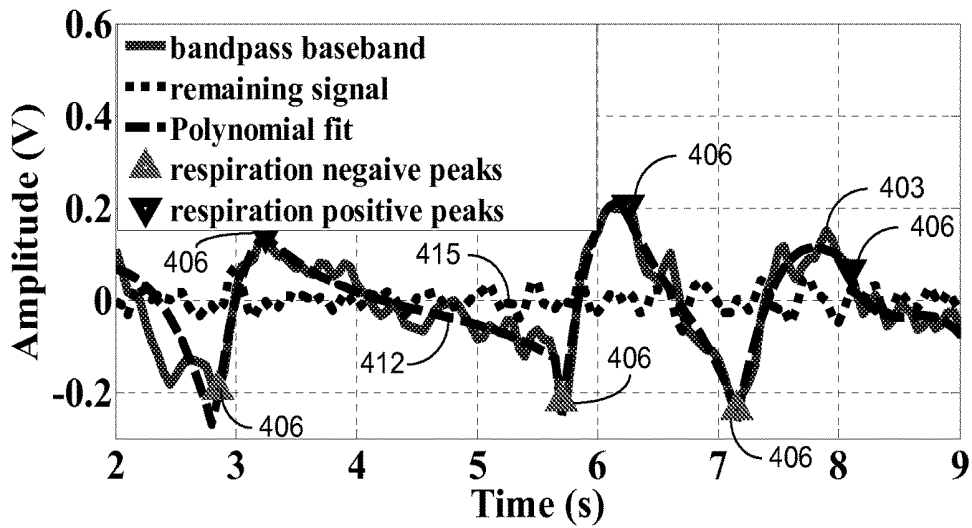
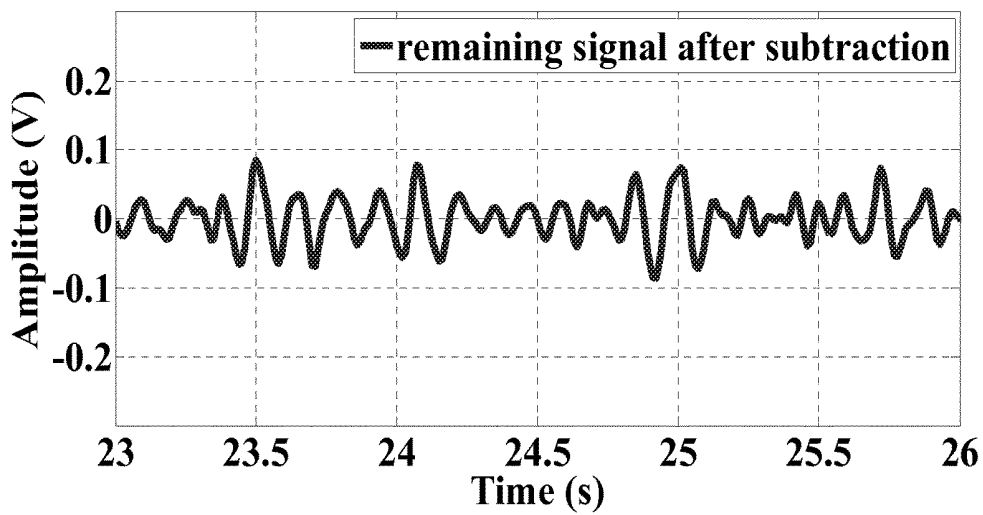

FIG. 3



**FIG. 4**



**FIG. 5A**

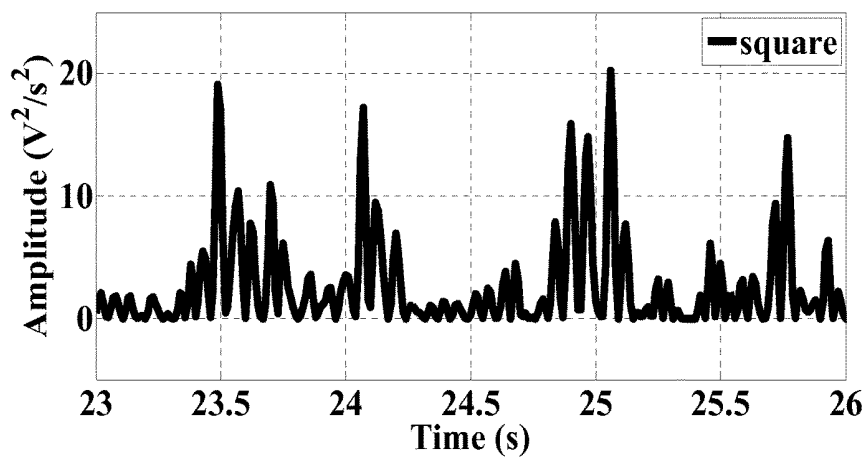

**FIG. 5B**

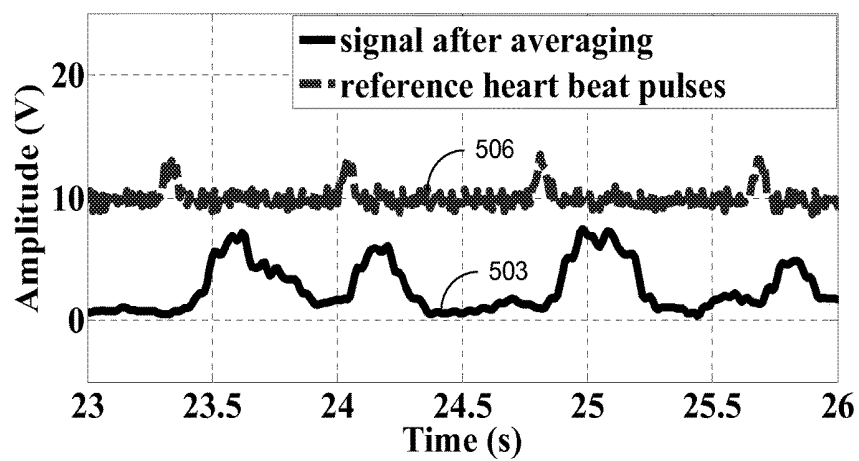

**FIG. 5C**

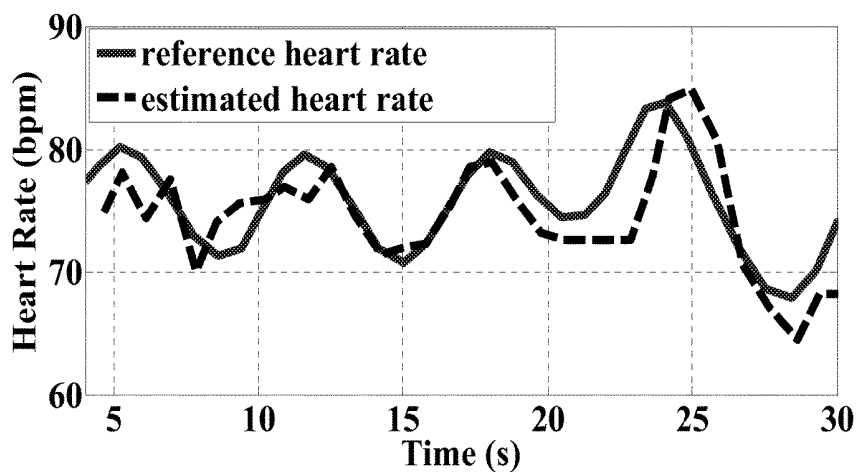

**FIG. 6**

TABLE I  
ERROR IN HEART RATE MEASUREMENTS

Heart rate Root Mean Square error (bpm)	Subject 1 (male)	Subject 2 (female)	Subject 3 (male)
data set 1	3.27	3.93	3.84
data set 2	3.73	3.76	4.38

**FIG. 7**

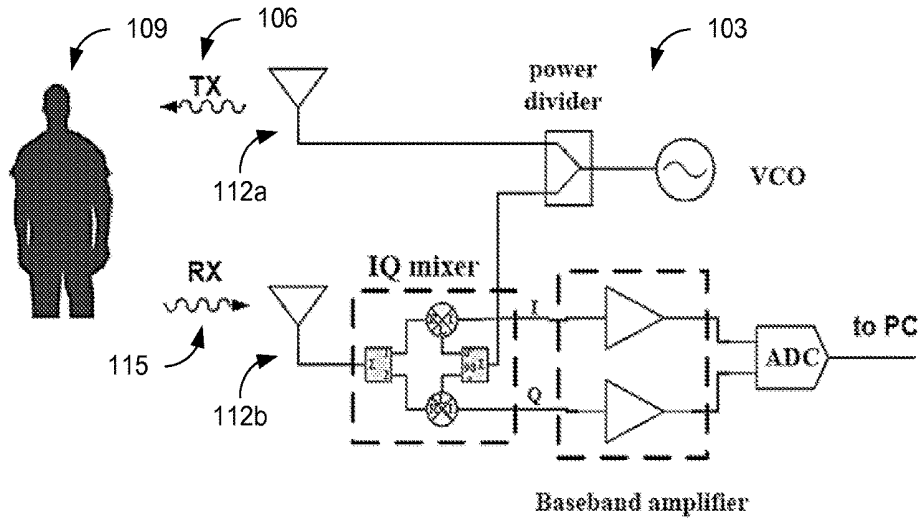

FIG. 8

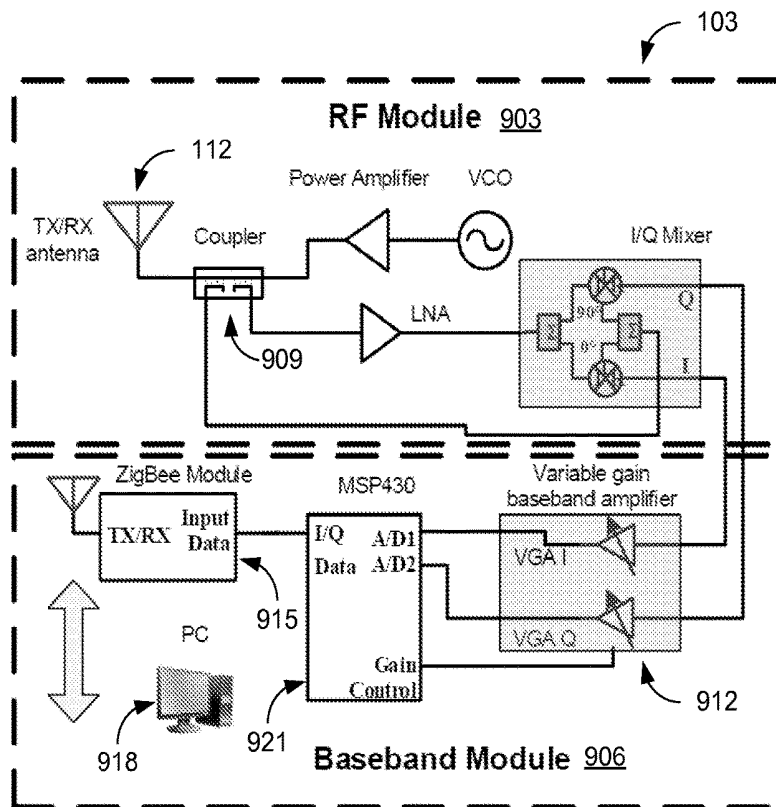
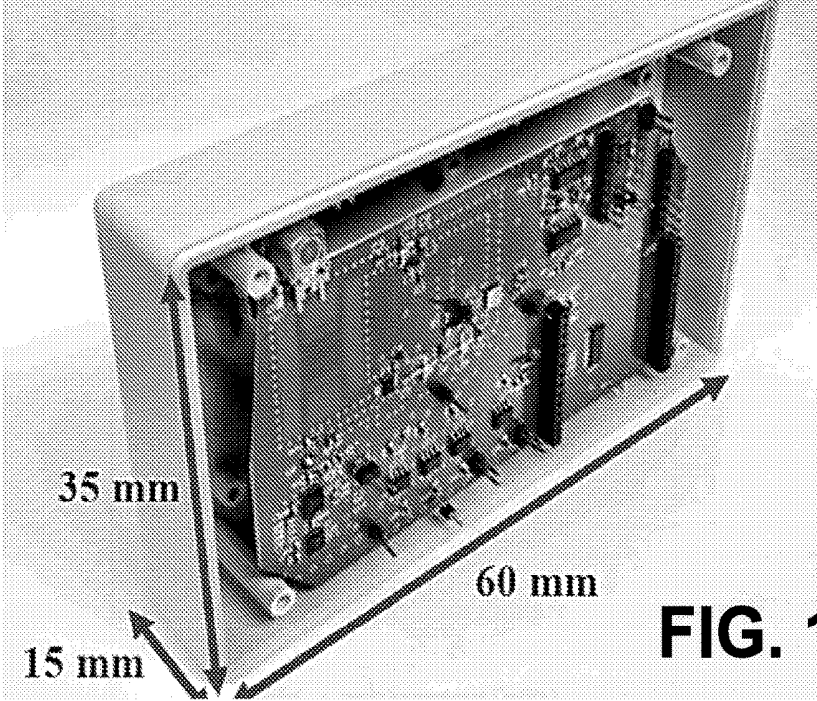
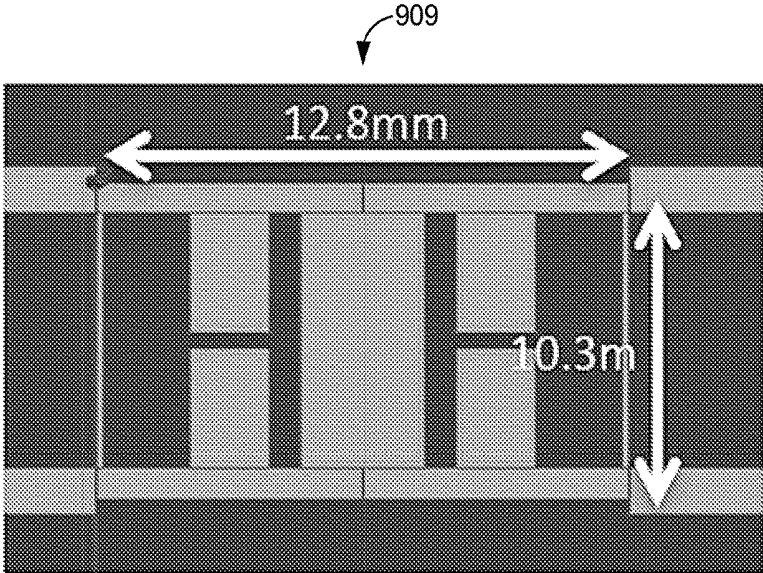

FIG. 9



**FIG. 10**



**FIG. 11**

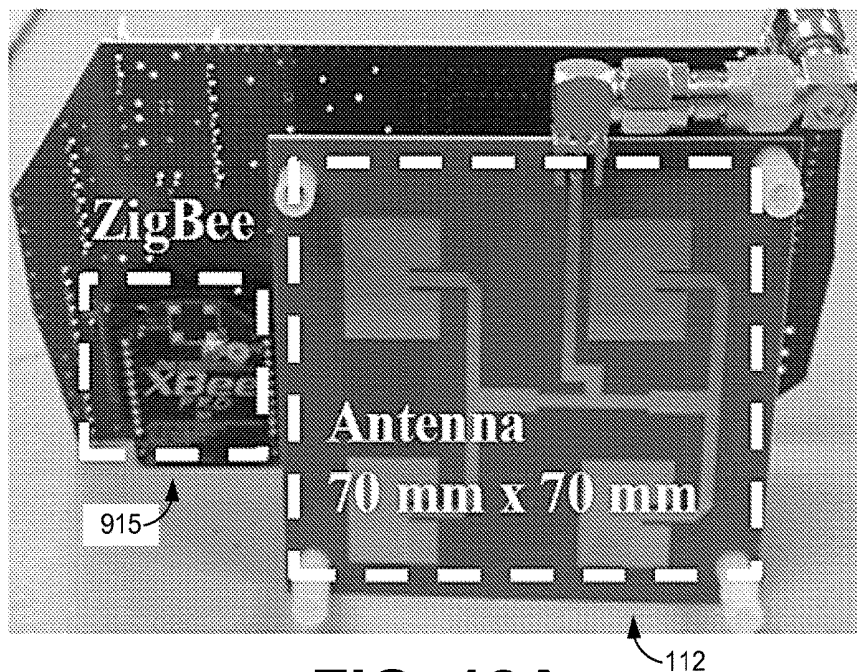

**FIG. 12A**

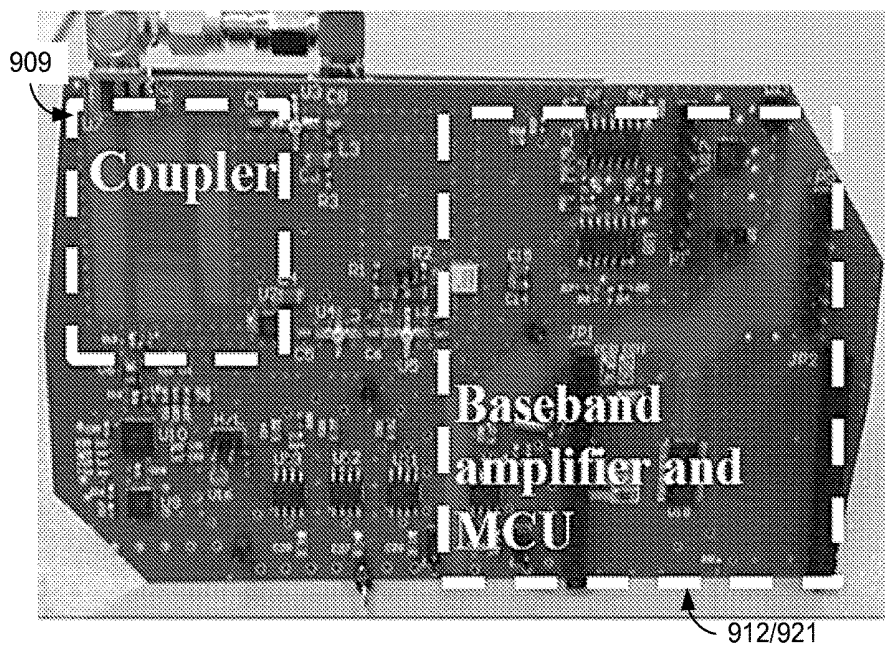

**FIG. 12B**

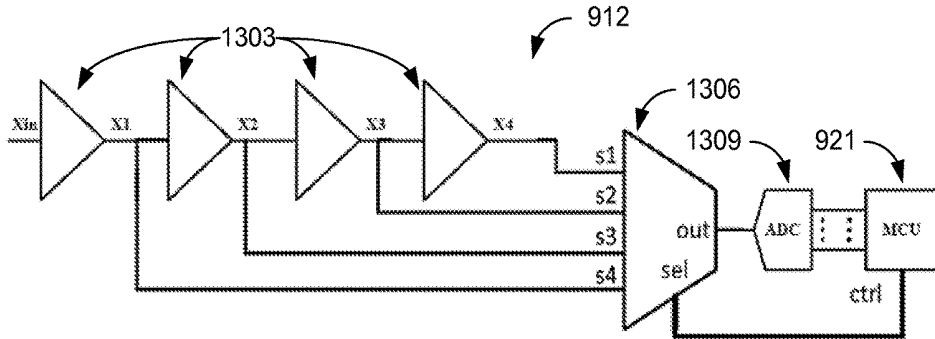

**FIG. 13**

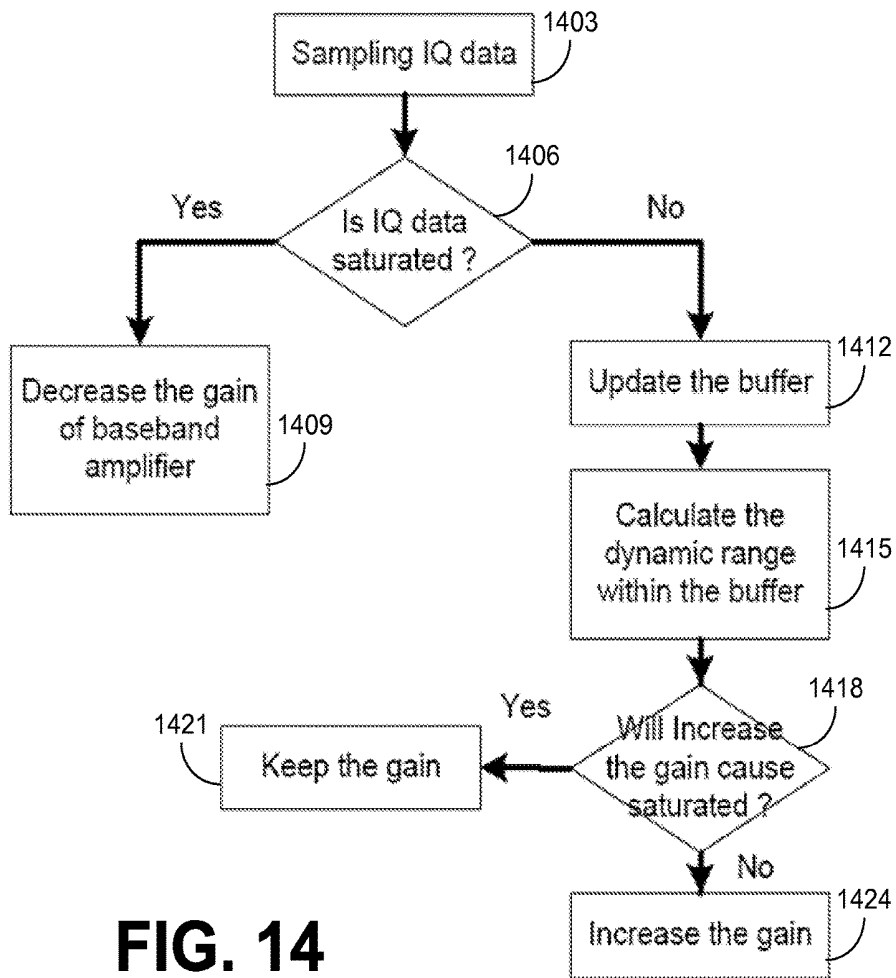

**FIG. 14**

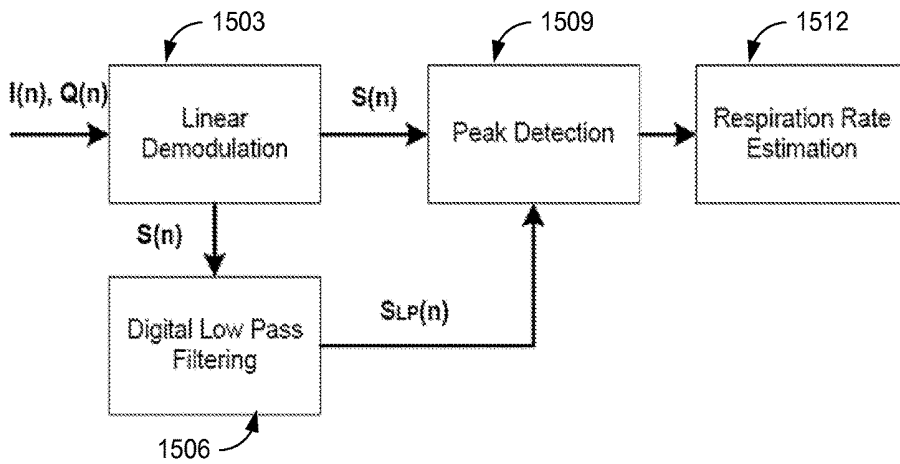

FIG. 15

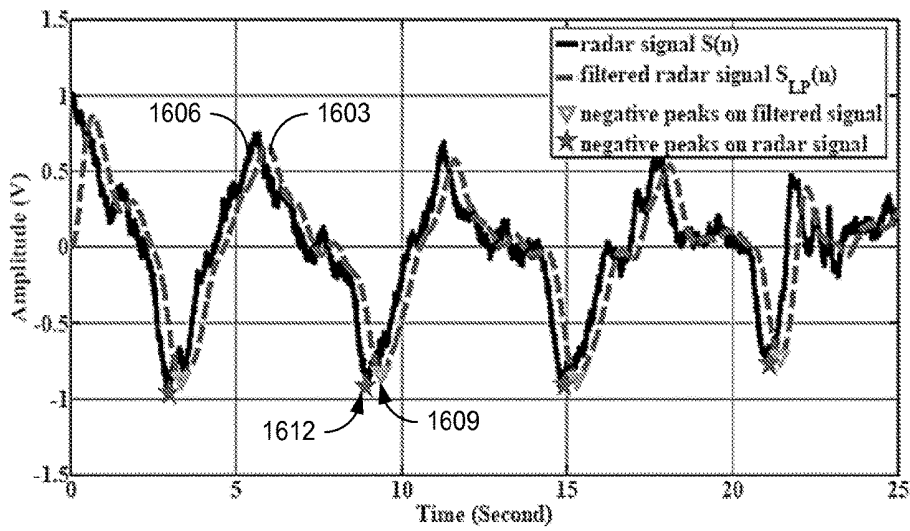

FIG. 16A

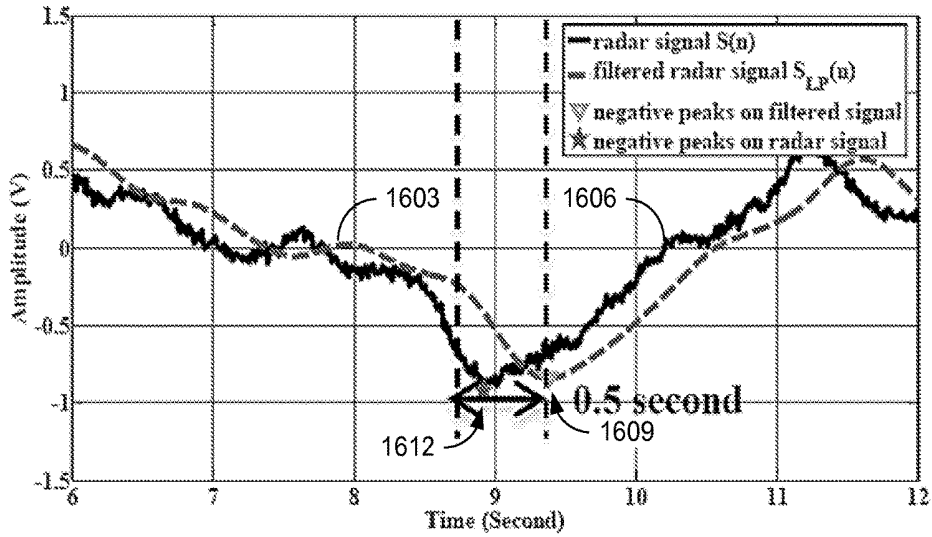

FIG. 16B

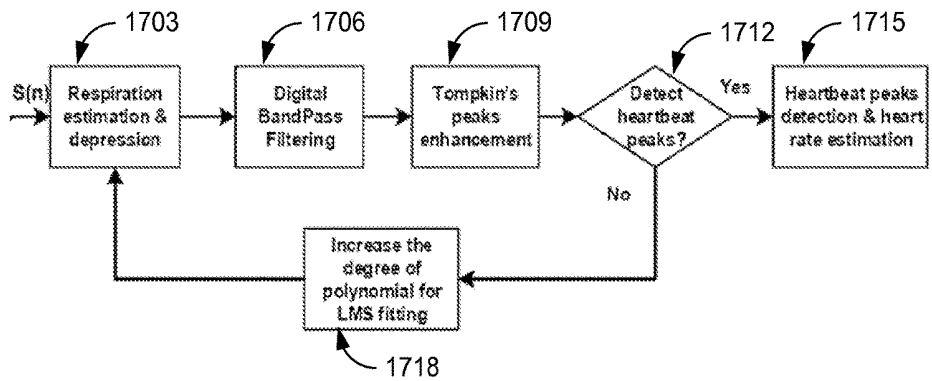

FIG. 17

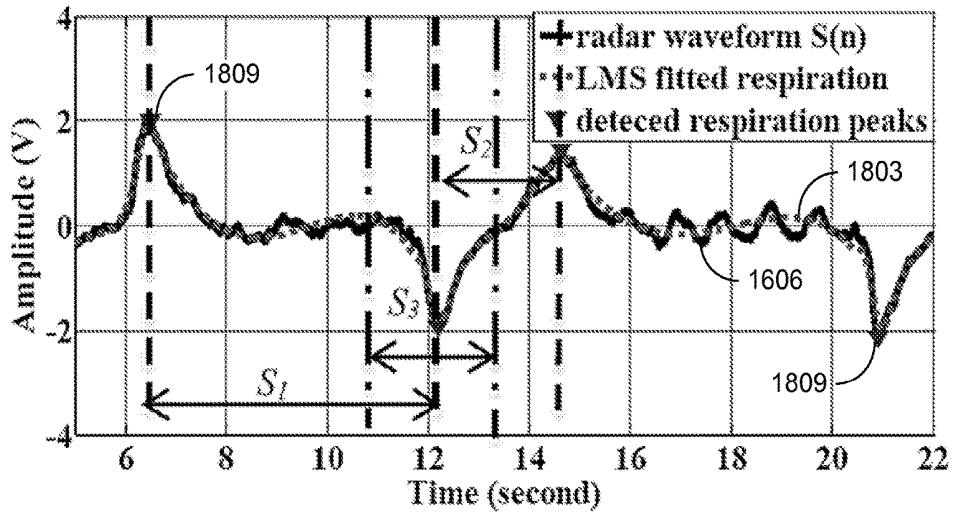

FIG. 18A

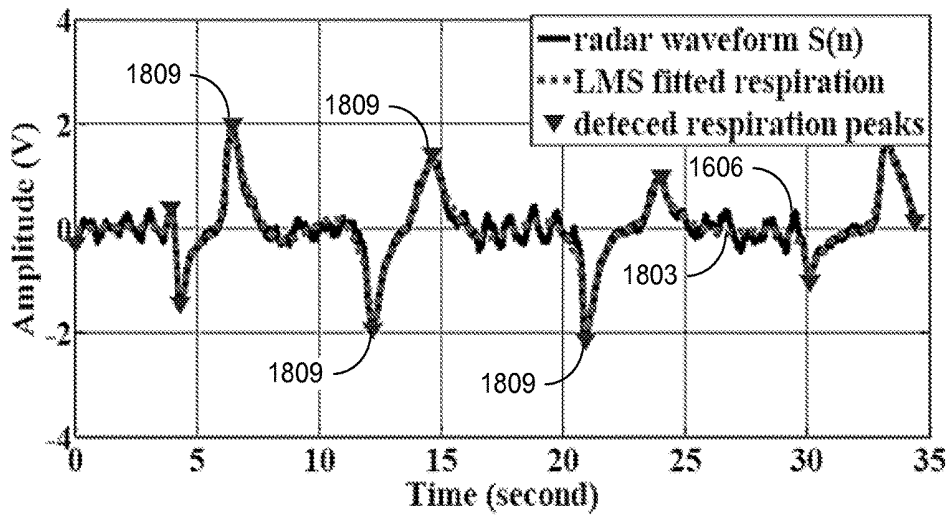
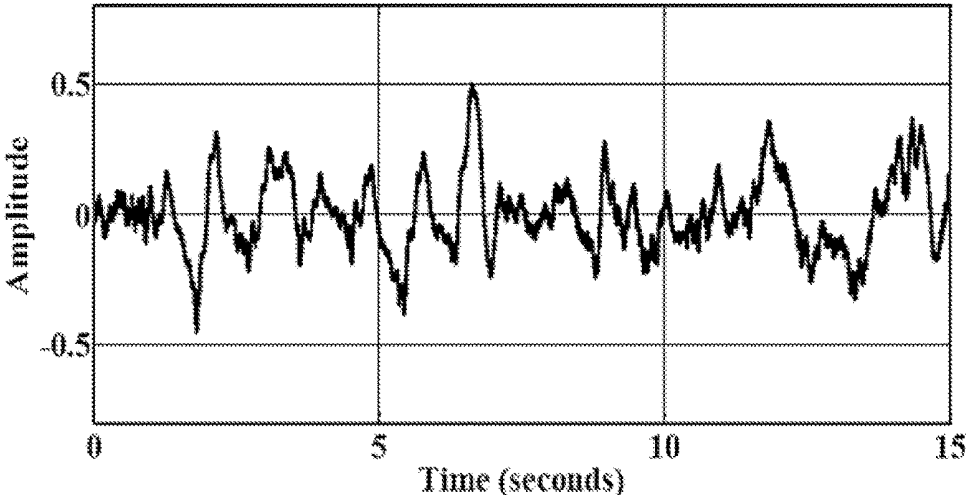
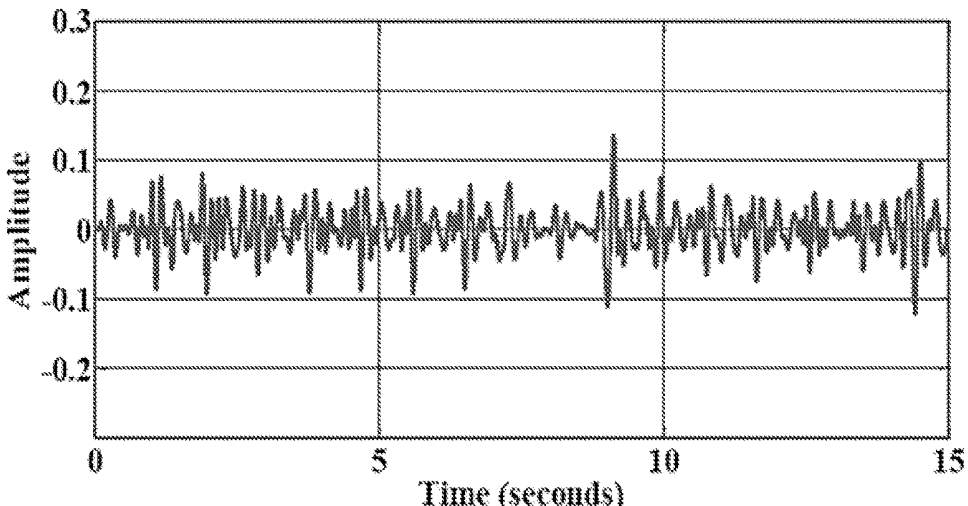

FIG. 18B



**FIG. 19A**



**FIG. 19B**

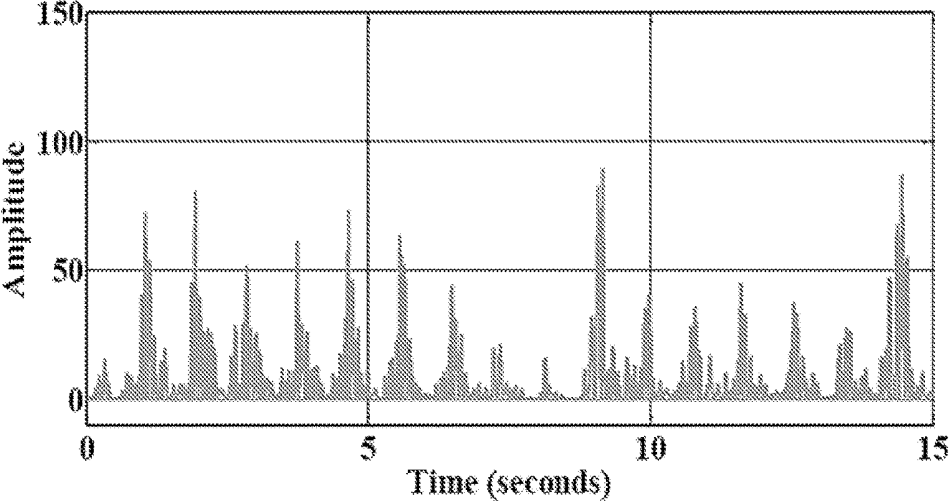

**FIG. 19C**

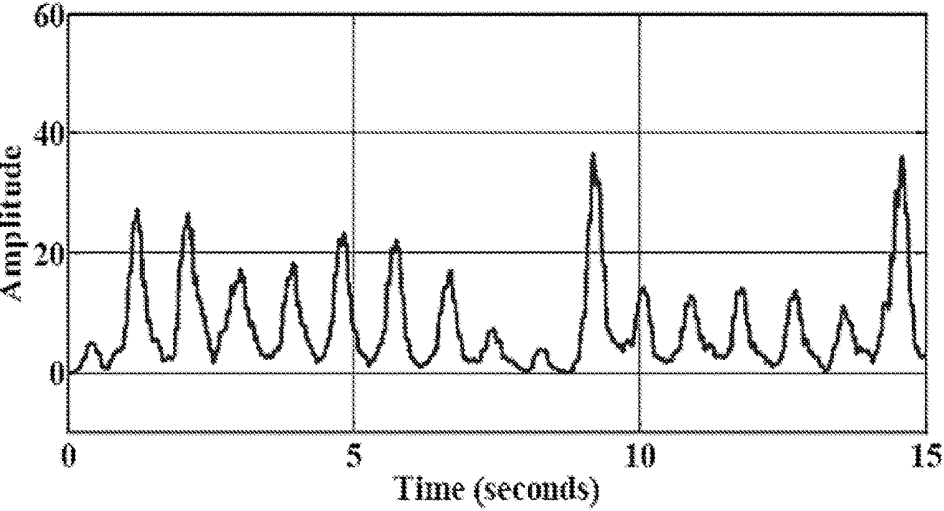

**FIG. 19D**

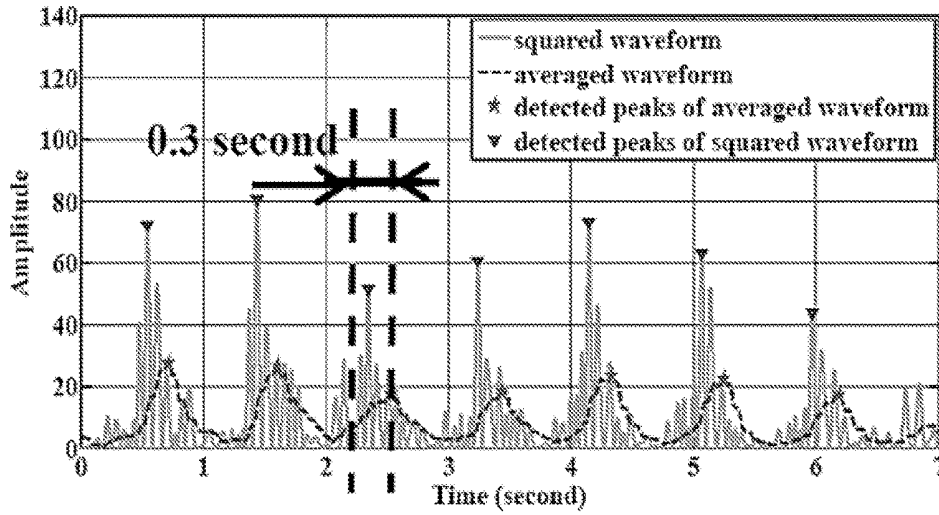

**FIG. 20**

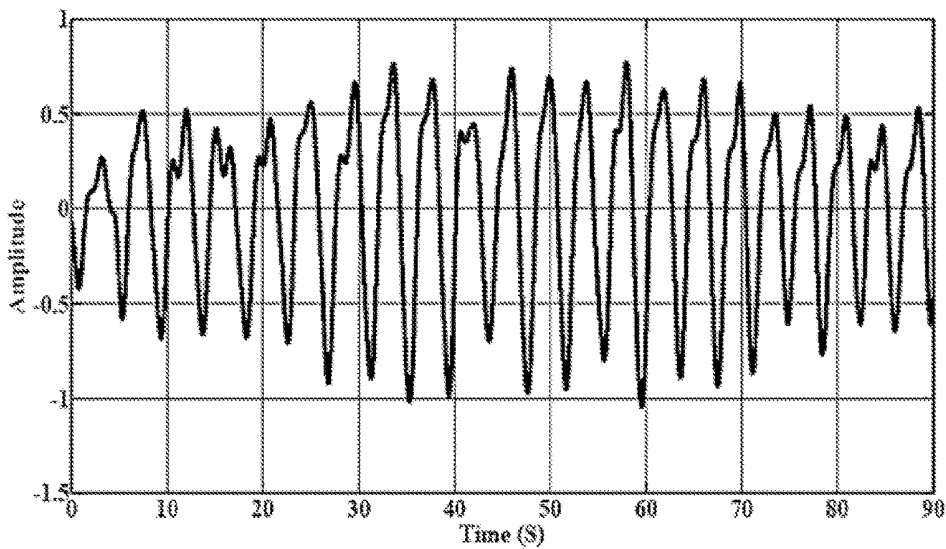

**FIG. 21A**

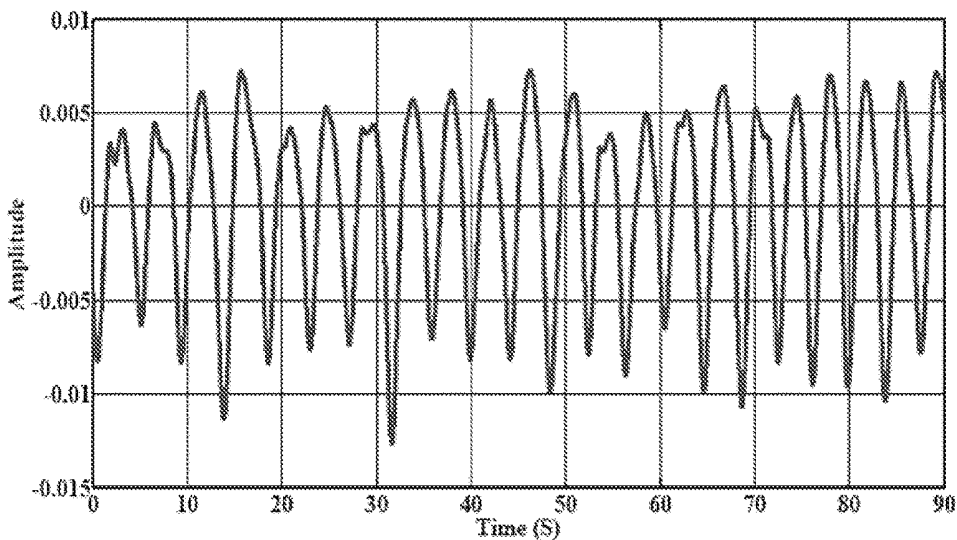

**FIG. 21B**

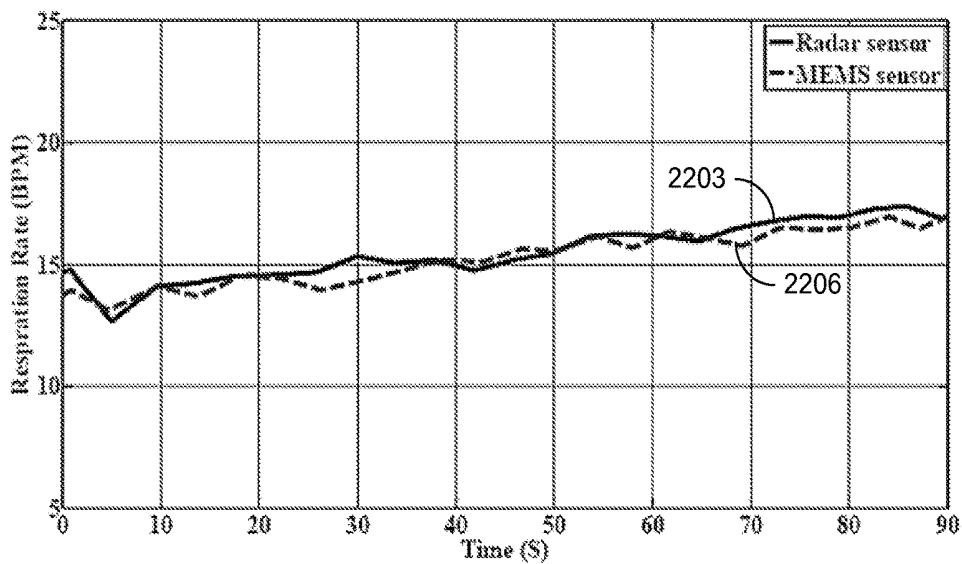

**FIG. 22**

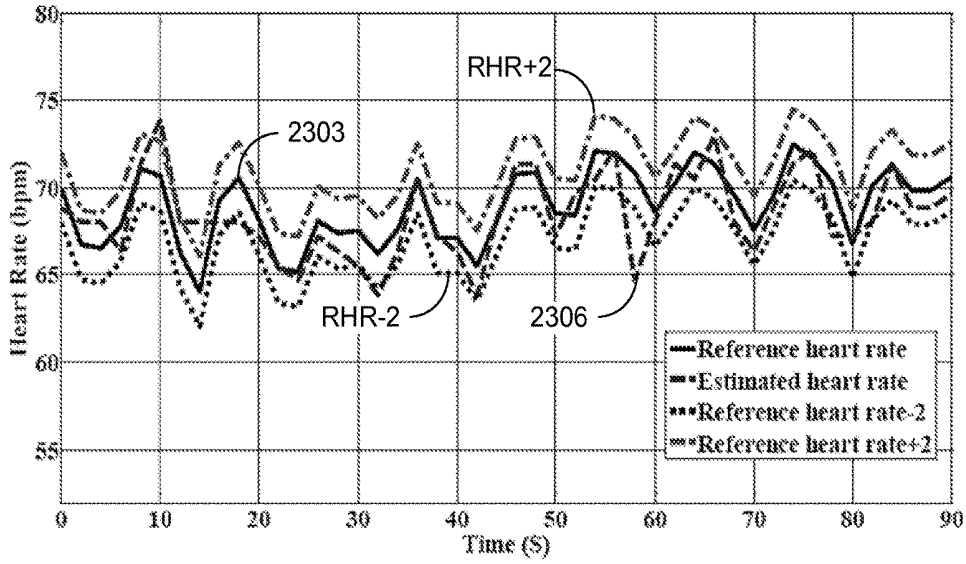

**FIG. 23**

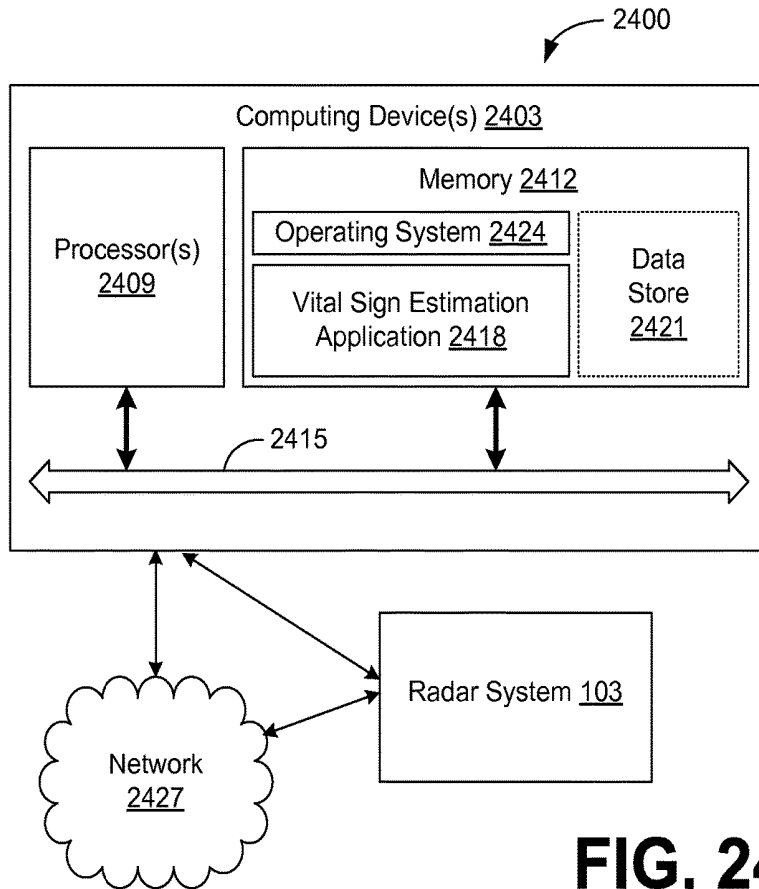

**FIG. 24**

**METHOD AND APPARATUS FOR  
NON-CONTACT FAST VITAL SIGN  
ACQUISITION BASED ON RADAR SIGNAL**

CROSS REFERENCE TO RELATED  
APPLICATIONS

**[0001]** This application claims priority to, and the benefit of, co-pending U.S. provisional application entitled “METHOD AND APPARATUS FOR NON-CONTACT FAST VITAL SIGN ACQUISITION BASED ON RADAR SIGNAL” having Ser. No. 62/061,320, filed Oct. 8, 2014, which is hereby incorporated by reference in its entirety.

BACKGROUND

**[0002]** Accurate determination of patient vital signs is important in many situations. Research results show that non-contact vital sign sensing has significant advantages in applications such as detecting human subjects in disaster in-field rescue, through-wall human tracking, apexcardiography (ACG) measurement for hemodynamics monitoring and evaluating the status of patients who are exposed to toxic chemicals or suffer serious burn wounds.

SUMMARY

**[0003]** Embodiments of the present disclosure are related to non-contact vital sign acquisition such as fast acquisition of vital signs based on radar signals. Embodiments can be used for providing information regarding vibrations of a target using a radar signal. Embodiments can be used for non-contact vital sign measurement using a radar signal. Various embodiments relate to a method and apparatus for heart rate estimation. Embodiments can also provide respiration rate. Embodiments can be used to provide heart rate, change in heart rate, respiration rate, and/or change in respiration rate for a human, an animal, a dog, a cat, a horse, or other animal. Embodiments can also be used to produce one or both rates of vibration and/or change in one or both rates of vibration for a target other than an animal or human that is experiencing two vibrations at the same time, such as a motor, a vehicle incorporating a motor, or another physical object.

**[0004]** Embodiments can estimate the respiration movement in the radar baseband output signal. The estimated respiration signal can then be subtracted from radar signals in time domain and, optionally, further enhanced using digital signal processing techniques, to produce an estimate of the heartbeat pulses. The use of time-domain subtraction can result in a vital sign extraction and estimation method having certain advantages compared with traditional vital sign estimation methods based on spectral analysis.

**[0005]** Embodiments can utilize a peak detection algorithm. By detecting respiration peaks and performing a polynomial fit according to the locations of the respiration peaks, the respiration signal (including the harmonic components of the respiration signal) can be filtered out from the radar baseband signal, and can achieve real time extraction of the heartbeat pulses. The heart rate and respiration rate can be calculated by estimating the time intervals between extracted peaks. Embodiments can realize a fast estimation of vital sign information.

**[0006]** Various embodiments can have one or more of the following advantages. Extraction of time-domain waveforms for respiration and heartbeats can reduce, or eliminate,

a spectrum distortion problem (e.g., higher order harmonics of respiration overwhelming heartbeat signal) common in frequency-domain analysis. A real-time respiration and heartbeat waveform can be produced for fast vital sign estimation, such as within 20 seconds, 15 seconds, 10 seconds, 9 seconds, 8 seconds, 7 seconds, 6 seconds, and/or 5 seconds. Real time changes in the heart rate and/or real time changes in the respiration rate can be produced, which can be useful for some medical analyses, such as the Heart Rate Variability (HRV) analysis.

**[0007]** Some embodiments can suppress signals due to respiration, such as fundamental respiration signal and/or higher order harmonics of the fundamental respiration signal, and can extract heartbeat pulses using a real-time time-domain analysis, without harmonic distortion, to provide fast and accurate vital sign estimation. Embodiments can produce a time varying output of the respiration rate and/or time-varying output of the heart rate. Embodiments can output a signal reading of the respiration rate and/or heart rate, or produce an updated reading of the respiration rate and/or heart rate every X seconds, such as every 60 seconds, every 30 seconds, every 15 seconds, every 10 seconds, every 5 seconds, and/or some other period of time. Compared to previous spectral-domain methods that typically have a delay of more than 20 seconds, embodiments of the subject method and apparatus have less delay, and can produce a heart rate reading in less than 20 seconds, e.g., within 6 seconds, within 5 seconds, within 4 seconds, within 3 seconds, and/or within 2 seconds.

**[0008]** Other systems, methods, features, and advantages of the present disclosure will be or become apparent to one with skill in the art upon examination of the following drawings and detailed description. It is intended that all such additional systems, methods, features, and advantages be included within this description, be within the scope of the present disclosure, and be protected by the accompanying claims.

BRIEF DESCRIPTION OF THE DRAWINGS

**[0009]** Many aspects of the present disclosure can be better understood with reference to the following drawings. The components in the drawings are not necessarily to scale, emphasis instead being placed upon clearly illustrating the principles of the present disclosure. Moreover, in the drawings, like reference numerals designate corresponding parts throughout the several views.

**[0010]** FIG. 1 illustrates an example of the operation of vital sign detection using Doppler vital sign radar, in accordance with various embodiments of the present disclosure.

**[0011]** FIG. 2 is a flow chart illustrating an example of Tompkins peak detection and enhancement, in accordance with various embodiments of the present disclosure.

**[0012]** FIG. 3 is a block diagram illustrating an example of fast vital sign detection, in accordance with various embodiments of the present disclosure.

**[0013]** FIG. 4 illustrates examples of bandpass signal amplitude versus time, polynomial fit of the respiration signal, remaining signal, and respiration negative and positive peaks, in accordance with various embodiments of the present disclosure.

**[0014]** FIGS. 5A through 5C illustrates examples of signals after respiration movement subtraction and bandpass

filtering, after taking the derivative and squaring, and after averaging, in accordance with various embodiments of the present disclosure.

[0015] FIG. 6 illustrates an example of the estimated heart rate and the reference heart rate, in accordance with various embodiments of the present disclosure.

[0016] FIG. 7 is a table illustrating examples of error in heart rate measurements, in accordance with various embodiments of the present disclosure.

[0017] FIG. 8 is a schematic diagram illustrating an example of a radar system for non-contact vital sign detection, in accordance with various embodiments of the present disclosure.

[0018] FIG. 9 is a block diagram illustrating an example of a portable radar system for vital sign detection, in accordance with various embodiments of the present disclosure.

[0019] FIG. 10 is an image of the portable radar system of FIG. 9, in accordance with various embodiments of the present disclosure.

[0020] FIG. 11 is an image of a T-model branch-line coupler of the portable radar system of FIG. 9, in accordance with various embodiments of the present disclosure.

[0021] FIGS. 12A and 12B are images of the portable radar system of FIG. 9, in accordance with various embodiments of the present disclosure.

[0022] FIG. 13 is a schematic diagram illustrating an example of a variable gain amplifier (VGA) of the portable radar system of FIG. 9, in accordance with various embodiments of the present disclosure.

[0023] FIG. 14 is a flow chart illustrating an example of the adjustment of the VGA of FIG. 13, in accordance with various embodiments of the present disclosure.

[0024] FIG. 15 is a flow chart illustrating an example of estimating the respiration rate of a subject, in accordance with various embodiments of the present disclosure.

[0025] FIGS. 16A and 16B illustrate the respiration rate estimation, in accordance with various embodiments of the present disclosure.

[0026] FIG. 17 is a flow chart illustrating flow chart illustrating an example of estimating the heart rate of the subject, in accordance with various embodiments of the present disclosure.

[0027] FIGS. 18A and 18B illustrate the heart rate estimation, in accordance with various embodiments of the present disclosure.

[0028] FIGS. 19A through 19D illustrate examples of waveforms of Tompkins peak detection and enhancement, in accordance with various embodiments of the present disclosure.

[0029] FIG. 20 illustrates an example of peaks detection using a squared waveform and averaged waveform, in accordance with various embodiments of the present disclosure.

[0030] FIGS. 21A and 21B illustrate an example of respiration waveforms from the portable radar system of FIG. 9 and a MEMS sensor on the subject, in accordance with various embodiments of the present disclosure.

[0031] FIG. 22 illustrates an example of a comparison of estimated and measured respiration rates, in accordance with various embodiments of the present disclosure.

[0032] FIG. 23 illustrates an example of a comparison between reference and estimated heart rates, in accordance with various embodiments of the present disclosure.

[0033] FIG. 24 is an example of a system that may be utilized in vital sign estimation, in accordance with various embodiments of the present disclosure.

#### DETAILED DESCRIPTION

[0034] Disclosed herein are various embodiments of methods, systems and apparatus related to non-contact vital sign acquisition. Fast acquisition of vital signs is possible based on radar signals. Reference will now be made in detail to the description of the embodiments as illustrated in the drawings, wherein like reference numbers indicate like parts throughout the several views.

[0035] Embodiments can be used for providing information regarding vibrations of a target using a radar signal. Embodiments can be used for non-contact vital sign measurement using a radar signal. Various embodiments relate to a method and apparatus for heart rate or other vital sign estimation. Embodiments can also provide respiration rate. Embodiments can be used to provide heart rate, change in heart rate, respiration rate, and/or change in respiration rate for a human, an animal, a dog, a cat, a horse, or other animal. Embodiments can also be used to produce one or both rates of vibration and/or change in one or both rates of vibration for a target other than an animal or human that is experiencing two vibrations at the same time, such as a motor, a vehicle incorporating a motor, or another physical object.

[0036] Embodiments can estimate the respiration movement in the radar baseband output signal. The estimated respiration signal can then be subtracted from radar signals in time domain and, optionally, further enhanced using digital signal processing techniques, to produce an estimate of the heartbeat pulses. The use of time-domain subtraction can result in a vital sign extraction and estimation method having certain advantages compared with traditional vital sign estimation methods based on spectral analysis.

[0037] One challenge in vital sign sensing is the estimation of a subject's heart rate from the reflected radar signals. While measuring from the front side of a person, the reflected radar signal can be dominated by respiration movements. The higher order harmonics of the respiration can overwhelm the heartbeat components, causing errors or inaccuracy in heart rate estimation. Reliable heart rate estimation from a reflected radar signal distorted by respiration movements may be achieved through various methods.

[0038] The heart rate may be measured from the back side of human subjects where the respiration movement is not significant. This method can be applied to subjects staying in bed with the right posture for measurements. Differential radiation, front end implemented with two antennas, can be used to estimate respiration movements. By canceling the respiration signal, the quality of heartbeat signal can be improved. However, respiration can also introduce differential signals in the dual antenna design and corrupt the heartbeat waveforms. Advanced signal processing methods, such as RELAX, may be used to improve the heart rate estimation in a limited measurement time window. However, such advanced signal processing methods utilize significant computational power and relatively long measurement periods for data analysis. For example, data having a 13.5 s length can be used for heart rate estimation. Such long measurement periods can cause undesirable delay in real time applications.

**[0039]** A heart rate estimation method is discussed in this disclosure, which can be based on peak detection. By detecting respiration peaks and conducting polynomial fit according to the peaks' locations, the respiration signal (which can include its harmonic components) can be filtered out from the radar baseband signal and achieve real time heartbeat pulses extraction. Since the heart rate and respiration rate can be calculated via estimating the time intervals between extracted peaks, this algorithm provide a fast estimation of vital sign information.

**[0040]** FIG. 1 illustrates an example of the principle of operation of a Doppler radar vital sign detection method and system in accordance with various embodiments of the present disclosure. As shown in the example of FIG. 1, a Doppler radar system **103** sends a transmitting signal **106**, which can be expressed as:

$$T(t)=\cos(\omega t+\varphi(t)), \quad (1)$$

toward the human subject **109**, where  $\varphi(t)$  is the phase noise of the oscillator in the radar system **103**. The radar signal **106** can have a frequency in the range from 1 GHz to 30 GHz, although other frequencies can be used. As examples, for small animals with smaller vital sign physiological displacements, the frequency range can be higher than 30 GHz, and for large animals with larger vital sign physiological displacements, the frequency range can be lower than 1 GHz.

**[0041]** In the example of FIG. 1, the transmitted signal **106** (e.g., at 5.8 GHz) hits the front chest of the subject **109** and is reflected back to the sensor **112** (e.g., an antenna) of the radar system **103**. The reflected signal **115** received by the sensor **112** can be expressed as:

$$R(t)=\cos(\omega(t-t_d)+\varphi(t-t_d)), \quad (2)$$

where  $t_d$  is the time needed for the transmitted radar signal **106** to travel from the transmitting antenna to the subject and for the reflected signal **115** to travel from the subject **109** back to the receiving antenna **112**.

**[0042]** Assuming the transmitting and receiving antennas **112** are the same distance,  $d$ , from the subject **109**, then:

$$t_d=2d/c, \quad (3)$$

where  $c$  is the light speed in free space and  $d$  is the distance between the radar transmitting antenna **112** and the subject **109**. The distance between the receiving antenna **112** and the subject **109** can also be assumed to be  $d$  if the transmitting and receiving antennas **112** are the same distance from the subject **109**. In some embodiments, a single antenna **112** can be utilized to both transmit and receive and, in other embodiments, separate transmitting and receiving antennas can be used. When separate antennas are used, the distance from the transmitting antenna to the subject may be different than the distance from the receiving antenna to the subject.

**[0043]** If the transmitting antenna and receiving antenna are not the same distance from the subject, then equations (2) and (3) can be adjusted. When the distance,  $d_t$ , from the transmitting antenna to the subject **109** is approximately the same as the distance,  $d_r$ , from the subject **109** to the receiving antenna **112** and the time  $t_d=(d_t+d_r)/c$ , the approximation that  $d_t=d_r=d$  produces satisfactory results.

**[0044]** The distance,  $d$ , can be expanded as:

$$d=d_0+x_h(t)+x_r(t), \quad (4)$$

where  $x_h(t)$ ,  $x_r(t)$  are the movements of the subject's front chest due to heartbeat and respiration, and  $d_0$  is the averaged

distance between the radar **103** and the subject **109**. In short distance measurements (for example, where  $d_0$  is 1 m or less), the phase noise of the oscillator can be approximated as  $\varphi(t-t_d)\approx\varphi(t)$  due to the range correlation effects.

**[0045]** As an example, the received radar signal **115** can then be approximated as  $\varphi(t-t_d)\approx\varphi(t)$  when  $d$  (the distance between transmitting antenna and target) is less than 300 m, and the roundtrip delay,  $t_d$  when the transmitting antenna and receiving antenna are the same distance from the subject is less than  $2\ \mu\text{s}$  (microseconds). This delay is sufficiently short that the random phase fluctuations (or phase noise) of the signal source with rates near the vital sign rates is greatly reduced by self-mixing at the radar receiver (the so-called range correlation effect).

**[0046]** The reflected signal **115** received by the receiver can then be approximated by:

$$R(t)\approx I(t)\cos(\omega t+\varphi(t))+Q(t)\sin(\omega t+\varphi(t)), \quad (5)$$

where  $I(t)$  is the I channel,  $I(t)=\cos(4\pi d/\lambda)$  and  $Q(t)$  is the Q channel,  $Q(t)=\sin(4\pi d/\lambda)$ . A signal representative of the received radar signal **115** can then be produced, and analyzed to obtain information about the vibrations of the target **109**. Examples of a signal representative of the received radar signal **115** include, but are not limited to, the I channel, the Q channel, the better signal of the I channel and the Q channel, or some combination of the I channel and Q channel such as  $aI+bQ$  or  $aI+ibQ$ , where  $a$  and  $b$  are constants. The signal representative of the received radar signal  $R(t)I$  can then be processed to extract information regarding one or more vibrations, e.g., the vibrations of respiration and/or heartbeat.

**[0047]** In a specific embodiment, the signal representative of  $R(t)$  is the baseband signal  $B(t)$ . By combining  $I(t)$  and  $Q(t)$  signals, the baseband signal  $B(t)$ , whose phase contains the vital sign information, can be represented as:

$$B(t)=I(t)+jQ(t)=\exp(j4\pi d_0/\lambda)\exp(j(4\pi x_h(t)+4\pi x_r(t))/\lambda) \quad (6)$$

**[0048]** A subject's vital sign information can be estimated by analyzing the baseband signal  $B(t)$ , which is representative of the received signal **115**.  $B(t)$  can be analyzed within a short time window, such as within 20, 15, 10, 9, 8, 7, 6, 5, 4, 3, 2, and/or 1 seconds. Elements of a peak enhancement and detection algorithm for QRS peaks identification in ECG waveforms can be included. Referring to FIG. 2, shown is a flow chart illustrating an example of the application of elements of a peak enhancement and detection algorithm that can be utilized in accordance with various embodiments of this disclosure.

**[0049]** Signal  $y(t)$  is first passed through a digital differentiator to apply a derivative operation **203**. This step can help sharpen the peaks in  $y(t)$ . The resulting signal  $z(t)$  then goes through processing circuitry that can apply a squaring operation **206** and an averaging operation **209** to reform peaks in the output signal  $x(t)$ . The extracted peaks in  $x(t)$  can then be located. For example, the extracted peaks in  $x(t)$  can be located by an adaptive thresholding method such as that discussed in "A real-time QRS detection algorithm" by Pan et al. (*IEEE Trans. Biomed. Eng.*, vol. 32, no. 3, pp. 230-6, March 1985), which is hereby incorporated by reference in its entirety. Alternative embodiments can utilize the derivative operation **203** and the squaring operation **206**, without the averaging operation **209**; utilize the squaring operation **206** and the averaging operation **209**, without

using the derivative operation 203; or use the derivative operation 203 and averaging operation 209, without using the squaring operation 206.

[0050] Referring now to FIG. 3, shown is a block diagram illustrating an example of vital sign estimation in accordance with a various embodiments of the present disclosure. In the example of FIG. 3, two Tompkins peak detection blocks (block A and block B) 303 and 306 are implemented separately for detecting respiration peaks and heartbeat peaks. Other embodiments can utilize block A 303 and not block B 306, or utilize block B 306 and not block A 303. As shown in FIG. 3, by first band pass filtering 309 (e.g., a 0.8-2 Hz passband) the baseband radar signal B(t) to depress the low frequency DC drift and high frequency noise, the signal-to-noise ratio of the respiration harmonics within B(t) can be enhanced, which can improve respiration peaks detection. Other embodiments can use a different band for the band pass filter 309, apply a high pass filter (e.g., greater than 0.8 Hz), apply a low pass filter (e.g., less than 2 Hz), apply a combination of filters (e.g., high, low, and/or band pass filters), or apply no filtering. The Tompkins block A 303 in FIG. 3 is used to locate the respiration peaks with the adaptive thresholding method. The located respiration peaks can then be used to separate the baseband signal B(t) into segments (segmentation 312) for polynomial fitting and subtraction 315. After the subtraction of the respiration signal at 315, the remaining signal, which contains the heartbeat pulses, can be passed through another band pass filter 318 (e.g., a 3.5-10 Hz passband) to enhance the signal noise ratio of the heartbeat. Again, other embodiments can use alternative filtering as discussed above or no filtering. The remaining signal containing the heartbeat pulses can then be processed by the Tompkins peak detection block B 306 shown in FIG. 3 for heartbeat peaks detection. The extracted respiration and heartbeat peaks are sent from the Tompkins peak detection blocks (block A and block B) 303 and 306 to the sequential block for respiration and heart rates estimation 321.

[0051] Referring now to FIG. 4, shown is the result of respiration peaks detection and polynomial fit on the baseband signal B(t) 403, where the distance between the radar 103 (FIG. 1) and the subject 109 (FIG. 1) is 1 meter during the measurement. The Tompkins block A 303 (FIG. 3) locates the positive peaks 406 and negative peaks 409 in the respiration movements. By estimating the time intervals between the positive peaks 406, the respiration rate can be estimated 321 (FIG. 3). In some embodiments, the respiration rate can be estimated 321 in a variety of manners such as, but not limited to: estimating the time interval between a positive peak 406 and a negative peak 409; estimating the time intervals between the negative peaks 409; averaging the estimate of time intervals between positive peaks 406 and the estimate of time intervals between negative peaks 409; averaging the estimates of time intervals between positive peaks 406 over a certain number of adjacent positive peaks 406; averaging the estimates of time intervals between negative peaks 409 over a certain number of negative peaks 409; or other manners of combining the information regarding the location of the positive peaks 406 and/or negative peaks 409.

[0052] In one embodiment, among others, the band pass baseband signal B(t) 403 is separated into segments 312 (FIG. 3) using the located respiration peaks. The signal between consecutive respiration peaks (either positive peaks

406 or negative peaks 409) can be regarded as a segment and fitted 315 (FIG. 3) by a third degree polynomial under a Least Mean Square (LMS) standard. The resulting polynomial fit data 412 can then be subtracted 315 from the baseband signal B(t) 403, to create a remaining signal 415 comprising the heartbeat pulses and noise. Other degree polynomial fits (other than a third degree polynomial fit) can also be used, as can other curve fitting techniques.

[0053] Other techniques can be used to determine an approximation of the first vibration, which is to be subtracted 315 (FIG. 3) from the signal representative of the reflected signal R(t), such as B(t) 403, to produce the remaining signal 415. Such techniques to determine an approximation of the first vibration include, but are not limited to, measuring the respiration signal (as the first vibration) via video, via another radar signal, with the same or different wavelength, or by sending a radar signal at markers on the target. In the example of FIG. 3, the remaining signal 415 can then be processed by another band pass filter 318. The passband of the filter 318 can be experimentally set. In the example of FIG. 3, the passband filter 318 is set as 3.5-10 Hz, however other passbands can be used. For instance, the passband filter can be set so as to maximize the signal-to-noise ratio for heartbeat detection. The filtered signal can then be sent to Tompkins block B 306 for heartbeat peaks extraction and detection.

[0054] FIGS. 5A-5C show examples of how the heartbeat peaks can be extracted from the remaining baseband signal by applying the Tompkins peak detection. FIG. 5A shows the remaining signal after respiration movement subtraction 315 (FIG. 3) and band pass filtering 318 (FIG. 3). As shown in FIG. 5A, the heartbeat signal level is low and the heartbeat pulses are not obvious in the remaining band passed signal. In some embodiments, a derivative operation 203 (FIG. 2) can be applied to the remaining band passed signal, such as the remaining band passed signal shown in FIG. 5A. The signal remaining after the derivative operation 203 can then be operated on to take an absolute value or square, cube, or raise the signal by a larger exponent, or other operation, to enhance the difference between positive absolute values and zero.

[0055] FIG. 5B shows the result of an embodiment after a derivative operation 203 and a squaring operation 206 is applied. The remaining signal after the squaring operation 206, or other operation, can then be processed to extract the heartbeat pulses, or the time interval between adjacent heartbeat pulses. Such processing can count the number of local maxima's per a certain length of time and divide the length of time by the count to arrive at an averaging time period between heart beat pulses, which can be used to determine the heart rate. In some embodiments, averaging 209 (FIG. 2) can be applied.

[0056] Referring now to FIG. 5C, shown is a comparison between the signal 503 after the averaging operation 209 (FIG. 2) and the reference heartbeat pulses 506 from a contact sensor. The heartbeat pulses can be highlighted from the background noise. This can be confirmed by comparing the extracted heartbeat pulses 503 to the reference heartbeat pulses 506 also shown in FIG. 5C. The reference pulses 506 shown in FIG. 5C were recorded by a contact sensor (e.g., a piezoelectric pulse transducer) attached to the finger of the subject 109 (FIG. 1) during the experiment and are offset in FIG. 5C for the convenience of comparison. Similar to the

estimation of the respiration rate, the heartbeat rate can be estimated by calculating the intervals between heartbeat peaks.

**[0057]** In one embodiment, the heart rate can be estimated by estimating the time intervals between the positive peaks. In alternative embodiments, the heart rate can be estimated in a variety of manners, such as, but not limited to: estimating the time interval between a positive peak and a negative peak; estimating the time intervals between the negative peaks; averaging the estimate of time intervals between positive peaks and the estimate of time intervals between negative peaks; averaging the estimates of time intervals between positive peaks over a certain number of adjacent positive peaks; averaging the estimates of time intervals between negative peaks over a certain number of negative peaks; or other manners of combining the information regarding the location of the positive and/or negative peaks.

**[0058]** Referring next to FIG. 6, shown is a comparison between the real time heart rate **603**, which was estimated using the vital sign extraction and estimation described above, and the reference heart rate **606** that was monitored using the contact fingertip sensor that produced the reference heart beat signal shown in FIG. 5C. From FIG. 6 it can be seen that, in a 30 second measurement period, the vital sign acquisition provides a first heart rate estimation **603** within 5 seconds (using 4 consecutive heartbeat pulses with similar amplitude), which is much faster than previously reported methods (e.g., using the RELAX algorithm). Other embodiments can use more than 4 consecutive heart beat pulses and achieve a greater accuracy, or use less than 4, such as 3 or 2 consecutive heart beat pulses, and produce a heart rate estimation in a shorter time. The estimation of heart rate shown in FIG. 6 appears to accurately track with the reference data.

**[0059]** Experiments with three subjects (two adult males and one adult female) were conducted to verify the performance of the vital sign acquisition. Each measurement was at least 40 seconds long and multiple measurements are taken on each subject. Table I in FIG. 7 illustrates the statistics of Root Mean Square (RMS) error of the measurements. The results show that the vital sign acquisition can provide fairly accurate estimates of heart rate, such that the RMS error was less than 5 bpm for the three subjects. From FIG. 6 it can be seen that, by evaluating the heart rate from heartbeat intervals, the vital sign acquisition is able to provide the subject's short-term heart rate variation.

**[0060]** Fast vital sign acquisition based on Tompkins peak detection and segmented polynomial fitting strategy has been presented. By fitting and subtracting respiration movements from radar baseband signal and conducting peaks enhancing and detection processing, real time heartbeat pulse extraction can be achieved from radar signals. By estimating the intervals of respiration peaks and heartbeat peaks, the analysis is able to provide a fast estimation of a subject's vital sign information. Although embodiments are taught using a third degree polynomial fit, a polynomial fit other than a third degree polynomial fit can be used. Further, embodiments can utilize other curve fit(s).

**[0061]** Next, a portable Doppler radar system for fast vital sign acquisition is presented. The hardware platform of the system can use a coupler to separate the transmitting and receiving (TX/RX) radar signals from the same antenna. This implementation can help to reduce the hardware size. The system can also feature an automatic gain control baseband amplifier for making measurements under different distances. The fast acquisition algorithm can be designed to shorten the sensor's measuring time. The algorithm can depress the respiration signal with polynomial fitting and extract the heartbeat pulses in time domain. An accurate

estimation of subjects' physiology information can be achieved within a short measurement window by detecting the peaks of the processed respiration and heartbeat signals. The vital sign sensor can use a wireless communication module for transmitting measurement data. It can be packaged into a 60 mm×35 mm×30 mm box and powered by batteries to achieve great mobility.

**[0062]** The bulky, heavy, and expensive waveguide components used to implement radar sensors can limit their use to research environments. For applications such as battlefield first aid, earthquake rescue, and in-home health monitoring, various constraints should be considered to make a vital sign radar sensor serve better for the application scenarios. For the hardware aspect, the sensor system should be compact to make it easy to carry and deploy. It is also desirable for the system to adapt to the environmental changes and provide good measurement results under different measuring ranges. The algorithm for measurements should be able to estimate the subjects' physiology information within a short time, allowing the fast response sensor to save time in applications like disaster rescue and surveillance. A sensor that can provide a quick reading is also more user-friendly for healthcare monitoring. Besides, the vital sign acquisition should be able to separate the heartbeat signal effectively from the respiration signal, or other signals, to provide accurate heart rate estimation

**[0063]** Referring to FIG. 8, shown is an example of a continuous wave (CW) Doppler radar **103** for non-contact vital sign detection. The CW Doppler radar **103** can send out a single tone sinusoidal transmission signal  $T(t)$  of equation (1) via the transmitting (TX) antenna **112a**, which can be given by:

$$T(t) = A_t \cos(\omega t + \phi(t)), \quad (7)$$

where  $\phi(t)$  is the phase noise of the voltage controlled oscillator (VCO) of the radar system **103** and  $A_t$  is the amplitude of the transmitted waveform. The signal  $T(t)$  hits the front chest of the subject **109** and is reflected back to the radar sensor **112b**.

**[0064]** The backscattered signal  $R(t)$  of equation (2) is received by the radar sensor **112b**, and can be represented as:

$$R(t) = A_r \cos(\omega(t-t_d) + \phi(t-t_d) + \theta), \quad (8)$$

where  $\theta$  is phase change due to the reflection and  $t_d$  is the time delay introduced by the transmission of radar signal as given by equation (3). The distance,  $d$ , between the radar **103** and the subject **109** can be represented by equation (4). The backscattered signal  $R(t)$  can be rewritten in the following form:

$$R(t) = I(t) \cos(\omega t + \phi(t)) + Q(t) \sin(\omega t + \phi(t)), \quad (9)$$

where

$$I(t) = A_I \cos\left(\frac{4\pi d}{\lambda} - \Delta\phi - \theta\right), \quad (10)$$

$$Q(t) = A_Q \sin\left(\frac{4\pi d}{\lambda} - \Delta\phi - \theta\right), \quad (11)$$

and  $\Delta\phi = \phi(t-t_d) - \phi(t)$  is the difference of phase noise from the VCO. For short distance measurements (e.g.,  $d < 2$  m), the phase noise of the oscillator is highly correlated in time and can be approximated as a low frequent signal. Thus,  $\Delta\phi = \phi(t-t_d) - \phi(t) \approx 0$ . Ignoring the demodulation imbalance,  $A_I \approx A_Q = A_B$ . By demodulating  $R(t)$  with the same VCO used

for transmission, the signals  $I(t)$  and  $Q(t)$  can be retrieved. The baseband signal  $B(t)$  can be attained by combining  $I(t)$  and  $Q(t)$  such that:

$$B(t) = I(t) + jQ(t) = A_B \exp\left(j\left(\frac{4\pi d_0}{\lambda} - \theta\right)\right) \exp(j(4\pi x_h(t) + 4\pi x_r(t))/\lambda). \quad (12)$$

The phase of  $B(t)$  contains the movements relating to the vital activities of the subjects.

[0065] The hardware platform of the vital sign radar system 103 can be designed for portable applications. Referring to FIG. 9, shown is a block diagram of an example of the portable radar system 103 for vital sign detection, which is implemented by two modules: a radio frequency (RF) module 903 and a baseband module 906.

[0066] For the RF module 903, a T-model branch-line coupler 909 can be implemented on a printed circuit board (PCB) so that the sensor can use the same antenna 112 for transmitting and receiving the RF signals (e.g., at 5.8 GHz). This can help reduce the size of the detection system. For the baseband module 906, a variable gain amplifier (VGA) 912 can be implemented to amplify in-phase and quadrature (I/Q) signals with the proper gain. The VGA 912 can allow the system adapt to different acquisition distances. Besides, a ZigBee wireless module 915 can be integrated on board to transmit the I/O data to a PC 918 for signal processing. FIG. 10 is an image of an implemented radar sensor in a 60 mm×35 mm×15 mm plastic box. The hardware platform can be sealed in the plastic box and powered by a battery. The detection system offers a compact size and good mobility, which makes it suitable as a portable device for non-contact vital sign detection.

[0067] T-model branch-line coupler. The T-model branch-line coupler 909 can be implemented on the PCB to separate the transmitting and receiving RF signals 106 and 115. FIG. 11 is an image of an example of a T-model branch-line coupler 909. With the coupler 909, the radar system 103 can use one antenna 112 for TX/RX instead of using two separated antennas in its RF front end. At 5.8 GHz, the typical size of a 2×2 patch array antenna is 70 mm×70 mm as shown in FIG. 12A, which is much bigger than the size of the coupler (12.8 mm×10.3 mm). The coupler 909 can reduce the size of the hardware platform by using the same antenna 112 for both RF signal transmission and reception.

[0068] Automatic gain controlled baseband amplifier. The distance between the subject 109 (FIG. 8) and the radar sensor 112 can vary across the measurements. Different measurement distances can cause different strengths of the backscattered signal 115 (different  $A_r$  in equation (8)). This will lead to different amplitudes of the demodulated I/Q signal ( $A_I$  in equation (10) and  $A_Q$  in equation (11)). A fixed gain baseband amplifier cannot adjust its gain according to the variation of signal strength, since it would either cause signal saturation or insufficient amplification of the I/Q signals. So the sensor can provide an adjustable amplifying gain to avoid signal saturation while fully utilizing the dynamical range of the A/D converter. In the example of FIG. 9, a variable gain baseband amplifier 912 is implemented. A microcontroller unit (MCU) 921 (e.g., Texas Instruments MSP430) can be used to monitor the dynamic range of the I/O signals and adjust the gain of the baseband amplifier 912 to provide sufficient gain for amplification. FIG. 12A shows the front side view of the radar sensor

hardware including circuitry for the ZigBee module 915 and the antenna 112, and FIG. 12B shows the back side view of the radar sensor hardware including circuitry for the coupler 909, the baseband amplifier 912 and MCU 921.

[0069] Referring next to FIG. 13, shown is a block diagram illustrating an example of the automatic gain controlled baseband amplifier 912 controlled by the MCU 921. The baseband amplifier 912 can be implemented by cascading four operational amplifier stages 1303. Each stage 1303 provides a fixed gain for amplifying I/O signals. The four outputs (X1 to X4 in FIG. 13) of the baseband amplifier can provide separate gains of 5×, 10×, 20×, and 100×. A multiplexer 1306 controlled by MCU 921 (MSP430) is used to select the signal from the four outputs (X1 to X4 in FIG. 13) for analog-to-digital (A/D) sampling 1309.

[0070] The MCU 921 can be programmed to monitor the dynamic range of the output of the amplifier 912 and adjust its gain to avoid baseband signal saturation. FIG. 14 shows a flow chart illustrating an example of the automatic gain control. Beginning with 1403, the MCU 921 buffers an 8-second I/O data sample from the output of the amplifier 912 and tracks the dynamical range of the signals within the buffered window. At 1406, the MCU 921 determines if the I/O data is saturated or not. If the MCU 921 detects that the I/O signals are getting saturated after the amplification, the MCU 921 can decrease the gain to a lower level at 1409. If the dynamic range of the signal is too small, the MCU 921 can provide a control signal that will boost the gain of the amplifier 912 by switching to an amplifier stage with larger gain. This can be accomplished by updating the buffer at 1412 and calculating the dynamic range within the buffer at 1415. If an increase in the gain would cause saturation at 1418, then the gain is kept the same at 1421. If the increase would not result in saturation at 1418, then the gain is increased at 1424. The flow can return to 1403 to continue monitoring the output of the amplifier 912. Using this automatic gain control mechanism, the baseband module 906 can adapt itself to different measurement distances and/or different signal strengths.

[0071] An algorithm can be implemented for fast vital sign acquisition which can be executed on a computing device such as the PC 918 of FIG. 9 to process the I/Q data sent from the portable radar sensor. The vital sign acquisition can effectively separate the heartbeat signal from the respiration signal. It can estimate one or more vital signs of the subject 109 by calculating the peak-to-peak intervals from the processed heartbeat and respiration waveforms.

[0072] Respiration rate estimation. Referring to FIG. 15, shown is a flow chart illustrating an example of estimating the respiration rate of a subject 109 (FIG. 9). The digitalized baseband signals  $I(n)$  and  $Q(n)$  can be demodulated into a phase signal  $S(n)$  using linear demodulation 1503. The signal  $S(n)$  can first go through a digital low pass filter 1506 to get  $S_{LP}(n)$ . A 3rd order Butterworth low pass filter with 1 Hz cutoff frequency can be used to depress high frequency noise and the heartbeat signal. The cutoff frequency is set to 1 Hz so that the typical respiration signal (e.g., a typical respiration rate of less than 60 bpm) can pass through. The filtered signal  $S_{LP}(n)$  is dominated by the fundamental harmonic of the respiration signal.

[0073] The  $S(n)$  and/or the  $S_{LP}(n)$  can be used by the peak detection 1509 to detect respiration peaks. The respiration rate is estimated 1512 with the peak-to-peak intervals of the respiration waveform. As shown in FIGS. 16A and 16B, the

peak detection **1509** for the respiration signal can be based on the filtered waveform  $S_{LP}(n)$  **1603** and the radar waveform  $S(n)$  **1606**. The peak detection **1509** first detects the negative peaks **1609** on the filtered signal  $S_{LP}(n)$  with a three-point peak detection method. Since high frequency noise and heartbeat signals have been filtered out from  $S_{LP}(n)$ , the peak detection **1509** on  $S_{LP}(n)$  is more reliable. **[0074]** Thresholding can be used to remove the detected low amplitude peaks caused by noise. The peaks **1609** detected in  $S_{LP}(n)$  are then used to locate the respiration peak locations **1612** in  $S(n)$ . The negative respiration peaks **1612** are regarded as the local minima points of  $S(n)$  within the 0.5-second detection window. The detection window is right in front of the peaks **1609** from  $S_{LP}(n)$  as illustrated in FIG. **16B**. By using both the filtered signal  $S_{LP}(n)$  **1603** and the radar signal  $S(n)$  **1606** for peak detection, the peak detection is able to avoid high frequency noise peaks and accurately locate the respiration peaks **1612**. The detected negative peaks **1612** can be used to estimate the respiration rate of the subject.

**[0075]** Heart rate estimation. FIG. **17** shows a flow chart illustrating an example of estimating the heart rate of the subject. First, the respiration signal in  $S(n)$  **1606** is fit and subtracted away at **1703**. The remaining signal is then passed through digital bandpass filtering **1706** and Tompkins peak enhancement **1709** to extract and enhance the heartbeat pulses. After heartbeat pulses are extracted, peak detection **1712** is used to detect the locations of heartbeat peaks for heart rate estimation **1715**. The fitting degree can also be adaptively changed **1718** to improve the quality of extracted heartbeat pulses.

**[0076]** Depression of respiration signal. The baseband radar waveform  $S(n)$  **1606** can be presented as:

$$S(n) = X_r(n) + X_h(n) + N(n), \quad (13)$$

where  $X_r(n)$  is the respiration signal,  $X_h(n)$  is the heart rate signal and  $N(n)$  is the noise. For subjects **109** (FIG. **1**) that are sitting still, the amplitude of the heartbeat vibration on front chest is on the order of 0.1 mm while the amplitude of respiration varies from about 4 mm to about 12 mm. Generally, the respiration signal  $X_r(n)$  is not a single tone signal but a signal with strong higher order harmonics. The higher order harmonics of  $X_r(n)$  can be stronger than the fundamental tone of heartbeat. In spectrum analysis, the higher order components of the respiration can smear or even overwhelm the heartbeat signal, causing error for heart rate estimation. Besides, the respiration movement of a subject **109** may not be strictly periodic. These can cause estimation errors for methods based on FFT spectrum analysis.

**[0077]** A Least Mean Square (LMS) method can be used to estimate the respiration signal. Since the respiration component is much stronger than the heartbeat component ( $X_r(n) \gg X_h(n)$ ), the fitted result  $\overline{X}_r(n)$  **1803** will be dominated by  $X_r(n)$ . Thus, by subtracting the fitted waveform  $\overline{X}_r(n)$  from  $S(n)$  **1606**, a large fraction of respiration waveform  $X_r(n)$  (e.g., its fundamental and higher order harmonics) can be depressed.

**[0078]** The procedure for LMS fitting on the signal  $S(n)$  **1606** can be illustrated using FIG. **18A**. Each respiration period can be separated into three segments ( $S_1$ ,  $S_2$ , and  $S_3$  in FIG. **18A**) using the detected respiration peaks **1809**. The segments  $S_1$ ,  $S_2$ , and  $S_3$  shown in FIG. **18A** can then be fit separately with polynomial curves. The segmentation on the

signal is to make the fitting more robust against the non-periodical respiration movements.

**[0079]** Let  $S_i(n)$   $i=1,2,3$  represent the data of the three segments in FIG. **18A**, and let:

$$\begin{aligned} S_1 &= [S(n_1) S(n_1+1) \dots S(n_3)]^T, \\ S_2 &= [S(n_3) S(n_3+1) \dots S(n_4)]^T, \\ S_3 &= [S(n_4) S(n_4+1) \dots S(n_5)]^T, \end{aligned} \quad (14)$$

where  $n_1 < n_2 < n_3 < n_4 < n_5$ . Let:

$$A_1 = \begin{bmatrix} 1 & n_1 & n_1^2 & \dots & n_1^K \\ 1 & n_1+1 & (n_1+1)^2 & \dots & (n_1+1)^K \\ \vdots & \vdots & \vdots & \ddots & \vdots \\ 1 & n_3 & n_3^2 & \dots & n_3^K \end{bmatrix}^T, \text{ and} \quad (15)$$

$$\vec{a} = [a_0 \ a_1 \ \dots \ a_K]^T. \quad (16)$$

where  $K$  is the order of the polynomial curve for fitting. With the LMS method, the coefficients of the fitted curve for  $S_1$  can be determined as:

$$\vec{a} = (A_1^T A_1)^{-1} A_1^T S_1, \quad (17)$$

and the fitted data is given by:

$$\overline{S}_1 = A_1 * \vec{a} \quad (18)$$

Similarly, we can get  $\overline{S}_2$  and  $\overline{S}_3$  from  $S_2$  and  $S_3$ .  $\overline{S}_1$ ,  $\overline{S}_2$  and  $\overline{S}_3$  can then be merged together to get the fitted result  $\overline{S}_{seg}$  of the respiration period:

$$\overline{S}_{seg}(n) = (1-w_1) * [\overline{S}_1, \overline{S}_2] + w_1 * \overline{S}_3, \quad (19)$$

where

$$\overline{S}_3'(n) = \begin{cases} \overline{S}_3(n) & \text{for } n = n_2 \dots n_3 \\ 0 & \text{otherwise} \end{cases}, \quad (20)$$

$$w_1(n) = \begin{cases} \frac{n-n_2}{n_3-n_2} & \text{for } n = n_2 \dots n_3 \\ \frac{n_4-n}{n_4-n_3} & \text{for } n = n_3+1 \dots n_4 \\ 0 & \text{otherwise} \end{cases}, \quad (21)$$

$\overline{S}_{seg}(n)$  for different respiration periods are then conjunct together to get the estimated respiration waveform  $\overline{X}_r(n)$ .

**[0080]** It can be seen from FIG. **18B** that the fitted signal  $\overline{X}_r(n)$  **1803** follows the trend of respiration in  $S(n)$  **1606** while ignores the small ripples due to heartbeats. The estimated respiration component  $\overline{X}_r(n)$  **1803** can then be subtracted from  $S(n)$  to depress the respiration signal. The remaining signal of:

$$R(n) = S(n) - \overline{X}_r(n) \quad (22)$$

represents the heartbeat pulses, the fitting error, and high frequency noise.

**[0081]** Band pass filtering. After the cancellation of the respiration signal, the remaining signal  $R(n)$  is filtered via a band pass filter **1706** (FIG. **17**) such as, e.g., a 3.5 Hz to 12 Hz passband. The band pass filtering **1706** can depress high frequency noise and the fundamental harmonic of the heartbeat signal  $X_h(n)$ . Higher order harmonics of  $X_h(n)$  can be used for fast heart rate estimation. The reason of using

higher order harmonics instead of the fundamental harmonic for heart rate estimation can be understood by analyzing the uncertainty principle. For a heartbeat signal  $X_h(n)$  with a fundamental frequency  $f_{heart}$ , if it is estimated with a T-second measurement window, the FFT spectrum resolution will be:

$$\Delta f = 1/T. \quad (23)$$

So if the estimation of the heart rate is based on its fundamental harmonic, a short measurement time T will lead to worse accuracy (or a bigger  $\Delta f$  in equation (23)). In this case, accurate heart rate estimation within a short time is not possible. However, if the algorithm is based on the Nth order harmonic of the heartbeat signal with frequency  $f_{Nheart} = N * f_{heart}$ . For a T-second measurement, the uncertainty for  $f_{Nheart}$  in the spectrum will be:

$$\Delta f_{Nheart} = 1/T' \quad (24)$$

and since:

$$f_{heart} = f_{Nheart}/N \quad (25)$$

the uncertainty of  $f_{heart}$  becomes:

$$\Delta f_{Nheart} = \Delta f_{Nheart}/N = 1/N T. \quad (26)$$

Thus, methods based on higher order harmonics for heart rate estimation can get a better accuracy for a short time measurement.

**[0082]** Tompkins's method for heartbeat pulses extraction. After the bandpass filtering **706**, the filtered signal  $y(n)$  can be enhanced via Tompkins's method **1709** (FIG. 17). The method **1709** enhances the heartbeat signal via steps including derivative, square, and averaging operations as illustrated in FIG. 2. Tompkins's method first calculates the derivative of signal  $y(n)$  at **203** by:

$$z[n] = \frac{f_s}{8} * \{-y[n-2] - 2y[n-1] + 2y[n+1] + y[n+2]\}, \quad (27)$$

where  $f_s$  is the sample rate of the data. Then,  $z[n]$  can be used to calculate a squared waveform  $a[n]$  at **206** by:

$$a[n] = y[n]^2. \quad (28)$$

The averaged **209** waveform  $x[n]$  can be derived at **209** from  $a[n]$  by averaging  $a[n]$  with a 0.3 second window:

$$x[n] = \frac{1}{0.3 * f_s} \sum_{i=n-1}^{n+0.3 * f_s} a[i]. \quad (28)$$

Waveforms in each step of Tompkins's method can be seen in FIGS. 19A-19D. FIG. 19A shows an example of the waveform  $R(n)$  after subtraction, FIG. 19B shows an example of the bandpass filtered waveform  $y(n)$ , FIG. 19C shows an example of the squared waveform  $a(n)$ , and FIG. 19D shows an example of the averaged waveform  $x(n)$ . By using the Tompkins's method, the heartbeat pulses in  $y(n)$  can be enhanced for heartbeat peak detection.

**[0083]** If the quality of extracted heartbeat pulses is not good enough for accurate heart rate estimation (e.g., the variance of peak-to-peak intervals in the averaged waveform  $x[n]$  is above a preset threshold), the algorithm can redo the depression of respiration signal, band pass filtering, and

Tompkins's method for heartbeat pulses extraction described above with higher order polynomial curves to improve the signal quality.

**[0084]** Peak detection for heartbeat signal. The heartbeat peaks detection **1715** (FIG. 17) can be based on the squared waveform  $a[n]$  and the averaged waveform  $x[n]$ . FIG. 20 illustrates the peaks detection using squared waveform  $a[n]$  and averaged waveform  $x[n]$ . Since low energy noise spikes are depressed by averaging **209** (FIG. 2), the peak detection on  $x[n]$  is less sensitive for high frequency noise. But the heartbeat peaks in  $x[n]$  are smooth peaks with poor time resolution. The squared waveform  $a[n]$  in FIG. 19C in contrast has many noise peaks, even though it has a good time resolution. So both  $a[n]$  and  $x[n]$  can be used to reliably detect the accurate locations of heartbeat peaks. Once the peaks are located in averaged waveform  $x[n]$ , the heartbeat peaks in  $a[n]$  can be detected as the local maximal point within a detection window. The detection window can be a 0.3-second time slot right before the detected peaks in averaged waveform  $x[n]$  as shown in FIG. 20. The heart rate can then be estimated via the peak-to-peak intervals.

**[0085]** During the measurements, the subjects **109** sat 0.6 meter away from the vital sign radar **103** and were directed to keep their bodies still and breathe regularly. The sensor was adjusted to the height of the subjects' sternum for a better signal quality. A MEMS sensor (e.g., model sq-xld-3x) was affixed to the subjects' front chest for reference respiration measurements. A contact sensor (e.g., a model **1010** piezoelectric pulse transducer) was attached to the subjects' finger to provide the reference heart rate signal.

**[0086]** Both the respiration and heartbeat measurement results are presented. The time windows for estimating heart rate and respiration rate were different. For heart rate estimation, a 5 second window was used and for the respiration rate, the window length was extended to 10 seconds. The extension was due to the fact that the respiration is a low frequency signal (e.g., 0.15 to 0.4 Hz).

**[0087]** Respiration measurement. Referring to FIGS. 21A and 21B, shown are the respiration waveforms from the radar sensor and the MEMS sensor, respectively. The respiration rate can be estimated with the peak detection method discussed above. The algorithm can use a 10-second window to estimate respiration rate from both waveforms. The peak-to-peak intervals within the windows can be averaged for the respiration rate estimation. FIG. 22 shows the comparison of the respiration rates estimated by the radar sensor **2203** and the MEMS sensor **2206**. The averaged difference of the measurements from the two sensors is 0.26 beat-per-minute (bpm) with a standard derivation of 0.543 bpm. The measurement shows that the radar sensor can provide an accurate measurement of the subject's respiration rate when compared to the reference MEMS sensor.

**[0088]** Heart rate measurement. Referring to FIG. 23, shown is a comparison between the reference heart rate **2303** and the heart rate estimated via the radar sensor **2306**. The sensor can use a 5-second measuring window for heart rate estimation. The short measurement window allows the sensor to have a quicker response for subjects' heart rate variation. The detected peak-to-peak heartbeat intervals within the window can be averaged for the heart rate estimation **2306**. FIG. 23 shows traces corresponding to reference heart rate **2303** (estimated via the contact sensor) and reference heart rate  $\pm 2$  bpm (RHR $\pm$ -2) for comparison. Both the estimated heart rate **2306** and the reference heart

rate **2303** were calculated with a 2-second incremental step size in the measurement. The averaged difference between the estimations from the two sensors is 0.52 bpm with a standard derivation of 1.84 bpm. It can be observed from FIG. **23** that the fast time domain algorithm can accurately estimate heart rate with a short measurement window. It can also reflect the short period heart rate variation like the contact sensor.

[**0089**] Referring now to FIG. **24**, shown is an example of a system **2400** that may be utilized in non-contact monitoring of vital signs. The system **2400** includes one or more computing device(s) **2403**, one or more radar system(s) **103** that can provide non-contact measurement indications as previously discussed. For example, the radar system(s) **103** can monitor vibrations of a target subject such as a patient, or other individual or animal.

[**0090**] The computing device **2403** includes at least one processor circuit, for example, having a processor **2409** and a memory **2412**, both of which are coupled to a local interface **2415**. To this end, the computing device(s) **2403** may comprise, for example, a server computer or any other system providing computing capability. The computing device(s) **2403** may include, for example, one or more display devices such as cathode ray tubes (CRTs), liquid crystal display (LCD) screens, gas plasma-based flat panel displays, LCD projectors, or other types of display devices, etc. The computing device(s) **2403** may also include, for example various peripheral devices. In particular, the peripheral devices may include input devices such as, for example, a keyboard, keypad, touch pad, touch screen, microphone, scanner, mouse, joystick, or one or more push buttons, etc. Even though the computing device **2403** is referred to in the singular, it is understood that a plurality of computing devices **2403** may be employed in the various arrangements as described above. The local interface **2415** may comprise, for example, a data bus with an accompanying address/control bus or other bus structure as can be appreciated.

[**0091**] Stored in the memory **2412** are both data and several components that are executable by the processor **2409**. In particular, stored in the memory **2412** and executable by the processor **2409** include a vital sign estimation application **2418** and potentially other applications. Also stored in the memory **2412** may be a data store **2421** and other data. The data stored in the data store **2421**, for example, is associated with the operation of the various applications and/or functional entities described below. For example, the data store may include sample analysis results, corrective measures, and other data or information as can be understood. In addition, an operating system **2424** may be stored in the memory **2412** and executable by the processor **2409**. The data store **2421** may be located in a single computing device or may be dispersed among many different devices.

[**0092**] The radar system **103** is representative of a plurality of devices that may be communicatively coupled to the computing device **2403** either directly through a wired or wireless connection such as, e.g., Zigbee® or Bluetooth®, or through a network **2427** such as, e.g., the Internet, intranets, extranets, wide area networks (WANs), local area networks (LANs), wired networks, wireless networks, or other suitable networks, etc., or any combination of two or more such networks. The radar system **103** may comprise, for example, a processor-based system such as a processing

system or other application specific system with communication capabilities. In some embodiments, a radar system **103** may be directly connected to the computing device **2403**.

[**0093**] The components executed on the computing device **2403** include, for example, the vital sign estimation application **2418** and other systems, applications, services, processes, engines, or functionality not discussed in detail herein. The computing device **2403** can receive information regarding the monitored subject from a radar system **103**, which can then be evaluated by the vital sign estimation application **2418**.

[**0094**] It is understood that there may be other applications that are stored in the memory **2412** and are executable by the processor **2409** as can be appreciated. Where any component discussed herein is implemented in the form of software, any one of a number of programming languages may be employed such as, for example, C, C++, C#, Objective C, Java, Java Script, Perl, PHP, Visual Basic, Python, Ruby, Delphi, Flash, or other programming languages.

[**0095**] A number of software components are stored in the memory **2412** and are executable by the processor **2409**. In this respect, the term “executable” means a program file that is in a form that can ultimately be run by the processor **2409**. Examples of executable programs may be, for example, a compiled program that can be translated into machine instructions in a format that can be loaded into a random access portion of the memory **2412** and run by the processor **2409**, source code that may be expressed in proper format such as object code that is capable of being loaded into a random access portion of the memory **2412** and executed by the processor **2409**, or source code that may be interpreted by another executable program to generate instructions in a random access portion of the memory **2412** to be executed by the processor **2409**, etc. An executable program may be stored in any portion or component of the memory **2412** including, for example, random access memory (RAM), read-only memory (ROM), hard drive, solid-state drive, USB flash drive, memory card, optical disc such as compact disc (CD) or digital versatile disc (DVD), floppy disk, magnetic tape, or other memory components.

[**0096**] The examples of FIGS. **2**, **3**, **15** and **17** show aspects of the architecture, functionality, and operation of a possible implementation of the vital sign estimation application. In this regard, each block can represent a module, segment, or portion of code, which comprises one or more executable instructions for implementing the specified logical function(s). It should also be noted that in some alternative implementations, the functions noted in the blocks may occur out of the order noted in FIGS. **2**, **3**, **15** and **17**. For example, two blocks shown in succession in FIGS. **2**, **3**, **15** and **17** may in fact be executed substantially concurrently or the blocks may sometimes be executed in the reverse order, depending upon the functionality involved.

[**0097**] Also, the processor **2409** may represent multiple processors **2409** and the memory **2412** may represent multiple memories **2412** that operate in parallel processing circuits, respectively. In such a case, the local interface **2415** may be an appropriate network that facilitates communication between any two of the multiple processors **2409**, between any processor **2409** and any of the memories **2412**, or between any two of the memories **2412**, etc. The local interface **2415** may comprise additional systems designed to

coordinate this communication, including, for example, performing load balancing. The processor **2409** may be of electrical or of some other available construction.

**[0098]** Although the vital sign estimation application **2418**, and other various systems described herein, may be embodied in software or instructions executed by general purpose hardware as discussed above, as an alternative the same may also be embodied in dedicated hardware or a combination of software/general purpose hardware and dedicated hardware. If embodied in dedicated hardware, each can be implemented as a circuit or state machine that employs any one of or a combination of a number of technologies. These technologies may include, but are not limited to, discrete logic circuits having logic gates for implementing various logic functions upon an application of one or more data signals, application specific integrated circuits having appropriate logic gates, or other components, etc. Such technologies are generally well known by those skilled in the art and, consequently, are not described in detail herein.

**[0099]** Any logic or application described herein, including the vital sign estimation application **2418**, that comprises software or instructions can be embodied in any non-transitory computer-readable medium for use by or in connection with an instruction execution system such as, for example, a processor **2409** in a computer system or other system. In this sense, the logic may comprise, for example, statements including instructions and declarations that can be fetched from the computer-readable medium and executed by the instruction execution system. In the context of the present disclosure, a “computer-readable medium” can be any medium that can contain, store, or maintain the logic or application described herein for use by or in connection with the instruction execution system. The computer-readable medium can comprise any one of many physical media such as, for example, electronic, magnetic, optical, electromagnetic, infrared, or semiconductor media. More specific examples of a suitable computer-readable medium would include, but are not limited to, magnetic tapes, magnetic floppy diskettes, magnetic hard drives, memory cards, solid-state drives, USB flash drives, or optical discs. Also, the computer-readable medium may be a random access memory (RAM) including, for example, static random access memory (SRAM) and dynamic random access memory (DRAM), or magnetic random access memory (MRAM). In addition, the computer-readable medium may be a read-only memory (ROM), a programmable read-only memory (PROM), an erasable programmable read-only memory (EPROM), an electrically erasable programmable read-only memory (EEPROM), or other type of memory device.

**[0100]** A portable radar system for fast vital sign acquisition has been presented. Both hardware and software of the system were designed to optimize the sensor’s performance. The hardware platform of the system features a coupler **909** (FIG. 9) and an automatic gain controlled baseband amplifier **912** (FIG. 9). The hardware implementation makes the sensor compact and adapts to the variation of signal strength. A fast-acquisition algorithm was also designed for the system to shorten the system’s response time. The algorithm was able to depress the respiration signal with polynomial fitting and extract the heartbeat pulses for peaks detection measurement. Experimental results show that the system can accurately estimate the subjects’ physiology information

within short measurement time windows, reflecting the short period heart rate variation as the contact sensor.

**[0101]** Embodiments of the vital sign extraction and estimation can be advantageous when a first vibration, such as respiration, has an amplitude that is greater than 5, greater than 10, greater than 15, and/or greater than 20 times an amplitude of a second vibration, such as heartbeat. In addition to these amplitude ratios, various embodiments can have a vibration rate of the first vibration that is smaller than the vibration rate of the second vibration (e.g.,  $\frac{1}{2}$ ,  $\frac{1}{3}$ ,  $\frac{1}{4}$ , and/or  $\frac{1}{5}$  of the second vibration rate). The transmit antenna and the receive antenna can be located several radar signal wavelengths away from the target. How far the transmit antenna and receive antenna are away from the target can depend on the transmitted power and the focused beam width of the antenna. In one embodiment, among others, the detection distance can be greater than 0.3, 0.5, 1.0, 1.5, 2.0, 2.5, and/or 3.0 m with a transmission frequency of 5.8 GHz and transmission power of 10 mW.

**[0102]** Embodiments can be applied to more than 2 vibrations when the amplitudes and vibration rates in the time domain are different enough to allow for identification of the individual vibration signals.

**[0103]** Embodiments can utilize quadrature detection, which can avoid null points in the measurements. Further embodiments can utilize non-quadrature detection. In some embodiments, the I-channel, Q-channel, the better signal of the I and Q-channels, or some combination of the I-channel and Q-channel, can be used as the signal representative of the receive signal, and the subject method of analyzing the chosen signal to identify at least two adjacent peaks of the first vibration, separating the chosen signal into segments between the adjacent peaks, fitting a curve fit to the first vibration, subtracting the curve fit from the chosen signal to produce a remaining signal, processing the remaining signal, processing the remaining signal to produce a processed remaining signal, wherein peaks of the second vibration are enhanced in the processed remaining signal, analyzing the processed remaining signal to identify at least two adjacent peaks of the second vibration, and determining the second vibration rate from the at least two adjacent peaks of the processed remaining signal, can be performed on such signal representative of the receive signal.

**[0104]** Embodiments can estimate the time interval between peaks of one of the vibrations, and convert this to a vibration rate, as taught. In further embodiments, the vibration rate can be estimated by estimating the time difference between two or more points in the vibration cycle, such as the time difference between two rising edges, the time difference between two falling edges, or the time difference between two other locations on the vibration signal, taking into account the portion of the period of the vibration represented. These peaks or other locations can be identified after differentiating the waveform.

**[0105]** Embodiments can be implemented via a variety of radar systems, including the radar systems shown in FIG. 1 from U.S. Pat. No. 7,848,896, FIG. 1 from U.S. Pat. No. 7,903,020, and FIGS. 2 and 19 from published U.S. Patent Application No. 2013/0139597, which are all hereby incorporated by reference in their entirety for the purpose of teaching such systems.

**[0106]** Aspects of the present disclosure, such as signal transmission, signal detection, and signal processing, may be described in the general context of computer-executable

instructions, such as program modules, being executed by a computer. Generally, program modules include routines, programs, objects, components, data structures, etc., that perform particular tasks or implement particular abstract data types. Moreover, those skilled in the art will appreciate that aspects of the present disclosure may be practiced with a variety of computer-system configurations, including multiprocessor systems, microprocessor-based or program-mable-consumer electronics, minicomputers, mainframe computers, and the like. Any number of computer-systems and computer networks are acceptable for use with the present disclosure.

[0107] Specific hardware devices, programming languages, components, processes, protocols, and numerous details including operating environments and the like are set forth to provide a thorough understanding of the present disclosure. In other instances, structures, devices, and processes are shown in block-diagram form, rather than in detail, to avoid obscuring the present disclosure. But an ordinary-skilled artisan would understand that the present disclosure may be practiced without these specific details. Computer systems, servers, work stations, and other machines may be connected to one another across a communication medium including, for example, a network or networks.

[0108] As one skilled in the art will appreciate, embodiments of the present disclosure may be embodied as, among other things: a method, system, an apparatus, a device or computer-program product. Accordingly, the embodiments may take the form of a hardware embodiment, a software embodiment, or an embodiment combining software and hardware. In an embodiment, the present disclosure takes the form of a computer-program product that includes computer-useable instructions embodied on one or more computer-readable media.

[0109] It should be emphasized that the above-described embodiments of the present disclosure are merely possible examples of implementations set forth for a clear understanding of the principles of the disclosure. Many variations and modifications may be made to the above-described embodiment(s) without departing substantially from the spirit and principles of the disclosure. All such modifications and variations are intended to be included herein within the scope of this disclosure and protected by the following claims.

[0110] It should be noted that ratios, concentrations, amounts, and other numerical data may be expressed herein in a range format. It is to be understood that such a range format is used for convenience and brevity, and thus, should be interpreted in a flexible manner to include not only the numerical values explicitly recited as the limits of the range, but also to include all the individual numerical values or sub-ranges encompassed within that range as if each numerical value and sub-range is explicitly recited. To illustrate, a concentration range of “about 0.1% to about 5%” should be interpreted to include not only the explicitly recited concentration of about 0.1 wt % to about 5 wt %, but also include individual concentrations (e.g., 1%, 2%, 3%, and 4%) and the sub-ranges (e.g., 0.5%, 1.1%, 2.2%, 3.3%, and 4.4%) within the indicated range. The term “about” can include traditional rounding according to significant figures of numerical values. In addition, the phrase “about ‘x’ to ‘y’” includes “about ‘x’ to about ‘y’”.

1. A method of estimating a vibration rate of a target, comprising:

transmitting a transmit signal from a transmitting antenna at a target such that the transmit signal is reflected by the target to create a reflected signal, wherein the transmit signal and the reflected signal are electromagnetic signals having a wavelength,  $\lambda$ , where the transmit signal is represented as  $T(t)=\cos(\omega t+\phi(t))$  and the reflected signal is represented as  $R(t)=\cos(\omega(t-t_d)+\phi(t-t_d))$ , where  $t_d$  is a time period the transmit signal travels from the transmitting antenna to the target and the reflected signal travels from the target to the receiving antenna;

receiving the reflected signal via a receiving antenna to create a receive signal, wherein the target is vibrating with a first vibration at a first vibration rate and a first vibration amplitude, wherein the target is vibrating with a second vibration at a second vibration rate and a second vibration amplitude, wherein a transmit distance between the transmitting antenna and the target and a receive distance between the target and the receiving antenna are such that  $\phi(t-t_d)\approx\phi(t)$  and the receive signal is approximated as  $R(t)\approx I(t)\cos(\omega t+\phi(t))+Q(t)\sin(\omega t+\phi(t))$ , where  $I(t)=\cos(4\pi d/\lambda)$ ,  $Q(t)=\sin(4\pi d/\lambda)$ ;

determining an approximation of the first vibration from a signal representative of  $R(t)$ ;

subtracting the approximation of the first vibration from the signal representative of  $R(t)$  to produce a remaining signal;

processing the remaining signal to produce a processed remaining signal; and

analyzing the processed remaining signal to identify at least two occurrences of a known position on a cycle of the second vibration in the processed remaining signal corresponding to at least two occurrences of the known position on the cycle of the second vibration, wherein identification of occurrences of the known position on the cycle of the second vibration in the processed remaining signal is enhanced compared to identifying the remaining signal.

2. The method according to claim 1, further comprising: determining the second vibration rate from a corresponding at least two locations of the at least two occurrences of the known position on the cycle of the second vibration in the processed remaining signal.

3. (canceled)

4. The method according to claim 1, wherein determining an approximation of the first vibration from the signal representative of  $R(t)$  comprises:

analyzing the signal representative of  $R(t)$  to identify at least two occurrences of a known position on a cycle of the first vibration in the signal representative of  $R(t)$  corresponding to at least two occurrences of the known position on the cycle of the first vibration; and

separating the signal representative of  $R(t)$  into segments between locations of known positions on the cycle of the first vibration in the signal representative of  $R(t)$  of the at least two occurrences of the known position on the cycle of the first vibration in the signal representative of  $R(t)$  and fitting a curve fit to the first vibration, wherein the curve fit is the approximation of the first vibration.

5. The method according to claim 1, wherein the at least two occurrences of the known position on the cycle of the second vibration in the processed remaining signal are at least two peaks of the second vibration in the processed remaining signal.

6-8. (canceled)

9. The method according to claim 1, wherein analyzing the processed remaining signal to identify at least two occurrences of the known position on the cycle of the second vibration in the processed remaining signal corresponding to at least two occurrences of the known position on the cycle of the second vibration comprises analyzing the processed remaining signal to identify at least two adjacent occurrences of the known position on the cycle of the second vibration in the processed remaining signal corresponding to at least two adjacent occurrences of the known position on the cycle of the second vibration.

10. The method according to claim 2, wherein the at least two occurrences of the known position on the cycle of the second vibration are at least two occurrences of peaks of the second vibration, wherein analyzing the processed remaining signal to identify at least two occurrences of peaks of the second vibration in the processed remaining signal corresponding to at least two occurrences of peaks of the second vibration comprises analyzing the processed remaining signal to identify at least two adjacent occurrences of peaks of the second vibration in the processed remaining signal corresponding to at least two adjacent occurrences of peaks of the second vibration.

11. The method according to claim 10, wherein determining the second vibration rate from the at least two occurrences of peaks of the second vibration in the processed remaining signal comprises determining the second vibration rate from the at least two adjacent occurrences of peaks of the second vibration in the processed remaining signal.

12. The method according to claim 2, wherein determining an approximation of the first vibration from the signal representative of  $R(t)$  comprises:

analyzing the signal representative of  $R(t)$  to identify at least two occurrences of a known position on a cycle of the first vibration in the signal representative of  $R(t)$  corresponding to at least two occurrences of the known position separating the signal representative of  $R(t)$  into segments between

locations of known positions on the cycle of the first vibration in the signal representative of  $R(t)$  of the at least two occurrences of the known position on the cycle of the first vibration in the signal representative of  $R(t)$  and fitting a curve fit to the first vibration, wherein the curve fit is the approximation of the first vibration, wherein the at least two occurrences of the known position on the cycle of the first vibration in the signal representative of  $R(t)$  are at least two peaks of the first vibration in the signal representative of  $R(t)$ , wherein the at least two occurrences of the known position on the cycle of the second vibration in the processed remaining signal are at least two peaks of the second vibration in the processed remaining signal.

13. The method according to claim 1, wherein the first vibration amplitude is larger than the second vibration amplitude.

14. The method according to claim 1, wherein the target is selected from the group consisting of a human and an

animal, wherein the first vibration is a respiration of the target and the second vibration is a heartbeat of the target.

15-28. (canceled)

29. An apparatus, comprising:

a transmitter, wherein the transmitter is configured to transmit a transmit signal from a transmitting antenna at a target such that the transmit signal is reflected by the target to create a reflected signal, wherein the transmit signal and the reflected signal are electromagnetic signals having a wavelength,  $\lambda$ , where the transmit signal is represented as  $T(t)=\cos(\omega t+\phi(t))$  and the reflected signal is represented as  $R(t)=\cos(\omega(t-t_d)+\phi(t-t_d))$ , where  $t_d$  is a time period the transmit signal travels from the transmitting antenna to the target and the reflected signal travels from the target to the receiving antenna;

a receiver, wherein the receiver is configured to receive the reflected signal via a receiving antenna to create a receive signal, wherein the target is vibrating with a first vibration at a first vibration rate and a first vibration amplitude, wherein the target is vibrating with a second vibration at a second vibration rate and a second vibration amplitude, wherein a transmit distance between the transmitting antenna and the target and a receive distance between the target and the receiving antenna are such that  $\phi(t-t_d)\approx\phi(t)$  and the receive signal is approximated as  $R(t)=I(t)\cos(\omega t+\phi(t))+Q(t)\sin(\omega t+\phi(t))$ , where  $I(t)=\cos(4\pi d/\lambda)$ ,  $Q(t)=\sin(4\pi d/\lambda)$ ;

a processor, wherein the processor is configured to:

determine an approximation of the first vibration from a signal representative of  $R(t)$ ;

subtract the approximation of the first vibration from the signal representative of  $R(t)$  to produce a remaining signal;

process the remaining signal to produce a processed remaining signal; and

analyze the processed remaining signal to identify at least two occurrences of a known position on a cycle of the second vibration in the processed remaining signal corresponding to at least two occurrences of the known position on the cycle of the second vibration, wherein identification of occurrences of the known position on the cycle of the second vibration in the processed remaining signal is enhanced compared to identifying the remaining signal.

30. The apparatus according to claim 29, wherein the processor is configured to:

determine the second vibration rate from a corresponding at least two locations of the at least two occurrences of the known position on the cycle of the second vibration in the processed remaining signal.

31. The apparatus according to claim 29, wherein the signal representative of  $R(t)$  is  $B(t)$ , wherein  $B(t)$  is a baseband signal produced by combining  $I(t)$  and  $Q(t)$  such that  $B(t)=I(t)+jQ(t)=\exp(j4\pi d_0/\lambda)\exp(j(4\pi x_r(t)+4\pi x_r(t))/\lambda)$ , where  $d=t_r c/2$  and  $d=d_0+x_r(t)+x_r(t)$ .

32. The apparatus according to claim 29, wherein the processor is configured to determine an approximation of the first vibration from the signal representative of  $R(t)$  via:

analyzing the signal representative of  $R(t)$  to identify at least two occurrences of a known position on a cycle of the first vibration in the signal representative of  $R(t)$

corresponding to at least two occurrences of the known position on the cycle of the first vibration; and separating the signal representative of  $R(t)$  into segments between locations of known positions on the cycle of the first vibration in the signal representative of  $R(t)$  of the at least two occurrences of the known position on the cycle of the first vibration in the signal representative of  $R(t)$  and fitting a curve fit to the first vibration, wherein the curve fit is the approximation of the first vibration.

**33.** The apparatus according to claim **29**, wherein the at least two occurrences of the known position on the cycle of the second vibration in the processed remaining signal are at least two peaks of the second vibration in the processed remaining signal.

**34.** The apparatus according to claim **32**, wherein the at least two occurrences of the known position on the cycle of the first vibration in the signal representative of  $R(t)$  are at least two peaks of the first vibration in the signal representative of  $R(t)$ .

**35.** The apparatus according to claim **34**, wherein the at least two peaks of the first vibration are at least two adjacent peaks of the first vibration.

**36.** The apparatus according to claim **35**, wherein separating the signal representative of  $R(t)$  into segments between peaks of the at least two peaks of the first vibration in the signal representative of  $R(t)$  comprises separating the signal representative of  $R(t)$  into segments between adjacent

peaks of the at least two adjacent peaks of the first vibration in the signal representative of  $R(t)$ .

**37.** The apparatus according to claim **29**, wherein analyzing the processed remaining signal to identify at least two occurrences of the known position on the cycle of the second vibration in the processed remaining signal corresponding to at least two occurrences of the known position on the cycle of the second vibration comprises analyzing the processed remaining signal to identify at least two adjacent occurrences of the known position on the cycle of the second vibration in the processed remaining signal corresponding to at least two adjacent occurrences of the known position on the cycle of the second vibration.

**38.** The apparatus according to claim **30**, wherein the at least two occurrences of the known position on the cycle of the second vibration are at least two occurrences of peaks of the second vibration, wherein analyzing the processed remaining signal to identify at least two occurrences of peaks of the second vibration in the processed remaining signal corresponding to at least two occurrences of peaks of the second vibration comprises analyzing the processed remaining signal to identify at least two adjacent occurrences of peaks of the second vibration in the processed remaining signal corresponding to at least two adjacent occurrences of peaks of the second vibration.

**39-42.** (canceled)

\* \* \* \* \*

专利名称(译)	基于雷达信号的非接触式快速生命体征获取方法和装置		
公开(公告)号	<a href="#">US20180263502A1</a>	公开(公告)日	2018-09-20
申请号	US15/517214	申请日	2015-10-08
[标]申请(专利权)人(译)	佛罗里达大学研究基金会有限公司		
申请(专利权)人(译)	佛罗里达州研究基金会, INC大学.		
当前申请(专利权)人(译)	佛罗里达州研究基金会, INC大学.		
[标]发明人	LIN JENSHAN WEI CHANGYU		
发明人	LIN, JENSHAN WEI, CHANGYU		
IPC分类号	A61B5/0205 A61B5/05 A61B5/00 G01S13/88 G01S13/58		
CPC分类号	A61B5/0205 A61B5/05 A61B5/7239 A61B5/7214 G01S13/88 G01S13/583 A61B5/1102 A61B5/113 A61B2503/40 A61B5/0006 A61B5/0015 A61B5/7207 A61B5/7282 A61B8/02 A61B8/5223 G01S7/354 G01S7/415 G01S2007/358		
优先权	62/061320 2014-10-08 US		
外部链接	<a href="#">Espacenet</a> <a href="#">USPTO</a>		

摘要(译)

提供了用于非接触式生命体征获取的各种示例。可以使用雷达信号(例如,非接触式生命体征测量)提供关于目标的振动的信息。实例包括对人或其他动物的心率估计,心率变化,呼吸率和/或呼吸率变化。对于除了同时经历两次振动的动物或人类之外的目标,例如电动机,包含电动机的车辆或其他的目标,实施方式可以产生一个或两个振动速率和/或一个或两个振动速率的变化。物理对象。一些实施方式可以估计雷达基带输出信号中的呼吸运动。然后可以从时域中的雷达信号中减去估计的呼吸信号,并且可选地,可以使用数字信号处理技术进一步增强估计的呼吸信号,以产生心跳脉冲的估计。

