



US 20180140238A1

(19) **United States**

(12) **Patent Application Publication**  
**Johnson et al.**

(10) **Pub. No.: US 2018/0140238 A1**  
(43) **Pub. Date: May 24, 2018**

(54) **REGIONAL OXIMETRY SLEEVE FOR MOBILE DEVICE**

*A61B 5/00* (2006.01)  
*A61B 5/145* (2006.01)

(71) Applicant: **Nonin Medical, Inc.**, Plymouth, MN (US)

(52) **U.S. Cl.**  
CPC ..... *A61B 5/1455* (2013.01); *A61B 5/02055* (2013.01); *A61B 5/14535* (2013.01); *A61B 2560/045* (2013.01); *A61B 5/002* (2013.01)

(72) Inventors: **Timothy L. Johnson**, Plymouth, MN (US); **Bryant Austin Jones**, St. Louis Park, MN (US); **Christopher Holland**, Mayer, MN (US)

(57) **ABSTRACT**

(21) Appl. No.: **15/872,779**

(22) Filed: **Jan. 16, 2018**

**Related U.S. Application Data**

(62) Division of application No. 14/082,950, filed on Nov. 18, 2013, now Pat. No. 9,895,090.

**Publication Classification**

(51) **Int. Cl.**  
*A61B 5/1455* (2006.01)  
*A61B 5/0205* (2006.01)

A system includes a mobile computing device, a sleeve, a contact surface, a sensor module, and a telemetry module. The mobile computing device has a first processor within a housing. The sleeve has an internal surface configured to fit the housing. The contact surface is disposed on an external surface of the sleeve. The sensor module is coupled to the contact surface and is configured to generate an electrical signal corresponding to a measured physiological parameter associated with tissue at the contact surface. The telemetry module is coupled to the sensor module and is configured to communicate data corresponding to the electrical signal to the mobile computing device.

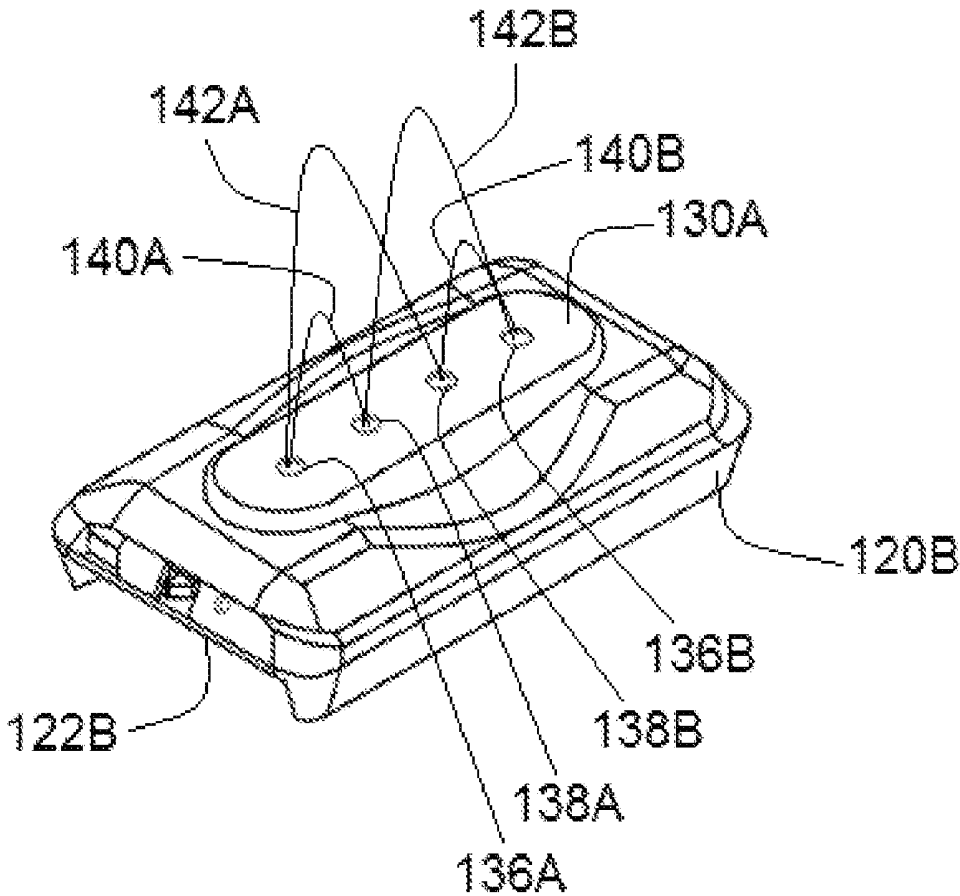

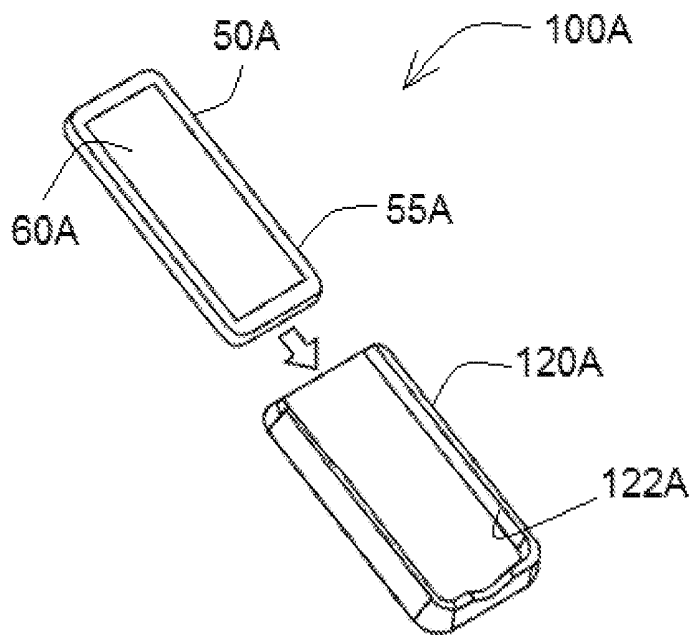

FIG. 1A

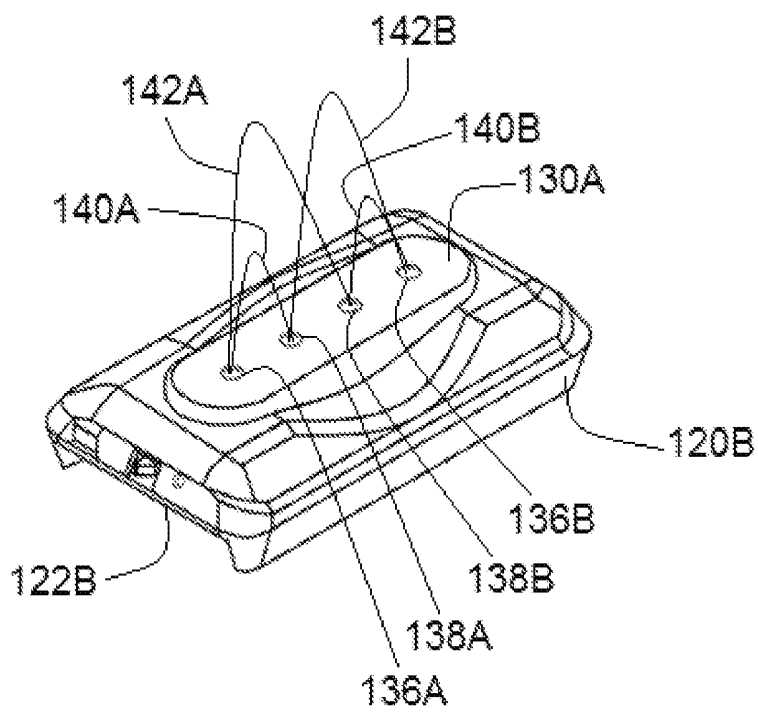

FIG. 1B

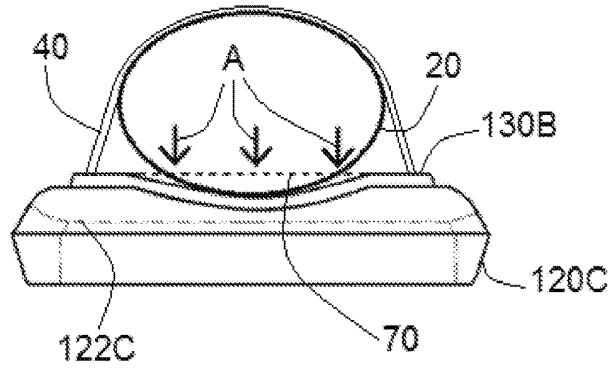

FIG. 2

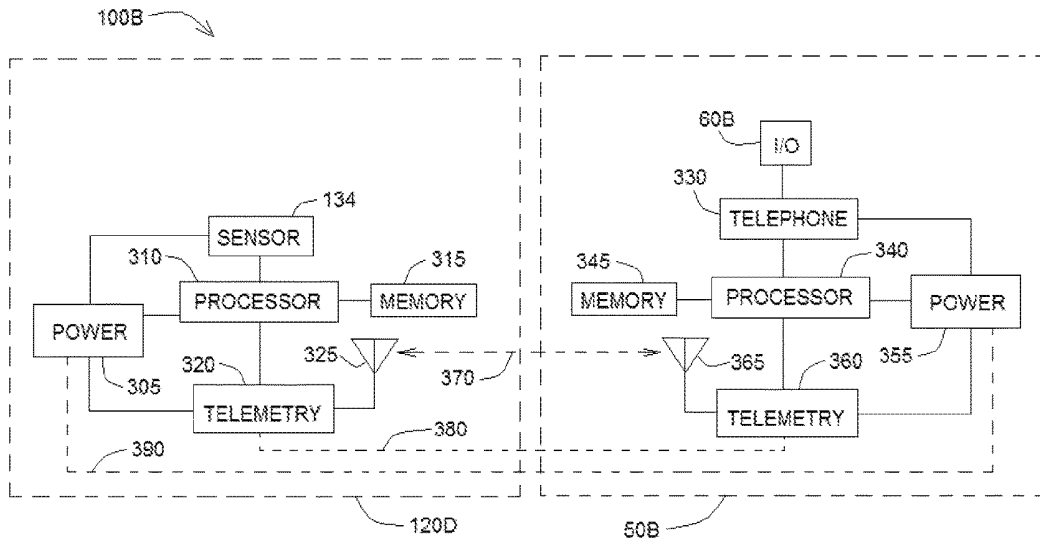

FIG. 3

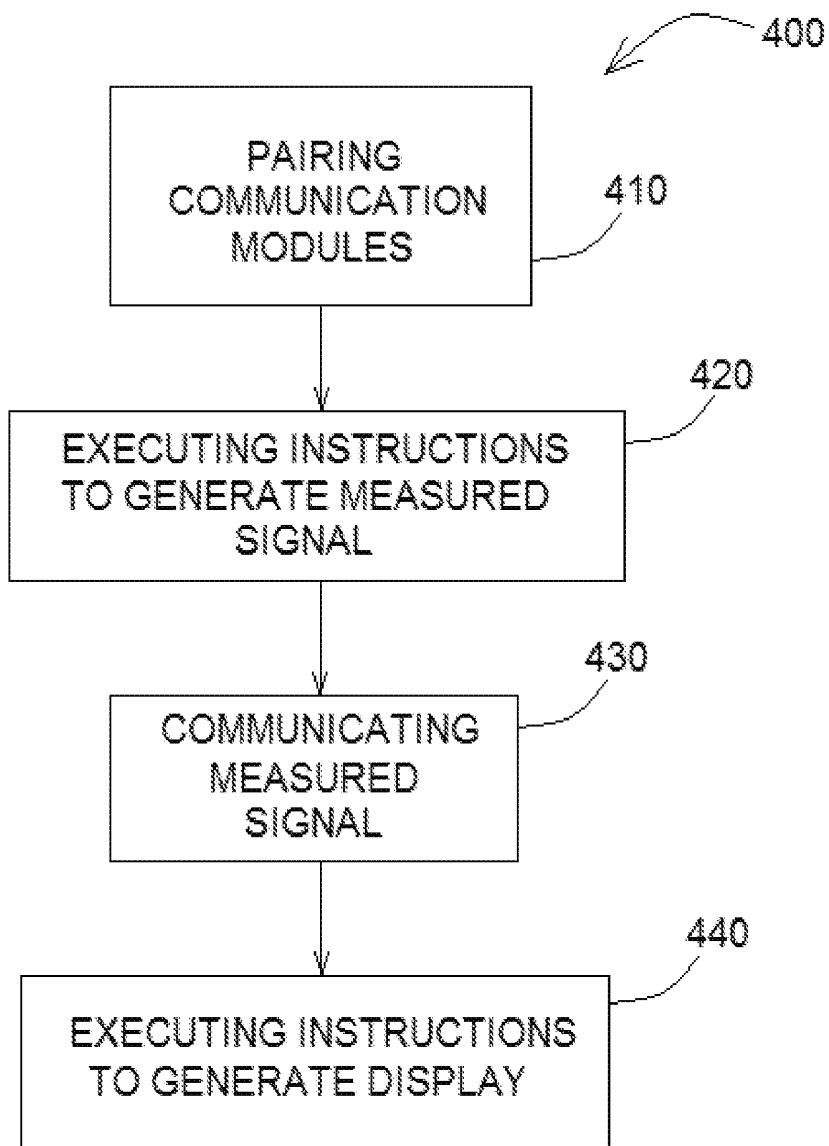

FIG. 4

## REGIONAL OXIMETRY SLEEVE FOR MOBILE DEVICE

### CLAIM OF PRIORITY

[0001] This application is a divisional of and claims the benefit of priority under 35 U.S.C. § 120 to U.S. patent application Ser. No. 14/082,950, filed on Nov. 18, 2013, which is hereby incorporated by reference herein in its entirety.

### BACKGROUND

[0002] A measure of regional oximetry can provide an indication as to tissue health. Existing technology for measuring regional oximetry is inadequate. One example includes an optical sensor coupled by a wire to a separate processing module. The sensor may be secured to the patient by an adhesive or by a strap encircling the patient and is tethered by wire to the processing module.

[0003] This arrangement of a sensor and a processor module with a connecting wire is unsatisfactory for certain applications. For example, in an emergency situation or a battlefield environment, the separate nature of the modules and the connecting wire can be inconvenient and may be prone to failure.

### OVERVIEW

[0004] The present inventors have recognized, among other things, that a problem to be solved can include providing a system for measuring regional oximetry based on a rapidly established temporary coupling to the tissue and using a mobile computing device. The present subject matter can help provide a solution to this problem, such as by a system including a sensor module that can be coupled to a mobile device and manually positioned at a tissue site. The mobile device can display results and can communicate the data to a remote device using wireless communication.

[0005] This overview is intended to provide an overview of subject matter of the present patent application. It is not intended to provide an exclusive or exhaustive explanation of the invention. The detailed description is included to provide further information about the present patent application.

### BRIEF DESCRIPTION OF THE DRAWINGS

[0006] In the drawings, which are not necessarily drawn to scale, like numerals may describe similar components in different views. Like numerals having different letter suffixes may represent different instances of similar components. The drawings illustrate generally, by way of example, but not by way of limitation, various embodiments discussed in the present document.

[0007] FIG. 1A illustrates a view of a sleeve and mobile computing device, according to one example.

[0008] FIG. 1B illustrates a view of a sleeve, according to one example.

[0009] FIG. 2 illustrates a view of a sleeve with tissue, according to one example.

[0010] FIG. 3 illustrates a block diagram of a system, according to one example.

[0011] FIG. 4 illustrates a flow chart of a system, according to one example.

### DETAILED DESCRIPTION

[0012] FIG. 1A illustrates a view of system 100A, including sleeve 120A and mobile computing device 50A, according to one example. Mobile computing device 50A includes user interface 60A, here shown as a touch-screen configured for displaying data and for receiving user input. Mobile computing device 50A includes housing 55A having an outer dimension that can be characterized as a length, a width, or a thickness. Mobile computing device 50A can include a cellular telephone (such as a smart-phone), a mini computer, or a tablet computer.

[0013] Sleeve 120A has inner surface 122A configured to receive housing 55A. Sleeve 120A can include a rubber molded component or a plastic component having an inner surface configured to securely couple with mobile computing device 50A and to provide physical protection to mobile computing device 50A.

[0014] FIG. 1B illustrates a view of sleeve 120B, according to one example. Sleeve 120B includes inner surface 122B configured to mate with an external dimension of a mobile computing device. Sleeve 120B includes contact surface 130A. Contact surface 130A has a sensor module including emitter 138A and emitter 138B. Emitter 138A emits light that is received by detector 136A along short pathway 140A and light that is received by detector 136B along long pathway 142B. Emitter 138B emits light that is received by detector 136B along short pathway 140B and light that is received by detector 136A along long pathway 142A. Light received by detector 136A and detector 136B, using the combination of long pathway 142A, long pathway 142B, short pathway 140A, and short pathway 140B can be processed to generate a measure of regional oximetry (also called tissue oximetry). In one example, the calculation entails addition and subtraction of attenuations as detected by detector 136A and detector 136B. Detector 136A and detector 136B can include an optical transducer that provides an electrical signal corresponding to detected light.

[0015] The arrangement of optical elements (such as emitter 138A, emitter 138B, detector 136A, and detector 136B) and the number of optical elements (or transducers) can be configured for a particular purpose. In one example, contact surface 130A is arranged such that emitter 138A and emitter 138B are at opposing ends and detector 136A and detector 136B are located there between.

[0016] FIG. 2 illustrates a view of sleeve 120C with tissue 20, according to one example. Sleeve 120C includes an inner surface 122C configured to receive a mobile computing device. Sleeve 120C includes contact surface 130B. Contact surface 130B includes a sensor module configured to generate data as to tissue 20 in contact with contact surface 130B. In the example illustrated, tissue 20 is urged against contact surface 130B with sufficient force, as shown at arrows A, to deflect a compliant surface of contact surface 130B. As shown, contact surface 130B has a profile as indicated at 70 at a time before tissue 20 is urged into contact surface 130B. Strap 40 is affixed to sleeve 120C and encircles a portion of tissue 20, here shown as a section view of a limb (such as an arm or a leg). Strap 40, in one example includes a band or strap to retain tissue 20 and contact surface 130B in close proximity. In one example, contact surface 130B has a pre-formed contour that conforms to tissue 20.

[0017] FIG. 3 illustrates a block diagram of system 100B, according to one example. System 100B includes sleeve

120D and mobile computing device 50B. Sleeve 120D includes sensor module 134, processor 310, memory 315, telemetry module 320, and power supply 305.

[0018] Power supply 305 can include a battery and circuitry for regulating power or for charging a battery. In one example, power 305 derives electrical energy from a wired coupling with power supply 355 of mobile computing device 50B, as shown by link 390. Power supply 305 is coupled to sensor module 134, processor 310, and telemetry module 320.

[0019] Sensor module 134 can include a one or more optical detectors (such as detector 136A or detector 136B), one or more optical emitters (such as emitter 138A and emitter 138B), a temperature sensor, a pressure sensor, or an accelerometer. In various examples, a sensor can be referred to as a transducer.

[0020] Processor 310, along with measured data from sensor module 134, can provide a variety of blood and tissue measurements. For example, a suitable algorithm and a sensor can be configured to provide data as to the following parameters or conditions:

- [0021] Regional saturation (rSO<sub>2</sub>)
- [0022] Hemoglobin (Hb) concentration in tissue
- [0023] Tissue temperature
- [0024] SpO<sub>2</sub>
- [0025] Total hemoglobin (tHb)
- [0026] Hematocrit
- [0027] Anemia
- [0028] CO<sub>2</sub>
- [0029] COHb
- [0030] MetHb
- [0031] pH
- [0032] Respiration
- [0033] Perfusion
- [0034] Apnea
- [0035] Pulse wave velocity
- [0036] Blood pressure
- [0037] Interstitial pressure
- [0038] Arterial stiffness
- [0039] Intracranial Pressure
- [0040] Intrauterine pressure/contractions
- [0041] Glucose
- [0042] Cardiac output
- [0043] Bilirubin
- [0044] Hydration
- [0045] Hematoma
- [0046] Vascular compliance
- [0047] Tissue viability
- [0048] Malaria
- [0049] Blood cancer
- [0050] Thrombocytopenia (low platelet count)
- [0051] Sepsis
- [0052] Thrombosis
- [0053] Compartment syndrome

[0054] In addition, a suitable algorithm and sensor module can provide data as to a material property of an object or as to a surface. This can include processing based on data corresponding to an optical measurement, a mechanical measurement, an acoustic measurement, or an electrical measurement. For example, data can correspond to an event counter, an event marker (time mark), a density measurement, a conductivity measurement, a concentration measurement, a color measurement, or a light level measurement.

[0055] Processor 310 can include a digital processor or an analog processor circuit. In one example, processor 310 includes a microprocessor. In the example shown, processor 310 is coupled to memory 315 and processor 310 is configured to execute instructions to implement an algorithm as described elsewhere in this document. In one example, memory 315 is configured to store data generated by sensor module 134 or configured to store calibration information for sensor module 134.

[0056] Processor 310 is coupled to telemetry module 320. In one example, telemetry module 320 includes a wired connection with a corresponding telemetry module 360 of mobile computing device 50B, as shown at link 380. In one example, telemetry module 320 communicates with telemetry module 360 by a wireless channel, as depicted by antenna 325 and antenna 365, shown at link 370. In one example, link 370 includes a radio frequency communication channel, one example of which is known commonly as Bluetooth. In other examples, link 370 includes an infrared communication channel, a near-field inductive coupling, or an ultrasonic (or acoustic) coupling.

[0057] Mobile computing device 50B includes I/O module 60B coupled to telephone module 330. I/O module 60B can include a touch-sensitive screen configured to receive user-entered data or keystrokes and configured to display visual data. Telephone module 330 can include a cellular telephone module, a text message module, or other wireless communication module. Telephone module 330 can allow data exchange with a cloud-based server or storage facility. Telephone module 330 is coupled to processor 340. Processor 340 is coupled to memory 345 and coupled to telemetry module 360. Mobile computing device 50B includes power 355 coupled to telephone module 330, processor 340, and telemetry module 360.

[0058] FIG. 4 illustrates flow chart 400 implemented by a system, according to one example. Flow chart 400 includes, at 410, pairing communication modules. In one example, this entails establishing a wireless link between telemetry module 320 (and using antenna 325) and telemetry module 360 (and using antenna 365) in a process known as pairing. Pairing can include exchanging access credentials and coordinating handshaking protocols. Some communication protocols, such as Bluetooth, are paired by executing a predetermined algorithm.

[0059] At 420, method 400 includes executing instructions to generate a measured signal using sensor module 134. This can include executing instructions (stored in memory 315) using processor 310 to implement an algorithm. The algorithm can entail operating an emitter (such as emitter 138A or emitter 138B) according to a particular protocol and receiving an output signal from a detector (such as detector 136A or detector 136B). In one example, this can include receiving a temperature signal from a temperature transducer.

[0060] At 430, method 400 includes communicating the measured signal to the mobile computing device. Communicating can include sending and receiving a wireless signal (using wireless telemetry modules) or can include communicating using a wired connection between the sleeve and the mobile computing device.

[0061] At 440, method 400 includes executing instructions using processor 340 to generate a visible display of data. The data can be displayed on user interface 60A or on I/O module 60B.

## Various Notes &amp; Examples

**[0062]** Example 1 can include a system having a mobile computing device, a sleeve, a contact surface, a sensor module, and a telemetry module. The mobile computing device can include a first processor within a housing. The sleeve can include an internal surface configured to fit the housing. The contact surface can include an external surface of the sleeve. The sensor module is coupled to the contact surface and can be configured to generate an electrical signal corresponding to a measured physiological parameter associated with tissue at the contact surface. The telemetry module can be coupled to the sensor module and configured to communicate data corresponding to the electrical signal to the mobile computing device.

**[0063]** Example 2 can include, or can optionally be combined with the subject matter of Example 1 to optionally include wherein the mobile computing device includes a smart telephone.

**[0064]** Example 3 can include, or can optionally be combined with the subject matter of Example 1 to optionally include wherein the contact surface includes a compliant member, the compliant member configured to conform to a tissue contour.

**[0065]** Example 4 can include, or can optionally be combined with the subject matter of Example 1 to optionally include wherein the contact surface has a curved contour.

**[0066]** Example 5 can include, or can optionally be combined with the subject matter of Example 1 to optionally include wherein the contact surface includes a non-stick surface.

**[0067]** Example 6 can include, or can optionally be combined with the subject matter of Example 1 to optionally include wherein the electrical signal corresponds to regional oximetry.

**[0068]** Example 7 can include, or can optionally be combined with the subject matter of Example 1 to optionally include wherein the sensor module includes at least two optical detectors and wherein the electrical signal is determined by a combination of the at least two optical detectors.

**[0069]** Example 8 can include, or can optionally be combined with the subject matter of Example 1 to optionally include wherein the sensor module is coupled to a battery.

**[0070]** Example 9 can include, or can optionally be combined with the subject matter of Example 1 to optionally include a second processor coupled to the sensor module, the second processor configured to generate the data.

**[0071]** Example 10 can include, or can optionally be combined with the subject matter of Example 1 to optionally include wherein the telemetry module includes a wireless transceiver.

**[0072]** Example 11 can include, or can optionally be combined with the subject matter of Example 1 to optionally include wherein the mobile computing device is configured to execute instructions to communicate with a remote device.

**[0073]** Example 12 can include, or can optionally be combined with the subject matter of Example 1 to optionally include wherein the mobile computing device is configured to execute instructions to communicate with a remote device in near real-time.

**[0074]** Example 13 can include, or can optionally be combined with the subject matter of Example 1 to optionally include wherein the housing includes a retention strap.

**[0075]** Example 14 can include a device having a sleeve, a contact surface, a sensor module, and a telemetry module. The sleeve can have an internal surface configured to fit an external dimension of a mobile computing device. The contact surface is on an external surface of the sleeve. The sensor module is coupled to the contact surface and configured to generate an electrical signal corresponding to a measured physiological parameter associated with tissue at the contact surface. The telemetry module is coupled to the sensor module and configured to communicate data corresponding to the electrical signal to the mobile computing device.

**[0076]** Example 15 can include, or can optionally be combined with the subject matter of Example 14 to optionally include wherein the sleeve includes a rubber housing.

**[0077]** Example 16 can include, or can optionally be combined with the subject matter of Example 14 to optionally include wherein the electrical signal corresponds to regional oximetry.

**[0078]** Example 17 can include, or can optionally be combined with the subject matter of Example 14 to optionally include wherein the telemetry module includes a radio frequency transceiver.

**[0079]** Example 18 can include, or can optionally be combined with the subject matter of Example 14 to optionally include a battery coupled to at least one of the sensor module and the telemetry module.

**[0080]** Example 19 can include, or can optionally be combined with the subject matter of Example 14 to optionally include wherein the sensor module includes at least two optical detectors.

**[0081]** Example 20 can include a method including pairing a first communication module of a mobile computing device with a second communication module of a sleeve. The mobile computing device is configured to fit an internal surface of the sleeve. The sleeve has a sleeve processor coupled to a sleeve memory and the sleeve has a contact surface. The method includes executing instructions using the sleeve processor. The instructions are stored on the sleeve memory. The instructions are configured to generate a measured signal using an optical sensor coupled to the contact surface. The measured signal corresponds to a tissue at the contact surface. The method includes communicating the measured signal from the sleeve to the mobile computing device using the first communication module and using the second communication module. The method includes executing instructions using the device processor to generate display data for a display of the mobile computing device.

**[0082]** Example 21 can include, or can optionally be combined with the subject matter of Example 20 to optionally include wherein executing the instructions using the sleeve processor includes calculating a temperature using a temperature transducer.

**[0083]** Example 22 can include, or can optionally be combined with the subject matter of Example 20 to optionally include wherein executing the instructions using the sleeve processor includes emitting light from the optical sensor.

**[0084]** Example 23 can include, or can optionally be combined with the subject matter of Example 20 to optionally include wherein executing the instructions using the sleeve processor includes calculating regional oximetry.

**[0085]** Example 24 can include, or can optionally be combined with the subject matter of Example 20 to option-

ally include displaying regional oximetry data based on the display data using the display.

**[0086]** Each of these non-limiting examples can stand on its own, or can be combined in various permutations or combinations with one or more of the other examples.

**[0087]** The above detailed description includes references to the accompanying drawings, which form a part of the detailed description. The drawings show, by way of illustration, specific embodiments in which the invention can be practiced. These embodiments are also referred to herein as “examples.” Such examples can include elements in addition to those shown or described. However, the present inventors also contemplate examples in which only those elements shown or described are provided. Moreover, the present inventors also contemplate examples using any combination or permutation of those elements shown or described (or one or more aspects thereof), either with respect to a particular example (or one or more aspects thereof), or with respect to other examples (or one or more aspects thereof) shown or described herein.

**[0088]** In the event of inconsistent usages between this document and any documents so incorporated by reference, the usage in this document controls.

**[0089]** In this document, the terms “a” or “an” are used, as is common in patent documents, to include one or more than one, independent of any other instances or usages of “at least one” or “one or more.” In this document, the term “or” is used to refer to a nonexclusive or, such that “A or B” includes “A but not B,” “B but not A,” and “A and B,” unless otherwise indicated. In this document, the terms “including” and “in which” are used as the plain-English equivalents of the respective terms “comprising” and “wherein.” Also, in the following claims, the terms “including” and “comprising” are open-ended, that is, a system, device, article, composition, formulation, or process that includes elements in addition to those listed after such a term in a claim are still deemed to fall within the scope of that claim. Moreover, in the following claims, the terms “first,” “second,” and “third,” etc. are used merely as labels, and are not intended to impose numerical requirements on their objects.

**[0090]** Method examples described herein can be machine or computer-implemented at least in part. Some examples can include a computer-readable medium or machine-readable medium encoded with instructions operable to configure an electronic device to perform methods as described in the above examples. An implementation of such methods can include code, such as microcode, assembly language code, a higher-level language code, or the like. Such code can include computer readable instructions for performing various methods. The code may form portions of computer program products. Further, in an example, the code can be tangibly stored on one or more volatile, non-transitory, or non-volatile tangible computer-readable media, such as during execution or at other times. Examples of these tangible computer-readable media can include, but are not limited to, hard disks, removable magnetic disks, removable optical disks (e.g., compact disks and digital video disks), magnetic cassettes, memory cards or sticks, random access memories (RAMS), read only memories (ROMs), and the like.

**[0091]** The above description is intended to be illustrative, and not restrictive. For example, the above-described examples (or one or more aspects thereof) may be used in combination with each other. Other embodiments can be used, such as by one of ordinary skill in the art upon reviewing the above description. The Abstract is provided to comply with 37 CFR. § 1.72(b), to allow the reader to quickly ascertain the nature of the technical disclosure. It is submitted with the understanding that it will not be used to interpret or limit the scope or meaning of the claims. Also, in the above Detailed Description, various features may be grouped together to streamline the disclosure. This should not be interpreted as intending that an unclaimed disclosed feature is essential to any claim. Rather, inventive subject matter may lie in less than all features of a particular disclosed embodiment. Thus, the following claims are hereby incorporated into the Detailed Description as examples or embodiments, with each claim standing on its own as a separate embodiment, and it is contemplated that such embodiments can be combined with each other in various combinations or permutations. The scope of the invention should be determined with reference to the appended claims, along with the full scope of equivalents to which such claims are entitled.

The claimed invention is:

**1.** A method comprising:

pairing a first communication module of a mobile computing device with a second communication module of a sleeve, the mobile computing device configured to fit an internal surface of the sleeve, the sleeve having a sleeve processor coupled to a sleeve memory and the sleeve having a contact surface;

executing instructions using the sleeve processor, the instructions stored on the sleeve memory, the instructions configured to generate a measured signal using an optical sensor coupled to the contact surface, the measured signal corresponding to a tissue at the contact surface;

communicating the measured signal from the sleeve to the mobile computing device using the first communication module and using the second communication module; and

executing instructions using the device processor to generate display data for a display of the mobile computing device.

**2.** The method of claim 1 wherein executing the instructions using the sleeve processor includes calculating a temperature using a temperature transducer.

**3.** The method of claim 1 wherein executing the instructions using the sleeve processor includes emitting light from the optical sensor.

**4.** The method of claim 1 wherein executing instructions using the sleeve processor includes calculating regional oximetry.

**5.** The method of claim 1 further including displaying regional oximetry data based on the display data using the display.

\* \* \* \* \*

专利名称(译)	用于移动设备的区域血氧测定套管		
公开(公告)号	<a href="#">US20180140238A1</a>	公开(公告)日	2018-05-24
申请号	US15/872779	申请日	2018-01-16
[标]申请(专利权)人(译)	NONIN医疗		
申请(专利权)人(译)	NONIN MEDICAL , INC.		
当前申请(专利权)人(译)	NONIN MEDICAL , INC.		
[标]发明人	JOHNSON TIMOTHY L JONES BRYANT AUSTIN HOLLAND CHRISTOPHER		
发明人	JOHNSON, TIMOTHY L. JONES, BRYANT AUSTIN HOLLAND, CHRISTOPHER		
IPC分类号	A61B5/1455 A61B5/0205 A61B5/00 A61B5/145		
CPC分类号	A61B2560/045 A61B5/14535 A61B5/14552 A61B5/002 A61B5/02055		
其他公开文献	US10709368		
外部链接	<a href="#">Espacenet</a> <a href="#">USPTO</a>		

摘要(译)

一种系统包括移动计算设备，套管，接触表面，传感器模块和遥测模块。该移动计算设备在外壳内具有第一处理器。套筒具有构造成适合外壳的内表面。接触表面设置在套筒的外表面上。传感器模块联接到接触表面并且被配置成生成与在接触表面处与组织相关联的测量的生理参数相对应的电信号。遥测模块耦合到传感器模块并且被配置为将对应于电信号的数据传送到移动计算设备。

