



US 20180042554A1

(19) **United States**

(12) **Patent Application Publication**  
**Wagner et al.**

(10) **Pub. No.: US 2018/0042554 A1**

(43) **Pub. Date: Feb. 15, 2018**

(54) **OPTICAL MONITORING APPARATUS AND METHODS**

(60) Provisional application No. 62/033,922, filed on Aug. 6, 2014.

(71) Applicant: **Valencell, Inc.**, Raleigh, NC (US)

**Publication Classification**

(72) Inventors: **Wolfgang Wagner**, Chapel Hill, NC (US); **Shawn Stephenson**, Raleigh, NC (US); **Steven Matthew Just**, Cary, NC (US); **Michael Edward Aumer**, Raleigh, NC (US); **Jesse Berkley Tucker**, Youngsville, NC (US); **Lawrence Christopher Eschbach**, Louisburg, NC (US); **Steven Francis LeBoeuf**, Raleigh, NC (US)

(51) **Int. Cl.**  
*A61B 5/00* (2006.01)  
(52) **U.S. Cl.**  
CPC ..... *A61B 5/6815* (2013.01); *A61B 5/6898* (2013.01); *A61B 2562/0233* (2013.01)

(21) Appl. No.: **15/794,728**

(57) **ABSTRACT**

(22) Filed: **Oct. 26, 2017**

An apparatus includes a digital camera configured to capture a plurality of images of a region of a body of a subject, a photoplethysmography (PPG) sensor configured to sense blood flow information from the subject, and a processor in communication with the digital camera and the PPG sensor. The processor is configured to analyze a blood flow information signal from the PPG sensor and determine a heart rate frequency and/or a breathing rate frequency of the subject. The processor is also configured to analyze the plurality of images and determine whether or not a portion of the region of the body is modulating at a frequency that is similar to the heart rate frequency and/or the breathing rate frequency of the subject.

**Related U.S. Application Data**

(63) Continuation of application No. 15/324,139, filed on Jan. 5, 2017, filed as application No. PCT/US2015/041562 on Jul. 22, 2015.

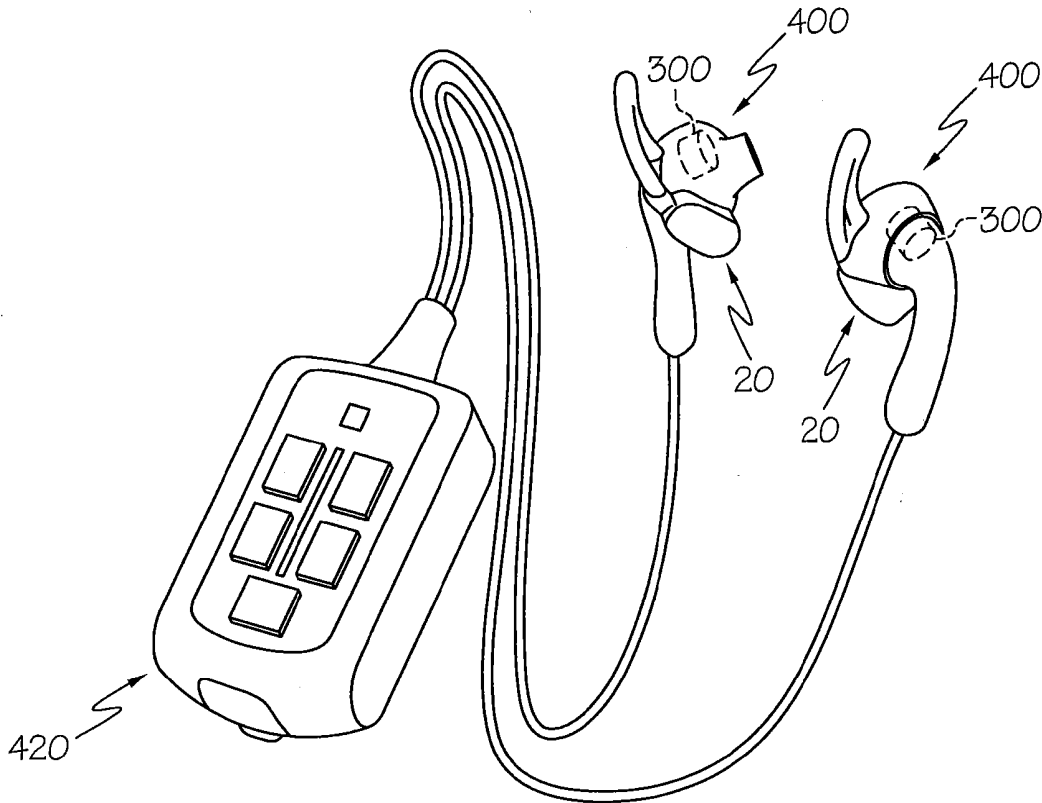

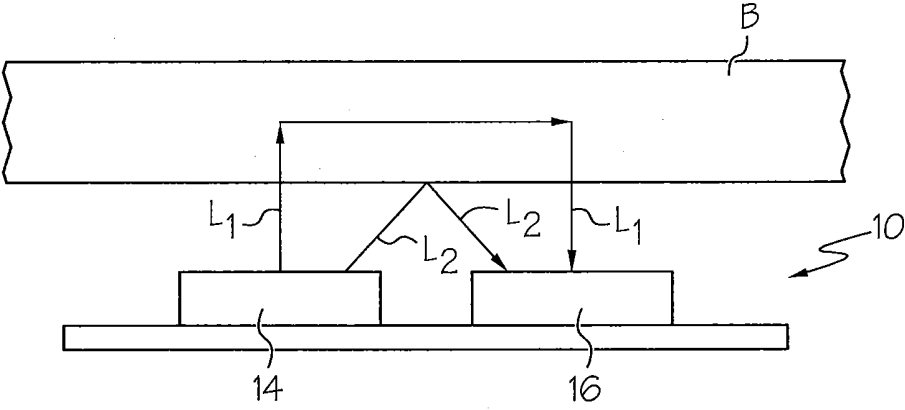

FIG. 1

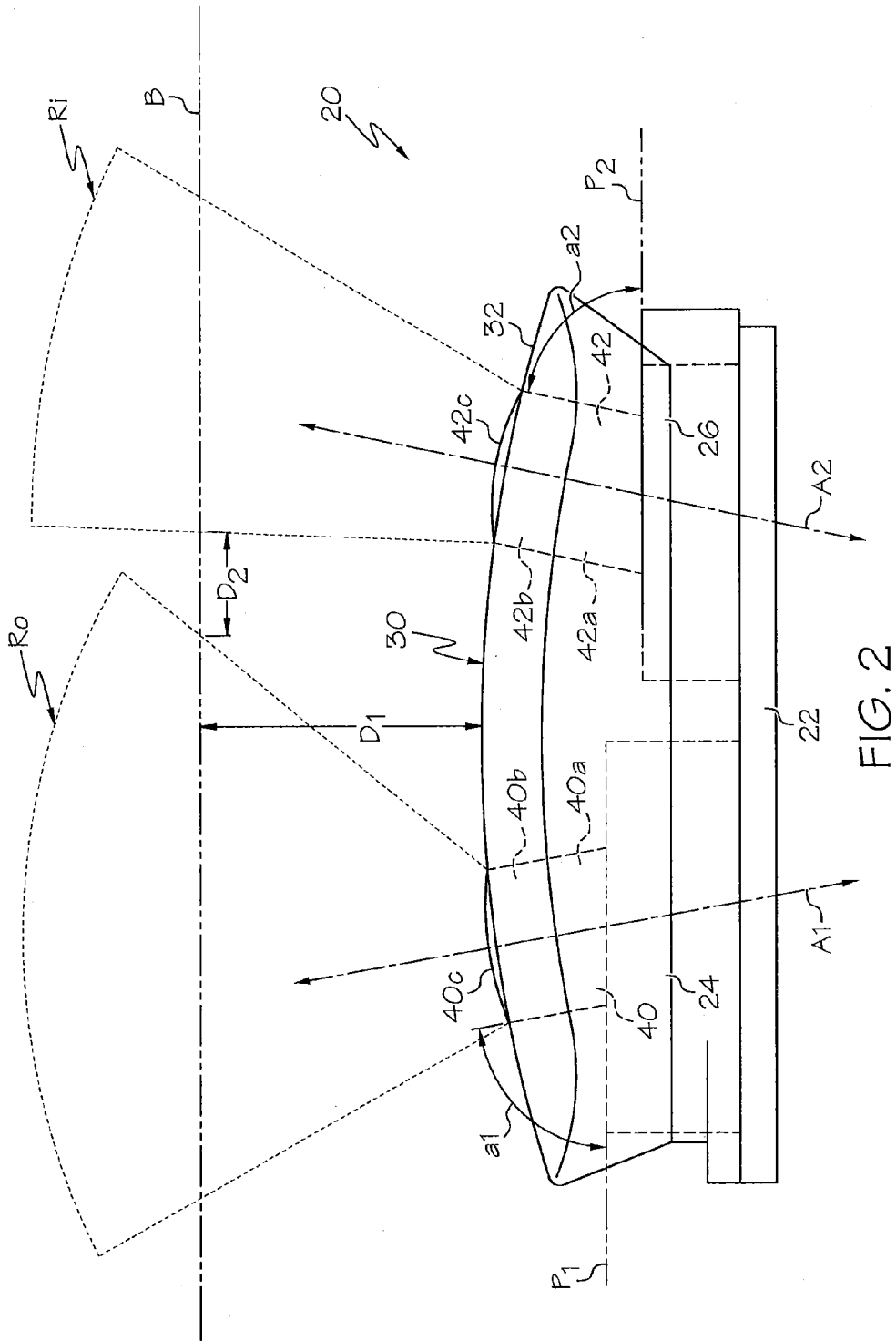

FIG. 2

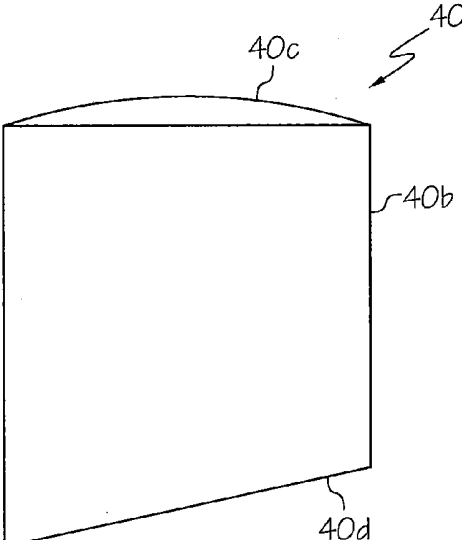

FIG. 3A

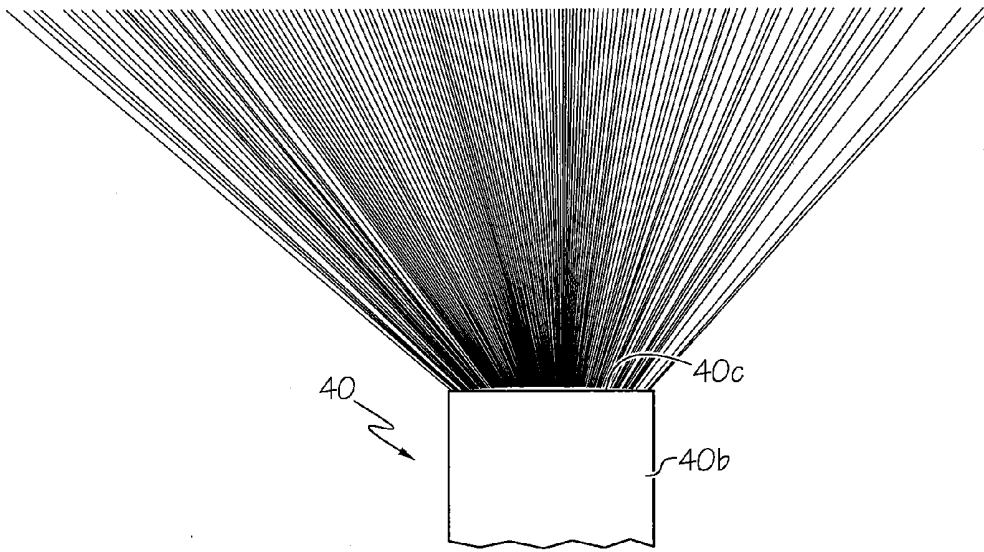

FIG. 3B

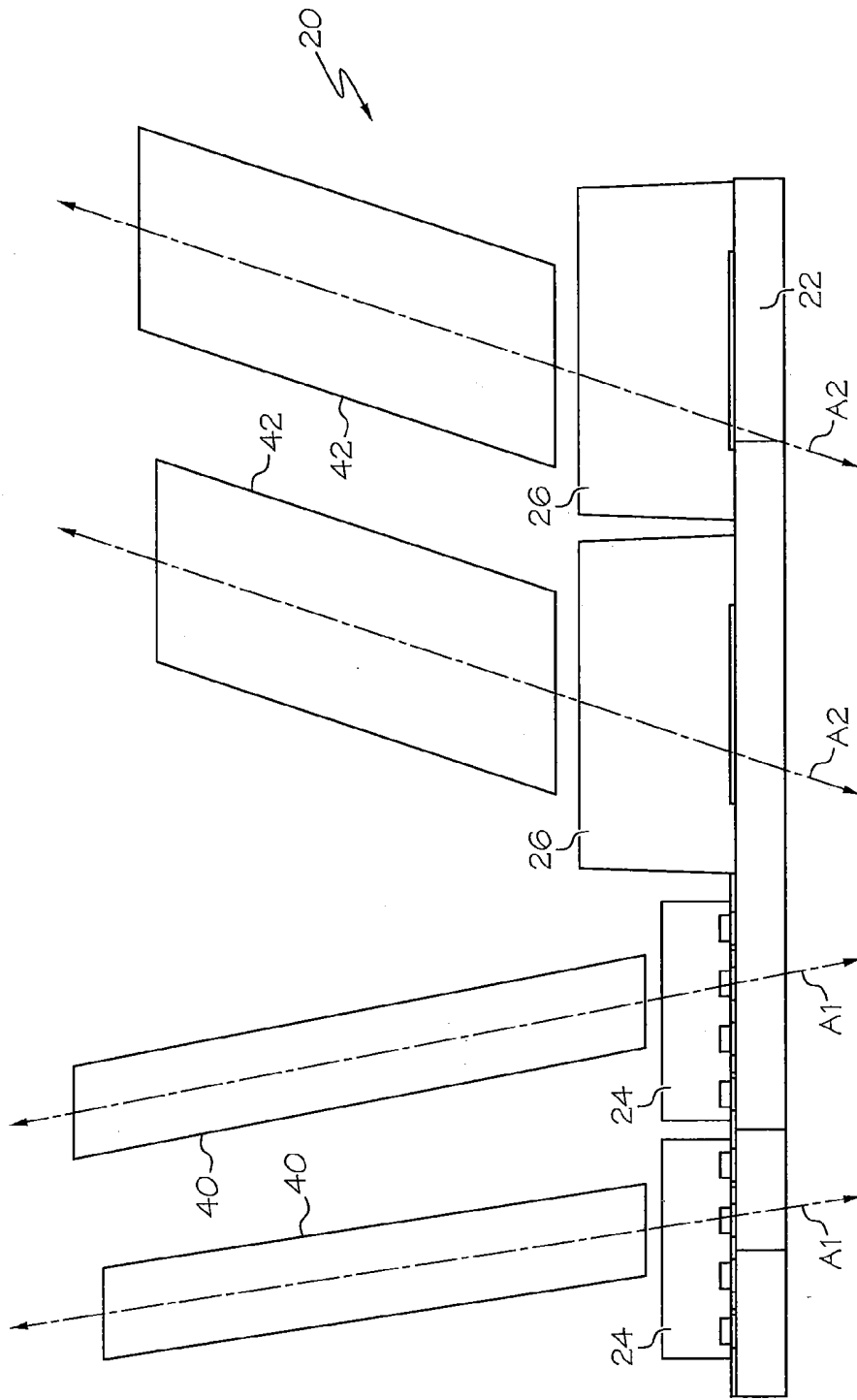

FIG. 4

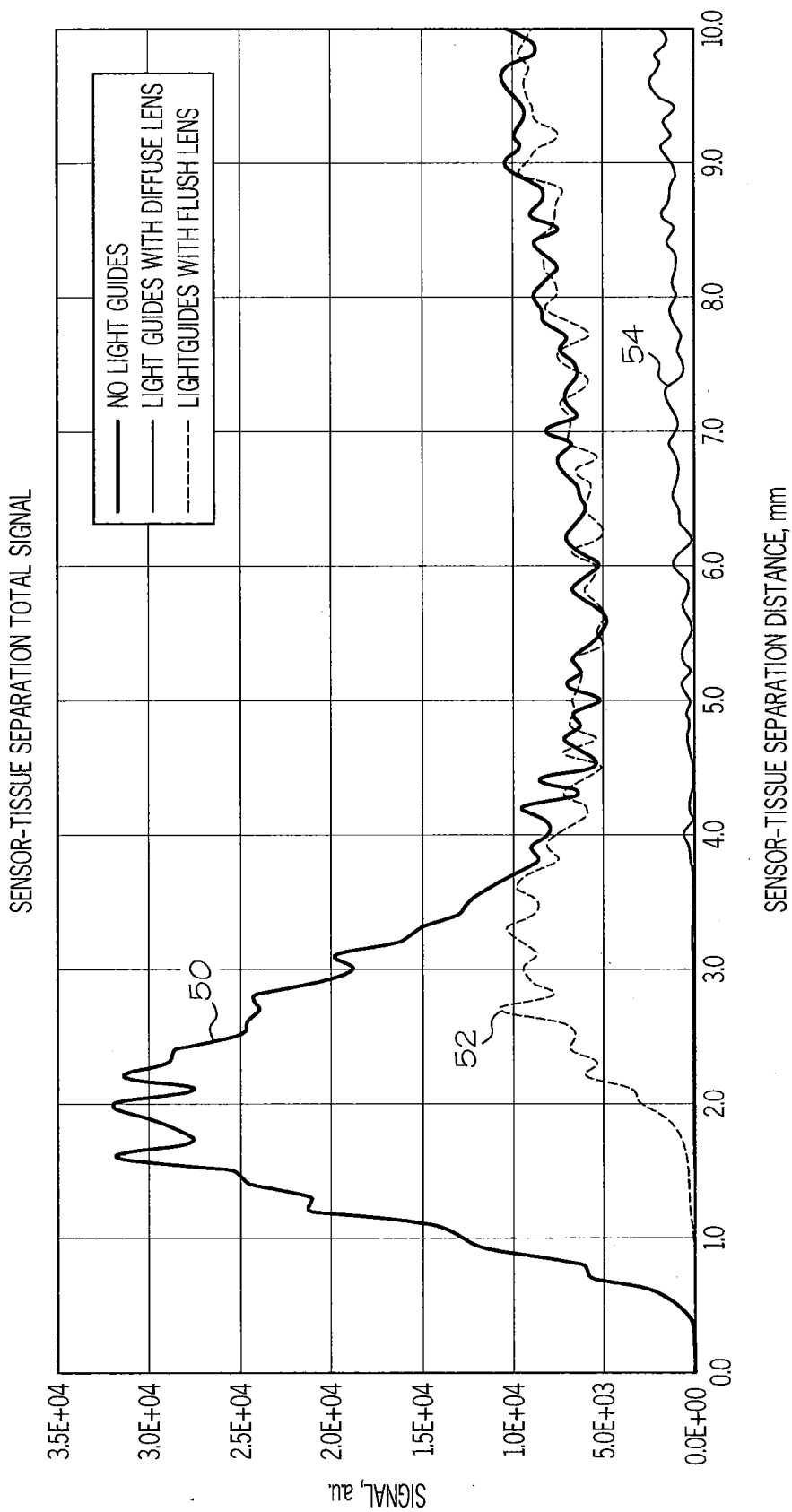

FIG. 5



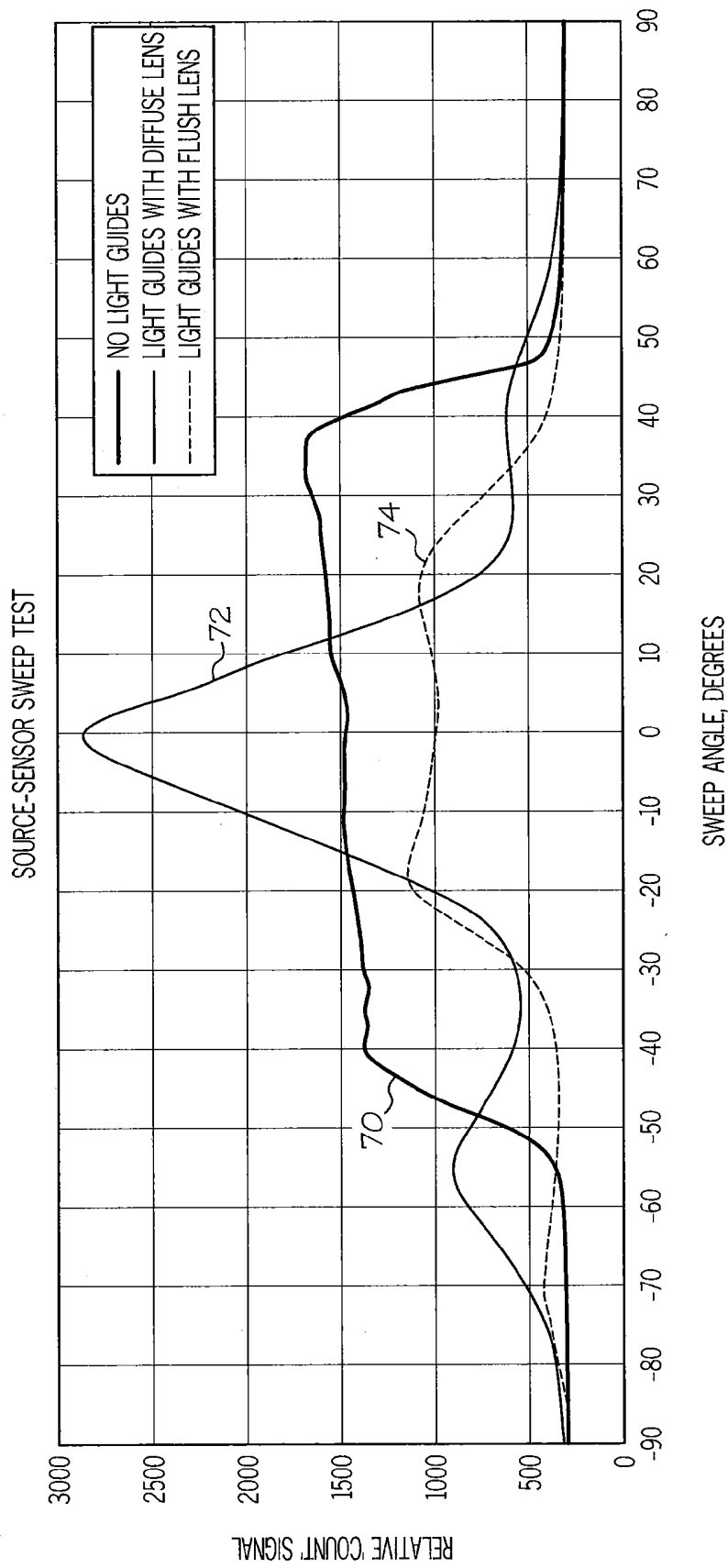

FIG. 7

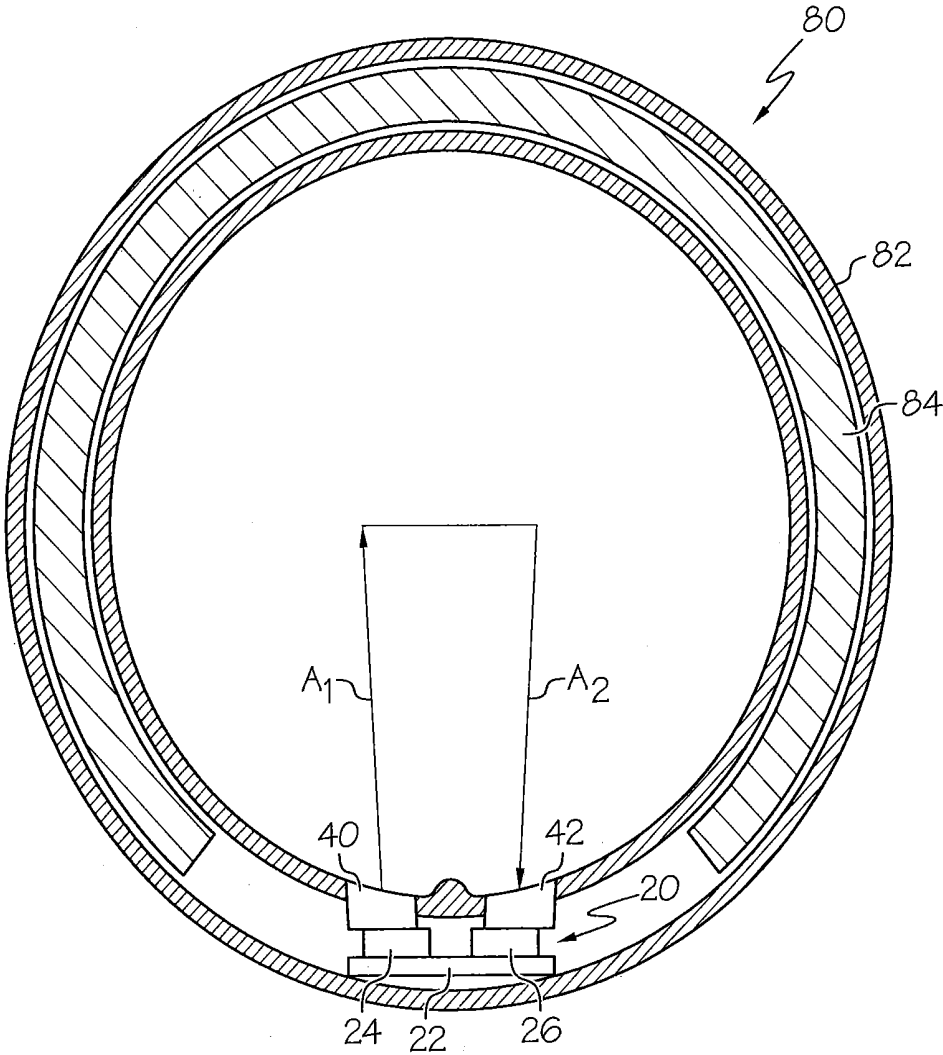

FIG. 8

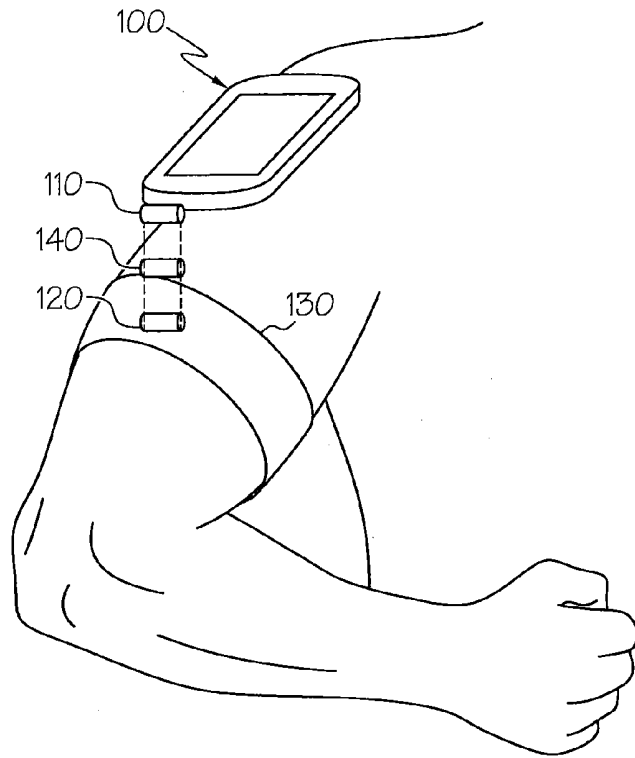

FIG. 9A

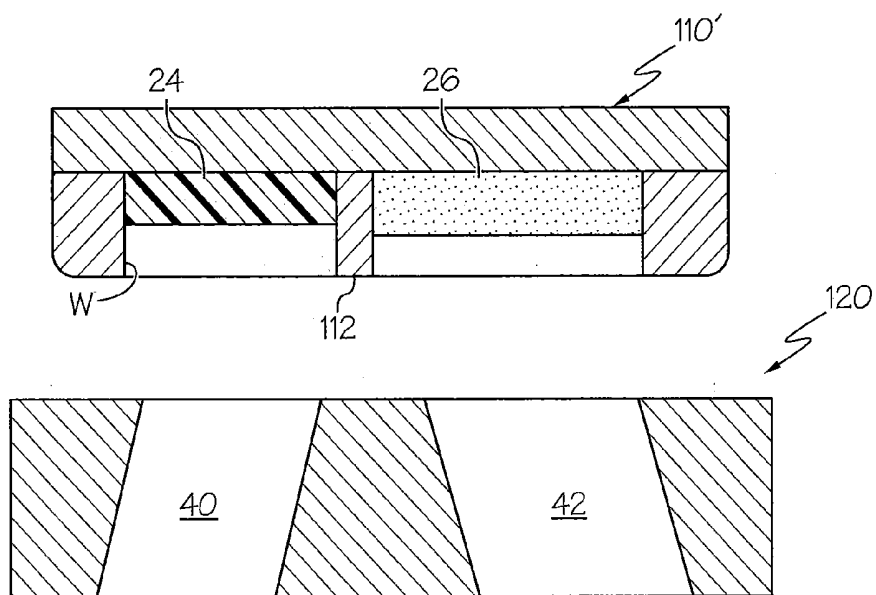

FIG. 9B

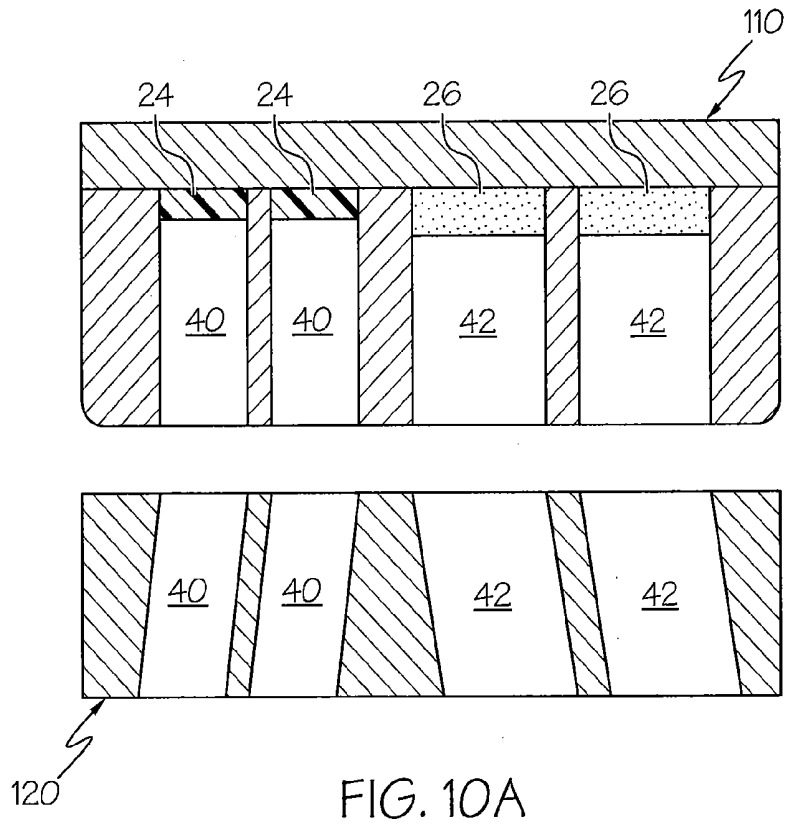

FIG. 10A

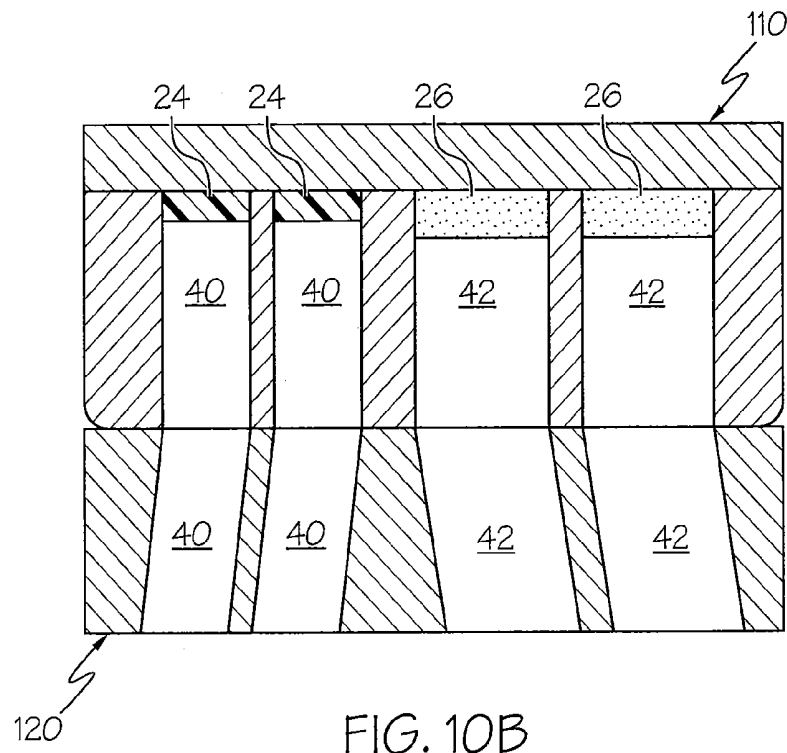

FIG. 10B

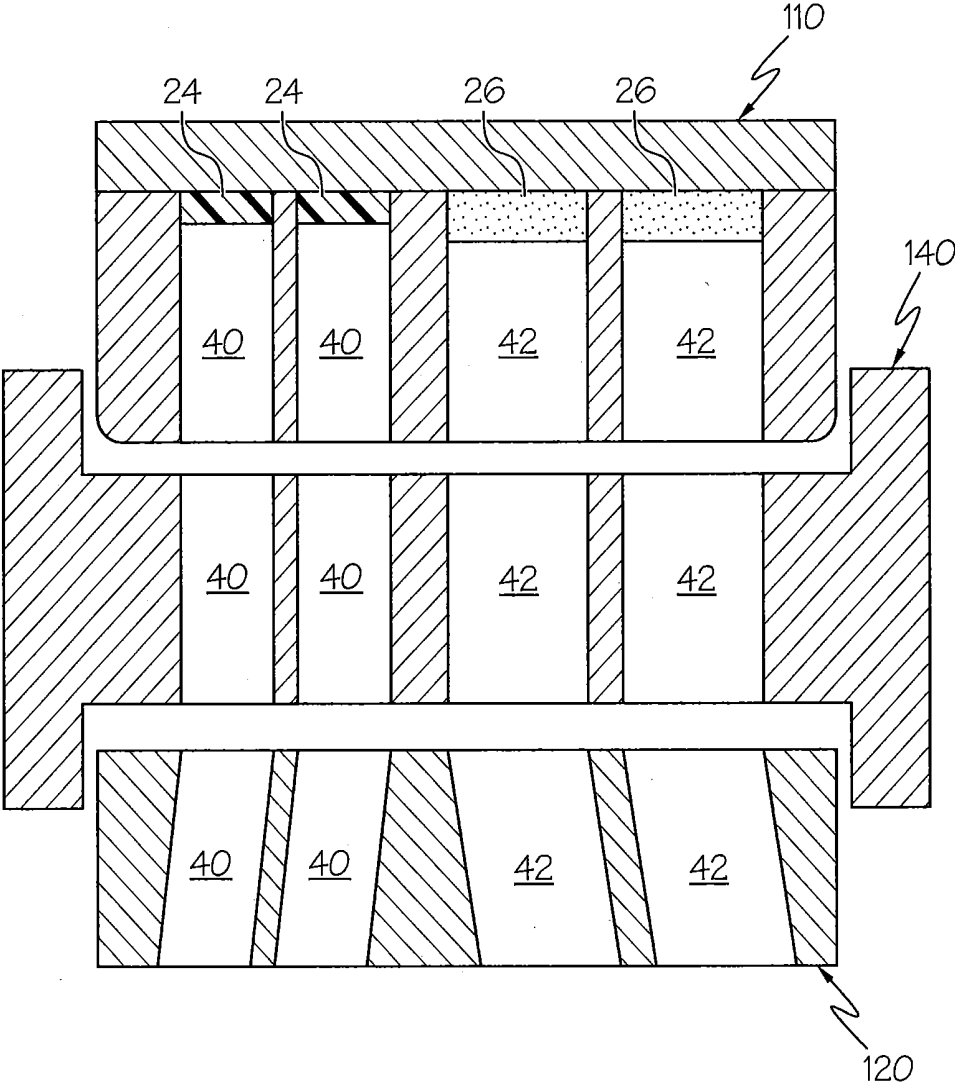

FIG. 11A

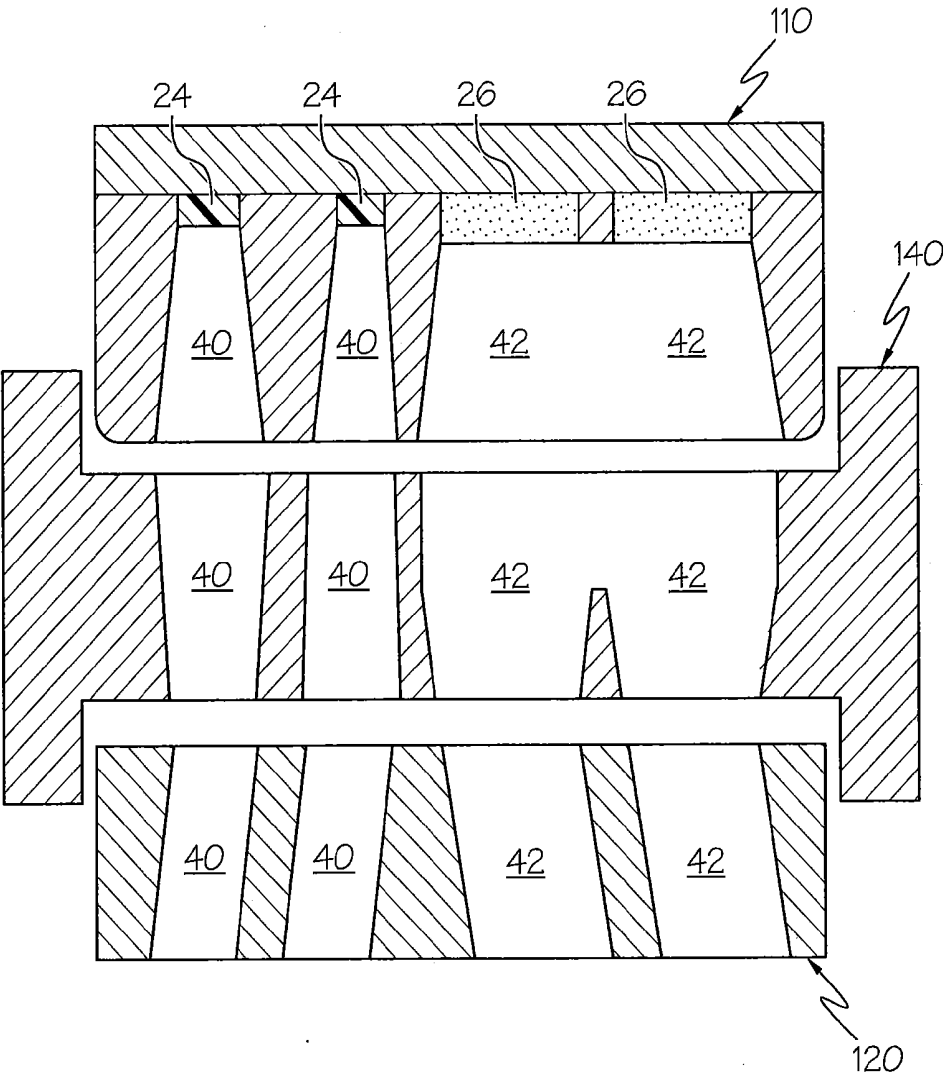

FIG. 11B

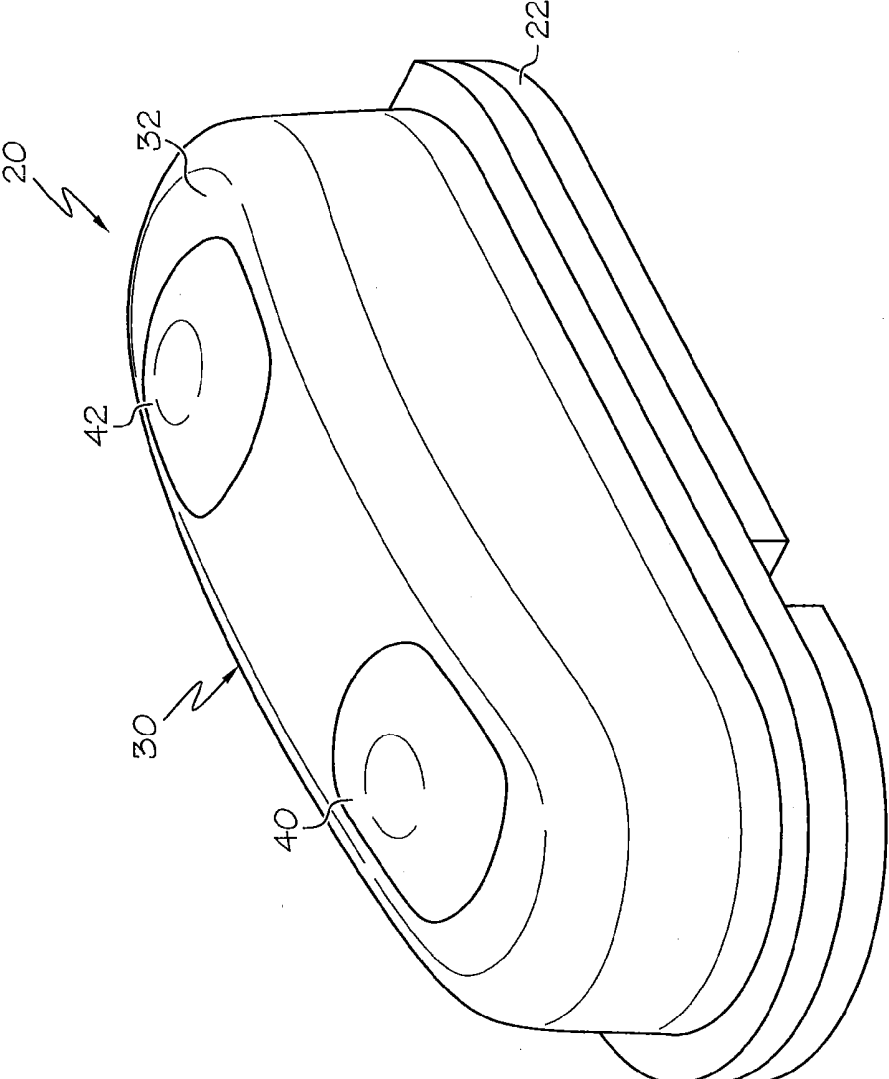

FIG. 12A

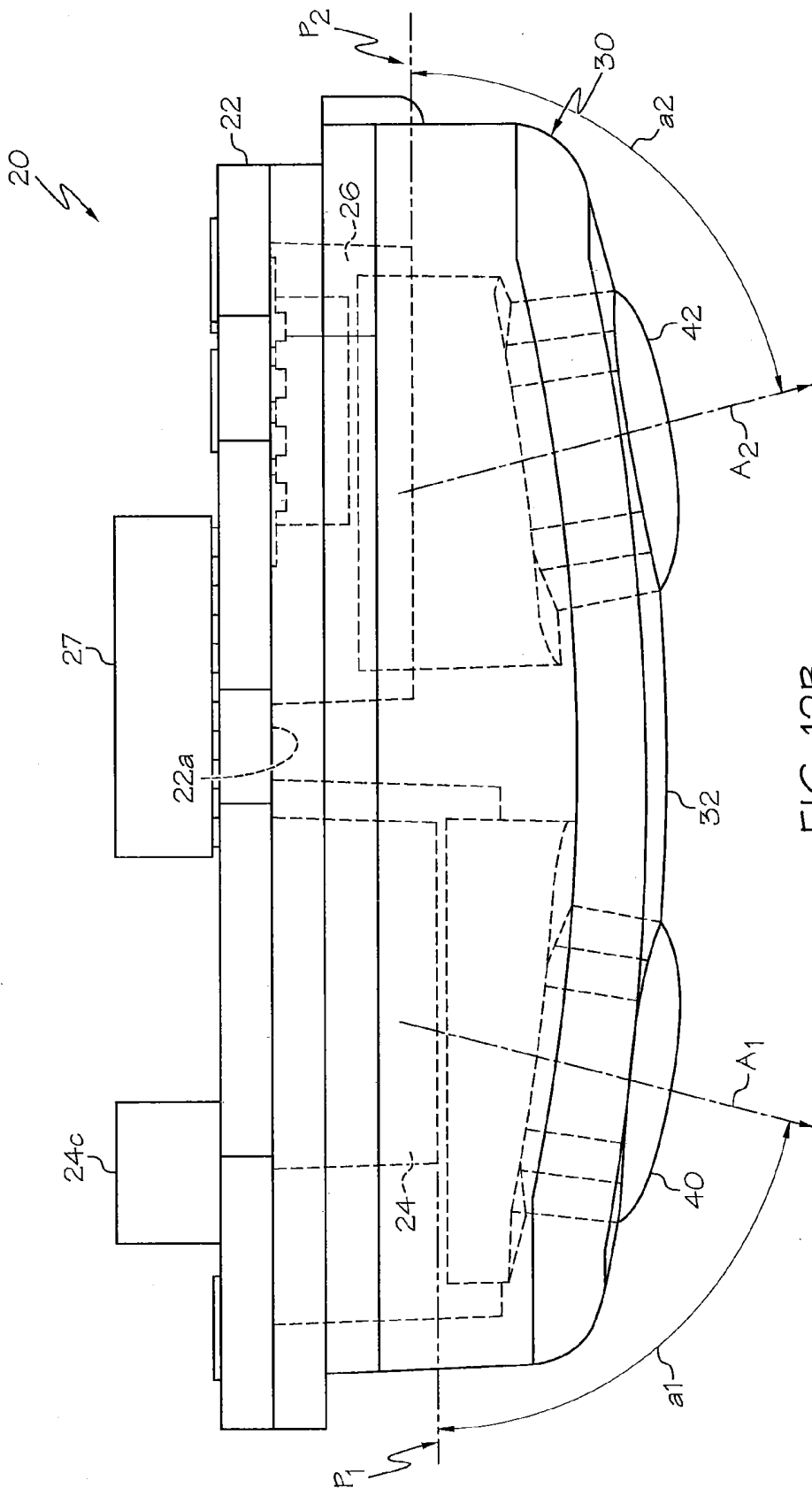

FIG. 12B

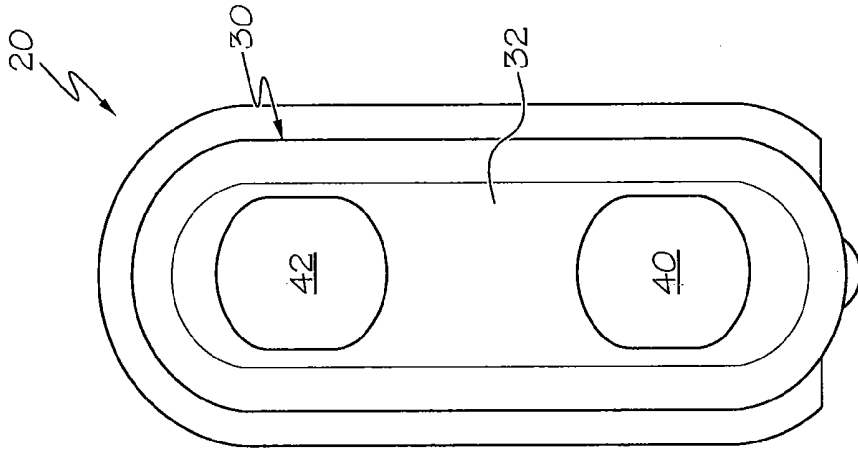

FIG. 12D

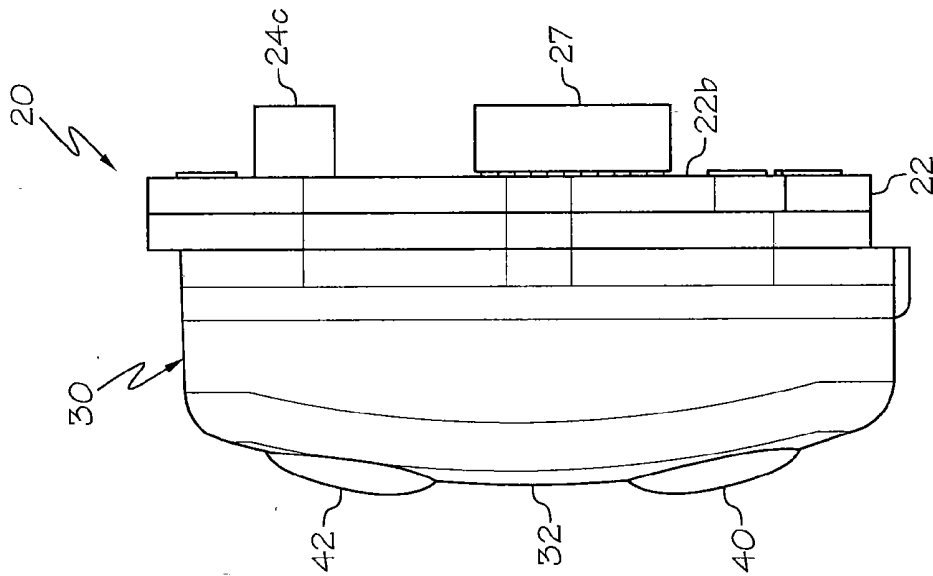

FIG. 12C

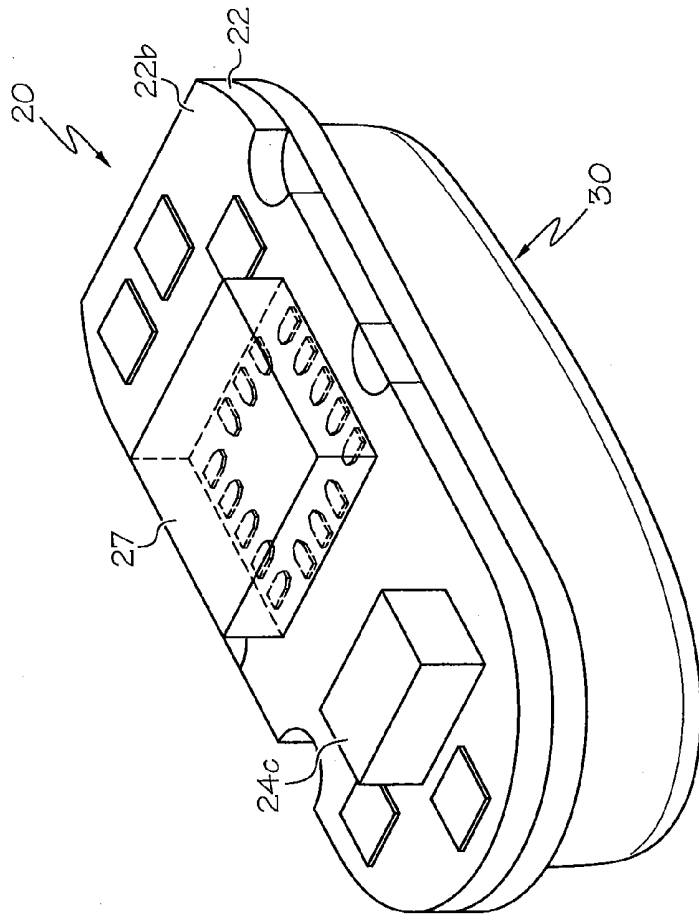

FIG. 12F

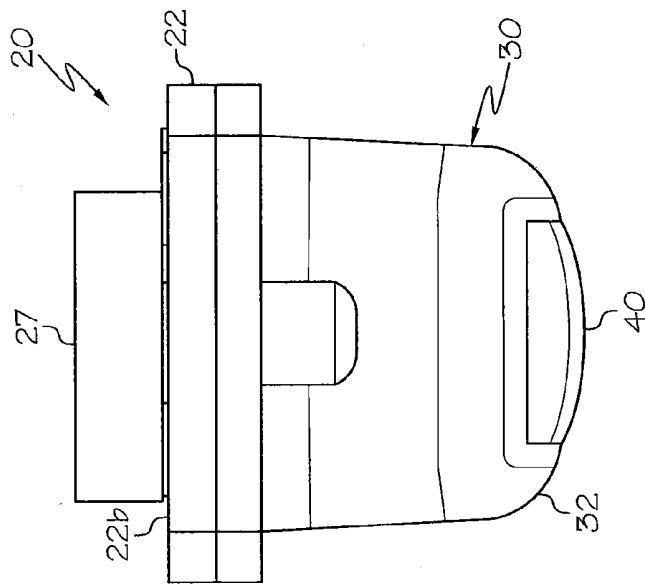

FIG. 12E

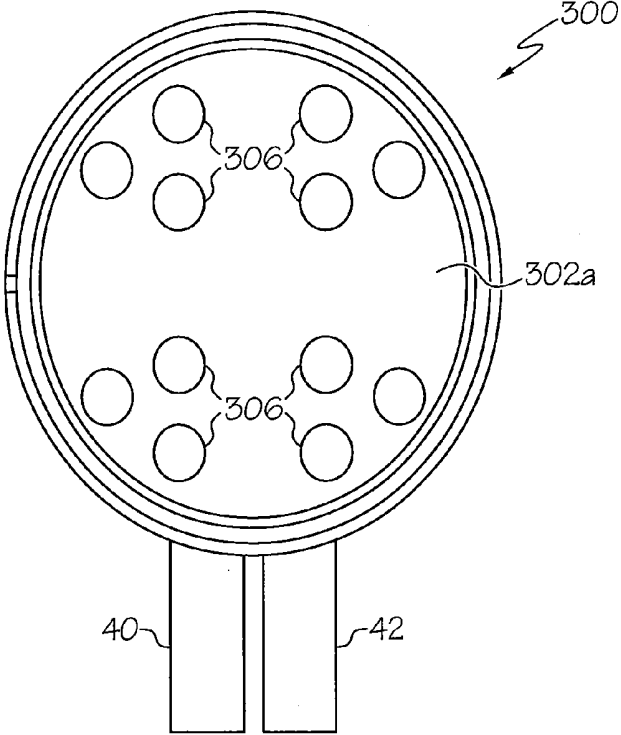

FIG. 13A

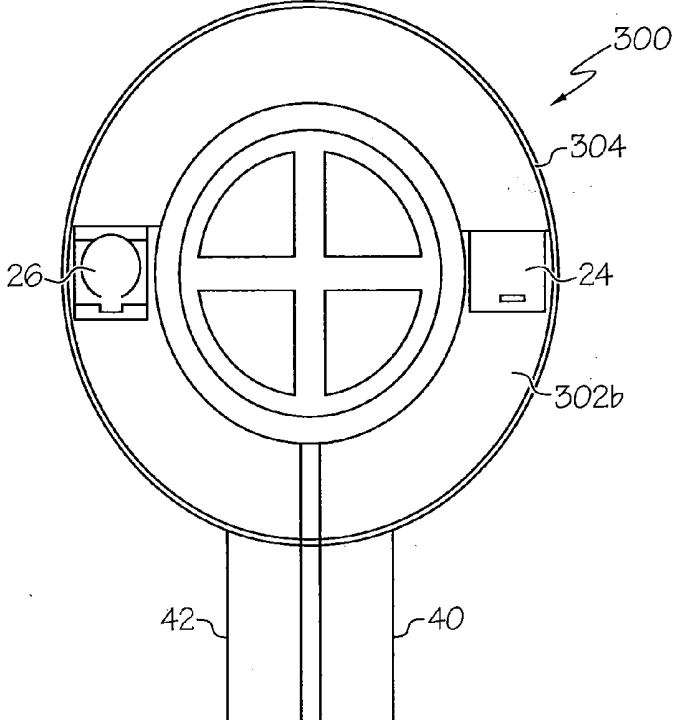

FIG. 13B

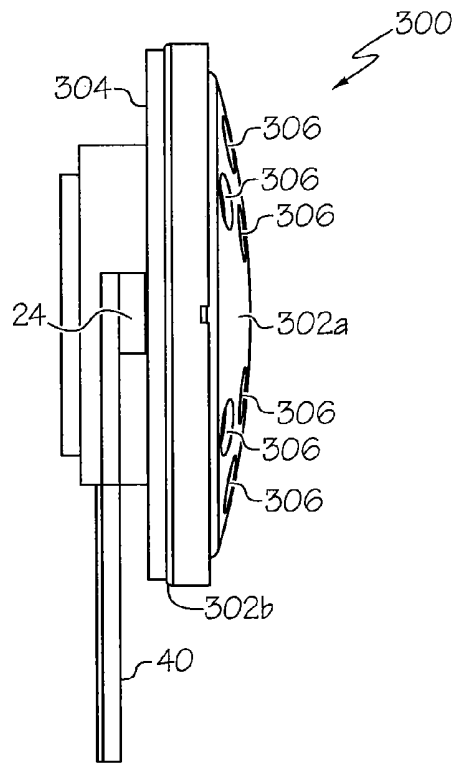

FIG. 13C

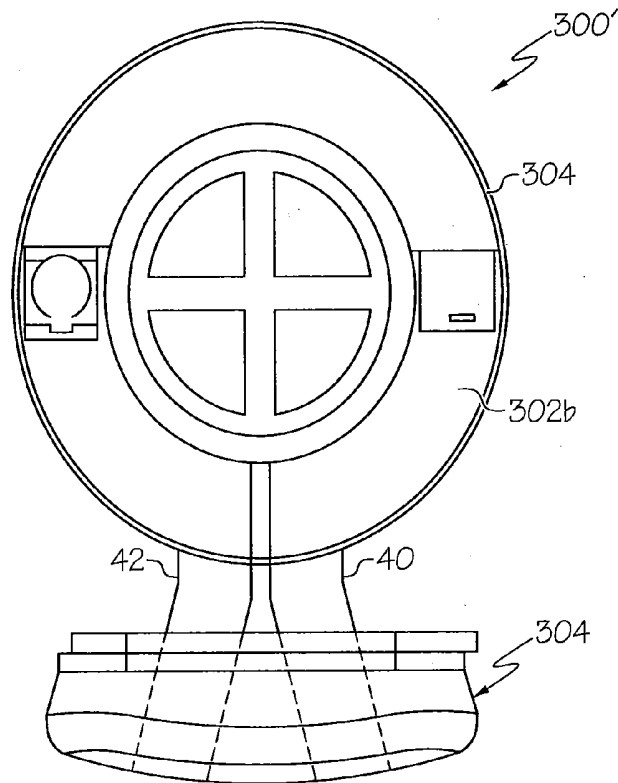

FIG. 13D

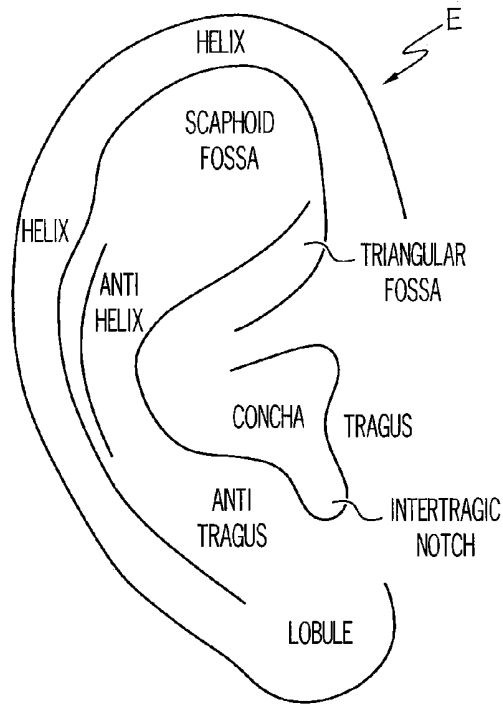

FIG. 14

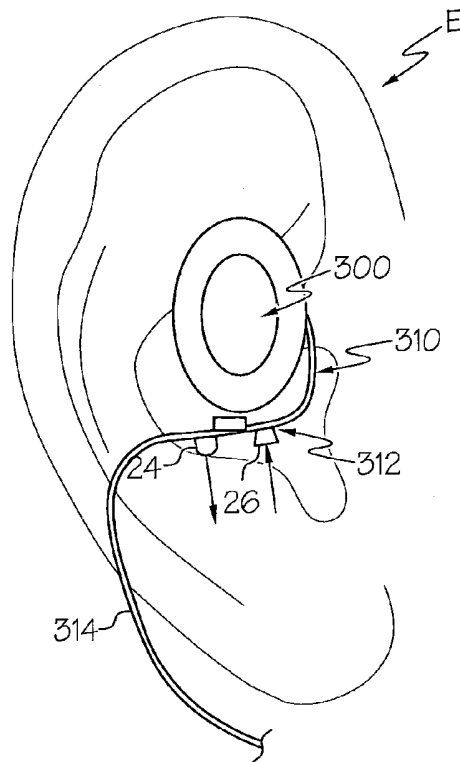

FIG. 15

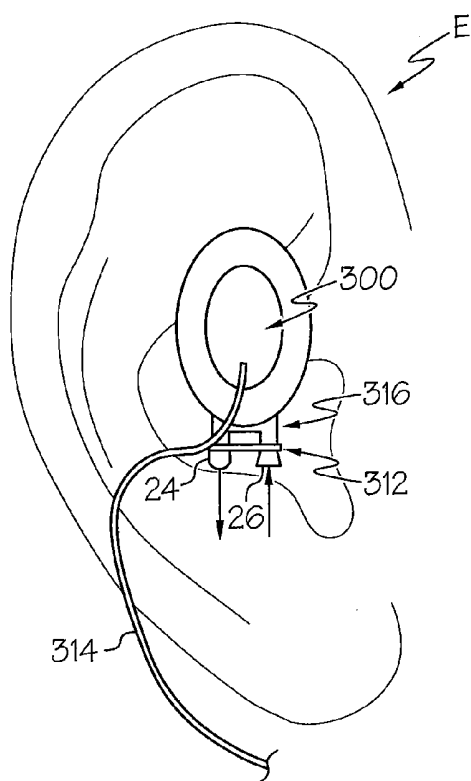

FIG. 16

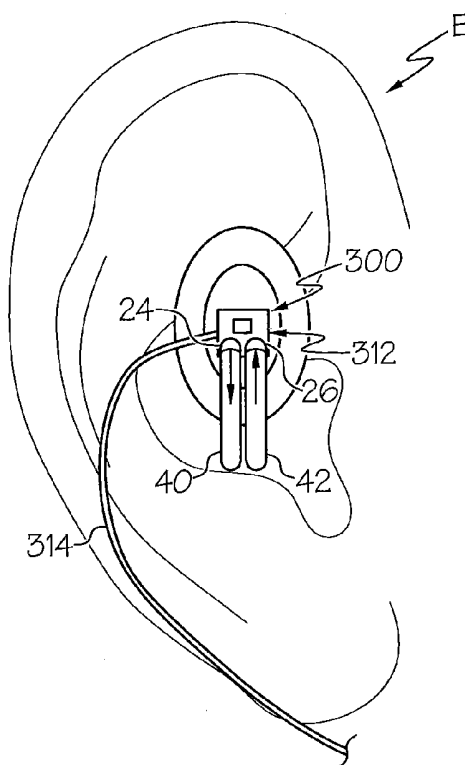

FIG. 17

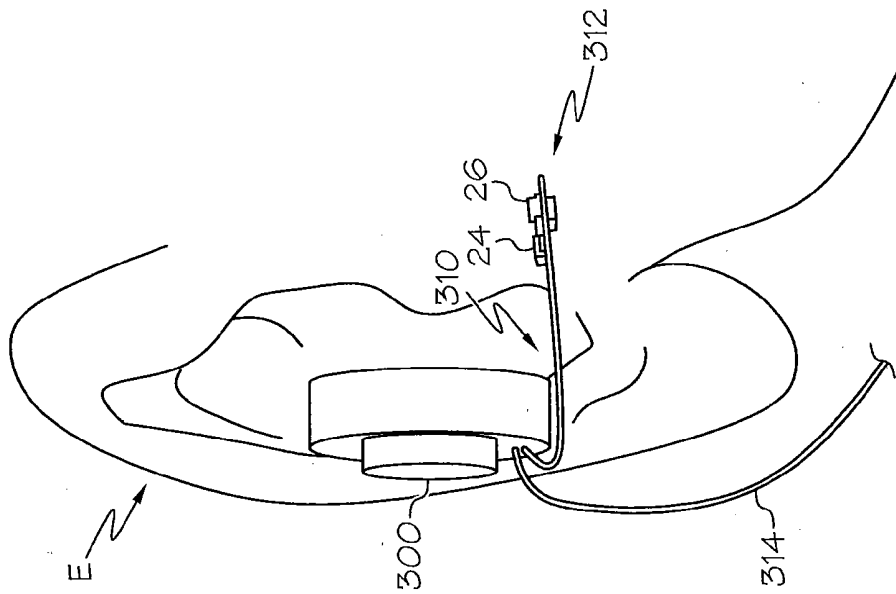

FIG. 18A

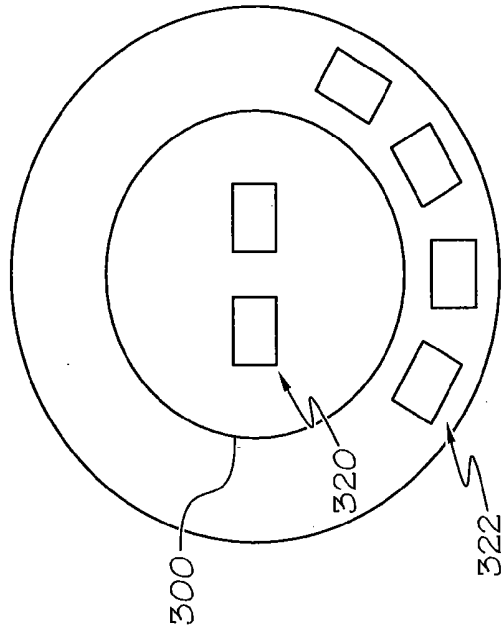

FIG. 18B

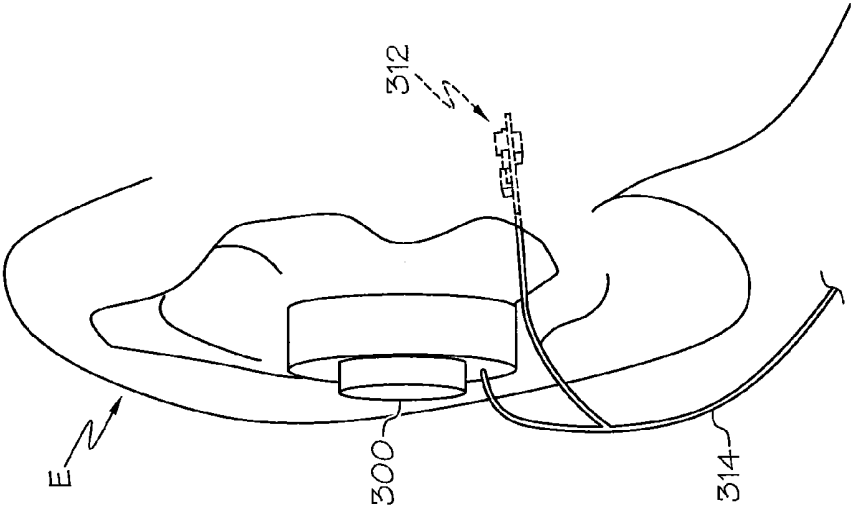

FIG. 20

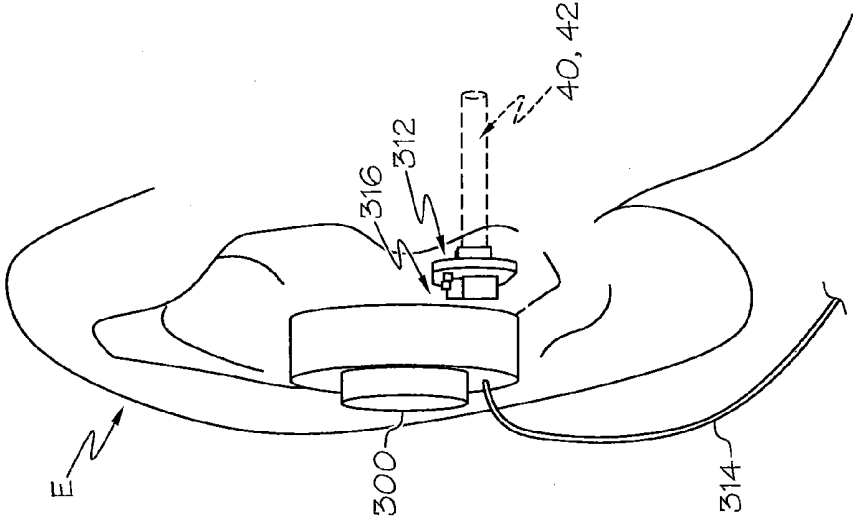

FIG. 19

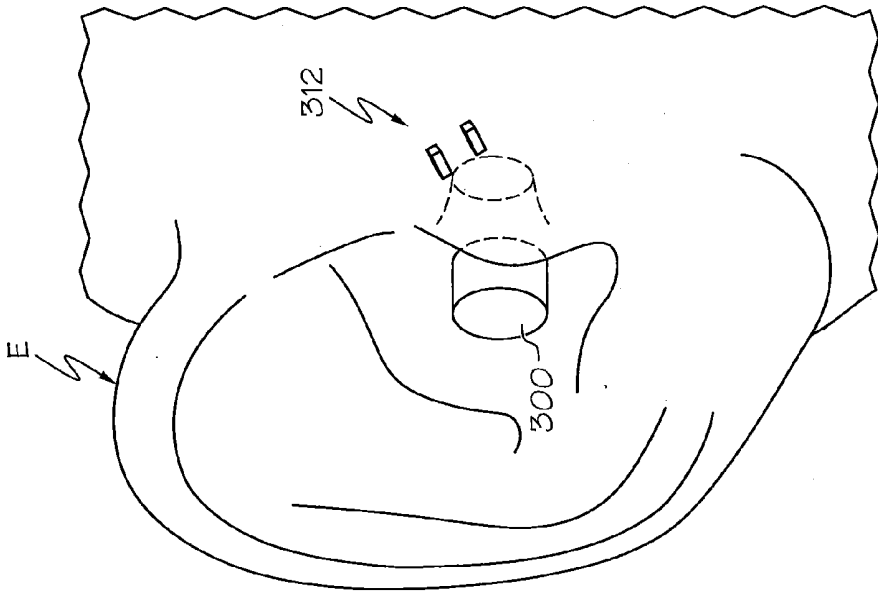

FIG. 21B

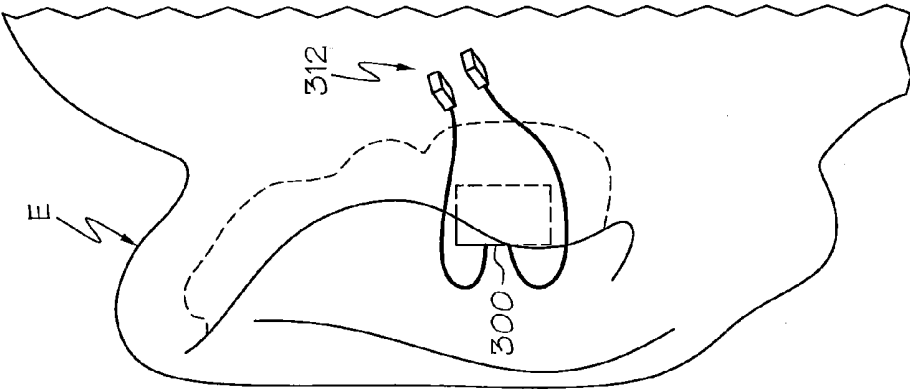

FIG. 21A

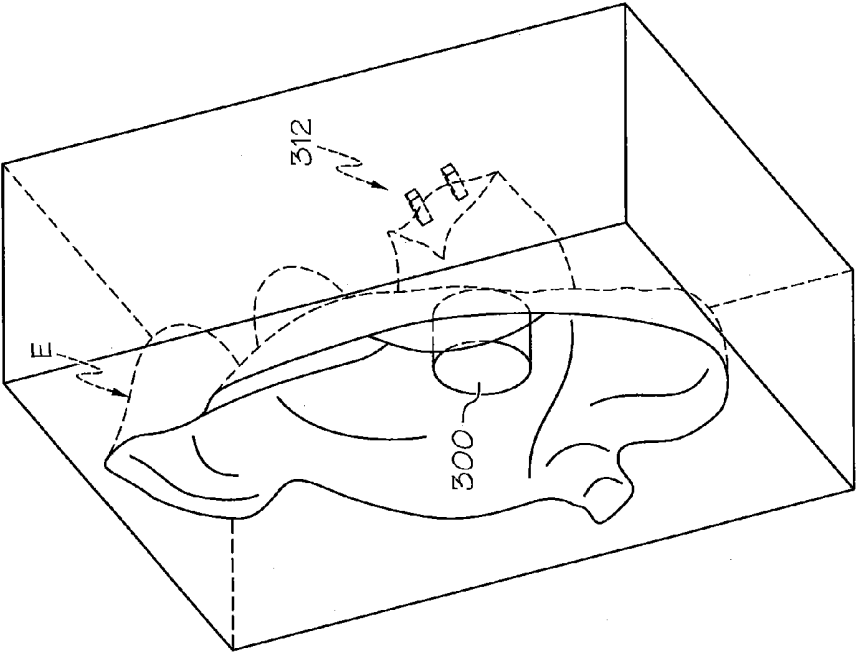

FIG. 22B

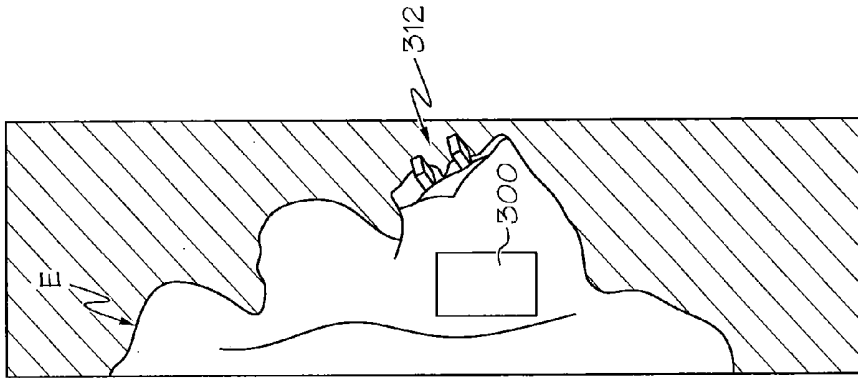

FIG. 22A

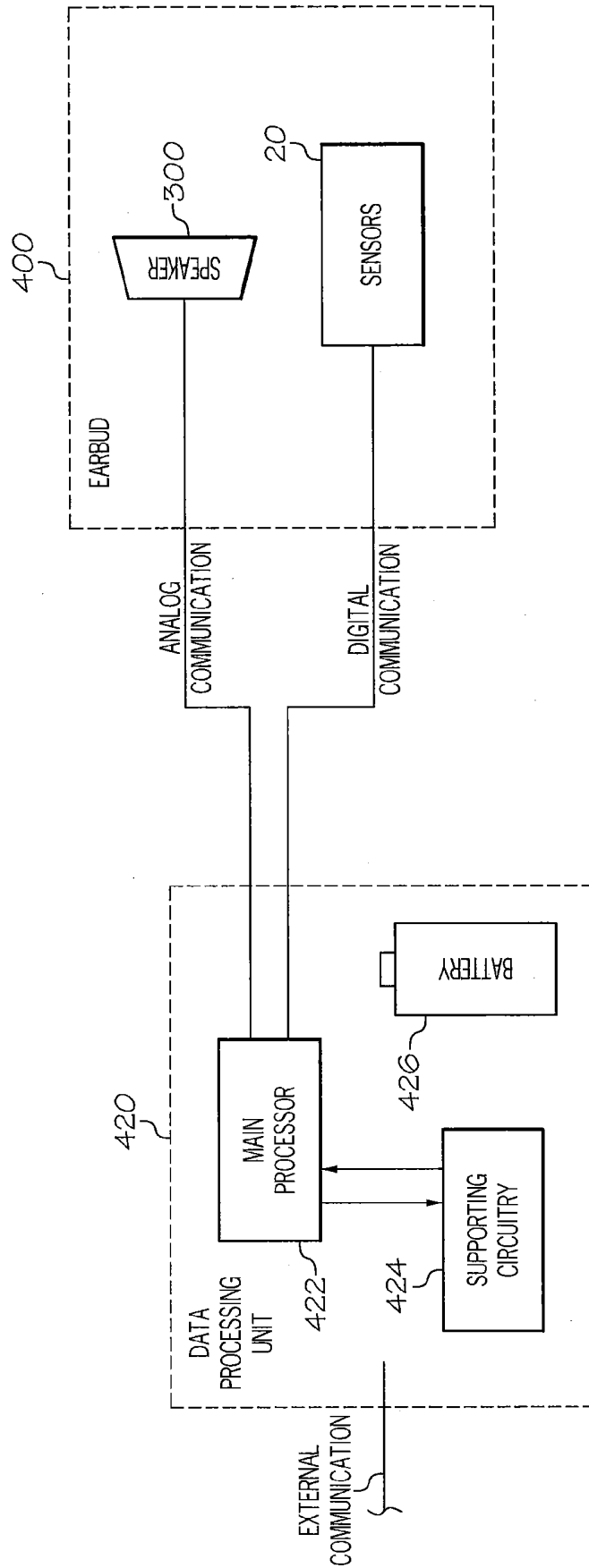

FIG. 23

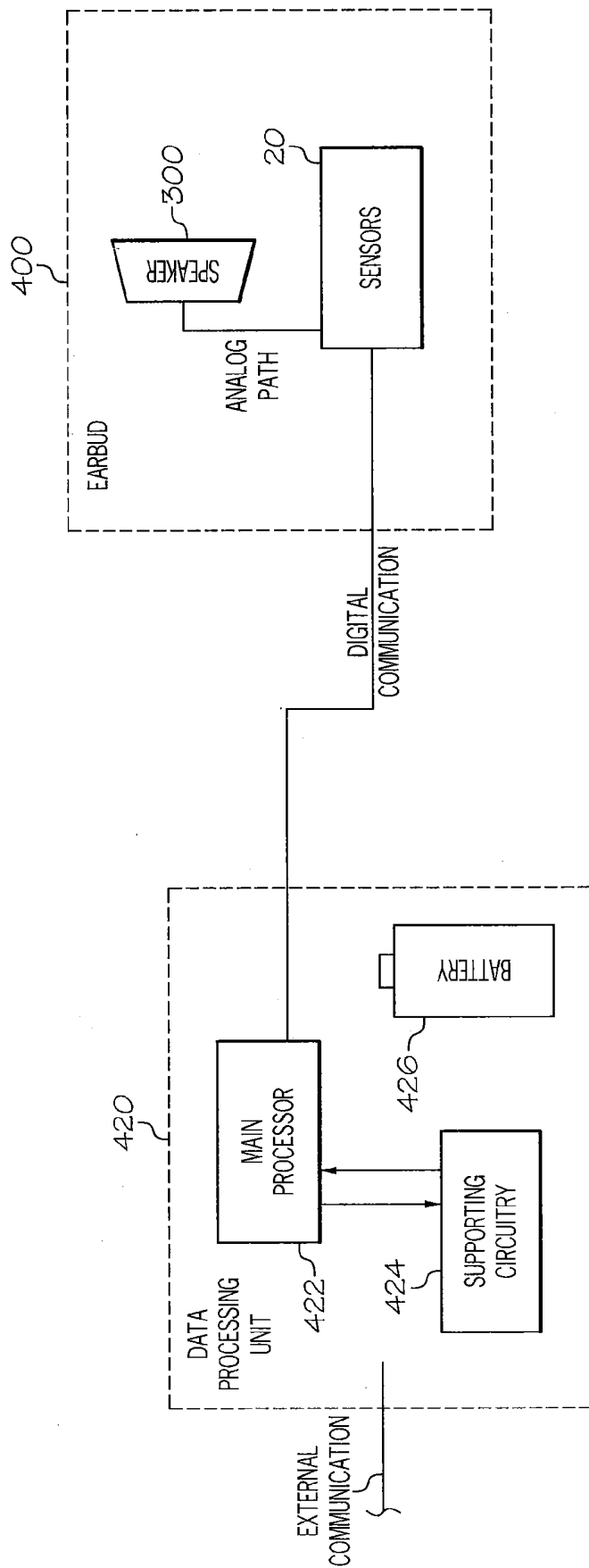

FIG. 24

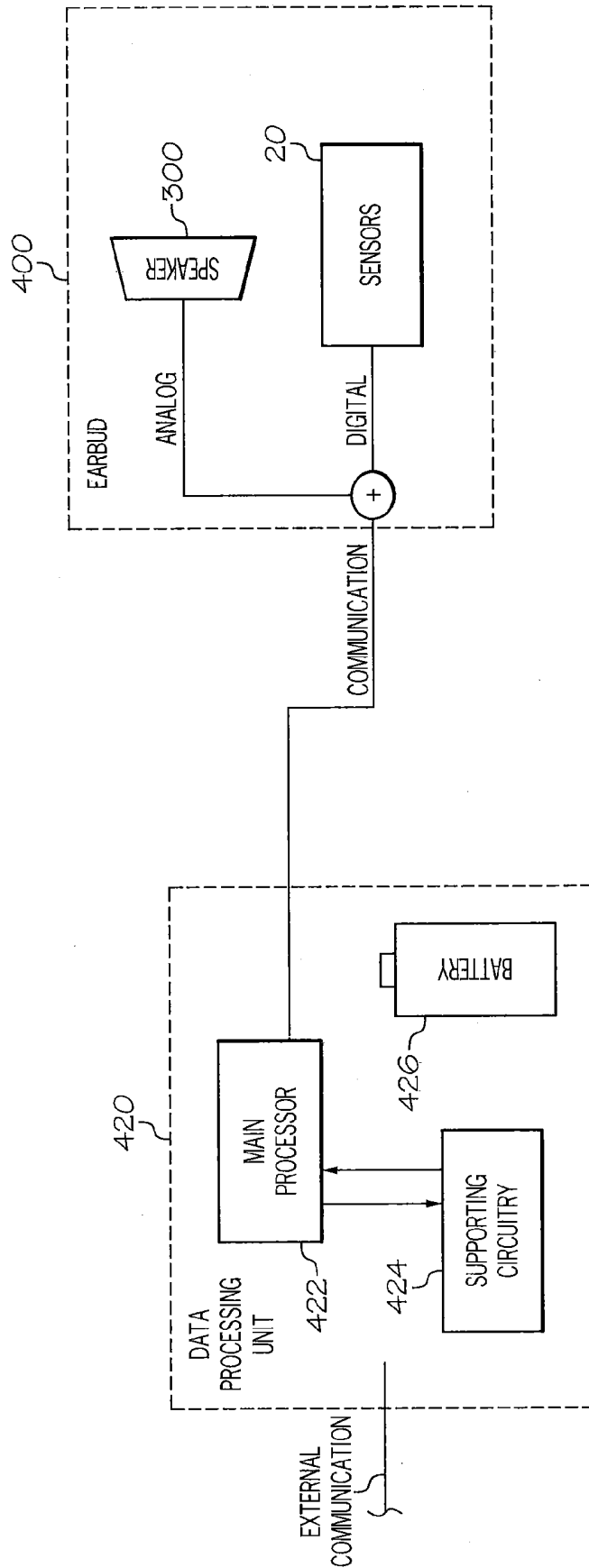

FIG. 25

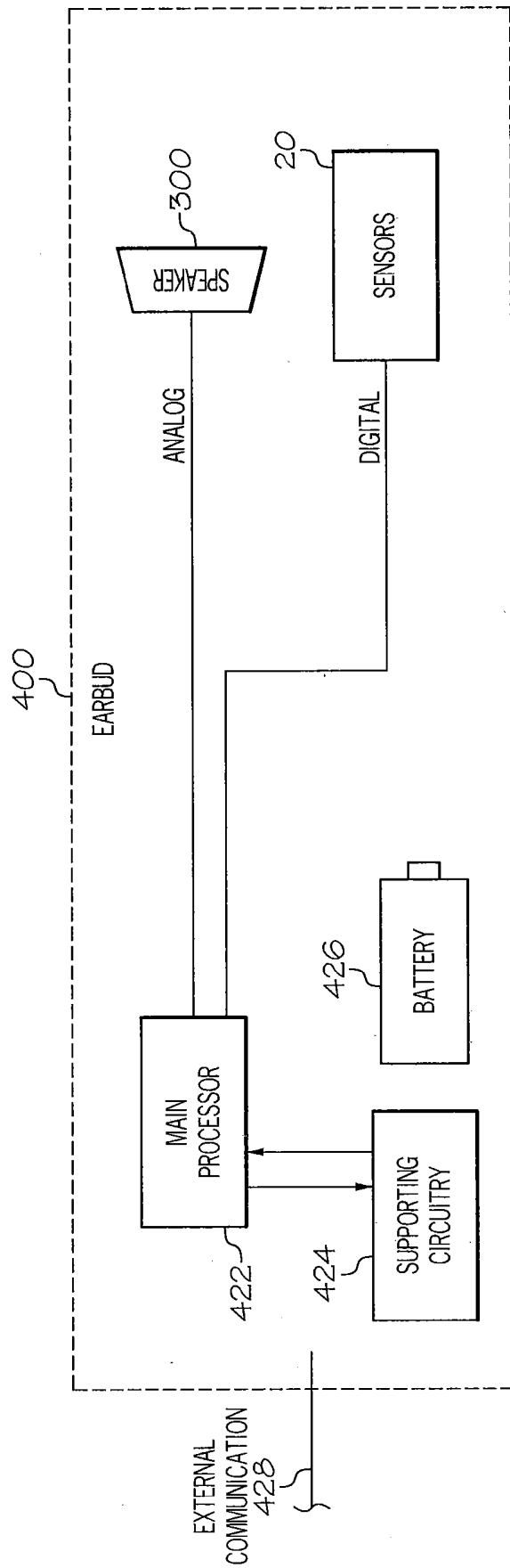

FIG. 26

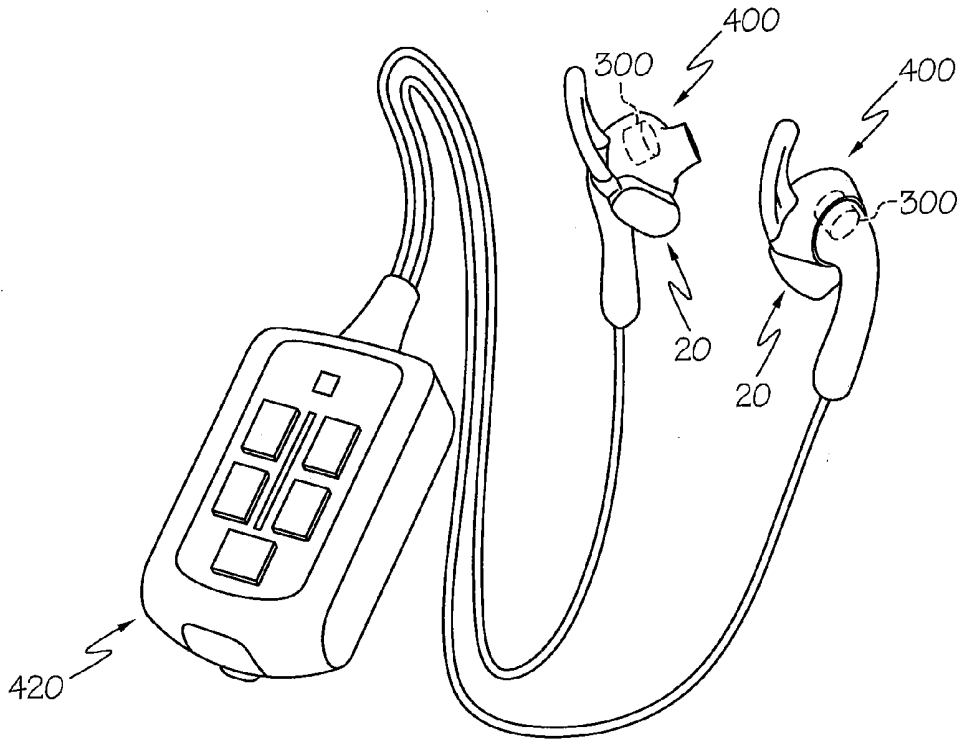

FIG. 27

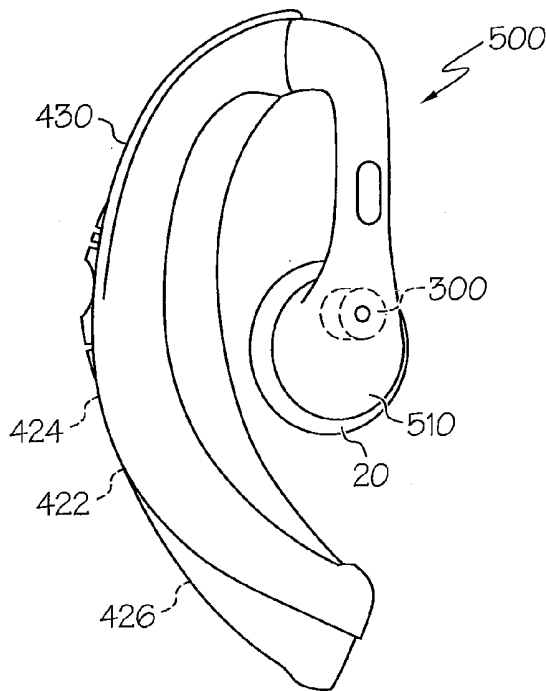

FIG. 28

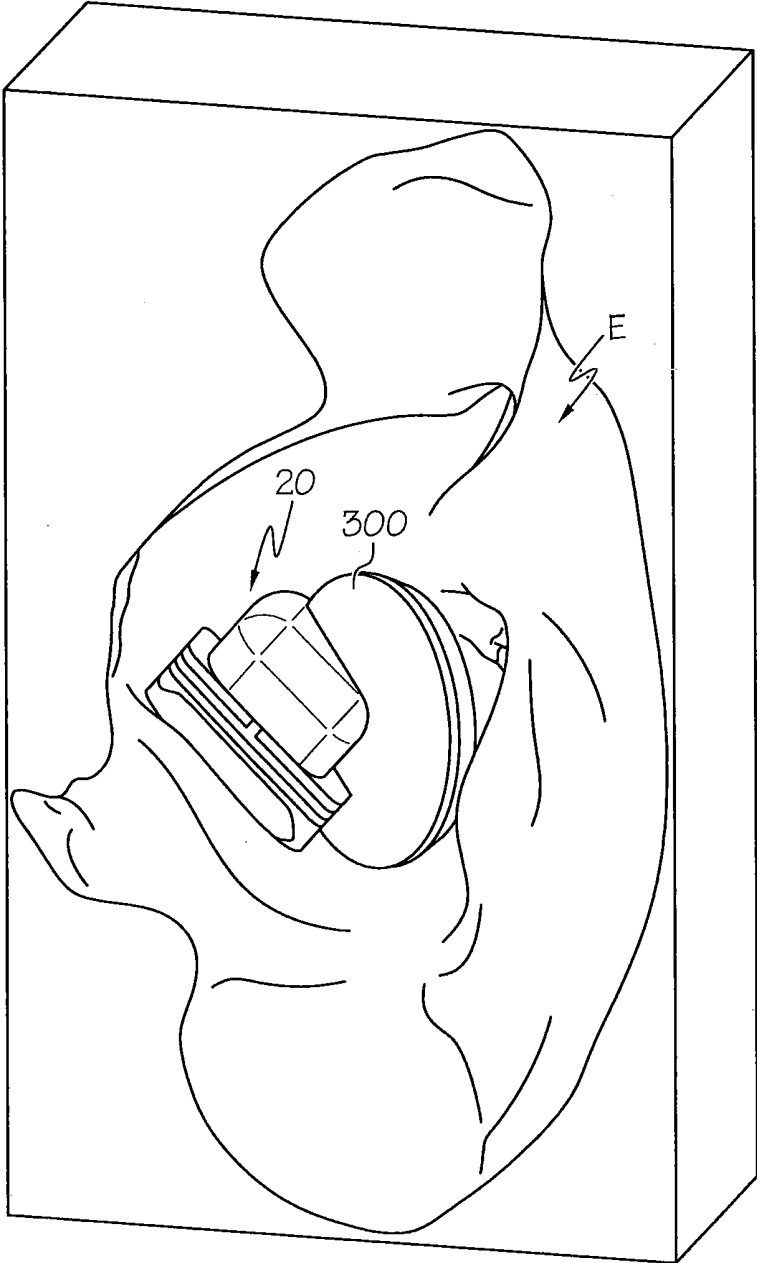

FIG. 29

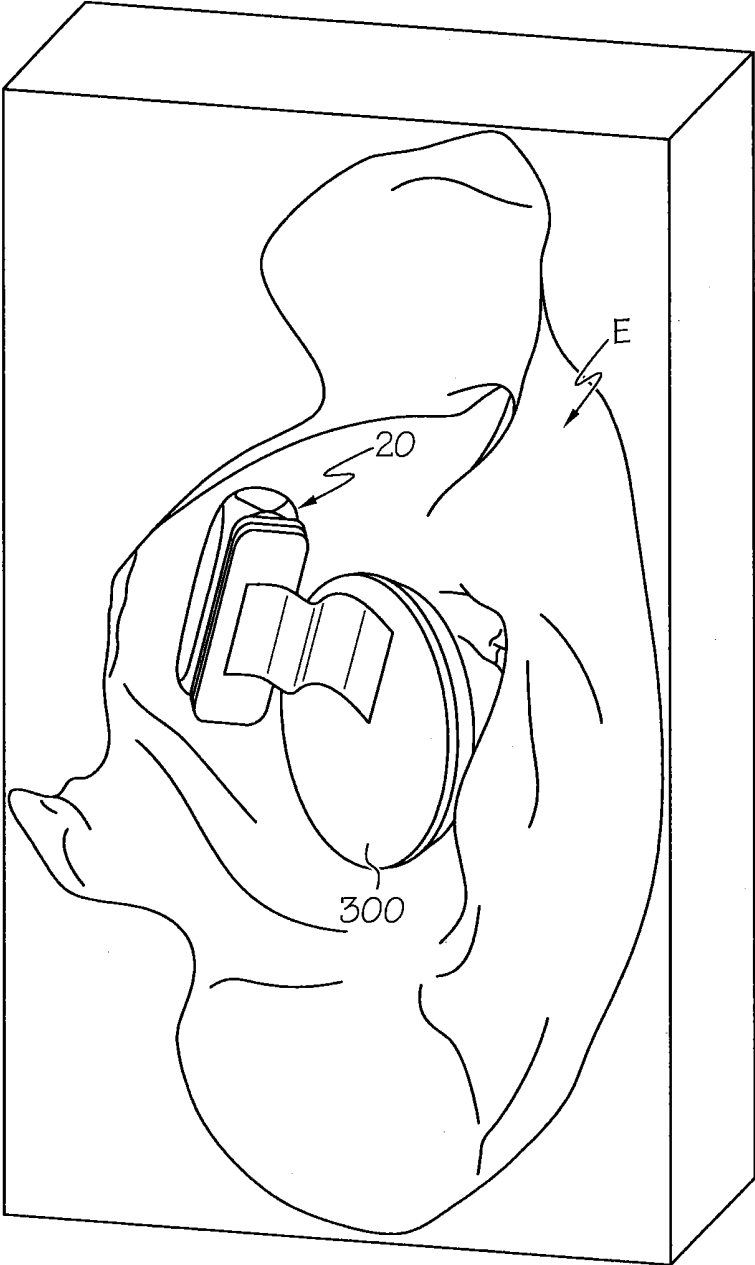

FIG. 30

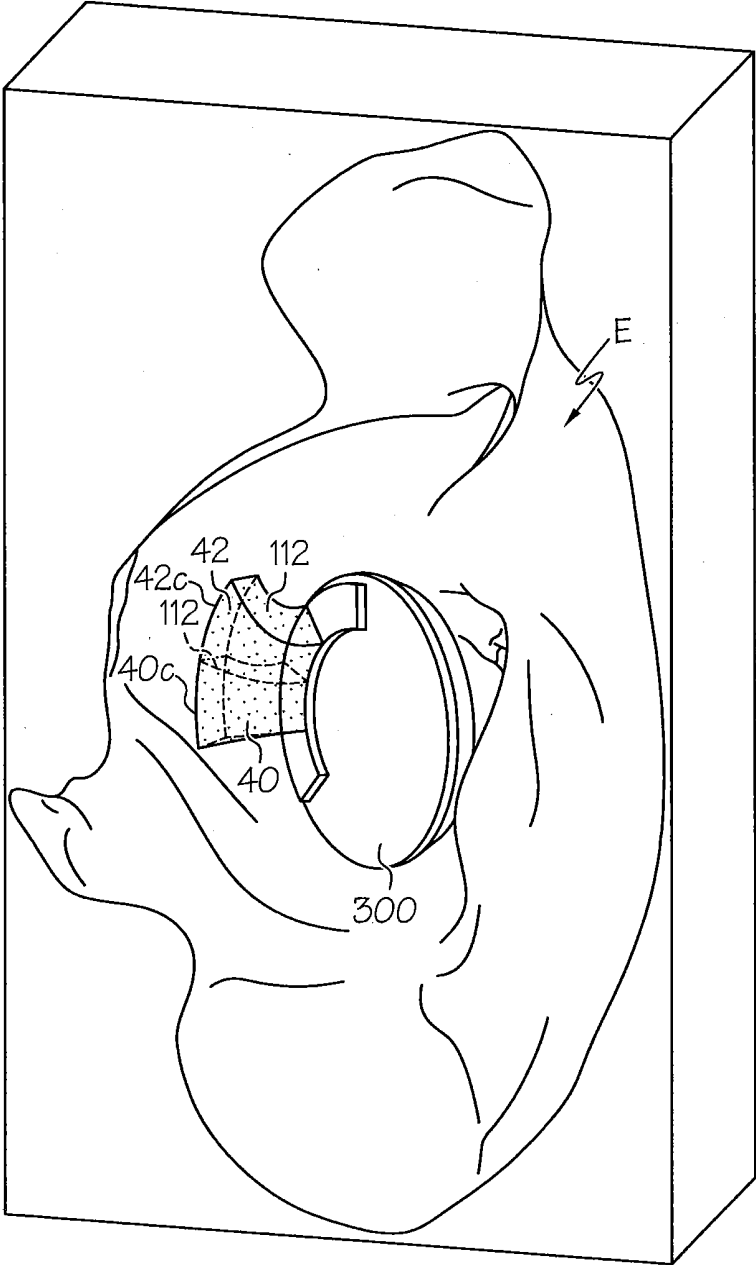

FIG. 31

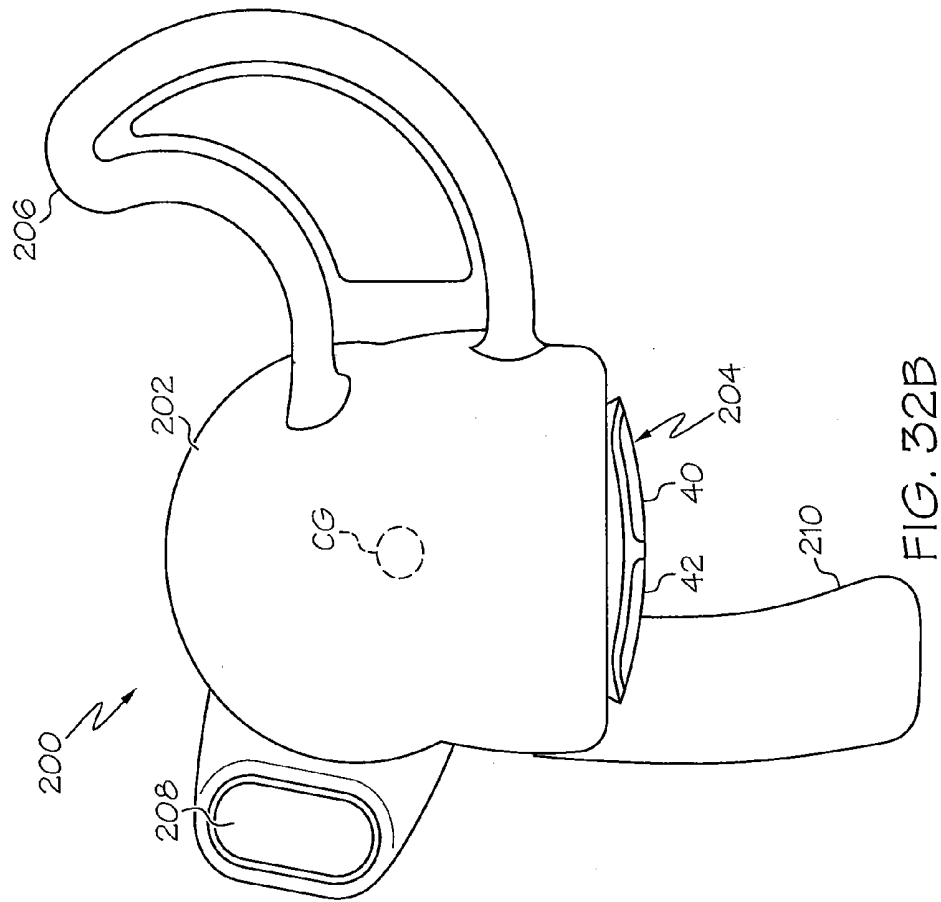

FIG. 32B

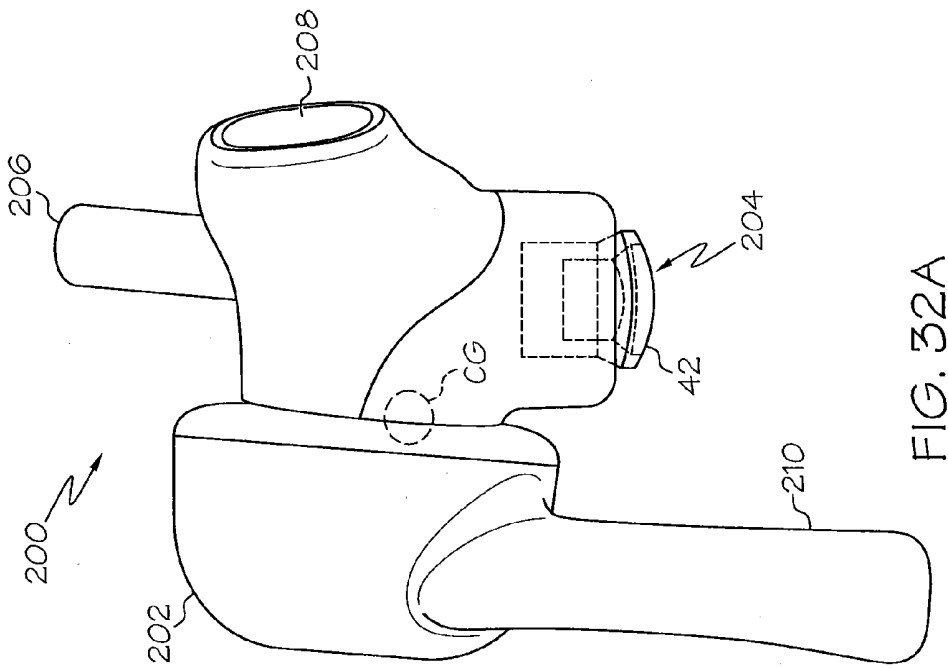

FIG. 32A

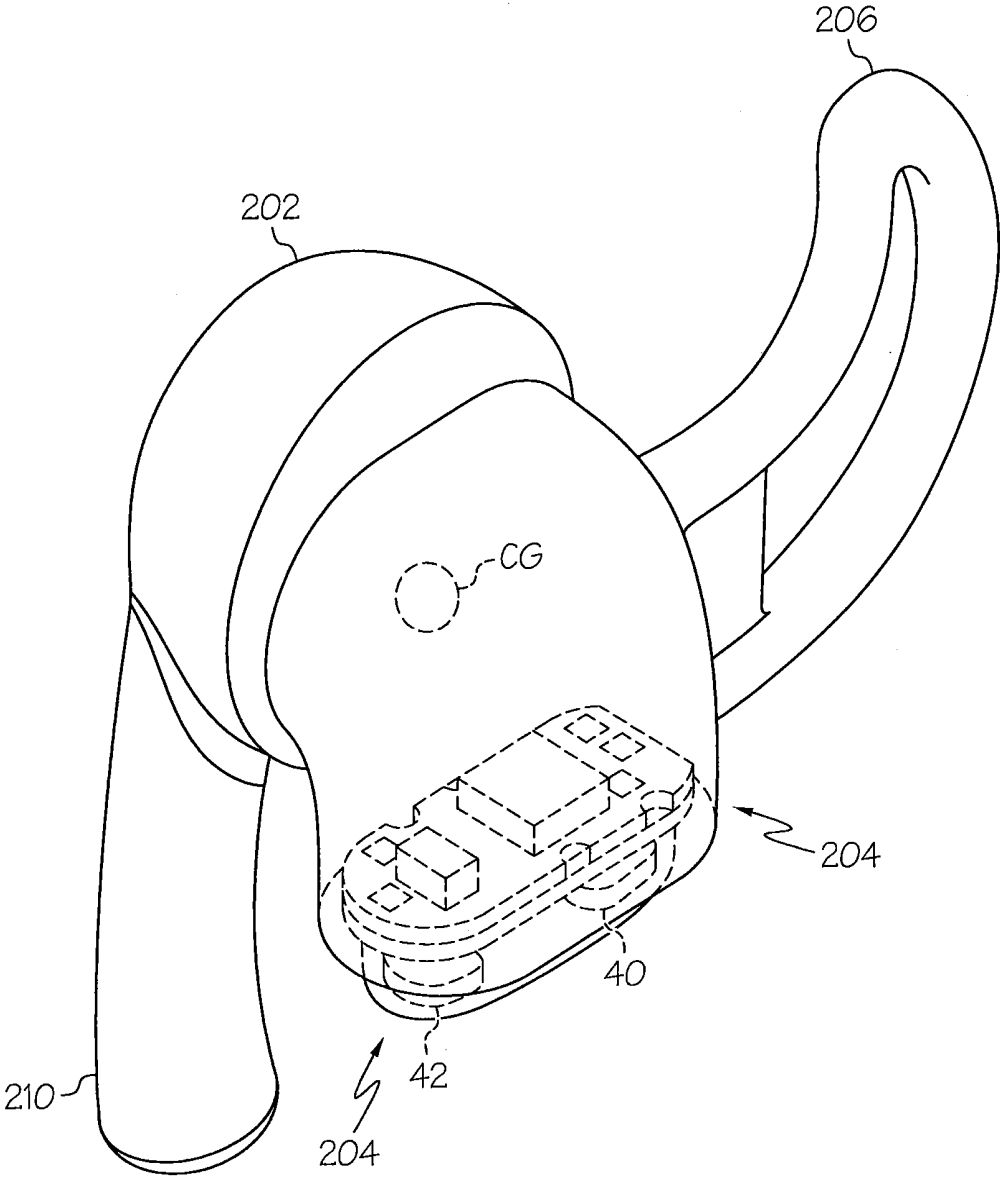

FIG. 32C

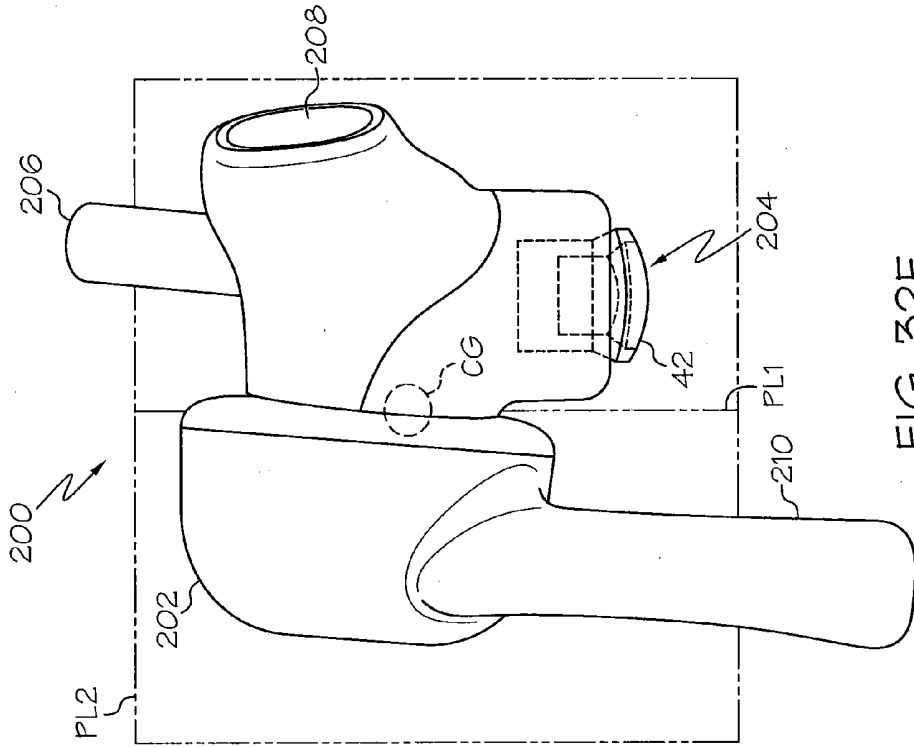

FIG. 32E

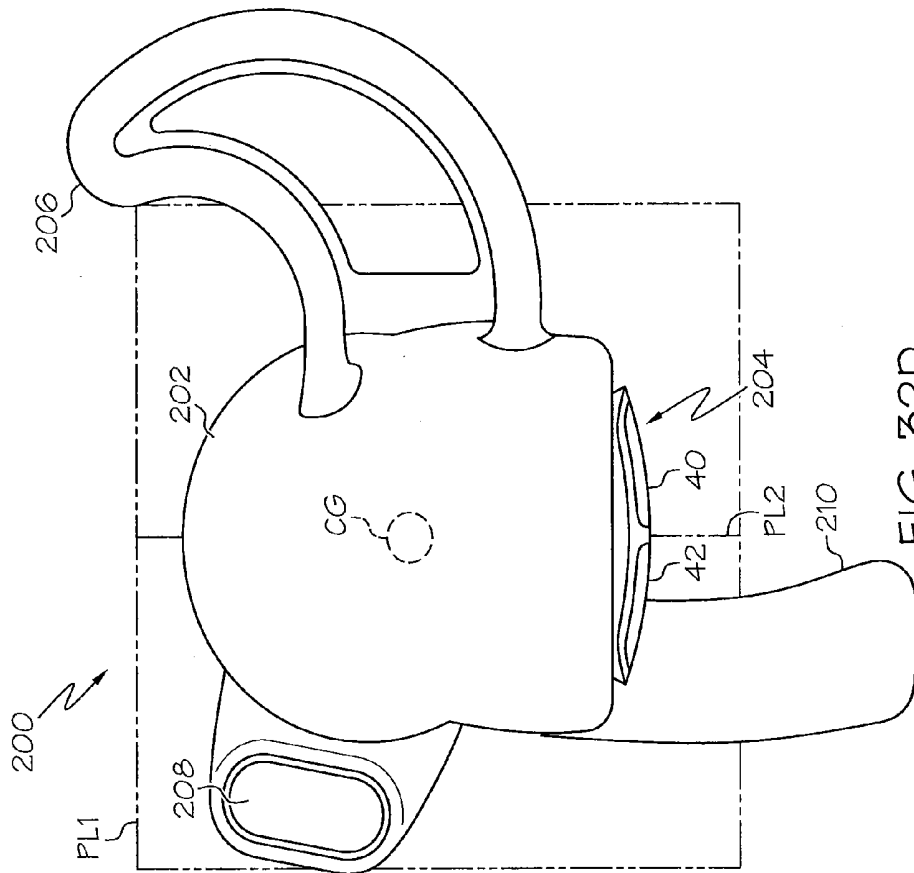

FIG. 32D

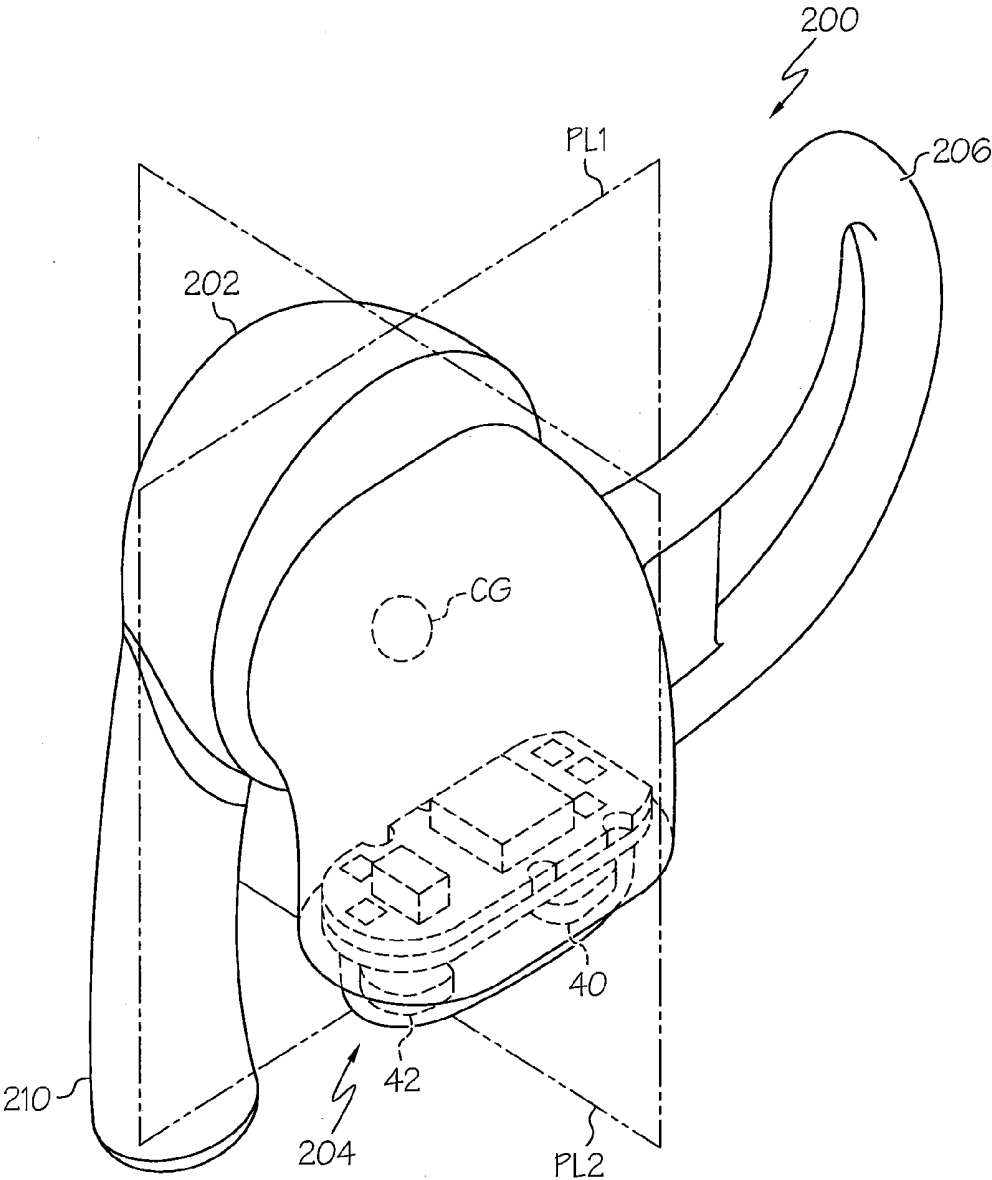

FIG. 32F

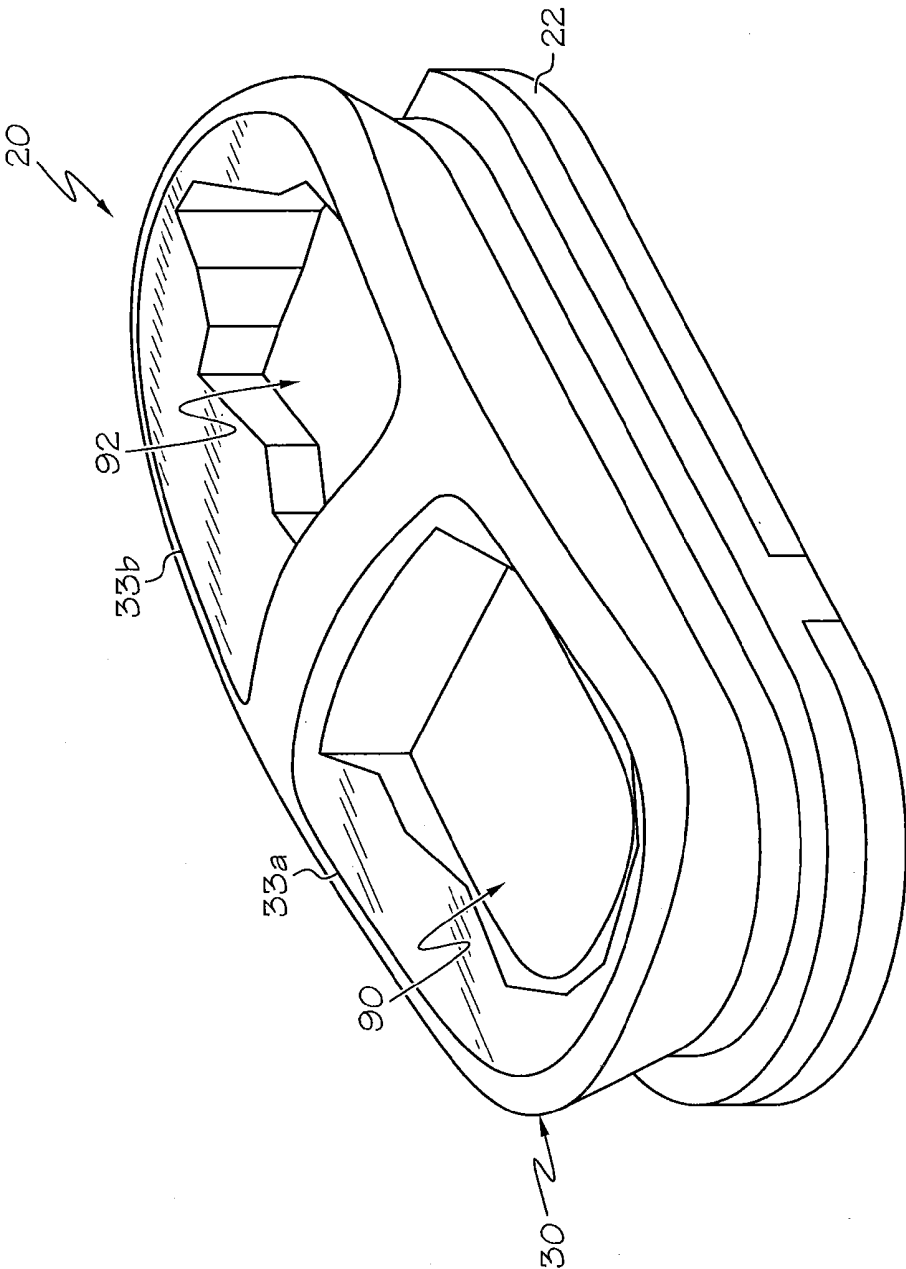

FIG. 33



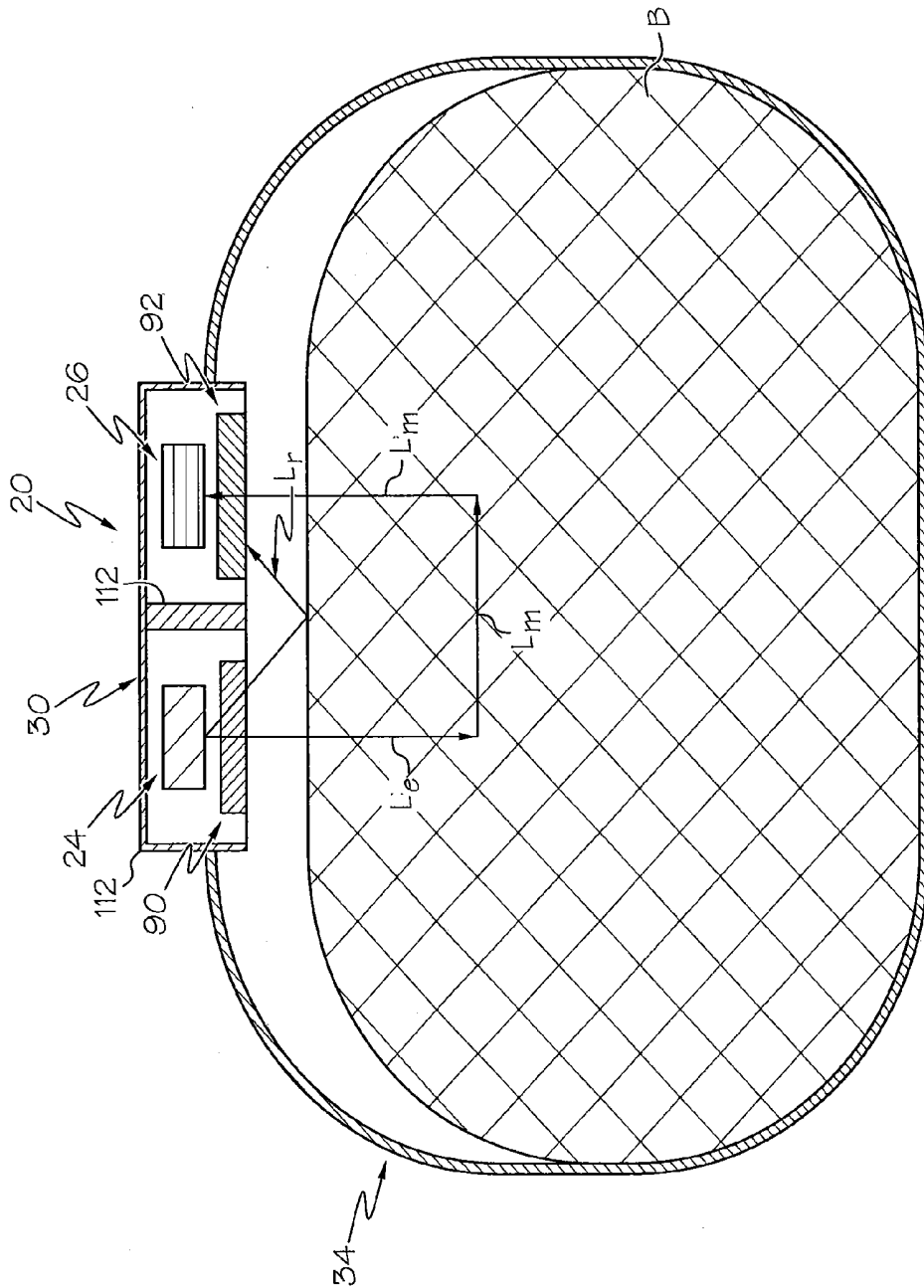

FIG. 35

## OPTICAL MONITORING APPARATUS AND METHODS

### RELATED APPLICATIONS

[0001] This application is a continuation of U.S. patent application Ser. No. 15/324,139, filed Jan. 5, 2017, which is a 35 U.S.C. §371 national stage application of PCT Application No. PCT/US2015/041562, filed on Jul. 22, 2015, which claims the benefit of and priority to U.S. Provisional Patent Application No. 62/033,922 filed Aug. 6, 2014, the disclosures of which are incorporated herein by reference as if set forth in their entireties.

### FIELD OF THE INVENTION

[0002] The present invention relates generally to monitoring devices and, more particularly, to optical sensor devices.

### BACKGROUND OF THE INVENTION

[0003] There is growing market demand for personal health and environmental monitors, for example, for gauging overall health and metabolism during exercise, athletic training, dieting, daily life activities, sickness, and physical therapy. However, traditional health monitors and environmental monitors may be bulky, rigid, and uncomfortable—generally not suitable for use during daily physical activity.

[0004] Sensors for detecting biometric signals, such as vital signs and other physiological information, are configured to isolate the biometric signals from other spurious signals and deliver biometric readings, such as heart rate, respiration rate, blood pressure, etc., to the user. Unfortunately, spurious signals that may be difficult to isolate from a biometric signal are associated with physical movement (e.g., physical exercise, such as walking, running, daily activities, etc.) of a sensor relative to the user or the environment of the user (e.g., sunlight, room light, humidity, ambient acoustical or electromagnetic noise, temperature extremes or changes in temperature, etc.).

[0005] For example, referring to FIG. 1, a conventional photoplethysmography (PPG) optical sensor 10 is illustrated that includes an optical source 14, and an optical detector 16. The optical sensor 10 is desirably positioned directly against the body B (i.e., the skin) of a subject wearing the optical sensor such that light  $L_1$  from the optical source 14 is directed into the body B and is subsequently detected by the optical detector 16. However, movement of the user can cause the sensor 10 to move relative to the body B such that light  $L_2$  can take a direct path from the optical source 14 into the optical detector 16 (for example by reflection off of the body, i.e., the skin, of the user), which increases spurious signals. Moreover, motion artifacts may cause the distance between the sensor 10 and body B to change in time, thereby modulating  $L_1$  and  $L_2$  in time, leading to motion artifact noise on the signal generated by the detector 16.

[0006] Previous ways of isolating heart rate signals from other signals include the use of passive and active signal processing algorithms, increasing optical sensor output and displacing the optical source from the photodetector, and pushing the sensor more firmly against the user so as to limit the effects of physical movement on the heart rate signal.

### SUMMARY

[0007] It should be appreciated that this Summary is provided to introduce a selection of concepts in a simplified

form, the concepts being further described below in the Detailed Description. This Summary is not intended to identify key features or essential features of this disclosure, nor is it intended to limit the scope of the invention.

[0008] According to some embodiments of the present invention, a wearable optical sensor includes at least one optical emitter, at least one optical detector and light-guiding optics. The light-guiding optics are configured to direct a beam pattern of light upon a body of a subject wearing the optical sensor and to detect light scattered from a detection region of the body. In addition, the light-guiding optics are configured to prevent overlap between the beam pattern of light and the detection region when the wearable sensor is separated from the body, for example, by a distance up to about three tenths of a centimeter (0.3 cm). In some embodiments, the light-guiding optics includes optical filtering material and/or light polarizing material.

[0009] According to some embodiments of the present invention, an optical sensor module for detecting and/or measuring physiological information from a subject and that can be integrated into a wearable device, such as a headset (e.g., an earbud, etc.), an armband, a wristband, clothing, foot apparel, a ring, etc., includes a base and a housing secured to the base. The base includes an optical source and an optical detector. The housing overlies the optical source and optical detector and includes a first light guide comprising light transmissive material in optical communication with the optical source and a second light guide comprising light transmissive material in optical communication with the optical detector. The first and second light guides define respective first and second axial directions that are outwardly diverging. The first axial direction of the first light guide is angled relative to a plane defined by a surface of the optical source, and the second axial direction of the second light guide is angled relative to a plane defined by a surface of the optical detector. When the sensor module is in use and placed adjacent the skin of a user, a substantial majority of light rays emanating from the optical source and directed into the skin of the user cannot overlap with light rays returning through the skin of the user and collected by the second light guide when the housing is separated from the skin, for example, by a distance up to about three tenths of a centimeter (0.3 cm).

[0010] In some embodiments, at least one of the first and second light guides is cylindrical. In other embodiments, at least one of the first and second light guides is non-cylindrical.

[0011] The first and second light guides include opposite proximal and distal ends. In some embodiments, the proximal and distal ends of at least one of the first and second light guides have different sizes. For example, the diameter of a light guide distal end may be greater than a diameter of the proximal end thereof. Alternatively, the diameter of a light guide distal end may be smaller than a diameter of the proximal end thereof. In some embodiments, the proximal and distal ends of at least one of the first and second light guides may have different configurations. For example, the proximal end of a light guide may have one type of geometric configuration and the distal end may have a different geometric configuration. As an example, the proximal end may have a triangular configuration and the distal end may have a rectangular configuration, etc.

[0012] In some embodiments, the distal end of at least one of the first and second light guides has a curved surface. In

other embodiments, the distal end of at least one of the first and second light guides has a textured surface.

**[0013]** In some embodiments, multiple light guides may be substituted for a single light guide either on the optical source or over the optical detector.

**[0014]** In some embodiments, single or multiple light guides may be placed over multiple optical sources or multiple optical detectors.

**[0015]** Optical sensor modules according to embodiments of the present invention are advantageous because they can lower the sensitivity of an optical signal to sensor-user movement related noise, thereby enabling a significant improvement in heart rate monitoring consistency across subjects and types of exercise activities.

**[0016]** According to some embodiments of the present invention, a headset includes a base comprising an optical source and an optical detector, and a housing that is secured to the base and is configured to be positioned at or within an ear of a subject. The housing overlies the optical source and optical detector and includes a first light guide in optical communication with the optical source and a second light guide in optical communication with the optical detector. The first and second light guides define respective first and second axial directions that are outwardly diverging.

**[0017]** According to some embodiments of the present invention, an optical sensor module includes a base having an optical source and an optical detector, a housing secured to the base that overlies the optical source and optical detector, and at least one light polarizing element in optical communication with the optical source and the optical detector. The at least one polarizing element is configured to polarize light emitted by the optical source and/or polarize light detected by the optical detector.

**[0018]** In some embodiments, the at least one light polarizing element is a light polarizing film, a light polarizing lens, and/or a light polarizing light guiding material in the optical path of the optical source and/or the optical detector.

**[0019]** In some embodiments, the at least one light polarizing element includes a first light polarizing element in optical communication with the optical source and a second light polarizing element in optical communication with the optical detector. The first and second light polarizing elements may have the same light polarization orientation or may have respective different light polarization orientations.

**[0020]** In some embodiments, the sensor module housing includes at least one window through which light from the optical source passes and/or through which light detected by the optical detector passes. The at least one window includes the at least one polarizing element. For example, the at least one window may include a first window in optical communication with the optical source and a second window in optical communication with the optical detector. The first window includes a polarizing element (e.g., a polarizing film, etc.) and the second window includes a polarizing element (e.g., a polarizing film, etc.). The first and second window polarizing elements may have the same light polarization orientation or may have respective different light polarization orientations.

**[0021]** According to other embodiments of the present invention, an optical sensor module for detecting and/or measuring physiological information from a subject includes a base having an optical source and an optical detector, and a housing secured to the base that overlies the optical source and optical detector. The housing includes a

first light guide in optical communication with the optical source and a second light guide in optical communication with the optical detector. The first light guide includes light polarizing material that is configured to polarize light emitted by the optical source, and the second light guide includes light polarizing material that is configured to polarize light detected by the optical source. The first light guide light polarizing material and the second light guide light polarizing material may have the same light polarization orientation or may have respective different light polarization orientations.

**[0022]** According to other embodiments of the present invention, an optical sensor module for detecting and/or measuring physiological information from a subject includes a housing, an optical source supported by the housing, an optical detector supported by the housing, and at least one light polarizing element supported by the housing. The at least one light polarizing element is configured to polarize light emitted by the optical source and/or polarize light detected by the optical detector. In some embodiments, the at least one light polarizing element is a light polarizing film, a light polarizing lens, and/or a light polarizing light guiding material in the optical path of the optical source and/or the optical detector.

**[0023]** In some embodiments, the at least one light polarizing element includes a first light polarizing element in optical communication with the optical source and a second light polarizing element in optical communication with the optical detector. The first and second light polarizing elements may have the same light polarization orientation or may have respective different light polarization orientations.

**[0024]** In some embodiments, the sensor module housing includes at least one window through which light from the optical source passes and/or through which light detected by the optical detector passes. The at least one window includes the at least one polarizing element. For example, the at least one window may include a first window in optical communication with the optical source and a second window in optical communication with the optical detector. The first window includes a polarizing element (e.g., a polarizing film, etc.) and the second window includes a polarizing element (e.g., a polarizing film, etc.). The first and second window polarizing elements may have the same light polarization orientation or may have respective different light polarization orientations.

**[0025]** According to other embodiments of the present invention, an earbud includes a speaker driver, and a sensor module secured to the speaker driver that is configured to detect and/or measure physiological information from a subject wearing the earbud. In some embodiments, the sensor module includes a printed circuit board (PCB), an optical source secured to the PCB, and an optical detector secured to the PCB. In some embodiments, the PCB is an elongated, flexible PCB having a distal end portion, and the optical source and optical detector are secured to the PCB at the distal end portion.

**[0026]** In some embodiments, the earbud includes a first light guide coupled to the optical source and a second light guide coupled to the optical detector. The first light guide is configured to deliver light from the optical source into an ear region of the subject via a distal end thereof, and the second light guide is configured to collect light from the ear region via a distal end thereof and deliver collected light to the optical detector.

[0027] In some embodiments, the earbud includes one or more additional sensors secured to the speaker driver. Exemplary additional sensors include, but are not limited to, accelerometers, humidity sensors, altimeters, and temperature sensors.

[0028] In some embodiments, the earbud includes at least one signal processor configured to process signals produced by the optical detector. In other embodiments, the earbud is in communication with a data processing unit that is configured to process signals produced by the optical detector.

[0029] According to other embodiments of the present invention, a monitoring device includes a band capable of at least partially encircling a portion of a body of a subject, and an optical source and an optical detector supported by the band. The band includes a first light guide in optical communication with the optical source and a second light guide in optical communication with the optical detector. The first and second light guides define respective first and second axial directions, and the first and second axial directions diverge outwardly from the band. In some embodiments, the first and second light guides are angled relative to each other such that light rays emanating from the optical source and directed into the skin of the subject via the first light guide cannot overlap with light rays collected by the second light guide even when the housing is separated from the ear by a distance up to about three tenths of a centimeter (0.3 cm). In some embodiments, the first axial direction of the first light guide is angled relative to a plane defined by the optical source, and the second axial direction of the second light guide is angled relative to a plane defined by the optical detector.

[0030] It is noted that aspects of the invention described with respect to one embodiment may be incorporated in a different embodiment although not specifically described relative thereto. That is, all embodiments and/or features of any embodiment can be combined in any way and/or combination. Applicant reserves the right to change any originally filed claim or file any new claim accordingly, including the right to be able to amend any originally filed claim to depend from and/or incorporate any feature of any other claim although not originally claimed in that manner. These and other objects and/or aspects of the present invention are explained in detail below.

#### BRIEF DESCRIPTION OF THE DRAWINGS

[0031] The accompanying drawings, which form a part of the specification, illustrate various embodiments of the present invention. The drawings and description together serve to fully explain embodiments of the present invention.

[0032] FIG. 1 is a side section view of a conventional optical sensor illustrating how light can take a direct path from an optical source to an optical detector via reflection off of the skin of a subject wearing a device incorporating the optical sensor.

[0033] FIG. 2 is a side section view of an optical sensor module having light guides, according to some embodiments of the present invention.

[0034] FIG. 3A is an enlarged, partial view of the distal end of a light guide from the optical sensor module of FIG. 2 and which illustrates a curved configuration of the surface of the light guide distal end.

[0035] FIG. 3B is an enlarged, partial view of the distal end of a light guide from the optical sensor module of FIG.

2 and which illustrates a textured configuration of the surface of the light guide distal end and light rays emanating from the textured surface.

[0036] FIG. 4 is a side section view of an optical sensor module having multiple light guides, according to some embodiments of the present invention.

[0037] FIG. 5 is a graph illustrating the effect on an optical signal from a sensor module as a function of distance of the sensor module from the body of a subject wearing the sensor module.

[0038] FIG. 6 is a side section view of an optical sensor module having light guides, according to some embodiments of the present invention, and illustrating a light detector being moved in an arc above the optical source and a light source being moved in an arc above the optical detector.

[0039] FIG. 7 is a graph illustrating the results of a sweep test as illustrated in FIG. 6 for a sensor module without light guides, for a sensor module with light guides with flush, un-textured end surfaces, and for a sensor module with textured end surfaces.

[0040] FIG. 8 is a cross sectional view of a ring incorporating an optical sensor module according to some embodiments of the present invention.

[0041] FIG. 9A illustrates an optical sensor module integrated within a mobile device and that is configured to engage an optical module worn by a user, according to some embodiments of the present invention.

[0042] FIG. 9B is a side section view of the optical sensor and optical module of FIG. 9A prior to the optical sensor engaging the optical module.

[0043] FIGS. 10A-10B are side section views of an optical sensor module and an optical module, according to other embodiments of the present invention.

[0044] FIG. 11A is a side section view of an optical sensor module, an optical module, and an optical coupler therebetween, according to some embodiments of the present invention.

[0045] FIG. 11B is a side section view of an optical sensor module, an optical module, and an optical coupler therebetween, according to some embodiments of the present invention.

[0046] FIG. 12A is a front perspective view of an optical sensor module, according to some embodiments of the present invention.

[0047] FIG. 12B is a side view of the optical sensor module of FIG. 12A illustrating the light guides therein angled away from each other.

[0048] FIG. 12C is a side view of the optical sensor module of FIG. 12A.

[0049] FIG. 12D is a front view of the optical sensor module of FIG. 12A.

[0050] FIG. 12E is an end view of the optical sensor module of FIG. 12A.

[0051] FIG. 12F is a rear perspective view of the optical sensor module of FIG. 12A.

[0052] FIG. 13A is a front view of an earbud speaker driver with integrated optomechanics, according to some embodiments of the present invention.

[0053] FIG. 13B is a rear view of the earbud speaker driver of FIG. 13A.

[0054] FIG. 13C is a side view of the earbud speaker driver of FIG. 13A.

[0055] FIG. 13D is a rear view of the earbud speaker driver of FIG. 13A with the light guides coupled to a sensor module, according to some embodiments of the present invention.

[0056] FIG. 14 is an illustration of a human ear with various portions thereof labeled.

[0057] FIGS. 15-20 illustrate an earbud speaker driver positioned relative to an ear of a subject, according to various embodiments of the present invention.

[0058] FIGS. 21A-21B and 22A-22B illustrate a speaker driver sensor, according to some embodiments of the present invention.

[0059] FIGS. 23-25 are block diagrams illustrating various configurations of a data processing unit in communication with an earbud having a sensor module, according to embodiments of the present invention.

[0060] FIG. 26 is a block diagram an earbud having a sensor module and data processing capability, according to some embodiments of the present invention.

[0061] FIG. 27 illustrates a pair of earbuds which each contain a sensor module according to embodiments of the present invention, and which are in communication with a data processing unit.

[0062] FIG. 28 illustrates an earbud unit containing a sensor module and a data processing unit, according to some embodiments of the present invention.

[0063] FIGS. 29-31 illustrate a speaker driver sensor positioned within an ear of a subject, according to some embodiments of the present invention.

[0064] FIG. 32A is a side view of a biometric monitoring device, according to some embodiments of the present invention, and illustrating the center of gravity of the monitoring device.

[0065] FIG. 32B is a front view of the biometric monitoring device of FIG. 32A.

[0066] FIG. 32C is a front perspective view of the biometric monitoring device of FIG. 32A.

[0067] FIG. 32D is a front view of the biometric monitoring device of FIG. 32A illustrating the intersection of orthogonal planes along which the center of gravity of the monitoring device is located.

[0068] FIG. 32E is a side view of the biometric monitoring device of FIG. 32D.

[0069] FIG. 32F is a front perspective view of the biometric monitoring device of FIG. 32D.

[0070] FIG. 33 is a top perspective view side section view of an optical sensor module that includes at least one light polarizing element, according to some embodiments of the present invention.

[0071] FIG. 34 is a side section view of the optical sensor module of FIG. 33.

[0072] FIG. 35 is a side section view of an optical sensor module that includes at least one light polarizing element, according to some embodiments of the present invention.

#### DETAILED DESCRIPTION

[0073] The present invention will now be described more fully hereinafter with reference to the accompanying figures, in which embodiments of the invention are shown. This invention may, however, be embodied in many different forms and should not be construed as limited to the embodiments set forth herein. Like numbers refer to like elements throughout. In the figures, certain layers, components or features may be exaggerated for clarity, and broken lines

illustrate optional features or operations unless specified otherwise. In addition, the sequence of operations (or steps) is not limited to the order presented in the figures and/or claims unless specifically indicated otherwise. Features described with respect to one figure or embodiment can be associated with another embodiment or figure although not specifically described or shown as such.

[0074] It will be understood that when a feature or element is referred to as being “on” another feature or element, it can be directly on the other feature or element or intervening features and/or elements may also be present. In contrast, when a feature or element is referred to as being “directly on” another feature or element, there are no intervening features or elements present. It will also be understood that, when a feature or element is referred to as being “connected”, “attached”, “coupled”, or “secured” to another feature or element, it can be directly connected, attached, coupled, or secured to the other feature or element or intervening features or elements may be present. In contrast, when a feature or element is referred to as being “directly connected”, “directly attached”, “directly coupled”, or “directly secured” to another feature or element, there are no intervening features or elements present. Although described or shown with respect to one embodiment, the features and elements so described or shown can apply to other embodiments.

[0075] The terminology used herein is for the purpose of describing particular embodiments only and is not intended to be limiting of the invention. As used herein, the singular forms “a”, “an” and “the” are intended to include the plural forms as well, unless the context clearly indicates otherwise.

[0076] As used herein, the terms “comprise”, “comprising”, “comprises”, “include”, “including”, “includes”, “have”, “has”, “having”, or variants thereof are open-ended, and include one or more stated features, integers, elements, steps, components or functions but does not preclude the presence or addition of one or more other features, integers, elements, steps, components, functions or groups thereof. Furthermore, as used herein, the common abbreviation “e.g.,” which derives from the Latin phrase “*exempli gratia*,” may be used to introduce or specify a general example or examples of a previously mentioned item, and is not intended to be limiting of such item. The common abbreviation “i.e.,” which derives from the Latin phrase “*id est*,” may be used to specify a particular item from a more general recitation.

[0077] As used herein, the term “and/or” includes any and all combinations of one or more of the associated listed items and may be abbreviated as “/”.

[0078] As used herein, phrases such as “between X and Y” and “between about X and Y” should be interpreted to include X and Y. As used herein, phrases such as “between about X and Y” mean “between about X and about Y.” As used herein, phrases such as “from about X to Y” mean “from about X to about Y.”

[0079] Spatially relative terms, such as “under”, “below”, “lower”, “over”, “upper” and the like, may be used herein for ease of description to describe one element or feature’s relationship to another element(s) or feature(s) as illustrated in the figures. It will be understood that the spatially relative terms are intended to encompass different orientations of the device in use or operation in addition to the orientation depicted in the figures. For example, if a device in the figures is inverted, elements described as “under” or “beneath”

other elements or features would then be oriented “over” the other elements or features. Thus, the exemplary term “under” can encompass both an orientation of over and under. The device may be otherwise oriented (rotated 90 degrees or at other orientations) and the spatially relative descriptors used herein interpreted accordingly. Similarly, the terms “upwardly”, “downwardly”, “vertical”, “horizontal” and the like are used herein for the purpose of explanation only unless specifically indicated otherwise.

**[0080]** It will be understood that although the terms first and second are used herein to describe various features or elements, these features or elements should not be limited by these terms. These terms are only used to distinguish one feature or element from another feature or element. Thus, a first feature or element discussed below could be termed a second feature or element, and similarly, a second feature or element discussed below could be termed a first feature or element without departing from the teachings of the present invention.

**[0081]** Unless otherwise defined, all terms (including technical and scientific terms) used herein have the same meaning as commonly understood by one of ordinary skill in the art to which this invention belongs. It will be further understood that terms, such as those defined in commonly used dictionaries, should be interpreted as having a meaning that is consistent with their meaning in the context of the specification and relevant art and should not be interpreted in an idealized or overly formal sense unless expressly so defined herein. Well-known functions or constructions may not be described in detail for brevity and/or clarity.

**[0082]** The term “about”, as used herein with respect to a value or number, means that the value or number can vary, for example, by  $\pm 20\%$ ,  $\pm 10\%$ ,  $\pm 5\%$ ,  $\pm 1\%$ ,  $\pm 0.5\%$ , or even  $\pm 0.1\%$ .

**[0083]** The term “headset”, as used herein, is intended to include any type of device or earpiece that may be attached to or near the ear (or ears) of a user and may have various configurations, without limitation. Headsets incorporating optical sensor modules, as described herein, may include mono headsets (a device having only one earbud, one earpiece, etc.) and stereo headsets (a device having two earbuds, two earpieces, etc.), earbuds, hearing aids, ear jewelry, face masks, headbands, and the like. In some embodiments, the term “headset” may include broadly headset elements that are not located on the head but are associated with the headset. For example, in a “medallion” style wireless headset, where the medallion comprises the wireless electronics and the headphones are plugged into or hard-wired into the medallion, the wearable medallion would be considered part of the headset as a whole. Similarly, in some cases, if a mobile phone or other mobile device is intimately associated with a plugged-in headphone, then the term “headset” may refer to the headphone-mobile device combination.

**[0084]** The terms “optical source” and “optical emitter”, as used herein, are interchangeable.

**[0085]** The term “monitoring” refers to the act of measuring, quantifying, qualifying, estimating, sensing, calculating, interpolating, extrapolating, inferring, deducing, or any combination of these actions. More generally, “monitoring” refers to a way of getting information via one or more sensing elements. For example, “blood health monitoring” may include monitoring blood gas levels, blood hydration, and metabolite/electrolyte levels, etc.

**[0086]** The term “physiological” refers to matter or energy of or from the body of a creature (e.g., humans, animals, etc.). In embodiments of the present invention, the term “physiological” is intended to be used broadly, covering both physical and psychological matter and energy of or from the body of a creature. However, in some cases, the term “psychological” is called-out separately to emphasize aspects of physiology that are more closely tied to conscious or subconscious brain activity rather than the activity of other organs, tissues, or cells.

**[0087]** The term “body” refers to the body of a subject (human or animal) that may wear a device incorporating one or more optical sensor modules, according to embodiments of the present invention.

**[0088]** The term “coupling”, as used herein, refers to the interaction or communication between excitation light entering a region of a body and the region itself. For example, one form of optical coupling may be the interaction between excitation light generated from an optical sensor module and the blood vessels of the body of a user. In one embodiment, this interaction may involve excitation light entering the ear region and scattering from a blood vessel in the ear such that the intensity of scattered light is proportional to blood flow within the blood vessel.

**[0089]** The term “processor” is used broadly to refer to a signal processor or computing system or processing or computing method which may be localized or distributed. For example, a localized signal processor may comprise one or more signal processors or processing methods localized to a general location, such as to a wearable device. Examples of such wearable devices may comprise an earpiece, a headset, a headpiece, a finger clip/band, a toe clip/band, a limb band (such as an arm band or leg band), an ankle band, a wrist band, a nose band, a sensor patch, or the like. Examples of a distributed processor include “the cloud”, the internet, a remote database, a remote processor computer, a plurality of remote processors or computers in communication with each other, or the like, or processing methods distributed amongst one or more of these elements. The key difference is that a distributed processor may include delocalized elements, whereas a localized processor may work independently of a distributed processing system. As a specific example, microprocessors, microcontrollers, ASICs (application specific integrated circuits), analog processing circuitry, or digital signal processors are a few non-limiting examples of physical signal processors that may be found in wearable devices.

**[0090]** The term “remote” does not necessarily mean that a remote device is a wireless device or that it is a long distance away from a device in communication therewith. Rather, the term “remote” is intended to reference a device or system that is distinct from another device or system or that is not substantially reliant on another device or system for core functionality. For example, a computer wired to a wearable device may be considered a remote device, as the two devices are distinct and/or not substantially reliant on each other for core functionality. However, any wireless device (such as a portable device, for example) or system (such as a remote database for example) is considered remote to any other wireless device or system.

**[0091]** Sensor modules, according to embodiments of the present invention may be integrated into various wearable devices including, but not limited to headsets (e.g., earbuds, etc.), wristbands, arm bands, leg bands, rings, patches, etc.

[0092] Referring to FIG. 2, an optical sensor module 20 that may be incorporated into a wearable device according to some embodiments of the present invention is illustrated. The illustrated sensor module 20 includes a substrate or base 22 (e.g., a circuit board, etc.) having an optical source 24 and an optical detector 26. As would be understood by one skilled in the art of the present invention, the base 22 may support and/or be connected to various electronic components including, but not limited to, a signal processor, a wireless module for communicating with a remote device, a memory storage device, etc. Moreover, a battery, such as a lithium polymer battery or other portable battery, may be mounted to or connected to the base 22 and may be charged via a charge port, such as a USB charge port, for example. Additionally, the base 22 may be flexible, may be rigid, or may include a combination of flexible and rigid material. The base 22 may have various configurations suitable for supporting electronics.

[0093] The optical source 24 may be one or more light-emitting diodes (LED), laser diodes (LD), compact incandescent bulbs, micro-plasma emitters, IR blackbody sources, organic LEDs, or the like. The optical detector 26 may be one or more photodiodes, photodetectors, phototransistors, thyristors, solid state devices, optical chipsets, or the like.

[0094] A housing 30 is secured to the base 22 and overlies the optical source 24 and optical detector 26. The illustrated housing 30 has a curved outer surface 32 that is configured to engage a particular portion of the body of a user of the sensor module 20 (i.e., a person wearing a device incorporating the optical sensor module 20). For example, in some embodiments, the sensor module 20 may be incorporated into an earbud and the housing outer surface 32 is contoured to matingly engage a particular region of the ear (e.g., the region between the anti-tragus and the concha, the region along the helix or anti-helix of the ear, etc., as illustrated in FIG. 14). However, the housing outer surface 32 may have various shapes and configurations and need not be curved. For example, in some embodiments, the outer surface 32 of the housing may be flat such that the sensor module 20 may be integrated within a wristband.

[0095] The term “matingly engage”, as used herein, does not necessarily mean that the housing 30 must physically touch the body of the person; rather, “matingly engage” implies that the housing 30 is designed to optically or optomechanically couple with a particular region of the body or to have a physical structure that compliments a particular region of the body. For example, the housing 30 of FIG. 2 may fit well within an audio earbud and support optical coupling between the anti-tragus and concha of the ear, but a flat housing structure may be more suitable for the housing enabling optical coupling to a person’s wrist.

[0096] Though FIG. 2 presents a convex (outward-curving) housing 30, a concave (inward-curving) housing 30 may be better suited for other regions of the body. For example, a concave housing 30 may be well-suited for a digit or limb of the body. Additionally, a concave housing 30 may be well-suited for coupling to the ear region behind the ear, adjacent to the earlobe.

[0097] The illustrated housing 30 includes a first light guide 40 in optical communication with the optical source 24 and a second light guide 42 in optical communication with the optical detector 26. In addition to supporting the first and second light guides 40, 42, the housing 30 may be configured to enclose and protect the various electronic

components mounted to the base 22 from ambient interference (air, humidity, particulates, electromagnetic interference, etc). In some embodiments, the housing 30 may comprise opaque material that prevents light from escaping or entering the light guides 40, 42 laterally (i.e., confines light within the light guides 40, 42 such that light only enters and exits through the respective light guide ends). However, embodiments of the present invention do not require the housing to comprise opaque material.

[0098] The first light guide 40 comprises light transmissive material configured to deliver light from the optical source 24 into a region of a body of a user at one or more predetermined locations. The second light guide 40 comprises light transmissive material configured to collect light external to the sensor module 20 and deliver the collected light to the optical detector 26. The first and second light guides 40, 42 may be formed from various types of light transmissive material. In some embodiments, one or both of the first and second light guides 40, 42 may be formed from an elastomeric light transmissive material. In other embodiments, one or both of the first and second light guides 40, 42 may be formed from a substantially rigid light transmissive material. In some embodiments, one or both of the first and second light guides 40, 42 may be formed from a combination of elastomeric light transmissive material and substantially rigid light transmissive material. Exemplary light transmissive materials include, but are not limited to, polycarbonate, acrylic, silicone, glass, metal oxides, polyurethane, etc. In addition, one or both of the first and second light guides 40, 42 may comprise one or more optical fibers.

[0099] In some embodiments, a physical optical filter may be disposed along the optical paths  $R_o$  and  $R_i$  such that only certain wavelengths of light are allowed to leave or enter the sensor module 20. The physical optical filter can be disposed anywhere along the optical path(s), and may be any variety of filters that are well known in the art, as well as new, innovative filters. An optical filter may be composed of polycarbonate, acrylic, silicone, glass, metal oxides, polyurethane, etc. In some embodiments, an optical filter may be a small slab that is placed in the optical path of the optical source 24 and/or optical detector 26 and may be supported by the structure of the sensor module 20. In some embodiments, an optical filter may be integrated with the optical source 24 and/or the optical detector 26. For example, a bandpass filter, such as an interference filter or the like, may be disposed on the top of the optical source 24 and/or optical detector 26. Alternatively (or additionally), an optical filter effect may be integrated within the semiconductor material comprising the optical source 24 and/or optical detector 26, such as by selective ion implantation of certain regions within silicon or by band-gap engineering within compound semiconductors, such as the AlInGaAs or AlInGaN system of semiconductor engineering.

[0100] In some embodiments, an optical filter may be integrated within one or more of the light guides 40 and 42. For example, one or both of the first and second light guides 40, 42 may comprise a material having an optically filtering dye or a material which inherently filters one or more wavelengths of light. As one example, either or both of the light guides 40 and 42 may comprise, wholly or partially, a dye therewithin. As one specific example, at least one light guide may comprise a dye, such as an infrared dye designed to block visible wavelengths but pass IR wavelengths. For example, a polycarbonate or acrylic light guide 40 or 42,

dyed with Gentex-E800, would facilitate both light-guiding and IR-pass filtering functionality. Alternatively, another example of such an integrated physical optical filter comprises Filtron® absorptive dyes dispersed in polycarbonate and/or acrylic to create an edge or long-pass optical filter. Such materials may be conventionally molded, extruded, and/or fabricated into an optical filter having a variety of shapes. In the case of FIG. 2, at least one light guide may be partially or wholly comprised of such a material, thereby facilitating the combinational purpose of light guiding and optical filtering.

[0101] A few additional non-limiting examples of an inherently filtering material includes sapphire, which absorbs some infrared (IR) wavelengths, and glass, which absorbs some ultraviolet (UV) wavelengths. However, various types of filtering material may be utilized, without limitation. In some embodiments, one or both of the light guides 40, 42 may be surrounded or partially surrounded by a cladding/barrier material (not shown) that is configured to at least partially block light from an external source from entering one or both of the light guides 40, 42 at select locations along the light guides 40, 42 and/or at least partially confine light within one or both light guides 40, 42. The cladding/barrier material may be a light blocking material and/or a light reflective material and/or a material that has a higher optical scattering coefficient than the light guiding material of the light guides 40, 42. For example, the cladding material may be a dark (e.g., black, etc.) or silver (or other reflective color) coating, a material with refractive index that differs from the core light guide material, or a texturized light-scattering material on one or more portions of a distal end surface 40c, 42c of one or both of the light guides 40, 42.

[0102] The first light guide 40 defines a first axial direction  $A_1$ , and the second light guide 42 defines a second axial direction  $A_2$ , as illustrated in FIG. 2. The first axial direction  $A_1$  of the first light guide 40 has an angle  $a_1$  relative to a plane  $P_1$  defined by a surface of the optical source 24 that is less than ninety degrees ( $90^\circ$ ), and the second axial direction  $A_2$  of the second light guide 42 has an angle  $a_2$  relative to a plane  $P_2$  defined by a surface of the optical detector 26 that is less than ninety degrees ( $90^\circ$ ). As such, the first and second light guides 40, 42 are positioned within the housing 30 such that they diverge outwardly from the housing 30.

[0103] In some embodiments of the present invention, one or both of the first and second light guides 40, 42 may have a generally cylindrical configuration. In other embodiments, one or both of the first and second light guides 40, 42 may have a generally non-cylindrical configuration, e.g., rectangular, triangular, oval, etc.

[0104] Each of the first and second light guides 40, 42 has a respective proximal end 40a, 42a and an opposite distal end 40b, 42b. The proximal end 40a of the first light guide 40 is positioned adjacent the optical source 24, and the proximal end 42a of the second light guide 42 is positioned adjacent the optical detector 26. In the illustrated embodiment, the distal end 40b, 42b of the light guides 40, 42 extends slightly outwardly from the housing 30. However, in other embodiments of the present invention, the distal end portion 40b, 42b of one or both light guides 40, 42 may be substantially flush with the housing 30 or may even be recessed within the housing 30.

[0105] Light guides that extend from the housing 30 (as opposed to light guides that are flush with the housing 30)

may facilitate a higher signal-to-noise (S/N) ratio for biometrically modulated light vs. unwanted optical scatter, because extended light guides may capture more of the desired biometric signal and/or may reject more of the unwanted noise. Namely, in PPG, blood flowing through a blood vessel will cause optical scatter directly or indirectly related to blood flow changes. However, there will also be unwanted optical scatter associated with light bouncing off (i.e., reflecting off) the skin and other body tissues in a manner that is not biometrically modulated (i.e., light that is not interacting with blood flow changes). The desired signal “S” is comprised of light that is biometrically modulated and the noise “N” is comprised of all other scattered light (such as light scattered by skin, other body tissues, motion artifacts, environmental artifacts, etc.). As will be described later, the shape and angle of the light guides may help increase the S/N ratio.

[0106] Light guides that are flush with the housing 30 (as opposed to light guides that are extended from the housing 30) may be more aesthetically appealing to those wearing an earbud, armband, or other wearable device form-factor that integrates the sensor module 20. This is because there will be no substantial protrusions that would make the wearable device look much different than a wearable device that does not integrate such a sensor module. Moreover, there may be a higher degree of wearability and comfort associated with flush light guides if there are no protrusions that may potentially generate discomfort after a period of time wearing a device incorporating the sensor module 20.

[0107] The distal end 40b, 42b of each illustrated light guide 40, 42 has a respective exposed end surface 40c, 42c that is configured to engage (or be positioned adjacent or near) a portion of the body B of a user. In some embodiments, the end surface 40c, 42c of one or both of the light guides 40, 42 may have a curved configuration. For example, FIG. 3A illustrates a rounded end surface 40c of the first light guide 40 of the sensor module 20 of FIG. 2. In other embodiments, the end surface 40c, 42c of one or both of the light guides 40, 42 may have a flat configuration. However, the end surface 40c, 42c of one or both of the light guides 40, 42 may be shaped in a variety of ways to couple light to and from the body of a user. For example, a rounded surface may improve light collection from a wider angle and a flat surface may narrow the field of view of the light guide. In some cases, a wider field of view may be important to measure more light from a broader range along the body, but in other cases, a narrower view may be important to focus the field of view on a specific region of the body. Note that the bottom 40d of the light guide 40 of FIG. 3A is at an angle with respect to the top 40c of the light guide 40. Although only light guide 40 is illustrated in FIG. 3A, it is understood that the other light guide 42 may have a bottom portion that is at an angle with respect to a top portion thereof. This alteration of symmetry may provide better coupling of light from/to the optical source 24/optical detector 26 to/from the respective light guide 40, 42 while simultaneously directing the respective light paths at the angles  $a_1$  and  $a_2$  (FIG. 2).

[0108] In some embodiments, the end surface 40c, 42c of one or both of the light guides 40, 42 may be textured with a non-optically smooth finish such as an SPI (Society of Plastics Industry) B-1 finish, or the like. However, other finish texturing may be used in accordance with embodiments of the present invention including, but not limited to, SPI A-1, SPI A-2, SPI A-3, SPI B-2, and SPI B-3. However,

embodiments of the present invention do not require surface texturing of the end surfaces 40c, 42c.

[0109] FIG. 3B illustrates the optical impact of a textured end surface 40c of the light guide 40 of the sensor module 20 of FIG. 2. A textured surface can cause a “feathering” or “diffusing” of light from the optical source 24, thereby limiting the light that reflects directly from the tissue and into the optical detector 26. A diffuse optical beam may also be more uniform than a beam of light generated by the optical source 24. Diffused light beams may have an intensity distribution that is less sensitive to body motion and may be useful in alleviating motion artifacts in scattered light coming from the body and detected by the optical detector 26. The texturing features in this particular example of FIG. 3B were generated with an average texturing feature size smaller than about 100  $\mu\text{m}$ , and the diameter of the light guide was about 3 mm.

[0110] The angled configuration of the first and second light guides 40, 42 prevents most or all light from the optical source 24 from directly reaching the optical detector 26 (i.e., without passing through a portion of the body of a user first) when the outer surface 32 of the housing 30 is separated from the body of a user, for example, by a distance up to about three tenths of a centimeter (0.3 cm) or more. This is illustrated in FIG. 2 wherein the dotted line B is representative of the body (i.e., the skin) of a user. Distance  $D_1$  represents the distance from the body B to the outer surface 32 of the housing 30. Rays of light emanating from the optical source are represented by  $R_o$  and rays of light detected by the optical detector are represented by  $R_i$ . The light rays  $R_o$  emanating from the optical source 24 do not overlap with the light rays  $R_i$  returning to the optical detector 26 over the distance  $D_1$ , as represented by distance  $D_2$ . As such, the light emanating from the optical source 24 is directed along the most physiologically meaningful signal pathway (i.e., through the body B and without substantial, unwanted reflection from the body B into the optical detector 26).

[0111] Referring to FIG. 4, a sensor module 20, according to some embodiments of the present invention, may include multiple optical sources 24 and/or multiple optical detectors 26 and, as such, multiple light guides 40, 42 may be utilized. In the illustrated embodiment of FIG. 4, a respective light guide 40 is in optical communication with each of the two optical sources 24, and a respective light guide 42 is in optical communication with each of the two optical detectors 26. The light guides 40, 42 each have respective axial directions  $A_1, A_2$  that diverge outwardly, as discussed above with respect to FIG. 2. Although FIG. 4 shows light guide arrays are aligned in line with respect to each other, it should be understood that the arrays of light guides may be distributed across a common plane or even in multiple planes, and a linear array is not required for embodiments of the present invention.

[0112] FIG. 5 illustrates how effective a sensor module, such as the sensor module 20 of FIG. 2, may be in reducing the effect of noise as a result of movement of the sensor module 20 relative to the body B of a user. The separation distance between sensor module housing outer surface 32 and the body of a user B is represented by  $D_1$  in FIG. 2, and is plotted along the “X” axis of FIG. 5. The signal detected by the optical detector 26 is plotted along the “Y” axis of FIG. 5 and varies with the distance  $D_1$ . The signal is shown in FIG. 5 based on this separation distance (Sensor-tissue

separation distance, mm). When a conventional sensor module with no light guides is used, the signal onset with small separation distances is abrupt (namely, the slope is higher), leading to a substantial amount of motion artifact noise in the physiological signal (represented by curve 50). When the sensor module 20 of FIG. 2 is used with flush, non-textured light guides 40, 42, the signal onset with separation is much less abrupt (namely, the slope is lower), as illustrated by curve 52. When the sensor module 20 of FIG. 2 is used with light guides 40, 42 having respective end surfaces 40c, 42c that are textured, the signal onset with sensor-tissue separation is very slow (namely, the slope is lowest), leading to much less physiological movement-associated noise, as illustrated by curve 54. FIG. 5 illustrates the robustness of the sensor module 20 of FIG. 2 against noise in a physiological signal detected by the optical detector 26. Thus, although it is true that curve 50 shows a higher overall signal than that of curve 52 and 54, the slope of curve 50 is much higher as the sensor module separates from the skin of the user, showing that the use of light guides can reduce motion artifacts. Furthermore, generally speaking, a higher S/N as well as lower motion artifact sensitivity will result in the best performing PPG sensor modules.

[0113] Referring to FIG. 6, another way to model the robustness of the sensor module 20 of FIG. 2 against physiological signal noise is to perform a “sweep test”. The sweep test involves sweeping either a light source 60 over the optical detector 26 or sweeping an optical detector 62 over the optical source 24. The response signal(s) of the optical detector 24 as a function of the angle of the light source 60 is recorded and the response of the optical detector 62 as a function of the angle of the optical detector 62 is recorded.

[0114] The result of such a sweep test is illustrated in FIG. 7 for a sensor module without light guides, for a sensor module, such as sensor module 20 (FIG. 2) with light guides with flush, un-textured end surfaces 40c, 42c, and for a sensor module, such as sensor module 20 (FIG. 2) with textured end surfaces 40c, 42c. In FIG. 7, sweep angle in degrees is plotted along the “X” axis, and signal response is plotted along the “Y” axis. In FIG. 7, zero degrees ( $0^\circ$ ) represents a direction normal (“normal direction”) to the planes  $P_1, P_2$  of the surfaces of the optical source 24 and the optical detector 26. Similarly, thirty degrees ( $30^\circ$ ) in FIG. 7 represents an angle that is  $30^\circ$  between the “normal direction” and the emission angle of the light source used for the sweep test. As can be seen with the recorded signal vs. sweep angle, the signal has a much gentler onset with sweep towards the normal (i.e.,  $0^\circ$ ) with light guides (in this case the light guides may be referred to as “light pipes”) 40, 42 having textured end surfaces 40c, 42c, as represented by curve 70, and with light guides 40, 42 with flush, un-textured end surfaces 40c, 42c, as represented by curve 74. Within the angle of interest, which are the angles of about  $\pm 30^\circ$ , the signal onset is much steeper without the use of light guides, as represented by curve 72. This steep onset in signal is a source of motion-artifact noise that can be remedied by the use of light guides, according to embodiments of the present invention. Note that in FIG. 7 the total overall signal is highest without light guides, but because the change in signal with angle is so high, the ultimate S/N ratio favors using light guides. This is because the noise ( $N_m$ ) resulting from motion artifacts can be many times that of the PPG signal associated with biometrically modulated light.

[0115] FIG. 8 illustrates an embodiment of the sensor module 20 of FIG. 2 incorporated into a ring device 80 that is configured to be worn around a digit of a user, according to some embodiments of the present invention. The light guides 40, 42 of the sensor module 20 are angled away from each other to prevent the overlap of light rays leaving the optical source 24 from directly entering the optical detector 26. A battery (e.g., a flexible battery) 84 is located within the band 82 of the ring device 80 to provide electrical power to the sensor module 20.

[0116] It should be noted that the sensor module 20 may be integrated into the ring device 80 in additional ways in accordance with embodiments of the present invention. For example, the sensor module 20 may be partially within the ring device 80 rather than wholly within the ring device 80 as shown in FIG. 8. Additionally, the light guides 40, 42 may extend or partially extend the length of the outer-inner diameter length (the length that is the difference between the outer and inner diameter of the ring device 80) or the light guides 40, 42 may protrude from the ring device 80 itself. Additional configurations may be used where the light guides 40, 42 direct light at angles relative to each other (e.g., angles  $a_1$  and  $a_2$  illustrated in FIG. 2). Also, it should be noted that the ring device 80 may be used for not only a finger ring but for any appendage or rounded form-factor, such as a digit or limb, such as a toe, arm, wrist, leg, a neck, a waist, and the like. The strap or band 82 may have different sizes and/or shapes depending on the location of donning (i.e., the location on the body of a subject where the device 80 is worn).

[0117] Referring to FIGS. 9A-9B, 10A-10B, and 11A-11B, embodiments of the present invention utilizing a smartphone 100 or other mobile or electrical device are illustrated. The illustrated smartphone 100 includes an optical sensor module 110 that is in proximity to, or integrated within, the camera optics of the smartphone 100 or another optical emitter/detector already on the smartphone 100. The optical sensor module 110 is coupled to an optical module 120 in a wearable structure 130 (such as an armband, wristband, leg band, ring, etc.). This embodiment can be useful for the case when electronics are not desired to be within the wearable structure itself—for example, optical module 120 may be optics within a phone armband strap, where the smartphone 100 may contain all the electronics but may not have the optomechanics for biometric monitoring itself. The optical sensor module 110 may have light guides within it or it may not. For example, as illustrated in FIG. 9B, the optical module 110' includes only a single window W with perhaps a barrier 112 between the optical source 24 and the optical detector 26. The barrier 112 may protrude all the way to the surface of the window W or it may be shorter. The benefit of having the barrier 112 protrude to the surface of the window W is that doing so may reduce or eliminate cross-talk between the optical source 24 and optical detector 26.

[0118] The illustrated optical modules 110, 120, 140 include light guides 40, 42 as described above with respect to the sensor module 20 of FIG. 2. When the optical modules 110 and 120 (and 140, when utilized) are in alignment (as expressed by the dotted lines in FIG. 9A), light (e.g., from the flash associated with the camera of the smartphone 100) can be coupled from the smartphone 100 to the body of the person and back from the body to the smartphone 100, such that stable optical monitoring of the body can be achieved. The light guides 40, 42 in the optical module 120 may be

configured to be adjacent or proximate to the skin of a user and may be angled away from each other to prevent the overlap of light rays leaving the optical sources 24 and directly entering the optical detectors 26, as described above.

[0119] In the embodiment illustrated in FIGS. 10A-10B, the optical module 120 has multiple light guides 40, 42 that align with a respective multiple light guides 40, 42 of the sensor module 110. The light guides 40, 42 of the sensor module 110 are substantially orthogonal to the respective optical emitters 24 and optical detectors 26, as illustrated. However, the light guides 40, 42 of the optical module 120 are angled such that they diverge from each other, as illustrated. This angled configuration of the light guides 40, 42 in the optical module 120 prevents most or all light from the optical sources 24 from directly reaching the optical detectors 26 without first passing through a portion of the body of a user.

[0120] Other coupling configurations and light-guiding configurations for the optical module 120 may be used in embodiments of the present invention, and the light guides of the module 120 do not need to be angled as shown in FIGS. 10A-10B. However, the benefits of angling have been disclosed herein. Additionally, the light guides 40, 42 may be cylindrical, oval, or elliptical (i.e., have circular, oval, or elliptical cross-sections) to prevent unwanted scattering at the edges. However, having light-guiding cross-sections with “sides” or “angles”, such as the case for polygonal light guide cross-sections, may be useful for matching the coupling between the modules 110 and 120.

[0121] A benefit of the configuration presented in FIG. 9A is that the optical module 120 may reside in a wearable band (or apparel item) 130 without any need for supporting electronics or battery power in the wearable band 130, as the optical emission and detection may take place via the electronics/optics of the electrical device 100 (such as a smartphone, smartwatch, smartearbud, smartsensor, or other electrical apparatus that is light-weight enough to be attached to and worn on the body of a person). The wearable band 130 may be a ring, an armband (as shown), wristband, legband, neckband, or any band or apparel item such as an item of clothing (shirts, socks, under-garments, etc.) that can be worn along the body but which can also support the optical module 120. Many different kinds of band materials and fabrics may be used, such as plastic, polymers, metals, rubbers, silicones, cotton, nylon, wood, or any other sturdy materials that can be worn for a period of time by subjects. However, the wearable band 130 should be stabilized along the body for accurate physiological readings to be assessed on a continuous basis. This may be achieved by using a stretchable material that can fit firmly along the body and/or by integrating a securing mechanism such as a buckle, clamp, clasp, button, etc., and/or by employing a springing or clamping method to hold both modules in place along the body, using one or more body regions for mechanical support. The optical module 120 does not need to touch the skin in order to generate physiological information, but the optical module 120 typically will perform best when stabilized with respect to the body of the subject.

[0122] An additional benefit of the configuration shown in FIG. 9A is that the configuration allows for novel biometric sensing use cases via selective biometric analysis. Namely, if the electrical device 100 is configured to have optics 110 that comprises both a camera module (such as smartphone

CCD camera optics, for example) as well as PPG module (such as an optical emitter and an accompanied optical detector), and a processor communicating with both the camera module and the PPG module, then advanced biometric sensing may be achieved, such as selective biometric analysis. In this methodology, images of the body of the subject may be collected and analyzed by the processor with respect to blood flow as sensed by the PPG module. For example, the processor may identify the frequency of blood flow (i.e., the frequency relating to the heart rate or breathing rate) via sensor data from the PPG module and may analyze images sensed by the camera module with respect to this frequency. In this method, pixels that are changing at the same rate (or approximate same rate) as the blood flow frequency may be selectively amplified with respect to pixels that are not changing at this rate (raising the effective contrast). In this way, blood vessels (arteries, veins, arterioles, capillaries, and the like) may be selectively analyzed to generate biometric assessments, even in noisy environments.

**[0123]** According to some embodiments of the present invention, the process can be executed in reverse such that regions of the body that do not substantially modulate with blood flow may be selectively amplified with respect to regions that do modulate with blood flow. These more static regions (such as certain tissue regions comprising bone, skin, tendons, etc.) may then be selectively analyzed.

**[0124]** The above-described selective amplification may be further enhanced by incorporating active motion-artifact removal by using a motion sensor (such as an accelerometer or other motion sensor) in physical communication with the body, smart device **100**, and/or wearable band as a noise reference such that the processor, in communication with the motion sensor, is able to selectively remove or attenuate frequencies associated with body motion or other unwanted motion noise. Because many smartphones and other smart devices may comprise both digital cameras and accelerometers (often having multiple axes), the processor (which may also reside in a smartphone) may have access to all of these electronics.

**[0125]** There are several examples of biometric assessments that may be generated by the selective amplification method described above. For example, by ratioing intensities of two (2) or more wavelengths from the selectively amplified pixels, an assessment of blood analyte along each blood vessel may be generated. An example of such blood analyte may include any optically interacting blood analyte, such as blood hemoglobin (oxyhemoglobin, deoxyhemoglobin, carboxyhemoglobin, and methemoglobin, for example), bilirubin, lactate, glucose, and the like. Numerous blood chromophores may be analyzed via this method. In the case of glucose and other blood analyte which are not chromophores, adding one or more polarizers to the optics (**110**, **120**) may be required, as glucose and other blood constituents have been observed to preferentially scatter light at certain polarizations. As yet another example of a biometric assessment using selective amplification, a processor may analyze blood vessels along their pathways to see how they change shape with each pulse. This assessment may be used to assess vascular compliance and/or blood pressure along the vessels or to assess cardiac output by assessing these localized blood vessel changes in relation to a physical model. As yet another example of a biometric assessment using selective amplification, a processor may characterize

static (not time-varying) and/or dynamic (time-varying) changes in blood vessels to generate a biometric identification of a subject. In this assessment, a processor may compare the blood vessel characterization with a known characterization stored in memory, for example, by running an algorithm to assess their similarity. A similarity above a certain threshold may then trigger an identification for a subject. It is important to note that a key aspect of embodiments of the present invention is that combining a PPG sensor with a camera affords the ability to generate a contrast between physiological properties/characteristics that modulate with blood flow and other properties/characteristics that do not substantially modulate with blood flow.

**[0126]** This selective amplification method may be executed with or without modulating the PPG sensor light source (the optical emitter) or with or without polling the PPG detector and/or the camera. For example, a PPG sensor may be operating in a continuous mode, and PPG readings as well as camera readings may be collected continuously. Alternatively, a PPG sensor may be pulsed to generate pulses of light, or the PPG detector or the camera readings may be polled at time intervals. If multiple wavelengths are employed with the PPG sensor, then alternately modulating (i.e., pulsing) the optical emitters such that only one emitter is on at a time may help differentiate the PPG signals for each wavelength. However, this effect may also be achieved by continuously emitting all optical emitting wavelengths and differentiating signals from each wavelength via optical filters on the camera and/or the optical detector(s) of a PPG sensor. For example, the optical detectors of a PPG sensor may each comprise one or more optical filters to pass only certain wavelengths of light and the camera may comprise optical filters and/or may comprise beam-splitting optics to direct certain optical wavelength ranges to certain light-detecting regions of the camera.

**[0127]** In some embodiments, an optomechanical coupler **140** (FIGS. **9A** and **11A-11B**) can be used to interface between optical sensor module **110** and optical module **120** such that the two optical modules **110**, **120** can be matched or to provide additional stability between the smartphone optical module **110** and the band optical module **120**. This may be advantageous where a smartphone **100** has native optomechanics **110** (such as the optics used for a photographic camera and/or optics used to measure heart rate) that may not directly match with the optomechanics of the band **120**. In this case, the coupling optomechanics **140** can be used to translate between the optics **110** and **120**.

**[0128]** In the embodiment illustrated in FIG. **11A**, the optomechanical coupler **140** has light guides **40**, **42** with a similar shape and configuration as the sensor module **110**. In the embodiment illustrated in FIG. **11B**, the coupler **140** has light guides **40**, **42** with shapes at one end that conform with shapes of the light guides **40**, **42** of the sensor module **110**, and with different shapes at the opposite end that conform with shapes of the light guides **40**, **42** of the optical module **120**. The coupler **140** is designed to couple with the optics on a smart device (illustrated as a smartphone **100** in FIG. **9A**) and the optics in the wearable sensor (**130**, FIG. **9A**). As such, a user can utilize a separate coupler **140** for each smartphone or other device that they use, since each smartphone/device may be manufactured using different optics.

**[0129]** FIGS. **12A-12F** illustrate another style of the optical sensor module **20** of FIG. **2** that can be used with various wearable monitoring devices, such as earbud monitoring

devices. The illustrated sensor module 20 includes a substrate or base 22 (e.g., a circuit board, etc.) having an optical source 24 and an optical detector 26 on one side 22a thereof. The base 22 may support and/or be connected to various electronic components including, but not limited to, a signal processor, a wireless module for communicating with a remote device, a memory storage device, etc. Moreover, a battery, such as a lithium polymer battery or other portable battery, may be mounted to or connected to the base 22 and may be charged via a charge port, such as a USB charge port for example. Additionally, the base 22 may be flexible, rigid, or a combination of flexible and rigid material, or various other base constructs suitable for supporting electronics. The base 22 may comprise one piece or a plurality of pieces. In the illustrated embodiment, a capacitor 24c for driving the optical source 24 and an accelerometer 27 are mounted to an opposite side 22b of the base 22.

[0130] The optical source 24 may be one or more light-emitting diodes (LED), laser diodes (LD), compact incandescent bulbs, micro-plasma emitters, IR blackbody sources, or the like. The optical detector 26 may be one or more photodiodes, photodetectors, phototransistors, thyristors, solid state devices, optical chipsets, or the like.

[0131] A housing 30 is secured to the base 22 and overlies the optical source 24 and optical detector 26. The illustrated housing 30 has a curved outer surface 32 that is configured to engage a particular portion of the body of a user wearing a device incorporating the sensor module 20. For example, although the sensor module 20 may be integrated into numerous wearable form-factors that afford proximate location of the sensor module to the skin of the user, in some embodiments, the sensor module 20 may be incorporated into an earbud and the housing outer surface 32 is contoured to matingly engage a particular region of the ear (e.g., the region between the anti-tragus and the concha, the region along the helix or anti-helix of the ear etc.). However, the housing outer surface 32 may have various shapes and configurations and need not be curved. For example, a wristband module applying the invention may have a flat housing outer surface 32.

[0132] The housing 30 includes a first light guide 40 in optical communication with the optical source 24 and a second light guide 42 in optical communication with the optical detector 26. In addition to supporting the first and second light guides 40, 42, the housing 30 may be configured to enclose and protect the various electronic components mounted to the base 22 from ambient interference (air, humidity, particulates, electromagnetic interference, etc.).

[0133] The first light guide 40 defines a first axial direction  $A_1$ , and the second light guide 42 defines a second axial direction  $A_2$ . The first axial direction  $A_1$  of the first light guide 40 has an angle  $a_1$  relative to a plane  $P_1$  defined by a surface of the optical source 24 that is less than ninety degrees ( $90^\circ$ ), and the second axial direction  $A_2$  of the second light guide 42 has an angle  $a_2$  relative to a plane  $P_2$  defined by a surface of the optical detector 26 that is less than ninety degrees ( $90^\circ$ ). As such, the first and second light guides 40, 42 are positioned within the housing 30 such that they diverge outwardly from the housing 30.

[0134] Referring now to FIGS. 13A-13D, an earbud speaker driver 300 with integrated optomechanics, according to some embodiments of the present invention, is illustrated. The speaker driver 300 has opposite front and rear portions 302a, 302b. As understood by those skilled in the

art, sound is emitted through apertures 306 formed in the front portion 302a of the speaker driver 300. An optical source 24 and optical detector 26 are supported by a printed circuit board (PCB) 304 on the rear portion 302b of the speaker driver 300. Light guides 40, 42 couple from the optical source 24 and optical detector 26 to a select region of the ear. In one particular embodiment, the light guides lead to a sensor module that may be placed between the anti-tragus and concha of the ear, such as the sensor module 304 in FIG. 13D. The light guides 40, 42 may lead to any region of the ear, such as the ear canal, tympanic membrane, earlobe, helix, anti-helix, tragus, behind the ear, temple, etc.

[0135] A key benefit of the illustrated speaker driver 300 of FIGS. 13A-13D is that all the sensor electronics may be integrated into a compact speaker driver or speaker driver assembly, rather than dispersed throughout an earbud, and the light guiding may be used to couple from the speaker driver 300 to numerous locations of the ear. Additional sensor electronics and light guiding may also be located on the speaker driver 300. For example, the PCB 304 may support an accelerometer, humidity sensor, altimeter, proximity sensor, temperature sensor, etc. Moreover, the PCB 304 may house a temperature sensor coupled to a light guide that directs black body radiation from the tympanic membrane to the temperature sensor. In this case, the temperature sensor may preferably comprise at least one thermopile and one thermistor.

[0136] FIG. 14 is an illustration of a human ear E with various portions thereof labeled. FIGS. 15-17, 18A-18B, 19, 20, 21A-21B and 22A-22B show various embodiments of speaker drivers 300 integrated with biometric sensors or both biometric sensors and light guides. It should be noted that the speaker drivers 300 may be integrated within earbuds or other earpieces, or other headwear, but the earbuds are not shown to promote clarity of the invention and to highlight the fact that the speaker drivers 300 may be integrated into a variety of different earbuds, earpieces, headwear, and the like. Additionally, the sizes of various elements may not be to scale. For example, light guides (e.g., 40, 42, FIGS. 17, 19) may be shown smaller, larger, differently shaped than may be in an actual device in order to help present certain aspects of the invention more clearly in the figures.

[0137] In FIGS. 15-20, a speaker driver 300 is shown without an earbud housing, as the speaker driver 300 may be incorporated in a variety of earbud designs. The speaker driver 300 is shown positioned within an ear E of a subject and has a sensor circuit 312. In the embodiment illustrated in FIG. 15, the speaker driver 300 is positioned near the concha of the ear E, for example between the antihelix and the tragus of the ear E. A flex circuit (or other electrical connection medium) 310 is electrically connected to the speaker driver 300 and extends from the speaker driver 300. The flex circuit 310 supports a sensor circuit 312 that includes an optical emitter 24 and optical detector 26. The flex circuit 310 provides a signal path from/to the sensor circuit 312 and speaker driver 300. In FIG. 15, the speaker driver 300 is illustrated slightly higher in the concha than would be normal in order to be able to illustrate the sensor circuit 312.

[0138] The flex circuit 310 is configured such that sensor circuit 312 touches the skin of the ear at a region containing blood vessels, such as the concha, anti-tragus, ear canal, anti-helix, helix, earlobe, behind the ear, and the like.

Performance may be best when the sensor circuit is located at the anti-tragus and/or concha, including (but not limited to) the intersection of the anti-tragus and concha of the ear E. In the illustrated embodiment, the earbud wire 314 (i.e., the electrical wire providing sound to the earbud speaker driver 300, as well as providing electrical connectivity to the sensor circuit 312) is connected to the flex circuit 310. The flex circuit 310 is configured to dampen sound vibrations from the speaker driver 300 and to provide tight coupling of the sensor circuit 312 to the skin.

[0139] In the embodiment illustrated in FIG. 16, the speaker driver 300 is positioned near the concha of the ear E, for example between the antihelix and the tragus of the ear E. A rigid sensor circuit 312 that includes an optical emitter 24 and optical detector 26 is secured to the speaker driver 300 and is electrically connected to the speaker driver 300. In the illustrated embodiment, the sensor circuit 312 is oriented to touch the skin behind the antitragus of the ear E (the skin between the anti-tragus and concha of the ear E), but other locations of the ear are also appropriate. Damping material 316 is positioned between the sensor circuit 312 and the speaker driver 300, as illustrated. The damping material 316 dampens sound vibrations from the speaker driver 300 and provides cushioned coupling with the skin of the ear E. In the illustrated embodiment, the earbud wire 314 is connected to the sensor circuit 310 and to the speaker driver 300. In FIG. 16, the speaker driver 300 is illustrated slightly higher in the concha than would be normal in order to be able to illustrate the light guides 40, 42 and sensor circuit 312.

[0140] In the embodiment illustrated in FIG. 17, the speaker driver 300 is positioned near the concha of the ear E, for example between the antihelix and the tragus of the ear E. A sensor circuit 312 that includes an optical emitter 24 and optical detector 26 is secured to the speaker driver 300 and is electrically connected to the speaker driver 300. A pair of light guides 40, 42 are in optical communication with the optical emitter 24 and optical detector 26, and a distal end of each is configured to engage the skin behind the antitragus of the ear E. Light guide 40 guides light from the optical emitter into the skin and light guide 42 collects light scattered within the ear and delivers this to the optical detector 26. In some embodiments, damping material (not shown) may be positioned between the sensor circuit 312 and the speaker driver 300 to dampen sound vibrations from the speaker driver 300. In the illustrated embodiment, the earbud wire 314 is connected to the sensor circuit 310. Although only two light guides 40, 42 are illustrated in FIG. 17, it is understood that more than two light guides may be utilized.

[0141] In the embodiment illustrated in FIG. 18A, the speaker driver 300 is positioned within the ear E, for example between the antihelix and the tragus of the ear E. A flex circuit 310 containing an optical emitter 24 and detector 26 is electrically connected to the speaker driver 300 and extends from the speaker driver 300 into the ear canal. The emitter 24 and detector 26 are configured to emit and detect light along the skin of the ear canal and/or the tympanic membrane. As illustrated in FIG. 18B, the speaker driver 300 includes pads 320 for electrically connecting to the speaker wire and pads for electrically connecting to the flex circuit 310.

[0142] The flex circuit supports a sensor circuit 312 that includes an optical emitter 24 and optical detector 26. The

flex circuit 310 provides a signal path from/to the sensor circuit 312 and speaker driver 300. The flex circuit 310 is configured to dampen sound vibrations from the speaker driver 300 and to provide tight coupling of the sensor circuit 312 to the skin within the ear canal. In the illustrated embodiment, the earbud wire 314 is connected to the speaker driver 300.

[0143] In the embodiment illustrated in FIG. 19, the speaker driver 300 is positioned within the ear E, for example between the antihelix and the tragus of the ear E. A sensor circuit 312 that includes an optical emitter 24 and optical detector 26 is secured to the speaker driver 300 and is electrically connected to the speaker driver 300. Damping material 316 is positioned between the sensor circuit 312 and the speaker driver 300 to dampen sound vibrations from the speaker driver 300. A pair of light guides 40, 42 are in optical communication with the optical emitter 24 and optical detector 26, and the light guides 40, 42 are configured to extend into the ear canal and engage the skin in the ear canal and/or the tympanic membrane. Light guide 40 guides light from the optical emitter into the ear and light guide 42 collects light scattered within the ear and delivers this to the optical detector 26. In the illustrated embodiment, the earbud wire 314 is connected to the speaker driver 300. In FIG. 19, the light guides 40, 42 are configured to direct light linearly between the emitter 24 and detector 26 and the ear E. Also, the emitter light is directed towards the concha of the ear and the detector collects light scattered by the concha of the ear.

[0144] In the embodiment illustrated in FIG. 20, the speaker driver 300 is positioned within the ear E, for example between the antihelix and the tragus of the ear E. An earbud wire 314 is connected to the speaker driver 300 and to a sensor circuit 312. The sensor circuit 312 is configured to be positioned within the ear canal and includes an optical emitter 24 and optical detector 26.

[0145] FIGS. 21A-21B and 22A-22B further illustrate the speaker driver embodiment of FIG. 20 situated near or inside the ear canal. In FIGS. 21A-21B and 22A-22B, the sensor circuit 312 is shown to be configured to be flexibly placed within the ear canal to couple with the ear canal and/or tympanic membrane. An additional flex connection or wire from the audio driver may also be available for additional sensors or actuators, such as at least one mechanical or acoustical actuator and/or microphones. In FIGS. 22A-22B, a structure or brace is shown to support the sensor circuit to keep it integrated together in the ear canal.

[0146] FIGS. 23-25 are block diagrams illustrating various configurations of a remote data processing unit 420 in communication with an earbud 400 having a sensor module 20, according to embodiments of the present invention. In each of the embodiments, the earbud 400 includes a speaker driver 300 and a sensor module 20, as described above. In each of the embodiments, the data processing unit 420 includes a processor 422, supporting circuitry 424, and a power source 424, such as a battery, capacitor, power regulating circuitry, energy harvesting power source, and/or a connection to an external power source, as would be understood by one skilled in the art. Data from the sensor module 20 is processed by the data processing unit 420. The data processing unit 420 is configured to communicate with another device via wired or wireless communication.

[0147] In the embodiment illustrated in FIG. 23, the processor 422 of the remote data processing unit 420 is in

analog communication with the speaker driver 300 and is in digital communication with the sensor module 20.

[0148] In the embodiment illustrated in FIG. 24, the processor 422 of the remote data processing unit 420 is in digital communication with the sensor module 20. The sensor module 20 may include a digital to analog converter to provide an audio signal to the speaker driver 300.

[0149] In the embodiment illustrated in FIG. 25, the processor 422 of the remote data processing unit 420 communicates with the speaker driver 300 of the earbud 400 via analog communication with an embedded digital signal. In some embodiments, this analog communication may be wired and in others it may be wireless. The embedded digital signal may be “quasi-digital”, as a modulated signal within the analog signal, such that both audio information and biometric sensor information are integrated within the analog signal. Such modulation may be achieved on the earbud 400 itself (as represented by the “+” sign in FIG. 25) using modulation techniques that are well-known by those skilled in the art (see, for example, U.S. Patent Application Publication No. 2014/0140567, which is incorporated herein by reference in its entirety). The data processing unit 420 may be located with the earbud 400 or may be located away from the earbud 400, with analog communication between the data processing unit 420 and the earbud 400. At least part of the functionality of the data processing unit 420 may comprise demodulation of the audio+biometric sensor signals, such that each can be addressed separately for audio communication and biofeedback. The data processing unit 420 may be in wireless or wired communication with an external device or external circuitry. A key benefit of the illustrated embodiment is that it enables the data processing unit 420 to be integrated within a smartphone or other smart device via the analog audio jack of the device, with analog communication to the earbud 400. Thus, a separate digital connection to the smart device would not be required in such a configuration, as both the audio and biometric signals are modulated and demodulated in an analog fashion.

[0150] FIG. 26 is a block diagram of an earbud 400 having both a sensor module 20 and data processing capability, according to some embodiments of the present invention. The earbud 400 may include a speaker driver 300 and a sensor module 20, as described above, and may include a processor 422, supporting circuitry 424, and a power source 424, such as a battery or a connection area to access an external power source via a port or through soldering. Data from the sensor module 20 is processed by the processor 422. The processor 422 is configured to communicate with other devices, including another earbud, via wired or wireless communication 428. The processor 422 is in analog communication with the speaker driver 300 and is in digital communication with the sensor module 20.

[0151] A key benefit of the embodiment of FIG. 26 is that it enables an integrated earbud unit. Such a design may fit within a “true wireless” wireless stereo headset, where there are two separate earpieces available for each ear, with each earpiece in wireless communication with the other. In such an embodiment, each earpiece may comprise the structure of FIG. 26, such that each earpiece comprises sensors and supports audio communication. Moreover, having the driver circuitry, light-guiding, and sensor circuitry integrated as a unit can help reduce the spacing requirements for such a dual-wireless design, where space is fundamentally limited by the size of a subject's ears.

[0152] FIG. 27 illustrates a pair of earbuds 400 according to some embodiments of the present invention. Each earbud 400 includes a speaker driver 300 and sensor module 20, as described above. Each earbud 400 is connected to a remote data processing unit 420, which may include a processor, supporting circuitry, and a power source, as described above. Data from each sensor module 20 is processed by the data processing unit and can be communicated to other devices via wired or wireless communication.

[0153] FIG. 28 illustrates an earbud 400 having both a sensor module 20 and data processing capability, according to some embodiments of the present invention. The earbud 400 includes a speaker driver 300 and a sensor module 20, as described above. The earbud 400 also includes a processor 422, supporting circuitry 424, and a power source 426, such as a battery, enclosed within a housing 430. The housing 430 is configured to be supported by the ear of a subject. Data from the sensor module 20 is processed by the processor 422. The processor 422 is configured to communicate with other devices via wired or wireless communication. As described above with respect to FIG. 26, this embodiment may comprise two separate earbuds 400 in wireless communication with each other. Moreover, the electronics may be integrated completely with the earbuds 400 alone, such that earhooks may not be required.

[0154] FIGS. 29-31 illustrate a speaker driver 300 having integrated light guiding, with sensor locations positioned in various spots within an ear E of a subject, according to some embodiments of the present invention. These figures show designs where the light guiding couples between the speaker driver 300 and sensor module 20, and wherein the sensor module 20 is located at various regions of the ear E. The light guiding may be supported by the earbud housing (not shown), by adhesive (such as glue or welding byproducts), overmolding, integrated alignment tabs, or the like. To simplify the image to emphasize sensor placement, the separations and barrier regions between the emitter and detector light-guiding is not shown (however, examples are provided in FIG. 12 and FIG. 13). FIG. 29 shows a configuration where the light is guided towards a region of the ear E between the anti-tragus and concha of the ear. FIG. 30 shows a configuration where the light is guided between the anti-helix and concha of the ear E. FIG. 31 shows how the light guiding may be configured, with the sensor module removed for clarity. The light guiding may also be contoured to couple from the sensor elements on the speaker driver 300 to the concha of the ear or other ear location.

[0155] In some embodiments, one or both of the light guides 40, 42 may be surrounded or partially surrounded by a cladding/barrier material 112 that is configured to at least partially block light from an external source from entering one or both of the light guides 40, 42 at select locations along the light guides 40, 42 and/or at least partially confine light within one or both light guides 40, 42. The cladding/barrier material 112 may be a light blocking material and/or a light reflective material and/or a material that has a higher optical scattering coefficient than the light guiding material of the light guides 40, 42. For example, the cladding material 112 may be a dark (e.g., black, etc.) or silver (or other reflective color) coating, a material with refractive index that differs from (i.e., is less than) the core light guide material, or a texturized light-scattering material on one or more portions of a distal end surface 40c, 42c of one or both of the light guides 40, 42.

[0156] FIGS. 32A-32F illustrate a biometric monitoring device 200 configured to be secured within an ear of a user and that may incorporate the sensor module 20 and light guides 40, 42 described above. The illustrated device 200 includes an earpiece body 202, a sensor module 204, a stabilizer 206, a sound port 208, and a connection point 210. The sensor module 204 includes angled light guides 40, 42 as described above with respect to FIG. 2. The illustrated device 200 is configured to be positioned within an ear of a user so as to reduce movement of the device 200. The various components are designed to matingly engage with specific contact points within an ear. For example, the sensor module 204 is configured to engage the region between the anti-tragus and concha of the ear and the stabilizer is configured to engage the anti-helix.

[0157] The illustrated device 200 is designed such that its center of gravity CG (FIGS. 32A-32C) is positioned at a location that provides enhanced stability to the device 200 when positioned within an ear of a user. The illustrated location of the CG helps prevent the device 200 from becoming dislodged from an ear of a user during user movement, including extreme activities, such as running and exercising. Moreover, the location of the CG is such that the device 200 is resistant to rotation when positioned within the ear of a user.

[0158] The center of gravity CG of the illustrated device 200 is located along the intersection of orthogonal planes PL1 and PL2 (FIGS. 32D-32F). As illustrated, plane PL2 bisects the center of the sensor module 204 and, in this particular embodiment, the center of gravity CG of the device 200 goes through the middle of the anti-tragus/concha divide in the ear, where the sensor module 204 of the monitoring device 200 is aligned.

[0159] FIGS. 33 and 34 illustrate an optical sensor module 20 that can be used with various monitoring devices in proximity to the skin, such as monitoring devices that are integrated into earbuds, armbands, wristbands, rings, patches, eyewear, headbands, and the like, according to some embodiments of the present invention. The illustrated sensor module 20 includes a substrate or base 22 (e.g., a circuit board, etc.) having an optical source 24 and an optical detector 26 on one side 22a thereof. The base 22 may support and/or be connected to various electronic components including, but not limited to, a signal processor, a wireless module for communicating with a remote device, a memory storage device, etc. Moreover, a battery, such as a lithium polymer battery or other portable battery, may be mounted to or connected to the base 22 and may be charged via a charge port, such as a USB charge port for example. Additionally, the base 22 may be flexible, or rigid, or may be formed from a combination of flexible and rigid material, or various other base constructs suitable for supporting electronics. In the illustrated embodiment, a capacitor 24c for driving the optical source 24 and an accelerometer 27 are mounted to an opposite side 22b of the base 22.

[0160] The optical source 24 may be one or more light-emitting diodes (LED), laser diodes (LD), organic light-emitting diodes (OLEDs), compact incandescent bulbs, micro-plasma emitters, IR blackbody sources, or the like. The optical detector 26 may be one or more photodiodes, photodetectors, phototransistors, thyristors, solid state devices, optical chipsets, or the like.

[0161] A housing 30 is secured to the base 22 and overlies the optical source 24 and optical detector 26. The illustrated

housing 30 has a curved outer surface 32 that is configured to engage a particular portion of the body of a user of the sensor module 20. For example, in some embodiments, the sensor module 20 may be incorporated into an earbud and the housing outer surface 32 is contoured to matingly engage a particular region of the ear (e.g., the region between the anti-tragus and the concha, the region along the helix or anti-helix of the ear, the skin of the ear canal, etc.). However, the housing outer surface 32 may have various shapes and configurations and need not be curved. For example, a wristband module applying the invention may have a flat housing outer surface 32.

[0162] The housing 30 includes a first light guide 40 in optical communication with the optical source 24 and a second light guide 42 in optical communication with the optical detector 26. In addition to supporting the first and second light guides 40, 42, the housing 30 may be configured to enclose and protect the various electronic components mounted to the base 22 from ambient interference (air, humidity, particulates, electromagnetic interference, etc.).

[0163] The housing 30 also includes a first light polarizing element 90 in optical communication with the optical source 24, and a second light polarizing element 92 in optical communication with the optical detector 26. The first polarizing light element 90 is configured to polarize light emitted by the optical source 24, and the second light polarizing element 92 is configured to polarize light detected by the optical detector 26. Although illustrated as first and second light polarizing elements 90, 92, in some embodiments, the sensor module 20 may utilize a single polarizing element that is in optical communication with one or both of the optical source 24 and optical detector 26.

[0164] In some embodiments, the first and second light polarizing elements 90, 92 have the same light polarization orientation (i.e., parallel planes of polarization). In other embodiments, the first and second light polarizing elements 90, 92 have respective different light polarization orientations. For example, the first and second light polarizing elements 90, 92 may have planes of polarization that are orthogonal (i.e., 90°) to each other.

[0165] In some embodiments, one or both of the first and second light polarizing elements 90, 92 may be a light polarizing film. In other embodiments, one or both of the first and second light polarizing elements 90, 92 may be a light polarizing lens. In other embodiments, one or both of the first and second light guides 40, 42 may include light polarizing material that serves the function of light polarizing elements 90, 92.

[0166] The illustrated sensor module housing 30 includes first and second windows 33a, 33b of optically transparent material through which light from the optical source passes and through which light detected by the optical detector passes, respectively. In some embodiments, the material of one or both of the first and second windows 33a, 33b may include polarizing material (e.g., a polarizing film, etc.) that serves as a polarizing element. One or both of the first and second windows 33a, 33b may also be configured to act as a lens.

[0167] In the illustrated embodiment of FIG. 34, the first and second light polarizing elements 90, 92 are polarizing films. Light  $L_e$  emitted by the optical source 24 is polarized via the first light polarizing element 90, enters the skin S of a subject being monitored via the sensor module 20 and exits the skin S as modulated light  $L_m$ . The modulated light  $L_m$  is

polarized via the second light polarizing element **92** prior to entering the light detector **26**. Some of the polarized light emitted by the light source **24** is reflected off (indicated by  $L_r$ ) of the skin **S** of the subject. The second light polarizing element **92** suppresses this reflected light  $L_r$ . The modulated light  $L_m$  that exits the skin **S** of the subject tends to be depolarized, and up to 50% of this light will traverse the second light polarizing element **92**. In principle, light that is specularly reflected off the skin, which will have little if any desired blood flow (or other physiological) information about the subject wearing the module **20**, will be sharply attenuated by a cross-polarization orientation of the first and second light polarizing elements **90, 92**, with at least one of the first and second polarizing elements **90, 92** being off-axis with the other by approximately 90-degrees. Thus, during times of high skin motion, such as during running or during other aggressive exercise by the subject wearing the sensor module **20**, specularly reflected motion artifacts may be attenuated such that mostly optical scatter signals from below the skin **S** will reach the optical detector **26**.

**[0168]** Any suitable light polarizing material which will produce a light polarization effect may be utilized as the first and second light polarizing elements **90, 92** in the context of the present invention. Exemplary polarizing material that can be used in accordance with embodiments of the present invention is available from American Polarizers, Inc., Reading, Pa., as well as Edmund Optics, Barrington, N.J.

**[0169]** The light-guiding material itself, or the lens material, may comprise polarizing material. Additionally, it should be noted that in some embodiments the polarizing material **90, 92** should be located on the outside of the light guides **40, 42** (as shown in FIG. **35**), as the light-guiding itself may be depolarizing, depending on the material used and the structure of the light guide, and hence defeat the purpose of having polarizers at all. In such case, a polarization coating or filter on top of each light guide **40, 42** may be most effective. Such a film can be deposited, textured (etched, machined, imprinted, etc.), laminated, glued, or the like.

**[0170]** Referring now to FIG. **35**, a sensor module **20** configured to be worn by a subject according to other embodiments of the present invention is illustrated. The sensor module **20** includes a housing **30** that supports an optical source **24** and an optical detector **26**. A barrier **112** may be located between the optical source **24** and the optical detector **26** to reduce or eliminate cross-talk between the optical source **24** and optical detector **26**. The housing also supports a first light polarizing element **90** in optical communication with the optical source **24** that is configured to polarize light emitted by the optical source **24**, and a second light polarizing element **92** in optical communication with the optical detector **26** that is configured to polarize light detected by the optical source **24**. The sensor module **20** may have a similar construction as the sensor module **20** of FIG. **34**.

**[0171]** In some embodiments, the first and second light polarizing elements **90, 92** have the same light polarization orientation (i.e., parallel planes of polarization). In other embodiments, the first and second light polarizing elements **90, 92** have respective different light polarization orientations. For example, the first and second light polarizing elements **90, 92** may have planes of polarization that are orthogonal (i.e., 90°) to each other.

**[0172]** In some embodiments, one or both of the first and second light polarizing elements **90, 92** may be a light polarizing film. In other embodiments, one or both of the first and second light polarizing elements **90, 92** may be a light polarizing lens which may couple to light guides (not shown). In other embodiments, the housing **30** may include first and second windows as described above with respect to FIG. **34**. In some embodiments, the first and second windows may include polarizing material that serve as the polarizing elements **90, 92**.

**[0173]** The illustrated sensor module **20** is secured to a portion of the body **B** of a subject via a band or strap **34**. For example, the body portion **B** may be a digit, an arm, a leg, a torso, etc., of a subject. Light  $L_e$  emitted by the light source **24** traverses the light polarizing element **90** and either enters the body **B** or is reflected off of the surface of the body **B**. Light that enters the body **B** scatters multiple times, and is becomes depolarized  $L_m$ , such that when it exits the wrist, much of the light  $L_m$  can traverse the second light polarizing element **92** and be detected by the light detector **26**. Reflected light  $L_r$  can be filtered out by the second light polarizing element **92** and can therefore be kept from the light detector **26**. As such, the light detector **26** can detect primarily light from the light source **24** that has travelled through the tissue of the body **B**.

**[0174]** Any suitable light polarizing material which will produce a light polarization effect may be utilized as the first and second light polarizing elements **90, 92** in the context of the present invention.

**[0175]** The foregoing is illustrative of the present invention and is not to be construed as limiting thereof. Although a few exemplary embodiments of this invention have been described, those skilled in the art will readily appreciate that many modifications are possible in the exemplary embodiments without materially departing from the teachings and advantages of this invention. Accordingly, all such modifications are intended to be included within the scope of this invention as defined in the claims. The invention is defined by the following claims, with equivalents of the claims to be included therein.

That which is claimed is:

1. An apparatus, comprising:

- a digital camera configured to capture a plurality of images of a region of a body of a subject;
- a photoplethysmography (PPG) sensor configured to sense blood flow information from the subject; and
- a processor in communication with the digital camera and the PPG sensor, wherein the processor is configured to analyze a blood flow information signal from the PPG sensor and determine a heart rate frequency and/or a breathing rate frequency of the subject, and wherein the processor is configured to analyze the plurality of images and determine whether or not a portion of the region of the body is modulating at a frequency that is similar to the heart rate frequency and/or the breathing rate frequency of the subject.

2. The apparatus of claim 1, wherein the processor is further configured to:

- identify pixels in the plurality of images that are changing at a rate that is substantially equivalent to the heart rate frequency and/or the breathing rate frequency of the subject; and

selectively amplify a signal level of the identified pixels with respect to other pixels in the plurality of images to enhance contrast of the identified pixels from the other pixels.

3. The apparatus of claim 1, further comprising a motion sensor configured to detect motion of the body of the subject, and wherein the processor is configured to attenuate frequencies associated with detected body motion from the blood flow information prior to determining the heart rate frequency and/or the breathing rate frequency of the subject.

4. The apparatus of claim 2, wherein the processor is further configured to generate an assessment of a blood analyte along a subject blood vessel by ratioing intensities of two or more wavelengths from the selectively amplified pixels, wherein the blood analyte is one or more of the following: hemoglobin, bilirubin, lactate, and glucose.

5. The apparatus of claim 2, wherein the processor is further configured to generate an assessment of changes in shape of a subject blood vessel along its length from the selectively amplified pixels.

6. The apparatus of claim 2, wherein the processor is further configured to characterize static and/or dynamic changes in a subject blood vessel and generate a biometric identification of the subject using the selectively amplified pixels.

7. The apparatus of claim 6, wherein the processor is further configured to compare a characterization of a blood vessel with a stored characterization of the blood vessel to determine similarity.

8. The apparatus of claim 1, wherein the apparatus is a portable telecommunication device.

9. An apparatus, comprising:

a digital camera configured to capture a plurality of images of a region of a body of a subject;

a photoplethysmography (PPG) sensor configured to sense blood flow information from the subject; and

a processor in communication with the digital camera and the PPG sensor, wherein the processor is configured to analyze a blood flow information signal from the PPG sensor and determine a heart rate frequency and/or a breathing rate frequency of the subject, and wherein the processor is configured to analyze the plurality of images and identify one or more portions of the region of the body that are not modulating at a frequency that is similar to the heart rate frequency and/or the breathing rate frequency of the subject.

10. The apparatus of claim 9, wherein the processor is configured to identify the one or more portions of the region of the body of the subject that are not modulating at a frequency that is similar to the heart rate frequency and/or the breathing rate frequency of the subject by identifying pixels in the plurality of images that are not changing at a rate that is substantially equivalent to the heart rate frequency and/or the breathing rate frequency.

11. The apparatus of claim 10, wherein the processor is further configured to selectively amplify a signal level of the identified pixels with respect to other pixels in the plurality of images to enhance contrast of the identified pixels from the other pixels.

12. The apparatus of claim 9, further comprising a motion sensor configured to detect motion of the body of the subject, and wherein the processor is configured to attenuate frequencies associated with detected body motion from the

blood flow information prior to determining the heart rate frequency and/or the breathing rate frequency of the subject.

13. The apparatus of claim 9, wherein the apparatus is a portable telecommunication device.

14. A method of sensing biometric information from a subject via an electronic device, wherein the electronic device comprises a digital camera, a photoplethysmography (PPG) sensor, and a processor in communication with the digital camera and the PPG sensor, the method comprising:

capturing a plurality of images of a region of a body of the subject via the digital camera;

sensing blood flow information from the subject via the PPG sensor;

analyzing a blood flow information signal from the PPG sensor via the processor to determine a heart rate frequency and/or a breathing rate frequency of the subject; and

analyzing the plurality of images via the processor to determine whether or not a portion of the region of the body is modulating at a frequency that is similar to the heart rate frequency and/or the breathing rate frequency of the subject.

15. The method of claim 14, wherein analyzing the plurality of images comprises identifying pixels in the plurality of images that are changing at a rate that is substantially equivalent to the heart rate frequency and/or the breathing rate frequency of the subject, and selectively amplifying, via the processor, a signal level of the identified pixels with respect to other pixels in the plurality of images to enhance contrast of the identified pixels from the other pixels.

16. The method of claim 14, wherein the electronic device includes a motion sensor, and wherein the method further comprises detecting motion of the body of the subject via the motion sensor, and attenuating frequencies associated with the detected body motion from the blood flow information signal via the processor prior to determining the heart rate frequency and/or the breathing rate frequency of the subject.

17. The method of claim 15, further comprising generating, via the processor, an assessment of a blood analyte along a subject blood vessel by ratioing intensities of two or more wavelengths from the selectively amplified pixels, wherein the blood analyte is one or more of the following: hemoglobin, bilirubin, lactate, and glucose.

18. The method of claim 15, further comprising generating, via the processor, an assessment of changes in shape of a subject blood vessel along its length from the selectively amplified pixels.

19. The method of claim 15, further comprising characterizing, via the processor, static and/or dynamic changes in a subject blood vessel and generating a biometric identification of the subject using the selectively amplified pixels.

20. The method of claim 19, further comprising comparing, via the processor, a characterization of a blood vessel with a stored characterization of the blood vessel to determine similarity.

21. The method of claim 14, wherein the electronic device is a portable telecommunication device.

22. A method of sensing biometric information from a subject via an electronic device, wherein the electronic device comprises a digital camera, a photoplethysmography (PPG) sensor, and a processor in communication with the digital camera and the PPG sensor, the method comprising:

capturing a plurality of images of a region of a body of the subject via the digital camera;

sensing blood flow information from the subject via the PPG sensor;

analyzing a blood flow information signal from the PPG sensor via the processor to determine a heart rate frequency and/or a breathing rate frequency of the subject; and

analyzing the plurality of images via the processor to identify one or more portions of the region of the body of the subject that are not modulating at a frequency that is similar to the heart rate frequency and/or the breathing rate frequency of the subject.

**23.** The method of claim **22**, wherein identifying the one or more portions of the region of the body of the subject that are not modulating at a frequency that is similar to the heart rate frequency and/or the breathing rate frequency of the subject comprises identifying pixels in the plurality of

images that are not changing at a rate that is substantially equivalent to the heart rate frequency and/or the breathing rate frequency.

**24.** The method of claim **23**, further comprising selectively amplifying, via the processor, a signal level of the identified pixels with respect to other pixels in the plurality of images to enhance contrast of the identified pixels from the other pixels.

**25.** The method of claim **22**, wherein the electronic device further comprises a motion sensor configured to detect motion of the body of the subject, and wherein the method further comprises attenuating, via the processor, frequencies associated with detected body motion from the blood flow information signal prior to determining the heart rate frequency and/or the breathing rate frequency of the subject.

**26.** The method of claim **22**, wherein the electronic device is a portable telecommunication device.

\* \* \* \* \*

专利名称(译)	光学监测设备和方法		
公开(公告)号	<a href="#">US20180042554A1</a>	公开(公告)日	2018-02-15
申请号	US15/794728	申请日	2017-10-26
[标]申请(专利权)人(译)	瓦倫賽爾公司		
申请(专利权)人(译)	VALENCELL INC.		
当前申请(专利权)人(译)	VALENCELL INC.		
[标]发明人	WAGNER WOLFGANG STEPHENSON SHAWN JUST STEVEN MATTHEW AUMER MICHAEL EDWARD TUCKER JESSE BERKLEY ESCHBACH LAWRENCE CHRISTOPHER LEBOEUF STEVEN FRANCIS		
发明人	WAGNER, WOLFGANG STEPHENSON, SHAWN JUST, STEVEN MATTHEW AUMER, MICHAEL EDWARD TUCKER, JESSE BERKLEY ESCHBACH, LAWRENCE CHRISTOPHER LEBOEUF, STEVEN FRANCIS		
IPC分类号	A61B5/00		
CPC分类号	A61B2562/0233 A61B5/6815 A61B5/6898 A61B5/14552 A61B2562/0238 A61B5/0261 A61B5/1455 A61B5/6802 A61B5/6803 A61B5/721 H04R1/1016 H04R1/1091		
优先权	15/324139 2017-01-05 US PCT/US2015/041562 2015-07-22 WO 62/033922 2014-08-06 US		
其他公开文献	US10623849		
外部链接	<a href="#">Espacenet</a> <a href="#">USPTO</a>		

摘要(译)

一种设备包括：数字照相机，配置为捕获对象的身体的区域的多个图像；光电容积脉搏波（PPG）传感器，配置为感测来自对象的血流信息；以及处理器，与数字照相机和PPG传感器。处理器被配置成分析来自PPG传感器的血流信息信号并确定受试者的心率频率和/或呼吸频率。处理器还被配置为分析多个图像并确定身体的一部分区域是否以与受试者的心率频率和/或呼吸频率相似的频率进行调制。

