



US 20140180046A1

(19) **United States**

(12) **Patent Application Publication**
Campbell et al.

(10) **Pub. No.: US 2014/0180046 A1**

(43) **Pub. Date: Jun. 26, 2014**

(54) **METHOD AND SYSTEM FOR MONITORING INTRACRANIAL PRESSURE**

(71) Applicant: **COVIDIEN LP**, MANSFIELD, MA (US)

(72) Inventors: **Shannon E. Campbell**, Boulder, CO (US); **Clark R. Baker, JR.**, Newman, CA (US)

(73) Assignee: **COVIDIEN LP**, MANSFIELD, MA (US)

(21) Appl. No.: **14/195,535**

(22) Filed: **Mar. 3, 2014**

Related U.S. Application Data

(63) Continuation of application No. 11/528,218, filed on Sep. 27, 2006, now Pat. No. 8,696,593.

Publication Classification

(51) **Int. Cl.**
A61B 5/03 (2006.01)
A61B 5/00 (2006.01)
A61B 5/0205 (2006.01)

(52) **U.S. Cl.**
 CPC *A61B 5/031* (2013.01); *A61B 5/0205* (2013.01); *A61B 5/6814* (2013.01)
 USPC **600/324; 600/479**

(57) **ABSTRACT**

Embodiments of the present invention relate to a system and method for monitoring intracranial pressure. Embodiments of the present invention include emitting an electromagnetic wavelength into forehead tissue of a patient and detecting characteristics of the electromagnetic wavelength after the electromagnetic wavelength has been scattered by the tissue. The characteristics may include variations in the electromagnetic wavelength corresponding to a pulse. Further, embodiments of the present invention include analyzing the variations to identify venous pulsations, and determining whether intracranial pressure is elevated in the patient based on a correlation between the venous pulsations and levels of intracranial pressure.

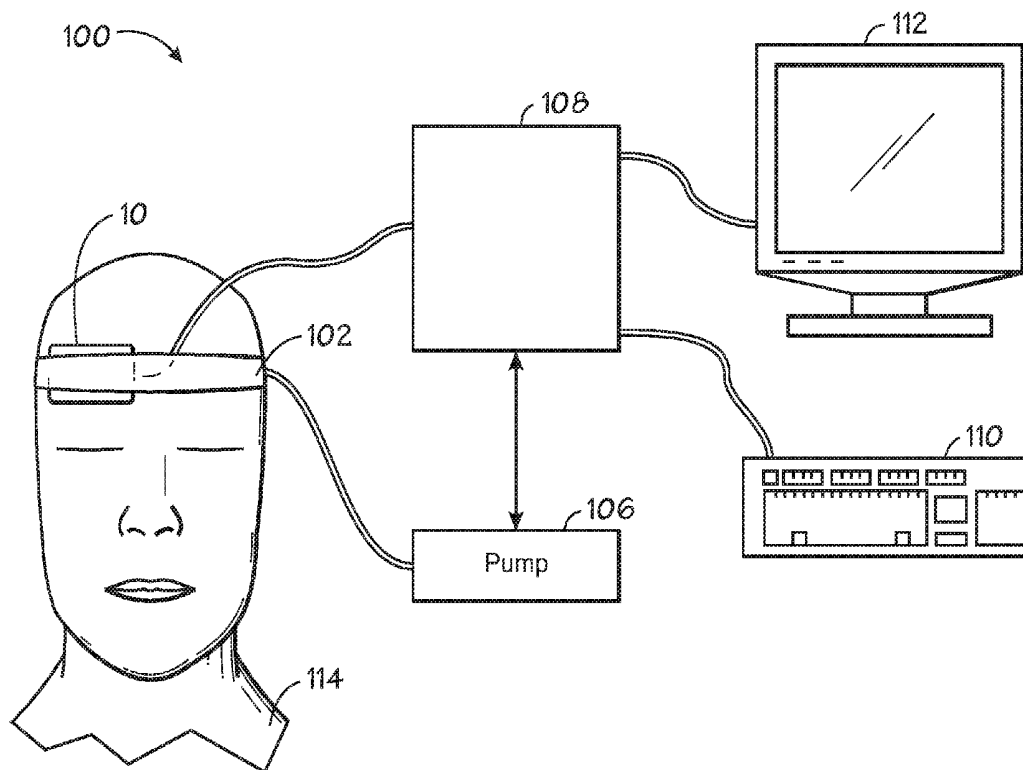

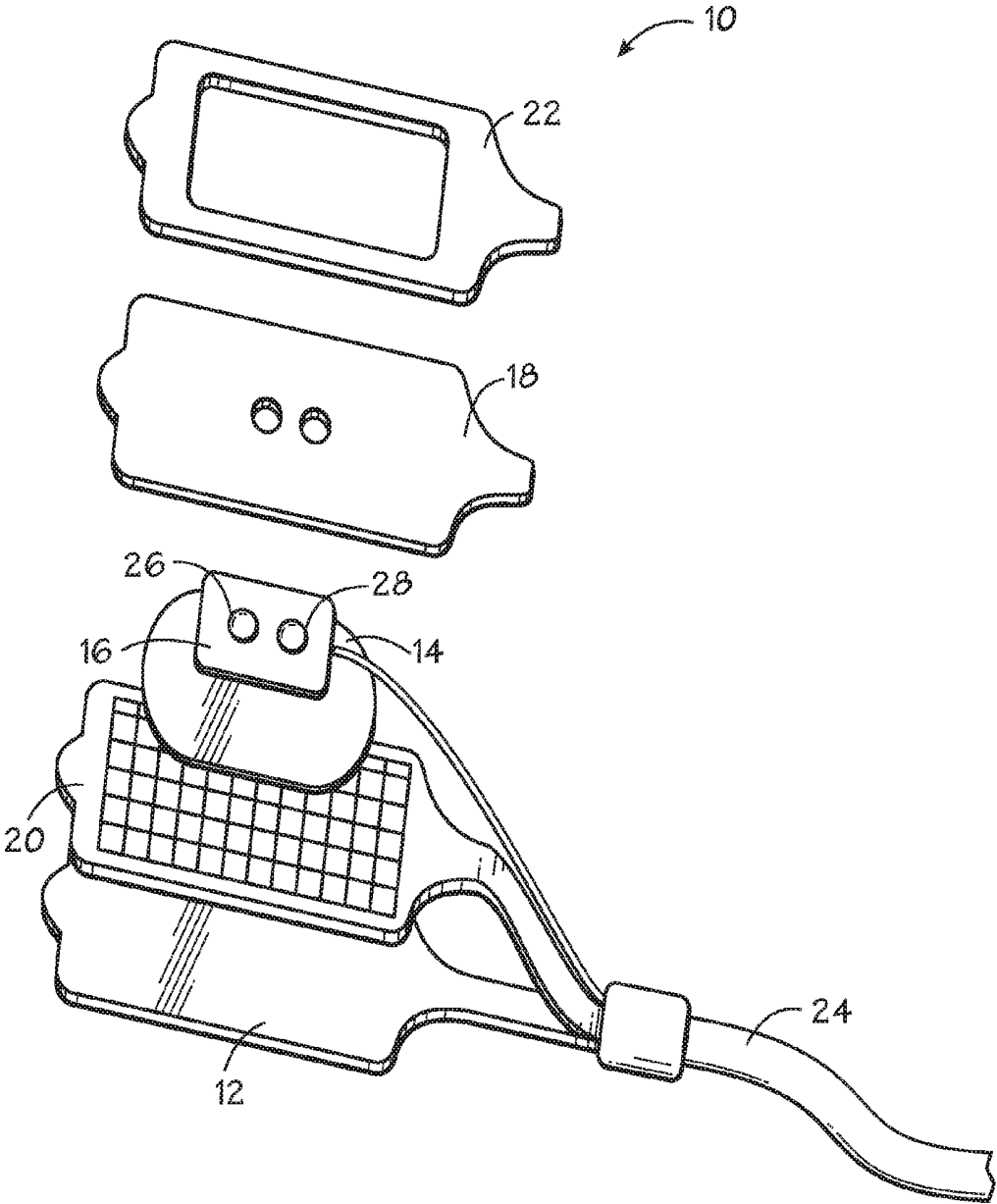

FIG. 1

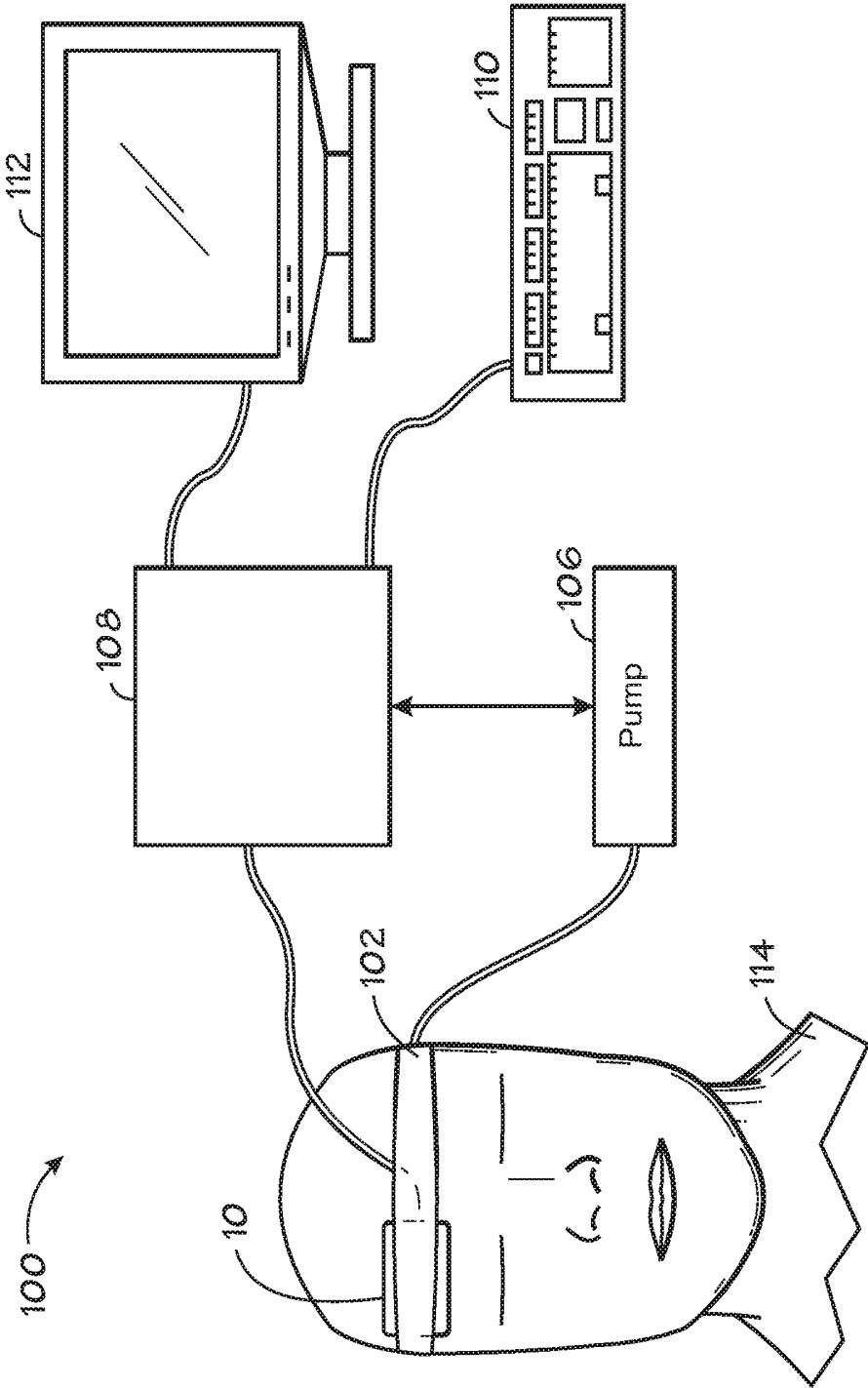

FIG. 2

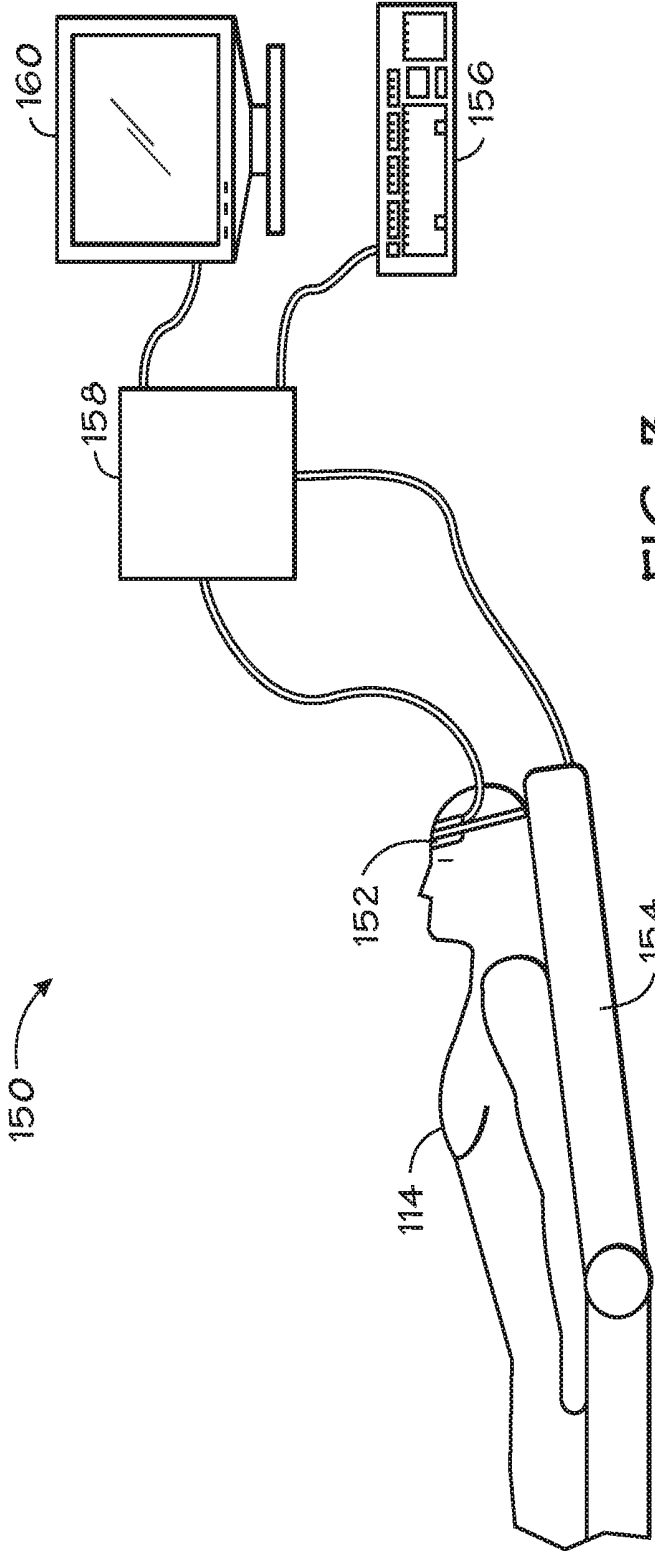

FIG. 3

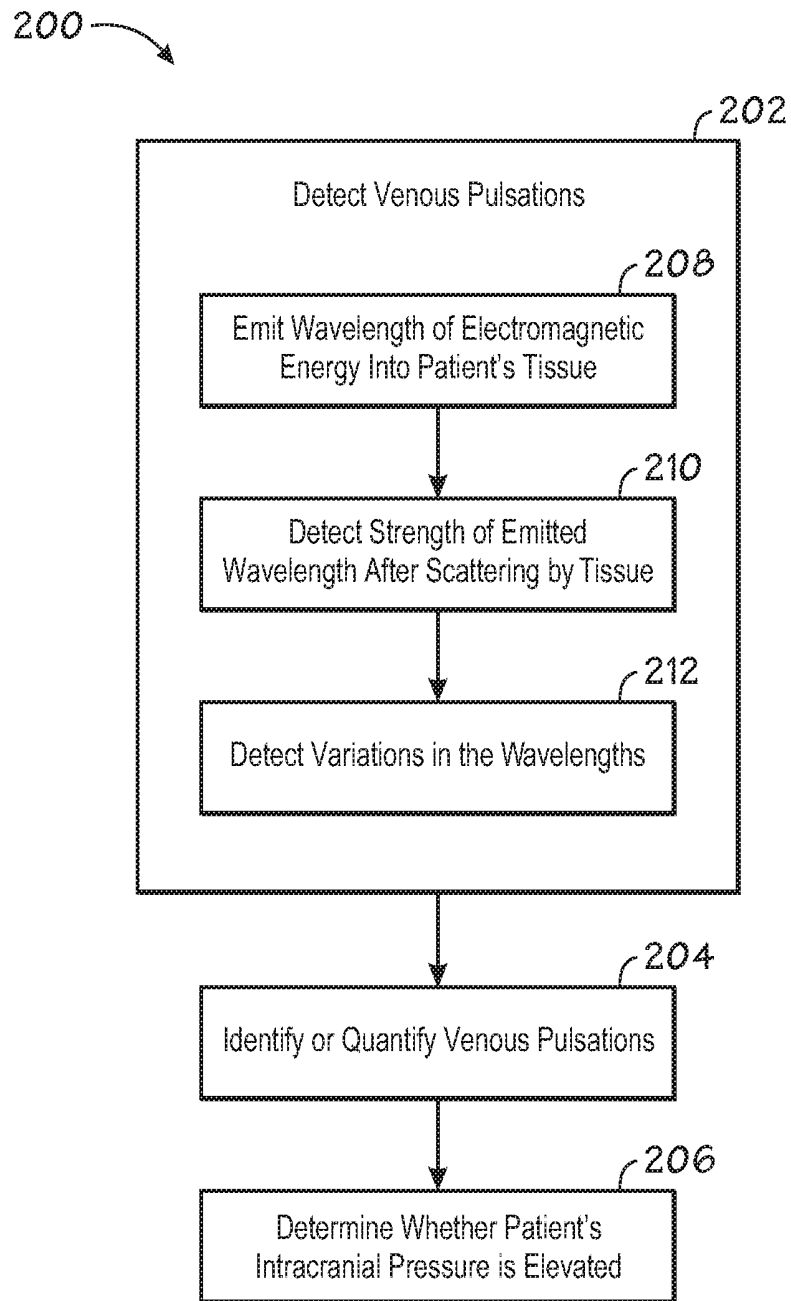

FIG. 4

METHOD AND SYSTEM FOR MONITORING INTRACRANIAL PRESSURE

CROSS REFERENCE TO RELATED APPLICATIONS

[0001] This application is a continuation of prior U.S. application Ser. No. 11/528,218, filed Sep. 27, 2006, the specification of which is incorporated by reference in its entirety.

BACKGROUND OF THE INVENTION

[0002] 1. Field of the Invention

[0003] The present invention relates generally to a method and system for detecting elevated intracranial pressure. Specifically, embodiments of the present invention relate to using venous pulsation signals obtained from a patient's forehead to non-invasively detect elevated intracranial pressure. Further, some embodiments are directed to quantifying intracranial pressure based on a pressure or elevation required to overcome the venous pulsations.

[0004] 2. Description of the Related Art

[0005] This section is intended to introduce the reader to various aspects of art that may be related to various aspects of the present invention, which are described and/or claimed below. This discussion is believed to be helpful in providing the reader with background information to facilitate a better understanding of the various aspects of the present invention. Accordingly, it should be understood that these statements are to be read in this light, and not as admissions of prior art.

[0006] The human skull is essentially a rigid fluid-filled container. Principle constituents within the skull include brain tissue, blood, and cerebral-spinal fluid (CSF). Because the skull is essentially rigid and has a constant volume, if there is an increase in the volume of the contents of the skull, the pressure inside the skull (i.e., intracranial pressure) will rise unless some fluid is able to escape. For example, if the brain tissue experiences swelling, a certain amount of blood or CSF must escape the skull cavity to prevent a rapid increase in pressure. During such swelling, pressure inside the skull may rise above the normal range. Further, if swelling continues until little or no fluid remains, any further swelling will cause a rapid increase in intracranial pressure (ICP). It should also be noted that obstruction of fluid flow out of the skull (e.g., obstructed venous outflow) can increase ICP because the fluid flowing into the skull will build pressure therein.

[0007] ICP is measured in millimeters of mercury (mmHg). The normal range for ICP values is from around 5 mmHg to around 13 mmHg. American and European head injury guidelines recommend that actions be taken to treat ICP when it is above 20-25 mmHg, as elevated ICP is a potentially life-threatening condition. Treatment of elevated ICP typically begins with administration of drugs to reduce systemic fluid volume or blood pressure. If the elevated ICP is not detected early enough, part of the skull may need to be removed to relieve the pressure.

[0008] While elevated ICP is often a result of trauma, the elevated pressure itself can cause damage to the central nervous system by compressing important brain structures and restricting blood flow through vessels that supply the brain. Elevated ICP typically occurs as a result of increased volume within the skull cavity. For example, elevated ICP occurs acutely in head trauma cases involving cerebral edema, which is also referred to as brain swelling. Elevated ICP may occur

more gradually in cases of hydroencephalitis (i.e., water on the brain) or brain tumors. Other conditions that may cause elevated ICP include: subdural hematoma, encephalitis, meningitis, hemorrhage, stroke, and so forth.

[0009] Traditional techniques for monitoring and measuring ICP generally involve the use of invasive devices. For example, commonly used devices include hollow screw and bolt devices. These typically include metallic cylindrical instruments which are inserted into the patient such that an instrument tip protrudes into the subarachnoid space to facilitate pressure measurement. The subarachnoid space is the compartment within the skull and spinal column that contains the CSF. Another commonly used invasive device for ICP monitoring is an intraventricular catheter. The intraventricular catheter is typically placed inside ventricles (i.e., fluid filled cavities) of the brain to facilitate pressure monitoring. Insertion of such invasive devices (e.g., hollow screws and catheters) to facilitate ICP monitoring can be dangerous. For example, insertion of a monitoring device through a patient's skull may cause hemorrhaging or infection.

[0010] Some existing techniques for monitoring ICP are non-invasive. For example, some existing methods involve emitting ultrasound into the patient's brain to facilitate detection of an elevated ICP. Such ultrasound emissions typically reach the brain through natural windows in the skull. For example, ultrasound emissions may be introduced to a patient's brain via an eye socket. However, these ultrasound emissions may be undesirable depending on how long the eye must be sonified. Further, sensor placement for such methods can be difficult, resulting in inaccuracies.

[0011] Accordingly, it is desirable to provide an improved non-invasive monitoring device for detecting and/or measuring ICP that facilitates early detection of elevated ICP.

BRIEF DESCRIPTION OF THE DRAWINGS

[0012] Advantages of the invention may become apparent upon reading the following detailed description and upon reference to the drawings in which:

[0013] FIG. 1 is an exploded perspective view of an exemplary forehead sensor configured to detect venous pulsations and facilitate estimation of intracranial pressure levels in accordance with an exemplary embodiment of the present invention;

[0014] FIG. 2 is a block diagram of an exemplary system for non-invasively monitoring a patient's intracranial pressure in accordance with an exemplary embodiment of the present invention;

[0015] FIG. 3 is a block diagram of an exemplary system for non-invasively monitoring a patient's intracranial pressure in accordance with an exemplary embodiment of the present invention; and

[0016] FIG. 4 is a block diagram of an exemplary method for detecting intracranial pressure in accordance with an exemplary embodiment of the present invention.

DETAILED DESCRIPTION OF SPECIFIC EMBODIMENTS

[0017] One or more specific embodiments of the present invention will be described below. In an effort to provide a concise description of these embodiments, not all features of an actual implementation are described in the specification. It should be appreciated that in the development of any such actual implementation, as in any engineering or design

project, numerous implementation-specific decisions may be made to achieve the developers' specific goals, such as compliance with system-related and business-related constraints, which may vary from one implementation to another. Moreover, it should be appreciated that such a development effort might be complex and time consuming, but would nevertheless be a routine undertaking of design, fabrication, and manufacture for those of ordinary skill having the benefit of this disclosure.

[0018] Embodiments of the present invention relate to using venous pulsation signals obtained from veins in a patient's forehead via a pulse detection sensor (e.g., a pulse oximeter sensor) to non-invasively detect and/or measure elevated intracranial pressure (ICP). For example, in some embodiments, a counter-pressure may be applied to the veins in a patient's forehead to cause cessation of the venous pulses, and the measured counter-pressure may be directly correlated to ICP. In other embodiments, the natural cessation of venous pulsations may be detected, which may be indicative of elevated ICP. Further, it is predicted that certain aspects of the venous pulsations will correlate directly with ICP. Accordingly, embodiments of the present invention include measuring venous pulsations in a patient's forehead and identifying and/or quantifying ICP using predicted correlations between the venous pulsations and ICP.

[0019] In some embodiments, measured adjustments (e.g., application of pressure or elevation of a patient's head) may be applied to the patient to stop detected venous pulsations. For example, in one embodiment, a measured amount of pressure may be applied to the forehead to stop the venous pulsations. Because venous blood in the forehead is in direct communication with that of the brain, the pressure required to abolish the venous pulsations will likely be equivalent to the maximum pressure in the brain, up to approximately 25 mmHg when the "window" for venous outflow become occluded. Similarly, in another embodiment, the patient's head may be elevated above the patient's heart until the venous pulsations cease. It is believed that the elevation required to stop the venous pulsations will correlate to ICP. Accordingly, the level of elevation may be measured and used to estimate ICP. For example, constant gravitational forces combined with the angle of elevation may be used in an algorithm to establish a value for ICP.

[0020] FIG. 1 is an exploded perspective view of a forehead sensor in accordance with an exemplary embodiment of the present invention. The sensor is generally indicated by reference number 10. In the illustrated embodiment, the sensor 10 includes a cover 12, a first mask layer 14, an optical measurement device 16, a second mask layer 18, a pressure sheet 20, and an adhesive layer 22. The sensor 10 may be coupled to a cord 24 to enable communication between components of the sensor 10 (e.g., the optical measurement device 16 and the pressure sheet 20) and a monitor (e.g., pulse oximeter and/or pressure mapping system). The cord 24 may also supply power to the sensor 10. In other embodiments, the sensor 10 may be powered by a battery and communicate wirelessly with the monitor.

[0021] The cover 12 serves as a protective outer layer for the sensor 10 and is exposed to the environment when the sensor 10 is attached to a patient's skin. The cover 12 may be made of polyvinyl chloride (PVC) foam, urethane foam material, or the like. The cover 12 at least partially covers and protects the optical measurement device 16, which includes an emitter 26 and a detector 28. In one embodiment, the

emitter 26 is configured to generate light (or electromagnetic energy) of at least two different wavelengths and the detector 28 is configured to detect the generated light (or electromagnetic energy). The sensor 10 is configured such that light from the emitter 26 can be directed at a patient's skin and scattered through the patient's tissue. The amount of light that diffuses through the patient's tissue will vary in accordance with the amount of blood constituent in the tissue and the corresponding light absorption. Accordingly, the amount of light detected by the detector 28 can be utilized to measure certain blood flow characteristics, such as venous pulsations.

[0022] The first and second mask layers 14 and 18 (e.g., metalized plastic film) are positioned on either side of the optical measurement device 16 to reduce or prevent secondary light (i.e., light other than that produced by the emitter 26) from interfering with the detector 18. To allow optical access to the patient, the first and second mask layers 14 and 18 do not completely cover the optical measurement device 16. For example, the second mask layer 18 has openings therein that fit over and surround portions of the optical measurement device 16 such that light can be emitted into the patient's tissue by the emitter 26 and detected by the detector 28. In one embodiment, the first and second mask layers 14 and 18 are made of a cellular urethane foam and couple to other portions of the sensor 10 with a pressure sensitive adhesive. Either of the mask layers 14 or 18 may serve as a substantially flat platform for attachment of the pressure sheet 20 and/or the adhesive layer 22.

[0023] The pressure sheet 20 is configured to work with a pressure mapping system to determine pressure levels on portions of the sheet 20. Specifically, the pressure sheet 20 may be used to measure or detect certain levels of patient/surface interface pressure. For example, the pressure sheet 20 may measure pressure applied to the patient's forehead by a clinician pressing on the sensor 10. The pressure sheet 20 may include any pressure sensing device adapted to measure dynamic and/or static pressure distribution. For example, the pressure sheet 20 may include certain pressure measurement devices provided by Tekscan, Inc. In one embodiment, the pressure sheet 20 may include a tactile sensing system that provides an essentially instantaneous assessment of topical pressure being applied to the pressure sheet 20. The pressure measured by the pressure sheet 20 may be utilized in a calculation to determine the ICP of the patient. Further, the pressure sheet 20 may communicate via an electrical connection or wirelessly with the pressure mapping system to facilitate measurement and storage of pressure data. It should be noted that in some embodiments, the pressure sheet 20 may be separate from other components of the sensor 10 or disposed on an external portion of the sensor 10.

[0024] The adhesive layer 22 is disposed on the outer portion of the sensor 10 opposite the cover 12 and is adapted to facilitate attachment of the sensor 10 to a patient. In the illustrated embodiment, the adhesive layer 22 is essentially ring shaped with an opening to facilitate optical communication between the optical measurement device 16 and the patient's tissue. The adhesive layer 22 may be dark (e.g., black) to reduce reflected light, which can impact measurement accuracy. Further, the adhesive layer 22 may include a thermally stable adhesive material to avoid compromised performance when the sensor 10 is exposed to heat. In one embodiment, the adhesive layer 22 includes a plastic strip having acrylic adhesive on one side for attachment to the

patient. In another embodiment, the adhesive layer 22 includes multiple adhesive sheets.

[0025] FIG. 2 is a block diagram of a system for non-invasively monitoring a patient's ICP in accordance with an exemplary embodiment of the present invention. The system is generally designated by reference number 100. The system 100 includes the sensor 10, an inflatable headband 102, a pump 106, a monitor 108, an input device 110, and an output screen 112. The monitor 108 may include a vital signs monitor (e.g., a pulse rate monitor, a pulse oximeter) and/or a pressure mapping device. For example, the monitor 108 may be adapted to receive input from the optical measurement device 16 of the sensor 10 relating to detecting venous pulsations. Additionally, the monitor may be adapted to receive input from the pressure sheet 20 of the sensor 10 relating to detecting an amount of pressure applied between the patient and the sensor. The monitor 108 may utilize correlations between venous pulsations and pressure measurements to facilitate estimation of ICP in accordance with embodiments of the present invention.

[0026] The system 100 is coupled to a patient 114 to allow monitoring of the patient's ICP. Specifically, the system 100 is coupled to the patient 114 via the sensor 10, which is attached to the patient's forehead and held in place by adhesive and/or the headband 102. As set forth above, the sensor 10 may be adapted to emit light into the patient's tissue and detect how the light is dispersed by the tissue to provide an estimate of certain blood flow characteristics, such as venous pulsations. This detection of venous pulsations may be achieved in accordance with known systems (e.g., pulse oximeters) and devices.

[0027] FIG. 3 is a block diagram of another system for non-invasively monitoring a patient's ICP in accordance with an exemplary embodiment of the present invention. The system is generally designated by reference number 150. The system 150 includes a pulse sensor 152, an adjustable head elevator 154, an input device 156, a monitor 158, and an output screen 160. The monitor 158 may include a vital signs monitor (e.g., a pulse rate monitor, a pulse oximeter) and/or a pressure mapping device. For example, the monitor 158 may be adapted to receive input from a component of the pulse sensor 152 (e.g., the optical measurement device 16) relating to detecting venous pulsations. Additionally, the monitor may be adapted to receive input from a sensitive pressure measurement device (e.g., the pressure sheet 20) in the pulse sensor 152 that is indicative of pulse. Further, the monitor 158 may be configured to measure a patient's head elevation based on input (e.g., an angle of inclination) from the adjustable head elevator 154. The monitor 158 may utilize correlations between detected venous pulsations and elevation measurements to facilitate estimation of ICP. For example, the adjustable head elevator 154 may be adjusted to elevate the patient's head over the level of the patient's heart until the detected venous pulsations are abolished. The angle of the adjustable head elevator 154 required to abolish the venous pulsations may then be used to calculate an estimated value of the patient's ICP.

[0028] Venous pulsations have been observed in pulse measurement data from the forehead. These pulsations are essentially synchronous with the cardiac cycle and occur more frequently under conditions that would elevate venous return from the brain. For example, venous pulsations generally occur more frequently when the head is below the heart or when venous return is restricted during a surgical procedure.

Such venous pulsations may be abolished by applying pressure to the patient's forehead. For example, in one embodiment, the headband 102 may be utilized (e.g., tightened or inflated) to apply enough pressure to abolish detected venous pulsations in a patient's forehead. Similarly, as discussed above, the adjustable head elevator 154 may be adjusted to elevate the patient's head over the level of the patient's heart to abolish the venous pulsations as a result of gravity.

[0029] It is believed that correlations may be established between venous pulsations in a patient's forehead and the patient's ICP. Such correlations are predicted based in part on how the cardiac cycle affects ICP. The cardiac cycle results in variations in cerebral blood volume. During systole, the net inflow of blood increases intracranial volume, and during diastole, the net outflow of blood decreases the intracranial volume. Because the skull is essentially a rigid container, the increase in intracranial volume caused during systole results in a pressure change. This pressure change sets up a pulse wave in both the low pressure venous blood and CSF. Pulsatile changes in venous volume tend to increase with ICP, because increased ICP generally results in less compliant brain tissue. Thus, to maintain oxygen delivery to the brain, the sympathetic nervous system will increase arterial blood pressure sufficiently to keep the veins open and facilitate blood flow through them. This indicates that, at least until a point of failure, ICP will not exceed venous pressure in the brain.

[0030] Blood from the forehead drains into the cavernous sinus inside the skull and eventually drains through the internal jugular. As such, the venous blood from the forehead is in direct communication with that of the brain. Furthermore, there are essentially no valves in these veins. This direct communication and lack of valves suggests that pressure changes associated with the venous blood inside the skull have a direct effect on the blood draining from the forehead. Accordingly, it is likely that venous pulsations observed with the forehead sensor 10, and a pressure or elevation required to overcome the venous pulsations, will correlate with intracranial venous pressure. Further, intracranial venous pressure is affected by elevated ICP. Therefore, the amount of pressure or elevation required to abolish venous pulsations observed with the forehead sensor should correlate to the maximum venous pressure in the brain.

[0031] In view of the predictive correlations discussed above, the systems 100 and 150 may detect and abolish venous pulsations in the patient's forehead to estimate ICP. Specifically, the system 100 may measure the amount of pressure or the system 150 may measure the head elevation required to abolish detected venous pulsations in the patient's forehead and then estimate ICP based on correlations between ICP and the measured pressure and/or elevation. For example, in one embodiment, the monitor 108 may calculate an estimate of ICP, or simply determine that an elevated ICP is likely, based on input from the sensor 10, the headband 102 and/or input from a clinician received via the input device 110. In another embodiment, the monitor 158 may calculate an estimate of ICP, or simply determine that an elevated ICP is likely, based on input from the pulse sensor 152, the adjustable head elevator 154, and/or input from a clinician received via the input device 156.

[0032] In one embodiment, as illustrated by FIG. 2, the headband 102 may be utilized to facilitate estimation of the patient's ICP. For example, the monitor 108 may receive signals from the sensor 10 that are indicative of venous pul-

sations. In response, the monitor **108** may cause the headband **102** to gradually inflate and increase pressure on the forehead by initiating the pump **106**. The headband **102** may be designed to distribute pressure only on certain portions of the forehead (e.g., above the patient's eyebrows). When the sensor **10** indicates that venous pulsations have ceased, the corresponding pressure measurement may be utilized to estimate ICP. Indeed, the pressure required to abolish the venous pulsations may be essentially equivalent to the ICP. This pressure measurement may be received from a pressure measuring device, such as the pressure sheet **20** or a calibrated device (e.g., an electronic pressure gauge) on the pump **106**. The measurements taken during such a process may be displayed on the screen **112** along with the estimate of ICP.

[0033] In another embodiment, as illustrated by FIG. 3, the monitor **158** may estimate ICP by adjusting the patient's head elevation. For example, the monitor **158** may receive signals from the pulse sensor **152** that are indicative of venous pulsations. In response, the monitor **158** may cause the adjustable head elevator **154** to raise the patient's head until the venous pulsations are abolished. The angle or level of elevation required to stop the pulsations may be measured and utilized by the monitor **158** along with the correlations based on the effects of gravity on arterial pressure to estimate ICP. Further, the measurements and ICP estimates may be displayed on the screen **160**.

[0034] It should be noted that in some embodiments, a clinician may control the amount of pressure and/or the patient's head elevation used to stop the venous pulsation by inputting certain pressure or elevation values into the monitor **108** or **158** via the input device **110** or **156** (e.g., a keyboard). Additionally, in some embodiments, a clinician may manually apply pressure to stop detected venous pulsations. For example, a clinician may simply press the sensor **10** with a finger, manually tighten the headband **102**, or manually adjust the patient's head elevation until detected venous pulsations are abolished. The monitor **108** or **158** may automatically receive pressure measurements from the sensor **10** or elevation measurements from the adjustable head elevator **154** that correspond to the abolishment of the detected venous pulsations and use these measurements to estimate ICP. Alternatively, the user may manually input measured pressure and elevation values.

[0035] FIG. 4 is a block diagram of a method for detecting ICP in accordance with an exemplary embodiment of the present invention. The method is generally designated by reference number **200**. The method **200** comprises three major acts. Venous pulsations in a patient's forehead are detected (block **202**). The venous pulsations are identified and/or quantified (block **204**). Whether the patient's ICP is elevated is determined based on correlations between characteristics of the venous pulsations and levels of ICP (Block **206**).

[0036] Multiple methods may be utilized in block **202** to detect venous pulsations. For example, the methods disclosed in U.S. Patent Publication No. 20050197579 and U.S. application Ser. No. 11/528,295 entitled "Method and Apparatus for Detection of Venous Pulsation," by Clark Baker, filed on Sep. 27, 2006, which are hereby incorporated by reference in their entirety, may be utilized in accordance with embodiments of the present invention. While these various methods may be used, the illustrated embodiment provides a specific example of venous pulsation detection. Indeed, in the illustrated embodiment, the method includes emitting one or more

wavelengths of electromagnetic energy (e.g., light) into the patient's forehead tissue (block **208**), detecting the strength of the emitted wavelengths after being scattered by the tissue (block **210**), and detecting variations in the wavelengths that correspond to the patient's pulse (**212**). The acts represented by blocks **208**, **210**, and **212** generally result in detection of venous pulsations in the patient's forehead, if the pulsations are present. In another embodiment, venous pulsations may be detected by comparing an oxygen saturation value computed from oximetry data obtained from a patient's forehead with an oxygen saturation value computed from oximetry data obtained from one of the patient's extremities (i.e. a digit). The veins of the extremities have valves that keep venous blood from backing up and pulsing. Accordingly, an oximetry sensor on the extremity can be presumed to produce values reflective of arterial oxygen saturation, whereas a forehead oximetry sensor can be presumed to produce lower values (i.e., values that are intermediate between arterial and venous oxygen saturation), when venous pulsation occurs at this site. Further, venous pulsations may be detected by analyzing phase differences between signals at the forehead site and an ECG (electrocardiogram) signal.

[0037] As set forth above, block **204** represents identifying or quantifying the venous pulsations. This may be achieved by analyzing the variations in the wavelengths detected in block **212**. In one embodiment, it is believed that an analysis of the shape of the variations may facilitate identification or quantification of the venous pulsations for correlation with ICP levels. For example, height and width measurements of the wavelengths may be combined with heart rate measurements to establish ICP correlations. In another embodiment, the analysis may include observations relating to phase differences between variations in multiple wavelengths. In yet another embodiment, the analysis may include observations relating to ratios of the variations in multiple wavelengths. For example, wavelengths may be emitted and detected on various parts of the patient's forehead and corresponding variation ratios may be indicative of ICP. Alternatively, it is believed that time and frequency analysis of the venous pulsations, either by themselves or relative to the cardiac cycle, may be used to elucidate ICP information. For example, spectral analysis of decomposed frequency domains or complex algorithms (e.g., geometric measures, non-linear dynamics, power law scaling, detrended fluctuation analysis, or Shannon entropy). It is believed that this type of analysis may be used as an early indicator of patients at risk of developing high ICP.

[0038] In accordance with other embodiments of the present invention, the venous pulsations may be quantified by measuring a pressure or an elevation of the patient's head with respect to the patient's heart required to abolish detected venous pulsations. Indeed, such techniques may include applying pressure to the patient's forehead via the sensor or adjusting the patient's upper body to a certain angle to abolish detected venous pulsations. For example, a clinician may block venous pulsations by simply pressing on the sensor or by tightening a headband on the patient's forehead. Pressure measurements between the sensor and the patient may be taken to determine how much pressure was required to overcome the venous pulsations. Specifically, a pressure sheet sensor (e.g., pressure sheet **20**) may be utilized to determine the pressure required to abolish the venous pulsations, and the value of the pressure may be utilized with a predicted correlation to estimate ICP.

[0039] The pressure required to abolish the venous pulsations correlates with ICP because the supraorbital vein on the forehead is in direct communication with the superior ophthalmic vein, which is a tributary to the cavernous sinus (inside the cranial vault). As there are no valves in any of these veins, pressures can be directly transmitted from the cavernous sinus to the supraorbital vein. Indeed, Poiseuille's law states that blood flows within a vessel from point A to point B if there is an intravascular pressure gradient between the two points. As such, pressure differences between the cavernous sinus and the supraorbital pressure will result in a volume flow correlating with the pressure gradient. As previously mentioned, the cardiac cycle results in a rhythmic influx of arterial blood into the cranial vault, and a corresponding pulsatile efflux of the low pressure fluids (venous and cerebral spinal fluid) to minimize any net change in intra-cranial pressure. These venous pulsations can be monitored to provide information regarding intracranial pulse pressure and the corresponding pressure in the CSF (clinical intra-cranial pressure). It should further be noted that as the superior ophthalmic vein enters the crania vault, it passes through the subarachnoid space (the compartment containing the CSF). As the walls of veins lack rigidity, elevations in ICP will eventually result in occlusions of this segment of the vein and will abolish any venous pulsations transmitted to the supraorbital vein in the forehead. This occurs in the clinically important region of 20-25 mmHg, and could therefore be used as an indicator of when to treat.

[0040] In another example, the patient's upper body may be adjusted to an angle such that the patient's head is a certain distance above the patient's heart. This distance or the angle of the patient's body required to stop the venous pulsations may be measured and used with a predicted correlation to estimate ICP. Similar to the description set forth above, altering the volume in the cranial vault will result in associated changes in the venous pulsations of the supraorbital vein. In this case, gravity may be used to change the volume of blood and CSF in the cranial vault, which in turn may have a predictable effect on the venous pulsation.

[0041] As set forth above, block 206 represents determining whether the patient's ICP is elevated based on correlations between characteristics of the venous pulsations and levels of ICP. For example, it is anticipated that if the pressure required to abolish venous pulsation exceeds a predetermined value, such as 20 mmHg, the patient will have an elevated ICP. Similarly, it is anticipated that direct correlations between certain elevations of the patient's head above the patient's heart will indicate that the patient has an elevated ICP. Further, it is anticipated that in some embodiments, an elevated ICP will be discernable from features of the signals relating to venous pulsations. Upon detecting an elevated ICP, embodiments of the present invention may initiate an alarm or automatically deliver pharmaceuticals to the patient to relieve the elevated ICP.

[0042] While the invention may be susceptible to various modifications and alternative forms, specific embodiments have been shown by way of example in the drawings and will be described in detail herein. However, it should be understood that the invention is not intended to be limited to the particular forms disclosed. Rather, the invention is to cover all modifications, equivalents and alternatives falling within the spirit and scope of the invention as defined by the following appended claims.

What is claimed is:

1. A system for monitoring intracranial pressure, comprising:
 - a sensor comprising:
 - an emitter configured to emit at least one electromagnetic wavelength into tissue of a patient; and
 - a detector configured to detect the at least one electromagnetic wavelength after scattering by the tissue;
 - a monitor configured to be in electronic communication with the sensor, the monitor configured to analyze characteristics of the at least one detected electromagnetic wavelength to identify venous pulsations and to determine whether intracranial pressure is elevated in the patient based on correlation only between the venous pulsations and levels of intracranial pressure.
2. The system of claim 1, comprising an adjustment measurement device configured to measure a level of adjustment corresponding to abolishment of identified venous pulsations.
3. The system of claim 1, comprising:
 - an inflatable headband; and
 - a pump configured to inflate the headband to increase pressure between the sensor and the tissue.
4. The system of claim 1, comprising an adjustable head elevator configured to elevate the tissue with respect to the heart of the patient.
5. The system of claim 1, wherein the monitor comprises a pressure mapping system.
6. The system of claim 1, wherein the monitor comprises a pulse oximeter.
7. A monitor for monitoring intracranial pressure, comprising:
 - a processing device configured to:
 - receive, via a sensor, a signal representative of at least one detected electromagnetic wavelength scattered by a forehead tissue of a patient; and
 - analyze characteristics of the signal to identify venous pulsations and to determine whether intracranial pressure is elevated in the patient based on a correlation only between the venous pulsations and levels of intracranial pressure.
8. The monitor of claim 7, wherein the processing device is configured to receive an input representative of an amount of pressure applied to the forehead tissue of the patient that abolishes venous pulsations and to quantify the intracranial pressure based on the amount of pressure applied to the tissue.
9. The monitor of claim 8, wherein the processing device is configured to cause an inflatable headband to adjust an amount of pressure applied to the forehead tissue of the patient.
10. The monitor of claim 7, wherein the processing device is configured to receive an input representative of an angle or level of elevation of the forehead tissue relative to the heart of the patient that abolishes venous pulsations and to quantify the intracranial pressure based on the angle or level of elevation.
11. The monitor of claim 10, wherein the processing device is configured to cause an adjustable head elevator to adjust the angle or level of elevation.
12. The monitor of claim 7, wherein the characteristics include variations in the signal corresponding to a pulse.
13. The monitor of claim 12, wherein the processing device is configured to analyze a shape of the variations to identify the venous pulsations based on a correlation between the shape and the venous pulsations.

14. The monitor of claim 7, wherein the processing device is configured to analyze a phase difference between variations in at least two signals representative of detected electromagnetic wavelengths scattered by the forehead tissue of the patient to identify the venous pulsations based on a correlation between the phase difference and the venous pulsations.

15. The monitor of claim 14, wherein each signal of the at least two signals is obtained from a different portion of the forehead tissue of the patient.

16. The monitor of claim 15, wherein the processing device is configured to compare a ratio of the variations in a first signal of the at least two signals and the variations in a second signal of the at least two signals to identify the venous pulsations based on a correlation between the ratio and the venous pulsations.

17. The monitor of claim 7, wherein the processing device is configured to receive at least two signals representative of detected electromagnetic wavelengths scattered by the forehead tissue of the patient, each signal of the at least two signals is obtained from a different portion of the forehead tissue of the patient, and the processing device is configured to identify the venous pulsations by comparing a first oxygen saturation estimate obtained from a first signal of the at least two signals and a second oxygen saturation estimate obtained from a second signal of the at least two signals.

18. The monitor of claim 7, wherein the processing device is configured to receive an electrocardiogram (ECG) signal of the patient and to compare a phase difference between a pulse of the signal representative of at least one detected electromagnetic wavelength and the ECG signal to identify the venous pulsations.

19. A monitor for monitoring intracranial pressure, comprising:

a processing device configured to:

receive, via a sensor, a signal representative of at least one detected electromagnetic wavelength scattered by a tissue of a patient; and

determine whether venous pulsations are present in the tissue based on the received signal;

if venous pulsations are present, cause adjustment of an adjustment measurement device until venous pulsations cease; and

determine whether intracranial pressure is elevated in the patient based on a correlation only between a level at which venous pulsations cease and a level of intracranial pressure.

20. The monitor of claim 19, wherein the adjustment measurement device comprises a pressure sheet.

* * * * *

专利名称(译)	用于监测颅内压的方法和系统		
公开(公告)号	US20140180046A1	公开(公告)日	2014-06-26
申请号	US14/195535	申请日	2014-03-03
[标]申请(专利权)人(译)	柯惠有限合伙公司		
申请(专利权)人(译)	COVIDIEN LP		
当前申请(专利权)人(译)	COVIDIEN LP		
[标]发明人	CAMPBELL SHANNON E BAKER JR CLARK R		
发明人	CAMPBELL, SHANNON E. BAKER, JR., CLARK R.		
IPC分类号	A61B5/03 A61B5/00 A61B5/0205		
CPC分类号	A61B5/031 A61B5/0205 A61B5/1455 A61B5/6814		
外部链接	Espacenet USPTO		

摘要(译)

本发明的实施例涉及用于监测颅内压的系统和方法。本发明的实施例包括将电磁波长发射到患者的前额组织中，并且在电磁波长被组织散射之后检测电磁波长的特性。特征可以包括对应于脉冲的电磁波长的变化。此外，本发明的实施例包括分析变化以识别静脉脉动，并基于静脉脉动和颅内压水平之间的相关性确定患者的颅内压是否升高。

