



US010524668B2

(12) **United States Patent**
Bernstein

(10) **Patent No.:** **US 10,524,668 B2**
(45) **Date of Patent:** **Jan. 7, 2020**

(54) **METHOD AND APPARATUS FOR DETERMINATION OF LEFT VENTRICULAR STROKE VOLUME AND CARDIAC OUTPUT USING THE ARTERIES OF THE FOREARM BY MEANS OF INTEGRATION TECHNIQUE**

A61B 5/742; A61B 5/681; A63B 24/0062; A63B 71/0619; A63B 22/04; A63B 22/0664; A63B 22/02; A63B 22/0605; A63B 2071/0663; A63B 2220/836; A63B 2230/04; A63B 2225/50; A63B 2024/0065

(71) Applicant: **AEROBEX, INC.**, Rancho Santa Fe, CA (US)

See application file for complete search history.

(72) Inventor: **Donald P. Bernstein**, Rancho Santa Fe, CA (US)

(56) **References Cited**

(73) Assignee: **AEROBEX, INC.**, Rancho Santa Fe, CA (US)

U.S. PATENT DOCUMENTS

(*) Notice: Subject to any disclaimer, the term of this patent is extended or adjusted under 35 U.S.C. 154(b) by 96 days.

4,450,527 A 5/1984 Sramek
5,469,859 A 11/1995 Tsoglin et al.
(Continued)

(21) Appl. No.: **15/889,089**

(22) Filed: **Feb. 5, 2018**

OTHER PUBLICATIONS

K. Beck, et al., "Relationship Between Cardiac Output and Oxygen Consumption During Upright Cycle Exercise in Healthy Humans," J. Appl. Physiol 101:1474-1480, 2006.

(65) **Prior Publication Data**

US 2019/0239756 A1 Aug. 8, 2019

(Continued)

(51) **Int. Cl.**

A61B 5/00 (2006.01)
A61B 5/02 (2006.01)

(Continued)

Primary Examiner — Scott M. Getzow

(74) *Attorney, Agent, or Firm* — DLA Piper LLP (US)

(52) **U.S. Cl.**

CPC **A61B 5/02028** (2013.01); **A61B 5/0245** (2013.01); **A61B 5/681** (2013.01); **A61B 5/7239** (2013.01); **A61B 5/742** (2013.01); **A63B 22/02** (2013.01); **A63B 22/04** (2013.01); **A63B 22/0605** (2013.01); **A63B 22/0664** (2013.01); **A63B 24/0062** (2013.01); **A63B 71/0619** (2013.01); **A63B 2024/0065** (2013.01);

(Continued)

(57) **ABSTRACT**

An apparatus a method for determining stroke volume by bioimpedance from a person having two or more spaced apart alternating current flow electrodes positionable on a person and two or more spaced apart voltage sensing electrodes positionable on the person and between the alternating current flow electrodes. A constant magnitude alternating current source is electrically connectable to the alternating current flow electrodes. A voltmeter is electrically connectable to the voltage sensing electrodes and configured to generate a voltage signal Z from a voltage sensed by the voltage sensing electrodes. A processing unit is electrically connectable with the voltmeter and configured to determine a stroke volume (SV) using the voltage signal Z and at least one of six equations.

(58) **Field of Classification Search**

CPC . A61B 5/02028; A61B 5/0245; A61B 5/7239;

21 Claims, 6 Drawing Sheets

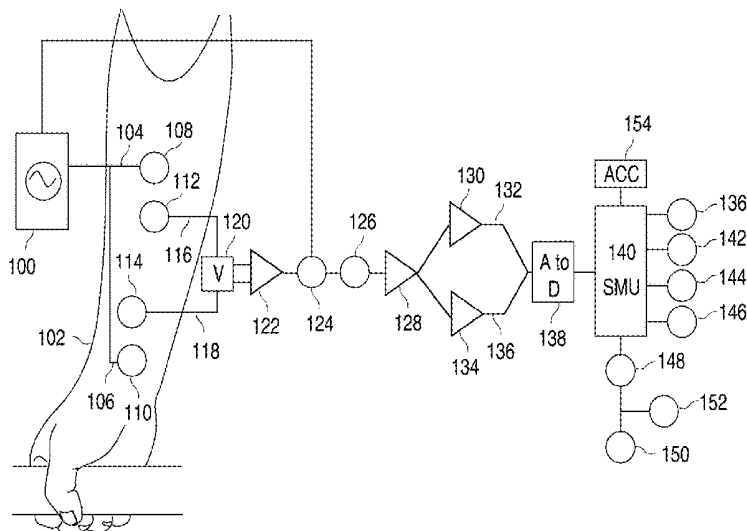

- (51) **Int. Cl.**
A63B 22/06 (2006.01)
A63B 22/02 (2006.01)
A63B 22/04 (2006.01)
A63B 71/06 (2006.01)
A63B 24/00 (2006.01)
A61B 5/0245 (2006.01)
- (52) **U.S. Cl.**
 CPC . *A63B 2071/0663* (2013.01); *A63B 2220/836*
 (2013.01); *A63B 2225/50* (2013.01); *A63B*
2230/04 (2013.01)

(56) **References Cited**

U.S. PATENT DOCUMENTS

5,735,284	A	4/1998	Tsoglin
5,782,774	A	7/1998	Schmulewitz
6,292,689	B1	9/2001	Wallace
6,361,501	B1	3/2002	Amano
6,511,438	B2	1/2003	Bernstein
7,261,697	B2	8/2007	Bernstein
7,740,590	B2	6/2010	Bernstein
7,806,830	B2	10/2010	Bernstein
9,451,888	B1	9/2016	Bernstein
2007/0219059	A1	9/2007	Schwartz

OTHER PUBLICATIONS

Jan Nyboer, "Electrical Impedance Plethysmography," *Circulation*, vol. II, pp. 811-821, Dec. 1950.

Stringer, et al., "Cardiac Output Estimated Noninvasively From Oxygen Uptake During Exercise," *J. Appl. Physiol* 82:908-912, 1997.

Henry, et al., "Stroke Volume Obtained From the Brachial Artery Using Transbrachial Electrical Bioimpedance Velocimetry," *IEEE*, pp. 142-145, 2012.

Lynn, et al., "Arm and Wrist Surface Potential Mapping for Wearable ECG Rhythm Recording Devices: a pilot clinical study," IOP Publishing Ltd., *Sensors & their Applications XVII*, Journal of Physics: Conference Series 450, pp. 1-8, 2013.

Zambanini, et al., "Wave-energy Patterns in Carotid, Brachial, and Radial Arteries: A noninvasive Approach Using Wave-intensity Analysis," *Am J Physiol Heart Circ Physiol* 289, pp. 270-276., Feb. 2005.

Wang, et al., "Development of Forearm Impedance Plethysmography for the Minimally Invasive Monitoring of Cardiac Pumping Function," *J. Biomedical Science and Eng.*, pp. 122-129, 2011.

Bernstein, et al., "Validation of Stroke Volume and Cardiac Output by Electrical Interrogation of the Brachial Artery . . . Error," *Journal of Clinical Monitoring and Computing*, ISSN 1387-1307, Feb. 2015.

Bernstein, et al., "Stroke Volume Obtained by Electrical Interrogation of the Brachial Artery . . . Velocimetry," *Institute of Physics and Eng. In Medicine, Physiol. Meas.* 33, pp. 629-649, 2012.

Rodriguez, et al., "Non-invasive Estimate of Cardiac Output During Exercise Based on Impedance Cardiography and Oxygen Uptake in the Elderly," *Arq Bras Cardiol* 2007; 88(1): pp. 71-75.

Chemla, et al., "Blood Flow Acceleration in the Carotid and Brachial Arteries . . . Resistance," *Fundamental & Clinical Pharmacology* 1996:10: pp. 393-399.

Weissler, et al., "Systolic Time Intervals in Heart Failure in Man," *Circulation*, vol. XXXVII No. 2, pp. 149-159, 1968.

Lepretre, et al., "Effect of Exercise Intensity on Relationship Between . . . Output," *American College of Sports Medicine*, pp. 1357-1363, 2004.

Goncalves, et al., "Non-contact Wearable Single Forearm Cardiac Biopotential Acquisition Device," *Journal of Physics: Conference Series* 459, pp. 1-6, 2013.

Targett, et al., "Simultaneous Doppler Blood Velocity Measurements . . . Subjects," *Cardiovascular Research*, pp. 394-399, 1985.

Wang, et al., "Evaluation of Changes in Cardiac Output From the Electrical . . . Forearm," *Physiol Meas.* 28, IOP Publishing, pp. 989-999, 2007.

Bernstein, "Impedance Cardiography: Pulsatile Blood Flow and the Biophysical . . . Equations," *Journal of Electrical Bioimpedance*, vol. 1, pp. 2-17, 2010.

Bassett, et al., "Limiting Factors for Maximum Oxygen Uptake and . . . Performance," *Medicine & Science in Sports & Exercise*, pp. 70-84, 2000.

Bernstein, et al., "Stroke Volume Equation for Impedance Cardiography," *Medical & Biological Engineering & Computing*, vol. 43, pp. 443-450, 2005.

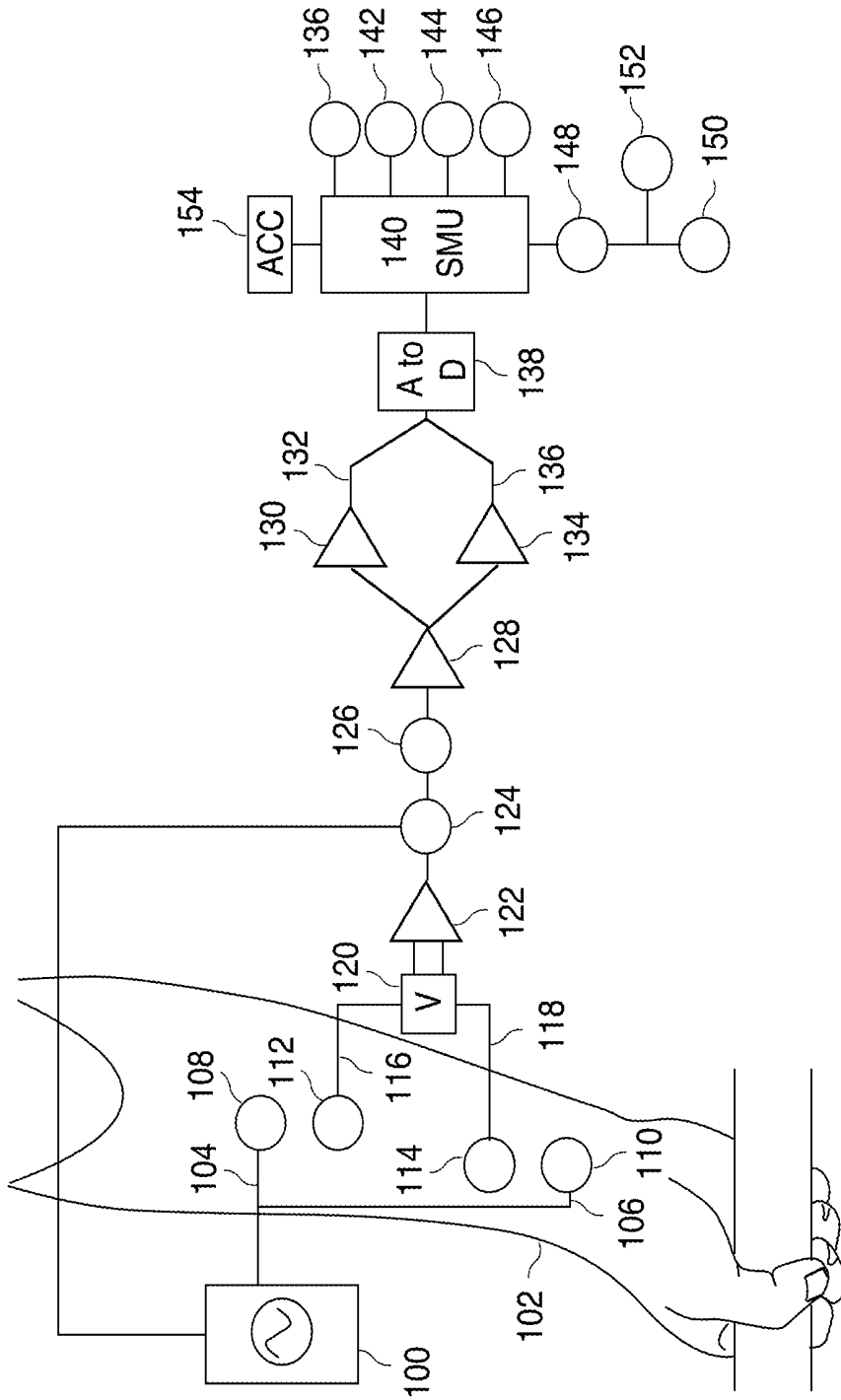

FIG. 1

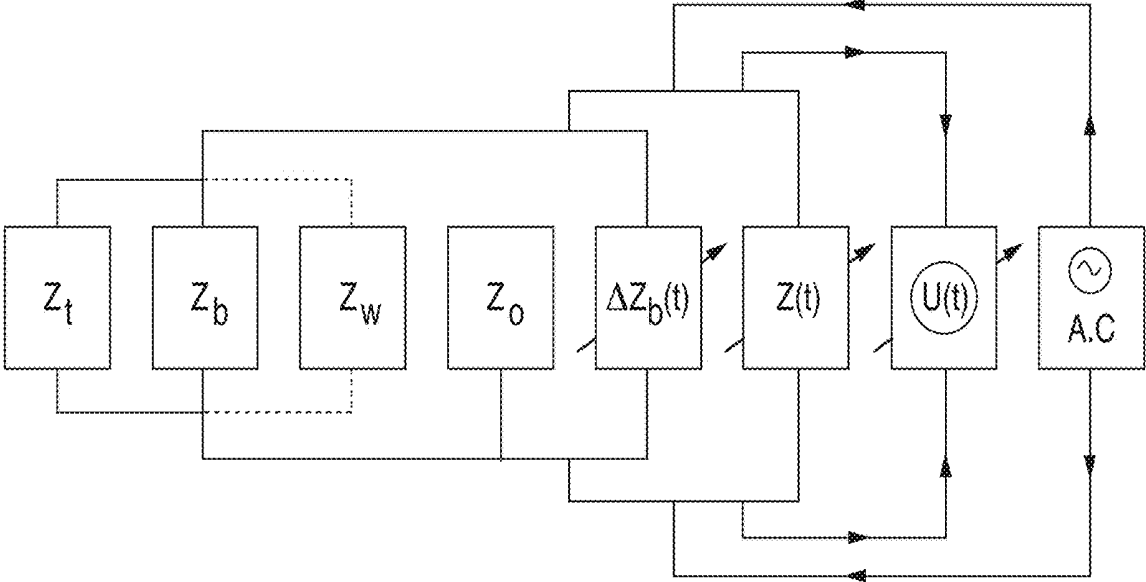

FIG. 2

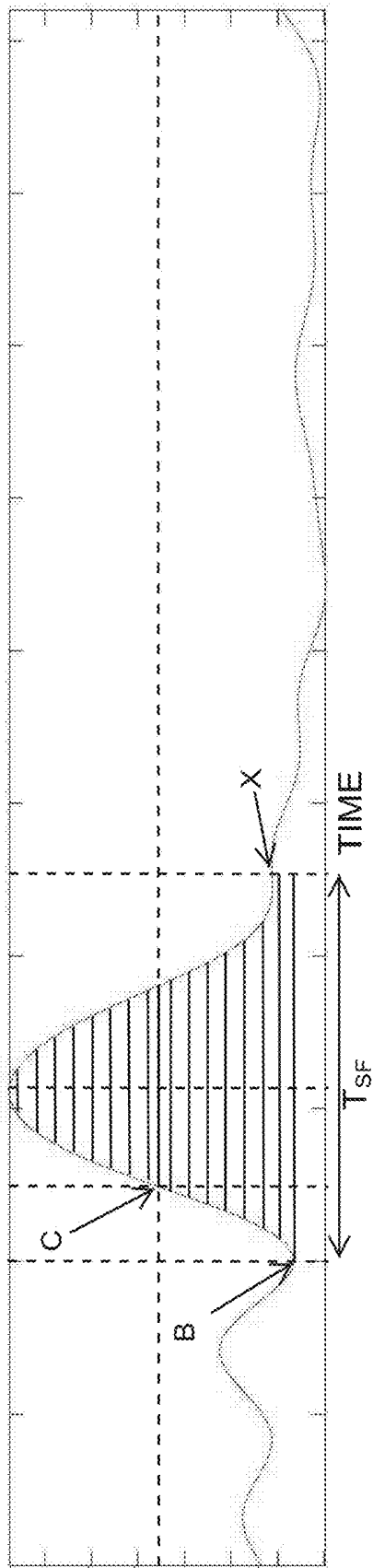

FIG. 3A

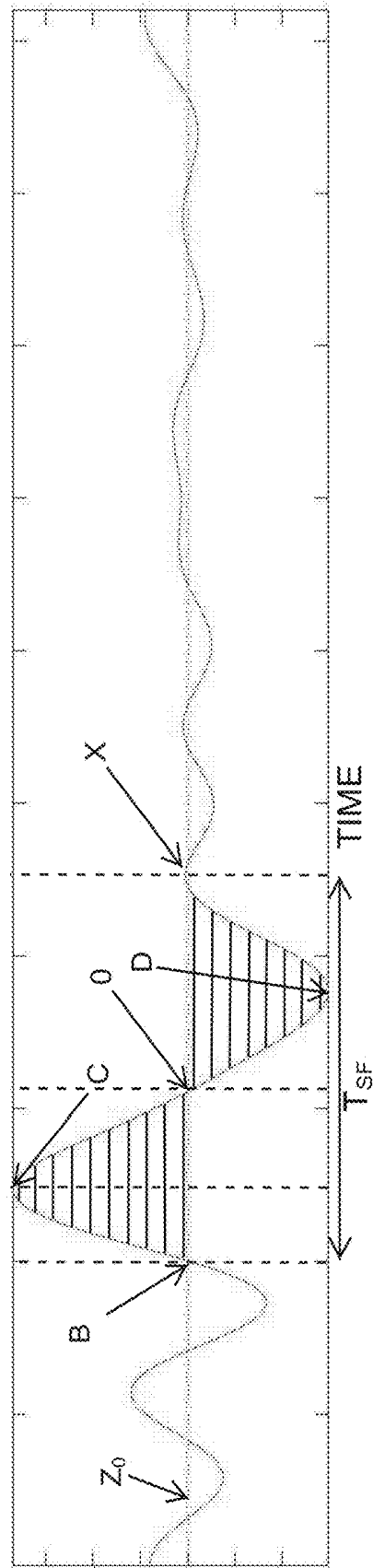

FIG. 3B

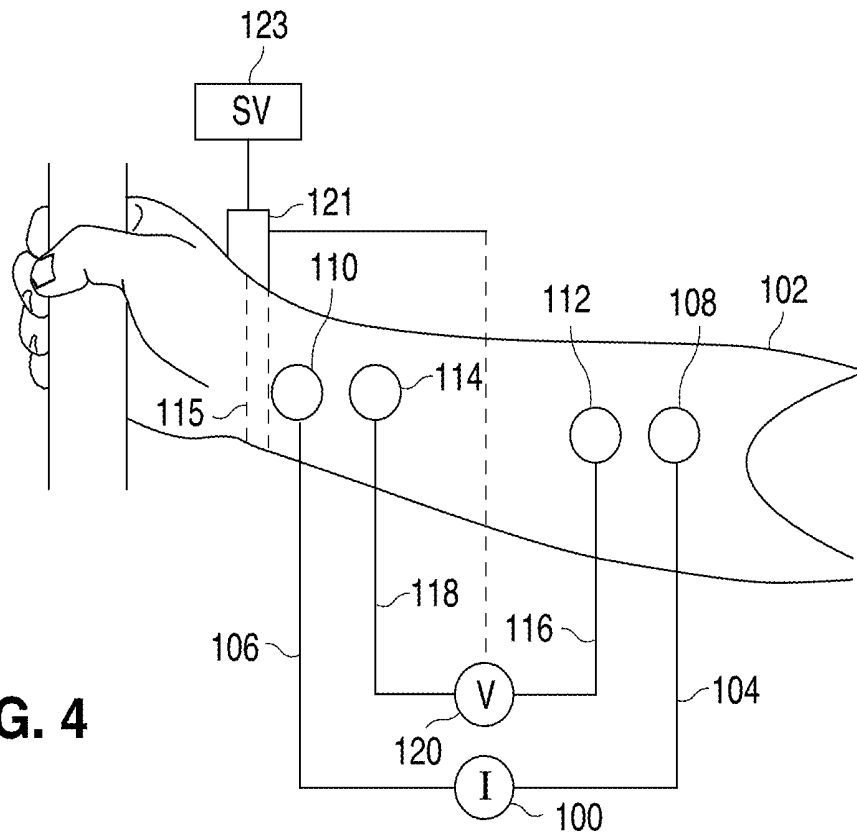

FIG. 4

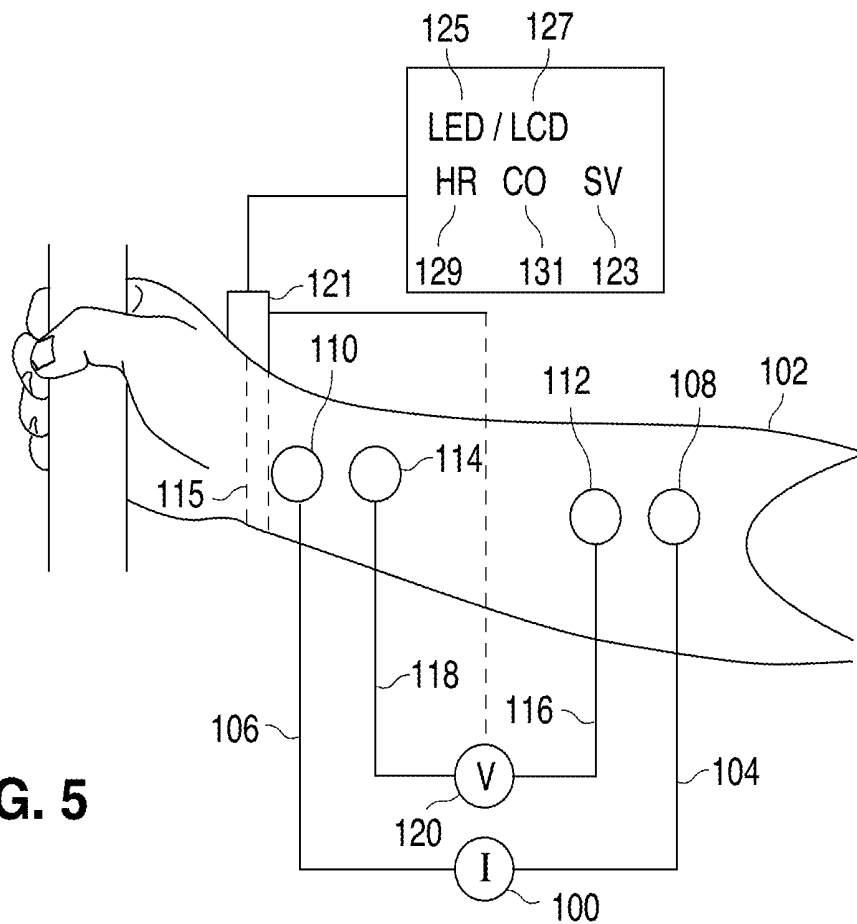
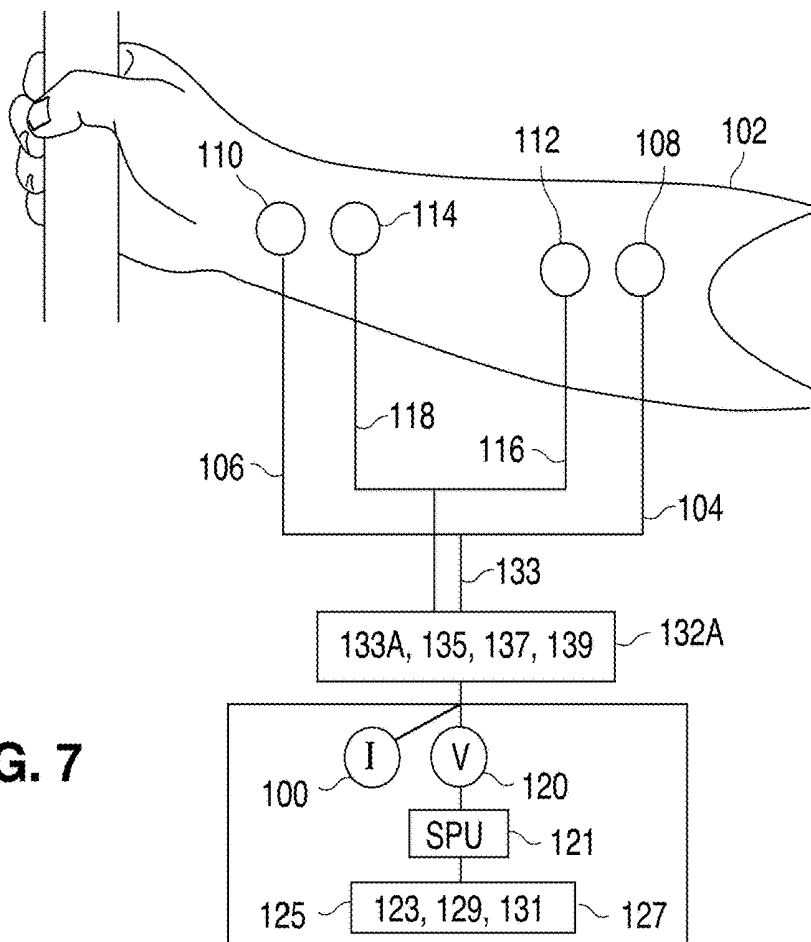
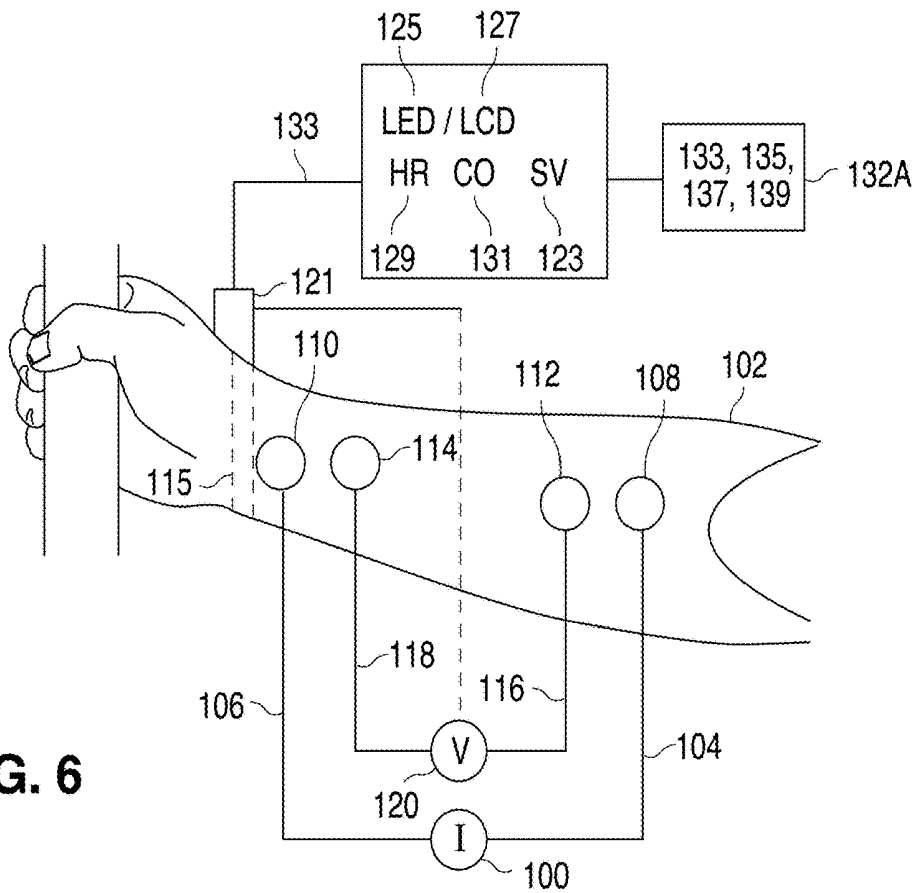

FIG. 5



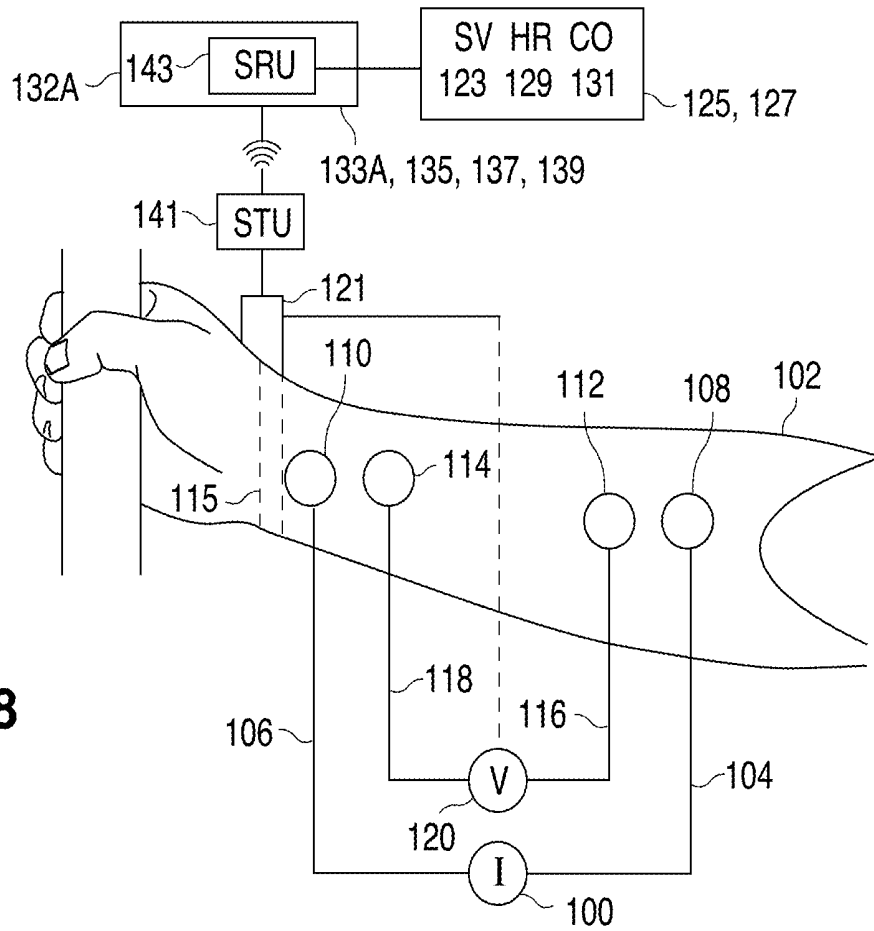

FIG. 8

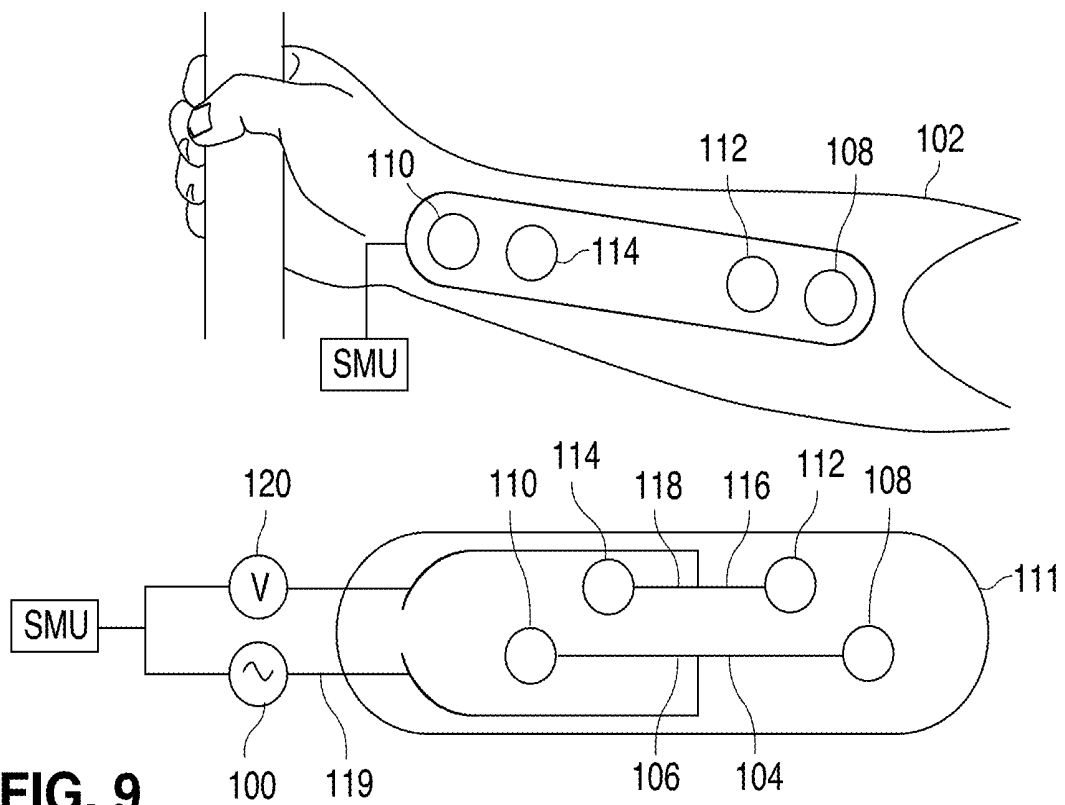

FIG. 9

**METHOD AND APPARATUS FOR
DETERMINATION OF LEFT VENTRICULAR
STROKE VOLUME AND CARDIAC OUTPUT
USING THE ARTERIES OF THE FOREARM
BY MEANS OF INTEGRATION TECHNIQUE**

FIELD OF THE INVENTION

This present invention relates to the determination of the volumetric output of the left ventricle of a person's heart per beat, otherwise known as stroke volume (SV), measured in milliliters (mL), and the volumetric output of the left ventricle of a person's heart per minute, known as cardiac output (CO), measured in liters per minute ($L \cdot \text{min}^{-1}$). More particularly, this invention relates to the determination of SV and CO by transradial-ulnar electrical (bioimpedance) velocimetry (TRUBEV) by means of integration technique.

BACKGROUND OF THE INVENTION

All methods, apparatus, and inventions related to the measurement of SV/CO by the electrical bioimpedance method have heretofore been implemented by means of:

Transthoracic method, known as transthoracic electrical bioimpedance cardiography, or impedance cardiography (ICG), U.S. Pat. No. 4,450,527 A.

Transthoracic electrical (bioimpedance) velocimetry, U.S. Pat. No. 6,511,438 B2.

Total or whole body electrical bioimpedance plethysmography method, also known as total (whole) body electrical bioimpedance cardiography, U.S. Pat. Nos. 5,469,859, 5,735,284.

Transbrachial electrical (bioimpedance) velocimetry, U.S. Pat. No. 7,261,697, B2, U.S. Pat. No. 7,740,590 B2, U.S. Pat. No. 7,806,830 B2.

Method and Apparatus for Determination of Left Ventricular Stroke Volume and Cardiac Output Using the Arteries of the Forearm, U.S. Pat. No. 9,451,888 B1
Endotracheal cardiac output, U.S. Pat. Nos. 5,782,774, 6,292,689.

Apart from the transthoracic and transbrachial velocimetric techniques, all prior methods ascribe a pure volumetric origin for the time-dependent primary impedance change $\Delta Z(t)$ (ohm, Ω) and its peak time rate of change (first time-derivative) $dZ(t)/dt_{max}$, originally thought to be measured in $\Omega \cdot \text{s}^{-1}$. The two most widely used methods ascribing a volumetric (plethysmographic) etiology for both $\Delta Z(t)$ and dZ/dt_{max} include the Nyboer-Kubicek and Sramek-Bernstein techniques, which differ with respect to their individual spot or band-electrode configurations on the thorax (chest) and their respective SV equations (Bernstein et al. Stroke volume equation for impedance cardiography. *Med Biol Eng Comput* 2005; 43:443-50; Bernstein D P, Impedance Cardiography: Pulsatile blood flow and the biophysical and electrodynamic basis for the stroke volume equations. *J Electr Bioimp.* 2010; 1:2-7) and as disclosed in Bernstein et al. U.S. Pat. No. 6,511,438 B2).

The aforementioned bioimpedance methods have been implemented for a variety of medical and non-medical purposes:

Determination of CO in sick hospitalized patients.

Cardiac pacemaker resynchronization therapy.

Cardiac rehabilitation for post myocardial infarction and heart failure patients.

Exercise physiology using the transthoracic methods.

Efficacy of intense aerobic training as a surrogate for maximal oxygen consumption.

Effect of medications on the cardiovascular system.

Studies involving the radial/ulnar arteries of the forearm include:

Nyboer (Nyboer J. Electrical impedance plethysmography; a physical and physiologic approach to peripheral vascular study. *Circulation* 1950; 2:811-21) demonstrated that electrical impedance changes (ΔZ) of the forearm correlated with volumetric strain gauge approximations of volume changes in the vessels of the forearm.

Wang et al. (Wang et al. Evaluation of changes in cardiac output from electrical impedance changes of the forearm. *Physiol Meas.* 2007; 28:989-99) and Wang et al. (Wang et al. Development of forearm impedance plethysmography for minimally invasive monitoring of cardiac pumping function. *Journal of Biomechanical Science and Engineering.* 2011; 14:122-29) demonstrated that, the change in magnitude and percent change in the magnitude of forearm of ΔZ and the change in magnitude and percent change in area beneath the ΔZ were highly correlated with the change in magnitude and percent change in magnitude of measured stroke volume (SV). Neither the magnitude of ΔZ or area beneath the ΔZ waveform correlated well with measured SV.

Targett et al. (Targett R et al. Simultaneous Doppler blood velocity measurements from the aorta and radial artery in normal human normal subjects. *Cardiovasc Res.* 1985; 19:394-399) demonstrated that peak radial artery blood acceleration has a constant relationship with peak aortic blood acceleration, regardless of age.

Chemla et al. (Chemla et al. Blood flow acceleration in the carotid and brachial arteries of healthy volunteers: respective contributions of cardiac performance and local resistance. *Fundam Clin Pharmacol* 1996; 10:393-99) noted that peak brachial artery and peak radial artery acceleration were of similar magnitudes.

Zambanini et al. (Zambanini et al. Wave energy in carotid, brachial and radial arteries: a noninvasive approach using wave intensity analysis. *Am J Physiol Heart Circ Physiol.* 2005; 289:H270-H276) demonstrated that the magnitude of brachial and radial artery velocities and peak slope of the velocity waveforms were nearly identical.

BRIEF SUMMARY OF THE INVENTION

It has been discovered that SV can be obtained from the radial artery with equivalent accuracy as that of the transbrachial approach. Bernstein et al. Stroke volume obtained by electrical interrogation of the brachial artery: transbrachial electrical bioimpedance velocimetry. *Physiol Meas* 2012; 33:629-49, Bernstein et al. Validation of stroke volume and cardiac output by electrical interrogation of the brachial artery in normals; assessment of strengths, limitations, and sources of error. *J Clin Monit Comput* 2015; 15 Feb. 2015 [Epub ahead of print], *J Clin Monit Comput* 2015; 29:789-800. The studies, especially those of Wang et al and Wang et al (vide supra) did not investigate the correlation of absolute SV with the peak first time-derivative of forearm ΔZ , namely, forearm dZ/dt_{max} . They, therefore, were unable to transform dZ/dt_{max} , an acceleration analog, to ohmic mean velocity, which is necessary for SV determination (Bernstein et al. Stroke volume equation for impedance cardiography. *Med Biol Eng Comput* 2005; 43:443-50).

Absolute SV cannot be determined by implementation of un-signal processed ΔZ , and, for the purposes of the present invention, dZ/dt .

While the present invention would be appropriate for any of the above implementations, it is specifically designed, but not limited to use in aerobic fitness training, such as with a stationary exercise bicycle, elliptical pedaling device, treadmill, or any other stationary exercise machines. Cardiac output is a useful monitoring variable in assessing aerobic fitness, because it virtually parallels oxygen consumption (VO_2). Maximum oxygen consumption ($VO_{2\ max}$), the holy grail of aerobic cardiorespiratory fitness, is near-linearly related to maximum cardiac output. Maximum cardiac output, in turn, is the ultimate expression of cardiovascular performance. (Cooke G A et al. Physiologic reserve: development of a noninvasive method and first estimates in man. *Heart* 1998; 79:289-294; Beck K C et al. Relationship between cardiac output and oxygen consumption during upright cycle exercise in healthy humans. *J Appl Physiol* 2006; 101:1474-1480; Rodrigues M N, et al. Noninvasive estimate of cardiac output during exercise-based on impedance cardiography and oxygen uptake in the elderly. *Arq Bras Cardiol* 2007; 88:71-75; Lepretre P M et al. Effect of exercise intensity on relationship between $VO_{2\ max}$ and cardiac output. *Sci Med Sports Exerc* 2004; 36:1357-1363; Bassett D R et al. Limiting factors for maximum oxygen uptake and determinants of endurance performance. *Med Sci Sports Exerc* 2000; 32:70-84.) Advantages of obtaining stroke volume and cardiac output from arteries of the forearm, namely from the radial and ulnar arteries, considered in the aggregate, include the following:

Less motion of forearm than that of the thorax or upper arm when used with a stationary exercise bicycle with fixed handlebars, an elliptical pedaling device, or treadmill with stationary arm rests, therefore producing less motion signal artifact.

Electrodes on forearm are more easily placed and affixed by user-subject than either the transthoracic or upper arm transbrachial electrode configurations.

Electrodes on forearm are more closely tethered directly by electric cable or wirelessly to a signal acquisition and processing module on the wrist or a signal acquisition and processing module directly connected to a peripheral devices, such as a stationary bicycle, treadmill, elliptical pedaling device, or any other exercise device in contact with the subject.

The onset of flow, otherwise known as point B on dZ/dt , is more easily identified than that from the transthoracic bioimpedance methods. End of flow, otherwise known as point X, is more easily identified than from either the transthoracic or transbrachial methods.

Forearm applications of the velocimetric bioimpedance technique are affected less by respiratory variations in ΔZ , the primordial impedance change, and its peak time rate of change, transradioulnar dZ/dt_{max} , in comparison with the chest (thorax) or upper arm (brachium).

Forearm impedance changes will not be affected by excess intrathoracic, extravascular lung water (pulmonary edema) or peripheral lower arm edema, when used in the intended healthy population.

Exemplary waveforms of FIG. 3B, obtained from the forearm in healthy humans, allow precise identification of point B (onset of flow) and the second Z_0 crossing after dZ/dt_{max} (point X, termination of flow), the temporal interval separating the two points, representing

systolic flow time (SFT, s), which is equivalent in magnitude to left ventricular ejection time (LVET, T_{LVE} , s).

The primordial impedance pulse variation, $\Delta Z(t)$, otherwise known as $dZ(t)$, is generated by changes in velocity-induced variations in erythrocyte orientation, causing changes in blood resistivity $d\rho_b(t)$ and its rate of change, $d\rho_b(t)/dt$. Virtual lack of a significant diameter change of the radial artery indicates that the areas beneath the impedance pulse envelopes can be integrated by electronic planimetry. Unlike the bulk of earlier empirical techniques, this new method can be explained by rational biophysical statements, which are founded on extrapolations of the classical physics of motion.

The present invention is an apparatus and method for determining stroke volume (SV) by bioimpedance from a person using two or more spaced apart alternating current flow electrodes positionable on a person, two or more spaced apart voltage sensing electrodes positionable on the person and between the alternating current flow electrodes, a constant magnitude alternating current source electrically connectable to the alternating current flow electrodes, and a voltmeter electrically connectable to the voltage sensing electrodes and configured to generate a voltage signal Z from a voltage sensed by the voltage sensing electrodes. The apparatus includes a processing unit electrically connectable with the voltmeter and configured to determine a stroke volume (SV) using the voltage signal Z and at least one of the following six equations, or the method determines a stroke volume (SV) using the voltage signal Z and at least one of the following six equations:

$$\dot{Q}_Z = C \cdot \frac{\left[\int_{t_B}^{t_0} \frac{dZ(t)}{dt} dt + \int_{t_0}^{t_X} \left| -\frac{dZ(t)}{dt} dt \right| \right]}{Z_0} = C \cdot \frac{dZ(t)_{total}}{Z_0} \quad (1)$$

$$\dot{Q}_Z = C \cdot \frac{+dZ(t) + |-dZ(t)|}{Z_0} = C \cdot \frac{dZ(t)_{total}}{Z_0} \quad (2)$$

$$SV_Z = C \cdot \frac{\left[\int_{t_B}^{t_0} +dZ(t)dt + \int_{t_0}^{t_X} |-dZ(t)dt \right]}{Z_0} = C \cdot \frac{[+Z + |-Z|]}{Z_0} \quad (3)$$

$$SV_Z = C \cdot \frac{[+Z + |-Z|]}{Z_0} = C \cdot \frac{Z_{total}}{Z_0} \quad (4)$$

$$SV_Z = Q = C \cdot \frac{\int_{t_B}^{t_X} dZ(t)dt_{total}}{Z_0} = C \cdot \frac{Z_{total}}{Z_0} \quad (5)$$

$$SV_Z = C \cdot \frac{\int_{t_B}^{t_X} dZ(t)dt}{Z_0} = C \cdot \frac{Z}{Z_0} \quad (6)$$

wherein:

\dot{Q}_Z =impedance-derived blood flow velocity (mL/s)
 \int =definite integral over time intervals from t_B to t_0 and t_0 to t_X that collectively are a systolic flow time, where t_B is a beginning point of cardiogenically-induced transradioulnar impedance pulse, t_0 is a maximum point of cardiogenically-induced transradioulnar impedance pulse, and t_X is an ending point of cardiogenically-induced transradioulnar impedance pulse

$$\frac{dZ(t)}{dt} = \text{cardiogenically-induced rate of change}$$

-continued

of the transradioulnar impedance pulse variation

$\frac{dZ(t)}{dt_{max}}$ = peak rate of change of

the cardiogenically-induced transradioulnar

impedance pulse variation

$dZ(t)$ =cardiogenically-induced transradioulnar impedance pulse variation

C=constant person-specific mass-based allometric equivalent of volume

Q_Z =transradioulnar impedance-derived stroke volume

Z_0 =quasi-static transradioulnar base impedance.

Other objects and features of the present invention will become apparent by review of the specification, claims and appended figures.

BRIEF DESCRIPTION OF THE DRAWINGS

The drawings accompanying and forming part of this specification are included to depict certain aspects of the invention. A clearer concept of the invention and of the components of the operation of systems provided with the invention, will become more readily apparent by referring to the exemplary, and therefore nonlimiting, embodiments illustrated in the drawings, wherein identical reference numerals or letters (i.e. A, B, C, etc.) designate the same components. The invention may be better understood by reference to one or more of these drawings in conjunction with the description presented herein. It should be noted that the features illustrated in the drawings are not necessarily drawn to scale.

FIG. 1 is a plan view showing the stroke volume and cardiac output apparatus as applied to the person's forearm.

FIG. 2 is a schematic drawing of the transradioulnar impedance (Z(t)).

FIGS. 3A and 3B are drawings with waveforms showing ΔZ and dZ/dt .

FIG. 4 is a plan view showing the current flow electrodes applied to the person's forearm.

FIG. 5 is a plan view showing the current flow electrodes applied to the person's forearm, and an LED/LCD output display.

FIG. 6 is a plan view showing the current flow electrodes applied to the person's forearm, and an LED/LCD output display and exercise machine.

FIG. 7 is a plan view showing the current flow electrodes applied to the person's forearm, and an output display of an exercise machine.

FIG. 8 is a plan view showing the current flow electrodes applied to the person's forearm, and a wireless connection to an output display of an exercise machine.

FIG. 9 is a plan view showing the current flow electrodes applied to the person's forearm in the form of an adhesive carrying strip.

DETAILED DESCRIPTION OF THE INVENTION

An apparatus for determining stroke volume by bioimpedance from a person can include two or more spaced apart alternating current flow electrodes positionable on a person, two or more spaced apart voltage sensing electrodes positionable on the person and between the alternating current flow electrodes, an alternating current source electrically

connectable to the alternating current flow electrodes, a voltmeter electrically connectable to the voltage sensing electrodes and configured to generate a voltage signal from a voltage sensed by the voltage sensing electrodes and a processing unit electrically connectable with the voltmeter and configured to determine a stroke volume (SV) using the voltage signal and at least one of the following equations specifically related to the acceleration curve dZ/dt of FIG. 3B. First, however, a biophysical basis for the impedance equations is obligatory. In the general sense, the rationale derives from the formula of the area of a biphasic sine wave:

$$A = \int_{\pi/4}^0 (+\sin x)dx + \int_0^{\pi/6} |(-\sin x)|dx \tag{Equation 1}$$

The interval of $+\sin x$ is between $\pi/4$ and 0 and the interval of $|-\sin x|$ is between 0 and $\pi/6$. Bracketed $-\sin x$ is the absolute value of $-\sin x$, which is $+\sin x$. If the absolute value of $-\sin x$ was not applied, A would equal 0 (zero).

More specifically for area (A) integration of a biphasic sinusoidal curve, such as dZ/dt , the following example pertains:

$$A = \int_a^b f(x)dx + \int_b^c |-f(x)|dx \tag{Equation 2}$$

where $f(x)$ is the positive concave downward curve above the baseline is added positively to the absolute value of $-f(x)$, the concave upward portion of the dZ/dt curve. It should be understood that to solve the solution for SV, several integrative steps are required. They are analogous and consistent with abstractions of the physics of motion, extrapolated for use in cardiovascular dynamics. Consider the following: if interrogating the behavior of blood flowing through the area of an orifice, such as the aortic valve, and the radius r remains constant through the whole ejection phase, the following equations pertain:

Acceleration of blood flow \dot{Q} is given as follows:

$$\dot{Q} = \pi r^2 \frac{dv(t)}{dt} = \pi r^2 \frac{d^2S(t)}{dt^2} = mL \cdot s^{-2} \tag{Equation 3}$$

Where

v=velocity (cm·s⁻¹)

dv(t)/dt=acceleration (cm·s⁻²)

s=distance (cm)

d²S/dt²=acceleration (cm·s⁻²)

πr^2 =aortic valve cross-sectional area (cm²)

mL·s⁻² indicates the units are milliliters per seconds squared

Blood flow velocity (mL·s⁻¹)Q is the integral of blood flow acceleration \dot{Q} (mL·s⁻²):

$$\dot{Q} = \pi r^2 \int_{t_{avo}}^{t_{ave}} \frac{dv(t)}{dt} dt = \pi r^2 dv(t) = mL \cdot s^{-1} \tag{Equation 3a}$$

Equivalently,

$$\dot{Q} = \pi r^2 \int_{t_{avo}}^{t_{ave}} \frac{d^2S(t)}{dt^2} dt = \pi r^2 \frac{dS(t)}{dt} = mL \cdot s^{-1} \tag{Equation 4}$$

Stroke volume (SV) Q is the integral of velocity of flow, or rate of change of distance:

$$Q = SV = \pi r^2 \int_{t_{avo}}^{t_{avc}} dv(t)dt = \pi r^2 \int_{t_{avo}}^{t_{avc}} \frac{dS(t)}{dt} dt = \pi r^2 S = mL \quad \text{Equation 5}$$

The integrals within equation 5 represent time velocity integrals, otherwise known as systolic velocity integrals (S, cm) in the techniques of both Doppler velocimetry and electromagnetic flowmetry (Bernstein D P. Impedance cardiography: pulsatile blood flow and the biophysical and electrodynamic basis for the stroke volume equations. Journal of Electrical Bioimpedance. vol 1, pp 2-17, 2010).

Here, avo is equal to aortic valve opening and avc is equal to aortic valve closure, and the time interval between the two fiducial landmarks is known as left ventricular ejection time (LVET, s)), hereafter, for this technique, is designated as systolic flow time (SFT).

The apparatus can calculate the following equations, which represent an extrapolation of the classical physics of motion (vide supra) for determining SV as per iterative equations 9 through 14 (vide infra).

Referring to FIG. 3B, the following results are found using $dZ(t)/dt$ (ohms/s², $\Omega \cdot s^{-2}$), the rate of change of the transradioulnar $dZ(t)$ (i.e. $\Delta Z(t)$, ΔZ) and Z_0 , the transradioulnar quasi-static base impedance (Z_0 , ohm, Ω). Accordingly, the apparatus can calculate the acceleration of blood flow by the following method.

$$\ddot{Q}_Z = C \cdot \frac{+\frac{dZ(t)}{dt}}{Z_0} + C \cdot \frac{\left| -\frac{dZ(t)}{dt} \right|}{Z_0} = C \cdot \frac{\left[+\frac{dZ(t)}{dt} + \left| -\frac{dZ(t)}{dt} \right| \right]}{Z_0} = mL \cdot s^{-2} \quad \text{Equation 6}$$

Where the absolute value of $\left| -\frac{dZ(t)}{dt} \right| = +\frac{dZ(t)}{dt} = \Omega \cdot s^{-2}$

For all $+dZ/dt$, the area bounded by the +perimeter of the superior impedance envelope and baseline Z_0 , $+dZ/dt$ may be \geq the absolute value of $-dZ/dt$. For all absolute values of $-dZ/dt$, the area bounded by the -perimeter of the inferior impedance envelope and baseline, Z_0 , the absolute value of $-dZ/dt$ may be $\geq +dZ/dt$.

For FIG. 3B, the positive (+) concave downward portion of the dZ/dt curve is added positively to the absolute value of the negative (-) concave upward portion of the dZ/dt curve below the baseline Z_0 .

$$\ddot{Q}_Z = mL \cdot s^{-2} \quad \text{Equation 7}$$

where:

\ddot{Q}_Z =Impedance-derived acceleration of blood flow (in units of mL/s²)

C=A constant person-specific mass-based (kg) allometric equivalent of volume (mL)

$\frac{dZ(t)}{dt}$ = Rate of change,
or first time-derivative of the cardiogenically-induced

transradioulnar impedance pulse variation. ($\Omega \cdot s^{-2}$)

Z_0 =Transradioulnar quasi-static base impedance (Ω , ohm) between the voltage-sensing electrodes
And simplifying,

$$\dot{Q}_Z = C \cdot \frac{\left[\frac{dZ(t)}{dt} \right]_{TOTAL}}{Z_0} = mL \cdot s^{-2} \quad \text{Equation 8}$$

For equations 1 and 2 and all subsequent equations 6 through 12, the positive (+) and negative (-) signs denote the superior (concave downward) and inferior (concave upward) areas of the sinusoidal curves, respectively. Reiterating, the following equations containing a $-dZ/dt$ term will be added as $+dZ/dt$. The apparatus can therefore calculate the velocity of blood flow, \dot{Q} , by the following method,

$$\dot{Q}_Z = C \cdot \frac{\left[\int_{t_B}^{t_0} +\frac{dZ(t)}{dt} dt \right]}{Z_0} + C \cdot \frac{\left[\int_{t_0}^{t_X} \left| -\frac{dZ(t)}{dt} \right| dt \right]}{Z_0} = mL \cdot s^{-1} \quad \text{Equation 9}$$

where:

\dot{Q}_Z =Impedance-derived velocity of blood flow (with mLs⁻¹ indicating the units are in milliliters per second
f=definite integral of area bounded within the impedance curve and Z_0 over time intervals t_B to t_0 and t_0 to t_X

And simplifying,

$$\dot{Q}_Z = C \cdot \frac{\left[\int_{t_B}^{t_0} +\frac{dZ(t)}{dt} dt + \int_{t_0}^{t_X} \left| -\frac{dZ(t)}{dt} \right| dt \right]}{Z_0} = C \cdot \frac{dZ(t)_{total}}{Z_0} \quad \text{Equation 10}$$

where, $dZ(t)$ represents the velocity of blood flow, which is analogous to $dv(t)$ of equations 3 and 3a.

$$\dot{Q}_Z = C \cdot \frac{+dZ(t) + |-dZ(t)|}{Z_0} = C \cdot \frac{dZ(t)_{total}}{Z_0} \quad \text{Equation 11}$$

The apparatus can calculate SV, which is the integral of flow, by the following method:

$$SV_Z = C \cdot \frac{\left[\int_{t_B}^{t_0} +dZ(t)dt + \int_{t_0}^{t_X} |-dZ(t)dt| \right]}{Z_0} = C \cdot \frac{[+Z + |-Z|]}{Z_0} \quad \text{Equation 12}$$

$$SV_Z = C \cdot \frac{[+Z + |-Z|]}{Z_0} = C \cdot \frac{Z_{total}}{Z_0} \quad \text{Equation 13}$$

where $C \cdot Z_{total}/Z_0$ is analogous and equivalent to $\pi r^2 S$ of the right hand side of equation 5.

And finally, simplifying the LHS of equation 12, SV is thus given as;

$$SV_Z = Q = C \cdot \frac{\int_{t_B}^{t_X} dZ(t)dt_{total}}{Z_0} = C \cdot \frac{Z_{total}}{Z_0} \quad \text{Equation 14}$$

where Z_{total} is the aggregate sum of the numerator of equation 12. More specifically, where "total" means the aggregate flow from the positive sinusoid above Z_0 , and the negative sinusoid below Z_0 .

Referring to FIG. 3B, $dZ(t)$ and its differential $dZ(t)/dt$, below, C represents a constant, person-specific, mass-based allometric equivalent of volume, $+dZ/dt$ represents the +(superior, concave downward) portion of the sine wave from point B to point 0, $-dZ/dt$ represents the negative (-) (inferior, concave upward) portion of the curve from point 0 to point X. $-dZ/dt$ is added positively to $+dZ/dt$. Z_0 is the quasi-static base impedance of the segment between the voltage sensing electrodes of the forearm. Integrating $+dZ/dt$ and adding the absolute value of $-dZ/dt$ yields $dZ(t)$. Integrating $+dZ(t)$ and the absolute value of $-dZ(t)$ yields SV (equations 10, 12, and 13).

Alternatively, and referring to FIG. 3A, the apparatus can compute SV by integrating $dZ(t)$ directly from the $\Delta Z(t)$ waveform. Hence,

$$SV = C \cdot \frac{\int_{t_B}^{t_X} dZ(t)dt}{Z_0} = C \cdot \frac{Z}{Z_0} \tag{Equation 15}$$

In order to determine the person-specific volumetric constant C (which is indicative of the person's volume), the apparatus can calculate SV by means of the following equation from U.S. Pat. No. 9,451,888 B1, which is incorporated solely to calibrate person-specific volumetric constant C:

$$SV = [a^n W^b] \cdot \left[\frac{k_1 k_2}{(dZ(t)/dt_{max} \cdot Z_0^1)^{0.5}} \right] \cdot \left[\frac{dZ(t)/dt_{max}}{Z_0} \right] \cdot T_{SF} \tag{Equation 16}$$

where $dZ(t)/dt_{max}$ is the peak rate of change of the cardio-genically-induced transradioulnar impedance pulse variation ($\Omega \cdot s^2$). The term a is at least 5 and no greater than 10, n is at least 2 and no greater than 4, W is the person's weight, b is at least 1 and no greater than 2, $k_1 \cdot k_2$ collectively are a dimensionless constant at least 0.04 and no greater than 0.3, dZ/dt_{max} is a peak time rate of change of a transradioulnar impedance pulse variation, Z_0 is a transradioulnar quasi-static base impedance, T_{SF} is a systolic flow time, and $a^n W^b$ is a volumetric personal constant.

A further description of variables for equation 16 are defined as disclosed in U.S. Pat. No. 9,451,888 B1, which is incorporated herein by reference for all purposes. The apparatus can calculate C, the person-specific volumetric constant, which is a function of a person's body mass, and is given as follows;

$$C = \left[\frac{[a^n W^b] \cdot \left[\frac{k_1 k_2}{(dZ(t)/dt_{max} \cdot Z_0^1)^{0.5}} \right] \cdot \left[\frac{dZ(t)/dt_{max}}{Z_0} \right] \cdot T_{SF}}{\frac{\int_{t_B}^{t_X} dZ(t)dt}{Z_0}} \right]$$

where the numerator of equation 17 is as disclosed in U.S. Pat. No. 9,451,888 B1. For Systolic flow time (SFT), point B to point X, for equation 15, SFT is preferably measured from the point B to point X of the lower acceleration waveform, dZ/dt in FIG. 3B.

It should be appreciated that the stroke volume equations 10-15 are an improvement to the stroke volume equation 16. However, stroke volume equation 16 is useful in determining the person-specific volumetric constant C, which is then used to determine a more accurate stroke volume using equations 10-15. For determining constant C, alternative stroke volume SV equations and techniques can be substituted for equation 16 and thus the numerator of equation 17. Such SV equations may be other impedance-derived SV equations, such as those implemented by means of the transthoracic and transbrachial methods, as well as SV methods using Doppler velocimetry and echo-imaging of the aortic valve. Other noninvasive SV methods, including rebreathing of inert gases, noninvasive pressure pulse contour methods, or even magnetic resonance imaging may be implemented, the results of which can be used as the numerator of equation 17.

Rationale for integrating the waveforms from the aggregate radial (and ulnar) arteries derive from the observation that trivial diameter change (approximately 1.5%) occurs over a wide range of blood pressures in normotensives and hypertensives (Arterioscler Thromb 1994; 14:1223-1231), which implies that the impedance change, $dZ(t)$ is virtually a pure velocity induced change in blood resistivity with trivial luminal volumetric expansion (ΔD , Δ diameter). Evaluating the following equation,

$$dZ(t) = \dot{Q}_Z = d\rho_b(t) \frac{L^2}{V_b} = \frac{\Omega \cdot \text{cm} \cdot \text{cm}^2}{s \cdot \text{cm}^3} = \Omega \cdot s^{-1} \tag{Equation 18}$$

The differential of Equation 18 is given below:

$$\frac{dZ(t)}{dt} = \dot{Q}_Z = \frac{L^2}{V_b} \frac{d\rho_b(t)}{dt} = \frac{\text{cm}^2}{\text{cm}^3} \cdot \frac{\Omega \text{cm}}{s^2} = \frac{\Omega}{s^2} \tag{Equation 19}$$

If L (the distance between the voltage-sensing electrodes) remains constant, and if V, vessel diameter, cross-sectional area and volume are virtually constant (i.e. $dV(t) \rightarrow 0$), then $dZ(t)$ and $dZ(t)/dt$ vary uniquely with $d\rho_b(t)$ the blood resistivity change and its rate of change of $d\rho_b(t)/dt$, respectively. If $d\rho_b(t)$ and $d\rho_b(t)/dt$ are the sole variables, then $dZ(t)$ and $dZ(t)/dt$ are purely a function of the velocity-induced blood resistivity change and rate of change, respectively.

Equation 17

Others (Wallace et al. Endotracheal Cardiac Output Monitor. Anesthesiology 2000; 92:178-189) have proposed integrating the $dZ(t)$ waveform from the tracheal mucosa. The integration of $dZ(t)$ proposed to obtain SV is given by the following equation:

$$SV_{shmulewitz} = m \times \int_{BET}^{EET} DZ dt \quad \text{Equation 20}$$

where m is constant of proportionality, BET =point B, EET =point X, $DZdt=dZ(t)dt$. The Shmulewitz equation, without definition of m , however, does not lead directly to SV. It is noted that the integral results in an ohmic dimension of Z . When Z is multiplied by m , the following results:

$$SV_{shmulewitz} = m \cdot Z \quad \text{Equation 21}$$

As discussed by Wallace et al., “ m ” takes the form of the Nyboer-Kubicek or Bernstein-Sramek volume conductors, which results by rearrangement in the following:

$$SV = \text{Volume} \times \frac{Z}{Z_0} = mL \quad \text{Equation 22}$$

Other assumptions of the Shmulewitz method require comment. The assumption that dZ , (i.e. $\Delta Z(t)$, $dZ(t)$), is generated purely by volumetric (i.e. plethysmographic) changes of the aorta and aortic arch is probably an oversimplification. Many studies have shown that impedance changes of the ascending aorta and the arch also comprise a significant change in velocity-induced blood resistivity. The velocity component probably contributes up to 50% of the dZ signal (Sakamoto K, Kanai H. Electrical properties of flowing blood. IEEE Trans Biomed Eng. 1979; 26:686-689; Kosicki et al. Contributions of the impedance cardiogram waveform. Ann Biomed Eng. 1986; 14:67-80; Visser K R. Electric properties of flowing blood and impedance cardiography. 1989; 17:463-473; Visser K R et al. Investigation of the origin of the impedance cardiogram by means of exchange transfusion with stroma-free haemoglobin solution in the dog. Cardiovasc Res. 1990; 24:24-32). Therefore, depending on the compliance of the aorta, the ratio of volumetric (plethysmographic) to blood resistivity changes is not a constant and unknown. Therefore, integrating the area beneath the aortic arch $dZ(t)$ waveform may not consistently yield ohmic equivalents of true rate of change of volume (i.e. aortic flow). Other assumptions, such as modeling “ m ” after the Nyboer/Kubicek or Bernstein/Sramek methods, may not yield physiologically valid results, because they are purely empiric constructs, derived from basic laws of electricity. These inconsistencies contribute to the generally poor results in humans reported in the medical literature for endotracheal bioimpedance SV and CO (Moller-Sorensen H et al. Lack of agreement and trending ability of the endotracheal cardiac output monitor, compared to thermodilution. Acta Anaesthesiol Scand. 2012; 56:433-440; Maus T M et al. Cardiac output determination from endotracheal cardiac output monitor. J Cardiothorac Vasc Anesth. 2011; 25:770-775; Maass S W et al. Cardiac output measurement by bioimpedance and noninvasive pulse contour analysis compared with pulmonary artery thermodilution technique. J Cardiothorac Vasc Anesth. 2014; 28:534-539; Fellahi J L et al. A comparison of endotracheal bioimpedance cardiography and transpulmonary thermodilution in cardiac surgery patients. J Cardiothorac Vasc Anesth. 2012; 26:217-222; Ball T R et al. Comparison of the endotracheal cardiac output monitor to thermodilution in cardiac surgery patients. J Cardiothorac Vasc Anesth. 2010; 24:762-766).

A method of determining stroke volume by bioimpedance from a person can include positioning two or more spaced apart alternating current flow electrodes on the forearm of a person, positioning two or more spaced apart voltage sensing electrodes on the forearm of the person and between the alternating current flow electrodes, providing a constant magnitude alternating current flow through the alternating current flow electrodes, measuring a voltage between the voltage sensing electrodes, and determining a stroke volume (SV) using the measured voltage and the above described equations.

The invention and the various features and advantageous details thereof are explained more fully with reference to the non-limiting embodiments that are illustrated in the accompanying drawings and detailed in the following description. Descriptions of well-known starting materials, processing techniques, components, and equipment are omitted so as not to unnecessarily obscure the invention in detail. It should be understood, however, that the detailed description and the specific examples, while indicating preferred embodiments of the invention, are given by way of illustrations only and not by way of limitation. Various substitutions, modifications, additions and/or rearrangements within the spirit and/or scope of the underlying inventive concept will become apparent to those skilled in the art from this disclosure.

As used herein, the terms “comprises”, “comprising”, “includes”, “including”, “has”, “having” or any other variation thereof, are intended to cover a non-exclusive inclusion. For example, a process, method, article, or apparatus that comprises a list of elements is not necessarily limited to only those elements but may include other elements not expressly listed or inherent to such process, method, article, or apparatus. Further, unless expressly stated to the contrary, “or” refers to an inclusive or and not to an exclusive or. For example, a condition A or B is satisfied by any one of the following: A is true (or present) and B is false (or not present) and B is true (or present), and both A and B are true (or present).

Also, use of the “a” or “an” are employed to describe elements and components of the invention. This is done merely for convenience and to give a general sense of the invention. This description should be read to include one or at least one and the singular also includes the plural unless it is obvious that it is meant otherwise.

Unless otherwise defined, all technical and scientific terms used herein have the same meaning as commonly understood by one of ordinary skill in the art to which this invention belongs. Although methods and materials similar or equivalent to those described herein can be used in the practice or testing of the present invention, suitable methods and materials are described below. All publications, patent applications, patents, and other references mentioned herein are incorporated by reference in their entirety. In case of conflict, the present specification, including definitions, will control. In addition, the materials, methods, and examples are illustrative only and not intended to be limiting.

FIG. 1 shows placement of electrodes on a person’s lower arm (forearm). A.C. (I) **100** is injected through a segment of the lower arm, otherwise known as the forearm **102**, the AC **100** injected through a first current flow wire **104** operably connected to a first current flow electrode **108** proximal to the antecubital fossa and a second current flow wire **106** operably connected to a second current flow electrode **110** proximal to the wrist. A first voltage-sensing electrode **112** placed distal to the first current flow injector electrode **108** and a second voltage-sensing electrode **114** proximal and cephalad to the second current flow electrode **110**. The first

voltage sensing electrode **112** is operably connected to a first voltage-sensing wire **116** and the second voltage-sensing electrode **114** operably connected to a second voltage-sensing wire **118**, where both voltage-sensing wires **116,118** are operably connected to a voltmeter **120**. The voltmeter **120** is operably connected to a differential amplifier **122**, where the voltage is fed from amplifier **122** to a voltage demodulator **124**. The demodulated voltages undergo phase adjustment **126**, and are then subject to noise reduction, fed into a low pass filter **128** (30 Hz) and then further fed into a high pass filter **130** (0.1 Hz) to yield oscillating voltage ΔZ **132** and through a second low pass filter **134** (10 Hz) yielding a static impedance voltage Z_0 **136**. ΔZ **132** and Z_0 **136** are then fed into an analog to digital (A to D) converter **138**, the A to D conversion signal is fed into a signal microprocessor unit (SMU) **140** where ΔZ **136** undergoes electronic differentiation to dZ/dt , where the peak value of dZ/dt is found dZ/dt_{max} **142**, the square root of $dZ/dt_{max}/Z_0$ is calculated, systolic flow time (T_{SF}) **144** is determined, $dZ(t)/dt$ and $dZ(t)$ undergo sequential area integration **145** and a person-specific constant C **146** is calculated from a person's body weight. From equations 9 through 17, already discussed, stroke volume (SV) **148** is calculated, and the cardiac output (CO) **150** calculated as the product of heart rate **152** and SV **148**. Also shown is an accelerometer **154** operably connected within the signal microprocessor unit (SMU) **140**.

FIG. 2 is a schematic of the transradioulnar impedance ($Z(t)$), further comprising four elements. The three static elements include the impedance path through the adynamic tissues (Z_t), such as bone, muscle and connective tissue, the impedance path through the blood (Z_b), and interstitial water (Z_w). The parallel connection of these static and quasi-static (Z_w) impedances constitutes the transradioulnar base impedance, 4. Excluding the respiratory variation of Z (ΔZ_{resp}), the parallel connection between 4 and the dynamic pulsatile component of the blood impedance/resistance ($\Delta Z_b(t)$) constitutes the total impedance of the forearm ($Z(t)$) between the voltage sensing electrodes. Shown are the alternating current flow input (AC, $I(t)$) and the time variable voltage output ($U(t)$).

FIGS. 3A and 3B shows two waveforms. In the waveform in FIG. 3A, ΔZ , 1) Point B represents the onset of flow; 2) point C represents the peak systolic upslope or peak time rate of change of the impedance pulse waveform, namely, transradioulnar dZ/dt_{max} ; and 3) point X represents termination or end of flow. The temporal interval between point B and point X represents systolic flow time (T_{SF}), the time during which forward SV is measured. For FIG. 3B, biphasic sinusoidal dZ/dt , fiducial landmarks further comprise, point B, the onset of flow and first crossing of Z_0 before point C, which is dZ/dt_{max} ; point 0, where dZ/dt equals 0 and the first zero crossing of Z_0 after dZ/dt_{max} ; and point D, which is dZ/dt_{min} (i.e. $-dZ/dt_{max}$), and point X which is the second zero crossing of Z_0 after dZ/dt_{max} which signals the end of flow. Point 0 segregates $+dZ/dt$ above baseline Z_0 from $-dZ/dt$ below baseline Z_0 .

FIG. 4 shows a person's forearm **102** with two spaced apart current flow electrodes **108,110**, a first current flow electrode just distal to the antecubital fossa, proximally **108**, and a second current flow electrode placed distally and proximal the wrist **110**. Between the first and second two spaced-apart current flow electrodes **108,110** are the two spaced-apart voltage sensing electrodes **112,114**, the first voltage sensing electrode **112** below the antecubital fossa and distal to the first current flow electrode **108** and the second voltage sensing electrode **114** placed near the wrist,

proximal and cephalad to the second current flow electrode **110**. Shown is a wrist-worn device (**115**) (e.g. a band that is configured to wrap around and secure to the wrist) and within, a battery powered current flow generator **100**. The current flow generator is operably connected to two current flow electrode wires **104, 106**, the first current flow wire **104** operably connected to the first current flow electrode **108** proximal the antecubital fossa, and the second current flow electrode wire **106** operably attached to the second current flow electrode **110**. Voltage sensing electrodes **112, 114**, proximal the respective current flow electrodes **108, 110** are operably connected to the two voltage sensing wires **116, 118**, where the first voltage sensing wire **116** is operably connected to the first voltage sensing electrode **112** and the second voltage sensing wire **118** operably connected to the second voltage sensing electrode **114**. Voltage sensing wires **116,118** are fed into the voltmeter **120** operably connected to a signal-processing unit **121**, the signal-processing unit yielding a value for SV **123**.

FIG. 5 shows a person's forearm **102** with current flow generator **100** operably connected to current flow electrode wires **104,106**, which are operably connected to current flow electrodes **108,110**, respectively. Voltage sensing electrodes **112, 114** are operably connected to voltage sensing wires **116, 118**, respectively, which are operably connected to a voltmeter **120**. The voltmeter **120** is operably connected to a signal-processing unit **121** of a wrist-worn device **115**, where the signal-processing unit **121** is placed inside the wrist-worn device **115**. The wrist-worn device **115** externally shows a view screen with light emitting diode (LED) **125** or a liquid crystal device (LCD) **127**, the LED/LCD displaying a value for stroke volume **123**, heart rate **129**, and cardiac output **131**.

FIG. 6 additionally shows a cable **133** operably connected to multi-parameter view screen **125, 127** of an exercise machine **132-A**, the exercise machine being a stationary bicycle **133**, treadmill **135**, elliptical pedaling device **137**, a stair-climb machine **139**, or equivalent machine. The multi-parameter view screen **125,127** displays values for SV **123** HR **129** and CO **131**.

FIG. 7 additionally shows a cable **133** connecting the wires **104/106** to a current flow generator **100** incorporated as part of the exercise machine **132-A**, and connecting wires **116, 118** to the voltmeter **120** incorporated as part of the exercise machine **132-A**. The signal processing unit **121** also attached to the exercise machine **132-A** is connected to the view screen **125, 127** of the exercise machine for displaying a value for stroke volume **123** (SV), heart rate (HR) **129**, and cardiac output (CO) **131**.

FIG. 8 additionally shows voltmeter **120** connected to a signal processing unit **121**, which is attached to a signal transmission module **141** for wirelessly relaying values for SV **123**, HR **129**, CO **131** to the signal receiver unit **143** of the exercise machine **132-A** so that the view screen (LED/LCD) **125, 127** of the exercise machine **132-A** can display values for SV **123**, HR **129** and CO **131**.

FIG. 9 shows a person's forearm **102** where the four electrodes **108, 112, 114, 110** are situated and attached on an adhesive carrying strip **111**. The current flow wires **104, 106** and the voltage sensing wires **116, 118** are tethered upon exiting the adhesive electrode strip on single cable **119** that eventually connected to the current flow generator **100** and the voltmeter **120**.

The present invention is a method and apparatus for the determination of stroke volume (SV) and cardiac output (CO) by transradioulnar electrical bioimpedance velocimetry, wherein the signal sources are the radial and ulnar

arteries of the forearm. SV and CO, while not sensitive indices of the overall intrinsic force generation capacity or contractility of the heart muscle, are the best indicators of the overall performance of the heart considered as a muscular pump. The apparatus and method disclosed involve the application of a constant magnitude alternating current of high frequency and small amplitude across a segment of a person's lower arm (forearm) of the upper extremity to interrogate both the radial and ulnar arteries, considered in the aggregate. The present invention may also provide a method to determine a stroke volume equation, including a method for calibration of the transradioulnar person-specific constant C. Thus, in contradistinction to the generally accepted transthoracic bioimpedance method for SV/CO determination, the present invention relates to the acquisition and signal processing of the cardiogenically induced, pulsatile transradioulnar bioimpedance signal for the purpose of SV/CO determination.

Advantages of the transradioulnar method include:

1. Stroke volume (SV) and cardiac output (CO) values are not corrupted by excess extravascular, intrathoracic liquids; namely pulmonary edema fluid.
2. Baseline transradioulnar quasi-static base impedance, Z_0 , is not substantially affected by pulmonary (lung) ventilation, thereby obviating the necessity for sophisticated stabilizing adaptive filtering techniques to obtain a steady baseline for measurement of the cardiac-induced transradioulnar impedance change, $\Delta Z(t)$, and the magnitudes and fiducial landmarks on its first time-derivative transradioulnar dZ/dt .
3. The cumbersome and user-unfriendly transthoracic electrode montage, and the difficult self-application of the transbrachial electrode configuration, is replaced with a user-friendly 4 spot-electrode montage affixed to an adhesive strip, the adhesive strip affixed to the ventral (volar) aspect of the forearm.
4. With the arm at rest, or the arm stabilized by handle bars of a stationary exercise machine, including a bicycle, treadmill, stair-climb, or elliptical pedaling device, motion artifact is limited and is easily filtered by the signal processing module located on the wrist or exercise machine and/or with an integrated tri-axial accelerometer.
5. The bioimpedance signal obtained from the forearm is unaffected by the presence of electronic or metallic devices located on the surface of the chest, or within the chest cavity.
6. Without the perturbing influence of multiple pulsating blood vessels, both arterial and venous, and motion of the heart and chest wall, the signal-to-noise ratio (S/N) of the arterial pulsations of the forearm are enhanced over the various transthoracic bioimpedance methods.
7. The radial and ulnar arteries are more rigid than either the vessels of the chest cavity, including the thoracic aorta, or the brachial artery, thereby yielding a pulsatile velocimetric bioimpedance waveform without the perturbation of vessel volume changes over the cardiac cycle.
8. Fiducial landmarks, point B and point X are more easily identified from the biphasic dZ/dt curve.
9. The integration of $dZ(t)$ and $dZ(t)/dt$ provide a biophysically coherent explanation for the legitimacy of the impedance method for determination of SV and CO.

As disclosed above, the present invention relates to the measurement of stroke volume (SV) and cardiac output (CO) by means of the transradioulnar method, using the

radial and ulnar arteries, in the aggregate, as the cardiogenically induced signal source. Methodologically, the transradioulnar method is similar to the transthoracic and transbrachial techniques for determining SV. However, in the transthoracic technique, signal acquisition is effected over a segment of the thorax (U.S. Pat. No. 7,806,830 B2, FIG. 7) and the transbrachial technique over a segment of the brachium (upper arm) (U.S. Pat. Nos. 7,261,697 B2, 7,740,590 B2 7,806,830 B2, all three of these patents are incorporated herein by reference for all purposes. In contrast, the transradioulnar technique uses a segment of the lower arm, namely the forearm, for signal acquisition.

FIG. 1 schematically shows one apparatus embodiment according to the present invention, and its electrical interface with a subject's forearm (lower arm) 102. Signal acquisition from the lower arm 102 requires application of a constant magnitude alternating current (A.C.) 100 of high frequency and small amplitude to current flow wires 104 and 106 feeding into current flow electrodes 108 and 110, respectively, that are spaced-apart with the first current flow electrode 108 affixed to the skin of the upper forearm, distal to the antecubital fossa, as well as with the second current flow electrode 110 placed at the lower forearm proximal the wrist, thereby generating a current field between the current flow electrodes 108,110. In the embodiments, the electrodes can be placed on either forearm (left or right).

With the current field thus generated, the potential difference between the current injecting electrodes (AKA alternating current flow electrodes) 108,110 is measured by a voltmeter 120 connected to voltage-sensing wires 116, 118, which are connected, respectively, to voltage sensing electrodes 112 proximal and distal to 108 and 114 placed proximal and cephalad to 110 within the current field. The voltage then passes through differential amplifier 122, then through voltage demodulator 124 whereupon the demodulated voltage undergoes phase adjustment 126. After phase adjustment, and to increase the signal to noise ratio (S/N), the signal is denoised by passage through a first low pass filter 128 (30 Hz). The denoised signal then passes through a high pass filter 130 (0.1 Hz) yielding oscillating signal ΔZ 132, followed by passage through a second low pass filter (10 Hz) 134, yielding quasi-static base impedance signal Z_0 136. Both 132, 136 are then fed into an analog to digital converter (A to D) 138, whereupon the A to D conversion is fed into the signal (micro) processing unit (SMU, SPU) 140 wherein the $\Delta Z(t)$ 132 signal is electronically differentiated into its first time-derivative, transradioulnar $d(\Delta Z(t))/dt$, hereafter simply designated as dZ/dt ($\Omega \cdot s^{-2}$), where its peak systolic magnitude is thus designated as dZ/dt_{max} 142. The SPU can also effect integration of area beneath the initial concave downward impedance envelope ($+dZ/dt$) as well as the area within the impedance concave upward envelope bounded by point 0, $-dZ/dt$ and point X 145. Systolic flow time (T_{SFT} , s) 144 is calculated and a volume conductor, personal constant C 146 is calculated based on person's body weight (kg). For the purposes of the invention disclosed herein, dZ/dt_{max} ($\Omega \cdot s^{-2}$) is equivalent to the nadir, or peak negative value of the rate of change of the impedance pulse variation, $-dZ/dt_{max}$ (i.e. dZ/dt_{min}) where the absolute value of $-dZ/dt_{max} = +dZ/dt_{max} = -dZ/dt_{min}$.

In the embodiments of FIGS. 1 and 4 through 8, SV 148,123 is evaluated using equation 14 or equation 15. For systolic flow time (SFT), point B to point X for equation 15, SFT is preferably measured from the point B to point X of the acceleration waveform, dZ/dt . For equations 9 through 15 (vide supra), the integrals represent the areas associated with curves dZ/dt and $dZ(t)$. For the biphasic dZ/dt curves,

they are denoted by the area above the baseline Z_0 as $+dZ/dt$ and the area below the baseline Z_0 as the absolute value of $-dZ/dt$. Regardless of sign, they are added positively in the aggregate. Equations 9-11 result in $dZ(t)$, otherwise known as ΔZ . Integration of the aggregate of $+dZ(t)$ and $-dZ(t)$, that is the integration of $+dZ(t)dt$ and the absolute value of $-dZ(t)dt$, results in SV.

C is a person-specific volumetric constant based on allometric equivalents of body mass (kg). Person-specific constant C can be calculated as follows. First, per U.S. Pat. No. 9,451,888 B1, SV can be calculated thusly:

$$SV = [a^p W^b] \cdot \left[\frac{k_1 k_2}{(dZ(t)/dt_{max} \cdot Z_0^{-1})^{0.5}} \right] \cdot \left[\frac{dZ(t)/dt_{max}}{Z_0} \right] \cdot T_{SF} \quad \text{Equation 23}$$

where $dZ(t)/dt_{max}$ is the peak rate of change of the cardiogenically-induced transradioulnar impedance pulse variation (Ω/s^2). The aforementioned equation is used solely to calculate the person-specific constant C, the definition of terms of which are disclosed in U.S. Pat. No. 9,451,888 B1. Therefore, the person specific weight-based constant C is calibrated thusly:

$$C = \frac{[a^p W^b] \cdot \left[\frac{k_1 k_2}{(dZ/dt_{max} \cdot Z_0^{-1})^{0.5}} \right] \cdot \left[\frac{dZ/dt_{max}}{Z_0} \right] \cdot T_{SF}}{\int_B^X \frac{dZ(t)dt}{Z_0}} \quad \text{Equation 24}$$

Using equations 9 through 15 to determine SV **148**, cardiac output (CO) **150** is determined by the product of **148** and heart rate (HR) **152**. An accelerometer **154** within the SMU **140** is implemented to detect and stabilize motion artifacts in Z_0 **136** and ΔZ and dZ/dt **132**.

Many different methods of applying the electrodes or electrode arrays to the forearm are envisioned, such as spot electrodes, arm bands, both circumferential and non-circumferential, adhesive strips, or other attachment means known to the art. In the preferred embodiment, however, four (4) spot-electrodes are affixed to the forearm by means of attachment to an adhesive carrier strip (see FIG. 9), or, alternatively, independently spaced-apart with separated electrode patches. The voltages measured by the voltmeter **120** contains not only a signal caused by the AC applied, but may also contain a signal component from which an electrocardiogram (ECG) can be derived (Lynn W D et al. Arm and wrist surface potential mapping for wearable ECG rhythm recording devices: a pilot study. *J Phys: Conf Ser* 2013; 450, and Goncalves S et al. Non-contact wearable single forearm cardiac biopotential acquisition device. *J Phys: Conf Ser* 2013; 459). The application of filters separates the AC related and ECG related signal components. The apparatus may also contain a data input device. The input device may be any suitable device that provides information to the apparatus, such as a person's age, height, weight, and gender. The input device may also receive information from external sources, such as the ECG or even information from a pulse oximeter located on the forearm (reflectance oximeter) or on a finger (transmittance oximeter). The signal microprocessor **140** is in communication with the data input device, the alternating current source **100**, current flow electrodes **108,110**, the voltage-sensing electrodes **112,114** and voltmeter **120**. The processor (SMU, SPU) **140** is capable of receiving the information and

calculating the stroke volume **148** and cardiac output **150** of a person. The stroke volume and cardiac output of the person may be displayed on a view screen on a wrist-worn device or sent by cable or wirelessly via the data output device of the apparatus to a peripheral view screen FIGS. 5, 6, 7, 8.

To better understand the biological electronic circuitry, a second embodiment of the invention FIG. 2 shows a schematic circuit diagram with an AC input ($I(t)$) to a body part, namely the forearm. An AC field is applied to the total impedance of the forearm ($Z(t)$) between the voltage sensing electrodes. The forearm impedance further comprises the static tissue impedances (muscle, fat, nerves, vascular tissue, bone) Z_t , an impedance compartment comprising interstitial tissue water (Z_w) and an impedance compartment comprising the blood (Z_b) resistance. They are all added electrically in parallel, comprising the quasi-static base impedance Z_0 . In parallel with Z_0 is the dynamic, time-dependent, cardiogenically induced component of the blood resistance $\Delta Z_b(t)$ (i.e. ΔZ). Excluding the respiratory component of Z, the parallel connection of Z_0 and $\Delta Z_b(t)$ constitutes the total forearm impedance $Z(t)$ between the voltage-sensing electrodes. The dot product of $I(t)$ and $Z(t)$ yields a static voltage U_0 and an oscillating voltage $\Delta U_b(t)$. As pertains to parallel electronic circuitry for AC, the impedances are added as their reciprocals:

$$\frac{I(t) \cdot [(\|Z_t\| \|Z_w\| \|Z_b\|) \Delta Z_b(t)]}{U_0 \| \Delta U_b(t)} = U_0 \| \Delta U_b(t) = I(t) \cdot [Z_0 \| \Delta Z(t)] = \quad \text{Equation 25}$$

In a third embodiment, FIG. 3 shows two (2) waveforms; the upper waveform in FIG. 3A, labeled ΔZ , is the time-dependent impedance pulse variation over a segment of forearm undergoing electrical interrogation, wherein point B represents the onset of flow over the segment of forearm interrogated, point C represents the maximum systolic forward upslope of the cardiogenically-induced impedance change, and point X represents the end of flow of the interrogated segment of forearm. The temporal interval from point B to point X is the systolic flow time (T_{SF}). The lower waveform in FIG. 3B, labeled dZ/dt , is the first time-derivative (time rate of change) of ΔZ , wherein point B is the first crossing of Z_0 before dZ/dt_{max} , which represents the onset of flow in the segment of forearm under electrical interrogation, point C represents the peak rate of change of the upslope of ΔZ , which is dZ/dt_{max} , point 0 represents the first Z_0 crossing after dZ/dt_{max} , point D represents the nadir of dZ/dt , which is dZ/dt_{min} ($-dZ/dt_{max}$), and point X which represents the second Z_0 crossing after dZ/dt_{max} , and end of flow in the segment of forearm undergoing electrical interrogation. The temporal interval between point B and point X of the dZ/dt waveform represents the systolic flow time T_{SF} over the forearm segment electrically interrogated. Alternatively, equivalent fiducial landmarks on second time derivative of the impedance change ΔZ , namely d^2Z/dt^2 , can be implemented to determine T_{SF} . It is also envisioned that T_{SF} can be determined by means of the SpO_2 curve, or its first time-derivative $d(SpO_2)/dt$ as disclosed in U.S. Pat. Nos. 7,261,697 B2, 7,740,590 B2, and 7,806,830 B2. It is envisioned that the SpO_2 signal can be obtained from the earlobe, forehead, or other signal acquisition sites on the body, but in the preferred embodiment the signal may be determined from a fingertip, base of finger or on the forearm. Systolic flow time T_{SF} , equivalent to left ventricular ejection time LVET, can be approximated in persons with healthy hearts as:

$$\begin{aligned} \text{Male: } T_{SF} &= -0.0017 \cdot HR + 0.413, \text{ and} \\ \text{Female: } T_{SF} &= -0.0016 \cdot HR + 0.418. \end{aligned}$$

(Weissler et al. Systolic time intervals in heart failure in man. Circulation 1968; 37:149.)

In a fourth embodiment of the invention, FIG. 4 shows the forearm 102 of the right upper extremity of a person undergoing electrical interrogation. The forearm of the left upper extremity (left upper arm) can be used equivalently. The current flow generator 100 delivers a constant magnitude high frequency (70-100 kHz), small amplitude (2-4 mA) oscillating current (AC) by means of 2 current flow wires 104,106 leading to 2 spaced-apart current flow electrodes 108,110 whereupon a current field is applied to the segment of forearm between the current flow electrodes 108,110. Spaced-apart voltage sensing electrodes 112,114 located proximal the current flow electrodes 108,110 and within the current field direct the voltage via voltage sensing wires 116,118 to a voltmeter 120 located within the signal processing unit 121 operably attached to a wrist-worn device 115, the signal-processing unit capable of calculating a stroke volume (SV) 123, displayed on the view screen of the wrist worn device.

In a fifth embodiment, FIG. 5 shows a person's forearm 102 with current flow electrodes 108,110 operably connected to current flow wires 104,106, which are operably attached to a current flow generator 100 generating a current field between voltage sensing electrodes 112,114 that are operably attached to voltage sensing wires 116,118 feeding into a voltmeter 120. The voltmeter is operably attached to a signal-processing unit 121 of a wrist-worn device 115. The signal-processing unit 121 is placed inside a wrist-worn device 121, the wrist-worn device 121 externally showing a view screen with light-emitting diode (LED) 125 or a liquid crystal display (LCD) 127, the LED/LCD displaying a value for stroke volume (SV) 123, heart rate (HR) 129, and cardiac output (CO) 131.

In a sixth embodiment, FIG. 6 shows a cable 133 operably connected to a multi-parameter view screen 125,127 of an exercise machine 132-A, the exercise machine being a stationary bicycle 133-A, treadmill 135, elliptical pedaling device 137, a stair-climb machine 139, or other similar exercise machine. The multi-parameter view screen 125,127 displays values for SV 123, HR 129, and CO 131.

In a seventh embodiment, FIG. 7 shows a cable 133 connecting the wires 104/106 to a current flow generator 100, and voltage sensing wires 116,118 to voltmeter 120, where the voltmeter 120 and current flow generator 100 are operably connected to the signal processing unit 121 attached to an exercise machine 132-A, where view screen 125,127 of the exercise machine 132-A displays a value for SV 123, HR 129, and CO 131.

In an eighth embodiment, FIG. 8 shows voltmeter 120 connected or housed in the signal receiving unit of the signal processing unit 121. The signal processing unit 121 yielding values for SV 123 HR 129 and CO 131 which are telemetered by a signal transmission unit 141 wirelessly to a signal receiving unit 143 of exercise machine 132-A. The view screen 125,127 attached to the signal-receiving unit 143 displays values for SV 123 HR 129 and CO 131.

In the ninth embodiment, FIG. 9 shows a person's forearm 102 with an adhesive electrode tape 111 applied to the ventral surface of the forearm 102, the adhesive tape attached to embedded current flow electrodes 108,110 current flow wires 104,106 voltage sensing electrodes 112,114 and voltage sensing wires 116,118, the voltage sensing and current flow wires tethered to a cable 119 operably connected to the signal processing unit (SPU) housing the current flow generator 100 and voltmeter 120.

In a tenth and final embodiment, heart rate HR can be determined by the following means:

The SPU can receive, detect and process ECG signals and,

1. Measure the R-R time intervals of an ECG over a given period of time Δt ,
2. Divide 60 seconds by the average of the R-R time intervals over Δt .
3. Examples:
 - a. If the average R-R time interval is 0.5 seconds over one minute Δt (60 s), then $\Delta t/R-R=60/0.5=120$ beats per minute (BPM).
 - b. If the average R-R time interval is 0.5 seconds over Δt 15 seconds, then

$$HR=60/\Delta t \times \Delta t/0.5=60/15 \times 15/0.5=120 \text{ BPM.}$$

- c. If the average R-R time interval is 2 seconds over one minute Δt (60 s), then the heart rate= $60/2=30$ BPM.
- d. If the average R-R time interval is 2 seconds over Δt 15 seconds, then

$$HR=60/\Delta t \times \Delta t/2=60/15 \times 15/2=30 \text{ BPM.}$$

The SPU can receive, detect and process ECG signals and,

1. Measure the number of ECG R wave spikes over a stipulated period of time Δt .
2. Multiply number of R spikes $\times 60/\Delta t$.
3. Examples:
 - a. If 20 R wave spikes occur in 15 seconds, then $20 \times 60/15=20 \times 4=80$ BPM.
 - b. If 30 R wave spikes occur in 15 seconds, then $30 \times 60/15=30 \times 4=120$ BPM.

The SPU can receive, detect and process SpO_2 signals and:

1. Determine the first time-derivative of SpO_2 , $d(SpO_2)/dt$,
2. The first and largest spike of the derivatized waveform $d(SpO_2)/dt_{max}$ can be treated as per the methods outlined and disclosed in U.S. Pat. Nos. 7,261,697 B2, 7,740,590 B2 and 7,806,830 B2 and treated as in methods using ECG or $d(SpO_2)/dt$.
3. The second time-derivative, $d^2(SpO_2)/dt^2$ can be used as per methods for $d(SpO_2)/dt$ or ECG to determine HR ($d(SpO_2)/dt_{max}$ to $d(SpO_2)/dt_{max}$ time interval).

The SPU can receive, detect, and process the first or second time derivatives of ΔZ and:

1. The maximum of dZ/dt or d^2Z/dt^2 , which are dZ/dt_{max} or d^2Z/dt^2_{max} respectively, can be treated as per the method using ECG or $d(SpO_2)/dt$ to determine HR.
2. Specifically, the time interval between the maximum systolic peaks (dZ/dt_{max} to dZ/dt_{max}) can be treated as per the methods delineated in treatment of ECG or SpO_2 signals.

It is to be understood that the present invention is not limited to the embodiment(s) described above and illustrated herein, but encompasses any and all variations falling within the scope of the appended claims. For example, references to the present invention herein are not intended to limit the scope of any claim or claim term, but instead merely make reference to one or more features that may be covered by one or more of the claims. Materials, processes and numerical examples described above are exemplary only, and should not be deemed to limit the claims. Further, as is apparent

from the claims and specification, not all method steps need be performed in the exact order illustrated or claimed.

Hardware, software and/or firmware can be used to implement the logic steps and/or processes of the invention. It should further be appreciated that such logic steps or process can be implemented as computer-executable instructions stored on a non-transitory computer readable medium, such as a CD or DVD (including re-writable CDs and DVDs), flash or other non-volatile memory, ROM, EEPROM, disc drive, solid state drive, etc.

What is claimed is:

1. An apparatus for determining stroke volume by bioimpedance from a person, comprising:

two or more spaced apart alternating current flow electrodes positionable on a person;

two or more spaced apart voltage sensing electrodes positionable on the person and between the alternating current flow electrodes;

a constant magnitude alternating current source electrically connectable to the alternating current flow electrodes;

a voltmeter electrically connectable to the voltage sensing electrodes and configured to generate a voltage signal Z from a voltage sensed by the voltage sensing electrodes;

a processing unit electrically connectable with the voltmeter and configured to determine a stroke volume (SV) using the voltage signal Z and at least one of the following six equations:

$$\dot{Q}_Z = C \cdot \frac{\left[\int_{t_B}^{t_0} \frac{dZ(t)}{dt} dt + \int_{t_0}^{t_X} \left| -\frac{dZ(t)}{dt} \right| dt \right]}{Z_0} = C \cdot \frac{dZ(t)_{total}}{Z_0} \tag{1}$$

$$\dot{Q}_Z = C \cdot \frac{+dZ(t) + |-dZ(t)|}{Z_0} = C \cdot \frac{dZ(t)_{total}}{Z_0} \tag{2}$$

$$SV_Z = C \cdot \frac{\left[\int_{t_B}^{t_0} +dZ(t) dt + \int_{t_0}^{t_X} |-dZ(t) dt \right]}{Z_0} = C \cdot \frac{[+Z + |-Z|]}{Z_0} \tag{3}$$

$$SV_Z = C \cdot \frac{[+Z + |-Z|]}{Z_0} = C \cdot \frac{Z_{total}}{Z_0} \tag{4}$$

$$SV_Z = Q = C \cdot \frac{\int_{t_B}^{t_X} dZ(t) dt_{total}}{Z_0} = C \cdot \frac{Z_{total}}{Z_0} \tag{5}$$

$$SV = C \cdot \frac{\int_{t_B}^{t_X} dZ(t) dt}{Z_0} = C \cdot \frac{Z}{Z_0} \tag{6}$$

wherein:

\dot{Q}_Z =impedance-derived blood flow velocity (mL/s)

\int =definite integral over time intervals from t_B to t_0 and t_0 to t_X that collectively are a systolic flow time, where t_B is a beginning point of cardiogenically-induced transradioulnar impedance pulse, t_0 is a maximum point of cardiogenically-induced transradioulnar impedance pulse, and t_X is an ending point of cardiogenically-induced transradioulnar impedance pulse

$\frac{dZ(t)}{dt}$ = cardiogenically-induced rate of change of the transradioulnar impedance pulse variation

-continued

$\frac{dZ(t)}{dt_{max}}$ = peak rate of change of the cardiogenically-induced transradioulnar impedance pulse variation

$dZ(t)$ =cardiogenically-induced transradioulnar impedance pulse variation

C=constant person-specific mass-based allometric equivalent of volume

Q_Z =transradioulnar impedance-derived stroke volume

Z_0 =quasi-static transradioulnar base impedance.

2. The apparatus for determining stroke volume of claim 1, further comprising:

a data input device in communication with the processing unit for receiving the person's weight W, wherein the processing unit is configured to determine the constant person-specific mass-based allometric equivalent of volume C using the following equation:

$$C = \left[\frac{[a^b W^b] \cdot \left[\frac{k_1 k_2}{(dZ/dt_{max} \cdot Z_0^{-1})^{0.5}} \right] \cdot \left[\frac{dZ/dt_{max}}{Z_0} \right] \cdot T_{SF}}{\int_{t_B}^{t_X} \frac{dZ(t) dt}{Z_0}} \right]$$

wherein a is at least 5 and no greater than 10, n is at least 2 and no greater than 4, W is the person's weight, b is at least 1 and no greater than 2, $k_1 \cdot k_2$ collectively are a dimensionless constant at least 0.04 and no greater than 0.3, dZ/dt_{max} is a peak time rate of change of a transradioulnar impedance pulse variation, Z_0 is a transradioulnar quasi-static base impedance, T_{SF} is a systolic flow time, and Vc is cM^d where c is at least 30 and no greater than 50, M is the person's weight and d is at least 1 and no greater than 2.

3. The apparatus for determining stroke volume of claim 2, wherein the constant $k_1 \cdot k_2$ comprises:

an impedance constant k_1 at least 0.08 and no greater than 0.2, and

a calibrating temporal constant k_2 at least 0.5 and no greater than 1.5.

4. The apparatus for determining stroke volume of claim 1, wherein the processor is configured to:

determine heart rate from the voltage signal; and determine cardiac output (CO) by using the following formula: $CO=(\text{heart rate}) \times (SV)$.

5. The apparatus for determining stroke volume of claim 4, further comprising:

a band configured to wrap around and secure to a person's wrist, wherein the processing unit is mounted to the band.

6. The apparatus for determining stroke volume of claim 5, further comprising:

a display mounted to the band, wherein the display is electrically connected to the processing unit and configured to display at least one of the determined stroke volume and the determined cardiac output.

7. The apparatus for determining stroke volume of claim 4, further comprising:

an exercise machine being one of a stationary bicycle, a treadmill, an elliptical pedaling device and a stair-climbing machine, wherein the exercise machine includes a display operatively connectable to the processing unit and configured to display at least one of the determined stroke volume and the determined cardiac output.

8. The apparatus for determining stroke volume of claim 7, wherein the operative connection between the display and the processing unit comprises a cable.

9. The apparatus for determining stroke volume of claim 7, wherein the operative connection between the display and the processing unit comprises a wireless connection.

10. The apparatus for determining stroke volume of claim 7, wherein the alternating current source, a voltmeter and the processing unit are mounted to the exercise machine.

11. The apparatus for determining stroke volume of claim 1, further comprising:

an exercise machine being one of a stationary bicycle, a treadmill, an elliptical pedaling device and a stair-climbing machine, wherein the exercise machine includes a display operatively connectable to the processing unit by a wireless connection and configured to display at least one of the determined stroke volume and the determined cardiac output.

12. The apparatus for determining stroke volume of claim 1, further comprising:

an adhesive strip on which the two or more spaced apart alternating current flow electrodes and the two or more spaced apart voltage sensing electrodes are affixed.

13. A method of determining stroke volume by bioimpedance from a person, comprising:

positioning two or more spaced apart alternating current flow electrodes on the forearm of a person;

positioning two or more spaced apart voltage sensing electrodes on the forearm of the person and between the alternating current flow electrodes;

providing a constant magnitude alternating current flow through the alternating current flow electrodes;

measuring a voltage Z between the voltage sensing electrodes;

determining a stroke volume (SV) using the measured voltage Z and at least one of the following six equations:

$$\dot{Q}_Z = C \cdot \frac{\left[\int_{t_B}^{t_0} \frac{dZ(t)}{dt} dt + \int_{t_0}^{t_X} \left| -\frac{dZ(t)}{dt} dt \right| \right]}{Z_0} = C \cdot \frac{dZ(t)_{total}}{Z_0} \tag{1}$$

$$\dot{Q}_Z = C \cdot \frac{+dZ(t) + |-dZ(t)|}{Z_0} = C \cdot \frac{dZ(t)_{total}}{Z_0} \tag{2}$$

$$SV_Z = C \cdot \frac{\left[\int_{t_B}^{t_0} +dZ(t)dt + \int_{t_0}^{t_X} |-dZ(t)dt \right]}{Z_0} = C \cdot \frac{[+Z + |-Z|]}{Z_0} \tag{3}$$

$$SV_Z = C \cdot \frac{[+Z + |-Z|]}{Z_0} = C \cdot \frac{Z_{total}}{Z_0} \tag{4}$$

$$SV_Z = Q = C \cdot \frac{\int_{t_B}^{t_X} dZ(t)dt_{total}}{Z_0} = C \cdot \frac{Z_{total}}{Z_0} \tag{5}$$

$$SV = C \cdot \frac{\int_{t_B}^{t_X} dZ(t)dt}{Z_0} = C \cdot \frac{Z}{Z_0} \tag{6}$$

wherein:

\dot{Q}_Z =impedance-derived blood flow velocity (mL/s)

\int =definite integral over time intervals from t_B to t_0 and t_0 to t_X that collectively are a systolic flow time, where t_B is a beginning point of cardiogenically-induced transradioulnar impedance pulse, t_0 is a maximum point of cardiogenically-induced transradioulnar impedance

pulse, and t_X is an ending point of cardiogenically-induced transradioulnar impedance pulse

$\frac{dZ(t)}{dt}$ = cardiogenically-induced rate of change of the transradioulnar impedance pulse variation

$\frac{dZ(t)}{dt_{max}}$ = peak rate of change of the cardiogenically-induced transradioulnar impedance pulse variation

$dZ(t)$ =cardiogenically-induced transradioulnar impedance pulse variation

C=constant person-specific mass-based allometric equivalent of volume

Q_Z =transradioulnar impedance-derived stroke volume

Z_0 =quasi-static transradioulnar base impedance.

14. The method of claim 13, further comprising: determining the constant person-specific mass-based allometric equivalent of volume C using the following equation:

$$C = \frac{\left[a^p W^b \right] \cdot \left[\frac{k_1 k_2}{(dZ/dt_{max} \cdot Z_0^{-1})^{0.5}} \right] \cdot \left[\frac{dZ/dt_{max}}{Z_0} \right] \cdot T_{SF}}{\frac{\int_{t_B}^{t_X} dZ(t)dt}{Z_0}}$$

wherein a is at least 5 and no greater than 10, n is at least 2 and no greater than 4, W is a person's weight, b is at least 1 and no greater than 2, $k_1 \cdot k_2$ collectively are a dimensionless constant at least 0.04 and no greater than 0.3, dZ/dt_{max} is a peak time rate of change of a transradioulnar impedance pulse variation, Z_0 is a transradioulnar quasi-static base impedance, T_{SF} is a systolic flow time, and Vc is cm^d where c is at least 30 and no greater than 50, M is the person's weight and d is at least 1 and no greater than 2.

15. The method of claim 14, wherein the constant $k_1 \cdot k_2$ comprises:

an impedance constant k_1 at least 0.08 and no greater than 0.2, and

a calibrating temporal constant k_2 at least 0.5 and no greater than 1.5.

16. The method of claim 13, wherein the positioning of the two or more spaced apart alternating current flow electrodes on the forearm of the person comprises:

positioning a first of the two or more spaced apart alternating current flow electrodes proximal to the antecubital fossa of the person's forearm; and

positioning a second of the two or more spaced apart alternating current flow electrodes proximal to the wrist of the person.

17. The method of claim 13, further comprising: determining heart rate from the measured voltage; and determining cardiac output (CO) by using the following formula:

$$CO = (\text{heart rate}) \times (SV).$$

18. The method of claim 17, further comprising: displaying at least one of the determined stroke volume (SV) and the determined cardiac output (CO) on a visual display.

19. The method of claim 17, further comprising: mounting the visual display to the person's wrist.

20. The method of claim 17, wherein the visual display is included as part of an exercise machine being one of a stationary bicycle, a treadmill, an elliptical pedaling device and a stair-climbing machine.

21. The method of claim 13, wherein the two or more spaced-apart alternating current flow electrodes and the two or more spaced-apart voltage sensing electrodes are affixed to an adhesive strip.

* * * * *

专利名称(译)	体技术通过前臂动脉测定左心室搏动量和心输出量的方法和设备		
公开(公告)号	US10524668	公开(公告)日	2020-01-07
申请号	US15/889089	申请日	2018-02-05
[标]申请(专利权)人(译)	CORDEUS		
申请(专利权)人(译)	CORDEUS INC.		
[标]发明人	BERNSTEIN DONALD P		
发明人	BERNSTEIN, DONALD P.		
IPC分类号	A61B5/00 A63B22/06 A63B22/02 A61B5/02 A61B5/0245 A63B24/00 A63B71/06 A63B22/04		
CPC分类号	A63B71/0619 A61B5/681 A63B22/02 A61B5/02028 A63B22/04 A63B22/0605 A61B5/7239 A63B24/0062 A61B5/742 A63B22/0664 A61B5/0245 A63B2220/836 A63B2024/0065 A63B2230/04 A63B2071/0663 A63B2225/50 A61B5/029 A61B5/0295 A61B5/0535 A61B5/6824 A63B2230/06 A63B2230/207		
其他公开文献	US20190239756A1		
外部链接	Espacenet		

摘要(译)

一种用于通过生物阻抗从人中确定搏动量的装置，该人具有两个或更多个间隔开的可放置在人身上的交流电流动电极以及两个或更多个间隔开的可放置在该人身上并在交流电流动电极之间的电压传感电极。恒定大小的交流电源可电连接至交流电流动电极。电压表可电连接到电压感测电极，并且被配置为从由电压感测电极感测的电压生成电压信号Z。处理单元可与电压表电连接，并且配置为使用电压信号Z和六个方程式中的至少一个来确定行程量(SV)。

