



US010349890B2

(12) **United States Patent**
Misener et al.

(10) **Patent No.:** **US 10,349,890 B2**
(45) **Date of Patent:** **Jul. 16, 2019**

(54) **CONNECTOR INTERFACE FOR ECG-BASED CATHETER POSITIONING SYSTEM**

(71) Applicant: **C. R. Bard, Inc.**, Murray Hill, NJ (US)

(72) Inventors: **Anthony K. Misener**, Bountiful, UT (US); **Zachary S. Davis**, Sandy, UT (US); **Jason R. Stats**, Layton, UT (US)

(73) Assignee: **C. R. Bard, Inc.**, Murray Hill, NJ (US)

(*) Notice: Subject to any disclaimer, the term of this patent is extended or adjusted under 35 U.S.C. 154(b) by 98 days.

(21) Appl. No.: **15/192,561**

(22) Filed: **Jun. 24, 2016**

(65) **Prior Publication Data**

US 2016/0374589 A1 Dec. 29, 2016

Related U.S. Application Data

(60) Provisional application No. 62/185,477, filed on Jun. 26, 2015.

(51) **Int. Cl.**
A61B 5/04 (2006.01)
A61B 5/00 (2006.01)
(Continued)

(52) **U.S. Cl.**
CPC **A61B 5/6852** (2013.01); **A61B 5/042** (2013.01); **A61B 5/0404** (2013.01); **A61B 5/062** (2013.01);
(Continued)

(58) **Field of Classification Search**
CPC A61M 25/01; A61B 5/6852; A61B 5/0404; A61B 5/042; A61B 5/062
See application file for complete search history.

(56) **References Cited**

U.S. PATENT DOCUMENTS

3,133,244 A 5/1964 Wojtulewicz
3,297,020 A 1/1967 Mathiesen
(Continued)

FOREIGN PATENT DOCUMENTS

AU 642647 11/1990
AU 1860597 B2 6/1999
(Continued)

OTHER PUBLICATIONS

U.S. Appl. No. 14/309,511, filed Jun. 19, 2014 Non-Final Office Action, dated Sep. 24, 2015.

(Continued)

Primary Examiner — Christopher Koharski

Assistant Examiner — Natasha Patel

(74) *Attorney, Agent, or Firm* — Rutan & Tucker, LLP

(57) **ABSTRACT**

A connector interface configured to enable component interconnection with a location sensor of a catheter placement system is disclosed. The catheter placement system is configured to assist a clinician in positioning a catheter in a desired location within a body of a patient. In one embodiment, the location sensor assembly comprises a location sensor body for temporary placement on a portion of the patient body, and a connector interface. The connector interface is configured to removably attach to the location sensor and provide a plurality of electrically conductive pathways between the location sensor and additional components of the catheter placement system to enable the additional components to operably connect with the location sensor. The connector interface further includes a first connector configured to operably connect with a second connector of one of the additional components of the catheter placement system through a drape interposed between the first and second connectors.

26 Claims, 15 Drawing Sheets

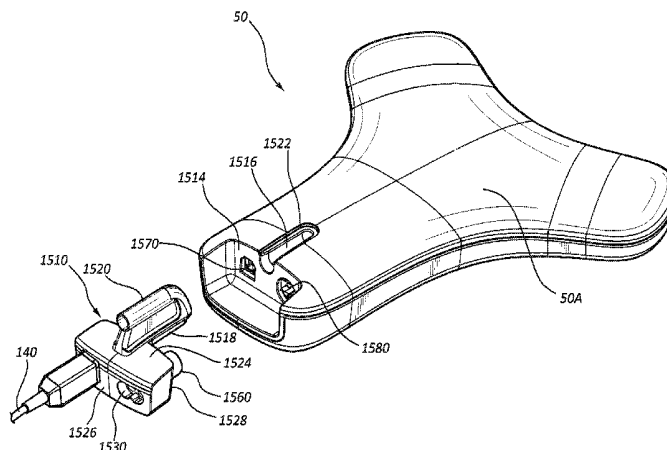

(51)	Int. Cl.		4,710,708 A	12/1987	Rorden et al.
	<i>A61M 25/01</i>	(2006.01)	4,733,669 A	3/1988	Segal
	<i>A61B 5/042</i>	(2006.01)	4,737,794 A	4/1988	Jones
	<i>A61B 5/0404</i>	(2006.01)	4,741,356 A	5/1988	Letzo et al.
	<i>A61B 5/06</i>	(2006.01)	4,742,356 A	5/1988	Kuipers
			4,753,247 A	6/1988	Kirsner et al.
(52)	U.S. Cl.		4,770,185 A	9/1988	Silverstein et al.
	CPC	<i>A61M 25/01</i> (2013.01); <i>A61B 2562/227</i>	4,771,788 A	9/1988	Millar
		(2013.01); <i>A61M 2230/04</i> (2013.01)	4,781,685 A	11/1988	Lehmann et al.
			4,784,646 A	11/1988	Feingold
			4,787,070 A	11/1988	Suzuki et al.
			4,787,396 A	11/1988	Pidorenko
(56)	References Cited		4,790,809 A	12/1988	Kuntz
	U.S. PATENT DOCUMENTS		4,793,361 A	12/1988	DuFault
			4,794,930 A	1/1989	Machida et al.
			4,796,632 A	1/1989	Boyd et al.
			4,798,588 A	1/1989	Aillon
			4,798,598 A	1/1989	Bonello et al.
			4,809,681 A	3/1989	Kantrowitz et al.
			4,809,713 A	3/1989	Grayzel
			4,813,729 A	3/1989	Speckhart
			4,821,731 A	4/1989	Martinelli et al.
			4,836,214 A	6/1989	Sramek
			4,840,182 A	6/1989	Carlson
			4,840,622 A	6/1989	Hardy
			4,841,977 A	6/1989	Griffith et al.
			4,849,692 A	7/1989	Blood
			4,850,358 A	7/1989	Millar
			4,852,580 A	8/1989	Wood
			4,856,317 A	8/1989	Pidorenko et al.
			4,856,529 A	8/1989	Segal
			4,860,757 A	8/1989	Lynch et al.
			4,867,169 A	9/1989	Machida et al.
			4,869,263 A	9/1989	Segal et al.
			4,869,718 A	9/1989	Brader
			4,873,987 A	10/1989	Djordjevic et al.
			4,887,606 A	12/1989	Yock et al.
			4,887,615 A	12/1989	Taylor
			4,889,128 A	12/1989	Millar
			4,899,756 A	2/1990	Sonek
			4,901,725 A	2/1990	Nappholz et al.
			4,905,698 A	3/1990	Strohl, Jr. et al.
			4,911,173 A	3/1990	Terwilliger
			4,911,174 A	3/1990	Pederson et al.
			4,917,669 A	4/1990	Bonaldo
			4,924,870 A	5/1990	Wlodarczyk et al.
			4,943,770 A	7/1990	Ashley-Rollman et al.
			4,945,305 A	7/1990	Blood
			4,947,852 A	8/1990	Nassi et al.
			4,957,110 A	9/1990	Vogel et al.
			4,957,111 A	9/1990	Millar
			4,961,433 A	10/1990	Christian
			4,966,148 A	10/1990	Millar
			4,967,753 A	11/1990	Haase et al.
			4,977,886 A	12/1990	Takehana et al.
			4,989,608 A	2/1991	Ratner
			4,989,610 A	2/1991	Patton et al.
			4,995,396 A	2/1991	Inaba et al.
			4,998,916 A	3/1991	Hammerslag et al.
			5,004,456 A	4/1991	Botterbusch et al.
			5,005,592 A	4/1991	Cartmell
			5,016,173 A	5/1991	Kenet et al.
			5,025,799 A	6/1991	Wilson
			5,029,585 A	7/1991	Lieber et al.
			5,040,548 A	8/1991	Yock
			5,042,486 A	8/1991	Pfeiler et al.
			5,045,071 A	9/1991	McCormick et al.
			5,046,497 A	9/1991	Millar
			5,050,607 A	9/1991	Bradley et al.
			5,057,095 A	10/1991	Fabian
			5,058,583 A	10/1991	Geddes et al.
			5,058,595 A	10/1991	Kern
			5,067,489 A	11/1991	Lind
			5,076,278 A	12/1991	Vilkomerson et al.
			5,078,140 A	1/1992	Kwoh
			5,078,148 A	1/1992	Nassi et al.
			5,078,149 A	1/1992	Katsumata et al.
			5,078,678 A	1/1992	Katims
			5,078,714 A	1/1992	Katims

(56)

References Cited

U.S. PATENT DOCUMENTS

5,084,022 A	1/1992	Claude	5,365,935 A	11/1994	Righter et al.
5,092,341 A	3/1992	Kelen	5,366,443 A	11/1994	Eggers et al.
5,099,845 A	3/1992	Besz et al.	5,368,048 A	11/1994	Stoy et al.
5,099,850 A	3/1992	Matsui et al.	5,375,596 A	12/1994	Twiss et al.
5,100,387 A	3/1992	Ng	5,376,083 A	12/1994	Mische
5,105,829 A	4/1992	Fabian et al.	5,377,678 A	1/1995	Dumoulin et al.
5,109,862 A	5/1992	Kelen et al.	5,385,053 A	1/1995	Wlodarczyk et al.
5,114,401 A	5/1992	Stuart et al.	5,385,146 A	1/1995	Goldreyer
5,121,750 A	6/1992	Katims	5,391,199 A	2/1995	Ben-Haim
5,125,410 A	6/1992	Misono et al.	5,394,876 A	3/1995	Ma
5,134,370 A	7/1992	Jefferts et al.	5,394,877 A	3/1995	Orr et al.
5,144,955 A	9/1992	O'Hara	5,395,366 A	3/1995	D'Andrea et al.
5,146,151 A	9/1992	Korn	5,398,683 A	3/1995	Edwards et al.
5,156,151 A	10/1992	Imran	5,398,691 A	3/1995	Martin et al.
5,158,086 A	10/1992	Brown et al.	5,411,485 A	5/1995	Tennican et al.
5,160,342 A	11/1992	Reger et al.	5,413,107 A	5/1995	Oakley et al.
5,161,536 A	11/1992	Vilkomerson et al.	5,417,208 A	5/1995	Winkler
5,174,295 A	12/1992	Christian et al.	5,417,701 A	5/1995	Holmes
5,174,299 A	12/1992	Nelson	5,422,478 A	6/1995	Wlodarczyk et al.
5,184,601 A	2/1993	Putman	5,423,334 A	6/1995	Jordan
5,184,627 A	2/1993	de Toledo	5,423,877 A	6/1995	Mackey
5,190,045 A	3/1993	Frazin	5,425,367 A	6/1995	Shapiro et al.
5,202,985 A	4/1993	Goyal	5,425,370 A	6/1995	Vilkomerson
5,205,830 A	4/1993	Dassa et al.	5,425,382 A	6/1995	Golden et al.
5,211,165 A	5/1993	Dumoulin et al.	5,427,114 A	6/1995	Colliver et al.
5,211,636 A	5/1993	Mische	5,429,132 A	7/1995	Guy et al.
5,212,988 A	5/1993	White et al.	5,429,617 A	7/1995	Hammersmark et al.
5,214,615 A	5/1993	Bauer et al.	5,431,641 A	7/1995	Grozinger et al.
5,217,026 A	6/1993	Stoy et al.	5,433,729 A	7/1995	Adams et al.
5,220,924 A	6/1993	Frazin	5,437,276 A	8/1995	Takada et al.
5,233,994 A	8/1993	Shmulewitz	5,437,277 A	8/1995	Dumoulin et al.
5,235,987 A	8/1993	Wolfe	5,438,873 A	8/1995	Wlodarczyk et al.
5,239,464 A	8/1993	Blair et al.	5,443,066 A	8/1995	Dumoulin et al.
5,240,004 A	8/1993	Walinsky et al.	5,443,489 A	8/1995	Ben-Haim
5,243,995 A	9/1993	Maier	5,445,150 A	8/1995	Dumoulin et al.
5,246,007 A	9/1993	Frisbie et al.	5,445,166 A	8/1995	Taylor
5,246,426 A	9/1993	Lewis et al.	5,450,846 A	9/1995	Goldreyer
5,247,171 A	9/1993	Wlodarczyk et al.	5,453,575 A	9/1995	O'Donnell et al.
5,251,635 A	10/1993	Dumoulin et al.	5,453,576 A	9/1995	Krivitski
5,255,680 A	10/1993	Darrow et al.	5,456,256 A	10/1995	Schneider
5,257,636 A	11/1993	White	5,456,718 A	10/1995	Szymaitis
5,257,979 A	11/1993	Jagpal	5,464,016 A	11/1995	Nicholas et al.
5,261,409 A	11/1993	Dardel	5,474,065 A	12/1995	Meathrel et al.
5,265,610 A	11/1993	Darrow et al.	5,476,090 A	12/1995	Kishi
5,265,614 A	11/1993	Hayakawa et al.	5,480,422 A	1/1996	Ben-Haim
5,267,569 A	12/1993	Lienhard	5,487,729 A	1/1996	Avellanet et al.
5,269,306 A	12/1993	Warnking et al.	5,490,522 A	2/1996	Dardel
5,270,810 A	12/1993	Nishimura	5,492,538 A	2/1996	Johlin, Jr.
5,271,404 A	12/1993	Corl et al.	5,494,038 A	2/1996	Wang et al.
5,273,025 A	12/1993	Sakiyama et al.	5,500,011 A	3/1996	Desai
5,273,042 A	12/1993	Lynch et al.	5,500,012 A	3/1996	Brucker et al.
5,274,551 A	12/1993	Corby, Jr.	5,505,205 A	4/1996	Solomon et al.
5,275,053 A	1/1994	Wlodarczyk et al.	5,509,822 A	4/1996	Negus et al.
5,279,129 A	1/1994	Ito	5,513,637 A	5/1996	Twiss et al.
5,279,607 A	1/1994	Schentag et al.	5,515,160 A	5/1996	Schulz et al.
5,280,786 A	1/1994	Wlodarczyk et al.	5,515,853 A	5/1996	Smith et al.
5,287,331 A	2/1994	Schindel et al.	5,517,989 A	5/1996	Frisbie et al.
5,289,373 A	2/1994	Zarge et al.	5,522,878 A	6/1996	Montecalvo et al.
5,292,342 A	3/1994	Nelson et al.	5,522,880 A	6/1996	Barone et al.
5,307,072 A	4/1994	Jones, Jr.	5,526,812 A	6/1996	Dumoulin et al.
5,311,871 A	5/1994	Yock	5,531,664 A	7/1996	Adachi et al.
5,313,949 A	5/1994	Yock	5,536,248 A	7/1996	Weaver et al.
5,318,025 A	6/1994	Dumoulin et al.	5,540,230 A	7/1996	Vilkomerson
5,325,860 A	7/1994	Seward et al.	5,540,681 A	7/1996	Strul et al.
5,325,873 A	7/1994	Hirschi et al.	5,542,938 A	8/1996	Avellanet et al.
5,330,496 A	7/1994	Alferness	5,546,949 A	8/1996	Frazin et al.
5,331,966 A	7/1994	Bennett et al.	5,546,951 A	8/1996	Ben-Haim
5,333,614 A	8/1994	Feiring	5,555,618 A	9/1996	Winkler
5,337,678 A	8/1994	Grout et al.	5,558,091 A	9/1996	Acker et al.
5,341,807 A	8/1994	Nardella	5,568,809 A	10/1996	Ben-haim
5,343,865 A	9/1994	Gardineer et al.	D375,450 S	11/1996	Bidwell et al.
5,345,940 A	9/1994	Seward et al.	5,570,671 A	11/1996	Hickey
5,348,020 A	9/1994	Hutson	5,575,291 A	11/1996	Hayakawa et al.
5,350,352 A	9/1994	Buchholtz et al.	5,588,442 A	12/1996	Scovil et al.
5,357,961 A	10/1994	Fields et al.	5,592,939 A	1/1997	Martinelli
			5,598,846 A	2/1997	Peszynski
			5,599,299 A	2/1997	Weaver et al.
			5,600,330 A	2/1997	Blood
			5,603,333 A	2/1997	Konings

(56)

References Cited

U.S. PATENT DOCUMENTS

5,610,967 A	3/1997	Moorman et al.	5,779,638 A	7/1998	Vesely et al.
5,617,866 A	4/1997	Marian, Jr.	5,782,767 A	7/1998	Pretlow, III
5,622,169 A	4/1997	Golden et al.	5,782,773 A	7/1998	Kuo et al.
5,622,170 A	4/1997	Schulz	5,785,657 A	7/1998	Breyer et al.
5,622,184 A	4/1997	Ashby et al.	5,792,055 A	8/1998	McKinnon et al.
5,623,931 A	4/1997	Wung et al.	5,795,297 A	8/1998	Daigle
5,624,430 A	4/1997	Eton et al.	5,795,298 A	8/1998	Vesely et al.
5,626,554 A	5/1997	Ryaby et al.	5,795,632 A	8/1998	Buchalter
5,626,870 A	5/1997	Monshipouri et al.	5,797,849 A	8/1998	Vesely et al.
5,630,419 A	5/1997	Ranalletta	5,800,352 A	9/1998	Ferre et al.
5,638,819 A	6/1997	Manwaring et al.	5,800,410 A	9/1998	Gawreluk
5,640,967 A	6/1997	Fine et al.	5,800,497 A	9/1998	Bakels et al.
5,644,612 A	7/1997	Moorman et al.	5,803,089 A	9/1998	Ferre et al.
5,645,065 A	7/1997	Shapiro et al.	5,810,733 A	9/1998	Van Creveld et al.
5,651,047 A	7/1997	Moorman et al.	RE35,924 E	10/1998	Winkler
5,654,864 A	8/1997	Ritter et al.	5,817,022 A	10/1998	Vesely
D383,968 S	9/1997	Bidwell et al.	5,817,024 A	10/1998	Ogle et al.
5,662,115 A	9/1997	Torp et al.	5,820,549 A	10/1998	Marian, Jr.
5,665,103 A	9/1997	Lafontaine et al.	5,820,560 A	10/1998	Sinderby et al.
5,665,477 A	9/1997	Meathrel et al.	5,824,031 A	10/1998	Cookston et al.
5,666,473 A	9/1997	Wallace	5,827,192 A	10/1998	Gopakumaran et al.
5,666,958 A	9/1997	Rothenberg et al.	5,829,444 A	11/1998	Ferre et al.
5,669,383 A	9/1997	Johnson	5,830,145 A	11/1998	Tenhoff
5,669,388 A	9/1997	Vilkomerson	5,831,260 A	11/1998	Hansen
5,676,159 A	10/1997	Navis	5,833,608 A	11/1998	Acker
5,676,673 A	10/1997	Ferre et al.	5,833,622 A	11/1998	Meathrel et al.
5,682,890 A	11/1997	Kormos et al.	5,835,561 A	11/1998	Moorman et al.
5,691,898 A	11/1997	Rosenberg et al.	5,836,882 A	11/1998	Frazin
5,694,945 A	12/1997	Ben-Haim	5,836,990 A	11/1998	Li
5,695,479 A	12/1997	Jagpal	5,840,024 A	11/1998	Taniguchi et al.
5,697,377 A	12/1997	Wittkamp	5,840,025 A	11/1998	Ben-Haim
5,699,801 A	12/1997	Atalar et al.	5,840,030 A	11/1998	Ferek-Petric et al.
5,700,889 A	12/1997	Blair	5,840,031 A	11/1998	Crowley
5,701,898 A	12/1997	Adam et al.	5,842,986 A	12/1998	Avrin et al.
5,702,433 A	12/1997	Taylor et al.	5,842,998 A	12/1998	Gopakumaran et al.
5,711,299 A	1/1998	Manwaring et al.	5,843,076 A	12/1998	Webster, Jr. et al.
5,713,362 A	2/1998	Vilkomerson	5,843,153 A	12/1998	Johnston et al.
5,713,363 A	2/1998	Seward et al.	5,844,140 A	12/1998	Seale
5,713,858 A	2/1998	Heruth et al.	5,846,198 A	12/1998	Killmann
5,713,946 A	2/1998	Ben-Haim	5,855,553 A	1/1999	Tajima et al.
5,715,817 A	2/1998	Stevens-Wright et al.	5,859,893 A	1/1999	Moorman et al.
5,716,389 A	2/1998	Walinsky et al.	5,865,748 A	2/1999	Co et al.
5,718,241 A	2/1998	Ben-Haim et al.	5,868,673 A	2/1999	Vesely
D391,838 S	3/1998	Bidwell et al.	5,873,822 A	2/1999	Ferre et al.
5,722,412 A	3/1998	Pflugrath et al.	5,876,328 A	3/1999	Fox et al.
5,727,550 A	3/1998	Montecalvo	5,879,297 A	3/1999	Haynor et al.
5,727,552 A	3/1998	Ryan	5,893,363 A	4/1999	Little et al.
5,727,553 A	3/1998	Saad	5,897,495 A	4/1999	Aida et al.
5,729,055 A	3/1998	Manning	5,899,860 A	5/1999	Pfeiffer et al.
5,729,129 A	3/1998	Acker	5,902,238 A	5/1999	Golden et al.
5,729,584 A	3/1998	Moorman et al.	5,907,487 A	5/1999	Rosenberg et al.
5,730,129 A	3/1998	Darrow et al.	5,908,385 A	6/1999	Chechelski et al.
5,731,996 A	3/1998	Gilbert	5,910,113 A	6/1999	Pruter
5,733,323 A	3/1998	Buck et al.	5,910,120 A	6/1999	Kim et al.
5,738,096 A	4/1998	Ben-Haim	5,913,820 A	6/1999	Bladen et al.
5,740,808 A	4/1998	Panescu et al.	5,913,830 A	6/1999	Miles
5,742,394 A	4/1998	Hansen	5,919,141 A	7/1999	Money et al.
5,744,953 A	4/1998	Hansen	5,919,170 A	7/1999	Woessner
5,748,767 A	5/1998	Raab	5,928,145 A	7/1999	Ocali et al.
5,749,835 A	5/1998	Glantz	5,929,607 A	7/1999	Rosenberg et al.
5,749,938 A	5/1998	Coombs	5,931,788 A	8/1999	Keen et al.
5,751,785 A	5/1998	Moorman et al.	5,931,818 A	8/1999	Werp et al.
5,752,513 A	5/1998	Acker et al.	5,931,863 A	8/1999	Griffin, III et al.
5,758,650 A	6/1998	Miller et al.	5,935,160 A	8/1999	Auricchio et al.
5,762,064 A	6/1998	Polvani	5,941,858 A	8/1999	Johnson
5,767,669 A	6/1998	Hansen et al.	5,941,889 A	8/1999	Cermak
5,767,960 A	6/1998	Orman et al.	5,941,904 A	8/1999	Johnston et al.
5,769,786 A	6/1998	Wiegel	5,944,022 A	8/1999	Nardella et al.
5,769,843 A	6/1998	Abela et al.	5,944,023 A	8/1999	Johnson et al.
5,769,881 A	6/1998	Schroepel et al.	5,951,472 A	9/1999	Van Vaals et al.
5,771,896 A	6/1998	Sliwa, Jr. et al.	5,951,598 A	9/1999	Bishay et al.
5,775,322 A	7/1998	Silverstein et al.	5,953,683 A	9/1999	Hansen et al.
5,775,332 A	7/1998	Goldman	5,957,857 A	9/1999	Hartley
5,776,064 A	7/1998	Kalfas et al.	5,961,923 A	10/1999	Nova et al.
5,776,080 A	7/1998	Thome et al.	5,967,978 A	10/1999	Littmann et al.
			5,967,980 A	10/1999	Ferre et al.
			5,967,991 A	10/1999	Gardineer et al.
			5,969,722 A	10/1999	Palm
			5,971,933 A	10/1999	Gopakumaran et al.

(56)

References Cited

U.S. PATENT DOCUMENTS

5,978,705 A	11/1999	KenKnight et al.	6,193,743 B1	2/2001	Brayton et al.
5,983,126 A	11/1999	Wittkampf	6,197,001 B1	3/2001	Wilson et al.
5,984,908 A	11/1999	Davis et al.	6,200,305 B1	3/2001	Berthiaume et al.
5,991,693 A	11/1999	Zalewski	6,203,499 B1	3/2001	Imling et al.
5,997,473 A	12/1999	Taniguchi et al.	6,208,884 B1	3/2001	Kumar et al.
5,997,481 A	12/1999	Adams et al.	6,211,626 B1	4/2001	Lys et al.
6,006,123 A	12/1999	Nguyen et al.	6,211,666 B1	4/2001	Acker
6,011,988 A	1/2000	Lynch et al.	6,212,426 B1	4/2001	Swanson
6,014,473 A	1/2000	Hossack et al.	6,216,027 B1	4/2001	Willis et al.
6,014,580 A	1/2000	Blume et al.	6,216,028 B1	4/2001	Haynor et al.
6,015,414 A	1/2000	Werp et al.	6,216,029 B1	4/2001	Paltieli
6,017,496 A	1/2000	Nova et al.	6,217,517 B1	4/2001	Grunwald
6,019,724 A	2/2000	Gronningsaeter et al.	6,223,087 B1	4/2001	Williams
6,019,725 A	2/2000	Vesely et al.	6,226,547 B1	5/2001	Lockhart et al.
6,022,342 A	2/2000	Mukherjee	6,230,042 B1	5/2001	Slettenmark
6,023,638 A	2/2000	Swanson	6,230,046 B1	5/2001	Crane et al.
6,026,312 A	2/2000	Shemwell et al.	6,231,518 B1	5/2001	Grabek et al.
6,031,765 A	2/2000	Lee et al.	6,233,476 B1	5/2001	Strommer et al.
6,032,070 A	2/2000	Flock et al.	6,233,994 B1	5/2001	Roy et al.
6,039,694 A	3/2000	Larson et al.	6,236,883 B1	5/2001	Ciaccio et al.
6,050,718 A	4/2000	Schena et al.	6,238,344 B1	5/2001	Gamelsky et al.
6,052,610 A	4/2000	Koch	6,241,673 B1	6/2001	Williams
6,052,618 A	4/2000	Dahlke et al.	6,246,231 B1	6/2001	Ashe
D424,693 S	5/2000	Pruter	6,246,898 B1	6/2001	Vesely et al.
6,058,323 A	5/2000	Lemelson	6,248,072 B1	6/2001	Murkin
6,059,718 A	5/2000	Taniguchi et al.	6,248,074 B1	6/2001	Ohno et al.
6,063,032 A	5/2000	Grunwald	6,248,075 B1	6/2001	McGee et al.
6,064,905 A	5/2000	Webster, Jr. et al.	6,249,234 B1	6/2001	Ely et al.
6,066,094 A	5/2000	Ben-Haim	6,253,770 B1	7/2001	Acker et al.
6,068,599 A	5/2000	Saito	6,254,543 B1	7/2001	Grunwald et al.
6,073,043 A	6/2000	Schneider	6,258,035 B1	7/2001	Hoeksel et al.
6,074,367 A	6/2000	Hubbell	6,259,938 B1	7/2001	Zarychta et al.
6,075,442 A	6/2000	Welch	6,259,941 B1	7/2001	Chia et al.
6,076,007 A	6/2000	England et al.	6,261,231 B1	7/2001	Damphousse et al.
6,081,737 A	6/2000	Shah	6,263,230 B1	7/2001	Haynor et al.
6,082,366 A	7/2000	Andra et al.	6,266,550 B1	7/2001	Selmon et al.
6,083,170 A	7/2000	Ben-Haim	6,266,551 B1	7/2001	Osadchy et al.
6,099,524 A	8/2000	Lipson et al.	6,266,552 B1	7/2001	Slettenmark
6,100,026 A	8/2000	Nova et al.	6,266,563 B1	7/2001	Kenknight et al.
6,102,044 A	8/2000	Naidyhorski	6,270,493 B1	8/2001	Lalonde et al.
6,102,862 A	8/2000	Grunwald et al.	6,271,833 B1	8/2001	Rosenberg et al.
6,107,699 A	8/2000	Swanson	6,272,371 B1	8/2001	Shlomo
6,112,111 A	8/2000	Glantz	6,272,374 B1	8/2001	Flock et al.
6,112,115 A	8/2000	Feldman et al.	6,275,258 B1	8/2001	Chim
6,113,504 A	9/2000	Kuesters	6,275,724 B1	8/2001	Dickinson et al.
6,115,624 A	9/2000	Lewis et al.	6,277,077 B1	8/2001	Brisken et al.
6,120,445 A	9/2000	Grunwald	6,284,459 B1	9/2001	Nova et al.
6,122,538 A	9/2000	Sliwa, Jr. et al.	6,285,898 B1	9/2001	Ben-Haim
6,128,174 A	10/2000	Ritter et al.	6,287,259 B1	9/2001	Grunwald
6,129,668 A	10/2000	Haynor et al.	6,287,260 B1	9/2001	Hascoet et al.
6,132,378 A	10/2000	Marino	6,288,704 B1	9/2001	Flack et al.
6,132,379 A	10/2000	Patacsil et al.	6,292,678 B1	9/2001	Hall et al.
6,135,961 A	10/2000	Pflugrath et al.	6,292,680 B1	9/2001	Somogyi et al.
6,136,274 A	10/2000	Nova et al.	6,292,901 B1	9/2001	Lys et al.
6,138,681 A	10/2000	Chen et al.	6,293,955 B1	9/2001	Houser et al.
6,139,496 A	10/2000	Chen et al.	6,296,604 B1	10/2001	Garibaldi et al.
6,139,502 A	10/2000	Fredriksen	6,298,261 B1	10/2001	Rex
6,139,540 A	10/2000	Rost et al.	6,304,768 B1	10/2001	Blume et al.
6,144,300 A	11/2000	Dames et al.	6,306,097 B1	10/2001	Park et al.
6,148,823 A	11/2000	Hastings	6,306,105 B1	10/2001	Rooney et al.
6,152,933 A	11/2000	Werp et al.	6,311,082 B1	10/2001	Creighton, IV et al.
6,157,853 A	12/2000	Blume et al.	6,315,709 B1	11/2001	Garibaldi et al.
6,165,144 A	12/2000	Talish et al.	6,315,727 B1	11/2001	Coleman et al.
6,165,977 A	12/2000	Mochly-Rosen	6,319,668 B1	11/2001	Nova et al.
6,166,496 A	12/2000	Lys et al.	6,323,769 B1	11/2001	Dames et al.
6,166,806 A	12/2000	Tjin	6,323,770 B1	11/2001	Dames et al.
6,167,765 B1	1/2001	Weitzel	6,324,416 B1	11/2001	Seibert
6,172,499 B1	1/2001	Ashe	6,325,540 B1	12/2001	Lounsbury et al.
6,173,199 B1	1/2001	Gabriel	6,325,762 B1	12/2001	Tjin
6,173,715 B1	1/2001	Sinanan et al.	6,329,139 B1	12/2001	Nova et al.
6,175,756 B1	1/2001	Ferre et al.	6,329,916 B1	12/2001	Dames et al.
6,176,829 B1	1/2001	Vilkomerson	6,330,467 B1	12/2001	Creighton, IV et al.
6,187,744 B1	2/2001	Rooney	6,332,089 B1	12/2001	Acker et al.
6,190,370 B1	2/2001	Tsui	6,332,874 B1	12/2001	Eliassen et al.
6,191,136 B1	2/2001	Marban	6,340,588 B1	1/2002	Nova et al.
			6,340,868 B1	1/2002	Lys et al.
			6,341,231 B1	1/2002	Ferre et al.
			6,346,081 B1	2/2002	Vilkomerson
			6,348,911 B1	2/2002	Rosenberg et al.

(56)

References Cited

U.S. PATENT DOCUMENTS

6,350,160 B1	2/2002	Feuersanger et al.	6,516,231 B1	2/2003	Flammang
6,352,363 B1	3/2002	Munger et al.	6,516,807 B1	2/2003	Panescu et al.
6,354,999 B1	3/2002	Dgany et al.	6,517,520 B2	2/2003	Chang et al.
6,355,026 B1	3/2002	Mick	6,522,906 B1	2/2003	Salisbury, Jr. et al.
6,356,791 B1	3/2002	Westlund et al.	6,522,907 B1	2/2003	Bladen et al.
6,360,123 B1	3/2002	Kimchi et al.	6,522,909 B1	2/2003	Garibaldi et al.
6,361,499 B1	3/2002	Bates et al.	6,524,303 B1	2/2003	Garibaldi
6,364,823 B1	4/2002	Garibaldi et al.	6,528,954 B1	3/2003	Lys et al.
6,364,839 B1	4/2002	Little et al.	6,528,991 B2	3/2003	Ashe
6,366,804 B1	4/2002	Mejia	6,529,761 B2	3/2003	Creighton, IV et al.
6,368,285 B1	4/2002	Osadchy et al.	6,529,766 B1	3/2003	Guendel
6,370,411 B1	4/2002	Osadchy et al.	6,534,982 B1	3/2003	Jakab
6,373,240 B1	4/2002	Govari	6,535,625 B1	3/2003	Chang et al.
6,373,388 B1	4/2002	Dames et al.	6,537,192 B1	3/2003	Elliott et al.
6,374,134 B1	4/2002	Bladen et al.	6,537,196 B1	3/2003	Creighton, IV et al.
6,374,670 B1	4/2002	Spelman et al.	6,538,634 B1	3/2003	Chui
6,375,606 B1	4/2002	Garibaldi et al.	6,540,699 B1	4/2003	Smith et al.
6,375,639 B1	4/2002	Duplessie et al.	6,542,766 B2	4/2003	Hall et al.
6,377,857 B1	4/2002	Brayton et al.	6,544,251 B1	4/2003	Crawford
6,379,302 B1	4/2002	Kessman et al.	6,545,678 B1	4/2003	Ohazama
6,379,303 B1	4/2002	Seitz et al.	6,546,270 B1	4/2003	Goldin et al.
6,379,307 B1	4/2002	Filly et al.	6,546,279 B1	4/2003	Bova et al.
6,381,485 B1	4/2002	Hunter et al.	6,546,787 B1	4/2003	Schiller et al.
6,385,472 B1	5/2002	Hall et al.	6,552,841 B1	4/2003	Lasser et al.
6,385,476 B1	5/2002	Osadchy et al.	6,556,858 B1	4/2003	Zeman
6,398,736 B1	6/2002	Seward	6,562,019 B1	5/2003	Sell
6,398,738 B1	6/2002	Millar	6,564,087 B1	5/2003	Pitris et al.
6,401,723 B1	6/2002	Garibaldi et al.	6,569,101 B2	5/2003	Quistgaard et al.
6,406,422 B1	6/2002	Landesberg	6,569,103 B2	5/2003	Hoeksel et al.
6,406,442 B1	6/2002	McFann et al.	6,569,160 B1	5/2003	Goldin et al.
6,412,978 B1	7/2002	Watanabe et al.	6,569,862 B1	5/2003	Marban
6,412,980 B1	7/2002	Lounsbury et al.	6,571,004 B1	5/2003	Florent et al.
6,417,839 B1	7/2002	Odell	6,574,518 B1	6/2003	Lounsbury et al.
6,418,332 B1	7/2002	Mastrototaro et al.	6,575,908 B2	6/2003	Barnes et al.
6,418,335 B2	7/2002	Avrin et al.	6,577,080 B2	6/2003	Lys et al.
6,423,002 B1	7/2002	Hossack	6,577,896 B2	6/2003	Werner et al.
6,423,050 B1	7/2002	Twardowski	6,584,343 B1	6/2003	Ransbury et al.
6,427,079 B1	7/2002	Schneider et al.	6,589,181 B2	7/2003	Grunwald et al.
6,428,551 B1	8/2002	Hall et al.	6,593,754 B1	7/2003	Steber et al.
6,430,315 B1	8/2002	Makram-Ebeid	6,593,884 B1	7/2003	Gilboa et al.
6,432,069 B1	8/2002	Godo et al.	6,597,943 B2	7/2003	Taha et al.
6,438,411 B1	8/2002	Guttman et al.	6,599,249 B1	7/2003	Nordgren et al.
6,442,416 B1	8/2002	Schultz	6,607,488 B1	8/2003	Jackson et al.
6,445,943 B1	9/2002	Ferre et al.	6,610,058 B2	8/2003	Flores
6,456,874 B1	9/2002	Hafer et al.	6,611,141 B1	8/2003	Schulz et al.
6,459,919 B1	10/2002	Lys et al.	6,615,071 B1	9/2003	Casscells, III et al.
6,463,121 B1	10/2002	Milnes	6,615,155 B2	9/2003	Gilboa
6,466,815 B1	10/2002	Saito et al.	6,616,610 B2	9/2003	Steininger et al.
6,471,656 B1	10/2002	Shalman et al.	6,618,612 B1	9/2003	Acker et al.
6,471,658 B1	10/2002	Daniels et al.	6,626,832 B1	9/2003	Paltieli et al.
6,471,700 B1	10/2002	Burbank et al.	6,626,834 B2	9/2003	Dunne et al.
6,473,167 B1	10/2002	Odell	6,626,902 B1	9/2003	Kucharczyk et al.
6,474,341 B1	11/2002	Hunter et al.	6,630,879 B1	10/2003	Creighton, IV et al.
6,475,152 B1	11/2002	Kelly, Jr. et al.	6,635,027 B1	10/2003	Cragg et al.
6,475,223 B1	11/2002	Werp et al.	6,645,148 B2	11/2003	Nguyen-Dinh et al.
6,477,402 B1	11/2002	Lynch et al.	6,648,875 B2	11/2003	Simpson et al.
6,484,118 B1	11/2002	Govari et al.	6,649,914 B1	11/2003	Moorman et al.
6,487,916 B1	12/2002	Gomm et al.	6,652,505 B1	11/2003	Tsugita
6,491,671 B1	12/2002	Larson, III et al.	6,652,506 B2	11/2003	Bowe et al.
6,493,573 B1	12/2002	Martinelli et al.	6,660,024 B1	12/2003	Flaherty et al.
6,494,832 B1	12/2002	Feldman et al.	6,662,034 B2	12/2003	Segner et al.
6,496,715 B1	12/2002	Lee et al.	6,663,661 B2	12/2003	Boneau
6,498,944 B1	12/2002	Ben-Haim et al.	6,666,828 B2	12/2003	Greco et al.
6,500,141 B1	12/2002	Irian et al.	6,672,308 B1	1/2004	Gaspari
6,505,062 B1	1/2003	Ritter et al.	6,677,752 B1	1/2004	Creighton, IV et al.
6,506,159 B2	1/2003	Hascoet et al.	6,679,857 B1	1/2004	Bastia et al.
6,507,751 B2	1/2003	Blume et al.	6,684,176 B2	1/2004	Willins et al.
6,508,802 B1	1/2003	Rosengart et al.	6,685,644 B2	2/2004	Sec
6,511,413 B2	1/2003	Landesberg	6,687,531 B1	2/2004	Ferre et al.
6,512,958 B1	1/2003	Swoyer et al.	6,689,119 B1	2/2004	Di Caprio et al.
6,514,202 B2	2/2003	Grunwald	6,690,963 B2	2/2004	Ben-Haim et al.
6,514,226 B1	2/2003	Levin et al.	6,690,964 B2	2/2004	Bieger et al.
6,514,249 B1	2/2003	Maguire et al.	6,690,968 B2	2/2004	Mejia
6,515,657 B1	2/2003	Zanelli	6,694,167 B1	2/2004	Ferre et al.
6,516,212 B1	2/2003	Bladen et al.	6,695,786 B2	2/2004	Wang et al.
			6,701,179 B1	3/2004	Martinelli et al.
			6,701,918 B2	3/2004	Fariss et al.
			6,702,804 B1	3/2004	Ritter et al.
			6,704,590 B2	3/2004	Haldeman

(56)

References Cited

U.S. PATENT DOCUMENTS

6,709,390	B1	3/2004	Pop	7,001,355	B2	2/2006	Nunomura et al.
6,711,429	B1	3/2004	Gilboa et al.	7,008,418	B2	3/2006	Hall et al.
6,711,431	B2	3/2004	Sarin et al.	7,010,338	B2	3/2006	Ritter et al.
6,719,699	B2	4/2004	Smith	7,015,393	B2	3/2006	Weiner et al.
6,719,724	B1	4/2004	Walker et al.	7,017,584	B2	3/2006	Garibaldi et al.
6,719,756	B1	4/2004	Muntermann	7,019,610	B2	3/2006	Creighton, IV et al.
6,720,745	B2	4/2004	Lys et al.	7,020,512	B2	3/2006	Ritter et al.
6,733,458	B1	5/2004	Steins et al.	D518,574	S	4/2006	Chaggares
6,733,511	B2	5/2004	Hall et al.	7,022,075	B2	4/2006	Grunwald et al.
6,736,782	B2	5/2004	Pfeiffer et al.	7,022,082	B2	4/2006	Sonek
6,738,656	B1	5/2004	Ferre et al.	7,026,927	B2	4/2006	Wright et al.
6,740,103	B2	5/2004	Hall et al.	7,027,634	B2	4/2006	Odell
6,743,177	B2	6/2004	Ito et al.	7,028,387	B1	4/2006	Huynh et al.
6,754,596	B2	6/2004	Ashe	7,029,446	B2	4/2006	Wendelken et al.
6,755,789	B2	6/2004	Stringer et al.	7,033,603	B2	4/2006	Nelson et al.
6,755,816	B2	6/2004	Ritter et al.	D520,139	S	5/2006	Chaggares
6,755,822	B2	6/2004	Reu et al.	D520,140	S	5/2006	Chaggares
6,757,557	B1	6/2004	Bladen et al.	7,038,398	B1	5/2006	Lys et al.
6,763,261	B2	7/2004	Casscells, III et al.	7,038,657	B2	5/2006	Rosenberg et al.
6,764,449	B2	7/2004	Lee et al.	7,043,293	B1	5/2006	Baura
6,768,496	B2	7/2004	Bieger et al.	7,048,733	B2	5/2006	Hartley et al.
6,772,001	B2	8/2004	Maschke et al.	7,054,228	B1	5/2006	Hickling
6,774,624	B2	8/2004	Anderson et al.	7,065,403	B1	6/2006	Mouchawar et al.
6,783,536	B2	8/2004	Vilsmeier et al.	7,066,914	B2	6/2006	Andersen
6,784,660	B2	8/2004	Ashe	7,066,924	B1	6/2006	Garibaldi et al.
6,785,571	B2	8/2004	Glossop et al.	7,069,072	B2	6/2006	Jansen et al.
6,786,219	B2	9/2004	Garibaldi et al.	D525,363	S	7/2006	Chaggares
6,786,870	B2	9/2004	Miyaki et al.	7,070,565	B2	7/2006	Vaezy et al.
6,788,967	B2	9/2004	Ben-Haim et al.	7,072,704	B2	7/2006	Bucholz
6,794,667	B2	9/2004	Noshi	7,082,325	B2	7/2006	Hashimshony et al.
6,799,066	B2	9/2004	Steines et al.	7,090,639	B2	8/2006	Govari
6,815,651	B2	11/2004	Odell	7,096,059	B2	8/2006	Geddes et al.
6,816,266	B2	11/2004	Varshneya et al.	7,096,148	B2	8/2006	Anderson et al.
6,817,364	B2	11/2004	Garibaldi	7,096,870	B2	8/2006	Lamprich et al.
6,834,201	B2	12/2004	Gillies et al.	7,098,907	B2	8/2006	Houston et al.
6,844,713	B2	1/2005	Steber et al.	7,103,205	B2	9/2006	Wang et al.
6,845,142	B2	1/2005	Ohishi	7,104,980	B1	9/2006	Laherty et al.
6,856,823	B2	2/2005	Ashe	7,106,043	B1	9/2006	Da Silva et al.
6,860,422	B2	3/2005	Hull et al.	7,106,431	B2	9/2006	Odell
6,862,467	B2	3/2005	Moore et al.	7,106,479	B2	9/2006	Roy et al.
6,869,390	B2	3/2005	Elliott et al.	7,107,105	B2	9/2006	Bjorklund et al.
6,875,179	B2	4/2005	Ferguson et al.	7,112,197	B2	9/2006	Hartley et al.
6,879,160	B2	4/2005	Jakab	7,128,734	B1	10/2006	Wilson et al.
6,887,206	B2	5/2005	Hoeksel et al.	7,132,804	B2	11/2006	Lys et al.
6,889,091	B2	5/2005	Hine et al.	7,137,976	B2	11/2006	Ritter et al.
6,895,268	B1	5/2005	Rahn et al.	7,141,019	B2	11/2006	Pearlman
6,902,528	B1	6/2005	Garibaldi et al.	7,141,812	B2	11/2006	Appleby et al.
6,905,469	B2	6/2005	Hascoet et al.	7,142,905	B2	11/2006	Slayton et al.
6,908,433	B1	6/2005	Pruter	7,148,970	B2	12/2006	de Boer
6,911,026	B1	6/2005	Hall et al.	7,153,291	B2	12/2006	Bierman
6,923,782	B2	8/2005	O'Mahony et al.	7,161,453	B2	1/2007	Creighton, IV
6,926,673	B2	8/2005	Roberts et al.	7,162,291	B1	1/2007	Nachaliel
6,926,674	B2	8/2005	Tenerz et al.	7,167,738	B2	1/2007	Schweikard et al.
6,934,575	B2	8/2005	Ferre et al.	7,169,107	B2	1/2007	Jersey-Willuhn et al.
6,936,010	B2	8/2005	Fang et al.	7,169,109	B2	1/2007	Jansen et al.
6,939,313	B2	9/2005	Saadat et al.	7,174,201	B2	2/2007	Govari et al.
6,940,379	B2	9/2005	Creighton	7,175,646	B2	2/2007	Brenneman et al.
6,941,166	B2	9/2005	MacAdam et al.	7,180,252	B2	2/2007	Lys et al.
6,945,938	B2	9/2005	Grunwald	7,184,820	B2	2/2007	Jersey-Willuhn et al.
6,947,788	B2	9/2005	Gilboa et al.	7,189,198	B2	3/2007	Harburn et al.
6,950,689	B1	9/2005	Willis et al.	7,189,205	B2	3/2007	McMorrow et al.
6,953,754	B2	10/2005	Machida et al.	7,189,208	B1	3/2007	Beatty et al.
6,958,677	B1	10/2005	Carter	7,190,819	B2	3/2007	Viswanathan
6,959,214	B2	10/2005	Pape et al.	7,194,295	B2	3/2007	Vilsmeier
6,962,566	B2	11/2005	Quistgaard et al.	7,204,798	B2	4/2007	Zdeblick et al.
6,968,846	B2	11/2005	Viswanathan	7,206,064	B2	4/2007	Rogers et al.
6,975,197	B2	12/2005	Creighton, IV	7,207,941	B2	4/2007	Sharf
6,976,962	B2	12/2005	Bullis	7,211,082	B2	5/2007	Hall et al.
6,976,987	B2	12/2005	Flores	7,214,191	B2	5/2007	Stringer et al.
6,980,843	B2	12/2005	Eng et al.	7,215,326	B2	5/2007	Rosenberg
6,980,852	B2	12/2005	Jersey-Willuhn et al.	7,221,104	B2	5/2007	Lys et al.
6,980,921	B2	12/2005	Anderson et al.	7,223,256	B2	5/2007	Bierman
6,986,739	B2	1/2006	Warren et al.	7,229,400	B2	6/2007	Elliott et al.
6,986,744	B1	1/2006	Krivitski	7,231,243	B2	6/2007	Tearney et al.
6,999,821	B2	2/2006	Jenney et al.	7,236,157	B2	6/2007	Schena et al.
				7,236,816	B2	6/2007	Kumar et al.
				7,236,820	B2	6/2007	Mabary et al.
				7,237,313	B2	7/2007	Skujins et al.
				7,241,267	B2	7/2007	Furia

(56)

References Cited

U.S. PATENT DOCUMENTS

7,244,234 B2	7/2007	Ridley et al.	7,819,810 B2	10/2010	Stringer et al.
7,248,032 B1	7/2007	Hular et al.	7,822,464 B2	10/2010	Maschke et al.
7,248,914 B2	7/2007	Hastings et al.	7,828,528 B2	11/2010	Estes et al.
7,252,633 B2	8/2007	Obata et al.	7,831,294 B2	11/2010	Viswanathan
7,261,691 B1	8/2007	Asomani	7,833,168 B2	11/2010	Taylor et al.
7,264,584 B2	9/2007	Ritter et al.	7,833,214 B2	11/2010	Wilson et al.
7,270,662 B2	9/2007	Visram et al.	7,840,252 B2	11/2010	Strommer et al.
7,276,044 B2	10/2007	Ferry et al.	D629,526 S	12/2010	Ladwig et al.
7,286,034 B2	10/2007	Creighton	D629,527 S	12/2010	Crunkilton
7,291,146 B2	11/2007	Steinke et al.	7,846,157 B2	12/2010	Kozel
7,297,140 B2	11/2007	Orlu et al.	7,850,613 B2	12/2010	Stribling
7,299,085 B2	11/2007	Bergelson et al.	D630,756 S	1/2011	Kitayama
7,300,430 B2	11/2007	Wilson et al.	D630,757 S	1/2011	Kitayama
7,302,288 B1	11/2007	Schellenberg	7,869,854 B2	1/2011	Shachar et al.
7,308,296 B2	12/2007	Lys et al.	7,869,865 B2	1/2011	Govari et al.
7,310,150 B2	12/2007	Guillermo et al.	7,873,402 B2	1/2011	Shachar
7,311,702 B2	12/2007	Tallarida et al.	7,909,815 B2	3/2011	Whitmore, III et al.
7,321,228 B2	1/2008	Govari	7,931,596 B2	4/2011	Rachlin et al.
7,326,241 B2	2/2008	Jang	7,947,040 B2	5/2011	Davies et al.
7,327,872 B2	2/2008	Vaillant et al.	7,969,142 B2	6/2011	Krueger et al.
7,331,462 B2	2/2008	Steppe	7,976,469 B2	7/2011	Bonde et al.
7,342,058 B2	3/2008	Peppmoller et al.	7,976,518 B2	7/2011	Shaughnessy et al.
7,349,732 B1	3/2008	Kil et al.	7,981,038 B2	7/2011	Kanade et al.
7,355,716 B2	4/2008	de Boer et al.	7,988,633 B2	8/2011	Hossack et al.
7,360,427 B2	4/2008	Drinkwater et al.	8,016,814 B2	9/2011	Blakstvedt et al.
7,366,376 B2	4/2008	Shishkov et al.	8,046,052 B2	10/2011	Verard et al.
7,366,562 B2	4/2008	Dukesherer et al.	8,055,327 B2	11/2011	Strommer et al.
7,366,563 B2	4/2008	Kleen et al.	8,057,394 B2	11/2011	Dala-Krishna
7,373,271 B1	5/2008	Schneider	8,060,185 B2	11/2011	Hunter et al.
7,381,204 B2	6/2008	Wilson et al.	8,078,274 B2	12/2011	Kassab
7,382,949 B2	6/2008	Bouma et al.	8,078,279 B2	12/2011	Dennis et al.
7,384,407 B2	6/2008	Rodriguez et al.	8,082,025 B2	12/2011	Amitai et al.
7,418,169 B2	8/2008	Tearney et al.	8,082,032 B2	12/2011	Kassab et al.
7,447,408 B2	11/2008	Bouma et al.	8,088,072 B2	1/2012	Munrow et al.
7,452,331 B1	11/2008	Pruter	8,090,430 B2	1/2012	Makower et al.
7,452,358 B2	11/2008	Stern et al.	8,099,161 B2	1/2012	Kassab
7,454,244 B2	11/2008	Kassab et al.	8,105,338 B2	1/2012	Anderson et al.
D585,556 S	1/2009	Kosaku	8,114,143 B2	2/2012	Kassab et al.
7,479,141 B2	1/2009	Kleen et al.	8,118,743 B2	2/2012	Park et al.
7,519,424 B2	4/2009	Dennis et al.	8,123,691 B2	2/2012	Mine et al.
7,529,584 B2	5/2009	Laske et al.	8,133,698 B2	3/2012	Silver
7,534,223 B2	5/2009	Boutilette et al.	8,142,417 B2	3/2012	Pajunk et al.
7,538,859 B2	5/2009	Tearney et al.	8,150,522 B2	4/2012	Echaz et al.
7,543,239 B2	6/2009	Viswanathan et al.	8,152,724 B2	4/2012	Ridley et al.
7,546,158 B2	6/2009	Allison et al.	8,155,732 B2	4/2012	Scholz et al.
7,547,282 B2	6/2009	Lo et al.	8,204,582 B2	6/2012	Zantos et al.
7,551,293 B2	6/2009	Yelin et al.	8,214,018 B2	7/2012	Markowitz et al.
D603,050 S	10/2009	Chen	8,221,402 B2	7/2012	Francischelli et al.
7,599,730 B2	10/2009	Hunter et al.	8,240,211 B2	8/2012	Zeitner et al.
7,606,615 B2	10/2009	Makower et al.	8,241,274 B2	8/2012	Keogh et al.
7,613,478 B2	11/2009	Jabri et al.	8,244,339 B2	8/2012	Shen et al.
7,616,992 B2	11/2009	Dennis et al.	8,255,035 B2	8/2012	Cao et al.
7,627,376 B2	12/2009	Dennis et al.	8,260,395 B2	9/2012	Markowitz et al.
7,635,336 B1	12/2009	Pruter	8,262,577 B2	9/2012	Munrow et al.
7,637,163 B2	12/2009	Fetzer et al.	8,298,149 B2	10/2012	Hastings et al.
7,640,053 B2	12/2009	Verin	8,303,502 B2	11/2012	Washburn et al.
7,651,469 B2	1/2010	Osborne et al.	8,303,505 B2	11/2012	Webler et al.
7,652,080 B2	1/2010	Peppmoller et al.	8,326,419 B2	12/2012	Rosenberg et al.
7,660,623 B2	2/2010	Hunter et al.	8,326,651 B2	12/2012	McLaren et al.
7,665,893 B2	2/2010	Buchalter	8,340,751 B2	12/2012	Markowitz et al.
7,666,191 B2	2/2010	Orban, III et al.	8,346,343 B2	1/2013	Kimura et al.
7,668,583 B2	2/2010	Fegert et al.	8,369,922 B2	2/2013	Paul et al.
7,697,972 B2	4/2010	Verard et al.	8,388,541 B2	3/2013	Messerly et al.
7,699,782 B2	4/2010	Angelsen et al.	8,388,546 B2	3/2013	Rothenberg
7,699,829 B2	4/2010	Harris et al.	8,391,956 B2	3/2013	Zellers et al.
7,715,925 B2	5/2010	Hafer et al.	8,400,164 B2	3/2013	Osadchy et al.
7,727,192 B2	6/2010	Tokumoto et al.	8,401,616 B2	3/2013	Verard et al.
7,729,743 B2	6/2010	Sabczynski et al.	8,409,103 B2	4/2013	Grunwald et al.
7,751,865 B2	7/2010	Jascob et al.	8,412,313 B2	4/2013	Amitai et al.
7,766,839 B2	8/2010	Rogers et al.	8,425,425 B2	4/2013	Hagy et al.
7,771,437 B2	8/2010	Hogg et al.	8,437,833 B2	5/2013	Silverstein
7,774,051 B2	8/2010	Voth	8,439,873 B1	5/2013	Donovan
7,774,055 B1	8/2010	Min	8,442,621 B2	5/2013	Gorek et al.
7,794,407 B2	9/2010	Rothenberg	8,447,384 B2	5/2013	Xu et al.
7,798,970 B2	9/2010	Lo et al.	D684,265 S	6/2013	Cadera
			8,456,182 B2	6/2013	Bar-Tal et al.
			8,478,382 B2	7/2013	Burnside et al.
			8,478,388 B2	7/2013	Nguyen et al.
			8,485,980 B2	7/2013	Sinderby et al.

(56)

References Cited

U.S. PATENT DOCUMENTS

8,494,608 B2	7/2013	Markowitz et al.	2002/0165534 A1	11/2002	Hayzelden et al.
8,496,592 B2	7/2013	Ridley et al.	2002/0165537 A1	11/2002	Kelley et al.
8,504,139 B2	8/2013	Jacobsen et al.	2002/0173721 A1	11/2002	Grunwald et al.
8,512,256 B2	8/2013	Rothenberg	2002/0193756 A1	12/2002	Prindle
8,521,122 B2	8/2013	Scott et al.	2002/0198568 A1	12/2002	Hafer et al.
8,527,036 B2	9/2013	Jalde et al.	2003/0009132 A1	1/2003	Schwartz et al.
8,538,509 B2	9/2013	Harley et al.	2003/0011359 A1	1/2003	Ashe
8,597,193 B2	12/2013	Grunwald et al.	2003/0013959 A1	1/2003	Grunwald et al.
8,620,412 B2	12/2013	Griffiths et al.	2003/0013966 A1	1/2003	Barnes et al.
8,644,907 B2	2/2014	Hartmann et al.	2003/0013986 A1	1/2003	Saadat
8,663,116 B2	3/2014	Hamilton, Jr.	2003/0018251 A1	1/2003	Solomon
8,690,776 B2	4/2014	Razzaque et al.	2003/0036696 A1	2/2003	Willis et al.
8,700,137 B2	4/2014	Albert	2003/0040671 A1	2/2003	Somogyi et al.
8,715,195 B2	5/2014	Ziv	2003/0040743 A1	2/2003	Cosman et al.
8,721,655 B2	5/2014	Viswanathan et al.	2003/0072805 A1	4/2003	Miyazawa et al.
8,734,440 B2	5/2014	Wu	2003/0073901 A1	4/2003	Simon et al.
8,761,862 B2	6/2014	Ridley et al.	2003/0076281 A1	4/2003	Morgan et al.
8,774,907 B2	7/2014	Rothenberg	2003/0083698 A1	5/2003	Whitehurst et al.
8,781,555 B2	7/2014	Burnside et al.	2003/0088195 A1	5/2003	Vardi et al.
8,784,336 B2	7/2014	Bown et al.	2003/0092993 A1	5/2003	Grunwald
8,801,693 B2	8/2014	He et al.	2003/0100849 A1	5/2003	Jang
8,849,382 B2	9/2014	Cox et al.	2003/0114742 A1	6/2003	Lewkowicz et al.
8,858,455 B2	10/2014	Rothenberg	2003/0114777 A1	6/2003	Griffin et al.
8,934,961 B2	1/2015	Lakin et al.	2003/0120150 A1	6/2003	Govari
8,942,784 B2	1/2015	Neidert et al.	2003/0120154 A1	6/2003	Sauer et al.
8,965,490 B2	2/2015	Lee et al.	2003/0139661 A1	7/2003	Kimchy et al.
8,971,994 B2	3/2015	Burnside et al.	2003/0149328 A1	8/2003	Elliott et al.
9,014,794 B2	4/2015	Brodnick et al.	2003/0149368 A1	8/2003	Hennemann et al.
9,033,889 B2	5/2015	Hamilton, Jr.	2003/0152290 A1	8/2003	Odell
9,125,578 B2	9/2015	Grunwald	2003/0160721 A1	8/2003	Gilboa et al.
9,179,860 B2	11/2015	Markowitz et al.	2003/0162414 A1 *	8/2003	Schulz A61B 5/02427 439/11
9,198,600 B2	12/2015	Grunwald et al.	2003/0163037 A1	8/2003	Bladen et al.
9,339,206 B2	5/2016	Grunwald	2003/0163142 A1	8/2003	Paltieli et al.
9,415,188 B2	8/2016	He	2003/0171691 A1	9/2003	Casscells et al.
9,456,766 B2	10/2016	Cox et al.	2003/0173953 A1	9/2003	Ashe
9,492,097 B2	11/2016	Wilkes et al.	2003/0181892 A1	9/2003	Pajunk et al.
9,521,961 B2	12/2016	Silverstein et al.	2003/0184544 A1	10/2003	Prudent
9,526,440 B2	12/2016	Burnside et al.	2003/0191392 A1	10/2003	Haldeman
9,532,724 B2	1/2017	Grunwald	2003/0191460 A1	10/2003	Hobbs et al.
9,554,716 B2	1/2017	Burnside et al.	2003/0195420 A1	10/2003	Mendlein et al.
9,636,031 B2	5/2017	Cox	2003/0199746 A1	10/2003	Fuimaono et al.
9,642,986 B2	5/2017	Beasley	2003/0208142 A1	11/2003	Boudewijn et al.
9,649,048 B2	5/2017	Cox et al.	2003/0216639 A1	11/2003	Gilboa et al.
9,681,823 B2	6/2017	Messerly et al.	2003/0220557 A1	11/2003	Cleary et al.
9,833,169 B2	12/2017	Rothenberg	2003/0220578 A1	11/2003	Ho et al.
9,839,372 B2	12/2017	Bukhman et al.	2003/0229298 A1	12/2003	Iwami et al.
9,901,714 B2	2/2018	Lemon et al.	2003/0233042 A1	12/2003	Ashe
9,907,513 B2	3/2018	Silverstein	2003/0236445 A1	12/2003	Couvillon
9,999,371 B2	6/2018	Messerly et al.	2004/0010189 A1	1/2004	van Sloun et al.
10,004,875 B2	6/2018	Bown et al.	2004/0015070 A1	1/2004	Liang et al.
10,046,139 B2	8/2018	Powers et al.	2004/0024301 A1	2/2004	Hackett et al.
10,105,121 B2	10/2018	Burnside et al.	2004/0030319 A1	2/2004	Korkor et al.
10,165,962 B2	1/2019	Messerly et al.	2004/0054278 A1	3/2004	Kimchy
10,231,643 B2	3/2019	Grunwald	2004/0059217 A1	3/2004	Kessman et al.
10,231,753 B2	3/2019	Burnside et al.	2004/0059237 A1	3/2004	Narayan et al.
10,238,418 B2	3/2019	Cox et al.	2004/0082916 A1	4/2004	Jenkins
10,271,762 B2	4/2019	Grunwald	2004/0087877 A1	5/2004	Besz et al.
2001/0014774 A1	8/2001	Grunwald	2004/0088136 A1	5/2004	Ashe
2001/0027332 A1	10/2001	Grunwald et al.	2004/0092962 A1	5/2004	Thornton et al.
2002/0010392 A1	1/2002	Desai	2004/0097803 A1	5/2004	Panescu
2002/0016549 A1	2/2002	Mejia	2004/0097804 A1	5/2004	Sobe
2002/0019447 A1	2/2002	Renn et al.	2004/0097805 A1	5/2004	Verard et al.
2002/0022777 A1	2/2002	Crieghton et al.	2004/0097806 A1	5/2004	Hunter et al.
2002/0032391 A1	3/2002	McFann et al.	2004/0116809 A1	6/2004	Chow et al.
2002/0049488 A1	4/2002	Boneau	2004/0127805 A1	7/2004	MacAdam et al.
2002/0055680 A1	5/2002	Miele et al.	2004/0131998 A1	7/2004	Marom et al.
2002/0082559 A1	6/2002	Chang et al.	2004/0133111 A1	7/2004	Szcezech et al.
2002/0113555 A1	8/2002	Lys et al.	2004/0133130 A1	7/2004	Ferry et al.
2002/0123679 A1	9/2002	Dominguez	2004/0135069 A1	7/2004	Odell
2002/0128554 A1	9/2002	Seward	2004/0138557 A1	7/2004	Le et al.
2002/0129952 A1	9/2002	Matsudate et al.	2004/0138564 A1	7/2004	Hwang et al.
2002/0133079 A1	9/2002	Sandhu	2004/0138569 A1	7/2004	Grunwald et al.
2002/0156363 A1	10/2002	Hunter et al.	2004/0138570 A1	7/2004	Nita et al.
2002/0156376 A1	10/2002	Wang et al.	2004/0147837 A1	7/2004	Macaulay et al.
2002/0165448 A1	11/2002	Ben-Haim et al.	2004/0150963 A1	8/2004	Holmberg et al.
			2004/0152972 A1	8/2004	Hunter
			2004/0155609 A1	8/2004	Lys et al.
			2004/0158140 A1	8/2004	Fuimaono et al.

(56)

References Cited

U.S. PATENT DOCUMENTS

2004/0171924	A1	9/2004	Mire et al.	2006/0015003	A1	1/2006	Moaddes et al.
2004/0176688	A1	9/2004	Haldeman	2006/0025677	A1	2/2006	Verard et al.
2004/0186461	A1	9/2004	DiMatteo	2006/0025697	A1	2/2006	Kurzweil et al.
2004/0199069	A1	10/2004	Connelly et al.	2006/0058633	A1	3/2006	Hoshino et al.
2004/0210289	A1	10/2004	Wang et al.	2006/0068074	A1	3/2006	Stefandl
2004/0225233	A1	11/2004	Frankowski et al.	2006/0084867	A1	4/2006	Tremblay et al.
2004/0230131	A1	11/2004	Kassab et al.	2006/0106306	A1	5/2006	Essner et al.
2004/0230271	A1	11/2004	Wang et al.	2006/0116571	A1	6/2006	Maschke et al.
2004/0234453	A1	11/2004	Smith	2006/0116576	A1	6/2006	McGee et al.
2004/0243018	A1	12/2004	Organ et al.	2006/0116578	A1	6/2006	Grunwald et al.
2004/0243116	A1	12/2004	Joye et al.	2006/0122514	A1	6/2006	Byrd et al.
2004/0243118	A1	12/2004	Ayers et al.	2006/0142656	A1	6/2006	Malackowski et al.
2004/0253365	A1	12/2004	Warren	2006/0149134	A1	7/2006	Soper et al.
2004/0254470	A1	12/2004	Drinkwater et al.	2006/0173251	A1	8/2006	Govari et al.
2004/0254495	A1	12/2004	Mabary et al.	2006/0173329	A1	8/2006	Irioka et al.
2004/0260174	A1	12/2004	Keene	2006/0173407	A1	8/2006	Shaughnessy et al.
2004/0267086	A1	12/2004	Anstadt et al.	2006/0176242	A1	8/2006	Jaramaz et al.
2005/0004450	A1	1/2005	Ben-Haim et al.	2006/0184074	A1	8/2006	Vaezy et al.
2005/0021019	A1	1/2005	Hashimshony et al.	2006/0206037	A1	9/2006	Braxton
2005/0033150	A1	2/2005	Takahashi et al.	2006/0211944	A1	9/2006	Mauge et al.
2005/0038355	A1	2/2005	Gellman et al.	2006/0217655	A1	9/2006	Vitullo et al.
2005/0043640	A1	2/2005	Chang	2006/0217755	A1	9/2006	Eversull et al.
2005/0049486	A1	3/2005	Urquhart et al.	2006/0224188	A1	10/2006	Libbus et al.
2005/0049510	A1	3/2005	Haldeman et al.	2006/0241432	A1	10/2006	Herline et al.
2005/0063194	A1	3/2005	Lys et al.	2006/0247746	A1	11/2006	Danek et al.
2005/0070788	A1	3/2005	Wilson et al.	2006/0253029	A1	11/2006	Altmann et al.
2005/0075561	A1	4/2005	Golden	2006/0253115	A1	11/2006	Avitall et al.
2005/0085715	A1	4/2005	Dukesherer et al.	2006/0258895	A1	11/2006	Maschke
2005/0085716	A1	4/2005	Hamm et al.	2006/0276867	A1	12/2006	Viswanathan
2005/0085718	A1	4/2005	Shahidi	2006/0287595	A1	12/2006	Maschke
2005/0085720	A1	4/2005	Jascob et al.	2007/0010753	A1	1/2007	MacAdam
2005/0090746	A1	4/2005	Ohtake	2007/0016007	A1	1/2007	Govari et al.
2005/0101868	A1	5/2005	Ridley et al.	2007/0016013	A1	1/2007	Camus
2005/0101869	A1	5/2005	Burba et al.	2007/0016068	A1	1/2007	Grunwald et al.
2005/0105081	A1	5/2005	Odell	2007/0016069	A1	1/2007	Grunwald et al.
2005/0105101	A1	5/2005	Duling et al.	2007/0016070	A1	1/2007	Grunwald et al.
2005/0112135	A1	5/2005	Cormier et al.	2007/0016072	A1	1/2007	Grunwald et al.
2005/0113669	A1	5/2005	Helfer et al.	2007/0032746	A1	2/2007	Sell
2005/0113676	A1	5/2005	Weiner et al.	2007/0038113	A1	2/2007	Donuki et al.
2005/0113700	A1	5/2005	Yanagihara et al.	2007/0049817	A1	3/2007	Preiss et al.
2005/0113873	A1	5/2005	Weiner et al.	2007/0049822	A1	3/2007	Bunce et al.
2005/0113874	A1	5/2005	Connelly et al.	2007/0049846	A1	3/2007	Bown et al.
2005/0113876	A1	5/2005	Weiner et al.	2007/0055141	A1	3/2007	Kruger et al.
2005/0148836	A1	7/2005	Kleen et al.	2007/0055142	A1	3/2007	Webler
2005/0148902	A1	7/2005	Minar et al.	2007/0055294	A1	3/2007	Giap
2005/0149002	A1	7/2005	Wang et al.	2007/0060992	A1	3/2007	Pappone
2005/0151489	A1	7/2005	Lys et al.	2007/0062544	A1	3/2007	Bergstrom et al.
2005/0154308	A1	7/2005	Quistgaard et al.	2007/0066888	A1	3/2007	Maschke
2005/0159644	A1	7/2005	Takano	2007/0073155	A1	3/2007	Park et al.
2005/0159790	A1	7/2005	Shalev	2007/0078343	A1	4/2007	Kawashima et al.
2005/0165301	A1	7/2005	Smith et al.	2007/0087038	A1	4/2007	Richardson et al.
2005/0165313	A1	7/2005	Byron et al.	2007/0093710	A1	4/2007	Maschke
2005/0175665	A1	8/2005	Hunter et al.	2007/0100236	A1	5/2007	McMorrow et al.
2005/0175703	A1	8/2005	Hunter et al.	2007/0100285	A1	5/2007	Griffin et al.
2005/0178395	A1	8/2005	Hunter et al.	2007/0112282	A1	5/2007	Skujins et al.
2005/0178396	A1	8/2005	Hunter et al.	2007/0123805	A1	5/2007	Shireman et al.
2005/0182295	A1	8/2005	Soper et al.	2007/0129770	A1	6/2007	Younis
2005/0182454	A1	8/2005	Gharib et al.	2007/0135803	A1	6/2007	Belson
2005/0197674	A1	9/2005	McCabe et al.	2007/0135886	A1	6/2007	Maschke
2005/0203368	A1	9/2005	Verin	2007/0156205	A1	7/2007	Larson et al.
2005/0203396	A1	9/2005	Angelsen et al.	2007/0161853	A1	7/2007	Yagi et al.
2005/0205081	A1	9/2005	Barker et al.	2007/0161914	A1	7/2007	Zdeblick et al.
2005/0215901	A1	9/2005	Anderson et al.	2007/0161915	A1	7/2007	Desai
2005/0215945	A1	9/2005	Harris et al.	2007/0167738	A1	7/2007	Timinger et al.
2005/0222532	A1	10/2005	Bertolero et al.	2007/0167762	A1	7/2007	Kim et al.
2005/0240102	A1	10/2005	Rachlin et al.	2007/0167769	A1	7/2007	Ikuma et al.
2005/0245811	A1	11/2005	Scheffler	2007/0167801	A1	7/2007	Webler et al.
2005/0256398	A1	11/2005	Hastings et al.	2007/0167997	A1	7/2007	Forsberg et al.
2005/0256451	A1	11/2005	Adams et al.	2007/0197891	A1	8/2007	Shachar et al.
2005/0256521	A1	11/2005	Kozel	2007/0197905	A1	8/2007	Timinger et al.
2005/0256541	A1	11/2005	Stypulkowski	2007/0197926	A1	8/2007	Danehorn et al.
2005/0283210	A1	12/2005	Blischak et al.	2007/0208255	A1	9/2007	Ridley et al.
2005/0283216	A1	12/2005	Pyles	2007/0219453	A1	9/2007	Kremliovsky et al.
2005/0288586	A1	12/2005	Ferek-Petric	2007/0225589	A1	9/2007	Viswanathan
2006/0009759	A1	1/2006	Christian et al.	2007/0225610	A1	9/2007	Mickley et al.
				2007/0232882	A1	10/2007	Glossop et al.
				2007/0232896	A1	10/2007	Gilboa et al.
				2007/0238984	A1	10/2007	Maschke et al.
				2007/0239004	A1	10/2007	Kakee et al.

(56)		References Cited			
		U.S. PATENT DOCUMENTS		2009/0124901 A1	5/2009 Fink et al.
				2009/0143736 A1	6/2009 Mittermeyer et al.
				2009/0156926 A1*	6/2009 Messerly A61B 5/042 600/409
2007/0239018 A1	10/2007	Fetzer et al.	2009/0163810 A1	6/2009	Kanade et al.
2007/0244413 A1	10/2007	Biggins	2009/0171217 A1	7/2009	Kim et al.
2007/0247454 A1	10/2007	Rahn et al.	2009/0177083 A1	7/2009	Matsumura
2007/0249911 A1	10/2007	Simon	2009/0177090 A1	7/2009	Grunwald et al.
2007/0255270 A1	11/2007	Carney	2009/0203989 A1	8/2009	Burnside et al.
2007/0265526 A1	11/2007	Govari et al.	2009/0204113 A1	8/2009	MacAdam et al.
2007/0280974 A1	12/2007	Son et al.	2009/0209872 A1	8/2009	Pop
2007/0282196 A1	12/2007	Birk et al.	2009/0209950 A1	8/2009	Starksen
2007/0282197 A1	12/2007	Bill et al.	2009/0221908 A1	9/2009	Glossop
2007/0299352 A1	12/2007	Harlev et al.	2009/0227952 A1	9/2009	Blakstvedt et al.
2007/0299353 A1	12/2007	Harlev et al.	2009/0234328 A1*	9/2009	Cox A61B 5/042 604/523
2008/0004652 A1	1/2008	Abboud et al.	2009/0253976 A1	10/2009	Harley et al.
2008/0008745 A1	1/2008	Stinchcomb et al.	2009/0258171 A1	10/2009	Uang
2008/0009720 A1	1/2008	Schefelker et al.	2009/0259124 A1	10/2009	Rothenberg
2008/0015442 A1	1/2008	Watson et al.	2009/0262982 A1	10/2009	Markowitz et al.
2008/0027320 A1	1/2008	Bolorforosh et al.	2009/0270729 A1	10/2009	Corbucci et al.
2008/0033282 A1	2/2008	Bar-Tal et al.	2009/0270746 A1	10/2009	Min
2008/0033283 A1	2/2008	Dellaca et al.	2009/0275828 A1	11/2009	Shachar et al.
2008/0033316 A1	2/2008	Kassab et al.	2009/0281419 A1	11/2009	Troesken et al.
2008/0033350 A1	2/2008	Wilson et al.	2009/0297441 A1	12/2009	Canham et al.
2008/0045908 A1	2/2008	Gould et al.	2009/0312629 A1	12/2009	Razzaque et al.
2008/0051626 A1	2/2008	Sato et al.	2010/0004543 A1	1/2010	Ahlund et al.
2008/0077158 A1	3/2008	Haider et al.	2010/0004547 A1	1/2010	Scholz et al.
2008/0081958 A1	4/2008	Denison et al.	2010/0010355 A1	1/2010	Kassab
2008/0082136 A1	4/2008	Gaudiani	2010/0010444 A1	1/2010	Bettuchi
2008/0097232 A1	4/2008	Rothenberg	2010/0010612 A1	1/2010	Gelbart et al.
2008/0108949 A1	5/2008	Beasley et al.	2010/0016726 A1	1/2010	Meier
2008/0114095 A1	5/2008	Peppmoller et al.	2010/0036227 A1	2/2010	Cox et al.
2008/0119697 A1	5/2008	Vadodaria et al.	2010/0036284 A1	2/2010	Laynes et al.
2008/0125772 A1	5/2008	Stone et al.	2010/0041973 A1	2/2010	Vu et al.
2008/0137927 A1	6/2008	Altmann et al.	2010/0041984 A1	2/2010	Shapland et al.
2008/0139944 A1	6/2008	Weymer et al.	2010/0049062 A1	2/2010	Ziv
2008/0146939 A1	6/2008	McMorrow et al.	2010/0055153 A1	3/2010	Majmudar
2008/0146940 A1	6/2008	Jenkins et al.	2010/0055184 A1	3/2010	Zeitels et al.
2008/0146941 A1	6/2008	Dala-Krishna	2010/0057157 A1	3/2010	Govari et al.
2008/0146942 A1	6/2008	Dala-Krishna	2010/0060472 A1	3/2010	Kimura et al.
2008/0154100 A1	6/2008	Thalmeier et al.	2010/0063401 A1	3/2010	Nishina et al.
2008/0166453 A1	7/2008	Steele et al.	2010/0076305 A1	3/2010	Maier-Hein et al.
2008/0171934 A1	7/2008	Greenan et al.	2010/0076328 A1	3/2010	Matsumura et al.
2008/0183075 A1	7/2008	Govari et al.	2010/0081934 A1	4/2010	Soltani et al.
2008/0188830 A1	8/2008	Rosenblatt et al.	2010/0083719 A1	4/2010	Peppmoller et al.
2008/0190438 A1	8/2008	Harley et al.	2010/0094116 A1	4/2010	Silverstein
2008/0195169 A1	8/2008	Pinter et al.	2010/0106011 A1	4/2010	Byrd et al.
2008/0200754 A1	8/2008	Buchalter	2010/0113917 A1	5/2010	Anderson
2008/0200801 A1	8/2008	Wildes et al.	2010/0114573 A1	5/2010	Huang et al.
2008/0200913 A1	8/2008	Viswanathan	2010/0117659 A1	5/2010	Osadchy et al.
2008/0228082 A1	9/2008	Scheirer et al.	2010/0130858 A1	5/2010	Arai et al.
2008/0236598 A1	10/2008	Gobel	2010/0143119 A1	6/2010	Kooijman et al.
2008/0255404 A1	10/2008	Nogawa et al.	2010/0152596 A1	6/2010	Griffiths et al.
2008/0255475 A1	10/2008	Kondrosky et al.	2010/0152604 A1	6/2010	Kaula et al.
2008/0269581 A1	10/2008	Wood et al.	2010/0160772 A1	6/2010	Gardeski et al.
2008/0269611 A1	10/2008	Pedrizzetti et al.	2010/0168557 A1	7/2010	Deno et al.
2008/0275465 A1	11/2008	Paul et al.	2010/0185097 A1	7/2010	Hall
2008/0275765 A1	11/2008	Kuchar	2010/0198048 A1	8/2010	Togawa
2008/0288038 A1	11/2008	Paul et al.	2010/0198346 A1	8/2010	Keogh et al.
2008/0294041 A1	11/2008	Kassab	2010/0204569 A1	8/2010	Burnside et al.
2008/0319350 A1	12/2008	Wallace et al.	2010/0204614 A1	8/2010	Lindquist et al.
2009/0005674 A1	1/2009	Saadat et al.	2010/0210938 A1	8/2010	Verard et al.
2009/0005675 A1	1/2009	Grunwald et al.	2010/0210950 A1	8/2010	Dunbar et al.
2009/0018497 A1	1/2009	Birchard et al.	2010/0217116 A1	8/2010	Eck et al.
2009/0024018 A1	1/2009	Boyden et al.	2010/0222664 A1	9/2010	Lemon et al.
2009/0030380 A1	1/2009	Binmoeller	2010/0222786 A1	9/2010	Kassab
2009/0043205 A1	2/2009	Pelissier et al.	2010/0234724 A1	9/2010	Jacobsen et al.
2009/0062646 A1	3/2009	Creighton, IV et al.	2010/0234733 A1	9/2010	Wahlheim
2009/0062684 A1	3/2009	Gregersen et al.	2010/0249598 A1	9/2010	Smith et al.
2009/0062772 A1	3/2009	Wakeford et al.	2010/0258033 A1	10/2010	Yang et al.
2009/0080738 A1	3/2009	Zur et al.	2010/0268059 A1	10/2010	Ryu et al.
2009/0082661 A1	3/2009	Saladin et al.	2010/0273895 A1	10/2010	Stinchcomb et al.
2009/0084382 A1	4/2009	Jalde et al.	2010/0274150 A1	10/2010	Harley et al.
2009/0099468 A1	4/2009	Thiagalingam et al.	2010/0291521 A1	11/2010	Simon
2009/0101577 A1	4/2009	Fulkerson et al.	2010/0298702 A1	11/2010	Rogers et al.
2009/0115406 A1	5/2009	Anderson et al.	2010/0298704 A1	11/2010	Pelissier et al.
2009/0118612 A1	5/2009	Grunwald et al.	2010/0298705 A1	11/2010	Pelissier et al.
2009/0118637 A1	5/2009	Kassab et al.	2010/0298712 A1	11/2010	Pelissier et al.
2009/0118706 A1	5/2009	Schweikert et al.			

(56)

References Cited

U.S. PATENT DOCUMENTS

- | | | | | | | | |
|--------------|----|---------|--------------------|--------------|----|---------|----------------------------|
| 2010/0312086 | A9 | 12/2010 | Beatty et al. | 2013/0303896 | A1 | 11/2013 | Kalpin et al. |
| 2010/0317981 | A1 | 12/2010 | Grunwald | 2013/0303945 | A1 | 11/2013 | Blumenkranz et al. |
| 2010/0318026 | A1 | 12/2010 | Grunwald | 2013/0317338 | A1 | 11/2013 | Silverstein |
| 2010/0331712 | A1 | 12/2010 | Rothenberg | 2013/0324841 | A1 | 12/2013 | Kamen et al. |
| 2011/0015496 | A1 | 1/2011 | Sherman et al. | 2013/0338503 | A1 | 12/2013 | Cohen et al. |
| 2011/0015527 | A1 | 1/2011 | Heasty et al. | 2013/0338517 | A1 | 12/2013 | Rothenberg |
| 2011/0015533 | A1 | 1/2011 | Cox et al. | 2013/0345555 | A1 | 12/2013 | Kanade et al. |
| 2011/0034823 | A1 | 2/2011 | Gelbart et al. | 2014/0031674 | A1 | 1/2014 | Newman et al. |
| 2011/0034940 | A1 | 2/2011 | Payner | 2014/0046261 | A1 | 2/2014 | Newman et al. |
| 2011/0040212 | A1 | 2/2011 | Dietz et al. | 2014/0089836 | A1 | 3/2014 | Damani et al. |
| 2011/0052694 | A1 | 3/2011 | Stinchcomb et al. | 2014/0094694 | A1 | 4/2014 | Moctezuma de la Barrera |
| 2011/0087105 | A1 | 4/2011 | Ridley et al. | 2014/0094768 | A1 | 4/2014 | Stangenes et al. |
| 2011/0087106 | A1 | 4/2011 | Ridley et al. | 2014/0107475 | A1 | 4/2014 | Cox et al. |
| 2011/0087107 | A1 | 4/2011 | Lindekugel et al. | 2014/0128712 | A1 | 5/2014 | Banet et al. |
| 2011/0106101 | A1 | 5/2011 | Tortonese et al. | 2014/0163356 | A2 | 6/2014 | Burnside et al. |
| 2011/0112396 | A1 | 5/2011 | Shachar et al. | 2014/0180074 | A1 | 6/2014 | Green et al. |
| 2011/0136242 | A1 | 6/2011 | Marx et al. | 2014/0187917 | A1 | 7/2014 | Clark et al. |
| 2011/0137156 | A1 | 6/2011 | Razzaque et al. | 2014/0187990 | A1 | 7/2014 | Banet et al. |
| 2011/0196235 | A1 | 8/2011 | Dunbar et al. | 2014/0188133 | A1 | 7/2014 | Misener |
| 2011/0196248 | A1 | 8/2011 | Grunwald | 2014/0221862 | A1 | 8/2014 | Tambe |
| 2011/0196255 | A1 | 8/2011 | Kassab | 2014/0228689 | A1 | 8/2014 | Ishikawa et al. |
| 2011/0237935 | A1 | 9/2011 | Kalpin et al. | 2014/0243659 | A1 | 8/2014 | Rothenberg |
| 2011/0245659 | A1 | 10/2011 | Ma et al. | 2014/0249428 | A1 | 9/2014 | Ingold, Jr. et al. |
| 2011/0282187 | A1 | 11/2011 | Harlev et al. | 2014/0249505 | A1 | 9/2014 | Bukhman |
| 2011/0282188 | A1 | 11/2011 | Burnside et al. | 2014/0253270 | A1 | 9/2014 | Nicholls et al. |
| 2011/0282285 | A1 | 11/2011 | Blanchard et al. | 2014/0257080 | A1 | 9/2014 | Dunbar et al. |
| 2011/0282686 | A1 | 11/2011 | Venon et al. | 2014/0275957 | A1 | 9/2014 | Lupotti |
| 2011/0295108 | A1 | 12/2011 | Cox et al. | 2014/0275990 | A1 | 9/2014 | Hagy et al. |
| 2011/0306859 | A1 | 12/2011 | Saldivar et al. | 2014/0276010 | A1 | 9/2014 | Anderson |
| 2011/0306867 | A1 | 12/2011 | Gopinathan et al. | 2014/0303492 | A1 | 10/2014 | Burnside et al. |
| 2011/0313293 | A1 | 12/2011 | Lindekugel et al. | 2014/0309624 | A1 | 10/2014 | Bown et al. |
| 2012/0004564 | A1 | 1/2012 | Dobak, III | 2014/0343398 | A1 | 11/2014 | He et al. |
| 2012/0035460 | A1 | 2/2012 | Stangenes et al. | 2015/0005621 | A1 | 1/2015 | Liu |
| 2012/0046562 | A1 | 2/2012 | Powers et al. | 2015/0018701 | A1 | 1/2015 | Cox et al. |
| 2012/0059249 | A1 | 3/2012 | Verard et al. | 2015/0025365 | A1 | 1/2015 | Esguerra Wilczynski et al. |
| 2012/0059270 | A1 | 3/2012 | Grunwald | 2015/0025402 | A1 | 1/2015 | Rothenberg |
| 2012/0059271 | A1 | 3/2012 | Amitai et al. | 2015/0051489 | A1 | 2/2015 | Caluser et al. |
| 2012/0071751 | A1 | 3/2012 | Sra et al. | 2015/0073285 | A1 | 3/2015 | Albert et al. |
| 2012/0071759 | A1 | 3/2012 | Hagy et al. | 2015/0080716 | A1 | 3/2015 | Powers et al. |
| 2012/0071782 | A1 | 3/2012 | Patil et al. | 2015/0209008 | A1 | 7/2015 | Ridley et al. |
| 2012/0078342 | A1 | 3/2012 | Vollkron et al. | 2015/0216445 | A1 | 8/2015 | Carmeli et al. |
| 2012/0095319 | A1 | 4/2012 | Kondrosky et al. | 2015/0216446 | A1 | 8/2015 | Bukhman et al. |
| 2012/0108950 | A1 | 5/2012 | He et al. | 2015/0223775 | A1 | 8/2015 | Hamilton, Jr. |
| 2012/0143029 | A1 | 6/2012 | Silverstein et al. | 2015/0245809 | A1 | 9/2015 | Nagy et al. |
| 2012/0143078 | A1 | 6/2012 | Kassab et al. | 2015/0245872 | A1 | 9/2015 | Nagy et al. |
| 2012/0172727 | A1 | 7/2012 | Hastings et al. | 2015/0246247 | A1 | 9/2015 | Binnekamp et al. |
| 2012/0220854 | A1 | 8/2012 | Messerly et al. | 2015/0282734 | A1 | 10/2015 | Schweikert et al. |
| 2012/0265084 | A1 | 10/2012 | Stewart et al. | 2015/0289781 | A1 | 10/2015 | Grunwald et al. |
| 2012/0283582 | A1 | 11/2012 | Mahapatra et al. | 2015/0297114 | A1 | 10/2015 | Cox et al. |
| 2012/0296200 | A1 | 11/2012 | Shachar et al. | 2015/0317810 | A1 | 11/2015 | Grunwald et al. |
| 2012/0310052 | A1 | 12/2012 | Mahapatra et al. | 2015/0335310 | A1 | 11/2015 | Bernstein et al. |
| 2012/0310066 | A1 | 12/2012 | Shachar et al. | 2015/0335383 | A9 | 11/2015 | Cohen |
| 2012/0310660 | A1 | 12/2012 | Liu et al. | 2016/0067449 | A1 | 3/2016 | Misener et al. |
| 2012/0316440 | A1 | 12/2012 | Munrow et al. | 2016/0278869 | A1 | 9/2016 | Grunwald |
| 2013/0006100 | A1 | 1/2013 | Shachar et al. | 2017/0000367 | A1 | 1/2017 | Grunwald |
| 2013/0006102 | A1 | 1/2013 | Wilkes et al. | 2017/0020561 | A1 | 1/2017 | Cox et al. |
| 2013/0018248 | A1 | 1/2013 | Hurezan | 2017/0079548 | A1 | 3/2017 | Silverstein et al. |
| 2013/0035590 | A1 | 2/2013 | Ma et al. | 2017/0079552 | A1 | 3/2017 | Grunwald |
| 2013/0041254 | A1 | 2/2013 | Nagy et al. | 2017/0079615 | A1 | 3/2017 | Burnside et al. |
| 2013/0041269 | A1 | 2/2013 | Stahmann et al. | 2017/0079681 | A1 | 3/2017 | Burnside et al. |
| 2013/0060116 | A1 | 3/2013 | Messerly et al. | 2017/0086782 | A1 | 3/2017 | Nagy et al. |
| 2013/0079628 | A1 | 3/2013 | Groszmann et al. | 2017/0151022 | A1 | 6/2017 | Jacob et al. |
| 2013/0085416 | A1 | 4/2013 | Mest | 2017/0215762 | A1 | 8/2017 | Burnside et al. |
| 2013/0090938 | A1 | 4/2013 | Fishman et al. | 2017/0231700 | A1 | 8/2017 | Cox et al. |
| 2013/0102890 | A1 | 4/2013 | Dib | 2017/0281029 | A1 | 10/2017 | Messerly et al. |
| 2013/0123597 | A1 | 5/2013 | Rothenberg | 2018/0070856 | A1 | 3/2018 | Grunwald |
| 2013/0131503 | A1 | 5/2013 | Schneider et al. | 2018/0103869 | A1 | 4/2018 | Bukhman et al. |
| 2013/0169272 | A1 | 7/2013 | Eichler et al. | 2018/0116551 | A1 | 5/2018 | Newman et al. |
| 2013/0217999 | A1 | 8/2013 | Burnside et al. | 2018/0169389 | A1 | 6/2018 | Lemon et al. |
| 2013/0245434 | A1 | 9/2013 | Messerly et al. | 2019/0069877 | A1 | 3/2019 | Burnside et al. |
| 2013/0281837 | A1 | 10/2013 | Ridley et al. | 2019/0099108 | A1 | 4/2019 | Messerly et al. |
| 2013/0289417 | A1 | 10/2013 | Grunwald et al. | | | | |
| 2013/0296691 | A1 | 11/2013 | Ashe | | | | |
| 2013/0296693 | A1 | 11/2013 | Wenzel et al. | | | | |
| 2013/0303878 | A1 | 11/2013 | Nevo et al. | | | | |

FOREIGN PATENT DOCUMENTS

- | | | |
|----|---------------|---------|
| AU | 20009592 | 9/2000 |
| AU | 20015250 | 6/2001 |
| AU | 768362 B2 | 12/2003 |
| AU | 2001229024 B2 | 9/2005 |
| AU | 2001283703 B2 | 5/2006 |

(56)

References Cited

FOREIGN PATENT DOCUMENTS

AU	2006202149	6/2006	JP	2006508744	A	3/2006
AU	2006904933	9/2006	JP	2006-338526	A	12/2006
AU	2006283022	B2 2/2012	JP	2007-000226	A	1/2007
CA	2420676	2/2002	JP	2007-068989	A	3/2007
CA	2619909	C 1/2014	JP	2007-105450	A	4/2007
CN	2031655	U 2/1989	JP	2007-313122	A	12/2007
CN	1672649	A 9/2005	JP	2009/271123	A	11/2009
CN	1913833	A 2/2007	JP	5010604		6/2012
CN	101854853	A 10/2010	JP	2012-529929		11/2012
CN	102209490	A 10/2011	JP	2013-518676	A	5/2013
CN	102802514	A 11/2012	JP	2013-526959	A	6/2013
CN	102821679	A 12/2012	JP	2013-526961	A	6/2013
CN	103037761	A 4/2013	RU	2009101949	A	7/2010
CN	103037762	A 4/2013	WO	1980002376	A1	11/1980
CN	103118591	A 5/2013	WO	1991012836	A1	9/1991
CN	103189009	A 7/2013	WO	1992003090		3/1992
DE	4319033	C1 6/1994	WO	1994003159	A1	2/1994
EP	0359697	3/1990	WO	1994004938		3/1994
EP	0362821	4/1990	WO	1996005768	A1	2/1996
EP	0399536	A1 11/1990	WO	1996007352	A1	3/1996
EP	0823261	A2 2/1998	WO	1996041119		12/1996
EP	0928976	A2 7/1999	WO	1997/22395	A1	6/1997
EP	1025805	A1 8/2000	WO	1997029683	A1	8/1997
EP	1015967	B1 4/2002	WO	1997043989	A1	11/1997
EP	1311226	A1 5/2003	WO	97/48438	A2	12/1997
EP	1504713	A1 2/2005	WO	1998025159	A1	6/1998
EP	1117331	B1 5/2005	WO	98/29032	A1	7/1998
EP	1117332	B1 8/2005	WO	1998035611	A1	8/1998
EP	1118019	B1 5/2006	WO	1999016495	A1	4/1999
EP	1717601	A2 11/2006	WO	1999027837	A2	6/1999
EP	1887940	A2 2/2008	WO	1999049407	A1	9/1999
EP	1932477	A1 6/2008	WO	2000019906		4/2000
EP	2337491	A1 6/2011	WO	2000027281	A1	5/2000
EP	2440122	A1 4/2012	WO	2000040155		7/2000
EP	2464407	A2 6/2012	WO	2000063658	A2	10/2000
EP	2482719	A1 8/2012	WO	2000074775	A1	12/2000
EP	2531098	A1 12/2012	WO	2001013792	A1	3/2001
EP	2575610	A1 4/2013	WO	2001039683	A1	6/2001
EP	2575611	A1 4/2013	WO	2001076479	A1	10/2001
EP	2603145	A2 6/2013	WO	02/07794	A2	1/2002
EP	2605699	A2 6/2013	WO	2002015973	A1	2/2002
EP	2474268	B1 7/2013	WO	2002019905	A1	3/2002
EP	2618727	A1 7/2013	WO	2002025277	A1	3/2002
EP	2632360	A1 9/2013	WO	2002085442	A1	10/2002
EP	2219526	B1 3/2014	WO	2003061752		7/2003
EP	2712547	A1 4/2014	WO	2003077759	A1	9/2003
EP	2313143	B1 9/2014	WO	03/088833	A1	10/2003
EP	2992825	B1 5/2017	WO	2003091495	A1	11/2003
EP	2170162	B1 8/2017	WO	2004002303	A1	1/2004
EP	2265175	B1 8/2017	WO	2004049970	A2	6/2004
FR	2545349	11/1984	WO	2005033524	A1	4/2005
JP	01097440	4/1989	WO	2005033574	A1	4/2005
JP	03173542	A 7/1991	WO	2005/089851	A1	9/2005
JP	4090741	8/1992	WO	2005117690	A1	12/2005
JP	9-503054	3/1997	WO	2005117733	A2	12/2005
JP	09-094298	A 4/1997	WO	2006074509	A1	7/2006
JP	10043310	2/1998	WO	2006074510	A1	7/2006
JP	10290839	A 11/1998	WO	2006078677	A2	7/2006
JP	11128237	A 5/1999	WO	2006103661	A2	10/2006
JP	2001-145630	A 5/2001	WO	2006111056	A1	10/2006
JP	2001161683	6/2001	WO	2007002541	A2	1/2007
JP	2001-514533	A 9/2001	WO	2007005976	A1	1/2007
JP	2001-524339	A 12/2001	WO	2007014447	A1	2/2007
JP	2001340334	12/2001	WO	2007034196	A2	3/2007
JP	2002-224069	A 8/2002	WO	2007067324	A1	6/2007
JP	2002-529133	A 9/2002	WO	2007069168	A2	6/2007
JP	2002-541947	A 12/2002	WO	2007109123	A2	9/2007
JP	2003-010138	A 1/2003	WO	2007126536	A2	11/2007
JP	2003501127	A 1/2003	WO	2007144894	A1	12/2007
JP	2003061752	A 3/2003	WO	2008005480	A1	1/2008
JP	2003299654	10/2003	WO	2008024596	A2	2/2008
JP	2003334191	11/2003	WO	2008028253		3/2008
JP	2002520893	2/2004	WO	2008083111		7/2008
JP	2004505748	T 2/2004	WO	2008097767	A2	8/2008
JP	2004515298	A 5/2004	WO	2008118992	A1	10/2008
			WO	2008126074	A2	10/2008
			WO	2008129326	A1	10/2008
			WO	2008131017	A2	10/2008
			WO	2008136008	A2	11/2008

(56)

References Cited

FOREIGN PATENT DOCUMENTS

WO	2009000439	A1	12/2008
WO	2009002514	A2	12/2008
WO	2009003138	A1	12/2008
WO	2009009064	A1	1/2009
WO	2009057774	A1	5/2009
WO	2009063166	A1	5/2009
WO	2009067654	A1	5/2009
WO	2009070616	A2	6/2009
WO	2009100158	A1	8/2009
WO	2009123819	A2	10/2009
WO	2009126340	A1	10/2009
WO	2009129475	A1	10/2009
WO	2009129477	A1	10/2009
WO	2009134605	A2	11/2009
WO	2009137262	A2	11/2009
WO	2010002313	A1	1/2010
WO	2010018500	A1	2/2010
WO	2010022370	A1	2/2010
WO	2010027349	A1	3/2010
WO	2010027471	A2	3/2010
WO	2010029906	A1	3/2010
WO	2010030820	A1	3/2010
WO	2010132857	A1	11/2010
WO	2010132985	A1	11/2010
WO	2010/144922	A1	12/2010
WO	2010143196	A1	12/2010
WO	2011019760	A2	2/2011
WO	2011041450	A1	4/2011
WO	2011044421	A1	4/2011
WO	2011057289	A2	5/2011
WO	2011064209	A1	6/2011
WO	2011084593	A2	7/2011
WO	2011097312	A1	8/2011
WO	2011128052	A2	10/2011
WO	2011150358	A1	12/2011
WO	2011150376	A1	12/2011
WO	2012021542	A2	2/2012
WO	2012024577	A2	2/2012
WO	2012039866	A1	3/2012
WO	2012040487	A1	3/2012
WO	2012058461	A1	5/2012
WO	2012083245	A1	6/2012
WO	2012088535	A1	6/2012
WO	2012110955	A1	8/2012
WO	2012173697	A1	12/2012
WO	2013006713	A2	1/2013
WO	2013006817	A1	1/2013
WO	2013034175	A1	3/2013
WO	2014042329	A1	3/2014
WO	2014052894	A2	4/2014
WO	2014062728	A1	4/2014
WO	2014138652	A1	9/2014
WO	2014138918	A1	9/2014
WO	2015/055797	A1	4/2015
WO	2015048514	A1	4/2015
WO	2015073962	A1	5/2015
WO	2015/120256	A2	8/2015
WO	2016/210325	A1	12/2016
WO	2018/112252	A1	6/2018

OTHER PUBLICATIONS

U.S. Appl. No. 14/309,511, filed Jun. 19, 2014 Notice of Allowance, dated Jul. 26, 2016.
 U.S. Appl. No. 14/317,501, filed Jun. 27, 2014 Advisory Action dated Sep. 16, 2015.
 U.S. Appl. No. 14/317,501, filed Jun. 27, 2014 Examiner's Answer dated Jun. 30, 2016.
 U.S. Appl. No. 14/317,501, filed Jun. 27, 2014 Final Office Action dated Jul. 1, 2015.
 U.S. Appl. No. 14/317,501, filed Jun. 27, 2014 Non-Final Office Action dated Mar. 3, 2015.
 U.S. Appl. No. 14/317,501, filed Jun. 27, 2014 Non-Final Office Action dated Sep. 12, 2014.

U.S. Appl. No. 14/449,061, filed Jul. 31, 2014 Final Office Action dated Nov. 6, 2015.

U.S. Appl. No. 14/449,061, filed Jul. 31, 2014 Non-Final Office Action dated Apr. 27, 2015.

U.S. Appl. No. 14/449,061, filed Jul. 31, 2014 Notice of Allowance dated Apr. 13, 2016.

U.S. Appl. No. 14/498,887, filed Sep. 26, 2014 Advisory Action dated Aug. 22, 2016.

U.S. Appl. No. 14/498,887, filed Sep. 26, 2014 Final Office Action dated Jun. 15, 2016.

U.S. Appl. No. 14/498,887, filed Sep. 26, 2014 Non-Final Office Action dated Feb. 19, 2016.

U.S. Appl. No. 14/506,552, filed Oct. 3, 2014 Non-Final Office Action dated Oct. 1, 2015.

U.S. Appl. No. 14/548,151, filed Nov. 19, 2014 Advisory Action dated Jul. 22, 2016.

U.S. Appl. No. 14/548,151, filed Nov. 19, 2014 Non-Final Office Action dated Jun. 5, 2015.

U.S. Appl. No. 29/428,649, filed Aug. 1, 2012 Notice of Allowance dated Jul. 5, 2013.

Valdivieso, J.R. Perez, et al., Evaluation of a formula for optimal positioning of a central venous catheter inserted through the right internal jugular vein, *Rev. Esp. Anestesiol. Reanim.* 2003; 50: 77-79.

VasoNova Inc, Vascular navigation system for accurate placement of PICCs, *Start-Up Emerging Medical Ventures*, pp. 44-45, vol. 14 No. 7, Jul.-Aug. 2009.

Vesely, Thomas M. et al., Central Venous Catheter Tip Position: A Continuing Controversy, *J Vasc Interv Radiol* 2003; 14:527-534.

VIASYS Health Care Inc. Cortrak © Fact Sheet, 2005.

VIASYS Healthcare MedSystems, Navigator® Benefits, 2008.

VIASYS Healthcare MedSystems, Navigator® Research in Cost Justification, 2008.

VIASYS MedSystems, Cortrak™ Systems Brochure, 2005.

Volcano ComboMap Features and Benefits/Technical Specifications, 2 pages, 2011.

Watters, et al. "Use of Electrocardiogram to Position Right Atrial Catheters During Surgery." *Annals of Surgery*, vol. 225, No. 2, pp. 165-171, 1997.

Welch Allyn Cardioperfect® PC-Based Resting ECG, 2003.

Wilson, R. G. et al, Right Atrial Electrocardiography in Placement of Central Venous Catheters, *The Lancet*, pp. 462-463, Feb. 27, 1988.

Wong, Jeffrey J. et al., Azygos Tip Placement for Hemodialysis Catheters in Patients with Superior Vena Cava Occlusion, *Cardiovasc Intervent Radiol* (2006) 29:143-146.

Worley, Seth J. "Use of a Real-Time Three-Dimensional Magnetic Navigation System for Radiofrequency Ablation of Accessory Pathways." *PACE*, vol. 21 pp. 1636-1643, Aug. 1998.

Yilmazlar A et al, Complications of 1303 Central Venous Cannulations, *J R Soc Med*, pp. 319-321, vol. 90 No. 6, Jun. 1997 (Abstract only).

Yoon, SZ et al, Usefulness of the Carina as a Radiographic Landmark for Central Venous Catheter Placement in Paediatric Patients, *Br J Anaesth*, Jul. 2005.

Yoshida, Teruhisa et al, Detection of Concealed Left Sided Accessory Atrioventricular Pathway by P Wave Signal Averaged Electrocardiogram, *J Am Coll Cardiol*, pp. 55-62, 1999.

Zaaroor, et al. "Novel Magnetic Technology for Intraoperative Intracranial Frameless Navigation: In Vivo and in Vitro Results." *Neurosurgery*, vol. 48, No. 5. pp. 1100-1107, May 2001.

Zachariou, Zacharias et al., Intra-atrial ECG recording: a new and safe method for implantation of Broviac catheters in children, *Pediatr Surg Int* (1994) 9: 457-458.

Zaidi, Naveed A., et al. "Room temperature magnetic order in an organic magnet derived from polyaniline." 2004, *Polymer*, vol. 45, pp. 5683-5689.

U.S. Appl. No. 13/240,171, filed Sep. 22, 2011 Advisory Action dated Jul. 22, 2016.

U.S. Appl. No. 13/240,171, filed Sep. 22, 2011 Final Office Action dated Jun. 10, 2015.

U.S. Appl. No. 13/240,171, filed Sep. 22, 2011 Final Office Action dated May 6, 2016.

(56)

References Cited

OTHER PUBLICATIONS

- U.S. Appl. No. 13/240,171, filed Sep. 22, 2011 Non-Final Office Action dated Dec. 1, 2015.
- U.S. Appl. No. 13/240,171, filed Sep. 22, 2011 Non-Final Office Action dated Dec. 26, 2014.
- U.S. Appl. No. 13/283,395, filed Oct. 27, 2011 Advisory Action dated Jan. 28, 2014.
- U.S. Appl. No. 13/283,395, filed Oct. 27, 2011 Final Office Action dated Nov. 14, 2011.
- U.S. Appl. No. 13/283,395, filed Oct. 27, 2011 Non-Final Office Action dated Apr. 23, 2013.
- U.S. Appl. No. 13/336,919, filed Dec. 23, 2011 Advisory Action dated May 23, 2013.
- U.S. Appl. No. 13/336,919, filed Dec. 23, 2011 Final Office Action dated Dec. 19, 2014.
- U.S. Appl. No. 13/336,919, filed Dec. 23, 2011 Final Office Action dated Mar. 1, 2013.
- U.S. Appl. No. 13/336,919, filed Dec. 23, 2011 Non-Final Office Action dated Dec. 27, 2011.
- U.S. Appl. No. 13/336,919, filed Dec. 23, 2011 Non-Final Office Action dated Jul. 9, 2015.
- U.S. Appl. No. 13/336,919, filed Dec. 23, 2011 Non-Final Office Action dated Oct. 16, 2012.
- U.S. Appl. No. 13/336,919, filed Dec. 23, 2011 Notice of Allowance dated Jul. 26, 2016.
- U.S. Appl. No. 13/337,987, filed Dec. 27, 2011 Examiner's Answer dated Jul. 2, 2014.
- U.S. Appl. No. 13/337,987, filed Dec. 27, 2011 Final Office Action dated Sep. 19, 2013.
- U.S. Appl. No. 13/337,987, filed Dec. 27, 2011 Non-Final Office Action dated Mar. 15, 2013.
- U.S. Appl. No. 13/469,932, filed May 11, 2012 Advisory Action dated Jun. 27, 2016.
- U.S. Appl. No. 13/469,932, filed May 11, 2012 Non-Final Office Action dated Jan. 3, 2014.
- U.S. Appl. No. 13/469,932, filed May 11, 2012 Non-Final Office Action dated Jul. 31, 2014.
- U.S. Appl. No. 13/469,932, filed May 11, 2012 Non-Final Office Action dated Sep. 4, 2015.
- U.S. Appl. No. 13/469,932, filed May 11, 2012 Final Office Action dated Apr. 7, 2016.
- U.S. Appl. No. 13/665,420, filed Oct. 31, 2012 Final Office Action dated Apr. 8, 2016.
- U.S. Appl. No. 13/665,420, filed Oct. 31, 2012 Non-Final Office Action dated Jan. 6, 2014.
- U.S. Appl. No. 13/665,420, filed Oct. 31, 2012 Non-Final Office Action dated Jul. 9, 2015.
- U.S. Appl. No. 13/665,420, filed Oct. 31, 2012 Non-Final Office Action dated Oct. 9, 2014.
- U.S. Appl. No. 13/737,806, filed Jan. 9, 2013 Notice of Allowance dated Oct. 31, 2013.
- U.S. Appl. No. 13/858,782, filed Apr. 8, 2013 Notice of Allowance dated Oct. 9, 2014.
- U.S. Appl. No. 13/887,166, filed May 3, 2013 Advisory Action dated Aug. 27, 2014.
- U.S. Appl. No. 13/887,166, filed May 3, 2013 Examiner's Answer dated Jul. 16, 2015.
- U.S. Appl. No. 13/887,166, filed May 3, 2013 Final Office Action dated Jun. 23, 2014.
- U.S. Appl. No. 13/887,166, filed May 3, 2013 Non-Final Office Action dated Jan. 7, 2014.
- U.S. Appl. No. 13/890,158, filed May 8, 2013 Advisory Action dated Jul. 26, 2016.
- U.S. Appl. No. 13/890,158, filed May 8, 2013 Non-Final Office Action dated Aug. 15, 2014.
- U.S. Appl. No. 13/890,158, filed May 8, 2013 Non-Final Office Action dated Jul. 9, 2015.
- U.S. Appl. No. 13/969,265, filed Aug. 16, 2013 Non-Final Office Action dated Dec. 19, 2013.
- U.S. Appl. No. 13/969,265, filed Aug. 16, 2013 Notice of Allowance dated Jun. 23, 2014.
- U.S. Appl. No. 14/040,205, filed Sep. 27, 2013 Non-Final Office Action dated Mar. 10, 2016.
- U.S. Appl. No. 14/141,046, filed Dec. 26, 2013 Advisory Action dated Aug. 4, 2016.
- U.S. Appl. No. 14/141,046, filed Dec. 26, 2013 Final Office Action dated May 11, 2016.
- U.S. Appl. No. 14/141,046, filed Dec. 26, 2013 Non-Final Office Action dated Feb. 11, 2015.
- U.S. Appl. No. 14/141,046, filed Dec. 26, 2013 Non-Final Office Action dated Jun. 20, 2014.
- U.S. Appl. No. 14/141,046, filed Dec. 26, 2013 Non-Final Office Action dated Nov. 5, 2015.
- U.S. Appl. No. 14/201,300, filed Mar. 7, 2014 Advisory Action dated Jul. 18, 2016.
- U.S. Appl. No. 14/201,300, filed Mar. 7, 2014 Final Office Action dated May 5, 2016.
- U.S. Appl. No. 14/201,300, filed Mar. 7, 2014 Non-Final Office Action dated Aug. 24, 2016.
- U.S. Appl. No. 14/201,300, filed Mar. 7, 2014 Non-Final Office Action dated Jan. 6, 2016.
- U.S. Appl. No. 14/270,241, filed May 5, 2014 Non-Final Office Action dated Apr. 23, 2015.
- U.S. Appl. No. 14/270,241, filed May 5, 2014 Notice of Allowance dated Oct. 7, 2015.
- Gebhard, et al., "The accuracy of Electrocardiogram-Controlled Central Line Placement." *The International Anesthesia Research Society*, vol. 104, No. 1 Jan. 2007.
- Gjendemsjo, Anders, et al., *Energy and Power, The Connexions Project*, Version 1.2, Feb. 20, 2004.
- Gladwin, MT et al, *Cannulation of the Internal Jugular Vein: is postprocedural chest radiography always necessary?*, *Crit Care Med*, 33 pages, Oct. 2000.
- Gonzales, et al. "Peripherally Inserted Central Catheter Placement in Swine Using Magnet Detection." *Journal of Intravenous Nursing*, vol. 22, No. 3, May/June. 1999.
- Greenall, M.J. et al, *Cardiac Tamponade and Central Venous Catheters*, *British Medical Journal*, pp. 595-597, Jun. 14, 1975.
- Guillory, "Basic Principles of Technologies for Catheter Localization." C.R. Bard internal paper, Oct. 20, 2004.
- Guth, AA, *Routine Chest X-rays after Insertion of Implantable Long-Term Venous Catheters: Necessary or Not?*, *Am Surg*, pp. 26-29, vol. 67 No. 1, Jan. 2001 (Abstract only).
- Hill, Bradley et al, *Abstract of article discussing VasaNova VPS as guide for placement of PICCs*. 2009.
- Hill, Bradley, *Identifying the Caval-Atrial Junction Using Smart-Catheter Technology presentation*, 22nd Annual Scientific Meeting of the AVA in Savannah, Georgia, Sep. 13, 2008.
- Hoffman, Thomas et al, *Simultaneous Measurement of Pulmonary Venous Flow by Intravascular Catheter Doppler Velocimetry and Transesophageal Doppler Echocardiography: Relation to Left Atrial Pressure and Left Atrial and Left Ventricular Function*, pp. 239-249, *J Am Coll Cardiol*, Jul. 1995.
- Hoffmann, et al. "New Procedure in Transesophageal Echocardiography: Multiplane Transesophageal Echocardiography and Transesophageal Stress Echocardiography." *Herz*, vol. 18, No. 5, pp. 269-277, Oct. 1993.
- Iacopino, Domenico Gerardo et al, *Intraoperative Microvascular Doppler Monitoring of Blood Flow within a Spinal Dural Arteriovenous Fistula: A Precious Surgical Tool*, vol. 10, 5 pages, *Neurosurg. Focus*, Feb. 2001.
- Jeon, Yunseok et al., "Transesophageal Echocardiographic Evaluation of ECG-guided Central Venous Catheter Placement," *Canadian Journal of Anesthesia*, vol. 53, No. 10, Oct. 1, 2006, pp. 978-983.
- Joosting, Jean-Pierre, "Dual-interface RFID-compatible EEPROM enables remote access to electronic device parameters," *EE Times*, Mar. 8, 2010.
- JP 2008-528151 filed Aug 24, 2006 Notice of Grant dated May 6, 2012.
- JP 2010-504220 filed Sep. 3, 2009 Final Office Action dated Apr. 18, 2013.

(56)

References Cited

OTHER PUBLICATIONS

- JP 2010-504220 filed Sep. 3, 2009 Office Action dated Apr. 1, 2014.
 JP 2010-504220 filed Sep. 3, 2009 Office Action dated Apr. 18, 2013.
 JP 2010-504220 filed Sep. 3, 2009 Office Action dated May 21, 2012.
 JP 2010-535117 filed May 26, 2011 First Office Action dated Aug. 5, 2013.
 JP 2012-515222 filed Dec. 9, 2011 Office Action dated Feb. 23, 2015.
 JP 2012-515222 filed Dec. 9, 2011 Office Action dated Mar. 24, 2014.
 JP 2012-552060 filed Aug. 1, 2012 Office Action dated Nov. 12, 2014.
 JP 2012-552060 filed Aug. 1, 2012 Second Office Action dated Nov. 6, 2015.
 JP 2013-512046 filed Nov. 26, 2012 First Office Action dated Mar. 23, 2015.
 JP 2013-512046 filed Nov. 26, 2012 Office Action dated Dec. 8, 2015.
 JP 2013-512046 filed Nov. 26, 2012 Office Action dated May 16, 2016.
 JP 2013-512051 filed Nov. 26, 2012 First Office Action dated Mar. 23, 2015.
 JP 2013-524999 filed Jan. 22, 2013 First Office Action dated Jun. 1, 2015.
 JP 2014-519081 filed Dec. 27, 2013 First Office Action dated Apr. 26, 2016.
 JP2013-530322 filed Mar. 18, 2013, Office Action dated May 2, 2016.
 JP2013-530322 filed Mar. 18, 2013, First Office Action dated Jul. 31, 2015.
 Kim, Ko et al, Positioning Internal Jugular Venous Catheters using the Right Third Intercostal Space in Children, *Acta Anaesthesiol Scand*, pp. 1284-1286, vol. 47 No. 10, Nov. 2003.
 Kjelstrup T et al, Positioning of Central Venous Catheters using ECG, *Tidsskr nor Laegeforen*, pp. 599-601, vol. 111 No. 5, Feb. 1999 (Abstract only).
 Kofler, Julia, et al., Epinephrine application via an endotracheal airway and via the Combitube in esophageal position, *Critical Care Medicine*: May 2000, vol. 28: Issue 5, pp. 1445-1449.
 Konings, MK, et al., Development of an intravascular impedance catheter for detection of fatty lesions in arteries, *IEEE Trans Med Imaging* Aug. 1997; 16(4):439-46.
 Kowalski, CM et al, Migration of Central Venous Catheters: Implications for Initial Catheter Tip Positioning, *J Vasc Interv Radiol*, pp. 443-447, vol. 8 No. 3, May-Jun. 1997.
 KR 10-2012-7000866 filed Jan. 11, 2012 First Office Action dated Jun. 16, 2016.
 Leowenthal, MR et al, The Peripherally Inserted Central Catheter (PICC): A Prospective Study of its Natural History after Fossa Insertion, *Anaesth Intensive Care*, pp. 21-24; vol. 30 No. 1, Feb. 2002.
 Lepage Ronan et al. ECG Segmentation and P-wave Feature Extraction: Application to Patients Prone to Atrial Fibrillation, *IEEE/EMBS Proceedings, 23rd Annual Conference, Istanbul, Turkey*, Oct. 25-28, 2001.
 Liu , Ji-Bin et al, Catheter-Based Intraluminal Sonography, *J Ultrasound Med*, pp. 145-160, vol. 23, 2004.
 Lucey, B et al, Routine Chest Radiographs after Central Line Insertion: Mandatory Postprocedural Evaluation or Unnecessary Waste of Resources?, *Cardiovasc Intervent Radiol*, pp. 381-384, vol. 22 No. 5, Sep.-Oct. 1999.
 Lum, Phillip, A New Formula-Based Measurement Guide for Optimal Positioning of Central Venous Catheters, *JAVA*, vol. 9, No. 2, pp. 80-85, 2004.
 Lynch, RE et al, A Procedure for Placing Pediatric Femoral Venous Catheter Tips near the Right Atrium, *Pediatr Emerg Care*, pp. 130-132, vol. 18 No. 2, Apr. 2002.
 Madan, et al. "Right Atrial Electrocardiography: A Technique for the Placement of Central Venous Catheters for Chemotherapy or Intravenous Nutrition." *British Journal of Surgery*, vol. B1, pp. 1604-1605, 1994.
 Madias, John E, Intracardiac (Superior Vena Cava/Right Atrial) ECGs using Saline Solution as the Conductive Medium for the Proper Positioning of the Shiley Hemodialysis Catheter: Is it Not Time to Forego the Postinsertion Chest Radiograph?, pp. 2363-2367, *CHEST*, 2003.
 Markovich, Mary B., Central Venous Catheter Tip Placement: Determination of Posterior Malposition—A Case Study, *JAVA*, vol. 11, No. 2, pp. 85-89, 2006.
 Martin, Roy W, An Ultrasound Catheter for Intravascular Measurement of Blood Flow: Technical Details, *IEEE Transactions on Sonics and Ultrasonics*, vol. SU-27, No. 6, pp. 277-286, Nov. 1980.
 McDonnall, "Intra-Atrial Electrocardiography (ECG) for Catheter Placement." Literature review prepared for Bard Access Systems, Oct. 2007.
 McGee et al., "Accurate Placement of Central Venous Catheters: A Prospective, Randomize, Multicenter Trial." *Critical Care Medicine*, vol. 21 No. 8, Aug. 1993.
 MedGraphics, CardioPerfect® Resting/Stress ECG System, 3 pages, 2001.
 Michenfelder, John et al, Air Embolism During Neurosurgery—An Evaluation of Right-Atrial Catheters for Diagnosis and Treatment, *JAMA*, pp. 1353-1358, vol. 208, No. 8, May 26, 1969.
 Michenfelder, John et al, Air Embolism During Neurosurgery. A New Method of Treatment, *Anesthesia and Analgesia. Current Researches*, pp. 390-395, vol. 45, No. 4, Jul.-Aug. 1966.
 MICROBIRD™ Miniaturized DC Magnetic Sensors for Intra-body Navigation and Localization, Specifications, 2005.
 Micronix CathRite™ Cardiac Access Device Brochure. Jun. 2004.
 Micronix Pty Ltd "CathRite" Guiding Styled Core Manufacturing, Jun. 15, 2006.
 Moureau, Nancy L. et al., "Electrocardiogram (EKG) Guided Peripherally Inserted Central Catheter Placement and Tip Position: Results of a Trial to Replace Radiological Confirmation," *Journal of the Association for Vascular Access*, pp. 8-14, vol. 15, No. 1, 2010.
 Murthy, Vrudhula et al, Analysis of Power Spectral Densities of Electrocardiograms, *Mathematical Biosciences*, pp. 41-51, vol. 12 No. 1-2, Oct. 1971.
 MX/a/2012/013672 filed Nov. 23, 2012 First Office Action dated Aug. 10, 2015.
 MX/a/2012/013858 filed Nov. 28, 2012 First Office Action dated Sep. 26, 2014.
 MX/a/2012/013858 filed Nov. 28, 2012 Second Office Action dated Jun. 10, 2015.
 MX/a/2013/001317 filed Jan. 31, 2013 First Office Action dated Nov. 26, 2015.
 Nadroo, AM et al, Changes in Upper Extremity Position Cause Migration of Peripherally Inserted Central Catheters in Neonates, *Pediatrics*, pp. 131-136, vol. 110, Jul. 2002.
 Nakatani, K et al, Accurate Placement of Central Venous Catheters—ECG-guided method vs Patient Height Method, *Masui*, pp. 34-38, vol. 51 No. 1, Jan. 2002.
 Nazarian, GK et al, Changes in Tunneled Catheter Tip Position when a patient is Upright, *J Vasc Interv Radiol*, pp. 437-441, vol. 8 No. 3, May-Jun. 1997.
 Neurometer® CPT, Clinical Applications. Neurotron , Inc. website: www.neurotron.com/CLINAPS.html, last accessed Oct. 23, 2006.
 Neurometer® CPT, Frequently Asked Questions. Neurotron , Inc. website: www.neurotron.com/CPTFAQ/html, last accessed Oct. 23, 2006.
 Neurometer® CPT, Products Page. Neurotron , Inc. website: www.neurotron.com/products.html, last accessed Oct. 23, 2006.
 Neurometer® Electrodiagnostic Neuroselective Sensory Nerve Evaluation: Charts, Tables, Documents & Downloads. Neurotron , Inc. website: www.neurotron.com/downloads.html, last accessed Oct. 23, 2006.
 Odd, De et al, Does Radio-opaque Contrast Improve Radiographic localisation of Percutaneous Central Venous Lines?, *Arch Dis Child Fetal Neonatal Ed*, pp. 41-43, vol. 89 No. 1, Jan. 2004.

(56)

References Cited

OTHER PUBLICATIONS

Palesty, JA et al, Routine Chest Radiographs Following Central Venous Recatheterization over a Wire are not Justified, *Am J Surg*, pp. 618-621, vol. 176 No. 6, Dec. 1998.

Paliotti, Roberta P. et al, Intravascular Doppler Technique for Monitoring Renal Venous Blood Flow in Man, *J Nephrol*, pp. 57-62, 2003.

Parker, K.H. et al, Cardiovascular Fluid Dynamics, Department of Bioengineering, National Heart and Lung Institute, Imperial College of Science, Technology and Medicine, Cardiovascular Haemodynamics, pp. 1-28, Sep. 26, 2005.

Pawlik, et al., "Central Venous Catheter Placement: Comparison of the Intravascular Guidewire and the Fluid Column Electrocardiograms." *European Journal of Anaesthesiology*, vol. 41, pp. 594-599, 2004.

PCT/US13/62409 filed Sep. 27, 2013 International Search Report and Written Opinion dated Feb. 24, 2014.

PCT/US2006/033079 filed Aug. 24, 2006 International Preliminary Report on Patentability dated Feb. 26, 2008.

PCT/US2006/033079 filed Aug. 24, 2006 Search Report dated Dec. 19, 2006.

PCT/US2006/033079 filed Aug. 24, 2006 Written Opinion dated Dec. 19, 2006.

PCT/US2008/060502 filed Apr. 16, 2008 International Search Report and Written Opinion dated Oct. 16, 2008.

PCT/US2008/084751 filed Nov. 25, 2008 International Preliminary Report on Patentability dated Jun. 1, 2010.

PCT/US2008/084751 filed Nov. 25, 2008 Search Report dated May 20, 2009.

PCT/US2008/084751 filed Nov. 25, 2008 Written Opinion dated May 20, 2009.

PCT/US2009/033116 filed Feb. 4, 2009 International Preliminary Report on Patentability dated Aug. 10, 2010.

PCT/US2009/033116 filed Feb. 4, 2009 Search Report dated Mar. 13, 2009.

PCT/US2009/033116 filed Feb. 4, 2009 Written Opinion dated Mar. 13, 2009.

PCT/US2009/041051 filed Apr. 17, 2009 International Preliminary Report on Patentability dated Apr. 8, 2014.

PCT/US2009/041051 filed Apr. 17, 2009 Search Report dated Jul. 28, 2009.

PCT/US2009/041051 filed Apr. 17, 2009 Written Opinion dated Jul. 28, 2009.

PCT/US2009/054687 filed Aug. 21, 2009 International Preliminary Report on Patentability dated Feb. 22, 2011.

PCT/US2009/054687 filed Aug. 21, 2009 Search Report dated Oct. 6, 2009.

PCT/US2009/054687 filed Aug. 21, 2009 Written Opinion dated Oct. 6, 2009.

PCT/US2009/056567 filed Sep. 10, 2009 International Preliminary Report on Patentability dated Mar. 15, 2011.

PCT/US2009/056567 filed Sep. 10, 2009 Search Report dated Nov. 6, 2009.

PCT/US2009/056567 filed Sep. 10, 2009 Written Opinion dated Nov. 6, 2009.

PCT/US2010/038555 filed Jun. 14, 2010 Search Report dated Oct. 5, 2010.

PCT/US2010/038555 filed Jun. 14, 2010 Written Opinion dated Oct. 5, 2010.

PCT/US2010/045084 filed Aug. 10, 2010 International Preliminary Report on Patentability dated Feb. 23, 2012.

PCT/US2010/045084 filed Aug. 10, 2010 Search Report dated Apr. 14, 2011.

PCT/US2010/045084 filed Aug. 10, 2010 Written Opinion dated Apr. 14, 2011.

PCT/US2010/050773 filed Sep. 29, 2010 Search Report dated Jan. 24, 2011.

"Ascension to Launch New 3D Guidance™ Tracker at TCT 2006." Press Releases from Ascension website: www.ascension-tech.com/news/press_101106.php, last accessed Dec. 1, 2006.

Acuson—The Value of Vision, AcuNav Diagnostic Ultrasound Catheter, 2000.

Advertising flyer for GAVECELT—The Italian Group for Long Term Venous Access Devices, for program on International Meeting on PICC's, Midline Catheters and Long Term Venous Access Devices in Catholic University, Rome, Italy on Dec. 3, 4, 5, 2008. Alexander, GD et al, The Role of Nitrous Oxide in Postoperative Nausea and Vomiting, Collection of Abstracts Presented at the International Anesthesia Research Society by various speakers, 58th Congress, Mar. 12-14, 1984, *Anesthesia and Analgesia*, pp. 175-284, vol. 63, 1984.

Allan, P.L. et al, Role of Ultrasound in the Assessment of Chronic Venous Insufficiency, *Ultrasound Quarterly*, vol. 17, No. 1, pp. 3-10, 2001.

Andropoulos, et al. "A Controlled Study of the Transesophageal Echocardiography to Guide Central Venous Catheter Placement in Congenital Heart Surgery Patients." *The International Anesthesia Research Society*, vol. 89, pp. 65-70, 1999.

Anonymous author, Correct Catheter Placement with a low-impact, reliable and economical method, <<http://www.cvc-partner.com/index.cfm?103A955CC6844BF58ACFE3C9C1471959>>, last accessed Dec. 22, 2011.

Arai, J et al, Detection of Peripherally Inserted Central Catheter Occlusion by in-line Pressure Monitoring, *Paediatr Anaesth*, pp. 621-624, vol. 12 No. 7, Sep. 2002.

Arrow International, Inc., The Arrow-Johans RAECG Adapter-Making Proper Central Venous Catheter Placement More Reliable (Modle No. EG-04900), Technical Report 1987, USA.

Aslamy, et al. "MRI of Central Venous Anatomy: Implications for Central Venous Catheter Insertion." *American College of Chest Physicians*, Jun. 8, 2009.

AU 2006283022 filed Aug. 24, 2006 Office Action dated Dec. 22, 2010.

AU 2008329807 exam requested Aug. 13, 2012 Examination Report No. 1 dated Feb. 15, 2013.

AU 2008329807 exam requested Aug. 13, 2012 Notice of Acceptance dated Feb. 14, 2014.

AU 2010300677 filed Mar. 12, 2012 First Examination Report dated Mar. 9, 2014.

AU 2011289513 filed Jan. 21, 2013 Examiner's Report dated Jul. 5, 2013.

AU 2012202293 filed Apr. 19, 2012 Examination Report No. 1 dated Apr. 24, 2013.

AU 2013201648 filed Mar. 19, 2013 Examiner's Report dated Mar. 5, 2014.

AU 2013201648 filed Mar. 19, 2013 Examiner's Report dated Oct. 14, 2013.

AU 2013202824 filed Apr. 6, 2013 First Examiner's Report dated Mar. 10, 2014.

AU 2013204243 filed Apr. 12, 2013 Examiner's Report dated Jun. 5, 2013.

AURORA® System Technical Specifications, Oct. 2003.

B. Braun Website, "The Optimal Position of the Central Venous Catheter." <http://www.cvcpartner.com/index.cfm?18F1BDEA1310466194960A39F4E90968> (2009).

B. Braun, Certofix Central Venous Catheter for Placement Using the Seldinger Technique with Simultaneous ECG Lead Option, Feb. 2010.

Bailey, SH et al, Is Immediate Chest Radiograph Necessary after Central Venous Catheter Placement in a Surgical Intensive Care Unit?, *Am J Surg*, pp. 517-522, vol. 180 No. 6, Dec. 2000.

Bankier, Alexander A., Azygos Arch Cannulation by Central Venous Catheters: Radiographic Detection of Malposition and Subsequent Complications, *Journal of Thoracic Imaging* 12:64-69 (1997).

Barber, JM et al, A Nurse led Peripherally Inserted Central Catheter Line Insertion Service is Effective with Radiological Support, *Clin Radiol*, pp. 352-354, vol. 57 No. 5, May 2002.

Bard Access Systems, Sherlock Tip Location System, 5 pages, 2006.

Bard Access Systems, Site Rite Vascular Access Ultrasound System, 4 pages, 2005.

(56)

References Cited

OTHER PUBLICATIONS

- Benchimol, Alberto et al, Right Atrium and Superior Vena Cava Flow Velocity in Man Measured with the Doppler-Catheter Flowmeter-Telemetry System, *The Amer Journal of Medicine*, pp. 303-309, vol. 48, Mar. 1970.
- Benzadon, M. N. et al: "Comparison of the Amplitude of the P-Wave from Intracardiac Electrocardiogram Obtained by Means of a Central Venous Catheter Filled With Saline Solution to That Obtained via Esophageal Electrocardiogram", *American Journal of Cardiology*, Canners Publishing Co., Newton, MA, US, vol. 98, No. 7, Oct. 1, 2006 (Oct. 1, 2006), pp. 978-981.
- BioAdvance Lumen Vu, Greenhouse Fund Feb. 2004 Recipient, www.bioadvance.com <<http://www.bioadvance.com>>, 2005.
- Borgobello, Bridget, App allows users to view electrocardiograms on smartphones dated Oct. 15, 2010; printed from <http://www.gizmag.com/app-to-view-electrocardiograms-on-smartphones/16664/> on Feb. 4, 2011.
- Buehrle, Douglas, PICC Placement in Humans using Electromagnetic Detection, <http://www.corpakmedsystems.com/supplement_material/supplementpages/navigator/navarticle.html>, 2008.
- C.R. Bard, CathTrack™ Catheter Location System at www.bardaccess.com <<http://www.bardaccess.com>>, last accessed Apr. 28, 2011.
- C.R. Bard, Inc., Bard Electrophysiology Product Catalogue, Bard Catheters, pp. 74-75 (2002), USA.
- CA 2,619,909 filed Aug. 24, 2006 Examiner's Report dated Oct. 26, 2012.
- CA 2,721,715 filed Apr. 17, 2009 Examiner's Report dated Aug. 18, 2015.
- Cadman, A et al, To Clot or Not to Clot? That is the question in Central Venous Catheters, *Clinical Radiology*, pp. 349-355, vol. 59 No. 4, Apr. 2004.
- Calvert, N et al, The Effectiveness and Cost-effectiveness of Ultrasound Locating Devices for Central Venous Access: A Systematic Review and Economic Evaluation, *Health Technology Assessment*, vol. 7, No. 12, 2003.
- Cardella, John F. et al., Interventinal Radiologic Placement of Peripherally Inserted Central Catheters, *Journal of Vascular and Interventional Radiology* 1993; 4:653-660.
- Carlson, R et al, Secondary Migration of a Central Venous Catheter—A Case Report, *Minerva Anestesiologica*, pp. 927-931, vol. 69 No. 12, Dec. 2003.
- Caruso, LJ et al, A Better Landmark for Positioning a Central Venous Catheter, *J Clinical Monitoring and Computing*, pp. 331-334, vol. 17 No. 6, Aug. 2002.
- Cavatorta, et al., "Central Venous Catheter Placement in Hemodialysis: Evaluation of Electrocardiography Using a Guidewire." *The Journal of Vascular Access*, vol. 2, pp. 45-50, 2001.
- Chalkiadis, GA et al, Depth of Central Venous Catheter Insertion in Adults: An Audit and Assessment of a Technique to Improve Tip Position, *Anaesth Intensive Care*, pp. 61-66, vol. 26 No. 1, Feb. 1998.
- Chamsi-Pasha, Hassan et al, Cardiac Complications of Total Parenteral Nutrition: The Role of Two-Dimensional Echocardiography in Diagnosis, *Annals of the Royal College of Surgeons of England*, pp. 120-123, vol. 71, 1989.
- Chang, Thomas C. et al., Are Routine Ch Ladiographs Necessary After Image-Guided Placement of Internal Jugular Central Venous Access Devices?, *AJR* Feb. 1998;170:335-337.
- Chaturvedi et al., "Catheter Malplacement During Central Venous Cannulation Through Arm Veins in Pediatric Patients." *Journal of Neurosurgical Anesthesiology*, vol. 15, No. 3 pp. 170-175, Jan. 2003.
- Chen, Zhongping et al, Optical Doppler Tomography: Imaging in vivo Blood Flow Dynamics Following Pharmacological Intervention and Photodynamic Therapy, 7 pages, vol. 67, *Photochemistry and Photobiology*, 1998.
- Cheng, KI et al, A Novel Approach of Intravenous Electrocardiograph Technique in Correct Position the Long-Term Central Venous Catheter, *Kaohsiung J Med Sci*, pp. 241-247, vol. 16 No. 5, May 2000 (Abstract only).
- Cheung, R, et al., The Effect of a Disposable Probe Cover on Pulse Oximetry, *Anaesth Intensive Care* 2002; 30: 211-214.
- CN 201380051172.5 filed Mar. 30, 2015 Office Action dated May 2, 2017.
- CN 201380065663.5 filed Jun. 15, 2015 Office Action dated Oct. 10, 2017.
- CN 201510144728.6 filed Apr. 17, 2015 Office Action dated Aug. 29, 2017.
- EP 10786978.6 filed Dec. 19, 2011 Office Action dated Aug. 11, 2017.
- EP 11827551.0 filed Feb. 7, 2013 Extended European Search Report dated Sep. 19, 2017.
- EP 11850625.2 filed Jul. 22, 2013 Extended European Search Report dated Jun. 21, 2017.
- EP 14197137.4 filed Dec. 10, 2014 Extended European Search Report dated Nov. 4, 2015.
- EP 14197137.4 filed Dec. 10, 2014 Office Action dated, Sep. 20, 2017.
- EP 14197137.4 filed Dec. 10, 2014, Partial European Search Report dated May 29, 2015.
- EP 14761249.3 Filed Sep. 3, 2015 Office Action dated Sep. 28, 2017.
- EP 15746326.6 filed Jul. 1, 2016 Extended European Search Report dated Jun. 9, 2017.
- EP 17157118.5 filed Feb. 21, 2017 Extended European Search Report dated Jun. 8, 2017.
- JP 2015-534770 filed Mar. 26, 2015 Office Action dated Jun. 12, 2017.
- KR 10-2013-7006933 filed Mar. 19, 2013 Office Action dated Aug. 7, 2017.
- RU 2015111669 filed Apr. 1, 2015 Office Action dated Sep. 5, 2017.
- U.S. Appl. No. 12/545,762, filed Aug. 21, 2009 Notice of Panel Decision dated Jul. 14, 2017.
- U.S. Appl. No. 13/887,166, filed May 3, 2013 Appeal Decision dated Aug. 17, 2017.
- U.S. Appl. No. 13/887,166, filed May 3, 2013 Notice of Allowance dated Nov. 6, 2017.
- U.S. Appl. No. 14/040,205, filed Sep. 27, 2013 Examiner's Answer dated Jul. 20, 2017.
- U.S. Appl. No. 14/054,700, filed Oct. 15, 2013 Examiner's Answer dated Jul. 3, 2017.
- U.S. Appl. No. 14/201,300, filed Mar. 7, 2014 Final Office Action dated Jul. 10, 2017.
- U.S. Appl. No. 14/548,151, filed Nov. 19, 2014 Advisory Action dated Aug. 1, 2017.
- U.S. Appl. No. 14/548,151, filed Nov. 19, 2014 Non-Final Office Action dated Sep. 21, 2017.
- U.S. Appl. No. 14/788,305, filed Jun. 30, 2015 Restriction Requirement dated Aug. 25, 2017.
- U.S. Appl. No. 15/160,958, filed May 20, 2016 Advisory Action dated Jul. 10, 2017.
- U.S. Appl. No. 15/160,958, filed May 20, 2016 Notice of Allowance dated Jul. 26, 2017.
- U.S. Appl. No. 15/585,051 filed May 2, 2017 Non-Final Office Action dated Jul. 14, 2017.
- CA 2800810 filed Nov. 26, 2012 Office Action dated Mar. 30, 2017.
- CN 200980144663.8 filed May 9, 2011 Decision of Re-Examination dated Feb. 21, 2017.
- CN 201380065663.5 filed Jun. 15, 2015 Office Action dated Mar. 15, 2017.
- CO 15110530 filed May 14, 2015 Office Action dated May 8, 2017.
- EP 09743249.6 filed Oct. 18, 2010 Intention to Grant dated Mar. 2, 2017.
- EP 13840356.3 filed Apr. 27, 2015 Extended European Search Report dated Mar. 22, 2017.
- JP 2013-530322 filed Mar. 18, 2013, Office Action dated Mar. 2, 2017.
- U.S. Appl. No. 12/545,762, filed Aug. 21, 2009 Final Office Action dated Apr. 10, 2017.
- U.S. Appl. No. 13/665,420, filed Oct. 31, 2012 Non-Final Office Action dated Mar. 15, 2017.
- U.S. Appl. No. 13/890,158, filed May 8, 2013 Non-Final Office Action dated Apr. 7, 2017.

(56)

References Cited

OTHER PUBLICATIONS

U.S. Appl. No. 14/141,046, filed Dec. 26, 2013 Non-Final Office Action dated Apr. 7, 2017.

U.S. Appl. No. 14/201,300, filed Mar. 7, 2014 Advisory Action dated Mar. 2, 2017.

U.S. Appl. No. 14/201,300, filed Mar. 7, 2014 Non-Final Office Action dated Mar. 30, 2017.

U.S. Appl. No. 14/548,151, filed Nov. 19, 2014 Final Office Action dated Apr. 19, 2017.

U.S. Appl. No. 15/160,958, filed May 20, 2016 Final Office Action dated Apr. 21, 2017.

U.S. Appl. No. 15/284,355, filed Oct. 3, 2016 Non-Final Office Action dated Apr. 24, 2017.

Chu, et al., "Accurate Central Venous Port—A Catheter Placement: Intravenous Electrocardiography and Surface Landmark Techniques Compared by Using Transesophageal Echocardiography." *The International Anesthesia Research Society*, vol. 98, pp. 910-914, 2004.

Claasz, Antonia et al, A Study of the Relationship of the Superior Vena Cava to the Bony Landmarks of the Sternum in the Supine Adult: Implications for Magnetic Guidance Systems, *Journal*, vol. 12 No. 3, JAVA, Jul. 24, 2007.

Clifford, et al. "Assessment of Hepatic Motion Secondary to Respiration for Computer Assisted Interventions." *Computer Aided Surgery*, vol. 7, pp. 291-299, 2002.

CN 200880012117.4 filed Apr. 16, 2008 First Office Action dated Dec. 23, 2011.

CN 200880012117.4 filed Apr. 16, 2008 Fourth Office Action dated Sep. 4, 2013.

CN 200880012117.4 filed Apr. 16, 2008 Second Office Action dated Oct. 8, 2012.

CN 200880012117.4 filed Apr. 16, 2008 Third Office Action dated Apr. 27, 2013.

CN 200880125528.4 filed Nov. 25, 2008 First Office Action dated Jun. 5, 2012.

CN 200880125528.4 filed Nov. 25, 2008 Second Office Action dated Mar. 6, 2013.

CN 200880125528.4 filed Nov. 25, 2008 Third Office Action dated Jul. 1, 2013.

CN 200980123021.X filed Dec. 17, 2010 First Office Action dated Nov. 19, 2012.

CN 200980123021.X filed Dec. 17, 2010 Second Office Action dated Aug. 13, 2013.

CN 200980123021.X filed Dec. 17, 2010 Third Office Action dated Apr. 22, 2014.

CN 200980144663.8 filed May 9, 2011 Fifth Office Action dated May 26, 2015.

CN 200980144663.8 filed May 9, 2011 First Office Action dated Dec. 5, 2012.

CN 200980144663.8 filed May 9, 2011 Fourth Office Action dated Nov. 15, 2014.

CN 200980144663.8 filed May 9, 2011 Second Office Action dated Aug. 22, 2013.

CN 200980144663.8 filed May 9, 2011 Third Office Action dated May 4, 2014.

CN 201080035659.0 filed Feb. 10, 2012 First Office Action dated Jan. 26, 2014.

CN 201080035659.0 filed Feb. 10, 2012 Second Office Action dated Oct. 9, 2014.

CN 201080035659.0 filed Feb. 10, 2012 Third Office Action dated Mar. 19, 2015.

CN 201080053838.7 filed May 28, 2012 First Office Action dated Jan. 6, 2014.

CN 201080053838.7 filed May 28, 2012 Fourth Office Action dated Jun. 2, 2015.

CN 201080053838.7 filed May 28, 2012 Second Office Action dated Jun. 17, 2014.

CN 201080053838.7 filed May 28, 2012 Third Office Action dated Dec. 4, 2014.

CN 201180016462.7 filed Sep. 27, 2012 First Office Action dated Mar. 21, 2014.

CN 201180016462.7 filed Sep. 27, 2012 Second Office Action dated Dec. 9, 2014.

CN 201180016462.7 filed Sep. 27, 2012 Third Office Action dated Jun. 10, 2015.

CN 201180037065.8 filed Jan. 28, 2013 First Office Action dated Sep. 28, 2014.

CN 201180037065.8 filed Jan. 28, 2013 Fourth Office Action dated May 5, 2016.

CN 201180037065.8 filed Jan. 28, 2013 Notice of Grant dated Aug. 30, 2016.

CN 201180037065.8 filed Jan. 28, 2013 Second Office Action dated Jun. 2, 2015.

CN 201180037065.8 filed Jan. 28, 2013 Third Office Action dated Nov. 24, 2015.

CN 201180037068.1 filed Jan. 28, 2013 First Office Action dated Apr. 20, 2015.

CN 201180037068.1 filed Jan. 28, 2013 First Office Action dated Sep. 9, 2014.

CN 201180037068.1 filed Jan. 28, 2013 Third Office Action dated Oct. 19, 2015.

CN 201180040151.4 filed Feb. 19, 2013 First Office Action dated Oct. 28, 2014.

CN 201180040151.4 filed Feb. 19, 2013 Office Action dated Dec. 10, 2015.

CN 201180040151.4 filed Feb. 19, 2013 Second Office Action dated Jun. 19, 2015.

CN 201180043512.0 filed Mar. 8, 2013 First Office Action dated Jul. 31, 2014.

CN 201180043512.0 filed Mar. 8, 2013 Second Office Action dated Apr. 14, 2015.

CN 201180052587.5 filed Apr. 28, 2013 First Office Action dated Jan. 26, 2015.

CN 201180052587.5 filed Apr. 28, 2013 Office Action dated Feb. 24, 2016.

CN 201180052587.5 filed Apr. 28, 2013 Second Office Action dated Aug. 19, 2015.

CN 201180068309.9 filed Aug. 22, 2013 First Office Action dated Oct. 16, 2014.

CN 201180068309.9 filed Aug. 22, 2013 Second Office Action dated May 6, 2015.

CN 201180068309.9 filed Aug. 22, 2013 Third Office Action dated Sep. 2, 2015.

CN 201280033189.3 filed Jan. 3, 2014 First Office Action dated Apr. 3, 2014.

CN 201280033189.3 filed Jan. 3, 2014 Second Office Action dated Sep. 14, 2015.

CN 201410009216.4 filed Jan. 8, 2014 Office Action dated Jun. 15, 2016.

PCT/US2010/050773 filed Sep. 29, 2010 Written Opinion dated Jan. 24, 2011.

PCT/US2010/051917 filed Oct. 8, 2010 Search Report dated Nov. 29, 2010.

PCT/US2010/051917 filed Oct. 8, 2010 Written Opinion dated Nov. 29, 2010.

PCT/US2011/023497 filed Feb. 2, 2011 Search Report dated Jun. 6, 2011.

PCT/US2011/023497 filed Feb. 2, 2011 Written Opinion dated Jun. 6, 2011.

PCT/US2011/038391 filed May 27, 2011 International Preliminary Report on Patentability and Written Opinion dated Dec. 4, 2012.

PCT/US2011/038391 filed May 27, 2011 International Search Report dated Sep. 21, 2011.

PCT/US2011/038415 filed May 27, 2011 International Preliminary Report on Patentability dated Dec. 13, 2012.

PCT/US2011/038415 filed May 27, 2011 International Search Report dated Sep. 28, 2011.

PCT/US2011/038415 filed May 27, 2011 Written Opinion dated Sep. 28, 2011.

PCT/US2011/047127 filed Aug. 9, 2011 International Preliminary Report on Patentability dated Apr. 18, 2013.

(56)

References Cited

OTHER PUBLICATIONS

- PCT/US2011/047127 filed Aug. 9, 2011 International Search Report dated Feb. 29, 2012.
- PCT/US2011/047127 filed Aug. 9, 2011 Written Opinion dated Feb. 29, 2012.
- PCT/US2011/048403 filed Aug. 19, 2011 International Preliminary Report on Patentability dated Jul. 30, 2013.
- PCT/US2011/048403 filed Aug. 19, 2011 International Search Report dated Dec. 15, 2011.
- PCT/US2011/048403 filed Aug. 19, 2011 Written Opinion dated Dec. 15, 2011.
- PCT/US2011/052793 filed Sep. 22, 2011 International Preliminary Report on Patentability dated Apr. 4, 2013.
- PCT/US2011/052793 filed Sep. 22, 2011 International Search Report dated Jan. 6, 2012.
- PCT/US2011/052793 filed Sep. 22, 2011 Written Opinion dated Jan. 6, 2012.
- PCT/US2011/058138 filed Oct. 27, 2011 International Preliminary Report on Patentability dated May 10, 2013.
- PCT/US2011/058138 filed Oct. 27, 2011 International Search Report dated Feb. 7, 2012.
- PCT/US2011/058138 filed Oct. 27, 2011 Written Opinion dated Feb. 7, 2012.
- PCT/US2011/067268 filed Dec. 23, 2011 International Preliminary Report on Patentability dated Jul. 4, 2013.
- PCT/US2011/067268 filed Dec. 23, 2011 International Search Report and Written Opinion dated Apr. 27, 2012.
- PCT/US2012/045814 filed Jul. 6, 2012 International Search Report and Written Opinion dated Oct. 1, 2012.
- PCT/US2013/065121 filed Oct. 15, 2013 International Search Report and Written Opinion dated Jan. 16, 2014.
- PCT/US2014/022019 filed Mar. 7, 2014 International Search Report and Written Opinion dated Jun. 11, 2014.
- PCT/US2015/014795 filed Feb. 6, 2015 International Search Report and Written Opinion dated May 14, 2015.
- Pennington, C.R., Right Atrial Thrombus: a Complication of Total Parenteral Nutrition, *British Medical Journal*, pp. 446-447, vol. 295, Aug. 15, 1987.
- Petersen, J et al, Silicone Venous Access Devices Positioned with their Tip High in the Superior Vena Cava are More Likely to Malfunction, *Am J Surg*, pp. 38-41, vol. 178 No. 1, Jul. 1999.
- Pittiruti, et al, "The intracavitary ECG method for positioning the tip of central venous catheters: results of an Italian multicenter study," *J Vasc Access*, pp. 1-9, Nov. 21, 2011.
- Pittiruti, et al, Intracavitary EKG Monitoring: A reliable method for controlling tip position during and after PICC Insertion presentation in Catholic University, Rome, Italy in 2008.
- Pittiruti, et al. "The EKG Method for Positioning the Tip of PICCs: Results from Two Preliminary Studies." *JAVA*, vol. 13, No. 4, pp. 179-185, 2008.
- Pittiruti, et al. "The electrocardiographic method for positioning the tip of central venous catheters" *JAVA*, pp. 1-12, Feb. 12, 2011.
- Polos, PG et al, Tips for Monitoring the Position of a Central Venous Catheter—How Placement can go awry—even when the anatomy is normal, *J Crit Illn*, pp. 660-674, vol. 8 No. 6, Jun. 1993 (Abstract only).
- Pop, Gheorghe A. et al., Catheter-based impedance measurements in the right atrium for continuously monitoring hematocrit and estimating blood viscosity changes; an in vivo feasibility study in swine, *Biosensors and Bioelectronics* 19 (2004) 1685-1693.
- Popp, M. B. et al., Accuracy of implanted port placement with the use of the electromagnetic CathTrack® catheter locator system, *The Journal of Vascular Access* 2005; 6: 9-12.
- Randolph AG et al, Ultrasound guidance for placement of central venous catheters: a meta-analysis of the literature, *Critical Care Medicine*, pp. 2053-2058, vol. 24, Dec. 1996.
- Reece, A et al, Positioning Long Lines: Contrast Versus Plain Radiography, *Arch Dis Child Fetal Neonatal Ed*, pp. 129-130, vol. 84 No. 2, Mar. 2001.
- Reynolds, N et al, Assessment of Distal Tip Position of Long Term Central Venous Feeding Catheters using Transesophageal Echocardiology, *JPEN J Parenter Enteral Nutr*, pp. 39-41, vol. 25 No. 1, Jan.-Feb. 2001.
- RU 2011150917 filed Dec. 15, 2011 First Office Action dated Apr. 24, 2014.
- RU 2011150917 filed Dec. 15, 2011 Second Office Action dated Aug. 28, 2014.
- RU 2013158008 filed Dec. 26, 2013 First Office Action dated May 27, 2016.
- Ruschulte, Heiner et al, Prevention of Central Venous Catheter related infections with chlorhexidine gluconate impregnated wound dressings: A randomized controlled trial, presented as an abstract at the Annual meeting of the European Society of Anaesthesiologists (ESA) in Madrid, Spain in Jun. 2006, 12 pages, *Annals of Hematology*, Jul. 14, 2008.
- Rutherford, J. S. et al., Depth of Central Venous Catheterization: An Audit of Practice in a Cardiac Surgical Unit, *Anaesth Intens Care* 1994; 22: 267-271.
- Sacolick, et al. "Electromagnetically Tracked Placement of a Peripherally Inserted Central Catheter." SPIE Medical Imaging, 2004 Proceedings.
- Salem, et al. "A New Peripherally Implanted Subcutaneous Permanent Central Venous Access Device for Patients Requiring Chemotherapy." *Journal of Clinical Oncology*, vol. 11, No. 11, pp. 2181-2185, Nov. 1993.
- Savary, D et al, Intra-atrial Monitoring to Add Insertion of a Central Venous Line in Pre-Hospital Emergency Care *Journal Europeen des Urgences*, pp. 75-78, vol. 17 No. 2, 2004.
- Schafer et al. "Incorrect placement of a vena cava catheter and its prevention by intra-atrial ECG." *Anaesthetist*. Jan. 1988;37(1):49-51.
- Schummer, et al. "Central Venous Catheters—The inability of 'intra-atrial ECG' to prove adequate positioning." *British Journal of Anaesthesia*, vol. 93, No. 2, pp. 193-198, 2004.
- CN 201410009216.4 filed Jan. 8, 2014 Second Office Action dated Sep. 25, 2015.
- Colley, Peter S et al, ECG-Guided Placement of Sorenson CVP Catheters via Arm Veins, *Anesthesia and Analgesia*, pp. 953-956, vol. 63, 1984.
- Collier, PE et al, Cardiac Tamponade from Central Venous Catheters, *Am J Surg*, pp. 212-214, vol. 176 No. 2, Aug. 1998.
- ComboWire® Pressure/Flow Guide Wire Ref 9500 Series, Instructions for Use, Apr. 2011.
- Corsten, et al., "Central Placement Catheter Placement Using the ECG-Guided Cavafix-Certodyn SD Catheter." *Journal of Clinical Anesthesiology*, vol. 6, Nov./Dec. 1994.
- Cucchiara, Roy et al, Time Required and Success Rate of Percutaneous Right Atrial Catheterization: Description of a Technique, *Canad. Anaesth. Soc. J.*, pp. 572-573, vol. 27, No. 6, Nov. 1980.
- Cullinane, DC et al, The Futility of Chest Roentgenograms Following Routine Central Venous Line Changes, *Am J Surg*, pp. 283-285, vol. 176 No. 3, Sep. 1998.
- Curet, Myriam J. et al., University and Practice-based Physicians' Input on the Content of a Surgical Curriculum, *The American Journal of Surgery*® vol. 178 Jul. 1999, 78-84.
- David, et al., "Is ECG-Guidance a Helpful Method to Correctly Position a Central Venous Catheter During Prehospital Emergency Care?" *Acta Anaesthesiologica Scandinavica*, vol. 49, pp. 1010-1014, 2005.
- Deltac Cath-Finder® Tracking System Operation Manual, 1994.
- Egelhof, Petra, Effects of Somatostatin on Portal Blood Flow and Portal Vein Pressure in Patients with Portal Hypertension due to Liver Cirrhosis Invasive Monitoring during Tipss Procedures, Dissertation submitted to: Technical University of Munich, Faculty of Medicine, May 13, 2002; Date of examination: Feb. 26, 2003.
- Engelhardt, W et al, ECG-Controlled Placement of Central Venous Catheters in Patients with Atrial Fibrillation, *Anaesthesist*, pp. 476-479, vol. 38 No. 9, Sep. 1989 (Abstract only).
- EP 08855396.1 filed Jun. 15, 2010 European Search Report dated Jul. 31, 2012.
- EP 08855396.1 filed Jun. 15, 2010 Intent to Grant dated Jul. 5, 2013.

(56)

References Cited

OTHER PUBLICATIONS

- EP 09707467.8 supplemental European search report dated Jun. 18, 2013.
- EP 09743249.6 filed Oct. 18, 2010 Extended European Search Report dated Jan. 13, 2016.
- EP 09808901.4 filed Aug. 21, 2009 European Search Report dated May 23, 2012.
- EP 09808901.4 filed Aug. 21, 2009 Examination Report dated May 10, 2013.
- EP 09813632.8 filed Apr. 5, 2011 European Search Report dated Jul. 4, 2012.
- EP 09813632.8 filed Apr. 5, 2011 Office Action dated Apr. 30, 2013.
- EP 09813632.8 filed Apr. 5, 2011 Summons to Attend Oral Proceedings dated Apr. 16, 2014.
- EP 10 808 660.4 filed Feb. 15, 2012 Extended European Search Report dated Mar. 4, 2014.
- EP 10786978.6 filed Dec. 19, 2011 Extended European Search Report dated Mar. 7, 2014.
- EP 10821193.9 filed Mar. 27 2012 Partial European Search Report dated Oct. 9, 2015.
- EP 11 818 828.3 filed Mar. 18, 2013 Extended European Search Report dated Dec. 10, 2014.
- EP 11740309.7 filed Aug. 23, 2012 Extended European Search Report dated Aug. 3, 2015.
- EP 11787515.3 filed Dec. 12, 2012 partial European search report dated Jun. 23, 2015.
- EP 11787515.3 filed Dec. 12, 2012 partial European search report dated Oct. 27, 2015.
- EP 11787527.8 filed Dec. 19 2012 Extended European Search Report dated Oct. 9, 2015.
- EP 11787527.8 filed Dec. 19, 2012 partial European search report dated May 26, 2015.
- EP 11837113.7 filed May 28, 2013 Extended European Search Report dated Apr. 24, 2014.
- EP 12177438.4 filed Jul. 23, 2012 Communication dated Jan. 13, 2014.
- EP 12177438.4 filed Jul. 23, 2012 European Search Report dated Dec. 4, 2012.
- EP 12177438.4 filed Jul. 23, 2012 European Search Report dated Jun. 7, 2015.
- EP 12177438.4 filed Jul. 23, 2012 Examination Report dated Dec. 5, 2014.
- EP 12177438.4 filed Jul. 23, 2012 extended European Search Report dated Mar. 25, 2013.
- EP 12807886.2 filed Jan. 15, 2014 Extended European Search Report dated Feb. 6, 2015.
- EP 13194818.4 filed Nov. 28, 2013 extended European search report dated Feb. 28, 2014.
- EP 14151268.1 filed Jan. 15, 2014 European Search Report dated Feb. 21, 2014.
- EP 15179061.5 filed Jul. 30, 2015 Extended European Search Report dated Jan. 14, 2016.
- EP14197136.6 filed Dec. 10, 2014 Extended European Search Report dated May 26, 2015.
- Fearon, William F et al, Evaluating Intermediate Coronary Lesions in the Cardiac Catheterization Laboratory, vol. 4, No 1, 7 pages, Reviews in Cardiovascular Medicine, 2003.
- Felleiter P et al, Use of Electrocardiographic Placement Control of Central Venous Catheters in Austria, Acta Med Austriaca, pp. 109-113, vol. 26 No. 3, 1999 (Abstract only).
- Forauer, AR et al, Change in Peripherally Inserted Central Catheter Tip Location with Abduction and Adduction of the Upper Extremity, J Vasc Interv Radiol, pp. 1315-1318, vol. 11 No. 10, Nov.-Dec. 2000.
- Frassinelli, P et al, Utility of Chest Radiographs after Guidewire Exchanges of Central Venous Catheters, Crit Care Med, pp. 611-615, vol. 26 No. 3, Mar. 1998.
- Frazin L et al, A Doppler Guided Retrograde Catheterization System, Cathet. Cardiovasc Diagn, pp. 41-50, May 1992.
- French, PJ et al, Sensors for Catheter Applications, Sensors Update, vol. 13 Issue 1 pp. 107-153, Dec. 2003.
- GB Application 0800474.9 filed Aug. 24, 2006 Office Action dated Aug. 9, 2010.
- GB Application 0800474.9 filed Aug. 24, 2006 Office Action dated Mar. 17, 2010.
- Gebauer, B et al, Ultrasound and Fluoroscopy-guided Implantation of Peripherally Inserted Central Venous Catheters (PICCs), ROFO, pp. 386-391, vol. 176 No. 3, Mar. 2004 (Abstract only).
- U.S. Appl. No. 12/557,401, filed Sep. 10, 2009 Non-Final Office Action dated Jan. 6, 2014.
- U.S. Appl. No. 12/575,456, filed Oct. 7, 2009 Non-Final Office Action dated Oct. 5, 2012.
- U.S. Appl. No. 12/715,556, filed Mar. 2, 2010 Final Office Action dated Oct. 2, 2013.
- U.S. Appl. No. 12/715,556, filed Mar. 2, 2010 Non-Final Office Action dated Sep. 13, 2012.
- U.S. Appl. No. 12/815,331, filed Jun. 14, 2010 Advisory Action dated Mar. 5, 2015.
- U.S. Appl. No. 12/815,331, filed Jun. 14, 2010 Advisory Action dated Oct. 4, 2013.
- U.S. Appl. No. 12/815,331, filed Jun. 14, 2010 Final Office Action dated Dec. 23, 2014.
- U.S. Appl. No. 12/815,331, filed Jun. 14, 2010 Final Office Action dated Jul. 26, 2013.
- U.S. Appl. No. 12/815,331, filed Jun. 14, 2010 Final Office Action dated Nov. 4, 2015.
- U.S. Appl. No. 12/815,331, filed Jun. 14, 2010 Non-Final Office Action dated Jan. 22, 2013.
- U.S. Appl. No. 12/815,331, filed Jun. 14, 2010 Non-Final Office Action dated Jul. 2, 2014.
- U.S. Appl. No. 12/815,331, filed Jun. 14, 2010 Non-Final Office Action dated Jun. 1, 2015.
- U.S. Appl. No. 12/854,083, filed Aug. 10, 2010 Advisory Action dated Sep. 8, 2014.
- U.S. Appl. No. 12/854,083, filed Aug. 10, 2010 Final Office Action dated Aug. 15, 2013.
- U.S. Appl. No. 12/854,083, filed Aug. 10, 2010 Final Office Action dated Aug. 21, 2015.
- U.S. Appl. No. 12/854,083, filed Aug. 10, 2010 Final Office Action dated Jul. 1, 2014.
- U.S. Appl. No. 12/854,083, filed Aug. 10, 2010 Non-Final Office Action dated Feb. 1, 2016.
- U.S. Appl. No. 12/854,083, filed Aug. 10, 2010 Non-Final Office Action dated Jan. 29, 2013.
- U.S. Appl. No. 12/854,083, filed Aug. 10, 2010 Non-Final Office Action dated Jan. 29, 2014.
- U.S. Appl. No. 12/854,083, filed Aug. 10, 2010 Non-Final Office Action dated Mar. 16, 2015.
- U.S. Appl. No. 12/878,915, filed Sep. 9, 2010 Final Office Action dated Sep. 26, 2012.
- U.S. Appl. No. 12/878,915, filed Sep. 9, 2010 Non-Final Office Action dated Mar. 15, 2012.
- U.S. Appl. No. 12/878,915, filed Sep. 9, 2010 Notice of Allowance dated Jan. 8, 2013.
- U.S. Appl. No. 12/893,916, filed Sep. 29, 2010 Advisory Action dated Aug. 15, 2014.
- U.S. Appl. No. 12/893,916, filed Sep. 29, 2010 Advisory Action dated Jun. 2, 2016.
- U.S. Appl. No. 12/893,916, filed Sep. 29, 2010 Final Office Action dated Jan. 15, 2015.
- U.S. Appl. No. 12/893,916, filed Sep. 29, 2010 Final Office Action dated Jun. 18, 2014.
- U.S. Appl. No. 12/893,916, filed Sep. 29, 2010 Final Office Action dated Mar. 25, 2016.
- U.S. Appl. No. 12/893,916, filed Sep. 29, 2010 Non-Final Office Action dated Aug. 31, 2016.
- U.S. Appl. No. 12/893,916, filed Sep. 29, 2010 Non-Final Office Action dated Dec. 24, 2013.
- U.S. Appl. No. 12/893,916, filed Sep. 29, 2010 Non-Final Office Action dated Sep. 10, 2015.
- U.S. Appl. No. 12/893,916, filed Sep. 29, 2010 Non-Final Office Action dated Sep. 25, 2014.

(56)

References Cited

OTHER PUBLICATIONS

- U.S. Appl. No. 12/900,750, filed Oct. 8, 2010 Non-Final Office Action dated Jun. 3, 2013.
- U.S. Appl. No. 13/019,939, filed Feb. 2, 2011 Final Office Action dated Apr. 2, 2014.
- U.S. Appl. No. 13/019,939, filed Feb. 2, 2011 Non-Final Office Action dated Feb. 9, 2015.
- U.S. Appl. No. 13/019,939, filed Feb. 2, 2011 Non-Final Office Action dated Oct. 11, 2011.
- U.S. Appl. No. 13/118,033, filed May 27, 2011 Final Office Action dated Apr. 1, 2016.
- U.S. Appl. No. 13/118,033, filed May 27, 2011 Non-Final Office Action dated Aug. 1, 2011.
- U.S. Appl. No. 13/118,033, filed May 27, 2011 Non-Final Office Action dated Feb. 3, 2015.
- U.S. Appl. No. 13/118,033, filed May 27, 2011 Non-Final Office Action dated Jul. 8, 2015.
- U.S. Appl. No. 13/118,033, filed May 27, 2011 Non-Final Office Action dated May 22, 2014.
- U.S. Appl. No. 13/118,138, filed May 27, 2011 Final Office Action dated Apr. 1, 2016.
- U.S. Appl. No. 13/118,138, filed May 27, 2011 Final Office Action dated Apr. 3, 2013.
- U.S. Appl. No. 13/118,138, filed May 27, 2011 Non-Final Office Action dated Jul. 15, 2015.
- U.S. Appl. No. 13/118,138, filed May 27, 2011 Non-Final Office Action dated Oct. 3, 2012.
- U.S. Appl. No. 13/118,138, filed May 27, 2011 Non-Final Office Action dated Oct. 9, 2014.
- U.S. Appl. No. 13/213,622, filed Aug. 19, 2011 Final Office Action dated Feb. 19, 2013.
- U.S. Appl. No. 13/213,622, filed Aug. 19, 2011 Non-Final Office Action dated Jul. 31, 2012.
- U.S. Appl. No. 13/213,622, filed Aug. 19, 2011 Non-Final Office Action dated May 22, 2014.
- U.S. Appl. No. 13/240,171, filed Sep. 22, 2011 Advisory Action dated Aug. 18, 2015.
- AU 2012278809 filed Nov. 12, 2013 Notice of Acceptance dated Sep. 13, 2016.
- CA 2,721,715 filed Apr. 17, 2009 Examiner's Report dated Oct. 25, 2016.
- CN 200980144663.8 filed May 9, 2011 Notice of Reexamination dated Aug. 5, 2016.
- CN 201510144728.6 filed Apr. 17, 2015 Office Action dated Jan. 23, 2017.
- CO 15110530 filed May 14, 2015 Office Action dated Nov. 25, 2016.
- EP 13840356.3 filed Apr. 27, 2015 Partial European Search Report dated Oct. 19, 2016.
- EP 13846380.7 filed May 15, 2015 Extended European Search Report dated Sep. 30, 2016.
- EP 13846380.7 filed May 15, 2015 Partial European Search Report dated Sep. 30, 2016.
- EP 14761249.3 Filed Sep. 3, 2015 Extended European Search Report dated Sep. 19, 2016.
- KR 10-2012-7000866 filed Jan. 11, 2012 Second Office Action dated Nov. 3, 2016.
- PCT/US2016/039356 filed Jun. 24, 2016 International Search Report and Written Opinion dated Sep. 16, 2016.
- U.S. Appl. No. 12/426,175, filed Apr. 17, 2009 Decision on Appeal dated Nov. 7, 2016.
- U.S. Appl. No. 12/426,175, filed Apr. 17, 2009 Notice of Allowance dated Dec. 13, 2016.
- U.S. Appl. No. 12/545,762, filed Aug. 21, 2009 Non-Final Office Action dated Sep. 26, 2016.
- Js 13/118,033 filed May 27, 2011 Notice of Allowance dated Sep. 2, 2016.
- U.S. Appl. No. 13/469,93, filed May 11, 2012 Notice of Allowance dated Jan. 31, 2017.
- U.S. Appl. No. 14/040,205, filed Sep. 27, 2013 Advisory Action dated Dec. 15, 2016.
- U.S. Appl. No. 14/040,205, filed Sep. 27, 2013 Final Office Action dated Oct. 19, 2016.
- U.S. Appl. No. 14/054,700, filed Oct. 15, 2013 Advisory Action dated Dec. 15, 2016.
- U.S. Appl. No. 14/054,700, filed Oct. 15, 2013 Final Office Action dated Oct. 19, 2016.
- U.S. Appl. No. 14/201,300, filed Mar. 7, 2014 Final Office Action dated Dec. 19, 2016.
- U.S. Appl. No. 14/548,151, filed Nov. 19, 2014 Non-Final Office Action dated Sep. 28, 2016.
- U.S. Appl. No. 14/615,932, filed Feb. 6, 2015 Non-Final Office Action dated Dec. 29, 2016.
- U.S. Appl. No. 14/846,496, filed Sep. 4, 2015 Non-Final Office Action dated Nov. 25, 2016.
- U.S. Appl. No. 15/160,958, filed May 20, 2016 Non-Final Office Action dated Dec. 15, 2016.
- Schummer, W et al, ECG-guided Central Venous Catheter Positioning: Does it detect the Pericardial Reflection rather than the Right Atrium?, *Eur J Anaesthesiol*, pp. 600-605, vol. 21 No. 8, Aug. 2004 (Abstract only).
- Schummer, W et al, Intra-Atrial ECG is not a Reliable Method for Positioning Left Internal Jugular Vein Catheters, *Br J Anaesth*, pp. 481-486, vol. 91 No. 4, Oct. 2003.
- Schummer, W, Central Venous Catheter—the Inability of “Intra-Atrial ECG” to prove Adequate Positioning, *Br J Anaesth*, pp. 193-198, vol. 93 No. 2, Aug. 2004.
- Schuster, M. et al., The carina as a landmark in central venous catheter placement, *British Journal of Anaesthesia* 85 (2): 192-4 (2000).
- Siela, Debra, Using Chest Radiography in the Intensive Care Unit, *Crit Care Nurse* Aug. 1, 2002 vol. 22 No. 4, pp. 18-27.
- Simon, et al., “Central Venous Catheter Placement in Children: Evaluation of Electrocardiography Using J-Wire.” *Paediatric Anaesthesia* vol. 9, pp. 501-504, 1999.
- Smith, Brigham, et al., Intravenous electrocardiographic guidance for placement of peripherally inserted central catheters, *Journal of Electrocardiology* 43 (2010) 274-278.
- Stark, DD et al, Radiographic Assessment of Venous Catheter Position in Children: Value of the Lateral View, *Pediatric Radiology*, pp. 76-80, vol. 14 No. 2, 1984.
- Starkhammar et al. “Cath-Finder Catheter Tracking System: A New Device for Positioning of Central Venous Catheters. Early Experience from Implantation of Brachial portal Systems.” *Acta Anaesthesiol Scandinavica*, vol. 34, No. 4 pp. 296-300, May 1990.
- Starkhammer, H et al, Central Venous Catheter Placement using Electromagnetic Position Sensing: A Clinical Evaluation, *Biomed. Instrum Technol*, vol. 30 No. 2, pp. 164-170; Mar.-Apr. 1996.
- Starr, David S et al, EKG Guided Placement of Subclavian CVP Catheters Using J-Wire, pp. 673-676, *Ann. Surg.*, Dec. 1986.
- Stas, M et al, Peroperative Intravasal Electrographic Control of Catheter Tip Position in Access Ports Placed by Venous Cut-Down Technique, *EJSO*, pp. 316-320, vol. 27, 2001.
- Stereotaxis Magnetic Navigation System with Navigant™ User Interface, 2005 Brochure.
- Stereotaxis, Expanding the Possibilities of Interventional Medicine: Remote Navigation and Automation, pp. 1-8, Apr. 2011.
- Tepa® Health Innovation PC based ECG System Introduction and Technical Specifications, EKG Master USB, 2 pages, Nov. 2003.
- The FloWire Doppler Guide Wire located <<http://www.volcanocorp.com/products/fiowire-doppler-guide-wire.php>>, 2011.
- TRAXAL Technologies, Tracking Technology website overview: www.traxal.com/rd/rd_classroom_trackingtechnology.htm, last accessed Dec. 1, 2006.
- UAB Health Systems, Arrhythmias, retrieved from <http://www.health.uab.edu/14564/> on Nov. 15, 2007, 12 pages.
- U.S. Appl. No. 11/466,602, filed Aug. 23, 2006 Advisory Action dated Jun. 22, 2009.
- U.S. Appl. No. 11/466,602, filed Aug. 23, 2006 Appeal Board Decision dated Sep. 17, 2012.
- U.S. Appl. No. 11/466,602, filed Aug. 23, 2006 Final Office Action dated Apr. 8, 2010.

(56)

References Cited

OTHER PUBLICATIONS

- U.S. Appl. No. 11/466,602, filed Aug. 23, 2006 Final Office Action dated Jan. 30, 2009.
- U.S. Appl. No. 11/466,602, filed Aug. 23, 2006 Final Office Action dated Oct. 28, 2011.
- U.S. Appl. No. 11/466,602, filed Aug. 23, 2006 Non-Final Office Action dated Mar. 28, 2013.
- U.S. Appl. No. 11/466,602, filed Aug. 23, 2006 Non-Final Office Action dated Sep. 25, 2009.
- U.S. Appl. No. 11/466,602, filed Aug. 23, 2006 Notice of Allowance dated Dec. 3, 2012.
- U.S. Appl. No. 11/466,602, filed Aug. 23, 2006 Notice of Allowance dated Mar. 14, 2014.
- U.S. Appl. No. 11/552,094, filed Oct. 23, 2006 Notice of Allowability dated Apr. 2, 2010.
- U.S. Appl. No. 11/552,094, filed Oct. 23, 2006 Non-Final Office Action dated Apr. 27, 2009.
- U.S. Appl. No. 11/552,094, filed Oct. 23, 2006 Notice of Allowance dated May 20, 2010.
- U.S. Appl. No. 12/104,253, filed Apr. 16, 2008 Final Office Action dated Jul. 27, 2011.
- U.S. Appl. No. 12/104,253 filed Apr. 16, 2008 Non-Final Office Action dated Nov. 29, 2010.
- U.S. Appl. No. 12/323,273, filed Nov. 25, 2008 Non-Final Office Action dated Jun. 8, 2012.
- U.S. Appl. No. 12/369,625, filed Feb. 11, 2009 Final Office Action dated Feb. 23, 2012.
- U.S. Appl. No. 12/369,625, filed Feb. 11, 2009 Notice of Allowance dated Oct. 5, 2012.
- U.S. Appl. No. 12/369,625, filed Feb. 11, 2009 Notice of Panel Decision dated Aug. 1, 2012.
- U.S. Appl. No. 12/369,625, filed Feb. 11, 2009 Non-Final Office Action dated Jul. 20, 2011.
- U.S. Appl. No. 12/426,175, filed Apr. 17, 2009 Advisory Action dated Nov. 26, 2011.
- U.S. Appl. No. 12/426,175, filed Apr. 17, 2009 Examiner's Answer dated Oct. 7, 2014.
- U.S. Appl. No. 12/426,175, filed Apr. 17, 2009 Final Office Action dated Aug. 2, 2013.
- U.S. Appl. No. 12/426,175, filed Apr. 17, 2009 Final Office Action dated Jan. 31, 2014.
- U.S. Appl. No. 12/426,175, filed Apr. 17, 2009 Non-Final Office Action dated Dec. 3, 2012.
- U.S. Appl. No. 12/427,244, filed Apr. 21, 2009 Non-Final Office Action dated Jan. 19, 2012.
- U.S. Appl. No. 12/545,762, filed Aug. 21, 2009 Final Office Action dated Mar. 7, 2013.
- U.S. Appl. No. 12/545,762, filed Aug. 21, 2009 Non-Final Office Action dated Aug. 1, 2012.
- U.S. Appl. No. 12/545,762, filed Aug. 21, 2009 Non-Final Office Action dated Dec. 13, 2013.
- U.S. Appl. No. 12/545,762, filed Aug. 21, 2009 Non-Final Office Action dated Feb. 16, 2016.
- U.S. Appl. No. 12/545,762, filed Aug. 21, 2009 Non-Final Office Action dated Nov. 7, 2014.
- U.S. Appl. No. 12/545,762, filed Aug. 21, 2009 Non-Final Office Action dated Sep. 11, 2015.
- U.S. Appl. No. 12/557,401, filed Sep. 10, 2009 Non-Final Office Action dated Apr. 24, 2012.
- AZoMaterials. Nickel-Based Super Alloy Inconel 625—Properties and Applications by United Performance Alloys. Oct. 27, 2015. Last accessed Mar. 23, 2018. <URL:https://web.archive.org/web/20151027202821/https://www.azom.com/article.aspx?ArticleID=4461>.
- CA 2800810 filed Nov. 26, 2012 Office Action dated Mar. 13, 2018.
- CA 2800813 filed Nov. 26, 2012 Office Action dated Mar. 5, 2018.
- CN 201380051172.5 filed Mar. 30, 2015 Office Action dated Jan. 16, 2018.
- CN 201480010988.8 filed Aug. 27, 2015 Office Action dated Dec. 13, 2017.
- CN 201610127217.8 filed Mar. 7, 2016 Office Action dated Dec. 28, 2017.
- CN 201610166569.4 filed Dec. 23, 2010, Office Action dated Nov. 1, 2017.
- EP 14197137.4 filed Dec. 10, 2014 Office Action dated Apr. 5, 2018.
- EP 15179061.5 filed Jul. 30, 2015 Partial European Search Report dated Jan. 17, 2018.
- EP 17186624.7 filed Aug. 17, 2017 Extended European Search Report dated Jan. 17, 2018.
- EP 17186624.7 filed Aug. 17, 2017 Partial European Search Report dated Jan. 17, 2018.
- JP 2013-530322 filed Mar. 18, 2013, Office Action dated Nov. 6, 2017.
- JP 2015-534770 filed Mar. 26, 2015 Office Action dated Feb. 21, 2018.
- MX/a/2015/004864 filed Apr. 16, 2015 Office Action dated Apr. 24, 2018.
- MX/a/2015/004864 filed Apr. 16, 2015 Office Action dated Dec. 18, 2017.
- NOT Resource Center. Magnetic Permeability. Oct. 18, 2014. Last accessed Mar. 23, 2018. <URL:https://web.archive.org/web/20141018213902/https://www.nde-ed.org/EducationResources/CommunityCollege/Materials/Physical_Chemical/Permeability.htm>.
- PCT/US2017/066503 filed Dec. 14, 2017 International Search Report and Written Opinion dated Feb. 20, 2018.
- RU 2015111669 filed Apr. 1, 2015 Office Action dated Jan. 25, 2018.
- RU 2015111669 filed Apr. 1, 2015 Office Action dated May 18, 2018.
- U.S. Appl. No. 13/665,420, filed Oct. 31, 2012 Notice of Allowance dated Feb. 7, 2018.
- U.S. Appl. No. 13/890,158, filed May 8, 2013 Advisory Action dated Feb. 13, 2018.
- U.S. Appl. No. 13/890,158, filed May 8, 2013 Final Office Action dated Nov. 21, 2017.
- U.S. Appl. No. 13/890,158, filed May 8, 2013 Notice of Allowance dated May 30, 2018.
- U.S. Appl. No. 14/141,046, filed Dec. 26, 2013 Final Office Action dated Dec. 11, 2017.
- U.S. Appl. No. 14/201,300, filed Mar. 7, 2014 Examiner's Answer dated Apr. 19, 2018.
- U.S. Appl. No. 14/317,501, filed Jun. 27, 2014 Decision on Appeal dated Nov. 17, 2017.
- U.S. Appl. No. 14/317,501, filed Jun. 27, 2014 Notice of Allowance dated Feb. 9, 2018.
- U.S. Appl. No. 14/788,305, filed Jun. 30, 2015 Non-Final Office Action dated Jan. 10, 2018.
- U.S. Appl. No. 15/284,355, filed Oct. 3, 2016 Final Office Action dated May 24, 2018.
- U.S. Appl. No. 15/284,355, filed Oct. 3, 2016 Non-Final Office Action dated Nov. 17, 2017.
- U.S. Appl. No. 15/365,698, filed Nov. 30, 2016 Non-Final Office Action dated Dec. 14, 2017.
- U.S. Appl. No. 15/365,734, filed Nov. 30, 2016 Non-Final Office Action dated Feb. 23, 2018.
- U.S. Appl. No. 15/365,734, filed Nov. 30, 2016 Notice of Allowance dated Jun. 4, 2018.
- U.S. Appl. No. 15/365,752, filed Nov. 30, 2016 Non-Final Office Action dated Dec. 13, 2017.
- U.S. Appl. No. 15/365,872, filed Nov. 30, 2016 Restriction Requirement dated Apr. 5, 2018.
- U.S. Appl. No. 15/585,051, filed May 2, 2017 Final Office Action dated Feb. 28, 2018.
- U.S. Appl. No. 15/585,051, filed May 2, 2017 Final Office Action dated Mar. 15, 2018.
- U.S. Appl. No. 15/900,623, filed Feb. 20, 2018 Non-Final Office Action dated May 3, 2018.
- CN 201380051172.5 filed Mar. 30, 2015 Office Action dated Jul. 30, 2018.
- CN 201480010988.8 filed Aug. 27, 2015 Office Action dated Aug. 17, 2018.

(56)

References Cited

OTHER PUBLICATIONS

CN 201610127217.8 filed Mar. 7, 2016 Office Action dated Jun. 11, 2018.

Enrique Company-Bosch, "ECG Front-End Design is Simplified with MicroConverter." Analog Dialogue 37-11, (dated Nov. 2003). EP 11850625.2 filed Jul. 22, 2013 Office Action dated Sep. 24, 2018.

Hamza, N. et al. "Interference reduction in ECG signal acquisition: Ground electrode removal." 2013 International Conference on Computer Medical Applications (ICCA), Jan. 2013.

Honeywell, "1, 2 and 3 Axis Magnetic Sensors HMC1051/HMC1052L/HMC1053" dated Jan. 2010.

JP 2013-530322 filed Mar. 18, 2013, Office Action dated Jul. 6, 2018.

KR 10-2014-7002789 filed Feb. 3, 2014 Office Action dated Jun. 21, 2018.

Thakor, N. V. , et al. "Ground-Free ECG Recording with Two Electrodes." IEEE Transactions on Biomedical Engineering, vol. BME-27, No. 12, Dec. 1980.

U.S. Appl. No. 14/788,305, filed Jun. 30, 2015 Final Office Action dated Jul. 27, 2018.

U.S. Appl. No. 15/284,355, filed Oct. 3, 2016 Advisory Action dated Aug. 13, 2018.

U.S. Appl. No. 15/365,698, filed Nov. 30, 2016 Final Office Action dated Jul. 12, 2018.

U.S. Appl. No. 15/365,752, filed Nov. 30, 2016 Final Office Action dated Jul. 12, 2018.

U.S. Appl. No. 15/365,872, filed Nov. 30, 2016 Non-Final Office Action dated Aug. 27, 2018.

U.S. Appl. No. 15/900,623, filed Feb. 20, 2018 Final Office Action dated Sep. 20, 2018.

EP 14197137.4 filed Dec. 10, 2014, Office Action dated Nov. 21, 2018.

EP14197136.6 filed Dec. 10, 2014 Office Action dated Nov. 21, 2018.

U.S. Appl. No. 14/141,046, filed Dec. 26, 2013 Examiner's Answer dated Oct. 15, 2018.

U.S. Appl. No. 141788,305, filed Jun. 30, 2015 Advisory Action dated Oct. 19, 2018.

U.S. Appl. No. 14/788,305, filed Jun. 30, 2015 Notice of Allowance dated Nov. 15, 2018.

U.S. Appl. No. 15/266,977, filed Sep. 15, 2016 Non-Final Office Action dated Oct. 30, 2018.

U.S. Appl. No. 15/365,752, filed Nov. 30, 2016 Notice of Allowance dated Nov. 6, 2018.

EP 10786978.6, filed Dec. 19, 2011 Office Action dated Jan. 16, 2019.

EP 11850625.2, filed Jul. 22, 2013 Office Action dated Feb. 25, 2019.

EP 15746326.6, filed Jul. 1, 2016 Office Action dated Jan. 29, 2019.

KR 10-2014-7002789, filed Feb. 3, 2014 Office Action dated Feb. 22, 2019.

U.S. Appl. No. 15/284,355, filed Oct. 3, 2016 Notice of Allowance dated Feb. 21, 2019.

U.S. Appl. No. 15/365,872, filed Nov. 30, 2016 Notice of Allowance dated Dec. 21, 2018.

U.S. Appl. No. 14/040,205, filed Sep. 27, 2013 Board Decision dated May 1, 2019.

U.S. Appl. No. 14/054,700, filed Oct. 15, 2013 Board Decision dated May 1, 2019.

U.S. Appl. No. 14/201,300, filed Mar. 7, 2014 Board Decision dated Apr. 12, 2019.

U.S. Appl. No. 14/996,247, filed Jan. 15, 2016 Restriction Requirement dated Mar. 22, 2019.

U.S. Appl. No. 15/365,698, filed Nov. 30, 2016 Non-Final Office Action dated Apr. 18, 2019.

* cited by examiner

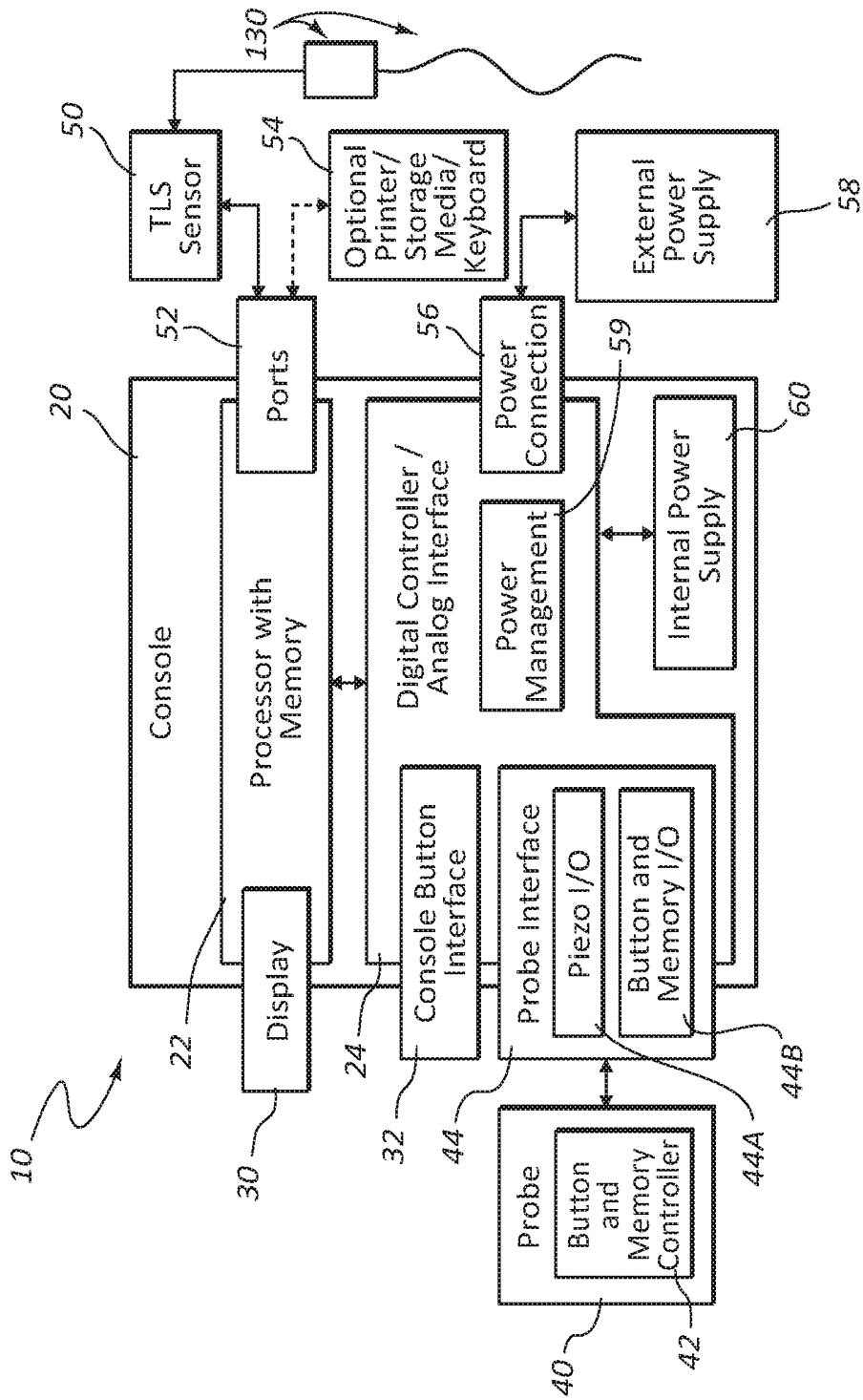

FIG. 1

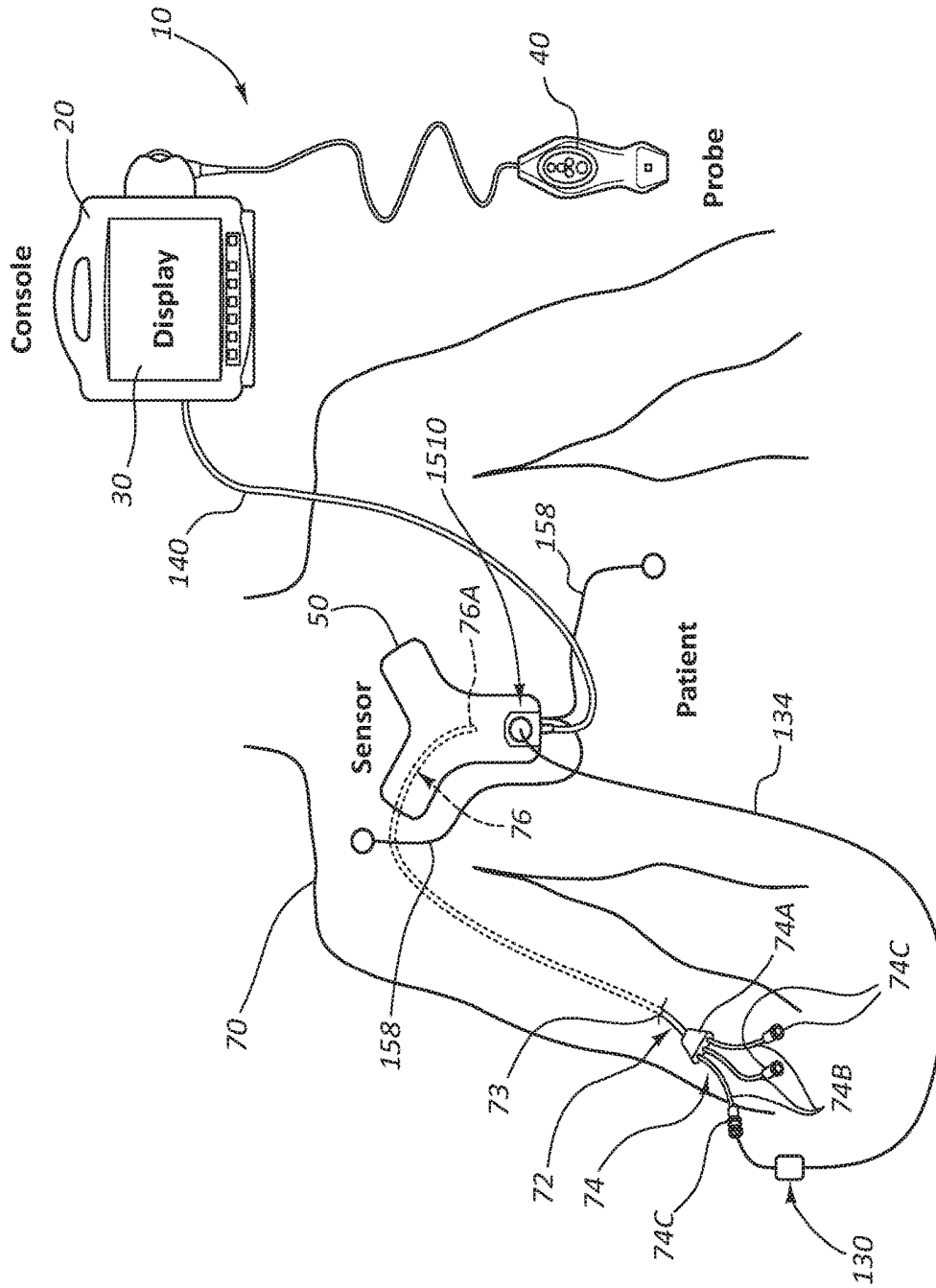

FIG. 2

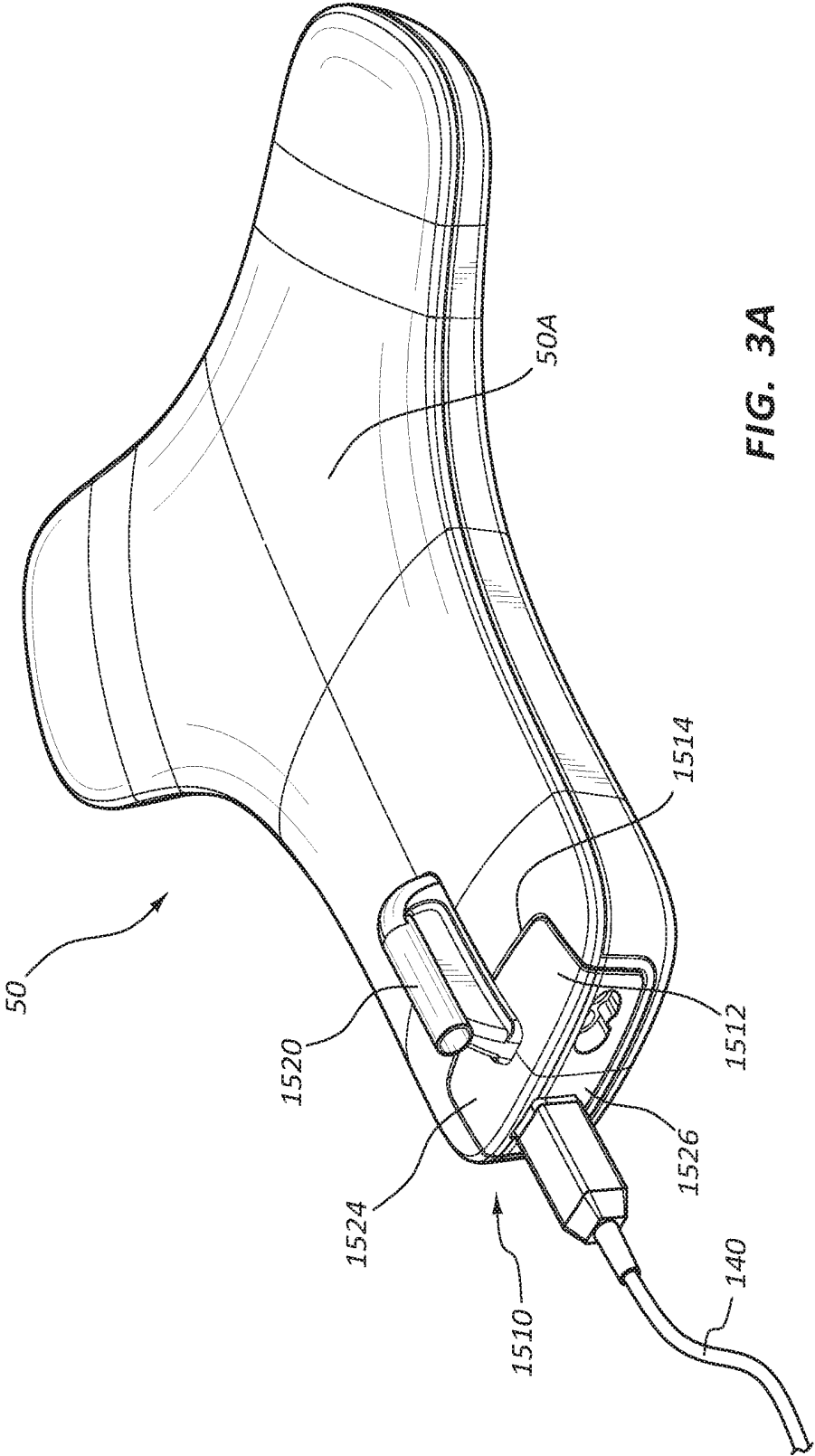

FIG. 3A

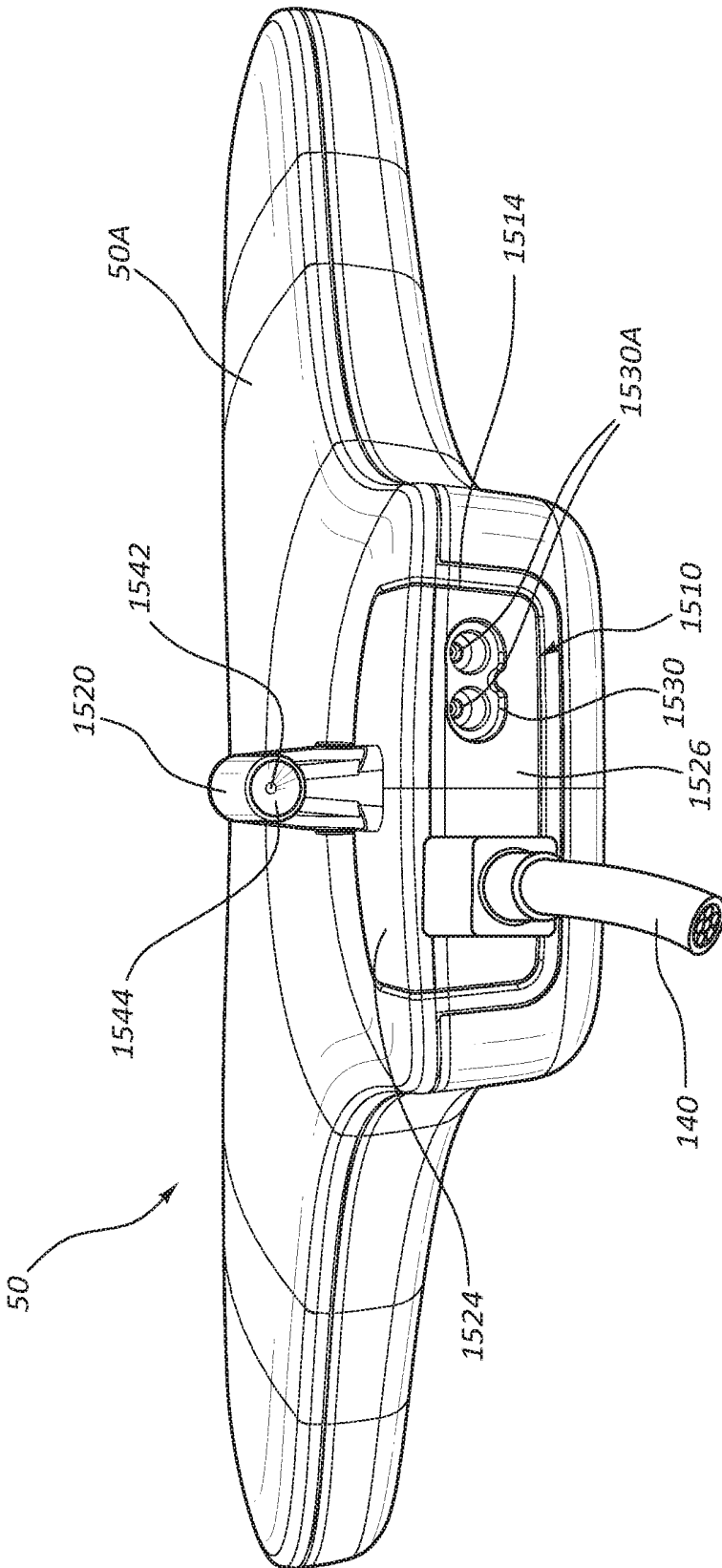

FIG. 3B

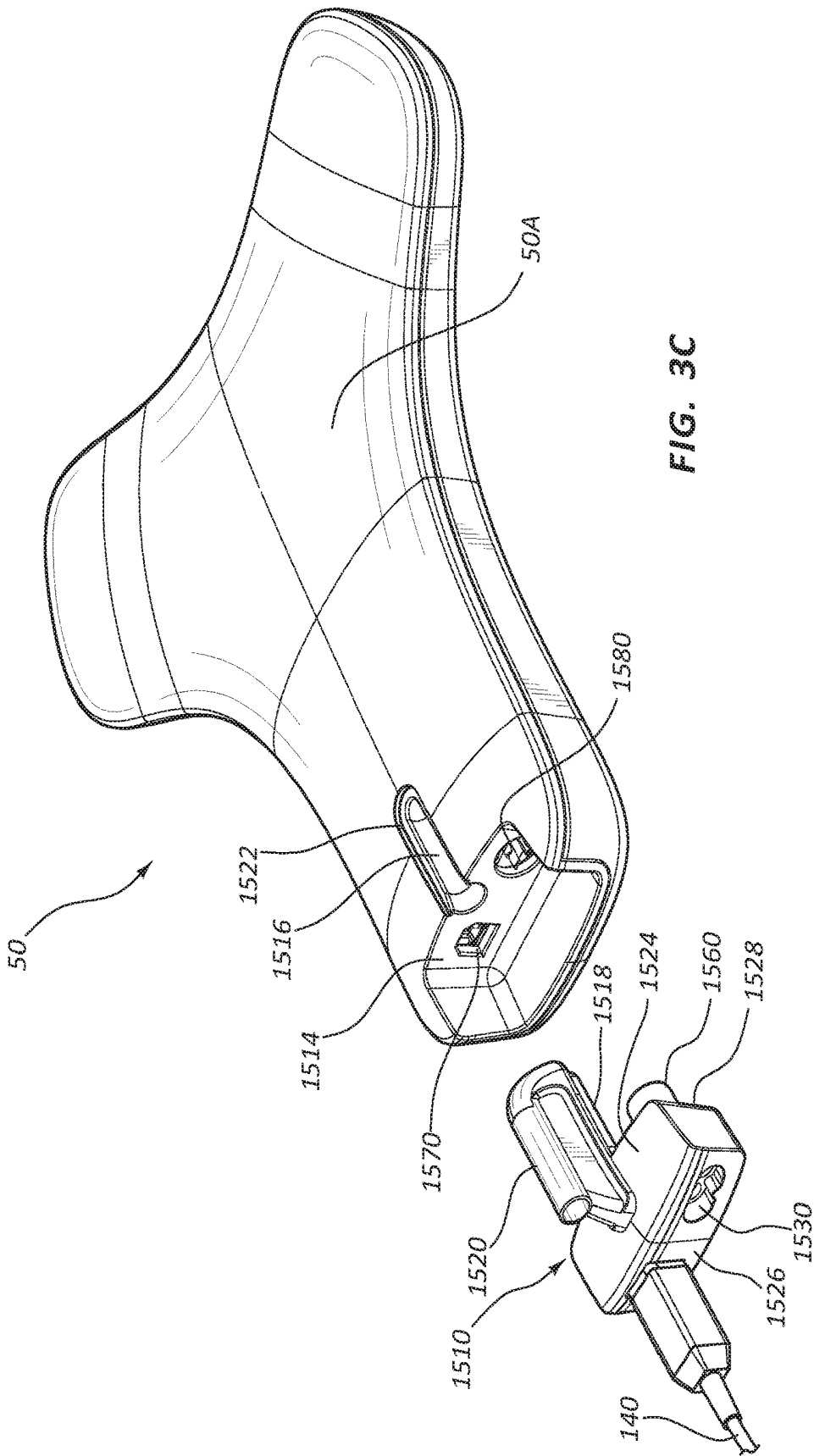

FIG. 3C

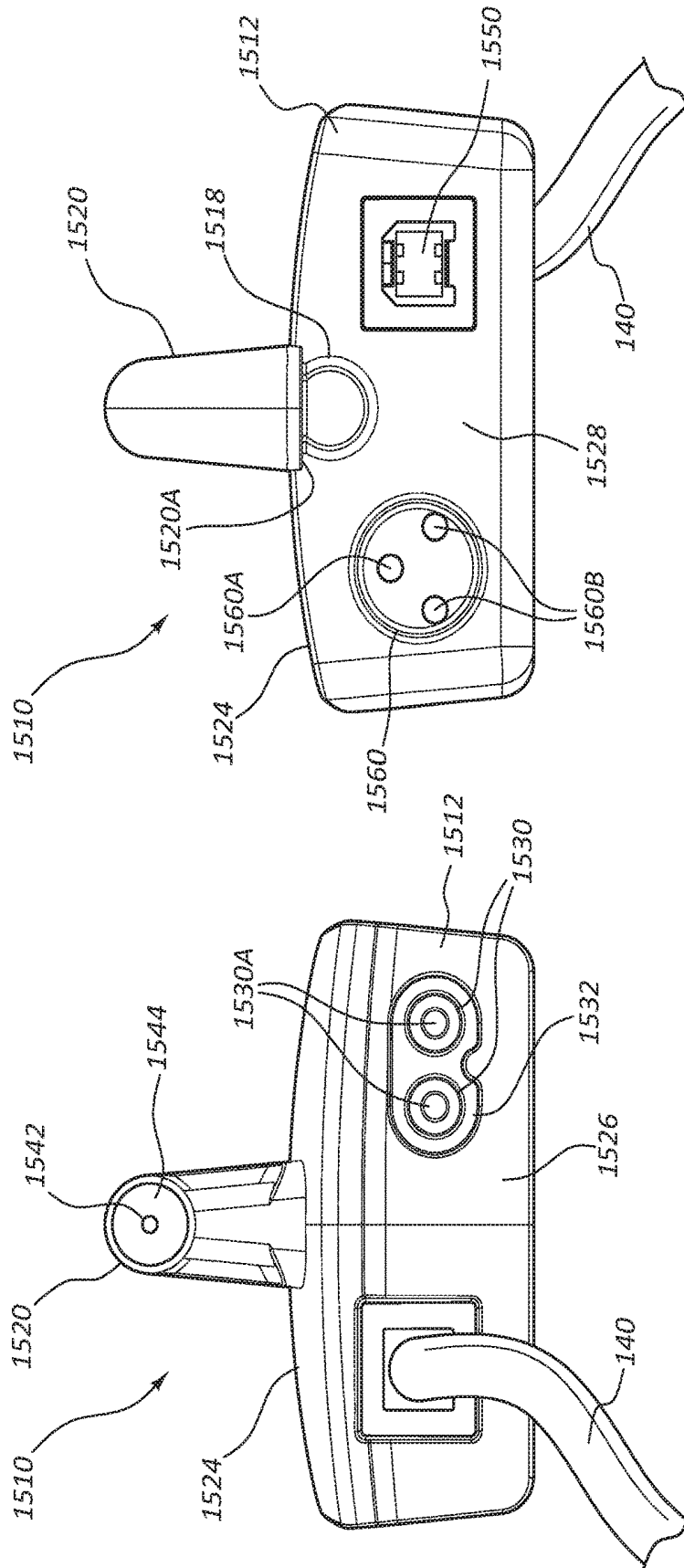

FIG. 4B

FIG. 4A

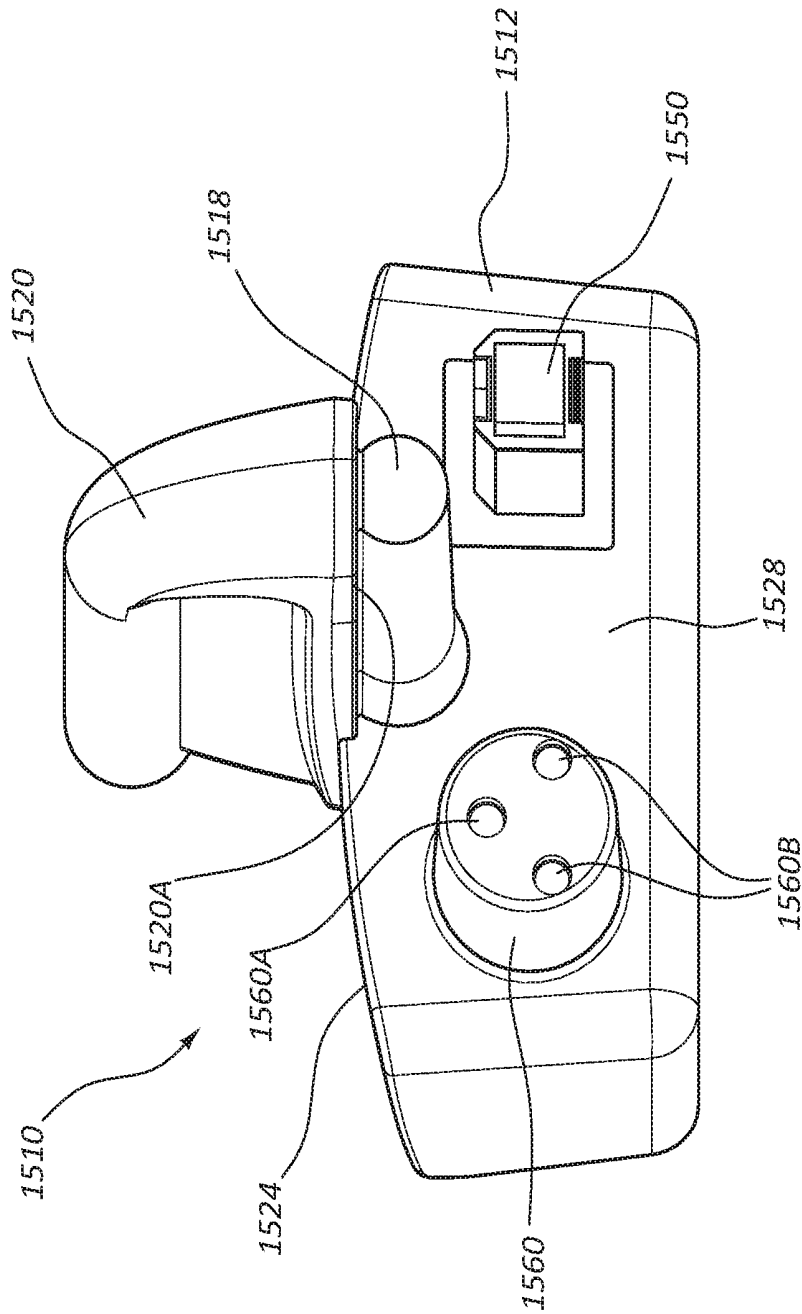

FIG. 4C

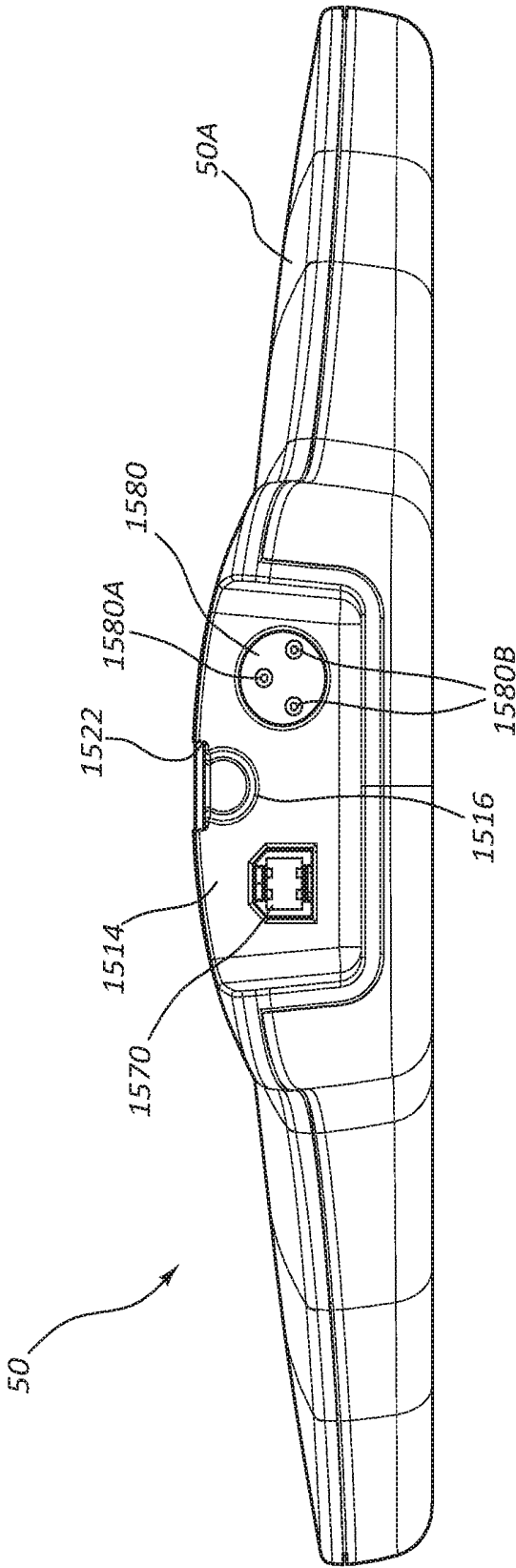

FIG. 5

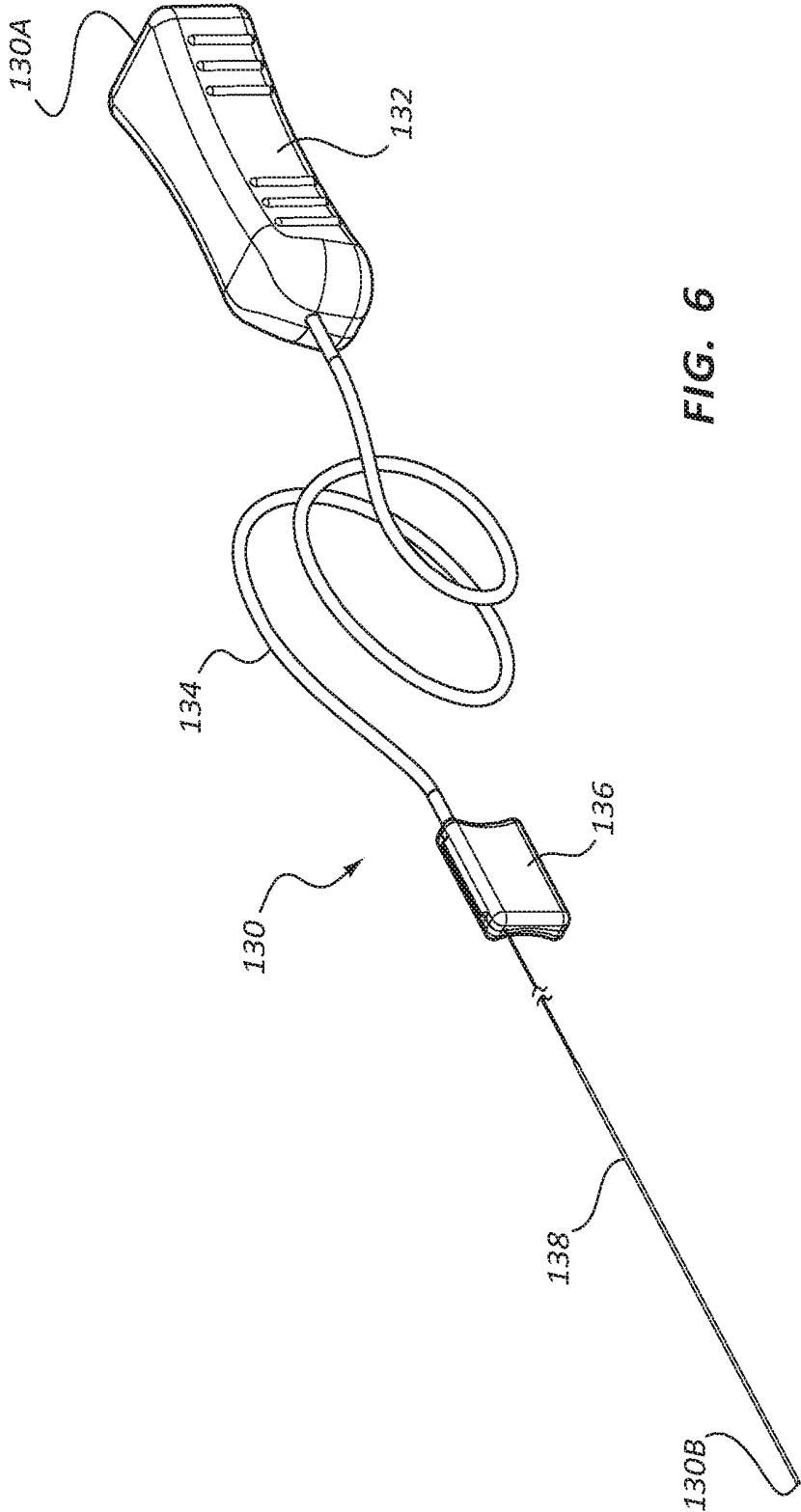

FIG. 6

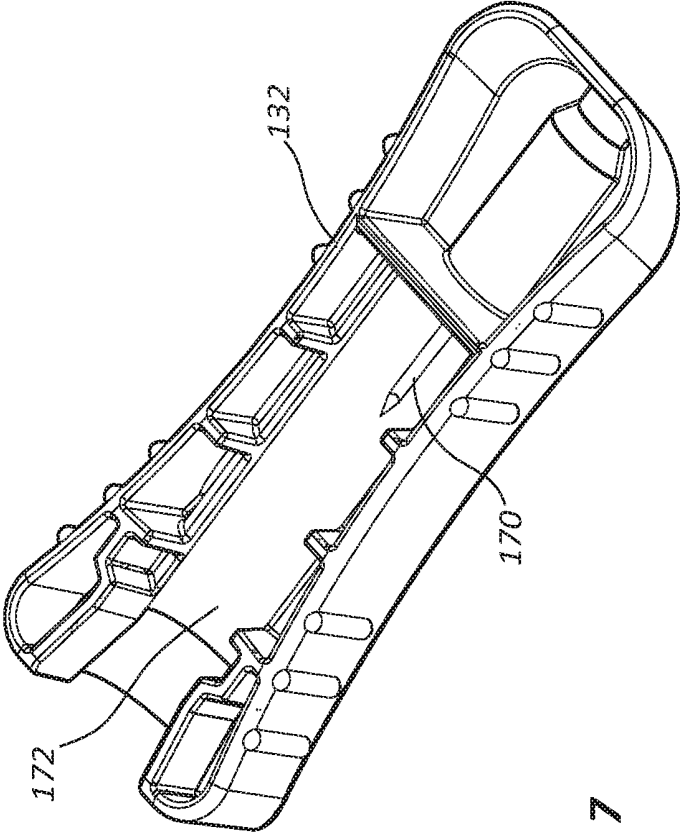
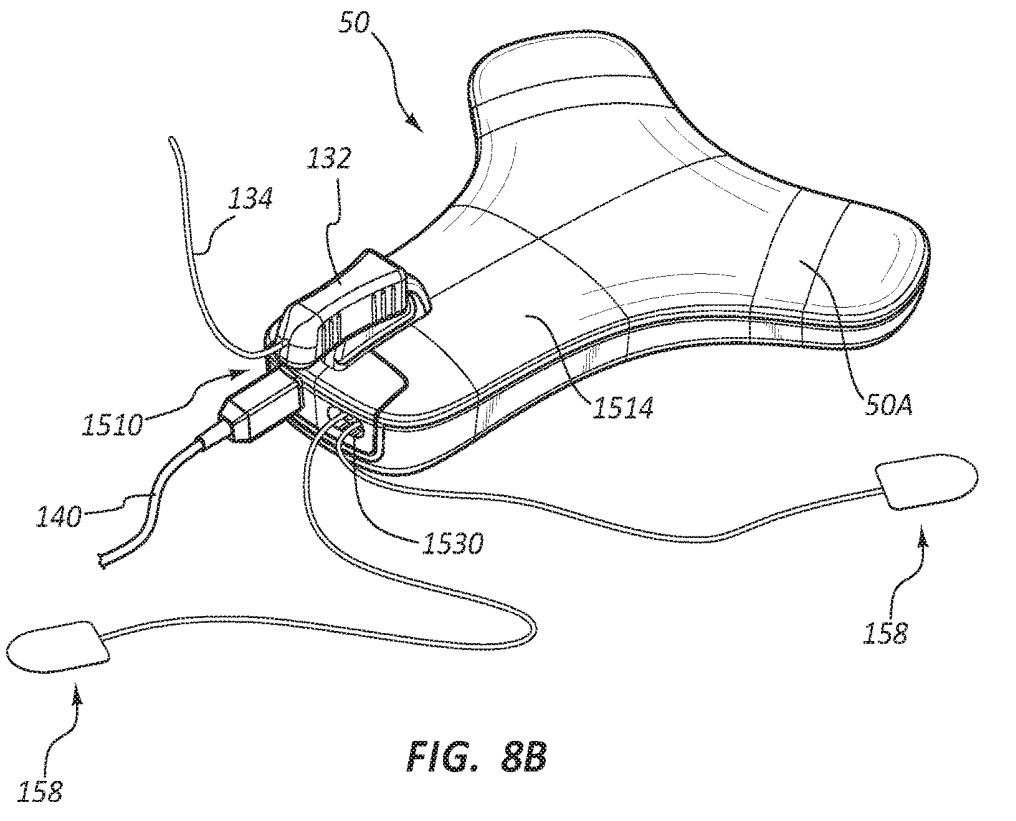
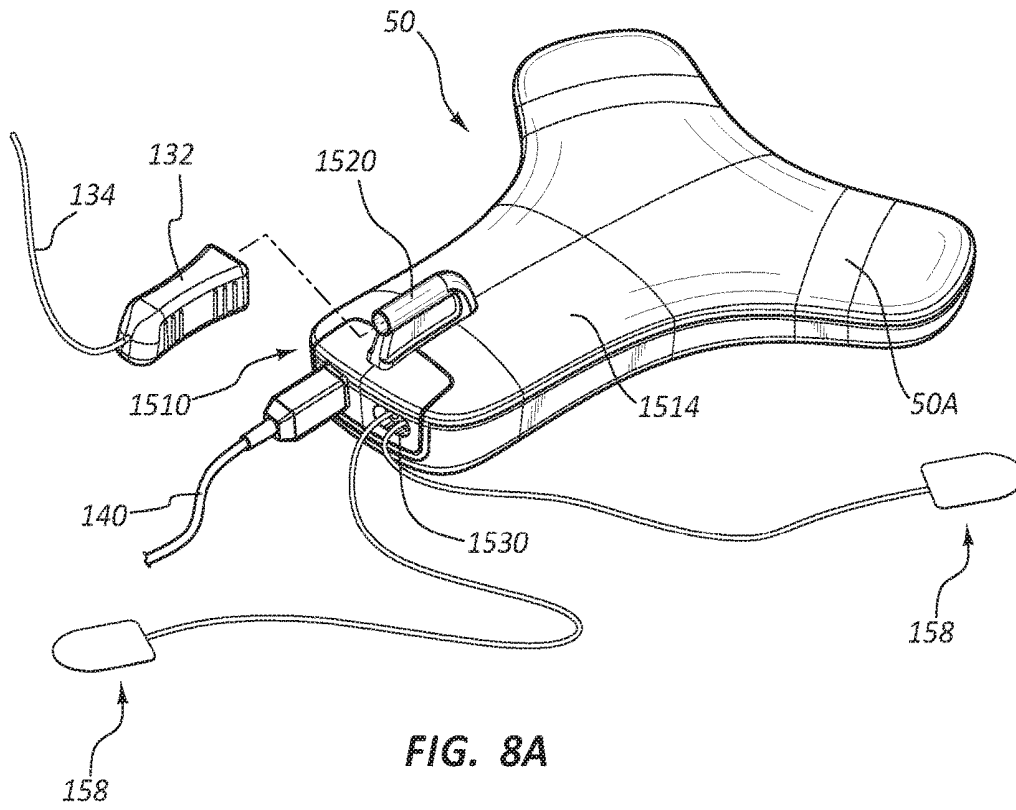

FIG. 7



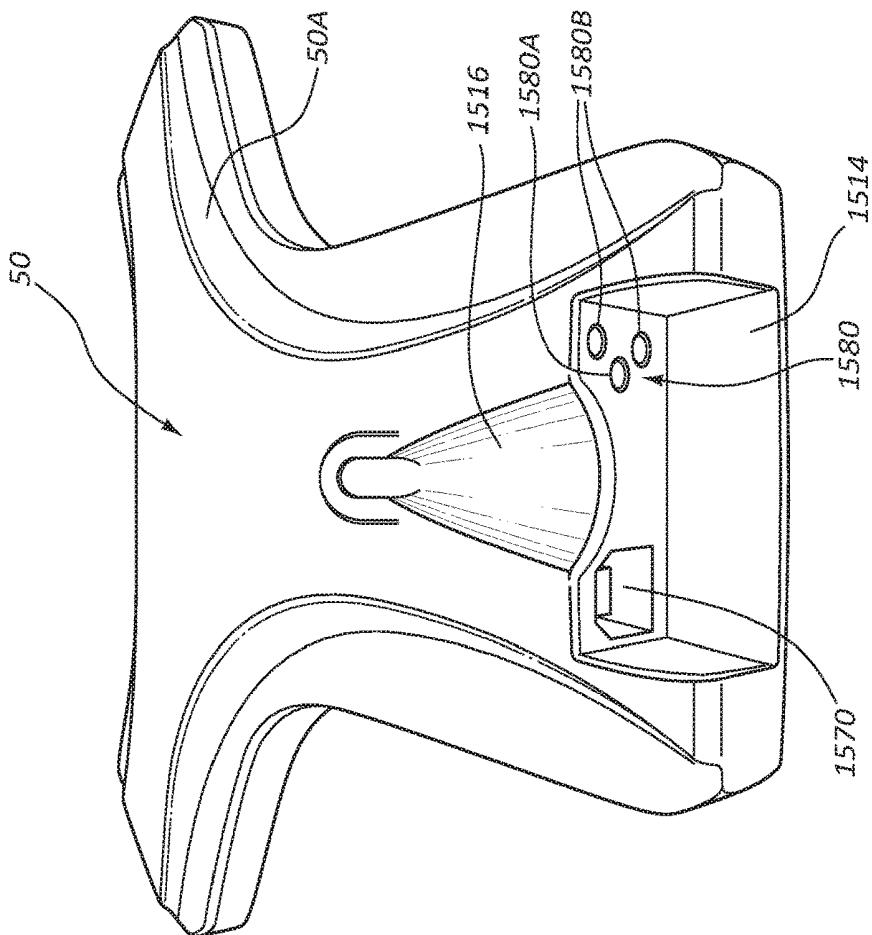

FIG. 9

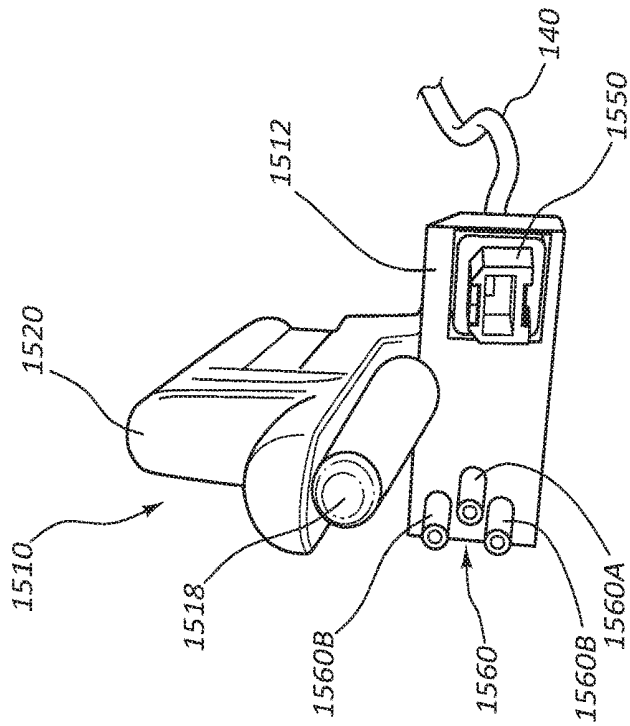

FIG. 10

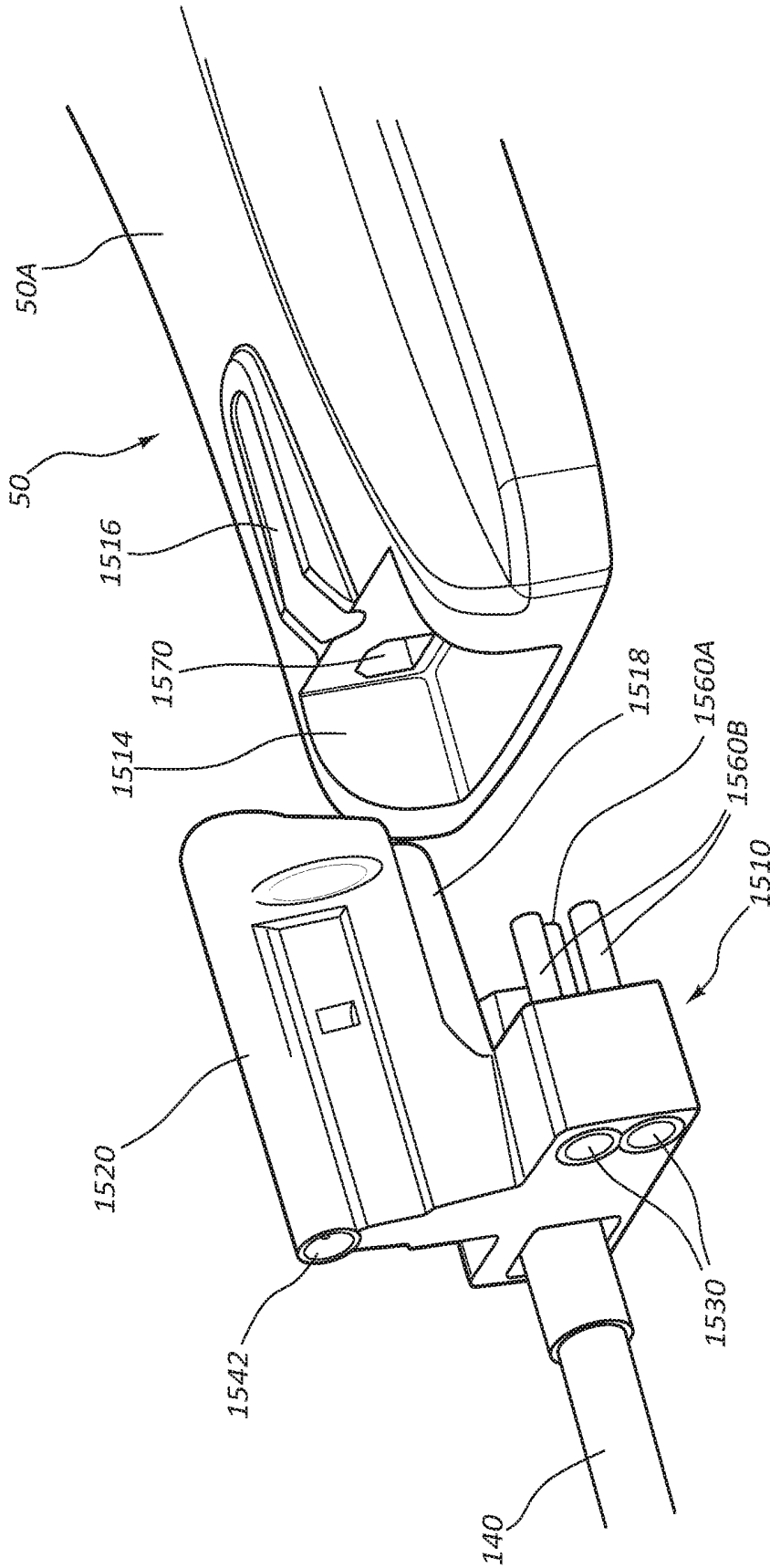

FIG. 11

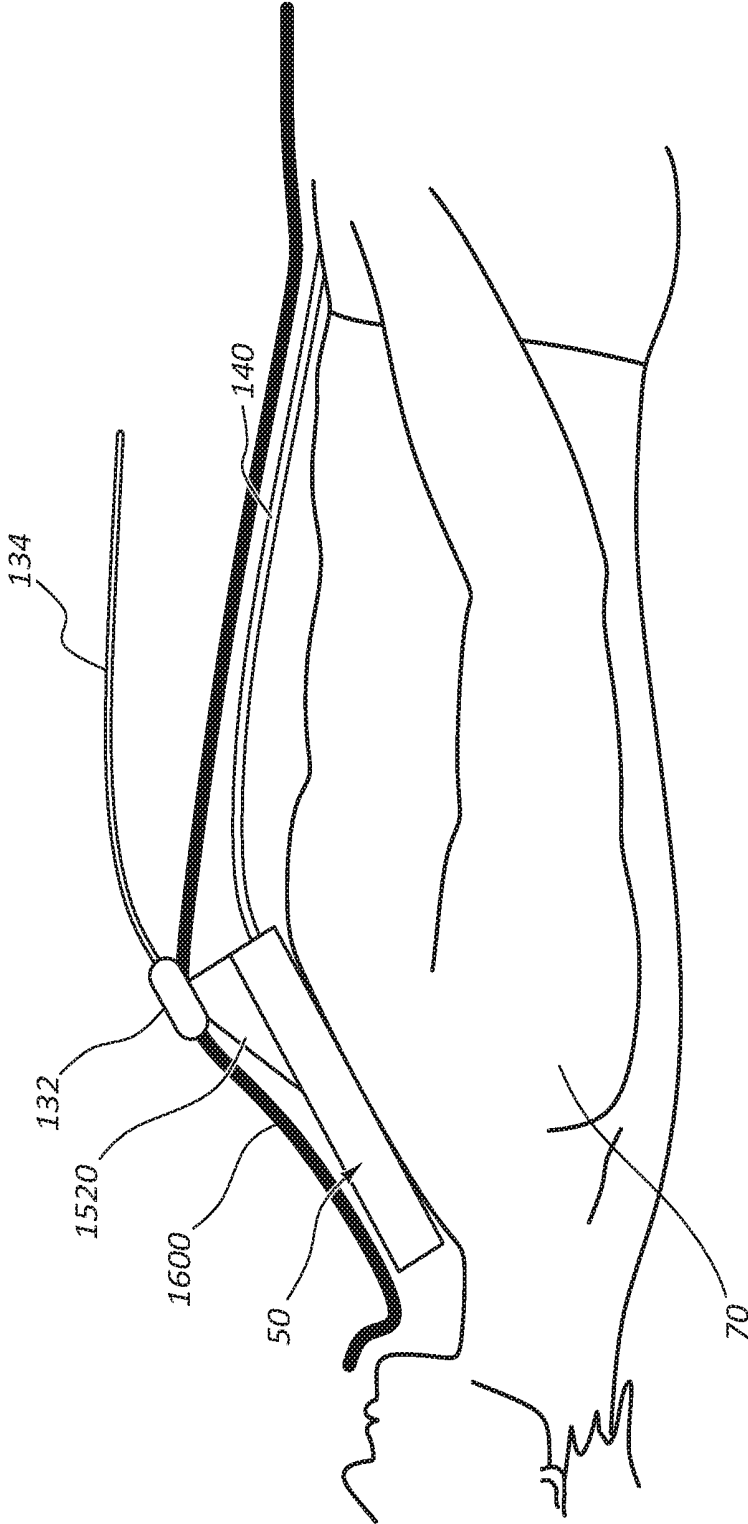

FIG. 12

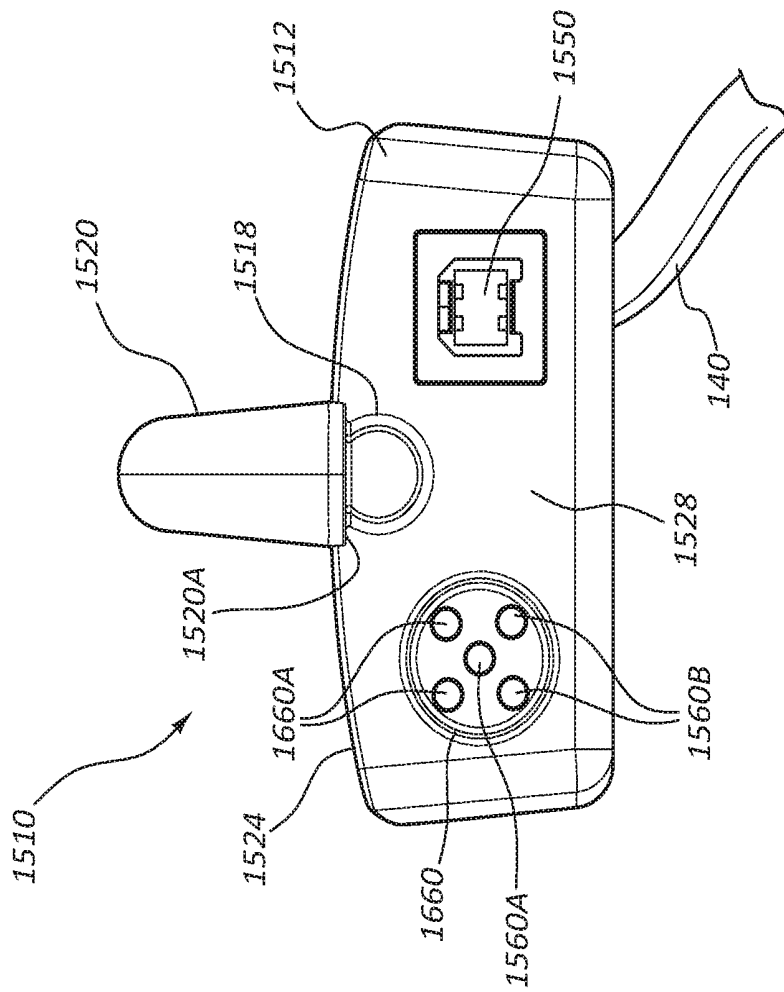

FIG. 13

1

CONNECTOR INTERFACE FOR ECG-BASED CATHETER POSITIONING SYSTEM

CROSS-REFERENCE TO RELATED APPLICATIONS

This application claims the benefit of U.S. Provisional Patent Application No. 62/185,477, filed Jun. 26, 2015, and titled "Interface Connector for ECG-based Catheter Positioning System," which is incorporated herein by reference in its entirety.

BRIEF SUMMARY

Briefly summarized, embodiments of the present invention are directed to a connector interface that is configured to enable component interconnection with a location sensor of a catheter placement system. The catheter placement system is configured to assist a clinician in positioning a catheter in a desired location within a body of a patient, such as a lower $\frac{1}{3}^{rd}$ portion of the superior vena cava within the patient's vasculature.

In one embodiment, the location sensor assembly comprises a location sensor body for temporary placement on a portion of the patient body, and a connector interface. The connector interface is configured to removably attach to the location sensor and provide a plurality of electrically conductive pathways between the location sensor and additional components of the catheter placement system to enable the additional components to operably connect with the location sensor. The connector interface further includes a first connector configured to operably connect with a second connector of one of the additional components of the catheter placement system through a sterile barrier, such as a surgical drape, interposed between the first and second connectors.

These and other features of embodiments of the present invention will become more fully apparent from the following description and appended claims, or may be learned by the practice of embodiments of the invention as set forth hereinafter.

BRIEF DESCRIPTION OF THE DRAWINGS

A more particular description of the present disclosure will be rendered by reference to specific embodiments thereof that are illustrated in the appended drawings. It is appreciated that these drawings depict only typical embodiments of the invention and are therefore not to be considered limiting of its scope. Example embodiments of the invention will be described and explained with additional specificity and detail through the use of the accompanying drawings in which:

FIG. 1 is a block diagram of a catheter placement system according to one embodiment;

FIG. 2 is a simplified view of a patient and the catheter placement system of FIG. 1;

FIGS. 3A-3C depict various views of a location sensor of the catheter placement system of FIGS. 1 and 2;

FIGS. 4A-4C depict various views of a connector interface of the location sensor or FIGS. 3A-3C;

FIG. 5 is an end view of the location sensor of FIGS. 3A-3C;

FIG. 6 is a perspective view of a stylet of the catheter placement system of FIGS. 1 and 2;

FIG. 7 is a perspective view of a tether connector of the stylet of FIG. 6;

2

FIGS. 8A and 8B depict various views of the connection of the tether connector of FIG. 6 with the location sensor of FIGS. 3A-3C;

FIG. 9 is a perspective view of a location sensor according to one embodiment;

FIG. 10 is a perspective view of a connector interface for attachment to the location sensor of FIG. 9;

FIG. 11 depicts attachment of the connector interface of FIG. 10 with the location sensor of FIG. 9;

FIG. 12 shows a side view of a patient with the location sensor of FIG. 8B placed on the patient; and

FIG. 13 is an end view of a connector interface according to one embodiment.

DETAILED DESCRIPTION OF SELECTED EMBODIMENTS

Reference will now be made to figures wherein like structures will be provided with like reference designations. It is understood that the drawings are diagrammatic and schematic representations of exemplary embodiments of the present invention, and are neither limiting nor necessarily drawn to scale.

For clarity it is to be understood that the word "proximal" refers to a direction relatively closer to a clinician using the device to be described herein, while the word "distal" refers to a direction relatively further from the clinician. For example, the end of a catheter placed within the body of a patient is considered a distal end of the catheter, while the catheter end remaining outside the body is a proximal end of the catheter. Also, the words "including," "has," and "having," as used herein, including the claims, shall have the same meaning as the word "comprising."

Embodiments of the present disclosure are generally directed to a connector interface connector for use in interconnecting various elements of a catheter placement system. Use of the present interface connector enables various components of the catheter placement system to be replaced or interchanged while enabling other components to remain. This in turn reduces system cost and allows for a modular system design.

FIGS. 1 and 2 depict various details of a catheter placement system ("system" or "placement system"), generally designated at 10, which serves as one example environment wherein embodiments of the present disclosure can be practiced. The system 10 is employed to assist a clinician in the placement of a catheter or other medical device within the body of a patient, such as within the vasculature. In one embodiment, the system 10 enables a distal tip of a catheter to be placed within the patient vasculature in desired proximity to the heart using ECG signals produced by the patient's heart. In one embodiment, the medical device includes a catheter and the intended destination of the catheter within the patient body is such that the distal tip of the catheter is disposed in the lower $\frac{1}{3}^{rd}$ portion of the superior vena cava ("SVC"). The guidance and placement system analyzes the ECG signals of the patient to determine when the catheter has reached its intended destination within the vasculature, then notifies the clinician via a display, for instance. Thus, the system includes an ECG modality for assisting in medical device placement within the patient.

In one embodiment, the above-referenced ECG guidance modality of the system 10 is accompanied by an ultrasound ("US") modality to assist with initial insertion of the medical device into the body, and a magnetic element-based tracking, or tip location system ("TLS") modality to track the

position and orientation of the medical device as it advances toward its intended destination.

As mentioned, FIGS. 1 and 2 depict various components of the system 10 in accordance with one example embodiment. As shown, the system 10 generally includes a console 20, display 30, probe 40, and sensor 50, each of which is described in further detail below.

FIG. 2 shows the general relation of these components to a patient 70 during a procedure to place a catheter 72 into the patient vasculature through a skin insertion site 73. FIG. 2 shows that the catheter 72 generally includes a proximal portion 74 that remains exterior to the patient and a distal portion 76 that resides within the patient vasculature after placement is complete. In the present embodiment, the system 10 is employed to ultimately position a distal tip 76A of the catheter 72 in a desired position within the patient vasculature. In one embodiment, the desired position for the catheter distal tip 76A is proximate the patient's heart, such as in the lower one-third ($\frac{1}{3}^{rd}$) portion of the Superior Vena Cava ("SVC"). Of course, the system 10 can be employed to place the catheter distal tip in other locations. The catheter proximal portion 74 further includes a bifurcation hub 74A that provides fluid communication between the one or more lumens of the catheter 72, one or more extension tubes 74B extending proximally from the hub, and corresponding connectors 74C for enabling connection to the catheter 72.

A processor 22, including non-volatile memory such as EEPROM for instance, is included in the console 20 for controlling system function during operation of the system 10, thus acting as a control processor. A digital controller/analog interface 24 is also included with the console 20 and is in communication with both the processor 22 and other system components to govern interfacing between the probe 40, sensor 50, and other system components.

The system 10 further includes ports 52 for connection with the sensor 50 and optional components 54 including a printer, storage media, keyboard, etc. The ports in one embodiment are USB ports, though other port types or a combination of port types can be used for this and the other interfaces connections described herein. A power connection 56 is included with the console 20 to enable operable connection to an external power supply 58. An internal battery 60 can also be employed, either with or exclusive of an external power supply. Power management circuitry 59 is included with the digital controller/analog interface 24 of the console to regulate power use and distribution.

The display 30 in the present embodiment is integrated into the console 20 and is used to display information to the clinician during the catheter placement procedure. In another embodiment, the display may be separate from the console. As will be seen, the content depicted by the display 30 changes according to which mode the catheter placement system is in: US, TLS, or in other embodiments, ECG tip confirmation. In one embodiment, a console button interface 32 and buttons included on the probe 40 can be used to immediately call up a desired mode to the display 30 by the clinician to assist in the placement procedure. In one embodiment, information from multiple modes, such as TLS and ECG, may be displayed simultaneously. Thus, the single display 30 of the system console 20 can be employed for ultrasound guidance in accessing a patient's vasculature, TLS guidance during catheter advancement through the vasculature, and (as in later embodiments) ECG-based confirmation of catheter distal tip placement with respect to a node of the patient's heart. In one embodiment, the display 30 is an LCD device.

The probe 40 is employed in connection with the first modality mentioned above, i.e., ultrasound ("US")-based visualization of a vessel, such as a vein, in preparation for insertion of the catheter 72 into the vasculature. Such visualization gives real time ultrasound guidance for introducing the catheter into the vasculature of the patient and assists in reducing complications typically associated with such introduction, including inadvertent arterial puncture, hematoma, pneumothorax, etc.

As such, in one embodiment a clinician employs the first, US, modality to determine a suitable insertion site and establish vascular access, such as with a needle and introducer, then with the catheter. The clinician can then seamlessly switch, via button pushes on the probe button pad, to the second, TLS, modality without having to reach out of the sterile field. The TLS mode can then be used to assist in advancement of the catheter 72 through the vasculature toward an intended destination.

FIG. 1 shows that the probe 40 further includes button and memory controller 42 for governing button and probe operation. The button and memory controller 42 can include non-volatile memory, such as EEPROM, in one embodiment. The button and memory controller 42 is in operable communication with a probe interface 44 of the console 20, which includes a piezo input/output component 44A for interfacing with the probe piezoelectric array and a button and memory input/output component 44B for interfacing with the button and memory controller 42.

Note that while a vein is typically depicted on the display 30 during use of the system 10 in the US modality, other body lumens or portions can be imaged in other embodiments. Note that the US mode can be simultaneously depicted on the display 30 with other modes, such as the TLS mode or ECG mode, if desired. In addition to the visual display 30, aural information, such as beeps, tones, etc., or vibratory/motion-based cues can also be employed by the system 10 to assist the clinician during catheter placement. Moreover, the buttons included on the probe 40 and the console button interface 32 can be configured in a variety of ways, including the use of user input controls in addition to buttons, such as slide switches, toggle switches, electronic or touch-sensitive pads, etc. Additionally, US, TLS, and ECG activities can occur simultaneously or exclusively during use of the system 10.

As just described, the handheld ultrasound probe 40 is employed as part of the integrated catheter placement system 10 to enable US visualization of the peripheral vasculature of a patient in preparation for transcutaneous introduction of the catheter. In the present example embodiment, however, the probe is also employed to control functionality of the TLS portion, or second modality, of the system 10 when navigating the catheter toward its desired destination within the vasculature as described below. Again, as the probe 40 is used within the sterile field of the patient, this feature enables TLS functionality to be controlled entirely from within the sterile field. Thus the probe 40 is a dual-purpose device, enabling convenient control of both US and TLS functionality of the system 10 from the sterile field. In one embodiment, the probe can also be employed to control some or all ECG-related functionality, or third modality, of the catheter placement system 10, as described further below.

The catheter placement system 10 further includes the second modality mentioned above, i.e., the magnetically-based catheter TLS, or tip location system. The TLS enables the clinician to quickly locate and confirm the position and/or orientation of the catheter 72, such as a peripherally-

inserted central catheter (“PICC”), central venous catheter (“CVC”), or other suitable catheter or medical device, during initial placement into and advancement through the vasculature of the patient 70. Specifically, the TLS modality detects a magnetic field generated by a magnetic element-equipped tip location stylet, which is pre-loaded in one embodiment into a longitudinally defined lumen of the catheter 72, thus enabling the clinician to ascertain the general location and orientation of the catheter tip within the patient body. In one embodiment, the magnetic assembly can be tracked using the teachings of one or more of the following U.S. Pat. Nos. 5,775,322; 5,879,297; 6,129,668; 6,216,028; and 6,263,230. The contents of the afore-mentioned U.S. patents are incorporated herein by reference in their entireties. The TLS also displays the direction in which the catheter tip is pointing, thus further assisting accurate catheter placement. The TLS further assists the clinician in determining when a malposition of the catheter tip has occurred, such as in the case where the tip has deviated from a desired venous path into another vein.

As mentioned, the TLS utilizes a stylet 130 to enable the distal end of the catheter 72 to be tracked during its advancement through the vasculature. In one embodiment and as shown in FIG. 6, the stylet 130 includes a proximal end 130A and a distal end 130B, with an included handle 136. A core wire 138 distally extends from the handle 136, and a tether 134 (for operably connecting the stylet 130 to the placement system 10) extends proximally from the handle. A magnetic assembly is disposed distally of the core wire 138. The magnetic assembly includes one or more magnetic elements disposed adjacent one another proximate the stylet distal end 130B and encapsulated by tubing. In the present embodiment, a plurality of magnetic elements is included, each element including a solid, cylindrically shaped ferromagnetic stacked end-to-end with the other magnetic elements. An adhesive tip can fill the distal tip of the tubing, distally to the magnetic elements.

Note that in other embodiments, the magnetic elements may vary from the design in not only shape, but also composition, number, size, magnetic type, and position in the stylet distal segment. For example, in one embodiment, the plurality of ferromagnetic magnetic elements is replaced with an electromagnet assembly, such as an electromagnetic coil, which produces a magnetic field for detection by the sensor. Another example of an assembly usable here can be found in U.S. Pat. No. 5,099,845, entitled “Medical Instrument Location Means,” which is incorporated herein by reference in its entirety. Yet other examples of stylets including magnetic elements that can be employed with the TLS modality can be found in U.S. Pat. No. 8,784,336, entitled “Stylet Apparatuses and Methods of Manufacture,” which is incorporated herein by reference in its entirety. These and other variations are therefore contemplated by embodiments of the present invention. It should be appreciated herein that “stylet” as used herein can include any one of a variety of devices configured for removable placement within a lumen of the catheter to assist in placing a distal end of the catheter in a desired location within the patient’s vasculature. In one embodiment, the stylet includes a guide-wire. As such, it is appreciated that stylets of other forms and configurations can also be acceptably used, in accordance with the present disclosure.

FIG. 2 shows disposal of the stylet 130 substantially within a lumen in the catheter 72 such that the proximal portion thereof extends proximally from the catheter lumen, through the bifurcation hub 74A and out through a selected one of the extension tubes 74B. So disposed within a lumen

of the catheter, the distal end 130B of the stylet 130 in the present embodiment is substantially co-terminal with the distal catheter end 76A such that detection by the TLS of the stylet distal end correspondingly indicates the location of the catheter distal end. In other embodiments, other positional relationships between the distal ends of the stylet and catheter or medical device are possible.

The TLS sensor 50 (also referred to herein as a “location sensor”) is employed by the system 10 during TLS operation to detect the magnetic field produced by the magnetic elements of the stylet 130. As seen in FIG. 2, the TLS sensor 50 is placed on the chest of the patient during catheter insertion. The TLS sensor 50 is positioned on the chest of the patient in a predetermined location, such as through the use of external body landmarks, to enable the magnetic field of the stylet magnetic elements, disposed in the catheter 72 as described above, to be detected during catheter transit through the patient vasculature. Again, as the magnetic elements of the stylet magnetic assembly are co-terminal with the distal end 76A of the catheter 72 in one embodiment (FIG. 2), detection by the TLS sensor 50 of the magnetic field of the magnetic elements provides information to the clinician as to the position and orientation of the catheter distal end during its transit.

In greater detail, the TLS sensor 50 is operably connected to the console 20 of the system 10 via a connection of a console cable 140 with one or more of the ports 52 of the console, as shown in FIG. 1. The console cable 140 attaches to the TLS sensor 50 in a manner to be described further below. Note that other connection schemes between the TLS sensor and the system console can also be used, without limitation. As just described, the magnetic elements are employed in the stylet 130 to enable the position of the catheter distal end 76A (FIG. 2) to be observable relative to the TLS sensor 50 placed on the patient’s chest. Detection by the TLS sensor 50 of the stylet magnetic elements is graphically displayed on the display 30 of the console 20 during TLS mode. In this way, a clinician placing the catheter is able to generally determine the location of the catheter distal end 76A within the patient vasculature relative to the TLS sensor 50 and detect when catheter malposition, such as advancement of the catheter along an undesired vein, is occurring.

As discussed above, the system 10 includes additional functionality in the present embodiment wherein determination of the proximity of the catheter distal tip 76A relative to a sino-atrial (“SA”) or other electrical impulse-emitting node of the heart of the patient 70 can be determined, thus providing enhanced ability to accurately place the catheter distal tip in a desired location proximate the node. Also referred to herein as “ECG” or “ECG-based tip confirmation,” this third modality of the system 10 enables detection of ECG signals from the SA node in order to place the catheter distal tip in a desired location within the patient vasculature. Note that the US, TLS, and ECG modalities are seamlessly combined in the present system 10, but can be employed in concert or individually to assist in catheter placement. In one embodiment, it is understood that the ECG modality as described herein can be included in a stand-alone system without the inclusion of the US and TLS modalities. Thus, the environments in which the embodiments herein are described are understood as merely example environments and are not considered limiting of the present disclosure.

As described, the catheter stylet 130 is removably pre-disposed within the lumen of the catheter 72 being inserted into the patient 70 via the insertion site 73. The stylet 130,

in addition to including a magnetic assembly for the magnetically-based TLS modality, includes a sensing component, i.e., an internal, intravascular ECG sensor assembly, proximate its distal end and including a portion that is co-terminal with the distal end of the catheter tip for intravascularly sensing ECG signals produced by the SA node, in the present embodiment when the catheter 72 and accompanying stylet 130 are disposed within the patient vasculature. The intravascular ECG sensor assembly is also referred to herein as an internal or “intravascular ECG sensor component,” and the stylet 130 as an “ECG stylet.”

As mentioned, the stylet 130 includes the tether 134 extending from its proximal end 130A that operably connects to the TLS sensor 50 in a manner to be described below, though other connection schemes to the system 10 are contemplated. As will be described in further detail, the stylet tether 134 permits ECG signals detected by the ECG sensor assembly included on a distal portion of the stylet 130 to be conveyed to the TLS sensor 50 during confirmation of the catheter tip location as part of the ECG signal-based tip confirmation modality.

External reference and ground ECG electrodes 158 attach to the body of the patient 70 in the present embodiment and are operably attached to the TLS sensor 50 to provide an external baseline ECG signal to the system 10 and to enable the system to filter out high level electrical activity unrelated to the electrical activity of the SA node of the heart, thus enabling the ECG-based tip confirmation functionality. As shown, in the present embodiment, one external electrode 158 is placed on the patient skin proximate the upper right shoulder (“right arm” placement) while another external electrode is placed proximate the lower left abdomen (“left leg” placement). This electrode arrangement provides a lead II configuration according to Einthoven’s triangle of electrocardiography. Operable attachment of the external electrodes 158 with the sensor 50 in a manner to be described below enables the ECG signals detected by the external electrodes to be conveyed to the console 20 of the system 10 or to another suitable destination. As such, the external electrodes 158 serve as one example of an external ECG sensor component. Other external sensors for detecting a baseline ECG signal external to the patient body can also be employed in other embodiments. In addition, other electrode locations are also possible.

Together with the external ECG signal received from the external ECG sensor component (i.e., the external ECG electrodes 158 placed on the patient’s skin), an internal, intravascular ECG signal sensed by the internal ECG sensor component (i.e., the stylet ECG sensor assembly of the stylet 130), is received by the TLS sensor 50 positioned on the patient’s chest (FIG. 10) or other designated component of the system 10. The TLS sensor 50 and/or console processor 22 can process the external and internal ECG signal data to produce one or more electrocardiogram traces, including a series of discrete ECG complexes, on the display 30, as will be described. In the case where the TLS sensor 50 processes the external and internal ECG signal data, a processor is included therein to perform the intended functionality. If the console 20 processes the ECG signal data, the processor 22, controller 24, or other processor can be utilized in the console to process the data.

Thus, as it is advanced through the patient vasculature, the catheter 72 equipped with the stylet 130 as described above can advance under the TLS sensor 50, which is positioned on the chest of the patient as shown in FIG. 10. This enables the TLS sensor 50 to detect the position of the magnetic assembly of the stylet 130 (described further above), which

is substantially co-terminal with the distal tip 76A of the catheter as located within the patient’s vasculature. The detection by the TLS sensor 50 of the stylet magnetic assembly is depicted on the display 30 during ECG mode.

The display 30 can further depict during ECG mode one or more ECG electrocardiogram traces produced as a result of patient heart’s electrical activity as detected by the external and internal ECG sensor components described above. In greater detail, the ECG electrical activity of the SA node, including the P-wave of the trace, is detected by the external and internal sensor components and forwarded to the TLS sensor 50 and console 20. The ECG electrical activity is then processed for depiction on the display 30, as will be described further below.

A clinician placing the catheter can then observe the ECG data, which assists in determining optimum placement of the distal tip 76A of the catheter 72, such as proximate the SA node, for instance. In one embodiment, the console 20 includes the electronic components, such as the processor 22 (FIG. 1), necessary to receive and process the signals detected by the external and internal sensor components. In another embodiment, the TLS sensor 50 can include the necessary electronic components processing the ECG signals.

As already discussed, the display 30 is used to display information to the clinician during the catheter placement procedure. The content of the display 30 changes according to which mode the catheter placement system is in: US, TLS, or ECG. Any of the three modes can be immediately called up to the display 30 by the clinician, and in some cases information from multiple modes, such as TLS and ECG, may be displayed simultaneously. In one embodiment, as before, the mode the system is in may be controlled by the control buttons included on the handheld probe 40, thus eliminating the need for the clinician to reach out of the sterile field (such as touching the button interface 32 of the console 20) to change modes. Thus, in the present embodiment the probe 40 is employed to also control some or all ECG-related functionality of the system 10. Note that the button interface 32 or other input configurations can also be used to control system functionality. Also, in addition to the visual display 30, aural information, such as beeps, tones, etc., can also be employed by the system to assist the clinician during catheter placement.

Note that further details regarding the system 10 can be found in U.S. Pat. No. 8,848,382, issued Sep. 30, 2014, and entitled “Apparatus and Display Methods Relating to Intravascular Placement of a Catheter,” which is incorporated herein by reference in its entirety. It is further noted that the above-described catheter placement system is but example of a variety of placement systems that can benefit from the principles of the embodiments described herein.

In view of the above discussion, reference is now made to FIGS. 3A-3C, which depict various details of the above-described TLS sensor 50, also referred to herein as a “location sensor.” In particular, the location sensor 50 includes a connector interface (“interface”) 1510 that is configured according to one embodiment. The interface 1510 is configured to enable interconnection of the location sensor 50 with various other catheter placement system components, including the ECG signal-sensing stylet 130 via the tether 134 (FIG. 6), the external ECG electrodes 158 (FIG. 2) via their respective lead wires (“leads”), and the console cable 140 that operably connects the location sensor with the console 20 of the system 10.

As shown, the interface 1510 includes a body 1512 that is configured to removably connect to the location sensor 50

within a pocket **1514** defined on a lower portion of the location sensor **50**, from the perspective shown in FIG. 3A. The interface body **1512** includes a rail **1518** defined on a fin **1520** that is configured to be slidably received within a corresponding track **1516** defined on an outer surface **50A** of the location sensor **50** proximate the pocket **1514**, as shown in FIG. 3C. Other connective schemes can be employed in other embodiments. Also, the particular size, shape, and configuration of the interface **1510** can vary. A bottom portion **1520A** of the fin **1520** is configured to be slidably received within a track perimeter **1522** defined about the track **1516** in order to secure the connection between the location sensor **50** and the interface **1510**.

The interface body **1512** defines an outer surface **1524** that is shaped and configured so as to match the outer surface **50A** of the location sensor **50** when the interface **1510** is attached to the location sensor. Of course, the particular shape and configuration of both the location sensor and the interface can vary from what is shown and described. Also, the particular connection point of the interface with the location sensor can vary. The interface body **1512** further defines an end surface **1528** that remains externally accessible when the interface **1510** is operably attached to the location sensor (FIGS. 3A, 3B), as well as an inner surface **1528** (FIGS. 3C, 4B, 4C) that is inaccessible when the interface is attached to the location sensor. As will be described, various connection points are included on both the end surface **1526** and the inner surface **1528** to enable various components of the catheter placement system **10** to operably connect with the location sensor **50**. The size, shape, type, and number of connection points can vary from the below discussion.

FIGS. 4A-4C depict further details regarding the interface **1510**. As shown, the end surface **1526** includes various connection points for enabling interconnection with components of the catheter placement system **10**. Specifically, the end surface **1526** includes a pair of ECG lead connector receptacles **1530** disposed in a recess **1532**. The ECG lead connector receptacles **1530** each include a female contact **1530A** sized and configured to receive therein a male connector end of the leads of the ECG electrodes **158**. In the present embodiment, the recess **1532** is shaped so as to receive a dual connector that includes both male connector ends of the ECG electrodes **158** in a single plug, though other configurations are also possible for the ECG lead connection scheme.

FIG. 4A shows that the fin **1520** includes an ECG stylet wire receptacle **1542**, surrounded by a centering cone **1544**, for removably receiving therein a pin contact **170** (FIG. 7) of a tether connector **132** of the ECG stylet **130** (FIG. 6). Further details regarding connection of the ECG stylet **130** to the interface **1510** and the location sensor **50** are given further below.

FIG. 4A further shows that the console cable **140** is permanently attached so as to extend from the interface **1510**, as shown. The length of the console cable **140** can vary according to need, but is sufficient in the present embodiment to extend between the location sensor **50** and the console **20**, as shown in FIG. 2.

The inner surface **1528** of the interface **1510** includes various connection points for enabling interconnection of the aforementioned components with the location sensor. As shown, in FIGS. 4B and 4C, a USB type B plug **1550** of the console cable **140** extends from the interface inner surface **1528** to operably connect with a corresponding USB type B receptacle **1570** (FIG. 5) disposed in the pocket **1514** when the interface **1510** mates with the location sensor **50**. Simi-

larly, a rounded, cylindrical ECG plug **1560** extends from the interface inner surface **1528** to operably connect with a corresponding, cylindrically shaped ECG receptacle **1580** defined in the pocket **1514** when the interface **1510** mates with the location sensor **50**.

Specifically, the ECG plug **1560** includes an ECG stylet wire contact **1560A** that is operably connected with the ECG stylet wire receptacle **1542** on the fin **1520**, as well as two ECG lead contacts **1560B** that are operably connected with the ECG lead electrical contacts **1530A** in the ECG lead receptacle **1530** included on the interface end surface **1526**. In the present embodiment, the ECG lead contacts **1560B** are integrally formed with the ECG lead contacts **1530A** and are formed as sleeves so as to receive corresponding ECG lead pins **1580B** disposed in the ECG receptacle **1580**. The ECG receptacle **1580** further includes an ECG stylet pin **1580A** for operably connecting with the sleeve-type ECG stylet wire contact **1560A** of the ECG plug **1560**. FIGS. 3A, 8A, and 8B show the manner of attachment of the interface **1510** within the pocket **1514** of the location sensor **50**.

FIGS. 6 and 7 show details of the ECG stylet **130**, including the pin contact **170** included in a channel **172** of the tether connector **132**, as described further above. As shown in FIGS. 8A and 8B, the tether connector **132** is slid over the fin **1520** in a snug friction fit such that the pin contact **170** is received within the ECG stylet wire receptacle **1542**. The ECG stylet wire receptacle **1542** is operably connected within the interface body **1512** with the ECG stylet wire contact **1560A**. Thus, this connection establishes an electrically conductive pathway from the ECG stylet **130** to the location sensor **50** via the operable connections of the pin contact **170** with the ECG stylet wire receptacle **1542**, and the ECG stylet wire contact **1560A** (FIG. 4C) of the interface **1510** with the ECG stylet wire pin **1580A** (FIG. 5) of the location sensor. This, in turn, enables ECG signals detected by the ECG stylet **130** to be conveyed to the location sensor **50** and, in one embodiment, the console **20** for processing by the system **10**.

Correspondingly, FIG. 8B shows the connector ends of the leads of the ECG external electrodes **158** received within the ECG lead connector receptacles **1530** of the interface **1510** such that they each operably connect with a corresponding one of the electrical contacts **1530A** therewithin. Thus, conductive pathways are established from the ECG external electrodes **158** to the location sensor via the operable connections of the connector ends of the ECG external electrode leads with ECG lead connector receptacles **1530**, and the ECG lead contacts **1560B** (FIG. 4C) of the interface **1510** with the ECG lead pins **1580B** (FIG. 5) of the location sensor.

Also, conductive pathways are established from the location sensor **50** to the console **20** (FIGS. 1, 2) via the operable connection of the console cable **140**, namely, the operable connection of its male connector **1550** of the interface **1510** (FIG. 4C) with the receptacle **1570** of the location sensor (FIG. 5). Note that while shown as a USB-type cable, the console cable can include other styles, types, form factors, etc.

In the above-described configurations, therefore, the location sensor and attached components are ready for use by the catheter placement system **10**, in one embodiment. Indeed, FIG. 12 shows the manner of use of the location sensor **50** when connected with the various components described above during a catheter insertion procedure using the catheter placement system **10**. Note that the tether connector **132** is configured to pierce a sterile drape **1600** (which is placed over the patient during catheter insertion procedures) such

that regions above the drape are considered a sterile environment, while the location sensor **50**, the fin **1520**, and the console cable **140** are not considered sterile. The manner in which the tether connector **132** is able to pierce the drape **1600** and operably connect with the location sensor **50** enables such a connection without compromising the sterility of the sterile field.

Note that the various connecting components described with the above electrically conductive connections can vary in size, type, number, etc., from what is discussed herein. Note further that in the present embodiment attachment of the interface **1510** with the location sensor **50** is maintained via the friction fit of the various electrical connections between the interface and the location sensor, as just discussed above. In another embodiment, additional features can be included on one or both of the interface body **1512** and the location sensor **50** to provide a friction fit or other type of securement to maintain attachment between the interface and the location sensor.

FIGS. **9-11** depict the interface **1510** according to another embodiment, wherein the ECG stylet wire contact **1560A** and the two ECG lead contacts **1560B** discretely extend from interface body **1512** instead of being included in a male plug (FIG. **10**). Correspondingly, the ECG stylet wire pin **1580A** and the two ECG lead pins **1580B** of the location sensor **50** are discretely positioned instead of grouped within a receptacle in the location sensor pocket **1514** (FIG. **9**). Also, note that the shape and configuration of the track **1516** of the location sensor **50** (FIG. **9**) differs from that of the previous embodiment. These and other modifications are therefore contemplated.

FIG. **13** shows an interface connector configuration according to another embodiment, wherein a connector block **1660** includes not only the ECG stylet wire contact **1560A** and the ECG lead contacts **1560B**, but also two electromagnetic contacts **1660A** for providing power to an electromagnet element disposed in the ECG stylet **130** to be used when the system **10** is in TLS mode, described above. The particular arrangement and configuration of the various connectors can vary from what is shown here.

It is noted that the interface **1510** in one embodiment is reusable for multiple catheter insertion procedures, but is easily removable and replaceable should the need arise, such as in cases where damage to the wires or cables of the catheter insertion system **10** have been damaged due to use, accident, or repeated cleaning cycles. This, in turn enables replacement without the need to replace the entire location sensor, which can involve considerably more cost. Further, it is appreciated that the ECG stylet **130** and the external ECG electrodes and their leads are disposable and are disposed of after a single catheter insertion is complete. The console cable in one embodiment is permanently attached with the interface **1510** and thus is reusable. Also, though described here as employed with a location sensor, the interface in other embodiments can be employed to operably connect with other types of medical devices where interconnections as are enabled by the interface as described herein are needed. Further, note that various types of electrical connectors can be used to operably connect the various components described herein, including circuit board-edge connectors, peg and cuff-type connectors, type-C and other types of USB connectors, spring-loaded pins for pressing against conductive pads, etc. These and other connectors are therefore contemplated.

Embodiments of the invention may be embodied in other specific forms without departing from the spirit of the present disclosure. The described embodiments are to be

considered in all respects only as illustrative, not restrictive. The scope of the embodiments is, therefore, indicated by the appended claims rather than by the foregoing description. All changes that come within the meaning and range of equivalency of the claims are to be embraced within their scope.

What is claimed is:

1. A location sensor assembly for use with a catheter placement system, comprising:

a location sensor body, including:

a console port;
an electrocardiogram (ECG) port; and
a stylet connector recess; and

a removable connector interface including:

a console connection interface designed for mating with the console port;
an electrocardiogram (ECG) connection interface designed for mating with the ECG port; and
a stylet connection interface designed for mating with the stylet connector recess,

wherein the removable connector interface enables simultaneous mating upon attachment to the location sensor body.

2. The location sensor assembly as defined in claim **1**, further comprising at least one of an ECG stylet configured to be removably disposed within a lumen of a catheter, an ECG external electrode, and a console of the catheter placement system.

3. The location sensor assembly as defined in claim **2**, wherein the stylet connection interface is configured to receive a stylet connector included with the ECG stylet.

4. The location sensor assembly as defined in claim **3**, wherein the stylet connector of the ECG stylet is a male pin connector.

5. The location sensor assembly as defined in claim **4**, wherein the stylet connection interface comprises a fin portion.

6. The location sensor assembly as defined in claim **5**, wherein the location sensor body includes at least one sensor configured to detect a magnetic element included with the ECG stylet.

7. The location sensor assembly as defined in claim **1**, wherein the removable connector interface is removably received within a pocket defined on the location sensor body, the pocket including the console port and the ECG port.

8. The location sensor assembly as defined in claim **7**, wherein the removable connector interface is configured to be disposed in the pocket via a friction fit, and wherein an outer surface of the removable connector interface matches an outer surface of the location sensor body when the removable connector interface is disposed in the pocket.

9. The location sensor assembly as defined in claim **1**, wherein the removable connector interface further comprises a recess including one or more ECG lead contacts in communication with the ECG connection interface.

10. The location sensor assembly as defined in claim **1**, wherein the stylet connection interface is configured to connect to a stylet connector through a drape, wherein the drape is configured to provide a sterile barrier, and wherein the stylet connection interface is designed to connect to the stylet connector through the drape without compromising the sterile barrier of the drape.

11. The location sensor assembly as defined in claim **1**, wherein the location sensor body is designed to be temporarily disposed on a chest portion of a patient.

12. The location sensor assembly as defined in claim **1**, wherein during use of the catheter placement system, the

13

location sensor body is disposed on a chest portion of the patient, the removable connector interface is removably attached to a pocket defined in the location sensor body, and an ECG stylet is operably connected to the location sensor body via the removable connector interface.

13. The location sensor assembly as defined in claim 12, wherein a console is operably connected to the location sensor body via the removable connector interface and wherein a plurality of external ECG electrodes are operably connected to the location sensor body via the removable connector interface.

14. The location sensor assembly as defined in claim 1, wherein the removable connector interface includes a cable permanently attached thereto.

15. The location sensor assembly as defined in claim 14, wherein the cable includes a USB cable that operably connects the location sensor body to a console of the catheter placement system.

16. The location sensor assembly as defined in claim 1, wherein the removable connector interface is a replaceable component and is configured for use in multiple procedures to position catheters.

17. The location sensor assembly as defined in claim 1, wherein an ECG stylet and at least one external ECG electrode are disposable and are configured to operably connect to the removable connector interface.

18. The location sensor assembly as defined in claim 17, wherein electrical contacts for the ECG stylet and the at least one external ECG electrode are disposed on the removable connector interface.

19. A catheter placement system for placing a catheter in a body of a patient, comprising:

- a system console;
- a location sensor operably connected to the system console via a console cable, the location sensor comprising:
 - a console port;
 - an electrocardiogram (ECG) port; and
 - a stylet connector recess;
- an ECG stylet configured to be removably disposed within a lumen of the catheter, and to detect ECG signals when a distal portion of the catheter is disposed in the body of the patient, the ECG stylet including an electrically conductive stylet connector;

14

at least one external ECG electrode configured to be placed on the body of the patient; and

- a connector interface configured to removably attach to the location sensor, the connector interface including:
 - a console connection interface designed for mating with the console port;
 - an electrocardiogram (ECG) connection interface designed for mating with the ECG port; and
 - a stylet connection interface designed for mating with the stylet connector recess,
 wherein the connector interface enables simultaneous mating upon attachment to the location sensor.

20. The system as defined in claim 19, wherein the stylet connection interface includes a receptacle, wherein the stylet connector of the ECG stylet includes a pin connector, and wherein the receptacle is configured to receive the pin connector of the ECG stylet therein, the pin connector configured to pierce a sterile barrier disposed over the location sensor and the connector interface.

21. The system as defined in claim 20, wherein the pin connector is disposed in a channel of a tether connector body included with the ECG stylet.

22. The system as defined in claim 21, wherein the receptacle is included on a fin that extends from a body of the connector interface, the fin including a rounded leading edge.

23. The system as defined in claim 20, wherein the sterile barrier includes a surgical drape.

24. The system as defined in claim 19, wherein the connector interface is removably attachable to a pocket defined in the location sensor and wherein the connector interface enables the location sensor to receive ECG signals from the ECG stylet and from the at least one external ECG electrode.

25. The system as defined in claim 24, wherein a rail of the connector interface is received within a track of the location sensor when the connector interface is attached within the pocket of the location sensor, the track including a recessed perimeter.

26. The system as defined in claim 19, wherein the connector interface includes an outer surface that matches an outer surface of the location sensor when the connector interface is attached to the location sensor.

* * * * *

专利名称(译)	基于ECG的导管定位系统的连接器接口		
公开(公告)号	US10349890	公开(公告)日	2019-07-16
申请号	US15/192561	申请日	2016-06-24
申请(专利权)人(译)	C. R. BARD , INC.		
当前申请(专利权)人(译)	C. R. BARD , INC.		
[标]发明人	MISENER ANTHONY K DAVIS ZACHARY S STATS JASON R		
发明人	MISENER, ANTHONY K. DAVIS, ZACHARY S. STATS, JASON R.		
IPC分类号	A61B5/04 A61M25/01 A61B5/0404 A61B5/00 A61B5/042 A61B5/06		
CPC分类号	A61B5/6852 A61B5/042 A61B5/0404 A61M25/01 A61B5/062 A61M2230/04 A61B2562/227		
代理机构(译)	鲁坦和塔克LLP		
优先权	62/185477 2015-06-26 US		
其他公开文献	US20160374589A1		
外部链接	Espacenet		

摘要(译)

公开了一种连接器接口，其被配置为实现与导管放置系统的位置传感器的部件互连。导管放置系统被配置为帮助临床医生将导管定位在患者体内的期望位置。在一个实施例中，位置传感器组件包括用于临时放置在患者身体的一部分上的位置传感器主体，以及连接器接口。连接器接口被配置成可移除地附接到位置传感器并在位置传感器和导管放置系统的附加部件之间提供多个导电通路，以使附加部件能够与位置传感器可操作地连接。连接器接口还包括第一连接器，该第一连接器构造成通过插入在第一和第二连接器之间的盖布可操作地与导管放置系统的一个附加部件的第二连接器连接。

