



US010149622B2

(12) **United States Patent**  
**Narayan et al.**

(10) **Patent No.:** **US 10,149,622 B2**  
(45) **Date of Patent:** **Dec. 11, 2018**

(54) **SYSTEM AND METHOD FOR RECONSTRUCTING CARDIAC ACTIVATION INFORMATION**

(58) **Field of Classification Search**  
CPC ..... A61B 5/04011; A61B 5/04012; A61B 5/0422; A61B 5/0452; A61B 5/046; (Continued)

(71) Applicants: **The Regents of the University of California**, Oakland, CA (US); **Topera, Inc.**, Menlo Park, CA (US)

(56) **References Cited**

U.S. PATENT DOCUMENTS

(72) Inventors: **Sanjiv Narayan**, La Jolla, CA (US); **Carey Robert Briggs**, La Jolla, CA (US)

4,421,114 A 12/1983 Berkovits et al.  
4,630,204 A 12/1986 Mortara  
(Continued)

(73) Assignees: **The Regents of the University of California**, Oakland, CA (US); **Topera, Inc.**, Menlo Park, CA (US); **The United States of America as Represented by the Department of Veteran's Affairs**, Washington, DC (US)

FOREIGN PATENT DOCUMENTS

CN 101461711 A 6/2009  
EP 0284685 A2 10/1988  
(Continued)

OTHER PUBLICATIONS

(\* ) Notice: Subject to any disclaimer, the term of this patent is extended or adjusted under 35 U.S.C. 154(b) by 0 days.

Houben, R.P.M., et al, "Automatic mapping of human atrial fibrillation by template matching", Heart Rhythm, vol. 3, No. 10, Oct. 1, 2006, pp. 1221-1228.

(Continued)

(21) Appl. No.: **15/244,792**

*Primary Examiner* — Catherine Voorhees

(22) Filed: **Aug. 23, 2016**

*Assistant Examiner* — Roland Dinga

(65) **Prior Publication Data**

US 2016/0360983 A1 Dec. 15, 2016

(74) *Attorney, Agent, or Firm* — Eleanor Musick; Musick Davison LLP

**Related U.S. Application Data**

(57) **ABSTRACT**

(63) Continuation of application No. 14/724,621, filed on May 28, 2015, now Pat. No. 9,468,387, which is a (Continued)

In a system and method of reconstructing cardiac activation information, pairs of cardiac signals obtained from a patient are accessed. The pairs have a first cardiac signal that is common among the pairs and second cardiac signals that are different among the pairs. The first cardiac signal and the second cardiac signals are processed to identify points of change in the first cardiac signal at which a derivative of the first cardiac signal diverges with respect to derivatives of the second cardiac signals. An activation onset time is assigned at a point in the first cardiac signal based on correspondence of the points of change to define a cardiac activation indicating a beat.

(51) **Int. Cl.**  
**A61B 5/024** (2006.01)  
**A61B 5/042** (2006.01)  
(Continued)

(52) **U.S. Cl.**  
CPC ..... **A61B 5/02405** (2013.01); **A61B 5/0002** (2013.01); **A61B 5/0205** (2013.01);  
(Continued)

**12 Claims, 8 Drawing Sheets**

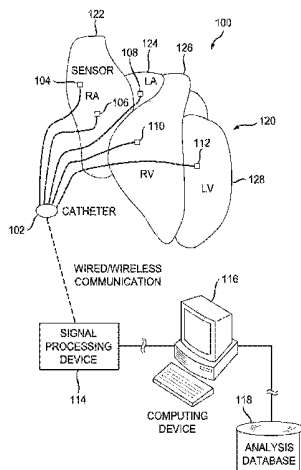

**Related U.S. Application Data**

continuation of application No. 14/473,905, filed on Aug. 29, 2014, now Pat. No. 9,055,878, which is a continuation-in-part of application No. 14/074,619, filed on Nov. 7, 2013, now Pat. No. 9,055,876, which is a continuation of application No. 13/438,534, filed on Apr. 3, 2012, now Pat. No. 8,594,777, which is a continuation of application No. 13/217,123, filed on Aug. 24, 2011, now Pat. No. 8,165,666.

(60) Provisional application No. 61/481,607, filed on May 2, 2011.

(51) **Int. Cl.**

- A61B 5/0452* (2006.01)
- A61B 5/00* (2006.01)
- A61B 5/0205* (2006.01)
- A61B 5/04* (2006.01)
- A61B 5/046* (2006.01)
- A61B 5/0464* (2006.01)
- A61B 5/0255* (2006.01)
- A61B 18/02* (2006.01)
- A61B 18/12* (2006.01)
- A61B 18/18* (2006.01)
- A61B 18/00* (2006.01)

(52) **U.S. Cl.**

CPC ..... *A61B 5/0255* (2013.01); *A61B 5/046* (2013.01); *A61B 5/0401I* (2013.01); *A61B 5/04012* (2013.01); *A61B 5/0422* (2013.01); *A61B 5/0452* (2013.01); *A61B 5/0464* (2013.01); *A61B 5/4836* (2013.01); *A61B 5/6852* (2013.01); *A61B 5/7203* (2013.01); *A61B 5/7217* (2013.01); *A61B 5/7239* (2013.01); *A61B 5/7246* (2013.01); *A61B 5/7278* (2013.01); *A61B 5/7282* (2013.01); *A61B 5/742* (2013.01); *A61B 5/743* (2013.01); *A61B 18/02* (2013.01); *A61B 18/12* (2013.01); *A61B 18/18* (2013.01); *A61B 2018/00577* (2013.01); *A61B 2562/046* (2013.01)

(58) **Field of Classification Search**

CPC ... *A61B 5/4836*; *A61B 5/6852*; *A61B 5/7203*; *A61B 5/7246*; *A61B 5/7278*; *A61B 5/7282*; *A61B 5/742*; *A61B 5/743*; *A61B 18/02*; *A61B 18/12*; *A61B 18/18*; *A61B 2018/00577*; *A61B 2562/046*; *A61B 5/02405*; *A61B 5/002*; *A61B 5/0255*; *A61B 5/0205*; *A61B 5/0464*

USPC ..... 600/515

See application file for complete search history.

(56) **References Cited**

U.S. PATENT DOCUMENTS

- 4,754,763 A 7/1988 Doemland
- 4,905,707 A 3/1990 Davies et al.
- 4,905,708 A 3/1990 Davies
- 5,029,082 A 7/1991 Shen et al.
- 5,092,341 A 3/1992 Kelen
- 5,121,750 A 6/1992 Katims
- 5,172,699 A 12/1992 Svenson et al.
- 5,178,154 A 1/1993 Ackmann et al.
- 5,366,487 A 11/1994 Adams et al.
- 5,427,112 A 6/1995 Noren et al.
- 5,433,198 A 7/1995 Desai
- 5,439,483 A 8/1995 Duong-Van
- 5,450,846 A 9/1995 Goldreyer
- 5,458,621 A 10/1995 White et al.

- 5,480,422 A 1/1996 Ben-Haim
- 5,487,391 A 1/1996 Panescu
- 5,582,173 A 12/1996 Li
- 5,645,070 A 7/1997 Turcott
- 5,657,755 A 8/1997 Desai
- 5,662,108 A 9/1997 Budd et al.
- 5,687,737 A 11/1997 Branham et al.
- 5,718,241 A 2/1998 Ben-Haim et al.
- 5,795,303 A 8/1998 Swanson et al.
- 5,810,740 A 9/1998 Paisner
- 5,817,134 A 10/1998 Greenhut et al.
- 5,819,740 A 10/1998 Muhlenberg
- 5,836,889 A 11/1998 Wyborny et al.
- 5,840,025 A 11/1998 Ben-Haim
- 5,848,972 A 12/1998 Triedman et al.
- 5,868,680 A 2/1999 Steiner et al.
- 5,954,661 A 9/1999 Greenspon et al.
- 5,954,665 A 9/1999 Ben-Haim
- 6,052,618 A 4/2000 Dahlke et al.
- 6,066,094 A 5/2000 Ben-Haim
- 6,115,628 A 5/2000 Stadler et al.
- 6,097,983 A 8/2000 Strandberg
- 6,112,117 A 8/2000 Kenknight et al.
- 6,188,924 B1 2/2001 Swanson et al.
- 6,208,888 B1 3/2001 Yonce
- 6,236,883 B1 5/2001 Ciaccio et al.
- 6,251,125 B1 6/2001 Kenknight et al.
- 6,256,540 B1 7/2001 Panescu et al.
- 6,301,496 B1 10/2001 Reisfeld
- 6,324,421 B1 11/2001 Stadler et al.
- 6,360,121 B1 3/2002 Shoda
- 6,397,100 B2 5/2002 Stadler et al.
- 6,438,406 B2 8/2002 Yonce
- 6,438,409 B1 8/2002 Malik et al.
- 6,449,503 B1 9/2002 Hsu
- 6,510,339 B2 1/2003 Kovtun et al.
- 6,522,905 B2 2/2003 Desai
- 6,539,256 B1 3/2003 Kenknight et al.
- 6,542,773 B2 4/2003 Dupree et al.
- 6,553,251 B1 4/2003 Lähdesmäki
- 6,584,345 B2 6/2003 Govari
- 6,725,085 B2 4/2004 Schwartzman et al.
- 6,738,655 B1 5/2004 Sen et al.
- 6,788,969 B2 9/2004 Dupree et al.
- 6,847,839 B2 1/2005 Ciaccio et al.
- 6,856,830 B2 2/2005 He
- 6,889,081 B2 5/2005 Hsu
- 6,892,091 B1 5/2005 Ben-Haim et al.
- 6,920,350 B2 7/2005 Xue et al.
- 6,941,166 B2 9/2005 MacAdam et al.
- 6,950,696 B2 9/2005 Bjorling et al.
- 6,950,702 B2 9/2005 Sweeney
- 6,959,212 B2 10/2005 Hsu et al.
- 6,975,900 B2 12/2005 Rudy et al.
- 6,978,168 B2 12/2005 Beatty et al.
- 6,985,768 B2 1/2006 Hemming et al.
- 7,016,719 B2 3/2006 Rudy et al.
- 7,043,292 B2 5/2006 Tarjan et al.
- 7,076,288 B2 7/2006 Skinner
- 7,117,030 B2 10/2006 Berenfeld et al.
- 7,123,954 B2 10/2006 Narayan et al.
- 7,206,630 B1 4/2007 Tarler
- 7,215,993 B2 5/2007 Lin
- 7,245,962 B2 7/2007 Ciaccio et al.
- 7,263,397 B2 8/2007 Hauck et al.
- 7,283,865 B2 10/2007 Noren
- 7,289,843 B2 10/2007 Beatty et al.
- 7,289,845 B2 10/2007 Sweeney et al.
- 7,328,063 B2 2/2008 Zhang et al.
- 7,369,890 B2 5/2008 Lovett
- 7,457,664 B2 11/2008 Zhang et al.
- 7,505,810 B2 3/2009 Harlev et al.
- 7,509,170 B2 3/2009 Zhang et al.
- 7,515,954 B2 4/2009 Harlev et al.
- 7,567,835 B2 7/2009 Gunderson
- 7,580,744 B2 8/2009 Hsu
- 7,620,446 B2 11/2009 Ferek-Petric
- 7,657,307 B2 2/2010 Dam et al.
- 7,729,753 B2 6/2010 Kremliovsky et al.

(56)

## References Cited

## U.S. PATENT DOCUMENTS

7,734,333	B2	6/2010	Ghanem et al.	2006/0161206	A1	7/2006	Efimov et al.
7,734,336	B2	6/2010	Ghanem et al.	2007/0016261	A1	1/2007	Dong et al.
7,738,948	B2	6/2010	Rouw et al.	2007/0055167	A1	9/2007	Bullinga
7,742,812	B2	6/2010	Ghanem et al.	2007/0208260	A1	9/2007	Afonso
7,751,882	B1	7/2010	Helland	2007/0208263	A1	9/2007	John et al.
7,761,142	B2	7/2010	Ghanem et al.	2007/0232948	A1	10/2007	Stadler et al.
7,761,150	B2	7/2010	Ghanem et al.	2007/0239051	A1	10/2007	Ghanem et al.
7,769,452	B2	8/2010	Ghanem et al.	2007/0299351	A1	12/2007	Harlev et al.
7,801,594	B1	9/2010	Higham	2008/0097539	A1	4/2008	Belalcazar et al.
7,907,993	B2	3/2011	Ghanem et al.	2008/0109041	A1	5/2008	de Voir
7,907,994	B2	3/2011	Stolarski et al.	2008/0114258	A1	5/2008	Zhang et al.
7,930,018	B2	4/2011	Harlev et al.	2008/0188765	A1	8/2008	Stolarski et al.
7,930,020	B2	4/2011	Zhang et al.	2008/0208012	A1	8/2008	Ali
7,953,475	B2	5/2011	Harlev et al.	2008/0269624	A1	10/2008	Zhang et al.
7,962,202	B2	6/2011	Bhunia	2008/0319332	A1	12/2008	Sommo et al.
8,050,732	B2	11/2011	Desai	2009/0069704	A1	3/2009	MacAdam et al.
8,050,751	B2	11/2011	Zhang et al.	2009/0099468	A1	4/2009	Thiagalingam et al.
8,050,757	B2	11/2011	Hsu	2009/0099618	A1	4/2009	Rousso et al.
8,095,205	B2	1/2012	Bhunia	2009/0112106	A1	4/2009	Zhang
8,095,206	B2	1/2012	Ghanem et al.	2009/0112110	A1	4/2009	Zhang et al.
8,160,684	B2	4/2012	Ghanem et al.	2009/0112199	A1	4/2009	Zhang et al.
8,165,666	B1	4/2012	Briggs et al.	2009/0131760	A1	5/2009	Ali et al.
8,165,671	B2	4/2012	Freeman et al.	2009/0163968	A1	6/2009	Donofrio
8,175,702	B2	5/2012	Efimov et al.	2009/0177071	A1	7/2009	Harlev et al.
8,306,618	B2	11/2012	Ghanem et al.	2009/0177072	A1	7/2009	Harlev et al.
8,315,697	B2	11/2012	Hsu	2009/0259266	A1	10/2009	Zhang et al.
8,340,766	B2	12/2012	Ryu et al.	2009/0299203	A1	12/2009	de Voir et al.
8,386,024	B2	2/2013	Gunderson et al.	2010/0026543	A1	2/2010	Tsai et al.
8,435,185	B2	5/2013	Ghanem et al.	2010/0204592	A1	8/2010	Hatib et al.
8,489,171	B2	7/2013	Hauck et al.	2010/0217143	A1	8/2010	Whittington et al.
8,521,266	B2	8/2013	Narayan et al.	2010/0239627	A1	9/2010	Zhang et al.
8,588,885	B2	11/2013	Hall et al.	2010/0298729	A1	11/2010	Zhang et al.
8,594,777	B2	11/2013	Briggs et al.	2010/0305456	A1	12/2010	Brainard, II
8,639,325	B2	1/2014	Efimov et al.	2010/0324435	A1	12/2010	Higham
8,676,303	B2	3/2014	Narayan	2011/0077540	A1	3/2011	Belalcazar
8,700,140	B2	4/2014	Narayan et al.	2011/0087121	A1	4/2011	Zhang et al.
8,715,199	B1	5/2014	Macneil et al.	2011/0112425	A1	5/2011	Muhlsteff et al.
8,812,074	B2	8/2014	Kordis et al.	2011/0118803	A1	5/2011	Hou et al.
8,838,222	B2	9/2014	Narayan et al.	2011/0130801	A1	6/2011	Maskara et al.
8,838,223	B2	9/2014	Narayan et al.	2011/0196249	A1	8/2011	Staeuber et al.
8,868,169	B2	10/2014	Narayan et al.	2011/0257547	A1	10/2011	Zhang et al.
9,031,642	B2	5/2015	Ghosh	2011/0282227	A1	11/2011	Zhang
9,050,006	B2	6/2015	Narayan et al.	2012/0184858	A1	7/2012	Harlev et al.
9,055,876	B2	6/2015	Narayan et al.	2012/0184863	A1	7/2012	Harlev et al.
9,055,877	B2	6/2015	Narayan et al.	2012/0232417	A1	9/2012	Zhang et al.
9,055,878	B2	6/2015	Narayan et al.	2013/0245474	A1	9/2013	Nicolson et al.
9,089,269	B2	7/2015	Narayan et al.	2013/0324871	A1	12/2013	Dubois et al.
9,107,600	B2	8/2015	Narayan et al.	2013/0345577	A1	12/2013	Thakur et al.
9,220,427	B2	12/2015	Narayan et al.	2014/0005562	A1	1/2014	Bunch et al.
9,241,667	B2	1/2016	Narayan et al.	2014/0114204	A1	4/2014	Narayan et al.
9,282,910	B2	3/2016	Narayan et al.	2014/0235988	A1	8/2014	Ghosh
9,332,915	B2	5/2016	Narayan et al.	2014/0336520	A1	11/2014	Zeng et al.
9,375,156	B2	6/2016	Narayan et al.	2014/0371609	A1	12/2014	Narayan et al.
9,380,950	B2	7/2016	Narayan et al.	2014/0371613	A1	12/2014	Narayan et al.
9,392,948	B2	7/2016	Briggs et al.	2015/0038861	A1	2/2015	Narayan et al.
9,393,425	B2	7/2016	Narayan	2015/0366476	A1*	12/2015	Laughner ..... A61B 5/743 600/374
9,398,860	B2	7/2016	Macneil et al.	2016/0015283	A1	1/2016	Narayan et al.
9,398,883	B2	7/2016	Narayan et al.	2016/0022163	A1	1/2016	Narayan et al.
9,408,536	B2	8/2016	Narayan et al.	2016/0095531	A1	4/2016	Narayan et al.
9,439,573	B2	9/2016	Narayan et al.	2016/0166167	A1	6/2016	Narayan et al.
9,468,387	B2	10/2016	Narayan et al.	2016/0262643	A1	9/2016	Ng et al.
9,549,684	B2	1/2017	Narayan et al.	2016/0278657	A1	9/2016	Narayan et al.
2002/0010392	A1	1/2002	Desai	2016/0302734	A1	10/2016	Narayan
2003/0018277	A1	1/2003	He	2016/0324434	A1	11/2016	Briggs et al.
2003/0083587	A1	5/2003	Ferek-Petric	2016/0360983	A1	12/2016	Narayan et al.
2003/0236466	A1	12/2003	Tarjan	2016/0374571	A1	12/2016	Narayan et al.
2004/0073262	A1	4/2004	Lovett	2017/0007176	A1	1/2017	Narayan et al.
2004/0093035	A1	5/2004	Schwartz et al.	2017/0049402	A1	2/2017	Narayan et al.
2004/0243014	A1	12/2004	Lee et al.	2017/0245774	A1	8/2017	Narayan et al.
2005/0027321	A1	2/2005	Ferek-Petric	2017/0311835	A1	11/2017	Narayan et al.
2005/0137638	A1	6/2005	Yonce et al.	2017/0340229	A1	11/2017	Narayan et al.
2005/0148892	A1	7/2005	Desai				
2005/0203502	A1	9/2005	Boveja et al.				
2006/0084970	A1	4/2006	Beatty et al.				
2006/0161069	A1	7/2006	Li				

## FOREIGN PATENT DOCUMENTS

EP	2269691	A2	1/2011
EP	1808124	B1	4/2011
EP	2638854	A1	9/2013
JP	H09215667	A	8/1997

(56) **References Cited**

## FOREIGN PATENT DOCUMENTS

WO	1994021168	A1	9/1994
WO	1996025096	A1	8/1996
WO	1996032885	A1	10/1996
WO	1996032897	A1	10/1996
WO	1996039929	A1	12/1996
WO	1997024983	A1	7/1997
WO	2000045700	A1	8/2000
WO	2003011112	A1	2/2003
WO	2005035046	A2	4/2005
WO	2005115232	A1	12/2005
WO	2006052838	A2	5/2006
WO	2006066324	A1	6/2006
WO	2007078421	A2	7/2007
WO	2007106829	A2	9/2007
WO	2007137077	A1	11/2007
WO	2007146864	A1	12/2007
WO	2008035070	A3	3/2008
WO	2008138009	A1	11/2008
WO	2013150740	A1	10/2013

## OTHER PUBLICATIONS

Nademanee, Koonlawee, et al., "A new approach for catheter ablation of atrial fibrillation: mapping of the electrophysiologic substrate", *J. Amer.Coll.Cardiol.*, vol. 43, No. 11, Jun. 2, 2004, pp. 2044-2053.

Narayan, S.M., et al., "Dynamics factors preceding the initiation of atrial fibrillation in humans", *Heart Rhythm*, vol. 5, No. 6, Jun. 1, 2008, pp. S22-S25.

Ciacco, Edward J. et al., "Development of Gradient Descent Adaptive Algorithms to Remove Common Mode Artifact for Improvement of Cardiovascular Signal Quality", *Annals of Biomedical Engineering*, vol. 35, No. 7, Jul. 2007, pp. 1146-1155.

Sornborger, Andrew, et al., "Extraction of Periodic Multivariate Signals: Mapping of Voltage-Dependent Dye fluorescence in the Mouse Heart", *IEEE Transactions on Medical Imaging*, vol. 22, No. 12, Dec. 2003, pp. 1537-1549.

Sun, Yan, et al., "Characteristic wave detection in ECG signal using morphological transform", *BMC Cardiovascular Disorders*, vol. 5, No. 28, 2005.

Tai, Dean C.S., et al., "Correction of motion artifact in transmembrane voltage-sensitive fluorescent dye emission in hearts", *Am. J. Physiol. Heart Circ. Physiol.*, vol. 287, 2004, pp. H985-H993.

Lin, Y-J, et al., "Electrophysiological Characteristics and Catheter Ablation in Patients With Paroxysmal Right Atrial Fibrillation", *Circulation*, Sep. 20, 2005; 112(12): 1692-1700, EPub Sep. 12, 2005.

Houben, R.P.M., et al., "Processing of Intracardiac Electrograms in Atrial Fibrillation", *IEEE Engineering in Medicine and Biology Magazine*, Nov./Dec. 2006, pp. 40-51.

Saksena, S., et al., "Regional Endocardial Mapping of Spontaneous and Induced Atrial Fibrillation in Patients With Heart Disease and Refractory Atrial Fibrillation", *Am J Cardiol*, 1999; 84:880-889.

PCT/US2011/031468: International Preliminary Report on Patentability, dated Oct. 9, 2012, 8 pages.

PCT/US2009/060178: International Preliminary Report on Patentability, dated Apr. 12, 2011, 10 pages.

PCT/US2011/031470: International Preliminary Report on Patentability, dated Oct. 9, 2012, 7 pages.

PCT/US2012/029935: International Search Report and Written Opinion, dated Nov. 8, 2012, 9 pages.

PCT/US2012/036157: International Preliminary Report on Patentability, dated Nov. 5, 2013, 8 pages.

PCT/US2012/068640: International Preliminary Report on Patentability, dated Jun. 10, 2014, 5 pages.

PCT/US2012/068639: International Preliminary Report on Patentability, dated Jun. 10, 2014, 6 pages.

EP09819953: Supplementary European Search Report and European Search Opinion, dated Feb. 7, 2012, 5 pages.

EP12711553: Supplementary European Search Report and European Search Opinion, dated Sep. 11, 2013, 7 pages.

Umapathy, K., et al. "Spatiotemporal Frequency Analysis of Ventricular Fibrillation in Explanted Human Hearts," *IEEE Transactions in Biomedical Engineering*, IEEE Service Center, Piscataway, NJ USA, vol. 56, No. 2, Feb. 1, 2009, pp. 328-335.

Kalifa, J., et al. "Mechanisms of wave fractionation at boundaries of high-frequency excitation in the posterior left atrium of the isolated sheep heart during atrial fibrillation," *Circulation*, vol. 113, No. 5, Feb. 7, 2006, pp. 626-633.

Yenn-Jiang L., et al. "Electrophysiological Mechanisms and Catheter Ablation of Complex Atrial Arrhythmias from Crista Terminalis: Insight from Three-Dimensional Noncontact Mapping," *Pacing and Clinical Electrophysiology*, vol. 27, No. 9, Sep. 1, 2004, pp. 1231-1239.

EP12779506.0: Supplementary European Search Report & European Search Opinion, dated Nov. 18, 2014, 8 pages.

English-language translation of Chinese patent publication No. CN 101461711A, published Jun. 24, 2009.

EP14763969.4 Supplementary European Search Report & European Search Opinion dated Oct. 21, 2016, 7 pages.

EP147665096.4 Supplementary European Search Report & European Search Opinion, dated Oct. 21, 2016, 6 pages.

EP15192804.1 Supplementary European Search Report, dated Feb. 18, 2016, 7 pages.

Jung, TP et al. Removing Electroencephalographic Artifacts by Blind Source Separation, *Psychophysiology*, 37.02 (2000): 163-178.

PCT/US2014/029616 International Search Report and Written Opinion, dated Sep. 18, 2014; 9 pages.

PCT/US2014/029645 International Search Report and Written Opinion, dated Aug. 18, 2014, 17 pages.

PCT/US2015/023929, International Search Report and Written Opinion, dated Jul. 9, 2015, 8 pages.

PCT/US2015/046742 International Search Report and Written Opinion; dated Dec. 1, 2015, 5 pages.

Holm, M. et al., "A New Method for Analysis of Atrial Activation During Chronic Atrial Fibrillation in Man", *IEEE Transactions on Biomedical Engineering*, vol. 43, No. 2, Feb. 1, 1996, pp. 198-210.

Kadish, A., et al., "Characterization of fibrillatory rhythms by ensemble vector directional analysis", *Am J Physiol.—Heart Circ. Physiol.*, vol. 285, Oct. 2003, pp. H1705-H1719.

Masse, S., et al., "Wave similarity of human ventricular fibrillation from bipolar electrograms", *Eurospace (2007) vol. 9*, pp. 10-19.

Ulphani, J.S., et al., "Frequency gradients during two different forms of fibrillation in canine atria", *Heart Rhythm*, vol. 1, No. 10, Oct. 2007, pp. 1315-1323.

EP12855266.8: Supplementary European Search Report & European Search Opinion, dated Jun. 2, 2015, 9 pages.

EP12855738.6: Supplementary European Search Report & European Search Opinion, dated Jun. 5, 2015, 9 pages.

Eckman, et al., "Recurrence plots of dynamical systems," *Europhys. Lett.*, 4 (3), Nov. 1, 1987 pp. 973-977.

Botteron, G.W. et al., A technique for measurement of the extent of spatial organization of atrial activation during atrial fibrillation in the intact human ar, *IEEE Transactions on Biomedical Engineering*, Jun. 1995, pp. 579-586, vol. 42, No. 6.

Censi, F. et al., "Recurrent Patterns of Atrial Depolarization During Atrial Fibrillation Assessed by Recurrence Plot Quantification", *Annals of Biomedical Engineering*, 2000, pp. 61-70; vol. 28.

EP15774130.7 Supplementary European Search Report & European Search Opinion, dated Nov. 15, 2017, 9 pages.

EP15836641 Supplementary European Search Report & European Search Opinion, dated Mar. 8, 2018, 8 pages.

PCT/US2017/030683, International Search Report and Written Opinion, dated Aug. 1, 2017, 6 pages.

Xiao, Yuping et al., Parameter estimation of spiral waves from atrial electrograms., *Proceedings of International Conference on Acoustics, Speech and Signal Processing (ICASSP '03) Apr. 6-10, 2003, Hong Kong, China, IEEE, 2003 IEEE International Conference*, vol. 5, Apr. 6, 2003, pp. V\_245-V\_248.

\* cited by examiner

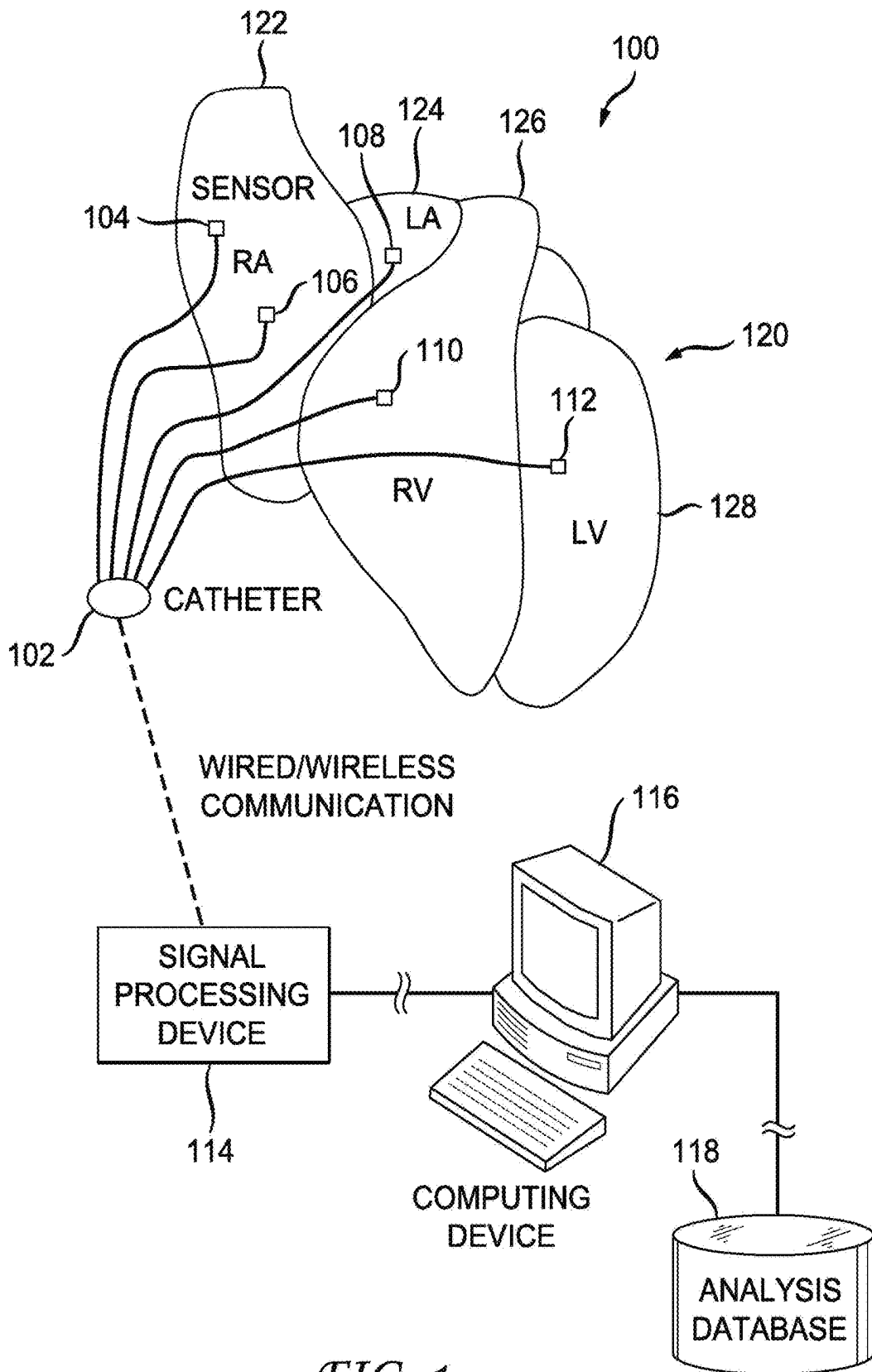

FIG. 1

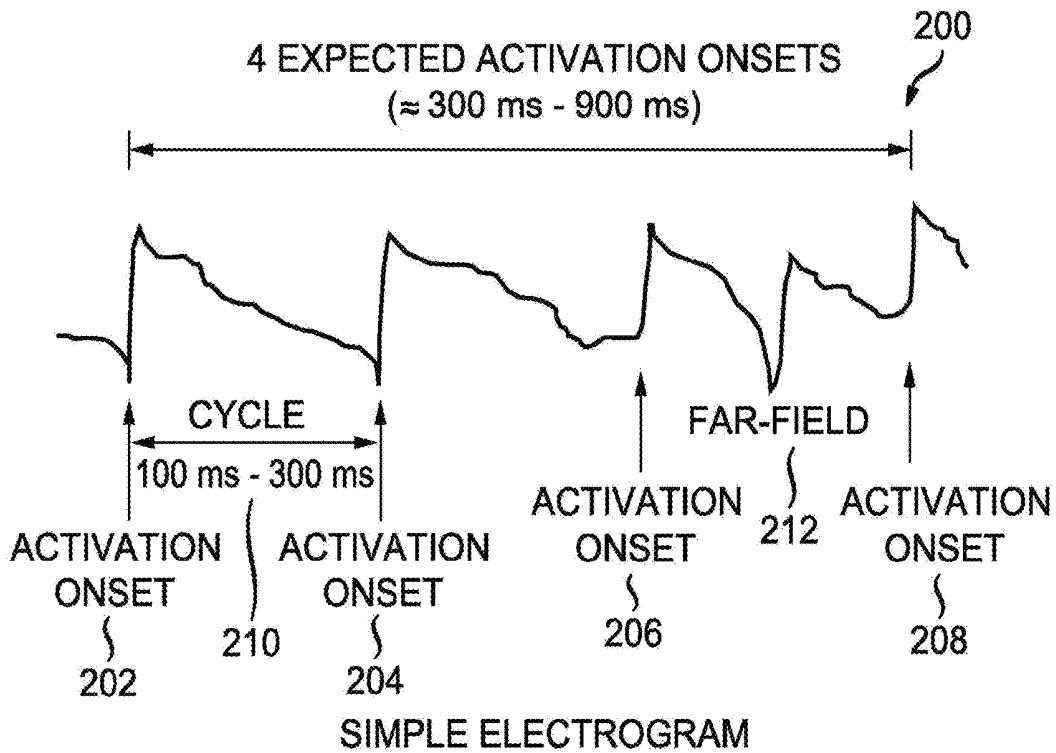

FIG. 2

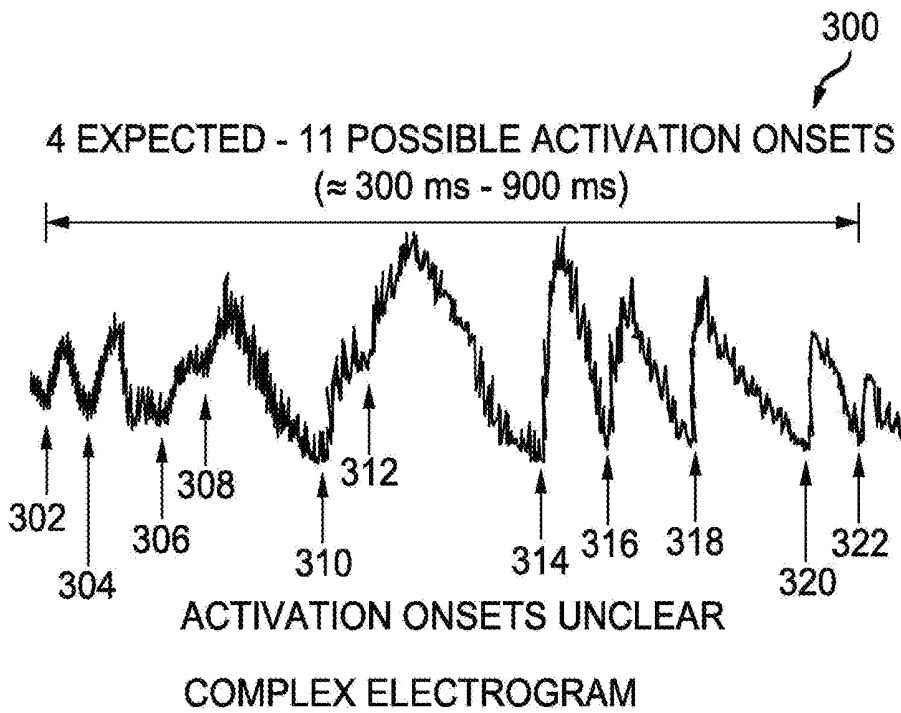
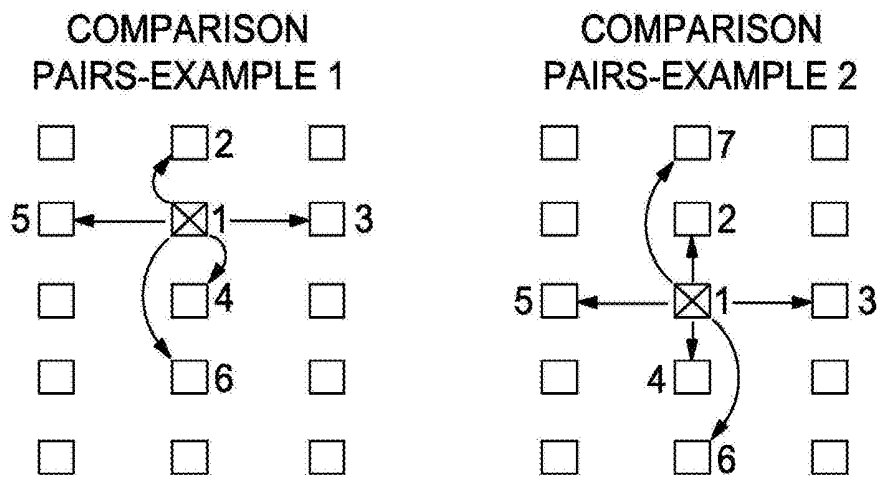
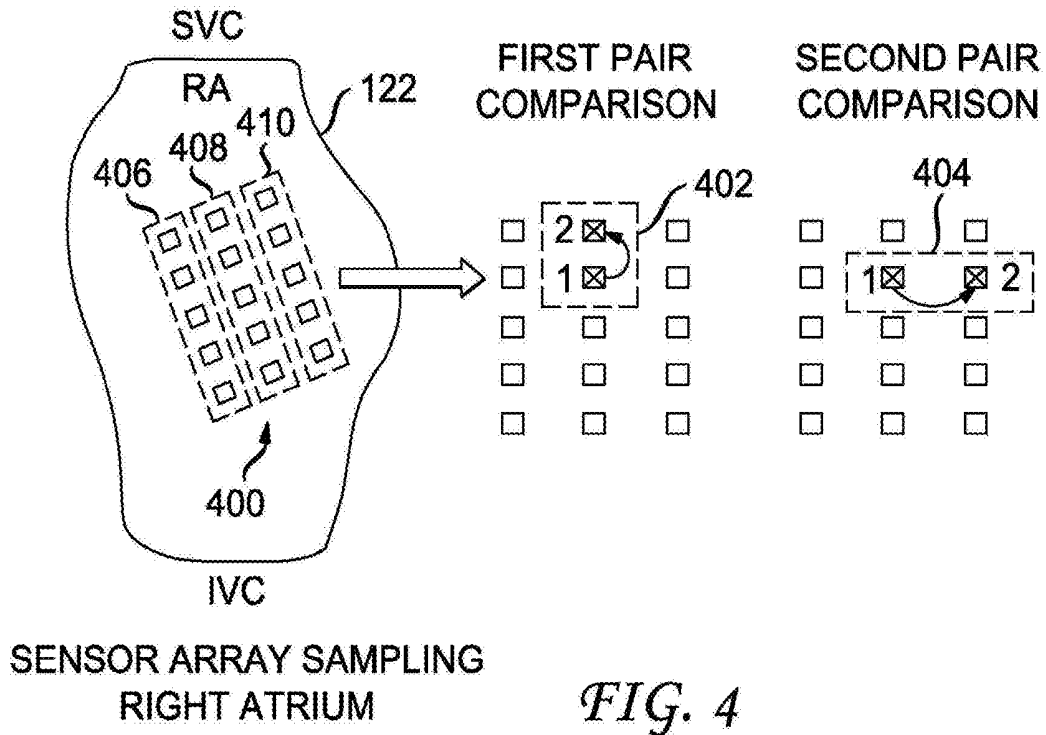

FIG. 3



*FIG. 5*

FAR-FIELD ACTIVATION  
(NOT SIGNIFICANTLY LOCAL)

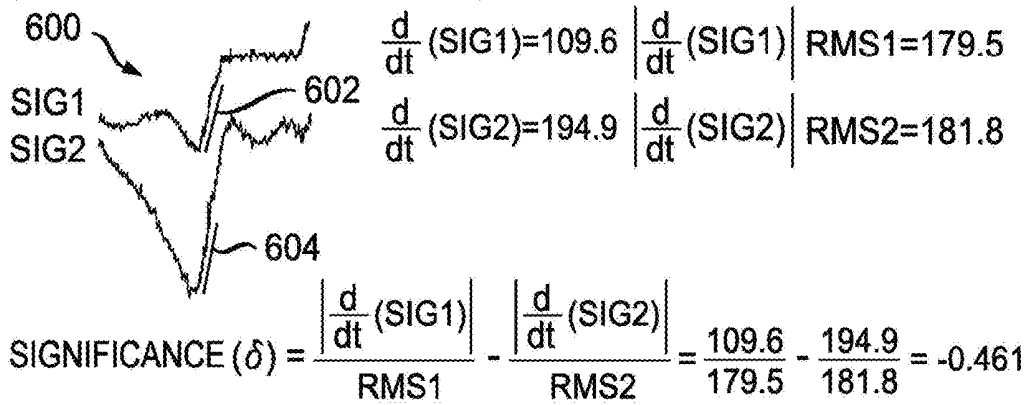

FIG. 6

BACKGROUND NOISE

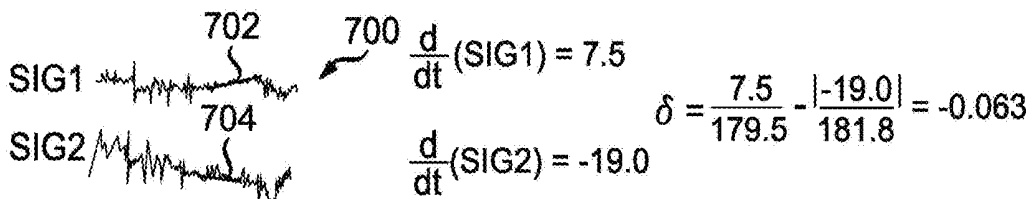
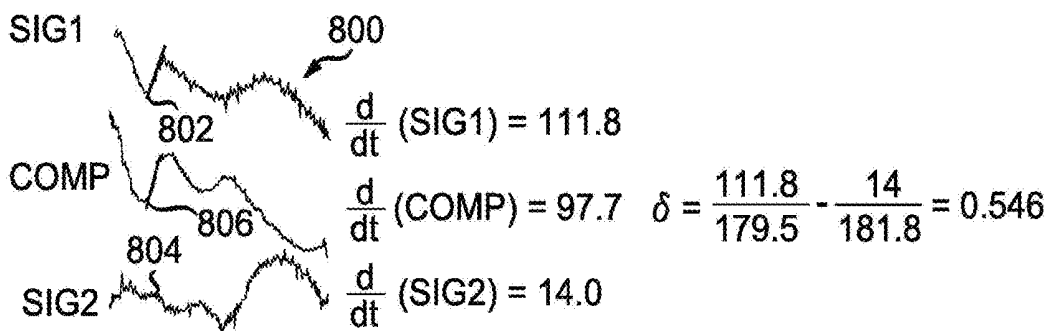

FIG. 7

LOCAL ACTIVATION ONSET



USING THE COMPOSITE:

$$\delta = \frac{\left| \frac{d}{dt}(\text{SIG2}) \right| - \left| \frac{d}{dt}(\text{COMP}) \right|}{\ln \left[ \left| \frac{d}{dt}(\text{SIG1}) - \frac{d}{dt}(\text{COMP}) \right| \right]} = \frac{|14 - 97.7|}{\ln [|111.8 - 97.7|]} = 31.63$$

FIG. 8

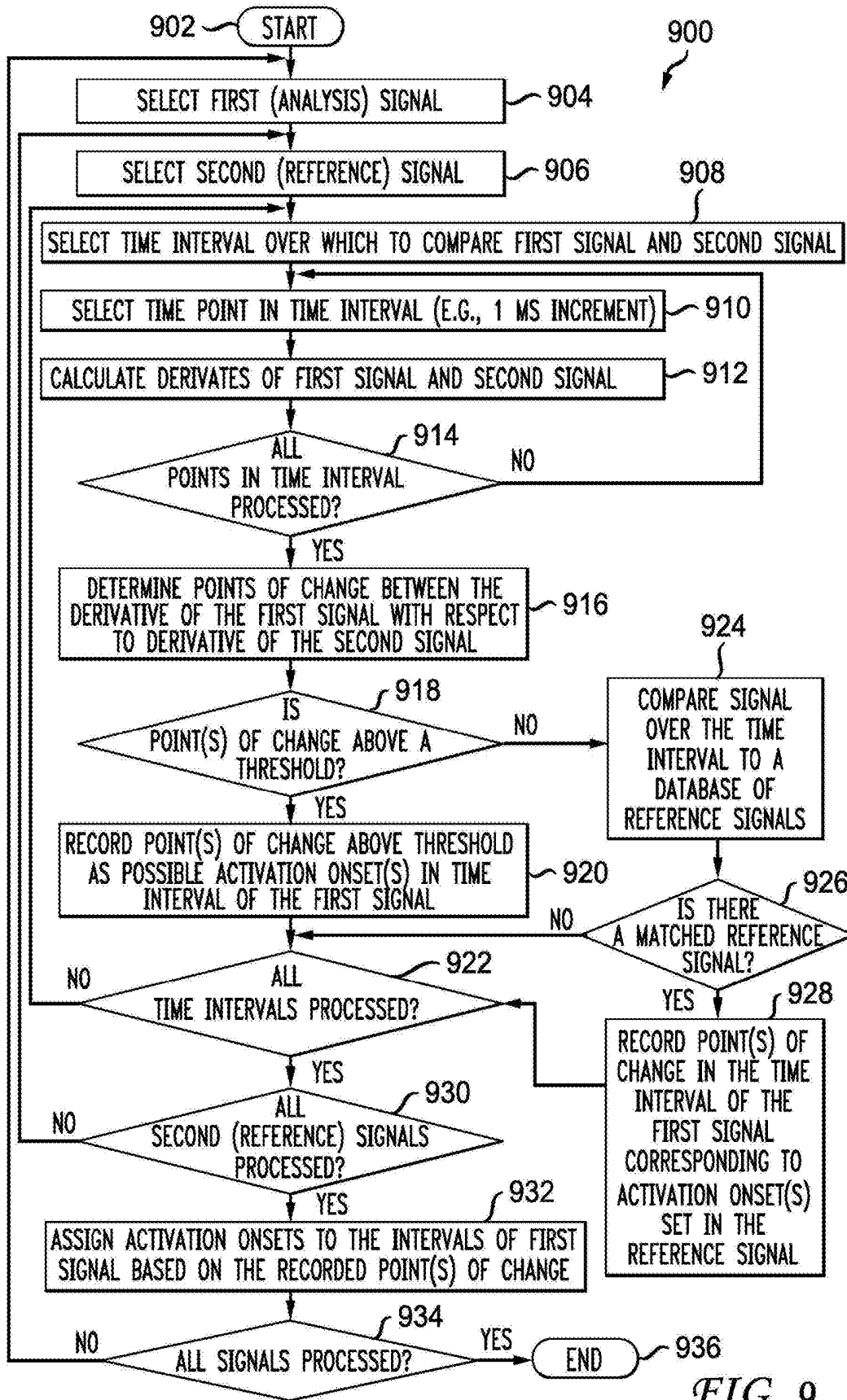

FIG. 9

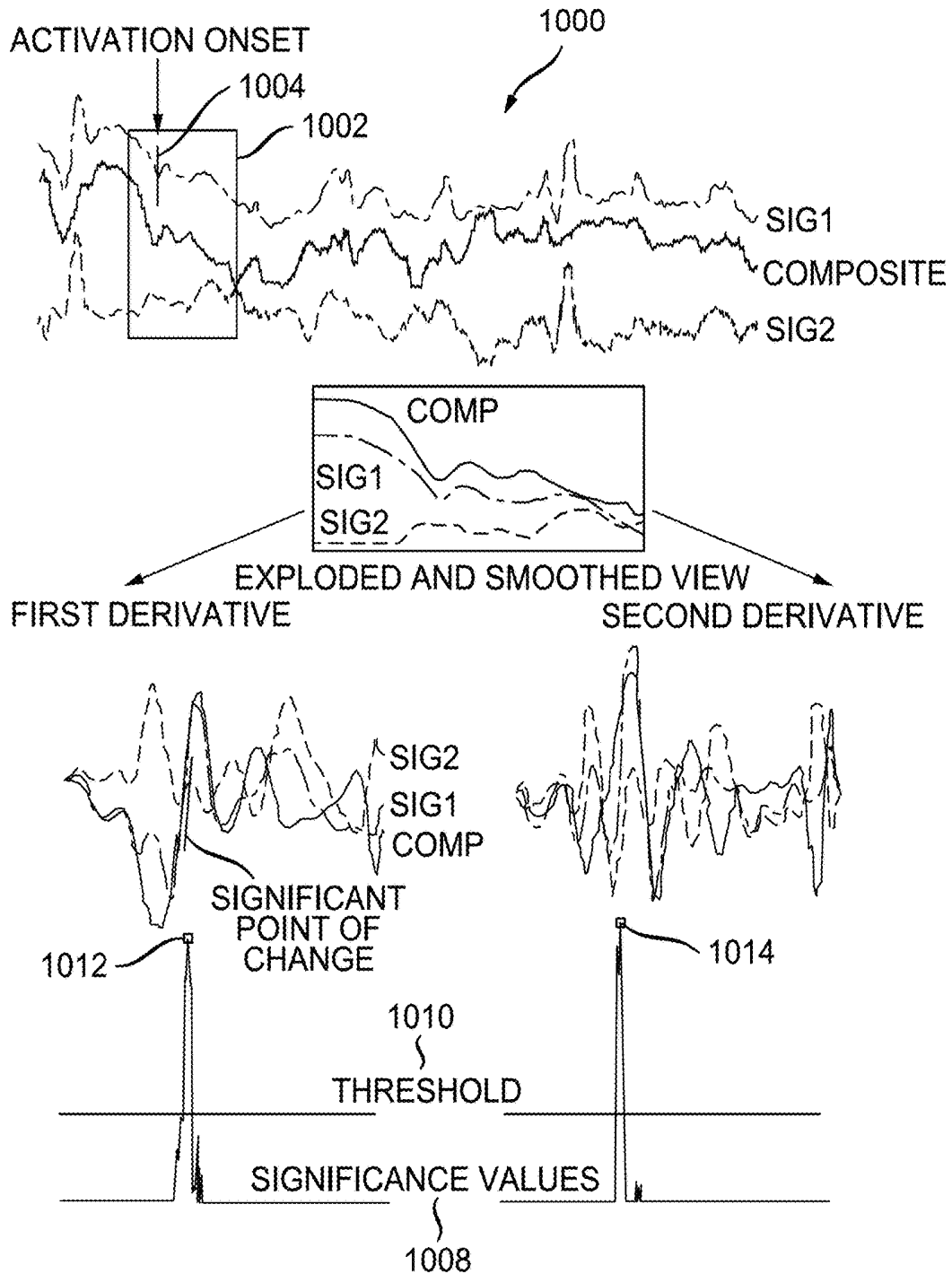

FIG. 10

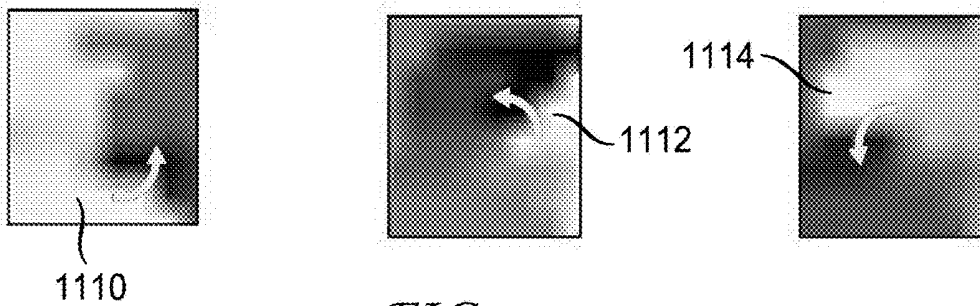
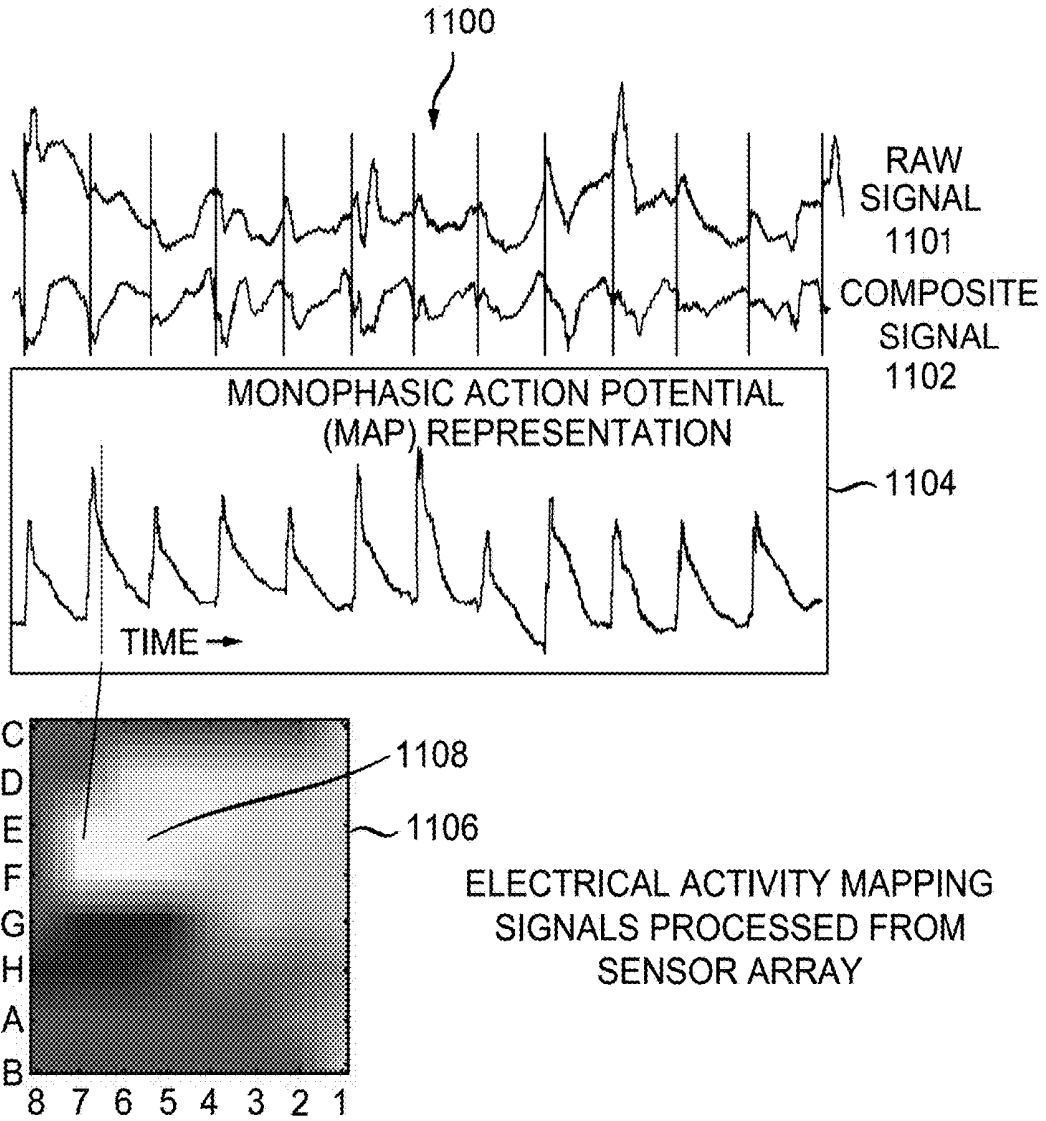
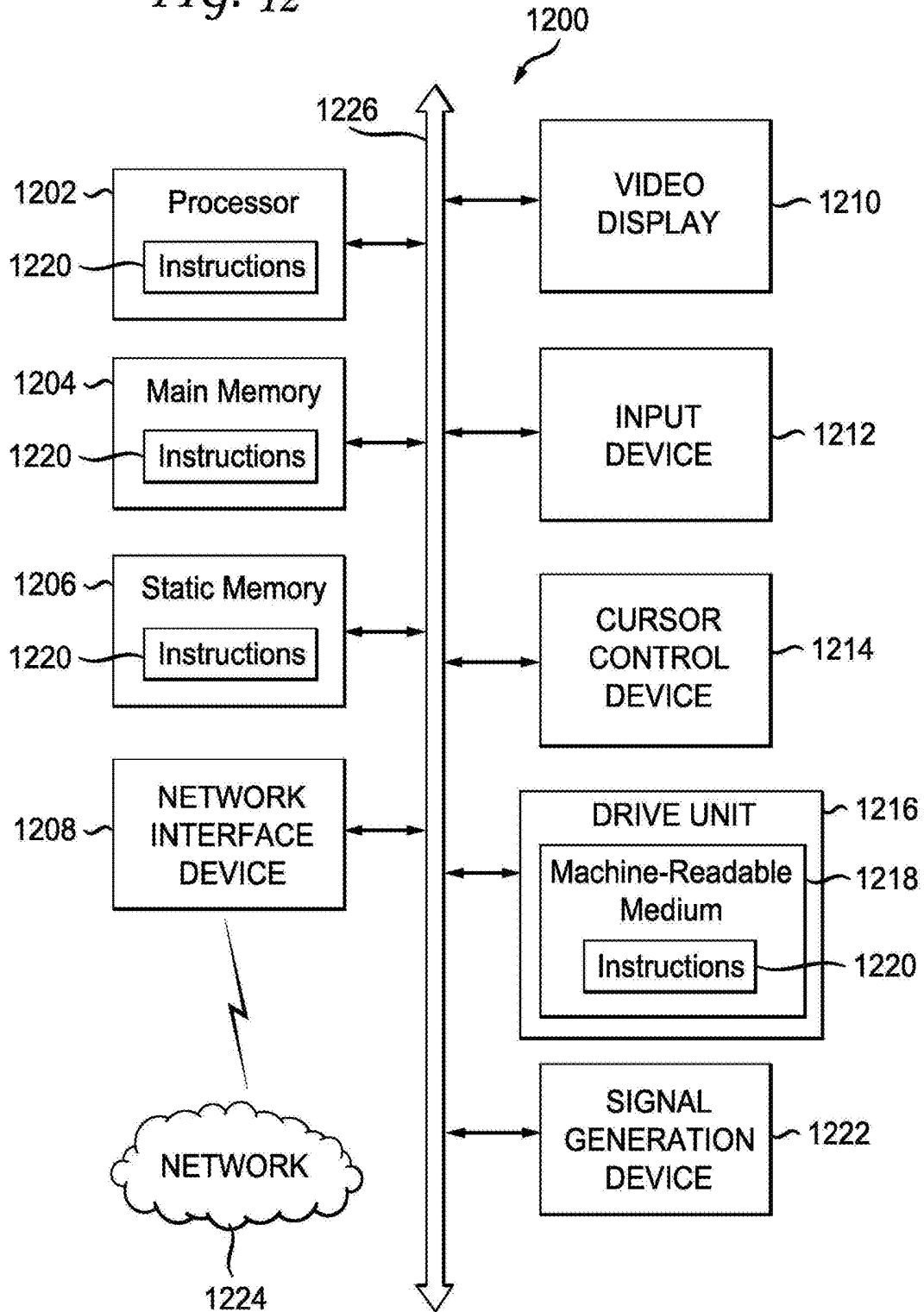

FIG. 11

FIG. 12



## SYSTEM AND METHOD FOR RECONSTRUCTING CARDIAC ACTIVATION INFORMATION

### RELATED APPLICATIONS

This is a continuation of U.S. application Ser. No. 14/724,621, filed May 28, 2015, now U.S. Pat No. 9,468,387, which is a continuation of U.S. application Ser. No. 14/473,905, filed Aug 29, 2014, now U.S. Pat No. 9,055,878, which is a continuation of U.S. application Ser. No. 14/074,619, filed Nov 7, 2013, now U.S. Pat No. 9,055,876, which is a continuation of U.S. application Ser. No. 13/438,534, filed Apr 3, 2012, now U.S. Pat No. 8,594,777, which is a continuation of U.S. application Ser. No. 13/217,123, filed Aug 24, 2011, now U.S. Pat No. 8,165,666, which claims the benefit of the priority of U.S. Provisional Application No. 61/481,607, filed May 2, 2011. Each of the listed applications is incorporated herein by reference in its entirety.

### GOVERNMENT RIGHTS

This invention was made with government support under Grants R01 HL83359, HL83359-S1 and HL103800 awarded by the National Institutes of Health. The government has certain rights in the invention.

### BACKGROUND

#### Field

The present application relates generally to heart rhythm disorders. More specifically, the present application is directed to a system and method for reconstructing cardiac activation information (activation onset) associated with heart rhythm disorders.

#### Brief Discussion of Related Art

Heart (cardiac) rhythm disorders are common and represent significant causes of morbidity and death throughout the world. Malfunction of the electrical system in the heart represents a proximate cause of heart rhythm disorders. Heart rhythm disorders exist in many forms, of which the most complex and difficult to treat are atrial fibrillation (AF), ventricular tachycardia (VT) and ventricular fibrillation (VF). Other rhythm disorders are more simple to treat, but may also be clinically significant including atrial tachycardia (AT), supraventricular tachycardia (SVT), atrial flutter (AFL), supraventricular ectopic complexes/beats (SVE) and premature ventricular complexes/beats (PVC). While under normal conditions the sinus node keeps the heart in sinus rhythm, under certain conditions rapid activation of the normal sinus node can cause inappropriate sinus tachycardia or sinus node reentry, both of which also represent heart rhythm disorders.

Treatment of heart rhythm disorders—particularly complex rhythm disorders of AF, VF and polymorphic VT—can be very difficult. Pharmacologic therapy for complex rhythm disorder is not optimal, with poor efficacy and significant side effects. Ablation has been used increasingly in connection with heart rhythm disorders by maneuvering a sensor/probe to the heart through the blood vessels, or directly at surgery, and delivering energy to a location of the heart that harbors a cause of the heart rhythm disorder to mitigate and in some cases to eliminate the heart rhythm disorder. However, in complex rhythm disorders ablation is often difficult and ineffectual because tools that identify and locate a cause

of the heart rhythm disorder are poor and hinder attempts to deliver energy to the correct region of the heart to eliminate the disorder.

Certain systems and methods are known for treating simple heart rhythm disorders. In a simple heart rhythm disorder (e.g., atrial tachycardia), consistent activation onset patterns from beat to beat can generally be traced back to an earliest location, which can be ablated to mitigate and in some cases to eliminate the disorder. Even in simple heart rhythm disorders, such ablation of the cause of a heart rhythm disorder is challenging and experienced practitioners often require hours to ablate simple rhythm disorders with consistent beat-to-beat activation patterns, such as atrial tachycardia.

There are no known systems and methods that have been successful with respect to identifying causes for the complex rhythm disorders such as AF, VF or polymorphic VT. In a complex rhythm disorder, an earliest location of activation onsets cannot be identified because activation onset patterns change from beat to beat, and are “continuous” such that there is no identifiable earliest point (or start) or latest point (or end).

Diagnosing and treating heart rhythm disorders often involves the introduction of a catheter having a plurality of sensors/probes into the heart through the blood vessels of a patient. The sensors detect electric activity of the heart at sensor locations in the heart. The electric activity is generally processed into electrogram signals that represent the activation of the heart at the sensor locations.

In a simple heart rhythm disorder, the signal at each sensor location is generally consistent from beat to beat in timing and often in shape and number of its deflections, enabling identification of activation onsets at each sensor location. However, in a complex rhythm disorder, the signal at each sensor location from beat to beat may transition between one, several, and multiple deflections of various shapes. For instance, when a signal for a sensor location in AF includes 5, 7, 11 or more deflections, it is difficult, if not impossible, to identify which deflections in the signal are at or near the sensor location in the heart (i.e., local activation) versus a further removed location still sensed by the sensor in the heart (i.e., far-field activation) or simply noise from another part of the patient’s heart, other anatomic structures, movement or motion of the sensor relative to the heart or external electronic systems.

There are no known systems and methods that have been able to reconstruct cardiac activation information (onsets) in variously shaped signals associated with heart rhythm disorders, especially in complex rhythm disorders, to facilitate identification of a cause of the heart rhythm disorders and their elimination.

### SUMMARY

The present invention is applicable to reconstructing activation information of various rhythm disorders, including heart rhythm disorders, as well as other biological rhythm disorders, such as neurological seizures, esophageal spasms, bladder instability, irritable bowel syndrome, and other biological disorders for which biological activation information can be reconstructed to permit determination, diagnosis, and/or treatment of the cause or source of the disorders. It is particularly useful, however, in complex rhythm disorders which result in complex activation patterns, and especially useful in complex rhythm disorders of the heart, in order to find the cause(s) or source(s) of the disorders such that they can be treated with expediency.

Complex heart rhythm disorders typically result in activation patterns that are extremely difficult to decipher and the ability to determine accurate activation information of heartbeats in complex disorders has previously not been possible. Among the advantages of the present invention is the ability to reconstruct cardiac activation information such that a determination of the cause and/or source of the disorder can be determined and treated. Another advantage is that the present invention provides a system and method which can be carried out rapidly while a sensing device—such as a catheter having sensors thereon—is used in or near the patient and can be followed by treatment of cardiac tissue to ameliorate the disorder and in many cases cure the disorder. Treatment may thus occur immediately upon computing the reconstructed cardiac information, since it will provide the location(s) of the cause or source of the disorder.

Prior systems and methods suffered from the inability to determine the source of heart rhythm disorders and consequently provided no means of targeting the source for meaningful and curative treatment. Additionally, prior systems and methods required numerous and complex steps of treatment and yet still failed to provide a means of reconstructing cardiac activation information sufficient to identify the cause(s) or source(s) of the heart rhythm disorder.

In contrast to prior systems and methods, the present invention provides a relatively small number of steps to reconstruct the activation information in order to determine the activation onset times at various sensor locations for a heartbeat amidst the virtually indiscernible activation patterns.

As used herein, “reconstruction” is a process of identifying activation onset time in a cardiac or biological signal at a sensor location distinct from nearby or adjacent sensor locations for one or more beats of a biological or cardiac rhythm disorder.

As used herein, “activation onset time” is a time point at which activation commences in a cell or tissue, as opposed to other time points during activation.

As used herein, “activation” is a process whereby a cell commences its operation from a quiescent (diastolic) state to an active (electrical) state.

In accordance with an embodiment, a method of reconstructing cardiac activation information is disclosed. The method includes accessing pairs of cardiac signals out of a plurality of cardiac signals obtained from a patient. The pairs have a first cardiac signal that is common among the pairs and second cardiac signals that are different among the pairs. The method also includes processing the first cardiac signal and the second cardiac signals of the pairs to identify points of change in the first cardiac signal at which a derivative of the first cardiac signal diverges with respect to derivatives of the second cardiac signals. The method further includes assigning an activation onset time at a point in the first cardiac signal based on correspondence of the points of change to define a cardiac activation indicating a beat.

In some embodiments or aspects, the method can include averaging activation onset times associated with the points of change to determine the activation onset time of the point. In certain embodiments, the selected activation onset times may represent a majority of activation onset times associated with the points of change that are within a predetermined time interval of each other. In other embodiments, the method can include calculating a center-of-mass of activation onset times associated with the points of change weighted by their significance to determine the activation onset time of the point. In still some embodiments, the method can include defining a predominant direction of

activation onset times associated with the points of change relative to sensor locations to determine the activation onset time of the point.

In accordance with another embodiment, a system to reconstruct cardiac activation information is disclosed. The system includes a computing device storing instructions that, when executed by the computing device, cause the computing device to perform certain operations. The operations include accessing pairs of cardiac signals out of a plurality of cardiac signals obtained from a patient. The pairs have a first cardiac signal that is common among the pairs and second cardiac signals that are different among the pairs. The operations also include processing the first cardiac signal and the second cardiac signals of the pairs to identify points of change in the first cardiac signal at which a derivative of the first cardiac signal diverges with respect to derivatives of the second cardiac signals. The operations further include assigning an activation onset time at a point in the first cardiac signal based on correspondence of the points of change to define a cardiac activation indicating a beat.

In some embodiments, the operations can include averaging activation onset times associated with the points of change to determine the activation onset time of the point. In certain embodiments, the selected activation onset times can represent a majority of activation onset times associated with the points of change that are within a predetermined time interval of each other. In other embodiments, the operations can include calculating a center-of-mass of activation onset times associated with the points of change weighted by their significance to determine the activation onset time of the point. In still other embodiments, the operations can include defining a predominant direction of activation onset times associated with the points of change relative to sensor locations to determine the activation onset time of the point.

#### BRIEF DESCRIPTION OF THE DRAWINGS

Some embodiments are illustrated by way of example and not limitation in the figures of the accompanying drawings in which:

FIG. 1 illustrates an example cardiac activation reconstruction system;

FIG. 2 illustrates an example simple electrogram signal of a heart rhythm disorder from a sensor positioned at a sensor location in a heart illustrated in FIG. 1;

FIG. 3 illustrates an example complex electrogram signal of a heart rhythm disorder from a sensor positioned at a sensor location in a heart illustrated in FIG. 1;

FIG. 4 illustrates an example array of sensors of a catheter illustrated in FIG. 1 and an example selection of signals from the sensors to reconstruct cardiac activation information;

FIG. 5 illustrates example comparison pairs of signals from the sensors of the array illustrated in FIG. 4;

FIG. 6 is an illustration of an example signal pair comparison of analysis signal (SIG1) and reference signal (SIG2);

FIG. 7 is an illustration of another example signal pair comparison of analysis signal (SIG1) and reference signal (SIG2);

FIG. 8 is an illustration of a further example signal pair comparison of analysis signal (SIG1) and reference signal (SIG2) utilizing a composite signal;

FIG. 9 is a flowchart that illustrates an example method of reconstructing cardiac activation information associated with heart rhythm disorders;

FIG. 10 is an illustration of an example signal pair comparison of analysis signal (SIG1) and reference signal (SIG2) that can be processed in accordance with the method of FIG. 9 to reconstruct cardiac activation information;

FIG. 11 is an illustration of an example mapping of processed signals in accordance with FIGS. 1-10; and

FIG. 12 is a block diagram of an illustrative embodiment of a general computer system.

#### DETAILED DESCRIPTION

FIG. 1 illustrates an example cardiac activation reconstruction system 100. The example system 100 is configured to detect and reconstruct cardiac activation information collected/detected from a patient's heart in connection with a heart rhythm disorder. The heart includes a right atrium 122, left atrium 124, right ventricle 126 and left ventricle 128.

The example system 100 includes a catheter 102, signal processing device 114, computing device 116 and analysis database 118.

The catheter 102 is configured to detect cardiac activation information in the heart and to transmit the detected cardiac activation information to the signal processing device 114, either via a wireless or wired connection. The catheter includes a plurality of probes/sensors 104, 106, 108, 110 and 112, which can be inserted into the heart through the patient's blood vessels.

In some embodiments, one or more of the sensors 104, 106, 108, 110 and 112 are not inserted into the patient's heart. For example, some sensors may detect cardiac activation via the patient's surface (e.g., electrocardiogram) or remotely without contact with the patient (e.g., magnetocardiogram). As another example, some sensors may also derive cardiac activation information from cardiac motion of a non-electrical sensing device (e.g., echocardiogram). In various embodiments, these sensors can be used separately or in different combinations, and further these separate or different combinations can also be used in combination with sensors inserted into the patient's heart.

The sensors 104, 106, 108, 110 and 112, which are positioned at sensor locations in the heart under consideration, can detect cardiac activation information at the sensor locations and can further deliver energy to ablate the heart at the sensor locations. It is noted that the sensors 104, 106, 108, 110 and 112 can also detect cardiac activation information from overlapping regions of the heart (e.g., right atrium 122 and left atrium 124).

The signal processing device 114 is configured to process (e.g., clarify and amplify) the cardiac activation information detected by the sensors 104, 106, 108, 110 and 112 at the sensor locations into electrogram signals and to provide the processed cardiac signals to the computing device 116 for analysis or processing in accordance with methods disclosed herein. In processing the cardiac activation information from the sensors 104, 106, 108, 110 and 112, the signal processing device 114 can subtract cardiac activation information from overlapping regions of the heart 120 to provide processed cardiac signals to the computing device 116 for analysis. While in some embodiments, the signal processing device 114 is configured to provide unipolar signals, in other embodiments, the signal processing device 114 can provide bipolar signals.

The computing device 116 is configured to receive (or access) cardiac signals from the signal processing device 114 and further configured to analyze or process the cardiac signals in accordance with methods, functions or logic disclosed herein to reconstruct cardiac activation information in the cardiac signals such that it is possible to locate a cause of the heart rhythm disorder and to eliminate the cause.

For example, the computing device 116 can process a first cardiac signal and a second cardiac signal from the received cardiac signals to determine whether there is a point of change in a derivative of the first cardiac signal with respect to a derivative of the second cardiac signal above a threshold. The computing device 116 can then assign an activation onset time in the first signal at the point of change to define cardiac activation indicating a beat in the first signal if it is determined that the point of change is above the threshold.

As another example, the computing device 116 can iteratively select pairs of cardiac signals from the received cardiac signals, each pair having a first cardiac signal and second cardiac signal. The computing device 116 can process and assign for each of the pairs in order to define multiple cardiac activations indicating beats for the first cardiac signal in each of the pairs. For example, the computing device 116 is configured to perform processing and assigning to define multiple cardiac activations indicating beats in the first cardiac signal. The computing device 116 can then reconstruct a cardiac activation pattern based on assigned activation onset times of cardiac activations from the received cardiac signals to indicate a source of a rhythm disorder. In some embodiments, the computing device 116 can also display the reconstructed cardiac activation pattern to facilitate treatment of cardiac tissue at the source to suppress, lessen or eliminate the cardiac rhythm disorder.

The analysis database 118 is configured to support or aid in the analysis of the signals by the computing device 116. In some embodiments, the analysis database 118 can store a catalog of reference signals and associated activations to enable the computing device 116 to determine an activation onset associated with a signal being considered (e.g., when point of change is below threshold during a time window), as will be described in greater detail herein.

FIG. 2 illustrates an example simple electrogram signal 200 of a heart rhythm disorder from a sensor positioned at a sensor location in the heart 120. For example, sensor 104 of catheter 102 can be positioned at a sensor location in the right atrium 122, as shown in FIG. 1. As an example, the heart rhythm disorder can be a complex rhythm disorder AF, VF and polymorphic VT, or another heart rhythm disorder.

The example signal 200 is for a time period between about 300 ms and about 900 ms. During this time period, the signal 200 is expected to have four (4) local activation onsets 204-208, e.g., those activation onsets that originate at or near (local to) the sensor location in the heart 120 of sensor 104. Specifically, based on established observations in heart rhythm disorders, cycle length between activation onsets of about 100 ms to about 300 ms can be expected for AF, and cycle length between activation onsets of about 180 ms to about 240 ms can be expected for complex ventricular arrhythmias. As an example, cycle length 210 of about 100 ms to about 300 is expected between activation onset 202 and activation onset 204. In the example signal 200, the activation onsets 204-208 are generally identifiable as having a small degree of baseline wander superposed in the local signal with few far-field artifacts that could be mistaken as local activity. Local activity in this example can be characterized by an activation onset with a sharp inflection

point and high slope, followed by a period of gentle, low-deviation slope representing repolarization, typically lasting between about 100 ms and 250 ms.

In the example signal **200**, an example far-field deflection **212** is illustrated between location activation onset **206** and local activation onset **208**, e.g., an activation onset that originates at a location in the heart **120** that is different than the sensor location associated with the sensor **104**. Specifically, the heart **120** at the sensor location associated with sensor **104** cannot physiologically activate again after activation onset **206** in a shorter cycle than about 100 ms to about 300 ms because local tissue must undergo repolarization. Moreover, the deflection **212** cannot be local to the sensor location associated with the sensor **104** when the deflection **212** is also significantly present in signals collected by neighbor sensors in multiple directions to sensor **104**. For example, the far-field deflection **212** detected by sensor **104** can be associated with activation onset at a sensor location associated with sensor **106**.

FIG. **3** illustrates an example complex electrogram signal **300** of a heart rhythm disorder from a sensor positioned at a sensor location in the heart **120**. For example, sensor **106** of catheter **102** can be positioned at a sensor location in the right atrium **122**, as shown in FIG. **1**. As an example, the heart rhythm disorder can be a complex rhythm disorder AF, VF and polymorphic VT, or another heart rhythm disorder.

Similarly to example signal **200**, example signal **300** is for a time period between about 300 ms and about 900 ms. During this time period, the signal **300** is expected to have four (4) local activation onsets, e.g., activation onsets that originate locally to the sensor location in the heart **120** of sensor **106**. However, in the example signal **300** there are eleven (11) possible activation onsets **302-322**. Multiple deflections of short duration (shorter than shortest cycle length of about 100 ms) caused by the heart rhythm disorder makes the discernment of local activation onsets at the sensor location of sensor **104** as opposed to far-field activations or simply noise prohibitively difficult.

FIG. **4** illustrates an example array of sensors **400** of catheter **102** and an example selection of signals from the sensors to reconstruct cardiac activation information (e.g., activation onsets). The array **400** includes fifteen (15) example sensors for simplicity and clarity of the description. It is to be understood that the array **400** can include fewer or more sensors to as may be determined to cover different portions of the heart **120**. In some embodiments, the array **400** can include **160** or more sensors.

The sensors of the array **400** are shown in example spatial arrangement with respect to the right atrium **122** of the heart **120**. Similarly, the array **400** can be spatially arranged in other chambers of the heart, e.g., left atrium, right ventricle, left ventricle, or for combinations of chambers including the endocardial or epicardial surfaces. In FIG. **4**, the spatial arrangement of electrodes in the array **400** is shown to be uniform and planar for simplicity and clarity of the description. However, the heart **120** is not a uniform or planar structure. Accordingly, the spatial arrangement of electrodes in the array **400** can be varied with respect to the shape of the heart **120** to improve detection of electric activity in the heart **120**.

In one example embodiment, catheter **102** of FIG. **1** can be a basket catheter with the example sensors of the array **400** disposed in spatial arrangements along splines **406-408** of the basket catheter **102**. Different catheters with various spatial arrangements of the sensors in the sensor array **400** can be used, such as spiral, radial spokes or other spatial arrangements.

Pairs of sensors (signals of sensors) in the array **400** are iteratively selected for processing as will be described in greater detail herein in order to reconstruct cardiac activation information (activation onsets) of the heart **120** in the right atrium **122**, or another chamber in which the array **400** may be disposed.

As illustrated at **402**, an analysis signal (1) is selected for processing. A reference signal (2)—a neighbor to the analysis signal (1)—is then selected to form a first pair that is processed to determine activation onsets in the analysis signal (1). Similarly, as illustrated at **404**, an analysis signal (1) is selected for processing. A reference signal (2)—another neighbor to the analysis signal (1)—is then selected to form a second pair that is processed to determine activation onsets in the analysis signal (1). The activation onsets from the first pair and the second pair of signals can be stored in memory of computing device **116** or database **118** of FIG. **1**. The neighboring sensors (signals) can but do not have to be adjacent, as will be described in greater detail below.

The selections and processing are repeated for the sensors of the array **400** (signals) that neighbor the analysis signal (1). The activation onsets in the analysis signal (1) for all pairs of signals can also be stored in memory of computing device **116** or database **118**. Thereafter, another analysis signal is selected and the selections and processing are repeated for that analysis signal. In this fashion, each of the plurality of analysis signals in array **400** is processed against its neighboring signals. The number of neighboring signals for a given analysis signal can be fewer or greater depending on the spatial arrangement of the sensors in the array **400**, the chamber of the heart analyzed and the heart rhythm disorder treated.

FIG. **5** illustrates example comparison pairs of signals from the sensors of the array **400** illustrated in FIG. **4**. Neighbor signals can include not only those signals that are immediately adjacent to the analysis signal but also those signals not adjacent to the analysis signal. Spatially separating the paired sensors can have the effect of spatially extending the area over which deflections are considered to be local activity. Local activity is therefore approximately defined by the separation of the paired sensors. As illustrated in example 1 of FIG. **5**, selected analysis signal (1) is processed against adjacent signals (2)-(5) and also against a non-adjacent signal (6). As further illustrated in example 2 of FIG. **5**, selected analysis signal (1) is processed against adjacent signals (2)-(5) and also against a non-adjacent signals (6) and (7). While closest neighbor signals are preferred, neighbor signals in various spatial orientations with respect to the analysis signal can be used.

For each analysis signal, there could be a plurality of reference signals (e.g., four (4) or more reference signals). A final activation onset in the analysis signal is determined with reference to or based on the combination of the reference signals' possible activation onsets. Specifically, the activation onsets determined from each pair can be referenced against each other to check for correspondence or association of activations in the analysis signal. An activation onset for the analysis signal is finalized based on the possible activation onsets of the referenced pairs of signals.

The final activation onset for the analysis signal can be determined in various ways. In one embodiment, the final activation onset for the analysis signal can be determined based on an average of the possible activation onsets from the various pairs of referenced signals. In another embodiment, the final activation onset for the analysis signal can be determined based on an average of the possible activation

onsets from those pairs of signals in which a majority of the possible activation onsets are within a predetermined time interval of each other (e.g.,  $\pm 5$  ms). The time interval used can be chosen to be lower or higher. Alternatively, the final activation can also be determined by performing a “center-of-mass” calculation weighted by the significance value of each of the possible activation onsets in the majority, or by analysis of a predominant direction of activation onsets relative to sensor locations.

With reference to example 1 in FIG. 5, if an analysis signal has been determined to have possible activation onsets of 170 ms, 190 ms, 193 ms, 165 ms and 172 ms in connection with the five (5) reference signal pairs, respectively, then the final activation onset for the analysis signal can be determined to be  $(170+165+172)/3=169$  ms. The activation onsets of 190 ms and 193 ms that are outside the time interval can be discounted from the determination of the final activation onset for the analysis signal. The final activation onset determined for each signal can be saved in the database 118 of FIG. 1.

While in the forgoing examples for the sake of brevity and clarity, only one activation onset was determined for the analysis signal in connection with each reference signal, it should be understood that each signal (from a sensor of array 400) can represent multiple successive analysis intervals (e.g., activation cycles) as illustrated in FIG. 2, each of which can have an activation onset as determined based on the same time interval of multiple reference signals (neighboring sensors of array 400).

FIG. 6 is an illustration of an example signal pair comparison 600 of example analysis signal (SIG1) and example reference signal (SIG2). For example, the signals can be from comparison pair 402 (or comparison pair 404) illustrated in FIG. 4, or from any comparison pair illustrated in FIG. 5. It is noted that the signals are illustrative and occur during the same analysis interval. As noted herein, the signals can have multiple successive analysis intervals (e.g., activation cycles), as illustrated in FIG. 2.

The signals are processed at one or more successive time points (e.g., every millisecond, two milliseconds, or other time points) to determine whether there is a point of change in a derivative of the analysis signal with respect to a derivative of the reference signal above a threshold. The point of change can be determined from one or more of slope, amplitude, timing and shape for the first cardiac signal and the second cardiac signal. It should be noted that in some embodiments, processing of some time points can be omitted (e.g., every other time point or two of three time points). A first derivative (or second derivative) is determined for each of the time points in the signals. A root mean squared is determined for each of the signals. For example, RMS1 and RMS2 are determined by taking a root mean squared of the derivatives for the entire signal of each of the signals (e.g., all activation cycles). RMS can be used to normalize the amplitude of the signals with respect to one another, such that amplitudes (e.g., voltage) of the deflections in the signals do not affect the processing of the signals as described below.

A time point (same time point or about the same time point) is successively selected from each of the signals (SIG1, SIG2) for consideration and processing. For each time point under consideration, a time increment 602, 604 in each signal starting at that time point can be considered. For example, a time increment of 10 ms can be used. Different time increments can be selected. A line which is pinned to the point under consideration in each signal and which provides the best fit to the time points in the time increment

of each signal is determined. The determined lines represent the slopes (e.g., volts/per second) of the signals for the selected time point. More specifically, the determined lines represent slopes of the signals at the selected time point for the same time increment (e.g., 10 ms). A significance value ( $\delta$ ) is determined with respect to the slopes.

The significance value can be determined by taking an absolute value of the first slope over its associated root mean squared value and subtracting an absolute value of the second slope over its associated root mean squared value. A determination is made as to whether the resulting ( $\delta$ )=0.461 is above a significance threshold (e.g., 0.25). The significance threshold indicates that there is a potentially significant point of change (based on slopes) for the time point in the signals under consideration, e.g., that the derivatives diverge sufficiently from each other. In the example signal pair comparison 600, the significance value ( $\delta$ )=0.461 is below the significance threshold of 0.25. The low significance value indicates that the deflection in SIG1 is far-field and not sufficiently local to a sensor location from which the signal originated, e.g., a sensor shown in FIG. 4. Accordingly, there is no potentially significant point of change in the example signal pair comparison 600.

As noted herein, the signals can have multiple successive analysis intervals (e.g., activation cycles), as illustrated in FIG. 2. In each analysis interval, it is possible to have zero, one or more potentially significant points of change as described above. The time point under consideration and the potentially significant point(s) of change can be recorded, such as in database 118.

FIG. 7 is an illustration of an example signal pair comparison 700 of example analysis signal (SIG1) and example reference signal (SIG2). Similarly, the signals can be from comparison pair 402 (or comparison pair 404) illustrated in FIG. 4, or from any comparison pair illustrated in FIG. 5. The signals are illustrative and occur during the same analysis interval. As noted herein, the signals can have multiple successive analysis intervals (e.g., activation cycles), as illustrated in FIG. 2.

The signals are processed at one or more successive time points to determine whether there is a point of change in a derivative of the analysis signal with respect to a derivative of the reference signal above a threshold. In some embodiments, processing of some of the time points can be omitted (e.g., every other time point or two of three time points). A first derivative (or second derivative) is determined for each of the time points in the signals. A root mean squared is further determined for each of the signals. A time point (same time point or about the same time point) is successively selected from each of the signals (SIG1, SIG2) for consideration and processing. For each time point under consideration, a time increment 702, 704 (e.g., 10 ms) in each signal starting at that time point can be considered. A line which is pinned to the point under consideration in each signal and which provides the best fit to the time points in the time increment of each signal is determined. The determined lines represent the slopes (e.g., volts/per second) of the signals for the selected time point. More specifically, the determined lines represent the slopes at the selected time point for the same time increment. A significance value ( $\delta$ ) is determined with respect to the slopes.

The significance value can be determined by taking an absolute value of the first slope over its associated root mean squared value and subtracting an absolute value of the second slope over its associated root mean squared value. A determination is made as to whether the resulting ( $\delta$ )=0.063 is above a significance threshold (e.g., 0.25). In the

example signal pair comparison **700**, the significance value ( $\delta$ )=-0.063 is well below the significance threshold of 0.25. The low significance value indicates low amplitude noise. Accordingly, there is no potentially significant point of change in the example signal pair comparison **700**.

A noise level can be defined as fraction of the significance threshold or can be defined programmatically in various ways. For example, noise level can be one-tenth (0.025) of the significance threshold (0.25). A different fraction level can be selected. As another example, the noise level can be defined as a Gaussian standard deviation of a plurality of significance values. Other ways of defining the noise level are contemplated. It is noted that the significance threshold (e.g., 0.25) is higher than the noise level that can be associated with the analysis signal and reference signal in the example signal pair comparison **700**. Accordingly, a point of change at or below noise level can be associated with one or more signals from other regions of a heart, respiratory system, gastrointestinal tract, neurological system as well as electronic interference.

As noted herein, the signals can have multiple successive analysis intervals (e.g., activation cycles) and in each analysis interval, it is possible to have zero, one or more potentially significant points of change as described above. The time point under consideration and the potentially significant point(s) of change can be recorded, such as in database **118**.

FIG. **8** is an illustration of an example signal pair comparison **800** of example analysis signal (SIG1) and example reference signal (SIG2) utilizing a composite signal. As in the other examples, the signals can be from comparison pair **402** (or comparison pair **404**) illustrated in FIG. **4**, or from any comparison pair illustrated in FIG. **5**. The signals are illustrative and occur during the same analysis interval. As noted herein, the signals can have multiple successive analysis intervals (e.g., activation cycles), as illustrated in FIG. **2**.

The signals are processed at one or more successive time points to determine whether there is a point of change in a derivative of the analysis signal with respect to a derivative of the reference signal above a threshold. In some embodiments, processing of some of the time points can be omitted (e.g., every other time point or two of three time points). A first derivative (zero order derivative or second derivative) is determined for each of the time points in the signals. A root mean squared is further determined for each of the signals. A time point (same time point or about the same time point) is successively selected from each of the signals (SIG1, SIG2) for consideration and processing. For each time point under consideration, a time increment **802**, **804** (e.g., 10 ms) in each signal starting at that time point can be used. A line which is pinned to the point under consideration in each signal and which provides the best fit to the time points in the time increment of each signal is determined. The determined lines represent the slopes (e.g., volts/per second) of the signals for the selected time point. More specifically, the determined lines represent the slopes of the signals at the selected time point for same time increment. A significance value ( $\delta$ ) is determined with respect to the slopes.

In some embodiments, the significance value can be determined by taking an absolute value of the first slope over its associated root mean squared value and subtracting an absolute value of the second slope over its associated root mean squared value. A determination is made as to whether the resulting ( $\delta$ )=0.546 is above a significance threshold (e.g., 0.25). In the example signal pair comparison **800**, the significance value ( $\delta$ )=0.546 is determined to be above the significance threshold of 0.25.

Accordingly, there is a potentially significant point of change in the example signal pair comparison **800** at the time point under consideration. As noted herein, the signals can have multiple successive analysis intervals (e.g., activation cycles) and in each analysis interval, it is possible to have zero, one or more potentially significant points of change as described above. The time point under consideration and the potentially significant point(s) of change can be recorded, such as in database **118**.

In other embodiments, the significance value can be determined with respect to a composite signal. Specifically, a composite signal (COMP) is computed by subtracting SIG2 (reference signal) from SIG1 (analysis signal), e.g., COMP=SIG2-SIG1. The composite signal can represent a bipolar signal (COMP) of constituent unipolar signals (SIG1, SIG2). In alternate embodiments, the composite signal COMP can also be computed by adding signals SIG1 and SIG2. The signals in the signal pair comparison **800** are illustrative and occur during the same analysis interval. As noted herein, the signals can have multiple successive analysis intervals (e.g., activation cycles), as illustrated in FIG. **2**.

The signals SIG1, SIG2 are processed at one or more successive time points with respect to the composite signal COMP to determine whether there is a point of change in a derivative of the analysis signal with respect to a derivative of the reference signal above a threshold. A first derivative (or second derivative) is determined for each of the time points in the signals SIG1, SIG2, COMP. A time point (same time point or about the same time point) is successively selected from each of the signals (SIG1, SIG2, COMP) for consideration and processing. For each time point under consideration, a time increment **802**, **804**, **806** (e.g., 10 ms) in each signal starting at that time point can be considered. A line which is pinned to the point under consideration in each signal and which provides the best fit to the time points in the time increment of each signal is determined. The determined lines represent the slopes (e.g., volts/per second) of the signals for the selected time point. More specifically, the determined lines represent the slopes of the signals at the selected time point for the same time increment. A significance value ( $\delta$ ) is determined with respect to the slopes.

In embodiments that employ the composite signal, the significance value ( $\delta$ ) can be determined by a ratio taking an absolute value of the second slope and subtracting an absolute value of the composite slope, and dividing by a logarithm of a result of an absolute value the first slope subtracting an absolute value of the composite slope. The resulting significance value for the time point under consideration is ( $\delta$ )=31.63. Significance values can be computed for all points under consideration. A significance threshold can be determined to be an average of the computed significance values ( $\delta$ ) plus a standard deviation. Thereafter, only those significance values ( $\delta$ ) that are above the significance threshold can be considered to be potentially significant points of change for the comparison pair **800**. For the example signals in the signal pair comparison **800** of FIG. **8**, the determined significance threshold can be 10. It is noted that the significance value(s) that is above the significance threshold generally extends substantially above the significance threshold. For example, a significance value ( $\delta$ )—having the largest ratio—can therefore be selected.

Accordingly, there is a potentially significant point of change in the example signal pair comparison **800** at the time point under consideration. As noted herein, the signals can have multiple successive analysis intervals (e.g., activation cycles) and in each analysis interval, it is possible to have zero, one or more potentially significant points of

change as described above. The time point under consideration and the potentially significant point(s) of change can be recorded, such as in database 118.

FIG. 9 is a flowchart that illustrates an example method 900 of reconstructing cardiac activation information (activation onset) associated with heart rhythm disorders. The example method 900 can be performed by the computing device 116 illustrated in FIG. 1. More specifically, the example method 900 starts at operation 902 at which signals are received by the computing device 116 via signal processing device 114 from sensors disposed in the heart 120. For example, signals can be received from sensors of the sensor array 400 disposed in the right atrium 122 of the heart 120, as shown in FIGS. 1 and 4. In some embodiments, at least a portion of the signals from the sensors can be recorded by signal processing device 114 and then provided to computing device 116.

At operation 904, a first signal (analysis signal) is selected. At operation 906, a second signal (reference signal) is selected. Selection of the analysis signal and the reference signal can be performed as described in greater detail with reference to FIGS. 4 and 5. In some embodiments, a root mean squared (RMS) can be determined for the first signal and for the second signal. At operation 908, a time interval over which the first signal and the second signal are to be compared is selected. The time interval can be selected to be an activation cycle (e.g., 100 ms to 300 ms) as described in FIG. 2. In some embodiments, the time interval can be determined by a dominant frequency analysis or other analysis of the average cycle length of the first (analysis) signal. A default time interval of 200 ms can be used if the time interval cannot be determined computationally. In other embodiments, the time interval can be selected manually, computationally by a different analysis method, from a database that catalogs such time intervals for patients of a certain age, gender and type of heart rhythm disorder, or defaulted to a value between about 100 ms and about 300 ms.

In some embodiments, a composite signal can be determined based on the selected first signal and the second signal, such as by subtracting or adding the signals as described with reference to FIG. 8.

At operation 910, a time point is selected for consideration in the selected time interval. The same or about the same time point is selected for consideration in each signal (e.g., first signal and second signal). At operation 912, derivatives are calculated for a time increment (e.g., 10 ms) extending from the point of consideration in each signal. In embodiments that use a composite signal, a derivative is also calculated for a time increment (e.g., 10 ms) extending from a time point of consideration in the composite signal. The time point of consideration in the composite signal is the same or about the same as in the other signals (e.g., first signal and second signal).

At operation 914, a determination is made as to whether all points in the selected time interval have been processed. If it is determined that all points in the selected time interval were processed, the method 900 continues at operation 916. Alternatively, the method 900 performs operations 910, 912 until all points in the selected time interval are determined to be processed at operation 914.

At operation 916, points of change between the derivatives of the first signal with respect to the derivatives of the second signal are determined in the time interval under consideration. For example, a significance value ( $\delta$ ) can be determined at each point of change as described with reference to FIGS. 6-8.

At operation 918, a determination is made as to whether there is a point(s) of change in the derivative of the first cardiac signal with respect to the derivative of the second cardiac signal above a threshold. For example, it can be determined whether the significance value ( $\delta$ ) at the point of change is above the threshold. In embodiments that do not use a composite signal, the threshold can be 0.25 (or another value) as described with reference to FIGS. 6-8, while in the embodiments that do use a composite signal, the threshold can be computed as an average value plus a standard deviation of all points of change as described with reference to FIG. 8.

If it is determined that there is a point(s) of change above the threshold, the method 900 continues at operation 920 where the significant point(s) of change is recorded (selected) as a possible activation onset(s) for the time interval under consideration in the first (analysis) signal. If however, it is determined that there is no point of change above the threshold (no significant point of change), the method 900 continues at operation 924 where the first signal is compared over the time interval to a catalog of reference signals. For example, the catalog of reference signals for heart rhythm disorders can be maintained in database 118. At operation 926, a determination is made as to whether there is a match to a reference signal in the database. The comparison can be based on at least one characteristic of the first signal to at least one characteristic of the reference signal, such as shape, slope, amplitude, frequency and/or timing. Other characteristics can be used together with or instead of the enumerated characteristics.

If there is no match to a reference signal at operation 926, the method 900 continues at operation 922. Alternatively, the method 900 continues at operation 928 where the point(s) of change in the time interval under consideration is recorded (selected), which would correspond to activation onset(s) in the reference signal that was matched.

At operation 922, a determination is made as to whether all time intervals in the signals have been processed. If it is determined that all time intervals have not been processed, the method 900 continues to perform operations 908-922 to process subsequent time intervals until it is determined that all time intervals have been processed. The subsequent time interval can be determined from the point(s) of change that represents the possible activation onset at 920. Specifically, if only one point of change (above the threshold) is recorded at 920, then the next time interval (e.g., 100 ms to 300 ms) starts at the onset time associated with the point of change plus a half of a cycle length (e.g., 50 ms to 150 ms). If there are multiple points of change, then the onset time associated with the largest point of change (significance value) is used to determine the next time interval for operations 908-922. It is noted that the determination of the next time interval can be extended to consider significant points of change from all second (reference) signals for the same time interval under consideration. However, if it is determined that all time intervals have been processed at operation 922, the method 900 continues at operation 930.

At operation 930, a determination is made as to whether all second (reference) signals have been processed in association with the selected first (analysis) signal. If it is determined that all second signals have not been processed, the method 900 continues to perform operations 906-930 until it is determined that all second (reference) signals have been processed for the first (analysis) signal. However, if it is determined that all second signals have been processed, the method 900 continues to operation 932.

At operation **932**, an activation onset(s) is assigned in the first signal at the point(s) of change to define cardiac activation(s) indicating a beat(s) in the first signal if it is determined (at operation **918**) that the point(s) of change is above the threshold. Similarly, at operation **932** an activation onset(s) can be assigned in the first signal at the point(s) of change to define cardiac activation(s) indicating a beat(s) in the first signal based on a matched reference signal (at operation **928**). More specifically, activation onsets are assigned to the time intervals of the first signal based on the recorded (or significant) point(s) of change of the first signal with reference to the second signal(s). That is, an activation onset is assigned to each time interval in the first (analysis) signal based possible activation onset(s) associated with the significant point(s) of change in the same time interval of the second (reference) signal(s). As described with reference to FIG. 5, the activation onset for the time interval of the first (analysis) signal can be determined based on an average of the activation onsets with reference to the second (reference) signals. In another embodiment, the activation onset for the time interval of the first signal can be determined based on an average of activation onsets with reference to those second signals in which a majority of activation onsets are within a predetermined time interval of each other (e.g.,  $\pm 5$  ms). The assigned onset can be recorded for each interval in the first (analysis) signal such as in database **118**.

At operation **934**, a determination is made as to whether all signals have been processed or analyzed as first (analysis) signals against second (reference) signals. If it is determined that all signals have not been processed, then the method **900** continues to perform operations **904-932** until all signals have been processed. Alternatively, if it is determined that all signals have been processed, the method **900** ends at operation **936**.

At the conclusion of the method **900**, signals collected from the heart **120** have been reconstructed with cardiac activation information (activation onsets) such that a cause of the heart rhythm disorder can be determined. More specifically, unipolar electrograms or monophasic action potentials (MAPs) can be mapped to the reconstructed activation onsets of the signals to show unipolar or MAP sequences or representations for the signals. An activation map or pattern can be constructed from these unipolar voltage or MAP voltage representations of the signals to locate the cause of the heart rhythm disorder. An example MAP representation and example activation map are illustrated in FIG. **11**.

FIG. **10** is an illustration of an example signal pair comparison **1100** of analysis signal (SIG1) and reference signal (SIG2) that can be processed in accordance with method **900** of FIG. **9** to assign an activation onset **1004**. As illustrated in comparison **1100**, a time interval **1002** (e.g., 100 ms-300 ms) is selected for comparison and processing. In some example embodiments, the signals in the time interval (SIG1, SIG2, COMP) are smoothed, such as via median filter. Significance values ( $\delta$ ) are determined for the points of changes in the signals' first or second derivative, as described herein with reference to FIGS. **1-9**. As illustrated in signal pair comparison **1100**, point of change **1012** in SIG1 that is above threshold **1010** is assigned as the activation onset **1004** for the time interval **1002** in SIG1 based on the first derivative. Alternatively, point of change **1014** in SIG1 that is above threshold **1010** is assigned as the activation onset **1004** for the time interval **1002** in SIG1 based on the second derivative. Subsequent time intervals

are selected and activation onsets are assigned as described herein with reference to FIGS. **1-9** until the analysis signal (SIG1) is processed.

FIG. **11** is an illustration of an example mapping **1000** of processed signals in accordance with FIGS. **1-10**. Raw signal **1101** represents a signal that is processed to assign activation onsets (vertical lines) as described herein. For reference purposes, a composite signal **1102** is shown, which results from the raw (analysis) signal **1101** and another (reference) signal (not shown). A monophasic action potential (MAP) voltage representation is generated for each processed signal **1101**. Multiple signals are processed as described herein and MAPs generated based on the processed signals. The electrical activity of all MAPs is mapped in a sequence of example activation mappings **1106** to show activation onsets **1108**, **1110**, **1112** and **1114** at each time interval, respectively. These mappings can be displayed by computing device **116**. Although only four mapping are shown for illustrative purposes, there can be fewer or greater number of mappings **1106** based on the time intervals represented in the signals.

As shown by the arrows in the example mappings **1106** (e.g., activation onsets **1108**, **1110**, **1112** and **1114**), the electrical activity indicates a rotational activation pattern of activation onsets (rotor) in the heart rhythm disorder. At least a portion of the area of the heart **120** indicated by the rotational activation pattern indicated by the arrows in FIG. **11** can be treated to eliminate the cause of the heart rhythm disorder, and therefore the heart rhythm disorder itself. Such treatment may be delivered by ablation using various energy sources (including but not limited to radiofrequency, cryoenergy, microwave, and ultrasound), gene therapy, stem cell therapy, pacing stimulation, drug or other therapy. It is noted that the MAP representation and activation map are examples to illustrate a rotational activation pattern. Other activation patterns can result from different example signals collected by the sensors from the heart **120**.

FIG. **12** is a block diagram of an illustrative embodiment of a general computer system **1200**. The computer system **1200** can be the signal processing device **114** and the computing device **116** of FIG. **1**. The computer system **1200** can include a set of instructions that can be executed to cause the computer system **1200** to perform any one or more of the methods or computer based functions disclosed herein. The computer system **1200**, or any portion thereof, may operate as a standalone device or may be connected, e.g., using a network or other connection, to other computer systems or peripheral devices. For example, the computer system **1200** may be operatively connected to signal processing device **114** and analysis database **118**.

The computer system **1200** may also be implemented as or incorporated into various devices, such as a personal computer (PC), a tablet PC, a personal digital assistant (PDA), a mobile device, a palmtop computer, a laptop computer, a desktop computer, a communications device, a control system, a web appliance, or any other machine capable of executing a set of instructions (sequentially or otherwise) that specify actions to be taken by that machine. Further, while a single computer system **1200** is illustrated, the term "system" shall also be taken to include any collection of systems or sub-systems that individually or jointly execute a set, or multiple sets, of instructions to perform one or more computer functions.

As illustrated in FIG. **12**, the computer system **1200** may include a processor **1202**, e.g., a central processing unit (CPU), a graphics-processing unit (GPU), or both. Moreover, the computer system **1200** may include a main memory

1204 and a static memory 1206 that can communicate with each other via a bus 1226. As shown, the computer system 1200 may further include a video display unit 1210, such as a liquid crystal display (LCD), an organic light emitting diode (OLED), a flat panel display, a solid state display, or a cathode ray tube (CRT). Additionally, the computer system 1200 may include an input device 1212, such as a keyboard, and a cursor control device 1214, such as a mouse. The computer system 1200 can also include a disk drive unit 1216, a signal generation device 1222, such as a speaker or remote control, and a network interface device 1208.

In a particular embodiment, as depicted in FIG. 12, the disk drive unit 1216 may include a computer-readable medium 1218 in which one or more sets of instructions 1220, e.g., software, can be embedded. Further, the instructions 1220 may embody one or more of the methods or logic as described herein. In a particular embodiment, the instructions 1220 may reside completely, or at least partially, within the main memory 1204, the static memory 1206, and/or within the processor 1202 during execution by the computer system 1200. The main memory 1204 and the processor 1202 also may include computer-readable media.

In an alternative embodiment, dedicated hardware implementations, such as application specific integrated circuits, programmable logic arrays and other hardware devices, can be constructed to implement one or more of the methods described herein. Applications that may include the apparatus and systems of various embodiments can broadly include a variety of electronic and computer systems. One or more embodiments described herein may implement functions using two or more specific interconnected hardware modules or devices with related control and data signals that can be communicated between and through the modules, or as portions of an application-specific integrated circuit. Accordingly, the present system encompasses software, firmware, and hardware implementations.

In accordance with various embodiments, the methods described herein may be implemented by software programs tangibly embodied in a processor-readable medium and may be executed by a processor. Further, in an exemplary, non-limited embodiment, implementations can include distributed processing, component/object distributed processing, and parallel processing. Alternatively, virtual computer system processing can be constructed to implement one or more of the methods or functionality as described herein.

It is also contemplated that a computer-readable medium includes instructions 1220 or receives and executes instructions 1220 responsive to a propagated signal, so that a device connected to a network 1224 can communicate voice, video or data over the network 1224. Further, the instructions 1220 may be transmitted or received over the network 1224 via the network interface device 1208.

While the computer-readable medium is shown to be a single medium, the term "computer-readable medium" includes a single medium or multiple media, such as a centralized or distributed database, and/or associated caches and servers that store one or more sets of instructions. The term "computer-readable medium" shall also include any medium that is capable of storing, encoding or carrying a set of instructions for execution by a processor or that cause a computer system to perform any one or more of the methods or operations disclosed herein.

In a particular non-limiting, example embodiment, the computer-readable medium can include a solid-state memory, such as a memory card or other package, which houses one or more non-volatile read-only memories. Further, the computer-readable medium can be a random access

memory or other volatile re-writable memory. Additionally, the computer-readable medium can include a magneto-optical or optical medium, such as a disk or tapes or other storage device to capture carrier wave signals, such as a signal communicated over a transmission medium. A digital file attachment to an e-mail or other self-contained information archive or set of archives may be considered a distribution medium that is equivalent to a tangible storage medium. Accordingly, any one or more of a computer-readable medium or a distribution medium and other equivalents and successor media, in which data or instructions may be stored, are included herein.

In accordance with various embodiments, the methods described herein may be implemented as one or more software programs running on a computer processor. Dedicated hardware implementations including, but not limited to, application specific integrated circuits, programmable logic arrays, and other hardware devices can likewise be constructed to implement the methods described herein. Furthermore, alternative software implementations including, but not limited to, distributed processing or component/object distributed processing, parallel processing, or virtual machine processing can also be constructed to implement the methods described herein.

It should also be noted that software that implements the disclosed methods may optionally be stored on a tangible storage medium, such as: a magnetic medium, such as a disk or tape; a magneto-optical or optical medium, such as a disk; or a solid state medium, such as a memory card or other package that houses one or more read-only (non-volatile) memories, random access memories, or other re-writable (volatile) memories. The software may also utilize a signal containing computer instructions. A digital file attachment to e-mail or other self-contained information archive or set of archives is considered a distribution medium equivalent to a tangible storage medium. Accordingly, a tangible storage medium or distribution medium as listed herein, and other equivalents and successor media, in which the software implementations herein may be stored, are included herein.

A system and method to reconstruct cardiac activation information have been described. Although specific example embodiments have been described, it will be evident that various modifications and changes may be made to these embodiments without departing from the broader scope of the invention. Accordingly, the specification and drawings are to be regarded in an illustrative rather than a restrictive sense. The accompanying drawings that form a part hereof, show by way of illustration, and not of limitation, specific embodiments in which the subject matter may be practiced. The embodiments illustrated are described in sufficient detail to enable those skilled in the art to practice the teachings disclosed herein. Other embodiments may be utilized and derived therefrom, such that structural and logical substitutions and changes may be made without departing from the scope of this disclosure. This Detailed Description, therefore, is not to be taken in a limiting sense, and the scope of various embodiments is defined only by the appended claims, along with the full range of equivalents to which such claims are entitled.

Embodiments may be referred to herein, individually and/or collectively, by the term "invention" merely for convenience and without intending to voluntarily limit the scope of this application to any single invention or inventive concept if more than one is, in fact, disclosed. Thus, although specific embodiments have been illustrated and described herein, it should be appreciated that any arrangement calculated to achieve the same purpose may be sub-

stituted for the specific embodiments shown. This disclosure is intended to cover any and all adaptations or variations of various embodiments. Combinations of the above embodiments, and other embodiments not specifically described herein, will be apparent to those of skill in the art upon reviewing the above description. 5

The Abstract is provided to comply with 37 C.F.R. § 1.72(b) and will allow the reader to quickly ascertain the nature and gist of the technical disclosure. It is submitted with the understanding that it will not be used to interpret or limit the scope or meaning of the claims. 10

The invention claimed is:

1. A system to generate an output map of successive cardiac signals comprising:

at least one computing device configured to: 15

determine values for each of a plurality of points associated with cardiac signal data for a given spatial region of tissue, the values corresponding to electrical information for each respective point of the plurality of points within a plurality of time intervals; 20

process the values for each of the plurality of points within a first time interval of the plurality of time intervals to generate a first map;

process the values for each of the plurality of points within one or more successive time intervals of the plurality of time intervals to generate one or more successive maps; 25

compare the processed values within the first time interval and the one or more successive time intervals relative to reference signals in a database to identify activation onsets within the plurality of time intervals; and 30

generate an output map of successive cardiac signals for the given spatial region of tissue based on the compared processed values, the output map comprising a clinical representation of activation patterns within the given spatial region of tissue. 35

2. The system of claim 1, wherein the output map identifies a source of a cardiac rhythm disorder.

3. The system of claim 2, wherein the source is rotational. 40

4. The system of claim 2, wherein the source is a rotor.

5. A method for generating an output map of successive cardiac signals to indicate a source of a complex cardiac rhythm disorder, comprising:

determining values for each of a plurality of points associated with cardiac signal data for a given spatial region of tissue, the values associated with electrical information for each respective point of the plurality of points within a plurality of time intervals; 45

processing the values for each of the plurality of points within a first time interval to generate a first map; 50

processing the values for each respective point of the plurality of points one or more successive time intervals to generate one or more successive maps;

comparing the first map and the one or more successive maps relative to reference signals in a database to identify activation onsets; and

generating an output map of successive cardiac signals for the given spatial region of tissue based on the compared maps, the output map comprising a clinical representation indicative of the source of the complex rhythm disorder in the given spatial region of tissue.

6. The method of claim 5, further comprising treating cardiac tissue at the source in order to suppress or eliminate the cardiac rhythm disorder.

7. The method of claim 6, wherein treating the cardiac tissue is by ablation.

8. The method of claim 7, wherein the ablation includes but is not limited to radiofrequency energy, freezing energy, or other forms energy in the electromagnetic spectrum.

9. A non-transitory computer readable medium comprising instructions that, when executed by a computing device, cause the computing device to:

determine values for each of a plurality of points associated with cardiac signal data for a given spatial region of tissue, the values corresponding to electrical information for each respective point of the plurality of points within a plurality of time intervals;

process the values for each of the plurality of points within a first time interval of the plurality of time intervals to generate a first map;

process the values for each of the plurality of points within one or more successive time intervals of the plurality of time intervals to generate one or more successive maps; 35

compare the first map and the one or more successive maps relative to reference signals in a database to identify activation onsets; and

generate an output map of successive cardiac signals for the given spatial region of tissue based on the compared maps, the output map comprising a clinical representation of activation patterns within the given spatial region of tissue.

10. The computer readable medium of claim 9, wherein the output map identifies a source of a cardiac rhythm disorder.

11. The computer readable medium of claim 10, wherein the source is rotational.

12. The computer readable medium of claim 11, wherein the source is a rotor.

\* \* \* \* \*

专利名称(译)	用于重建心脏激动信息的系统和方法		
公开(公告)号	<a href="#">US10149622</a>	公开(公告)日	2018-12-11
申请号	US15/244792	申请日	2016-08-23
[标]申请(专利权)人(译)	加利福尼亚大学董事会 托佩拉公司		
申请(专利权)人(译)	加利福尼亚大学董事会 TOPERA INC.		
当前申请(专利权)人(译)	加利福尼亚大学董事会 TOPERA INC. 美洲的美国为代表的退伍军人事务部		
[标]发明人	NARAYAN SANJIV BRIGGS CAREY ROBERT		
发明人	NARAYAN, SANJIV BRIGGS, CAREY ROBERT		
IPC分类号	A61B5/024 A61B5/00 A61B5/0205 A61B5/0452 A61B5/042 A61B5/04 A61B5/046 A61B5/0464 A61B5/0255 A61B18/02 A61B18/12 A61B18/18 A61B18/00		
CPC分类号	A61B5/02405 A61B5/0205 A61B5/0255 A61B5/046 A61B5/04011 A61B5/04012 A61B5/0422 A61B5/0452 A61B5/0464 A61B5/4836 A61B5/6852 A61B5/7203 A61B5/7217 A61B5/7239 A61B5/7246 A61B5/7278 A61B5/7282 A61B5/742 A61B5/743 A61B18/02 A61B18/12 A61B18/18 A61B5/0002 A61B2562/046 A61B2018/00577 A61B5/0036		
优先权	14/473905 2015-06-16 US 14/074619 2015-06-16 US 13/217123 2012-04-24 US 61/481607 2011-05-02 US		
其他公开文献	US20160360983A1		
外部链接	<a href="#">Espacenet</a>		

摘要(译)

在重建心脏激动信息的系统和方法中，访问从患者获得的心脏信号对。这些对具有在对中共有的第一心脏信号和在这对中共有的第二心脏信号。处理第一心脏信号和第二心脏信号以识别第一心脏信号中的变化点，在该第一心脏信号中，第一心脏信号的导数相对于第二心脏信号的导数发散。基于变化点的对应关系在第一心脏信号中的点处分配激活开始时间，以定义指示搏动的的心脏激动。

