



US010028783B2

(12) **United States Patent**
Gelbart et al.

(10) **Patent No.: US 10,028,783 B2**
(45) **Date of Patent: Jul. 24, 2018**

(54) **APPARATUS AND METHOD FOR
INTRA-CARDIAC MAPPING AND
ABLATION**

(71) Applicant: **Kardium Inc.**, Richmond (CA)
(72) Inventors: **Daniel Gelbart**, Vancouver (CA);
Samuel Victor Lichtenstein, Vancouver
(CA)

(73) Assignee: **KARDIUM INC.**, Burnaby (CA)
(*) Notice: Subject to any disclaimer, the term of this
patent is extended or adjusted under 35
U.S.C. 154(b) by 40 days.

(21) Appl. No.: **13/785,910**

(22) Filed: **Mar. 5, 2013**

(65) **Prior Publication Data**

US 2013/0184705 A1 Jul. 18, 2013

Related U.S. Application Data

(63) Continuation-in-part of application No. 11/475,950,
filed on Jun. 28, 2006, now Pat. No. 8,920,411.

(51) **Int. Cl.**
A61B 18/12 (2006.01)
A61B 18/14 (2006.01)
(Continued)

(52) **U.S. Cl.**
CPC **A61B 18/1492** (2013.01); **A61B 5/028**
(2013.01); **A61B 5/6858** (2013.01);
(Continued)

(58) **Field of Classification Search**
CPC .. A61B 2018/0016; A61B 2018/00267; A61B
2018/00357; A61B 2018/00375;
(Continued)

(56) **References Cited**

U.S. PATENT DOCUMENTS

4,114,202 A 9/1978 Roy et al.
4,164,046 A 8/1979 Cooley
(Continued)

FOREIGN PATENT DOCUMENTS

CN 101797181 A 8/2010
EP 0723467 B1 4/2002
(Continued)

OTHER PUBLICATIONS

Becker, et al., "Ablation of Atrial Fibrillation: Energy Sources and
Navigation Tools: A Review", Journal of Electrocardiology, vol. 37,
Supplement 2004, pp. 55-62 (Cited in Parent U.S. Appl. No.
11/475,950).

(Continued)

Primary Examiner — Ronald Hupczey, Jr.
(74) *Attorney, Agent, or Firm* — Rossi, Kimms &
McDowell LLP

(57) **ABSTRACT**

An intra-cardiac mapping system is based on locating the
ports through which blood flows in or out the heart cham-
bers. For many procedures, such as ablation to cure atrial
fibrillation, locating the pulmonary veins and the mitral
valve accurately allows to perform a Maze procedure. The
location of the ports and valves is based on using the
convective cooling effect of the blood flow. The mapping
can be performed by a catheter-deployed expandable net or
a scanning catheter. The same net or catheter can also
perform the ablation procedure.

54 Claims, 8 Drawing Sheets

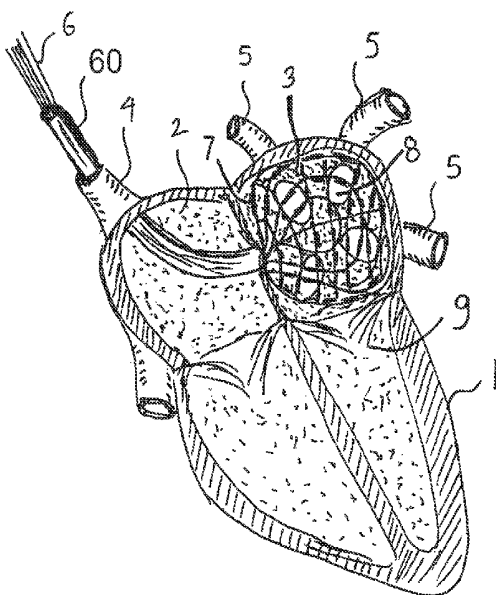

(51)	Int. Cl.							
	<i>A61B 5/028</i>	(2006.01)		5,297,549 A	3/1994	Beatty et al.		
	<i>A61B 18/10</i>	(2006.01)		5,309,910 A	5/1994	Edwards et al.		
	<i>A61B 18/08</i>	(2006.01)		5,312,435 A	5/1994	Nash et al.		
	<i>A61B 5/00</i>	(2006.01)		5,317,952 A	6/1994	Imnega		
	<i>A61B 18/18</i>	(2006.01)		5,324,284 A	6/1994	Imran		
	<i>A61B 18/20</i>	(2006.01)		5,327,889 A	7/1994	Imran		
	<i>A61B 18/00</i>	(2006.01)		5,341,807 A	8/1994	Nardella		
	<i>A61B 18/02</i>	(2006.01)		5,345,936 A	9/1994	Pomeranz et al.		
(52)	U.S. Cl.			5,351,679 A	10/1994	Mayzels et al.		
	CPC	<i>A61B 18/082</i> (2013.01); <i>A61B 18/10</i>		5,366,443 A	11/1994	Eggers et al.		
		(2013.01); <i>A61B 5/6853</i> (2013.01); <i>A61B</i>		5,370,679 A	12/1994	Atlee, III		
		<i>18/18</i> (2013.01); <i>A61B 18/20</i> (2013.01); <i>A61B</i>		5,379,773 A	1/1995	Hornsby		
		<i>2018/0016</i> (2013.01); <i>A61B 2018/0022</i>		5,397,321 A	3/1995	Houser et al.		
		(2013.01); <i>A61B 2018/00267</i> (2013.01); <i>A61B</i>		5,419,767 A	5/1995	Eggers et al.		
		<i>2018/00357</i> (2013.01); <i>A61B 2018/00577</i>		5,450,860 A	9/1995	O'Connor		
		(2013.01); <i>A61B 2018/00642</i> (2013.01); <i>A61B</i>		5,456,254 A	10/1995	Pietroski et al.		
		<i>2018/00714</i> (2013.01); <i>A61B 2018/00791</i>		5,465,717 A	11/1995	Imran et al.		
		(2013.01); <i>A61B 2018/0212</i> (2013.01); <i>A61B</i>		5,478,353 A	12/1995	Yoon		
		<i>2018/0237</i> (2013.01); <i>A61B 2018/124</i>		5,485,849 A	1/1996	Panescu et al.		
		(2013.01); <i>A61B 2018/1407</i> (2013.01); <i>A61B</i>		5,496,267 A	3/1996	Drasler et al.		
		<i>2562/0271</i> (2013.01); <i>A61B 2562/046</i>		5,499,981 A	3/1996	Kordis		
		(2013.01)		5,531,760 A	7/1996	Alwafaie		
(58)	Field of Classification Search			5,545,193 A	8/1996	Fleischman et al.		
	CPC	<i>A61B 2018/00654</i> ; <i>A61B 5/743</i> ; <i>A61B</i>		5,549,661 A	8/1996	Kordis et al.		
		<i>5/7435</i> ; <i>A61B 5/748</i> ; <i>A61B 2017/00199</i>		5,555,883 A	9/1996	Avitall		
	See application file for complete search history.			5,557,967 A	9/1996	Renger		
				5,575,810 A	11/1996	Swanson et al.		
				5,593,424 A	1/1997	Northrup, III		
				5,598,848 A	2/1997	Swanson et al.		
				5,599,345 A	2/1997	Edwards et al.		
				5,620,481 A	4/1997	Desai et al.		
				5,637,090 A *	6/1997	McGee	<i>A61B 5/0422</i>	
							600/374	
				5,662,587 A	9/1997	Grundfest et al.		
(56)	References Cited			5,681,308 A	10/1997	Edward et al.		
	U.S. PATENT DOCUMENTS			5,681,336 A	10/1997	Clement et al.		
				5,687,723 A	11/1997	Avitall		
				5,687,737 A	11/1997	Branham et al.		
				5,697,285 A	12/1997	Nappi et al.		
				5,713,896 A	2/1998	Nardella		
				5,713,942 A	2/1998	Stern et al.		
				5,716,397 A	2/1998	Myers		
				5,720,726 A	2/1998	Marcadis et al.		
				5,728,114 A	3/1998	Evans et al.		
				5,730,127 A	3/1998	Avitall		
				5,738,096 A	4/1998	Ben-Haim		
				5,762,066 A	6/1998	Law et al.		
				5,769,846 A	6/1998	Edwards et al.		
				5,782,239 A	7/1998	Webster, Jr.		
				5,782,879 A	7/1998	Rosborough et al.		
				5,800,495 A	9/1998	Machek et al.		
				5,823,189 A	10/1998	Kordis		
				5,824,066 A	10/1998	Gross		
				5,836,947 A	11/1998	Fleischman et al.		
				5,836,990 A	11/1998	Li		
				5,853,422 A	12/1998	Huebsch et al.		
				5,868,755 A	2/1999	Kanner et al.		
				5,876,343 A	3/1999	Teo		
				5,881,727 A	3/1999	Edwards		
				5,885,278 A	3/1999	Fleischman		
				5,891,136 A	4/1999	McGee et al.		
				5,893,847 A	4/1999	Kordis		
				5,904,711 A	5/1999	Flom et al.		
				5,916,163 A	6/1999	Panescu et al.		
				5,919,207 A	7/1999	Taheri		
				5,921,924 A	7/1999	Avitall		
				5,935,075 A	8/1999	Casscells et al.		
				5,935,079 A	8/1999	Swanson et al.		
				5,941,251 A	8/1999	Panescu et al.		
				5,944,715 A	8/1999	Goble et al.		
				5,961,440 A	10/1999	Schweich, Jr. et al.		
				5,968,040 A	10/1999	Swanson et al.		
				5,984,950 A	11/1999	Cragg et al.		
				6,001,069 A	12/1999	Tachibana et al.		
				6,001,093 A	12/1999	Swanson et al.		
				6,014,581 A	1/2000	Whayne et al.		
				6,023,638 A *	2/2000	Swanson	<i>A61B 5/0422</i>	
							600/510	
				6,030,382 A	2/2000	Fleischman et al.		

(56)

References Cited

U.S. PATENT DOCUMENTS

6,036,689 A	3/2000	Tu et al.	6,926,669 B1	8/2005	Stewart et al.	
6,063,082 A	5/2000	DeVore et al.	6,942,657 B2	9/2005	Sinofsky et al.	
6,071,282 A	6/2000	Fleischman	6,949,122 B2	9/2005	Adams et al.	
6,104,944 A	8/2000	Martinelli	6,960,206 B2	11/2005	Keane	
6,106,522 A	8/2000	Fleischman et al.	6,960,229 B2	11/2005	Mathis et al.	
6,119,030 A	9/2000	Morency	6,986,775 B2	1/2006	Morales et al.	
6,123,702 A	9/2000	Swanson et al.	6,989,010 B2	1/2006	Francischelli et al.	
6,138,043 A	10/2000	Avitall	6,989,028 B2	1/2006	Lashinski et al.	
6,142,993 A	11/2000	Wayne et al.	6,994,093 B2	2/2006	Murphy et al.	
6,156,046 A	12/2000	Passafaro et al.	6,997,951 B2	2/2006	Solem et al.	
6,210,432 B1	4/2001	Solem et al.	7,001,383 B2	2/2006	Keidar	
6,216,043 B1	4/2001	Swanson et al.	7,025,776 B1	4/2006	Houser et al.	
6,217,573 B1	4/2001	Webster	7,048,734 B1	5/2006	Fleischman et al.	
6,241,747 B1	6/2001	Ruff	7,050,848 B2	5/2006	Hoey et al.	
6,248,124 B1	6/2001	Pedros et al.	7,052,487 B2	5/2006	Cohn et al.	
6,258,258 B1	7/2001	Sartori	7,068,867 B2	6/2006	Adoram et al.	
6,266,550 B1	7/2001	Selmon et al.	7,141,019 B2	11/2006	Pearlman	
6,304,769 B1	10/2001	Arenson et al.	7,144,363 B2	12/2006	Pai et al.	
6,306,135 B1	10/2001	Ellmam et al.	7,166,127 B2	1/2007	Spence et al.	
6,308,091 B1	10/2001	Avitall	7,174,201 B2 *	2/2007	Govari	A61B 5/06 382/124
6,319,249 B1	11/2001	Töllner	7,177,677 B2	2/2007	Kaula et al.	
6,322,559 B1	11/2001	Daulton et al.	7,186,210 B2	3/2007	Feld et al.	
6,330,478 B1	12/2001	Lee et al.	7,187,964 B2	3/2007	Khoury	
6,346,105 B1	2/2002	Tu et al.	7,189,202 B2	3/2007	Lau et al.	
6,350,263 B1	2/2002	Wetzig et al.	7,189,202 B2	3/2007	Lau et al.	
6,358,258 B1	3/2002	Arcia et al.	7,198,635 B2	4/2007	Danek et al.	
6,383,151 B1	5/2002	Diederich et al.	7,255,695 B2	8/2007	Falwell et al.	
6,389,311 B1	5/2002	Wayne et al.	7,276,044 B2	10/2007	Ferry et al.	
6,391,024 B1	5/2002	Sun et al.	7,279,007 B2	10/2007	Nikolic et al.	
6,391,048 B1	5/2002	Ginn et al.	7,300,435 B2	11/2007	Wham et al.	
6,391,054 B2	5/2002	Carpentier et al.	7,303,526 B2	12/2007	Sharkey et al.	
6,402,781 B1	6/2002	Langberg et al.	7,335,196 B2	2/2008	Swanson et al.	
6,436,052 B1	8/2002	Nikolic et al.	7,481,808 B2	1/2009	Koyfman et al.	
6,475,223 B1	11/2002	Werp et al.	7,507,252 B2	3/2009	Lashinski et al.	
6,485,409 B1	11/2002	Voloshin et al.	7,530,980 B2	5/2009	Hooven	
6,485,482 B1	11/2002	Belef	7,660,452 B2	2/2010	Zwirn et al.	
6,485,489 B2	11/2002	Teirstein et al.	7,736,388 B2	6/2010	Goldfarb et al.	
6,506,210 B1	1/2003	Kanner	7,738,967 B2	6/2010	Salo	
6,514,249 B1	2/2003	Maguire et al.	8,103,338 B2	1/2012	Harley et al.	
6,529,756 B1	3/2003	Phan et al.	D654,588 S	2/2012	Taube et al.	
6,537,198 B1	3/2003	Vidlund et al.	8,118,853 B2	2/2012	Grewe	
6,537,314 B2	3/2003	Langberg et al.	8,150,499 B2	4/2012	Gelbart et al.	
6,540,670 B1	4/2003	Hirata et al.	D660,967 S	5/2012	Braido et al.	
6,551,310 B1	4/2003	Ganz et al.	8,224,432 B2	7/2012	MacAdam et al.	
6,551,312 B2	4/2003	Zhang et al.	8,657,814 B2 *	2/2014	Werneth	A61B 5/0422 606/32
6,569,160 B1	5/2003	Goldin et al.	D717,954 S	11/2014	Hjelle et al.	
6,569,198 B1	5/2003	Wilson et al.	9,198,713 B2	12/2015	Wallace et al.	
6,575,971 B2	6/2003	Hauck et al.	2001/0003158 A1	6/2001	Kensey et al.	
6,589,208 B2	7/2003	Ewers et al.	2001/0005787 A1	6/2001	Oz et al.	
6,616,684 B1	9/2003	Vidlund et al.	2001/0018611 A1	8/2001	Solem et al.	
6,626,930 B1	9/2003	Allen et al.	2001/0020126 A1	9/2001	Swanson et al.	
6,632,238 B2	10/2003	Ginn et al.	2001/0021867 A1	9/2001	Kordis et al.	
6,635,056 B2	10/2003	Kadhiresan et al.	2002/0002329 A1	1/2002	Avitall	
6,640,119 B1	10/2003	Budd et al.	2002/0016628 A1	2/2002	Langberg et al.	
6,662,034 B2	12/2003	Segner et al.	2002/0087156 A1 *	7/2002	Maguire et al.	606/41
D484,979 S	1/2004	Fontaine	2002/0087173 A1	7/2002	Alferness et al.	
6,704,590 B2	3/2004	Haldeman	2002/0099415 A1	7/2002	Panescu et al.	
6,723,038 B1	4/2004	Schroeder et al.	2002/0107478 A1	8/2002	Wendlandt	
6,726,716 B2	4/2004	Marquez	2002/0107511 A1	8/2002	Collins et al.	
6,760,616 B2	7/2004	Hoey et al.	2002/0107530 A1	8/2002	Saucer et al.	
6,780,197 B2	8/2004	Roe et al.	2002/0115941 A1 *	8/2002	Wayne	G06K 1/121 600/523
6,788,969 B2	9/2004	Dupree et al.	2002/0115944 A1	8/2002	Mendes et al.	
6,797,001 B2	9/2004	Mathis et al.	2002/0169504 A1	11/2002	Alferness et al.	
6,800,090 B2	10/2004	Alferness et al.	2002/0177782 A1	11/2002	Penner	
6,824,562 B2	11/2004	Mathis et al.	2002/0183836 A1	12/2002	Liddicoat et al.	
6,837,886 B2	1/2005	Collins et al.	2002/0183841 A1	12/2002	Cohn et al.	
6,852,076 B2	2/2005	Nikolic et al.	2002/0188170 A1	12/2002	Santamore et al.	
6,855,143 B2	2/2005	Davison et al.	2003/0028118 A1 *	2/2003	Dupree et al.	600/509
6,890,353 B2	5/2005	Cohn et al.	2003/0028183 A1	2/2003	Sanchez et al.	
6,892,091 B1	5/2005	Ben-Haim et al.	2003/0050685 A1	3/2003	Nikolic et al.	
6,899,674 B2	5/2005	Viebach et al.	2003/0055420 A1	3/2003	Kadhiresan et al.	
6,907,297 B2	6/2005	Wellman et al.	2003/0069570 A1	4/2003	Witzel et al.	
6,908,478 B2	6/2005	Alferness et al.	2003/0069636 A1	4/2003	Solem et al.	
6,913,576 B2	7/2005	Bowman	2003/0078465 A1	4/2003	Pai et al.	
6,918,903 B2	7/2005	Bass	2003/0078671 A1	4/2003	Lesniak et al.	
			2003/0105384 A1	6/2003	Sharkey et al.	
			2003/0105520 A1	6/2003	Alferness et al.	

(56)

References Cited

U.S. PATENT DOCUMENTS

2003/0109770	A1	6/2003	Sharkey et al.
2003/0176810	A1	9/2003	Maahs et al.
2003/0181819	A1	9/2003	Desai
2003/0229395	A1	12/2003	Cox
2004/0002626	A1	1/2004	Feld et al.
2004/0054279	A1	3/2004	Hanley
2004/0133220	A1	7/2004	Lashinski et al.
2004/0133273	A1	7/2004	Cox
2004/0138744	A1	7/2004	Lashinski et al.
2004/0153146	A1	8/2004	Lashinski et al.
2004/0158321	A1	8/2004	Reuter et al.
2004/0176797	A1	9/2004	Opolski
2004/0181139	A1	9/2004	Falwell et al.
2004/0186566	A1	9/2004	Hindrichs et al.
2004/0215232	A1	10/2004	Belhe et al.
2004/0243170	A1	12/2004	Suresh et al.
2004/0249408	A1	12/2004	Murphy et al.
2004/0249453	A1	12/2004	Cartledge et al.
2004/0267358	A1	12/2004	Reitan
2005/0004668	A1	1/2005	Aklog et al.
2005/0015109	A1	1/2005	Lichtenstein
2005/0054938	A1	3/2005	Wehman et al.
2005/0055089	A1	3/2005	Macoviak et al.
2005/0060030	A1	3/2005	Lashinski et al.
2005/0064665	A1	3/2005	Han
2005/0065420	A1	3/2005	Collins et al.
2005/0065504	A1	3/2005	Melsky et al.
2005/0080402	A1	4/2005	Santamore et al.
2005/0096047	A1	5/2005	Haberman et al.
2005/0096647	A1	5/2005	Steinke et al.
2005/0107723	A1	5/2005	Wehman et al.
2005/0107871	A1	5/2005	Realyvasques et al.
2005/0125030	A1	6/2005	Forsberg et al.
2005/0148892	A1	7/2005	Desai
2005/0149014	A1	7/2005	Hauck et al.
2005/0149159	A1	7/2005	Andreas et al.
2005/0154252	A1	7/2005	Sharkey et al.
2005/0182365	A1	8/2005	Hennemann
2005/0187620	A1	8/2005	Pai et al.
2005/0197593	A1	9/2005	Burbank et al.
2005/0197692	A1	9/2005	Pai et al.
2005/0197693	A1	9/2005	Pai et al.
2005/0197694	A1	9/2005	Pai et al.
2005/0203558	A1	9/2005	Maschke
2005/0209636	A1	9/2005	Widomski et al.
2005/0216054	A1	9/2005	Widomski et al.
2005/0240249	A1	10/2005	Tu et al.
2005/0251116	A1	11/2005	Steinke et al.
2005/0251132	A1	11/2005	Oral et al.
2005/0256521	A1	11/2005	Kozel
2005/0261580	A1	11/2005	Willis et al.
2005/0267458	A1	12/2005	Paul et al.
2005/0267574	A1	12/2005	Cohn et al.
2006/0009755	A1	1/2006	Sra
2006/0009756	A1	1/2006	Francischelli et al.
2006/0014998	A1	1/2006	Sharkey et al.
2006/0015002	A1	1/2006	Moaddeb et al.
2006/0015003	A1	1/2006	Moaddes et al.
2006/0015038	A1	1/2006	Weymarn-Scharli
2006/0015096	A1	1/2006	Hauck et al.
2006/0025800	A1	2/2006	Suresh
2006/0030881	A1	2/2006	Sharkey et al.
2006/0085049	A1	4/2006	Cory et al.
2006/0089637	A1	4/2006	Werneth et al.
2006/0100618	A1	5/2006	Chan et al.
2006/0106298	A1	5/2006	Ahmed et al.
2006/0135968	A1	6/2006	Schaller
2006/0135970	A1	6/2006	Schaller
2006/0184242	A1	8/2006	Lichtenstein
2006/0199995	A1	9/2006	Vijay
2006/0229491	A1	10/2006	Sharkey et al.
2006/0235286	A1	10/2006	Stone et al.
2006/0235314	A1	10/2006	Migliuolo et al.
2006/0264980	A1	11/2006	Khairkhahan et al.
2006/0281965	A1	12/2006	Khairkhahan et al.
2006/0293698	A1	12/2006	Douk
2006/0293725	A1	12/2006	Rubinsky et al.
2007/0016068	A1	1/2007	Grunwald et al.
2007/0027533	A1	2/2007	Douk
2007/0038208	A1	2/2007	Kefer
2007/0083193	A1	4/2007	Werneth et al.
2007/0083195	A1	4/2007	Werneth et al.
2007/0088362	A1	4/2007	Bonutti et al.
2007/0115390	A1	5/2007	Makara et al.
2007/0118215	A1	5/2007	Moaddeb
2007/0129717	A1	6/2007	Brown, III et al.
2007/0161846	A1	7/2007	Nikolic et al.
2007/0198058	A1	8/2007	Gelbart et al.
2007/0213578	A1	9/2007	Khairkhahan et al.
2007/0213815	A1	9/2007	Khairkhahan et al.
2007/0232858	A1	10/2007	MacNamara et al.
2007/0249999	A1	10/2007	Sklar et al.
2007/0270688	A1	11/2007	Gelbart et al.
2007/0299343	A1	12/2007	Waters
2008/0004534	A1	1/2008	Gelbart et al.
2008/0004643	A1	1/2008	To et al.
2008/0004697	A1	1/2008	Lichtenstein et al.
2008/0045778	A1	2/2008	Lichtenstein et al.
2008/0071298	A1	3/2008	Khairkhahan et al.
2008/0262337	A1	10/2008	Falwell et al.
2008/0281322	A1	11/2008	Sherman et al.
2008/0312713	A1	12/2008	Wilfley et al.
2009/0018617	A1	1/2009	Skelton et al.
2009/0024138	A1	1/2009	Saleh
2009/0069704	A1	3/2009	MacAdam et al.
2009/0131930	A1	5/2009	Gelbart et al.
2009/0157058	A1	6/2009	Ferren et al.
2009/0171274	A1	7/2009	Harlev et al.
2009/0192441	A1	7/2009	Gelbart et al.
2009/0270737	A1	10/2009	Thornton
2009/0287271	A1	11/2009	Blum et al.
2009/0287304	A1	11/2009	Dahlgren et al.
2010/0121147	A1	5/2010	Oskin et al.
2010/0211052	A1	8/2010	Brown et al.
2010/0249771	A1	9/2010	Pearson et al.
2010/0268059	A1	10/2010	Ryu et al.
2011/0125172	A1	5/2011	Gelbart et al.
2011/0172658	A1	7/2011	Gelbart et al.
2011/0213231	A1	9/2011	Hall et al.
2011/0282491	A1	11/2011	Prisco et al.
2012/0158016	A1	6/2012	Gelbart et al.
2012/0165829	A1	6/2012	Chen et al.
2012/0271135	A1	10/2012	Burke et al.
2013/0165916	A1	6/2013	Mathur et al.
2013/0172883	A1	7/2013	Lopes et al.
2013/0178850	A1	7/2013	Lopes et al.
2013/0178851	A1	7/2013	Lopes et al.
2013/0184706	A1	7/2013	Gelbart et al.
2013/0190587	A1	7/2013	Lopes et al.
2013/0190741	A1	7/2013	Möll et al.
2013/0197513	A1	8/2013	Lopes et al.
2013/0241929	A1*	9/2013	Massarwa et al. 345/421
2013/0304065	A1	11/2013	Lopes et al.
2013/0310828	A1*	11/2013	Reinders et al. 606/34
2014/0114307	A1	4/2014	Moisa et al.
2014/0350552	A1	11/2014	Highsmith
2015/0045660	A1	2/2015	Gelbart et al.
2015/0126993	A1	5/2015	Gelbart et al.
2015/0157400	A1	6/2015	Gelbart et al.
2015/0245798	A1	9/2015	Gelbart et al.
2015/0250539	A1	9/2015	Gelbart et al.
2015/0351837	A1	12/2015	Gelbart et al.
2016/0008062	A1	1/2016	Gelbart et al.
2016/0367315	A1	12/2016	Moisa et al.
2017/0020604	A1	1/2017	Lopes et al.
2017/0035486	A1	2/2017	Lopes et al.
FOREIGN PATENT DOCUMENTS			
WO	95/10320	A1	4/1995
WO	95/20349	A1	8/1995
WO	97/17892	A1	5/1997
WO	0108575	A2	2/2001
WO	02/087437	A1	11/2002

(56) **References Cited**

FOREIGN PATENT DOCUMENTS

WO	03/015611	A2	2/2003
WO	03/077800	A1	9/2003
WO	2004/012629	A1	2/2004
WO	2004/047679	A1	6/2004
WO	2004/084746	A2	10/2004
WO	2004/100803	A1	11/2004
WO	2005/070330	A1	8/2005
WO	2005/102181	A1	11/2005
WO	2006/017809	A2	2/2006
WO	2006/105121	A2	10/2006
WO	2006/135747	A2	12/2006
WO	2006/135749	A2	12/2006
WO	2007/021647	A2	2/2007
WO	2007/115390	A1	10/2007
WO	2008/002606	A2	1/2008
WO	2009/011721	A1	1/2009
WO	2009/065042	A2	5/2009
WO	2012/050877	A1	4/2012
WO	2012/100184	A2	7/2012
WO	2012/100185	A2	7/2012
WO	2013/173917	A1	11/2013

OTHER PUBLICATIONS

Buchbinder, Maurice, "Dynamic Mitral Valve Annuloplasty: A Reshapable Ring for Residual and Recurring MR", Foundation for Cardiovascular Medicine, May 24, 2007 (Cited in Parent U.S. Appl. No. 11/475,950).

Calkins, Hugh, "Electrophysiology: Radiofrequency Catheter Ablation of Supraventricular Arrhythmias", Heart, 2001; 85; pp. 594-600 (Cited in Parent U.S. Appl. No. 11/475,950).

De Ponti, et al., "Non-Fluoroscopic Mapping Systems for Electrophysiology: the Tool or Toy Dilemma After 10 Years", European Heart Journal, 2006; 27, pp. 1134-1136 (Cited in Parent U.S. Appl. No. 11/475,950).

Gabriel, et al., "The Dielectric Properties of Biological Tissues: I. Literature Survey", Phys. Med. Biol.; 41, 1996, pp. 2231-2249 (Cited in Parent U.S. Appl. No. 11/475,950).

Konings, et al., "Development of an Intravascular Impedance Catheter for Detection of Fatty Lesions in Arteries", IEEE Transactions on Medical Imaging, vol. 16, No. 4, Aug. 1997, pp. 439-446 (Cited in U.S. Appl. No. 11/475,950).

Mack, Michael J., "New Techniques for Percutaneous Repair of the Mitral Valve", Heart Fail Rev, 2006; 11, pp. 259-268 (Cited in Parent U.S. Appl. No. 11/475,950).

Otasevic, et al., "First-in-Man Implantation of Left Ventricular Partitioning Device in a Patient With Chronic Heart Failure: Twelve-Month Follow-Up", Journal of Cardiac Failure, vol. 13, No. 7, 2007, pp. 517-520 (Cited in Parent U.S. Appl. No. 11/475,950).

Sharkey, et al., "Left Ventricular Apex Occluder. Description of a Ventricular Partitioning Device", EuroIntervention, 2006, pp. 125-127 (Cited in Parent U.S. Appl. No. 11/475,950).

Stiles, et al., "Simulated Characterization of Atherosclerotic Lesions in the Coronary Arteries by Measurement of Bioimpedance", IEEE Transactions on Biomedical Engineering, vol. 50, No. 7, Jul. 2003, pp. 916-921 (Cited in Parent U.S. Appl. No. 11/475,950).

Tanaka, et al., "Artificial SMA Valve for Treatment of Urinary Incontinence: Upgrading of Valve and Introduction of Transcutaneous Transformer", Bio-Medical Materials and Engineering; vol. 9, 1999, pp. 97-112 (Cited in Parent U.S. Appl. No. 11/475,950).

Timek, et al., "Septal-Lateral Annular Cinching Abolishes Acute Ischemic Mitral Regurgitation", Journal of Thoracic and Cardiovascular Surgery, vol. 123, No. 5, May 2002, pp. 881-888 (Cited in Parent U.S. Appl. No. 11/475,950).

Timek, et al., "Septal-Lateral Annular Cinching (SLAC) Reduces Mitral Annular Size Without Perturbing Normal Annular Dynamics", Journal of Heart Valve Disease, vol. 11, No. 1, Jan. 2002 (Cited in Parent U.S. Appl. No. 11/475,950).

Valvano, et al., "Thermal Conductivity and Diffusivity of Biomaterials Measured with Self-Heated Thermistors", Interna-

tional Journal of Thermophysics, vol. 6, No. 3, 1985, pp. 301-311 (Cited in Parent U.S. Appl. No. 11/475,950).

Prosecution Documents for U.S. Appl. No. 11/436,584, now abandoned (Cited in Parent U.S. Appl. No. 11/475,950).

Prosecution Documents for U.S. Appl. No. 11/941,819, now published as US 2009-0131930 A1 (Cited in Parent U.S. Appl. No. 11/475,950).

Prosecution Documents for U.S. Appl. No. 12/010,458, now published as US 2009-0192441 A1 (Cited in Parent U.S. Appl. No. 11/475,950).

Prosecution Documents for U.S. Appl. No. 12/950,871, now patented as U.S. Pat. No. 8,150,499 (Cited in Parent U.S. Appl. No. 11/475,950).

Specification and Drawings of U.S. Appl. No. 10/690,131 (Cited in Parent U.S. Appl. No. 11/475,950).

International Search Report, dated Dec. 5, 2007 for PCT/US2007/014902, 5 pages.

International Search Report, dated Dec. 2, 2009 for PCT/US2008/083644, 5 pages.

International Preliminary Report on Patentability, dated Jan. 6, 2009 for PCT/US2007/014902, 8 pages.

Written Opinion, dated Dec. 5, 2007, for PCT/US2007/014902, 7 pages.

Written Opinion, dated Dec. 2, 2009, for PCT/US2008/083644, 9 pages.

International Search Report and Written Opinion dated Aug. 2, 2013 issued in PCT/CA2013/050350.

International Search Report and Written Opinion dated Sep. 17, 2013 issued in PCT/US2013/039982.

International Search Report and Written Opinion dated Sep. 27, 2013 issued in PCT/US2013/039977.

Extended European Search Report dated Aug. 20, 2013 issued in EP Patent Application No. 13172848.7.

Non-final Office Action issued in co-pending U.S. Appl. No. 13/782,867, dated Apr. 15, 2015.

Non-final Office Action issued in co-pending U.S. Appl. No. 13/782,903, dated Apr. 28, 2015.

Lopes et al., "Enhanced Medical Device for Use in Bodily Cavities, for Example an Atrium", Office Action dated May 22, 2015 for U.S. Appl. No. 13/782,889, 86 pages.

Ensite System Instructions for use, 54-06154-001 Rev02, Chapter 7 Waveforms and Segments, pp. 85-90.

"Phased RF Catheter Ablation System", 2014 Medtronic Inc., 2 pgs, <http://www.medtronic.eu/your-health/atrial-fibrillation/about-the-therapy/our-phased-rf-ablation-system/> [Jun. 24, 2014 2:38:05 PM].

"ThermoCool® Irrigated Tip Catheter", Brochure, Biosense Webster, 4 pgs, Biosense Webster, Inc. 3333 Diamond Canyon Road Diamond Bar, CA 91765, USA, © Biosense Webster, Inc. 2009 All rights reserved. 1109003.0.

Biotronik's "AlCath Flutter Gold Cath for Atrial Flutter Available in EU", medGadget, 3 pgs, <http://www.medgadget.com/2013/09/biotroniks-alcath-flutter-gold-cath-for-atrial-flutter-unveiled-in-europe.html> [Jun. 24, 2014 2:37:09 PM].

Extended European Search Report and EP search opinion for EP 12736677.1, dated Mar. 28, 2014, corresponding to PCT/US2012/022061.

Extended European Search Report and EP search opinion for EP 12736677.7, dated Mar. 28, 2014, corresponding to PCT/US2012/022062.

Gelbart et al., "Automatic Atherectomy System", Amendment filed Oct. 25, 2010 for U.S. Appl. No. 11/436,584, 9 pgs.

Gelbart et al., "Automatic Atherectomy System", Amendment filed Mar. 30, 2010 for U.S. Appl. No. 11/436,584, 20 pgs.

Gelbart et al., "Automatic Atherectomy System", Amendment filed Aug. 4, 2009 for U.S. Appl. No. 11/436,584, 35 pgs.

Gelbart et al., "Automatic Atherectomy System", Amendment filed Sep. 15, 2011 for U.S. Appl. No. 12/950,871, 21 pgs.

Gelbart et al., "Automatic Atherectomy System", Office Action dated Jun. 15, 2011 for U.S. Appl. No. 12/950,871, 16 pgs.

Gelbart et al., "Automatic Atherectomy System", Office Action dated Dec. 1, 2009 for U.S. Appl. No. 11/436,584, 8 pgs.

Gelbart et al., "Automatic Atherectomy System", Office Action dated Dec. 14, 2010 for U.S. Appl. No. 11/436,584, 12 pgs.

(56)

References Cited

OTHER PUBLICATIONS

- Gelbart et al., "Automatic Atherectomy System", Office Action dated Mar. 4, 2009 for U.S. Appl. No. 11/436,584, 6 pgs.
- Bard, "HD Mesh Ablator Catheter", Brochure, 2008, 4 pgs, Bard Electrophysiology Division, C.R. Bard Inc., 55 Technology Drive Lowell, MA 01851 USA.
- "Constellation Mapping Catheters", Brochure, Boston Scientific Corp., 2 pgs, © 2007 Boston Scientific Corporation.
- Written opinion dated Jul. 30, 2012 for PCT/US2012/022062, 5 pgs.
- Written opinion dated Aug. 22, 2012 for PCT/US2012/022061, 6 pgs.
- International Search Report dated Aug. 22, 2012 for PCT/US2012/022061, 5 pgs.
- International Search Report dated Jul. 30, 2012 for PCT/US2012/022062, 5 pgs.
- Gelbart et al., "Medical Device for Use in Bodily Lumens, for Example an Atrium", Office Action dated Jul. 25, 2011 for U.S. Appl. No. 11/941,819, now published as US 2009-0131930 A1.
- Gelbart et al., "Liposuction System", Amendment filed Jun. 10, 2011 for U.S. Appl. No. 12/010,458, 10 pgs.
- Gelbart et al., "Liposuction System", Amendment filed Dec. 7, 2011 for U.S. Appl. No. 12/010,458, 15 pgs.
- Gelbart et al., "Liposuction System", Office Action dated Mar. 16, 2011 for U.S. Appl. No. 12/010,458, 12 pgs.
- Gelbart et al., "Liposuction System", Office Action dated Sep. 14, 2011 for U.S. Appl. No. 12/010,458, 9 pgs.
- "Waveforms and Segments", Ensite System Instructions for use, 54-06154-001 Rev02, Chapter 7, pp. 85-90 © 2007 St. Jude Medical.
- Gelbart et al., "Intra-Cardiac Mapping and Ablation Method", Amendment filed Feb. 23, 2011 for U.S. Appl. No. 11/475,950, 28 pgs.
- Gelbart et al., "Intra-Cardiac Mapping and Ablation Method", Amendment filed Mar. 5, 2008 for U.S. Appl. No. 11/475,950, 11 pgs.
- Gelbart et al., "Intra-Cardiac Mapping and Ablation Method", Amendment filed Aug. 16, 2010 for U.S. Appl. No. 11/475,950, 22 pgs.
- Gelbart et al., "Intra-Cardiac Mapping and Ablation Method", Office Action dated Nov. 23, 2010 for U.S. Appl. No. 11/475,950, 25 pgs.
- Gelbart et al., "Intra-Cardiac Mapping and Ablation Method", Office Action dated Jun. 23, 2010 for U.S. Appl. No. 11/475,950, 18 pgs.
- Gelbart et al., "Intra-Cardiac Mapping and Ablation Method", Pre Amend filed Aug. 29, 2007 for U.S. Appl. No. 11/475,950, 42 pgs.
- Lopes et al., "High-Density Electrode-Based Medical Device System", Office Action dated Jul. 10, 2015 for U.S. Appl. No. 13/793,076, 98 pages.
- Lopes et al., "High-Density Electrode-Based Medical Device System", Office Action dated Jul. 9, 2015 for U.S. Appl. No. 13/793,213, 99 pages.
- Gelbart et al., "Apparatus and Method for Intra-Cardiac Mapping and Ablation", Office Action dated Dec. 13, 2013; Notice of Allowance dated Jul. 25, 2014 for co-pending US. Appl. No. 11/475,950, 19 pgs.
- Gelbart et al., "Medical Device for Use in Bodily Lumens, for Example an Atrium", Office Action dated Jan. 3, 2012; Office Action dated Apr. 3, 2014; Notice of Allowance dated Aug. 26, 2014 for co-pending US. Appl. No. 11/941,819, 35 pgs.
- Gelbart et al., Medical Device for Use in Bodily Lumens, for Example an Atrium, Office Action dated Jun. 20, 2014, for co-pending US. Appl. No. 13/070,215, 8 pgs.
- Gelbart et al., "Apparatus and Method for Intra-Cardiac Mapping and Ablation", Amendment filed Apr. 10, 2014; Supplemental Amendment filed Feb. 12, 2013 for co-pending US. Appl. No. 11/475,950, 21 pgs.
- Gelbart et al., "Medical Device for Use in Bodily Lumens, for Example an Atrium", Preliminary Amendment filed May 12, 2014; Preliminary Amendment filed May 2, 2014 for U.S. Appl. No. 14/229,250, 10 pgs.
- Gelbart et al., "Apparatus and Method for Intra-Cardiac Mapping and Ablation", Preliminary Amendment filed Aug. 22, 2014; Preliminary Amendment filed Mar. 5, 2013 for co-pending U.S. Appl. No. 13/785,931, 10 pgs.
- Lopes et al., "Enhanced Medical Device for Use in Bodily Cavities, for Example an Atrium", Preliminary Amendment filed Oct. 22, 2013 for co-pending U.S. Appl. No. 13/942,354, 13 pgs.
- Lopes et al., "Enhanced Medical Device for Use in Bodily Cavities, for Example an Atrium", Preliminary Amendment filed Aug. 20, 2014 for co-pending U.S. Appl. No. 13/782,889, 11 pgs.
- Lopes et al., "Enhanced Medical Device for Use in Bodily Cavities, for Example an Atrium", Preliminary Amendment filed Mar. 14, 2013 for co-pending U.S. Appl. No. 13/782,867, 8 pgs.
- Gelbart et al., "Medical Device for Use in Bodily Lumens, for Example an Atrium", Amendment filed Jul. 3, 2014; Amendment filed Apr. 2, 2012; Amendment filed Mar. 1, 2012; Amendment filed Nov. 23, 2011; Replacement drawings filed Feb. 13, 2008 for U.S. Appl. No. 11/941,819, 155 pgs.
- Gelbart et al., "Medical Device for Use in Bodily Lumens, for Example an Atrium", Preliminary Amendment filed May 12, 2014; Preliminary Amendment filed May 2, 2014 for U.S. Appl. No. 14/229,305, 12 pgs.
- Gelbart et al., "Apparatus and Method for Intra-Cardiac Mapping and Ablation", Notice of Allowance dated Oct. 23, 2014 for U.S. Appl. No. 11/475,950, 10 pgs.
- Gelbart et al., "Medical Device for Use in Bodily Lumens, for Example an Atrium", Supplemental Notice of Allowance dated Oct. 6, 2014 for U.S. Appl. No. 11/941,819, 4 pgs.
- Gelbart et al., Medical Device for Use in Bodily Lumens, for Example an Atrium, Amendment filed Sep. 22, 2014, for co-pending U.S. Appl. No. 13/070,215, 18 pgs.
- Gelbart et al., "Medical Device for Use in Bodily Lumens, for Example an Atrium", Notice of Allowance dated Nov. 13, 2014 for U.S. Appl. No. 13/070,215, 54 pages.
- Official Action issued in CN201280004400.9, dated Dec. 3, 2014.
- International Search Report dated Mar. 10, 2015, for International Application PCT/CA2014/051144; 10 pages.
- Written Opinion dated Mar. 10, 2015, for International Application PCT/CA2014/051144; 4 pages.
- Biotronik's "AICath Flutter Gold Cath for Atrial Flutter Available in EU", Sep. 19, 2013, medGadget, 3 pgs, <http://www.medgadget.com/2013/09/biotroniks-alcath-flutter-gold-cath-for-atrial-flutter-unveiled-in-europe.html> [Jun. 24, 2014 2:37:09 PM].
- Notice of Allowance issued in U.S. Appl. No. 13/793,076, dated Feb. 10, 2016.
- Final Office Action issued in U.S. Appl. No. 13/793,213, dated Feb. 26, 2016.
- Non-Final Office Action issued in U.S. Appl. No. 29/509,719, dated Feb. 25, 2016.
- Quayle issued in U.S. Appl. No. 29/509,621, dated Feb. 26, 2016.
- Quayle issued in U.S. Appl. No. 29/509,636, dated Feb. 26, 2016.
- Lopes et al., "Enhanced Medical Device for Use in Bodily Cavities, for Example an Atrium", Amendment filed Aug. 24, 2015 for U.S. Appl. No. 13/782,889, 21 pages.
- Lopes et al., "Enhanced Medical Device for Use in Bodily Cavities, for Example an Atrium", Amendment filed Aug. 28, 2015 for U.S. Appl. No. 13/782,903, 19 pages.
- Lopes et al., "Enhanced Medical Device for Use in Bodily Cavities, for Example an Atrium", Amendment filed Sep. 14, 2015 for U.S. Appl. No. 13/782,867, 25 pages.
- Lopes et al., "High-Density Electrode-Based Medical Device System", Amendment filed Oct. 9, 2015 for U.S. Appl. No. 13/793,213, 26 pages.
- Lopes et al., "High-Density Electrode-Based Medical Device System", Amendment filed Oct. 9, 2015 for U.S. Appl. No. 13/793,076, 14 pages.
- Examination Report issued in EP13172848.7, dated Sep. 21, 2015.
- Extended European Search Report issued in EP13793216.6, dated Oct. 30, 2015.

(56) **References Cited**

OTHER PUBLICATIONS

- Moisa et al., "Catheter System", Office Action dated Nov. 16, 2015 for U.S. Appl. No. 14/136,946, 92 pages.
- Office Action issued in U.S. Appl. No. 13/782,889, dated Dec. 18, 2015.
- Office Action issued in U.S. Appl. No. 13/782,903, dated Dec. 18, 2015.
- Extended European Search Report issued in EP15188407.9, dated Jan. 21, 2016.
- Lopes et al. "Enhanced Medical Device for Use in Bodily Cavities, for Example an Atrium", Office Action dated Jan. 25, 2016 for U.S. Appl. No. 13/782,867, 49 pages .
- Non-Final Office Action issued in U.S. Appl. No. 14/229,250 dated Apr. 28, 2016.
- Non-Final Office Action issued in U.S. Appl. No. 14/229,305 dated Apr. 29, 2016.
- Notice of Allowance issued in U.S. Appl. No. 13/793,076 dated Jul. 7, 2016.
- Notice of Allowance issued in U.S. Appl. No. 13/793,213 dated Aug. 10, 2016.
- Non-Final Office Action issued in U.S. Appl. No. 13/942,354 dated Aug. 4, 2016.
- Notice of Allowance issued in U.S. Appl. No. 14/136,946 dated May 12, 2016.
- Notice of Allowance issued in U.S. Appl. No. 13/782,867 dated Aug. 12, 2016.
- Notice of Allowance issued in U.S. Appl. No. 13/782,903 dated Jul. 6, 2016.
- Corrected Notice of Allowance issued in U.S. Appl. No. 13/782,903 dated Jul. 19, 2016.
- Notice of Allowance issued in U.S. Appl. No. 13/782,889, dated Aug. 25, 2016.
- Summons to Attend Oral Proceedings issued in European Appl. No. 13172848.7, dated Sep. 1, 2016.
- Notice of Allowance issued in U.S. Appl. No. 29/509,636, dated Sep. 27, 2016.
- Notice of Allowance issued in U.S. Appl. No. 29/509,621, dated Sep. 27, 2016.
- European Search Report issued in European Patent Application No. 14871405.8 dated Jul. 5, 2017.
- Office Action issued in copending U.S. Appl. No. 14/564,463 dated Jul. 17, 2017.
- Response to Quayle Action filed in copending U.S. Appl. No. 14/713,190 dated Jul. 24, 2017.
- Preliminary Amendment filed in copending U.S. Appl. No. 14/521,692 dated Oct. 23, 2014.
- Copending U.S. Appl. No. 15/663,077, filed Jul. 28, 2017.
- Preliminary Amendment filed in copending U.S. Appl. No. 15/663,077 dated Aug. 8, 2017.
- Gelbart et al., "Medical Device for Use in Bodily Lumens, for Example an Atrium", Amendment filed in co-pending U.S. Appl. No. 14/521,692 dated Mar. 31, 2017, 9 pgs.
- Office Action issued in Chinese Patent Application No. 201510432392.3 dated Mar. 8, 2017. English concise Explanation of Relevance provided.
- Lopes et al., "Intra-Cardiac Procedure Device", Amendment filed in co-pending U.S. Appl. No. 29/509,636, filed Jul. 22, 2016, 5 pgs.
- Lopes et al., "Intra-Cardiac Procedure Device", Amendment filed in co-pending U.S. Appl. No. 29/509,636 dated Nov. 17, 2016, 3 pgs.
- Office Action issued in U.S. Appl. No. 14/564,463 dated Feb. 28, 2017.
- Lopes et al., "Intra-Cardiac Procedure Device", Amendment filed in co-pending U.S. Appl. No. 29/509,621 dated Jul. 22, 2016, 5 pgs.
- Lopes et al., "Intra-Cardiac Procedure Device", Amendment filed in co-pending U.S. Appl. No. 29/509,621 dated Nov. 17, 2016, 3 pgs.
- Notice of Allowance issued in U.S. Appl. No. 13/942,354 dated Feb. 10, 2017.
- Lopes et al., "Enhanced Medical Device for Use in Bodily Cavities, for Example an Atrium", Preliminary Amendment filed in co-pending U.S. Appl. No. 15/299,640 dated Oct. 21, 2016, 4 pgs.
- Lopes et al., "Enhanced Medical Device for Use in Bodily Cavities, for Example an Atrium", Preliminary Amendment filed in co-pending U.S. Appl. No. 15/299,640 dated Dec. 9, 2016, 11 pgs.
- Gelbart et al., "Intra-Cardiac Mapping and Ablation Method", Amendment filed in co-pending U.S. Appl. No. 11/475,950 dated Feb. 12, 2013, 4 pgs.
- Moisa et al., "Catheter System", Preliminary Amendment filed in co-pending U.S. Appl. No. 15/254,130 dated Sep. 19, 2016, 22 pgs.
- Gelbart et al., "Apparatus and Method for Intra-Cardiac Mapping and Ablation", Preliminary Amendment filed in co-pending U.S. Appl. No. 14/804,924 dated Jul. 30, 2015, 5 pgs.
- Gelbart et al., "Apparatus and Method for Intra-Cardiac Mapping and Ablation", Preliminary Amendment filed in co-pending U.S. Appl. No. 14/804,810 dated Jul. 30, 2015, 10 pgs.
- Gelbart et al., "Medical Device for Use in Bodily Lumens, for Example an Atrium", Preliminary Amendment filed in co-pending U.S. Appl. No. 14/713,190 dated May 15, 2015, 3 pgs.
- Gelbart et al., "Medical Device for Use in Bodily Lumens, for Example an Atrium", Preliminary Amendment filed in co-pending U.S. Appl. No. 14/713,190 dated Jun. 16, 2015, 7 pgs.
- Gelbart et al., "Medical Device for Use in Bodily Lumens, for Example an Atrium", Preliminary Amendment filed in co-pending U.S. Appl. No. 14/713,114 dated Jun. 16, 2015, 8 pgs.
- Office Action issued in co-pending U.S. Appl. No. 14/521,692 dated Jan. 10, 2017.
- Gelbart et al., "Medical Device for Use in Bodily Lumens, for Example an Atrium", Amendment filed in co-pending U.S. Appl. No. 14/229,305 dated Sep. 27, 2016, 15 pgs.
- Notice of Allowance issued in co-pending U.S. Appl. No. 14/229,305 dated Nov. 8, 2016.
- Gelbart et al., "Medical Device for Use in Bodily Lumens, for Example an Atrium", Amendment filed in co-pending U.S. Appl. No. 14/229,250 dated Sep. 27, 2016, 13 pgs.
- Notice of Allowance issued in co-pending U.S. Appl. No. 14/229,250 dated Dec. 7, 2016.
- Moisa et al., "Catheter System", Amendment filed in co-pending U.S. Appl. No. 14/136,946 dated Apr. 18, 2016, 19 pgs.
- Lopes et al., "Enhanced Medical Device for Use in Bodily Cavities, for Example an Atrium", Amendment filed in co-pending U.S. Appl. No. 13/942,354 dated Jan. 4, 2017, 23 pgs.
- Lopes et al., "High-Density Electrode-Based Medical Device System", Preliminary Amendment filed in co-pending U.S. Appl. No. 13/793,076 dated May 26, 2016, 15 pgs.
- Lopes et al., "High-Density Electrode-Based Medical Device System", Amendment filed in co-pending U.S. Appl. No. 13/793,076 dated May 9, 2016, 15 pgs.
- Gelbart et al., "Apparatus and Method for Intracardiac Mapping and Ablation", Preliminary Amendment filed in co-pending U.S. Appl. No. 13/785,931 dated Mar. 5, 2013, 2 pgs.
- Decision to Refuse a European Patent Application issued in European Patent Application No. 13172848.7 dated Feb. 22, 2017.
- Lopes et al., "High-Density Electrode-Based Medical Device System" Amendment filed in co-pending U.S. Appl. No. 13/793,213 dated May 26, 2016, 39 pgs.
- Lopes et al., "Enhanced Medical Device for Use in Bodily Cavities, for Example an Atrium", Amendment filed in co-pending U.S. Appl. No. 13/782,867 dated May 17, 2016, 39 pgs.
- Lopes et al., "Enhanced Medical Device for Use in Bodily Cavities, for Example an Atrium", Amendment filed in co-pending U.S. Appl. No. 13/782,889 dated May 17, 2016, 51 pgs.
- Lopes et al., "High-Density Electrode-Based Medical Device System", Preliminary Amendment filed in co-pending U.S. Appl. No. 15/287,988 dated Nov. 23, 2016, 9 pgs.
- Notice of Allowance issued in copending U.S. Appl. No. 14/521,692 dated May 19, 2017.
- Office Action issued in copending U.S. Appl. No. 14/713,114 dated Jun. 1, 2017.
- Quayle Action issued in copending U.S. Appl. No. 14/713,190 dated May 30, 2017.
- Office Action issued in German Application No. 112008003108.8 dated May 8, 2017. English translation provided.
- Amendment filed in copending U.S. Appl. No. 14/564,463, filed May 25, 2017.

(56)

References Cited

OTHER PUBLICATIONS

Copending U.S. Appl. No. 15/697,744, filed Sep. 7, 2017.
Copending U.S. Appl. No. 15/725,731, filed Oct. 5, 2017.
Copending U.S. Appl. No. 15/725,662, filed Oct. 5, 2017.
Preliminary Amendment filed in copending U.S. Appl. No. 15/697,744 dated Sep. 21, 2017.
Copending U.S. Appl. No. 15/784,555, filed Oct. 16, 2017.
Copending U.S. Appl. No. 15/784,647, filed Oct. 16, 2017.
Copending U.S. Appl. No. 15/784,722, filed Oct. 16, 2017.
Copending U.S. Appl. No. 15/784,775, filed Oct. 16, 2017.
Amendment filed in copending U.S. Appl. No. 14/564,463 dated Oct. 17, 2017.
Notice of Allowance issued in copending U.S. Appl. No. 14/713,114 dated Nov. 1, 2017.
Notice of Allowance issued in copending U.S. Appl. No. 14/564,463 dated Nov. 9, 2017.
Preliminary Amendment filed in copending U.S. Appl. No. 15/784,555 dated Nov. 7, 2017.
Preliminary Amendment filed in copending U.S. Appl. No. 15/784,775 dated Nov. 7, 2017.
Preliminary Amendment filed in copending U.S. Appl. No. 15/784,722 dated Nov. 7, 2017.
Preliminary Amendment filed in copending U.S. Appl. No. 15/725,731 dated Oct. 24, 2017.
Preliminary Amendment filed in copending U.S. Appl. No. 15/784,647 dated Nov. 7, 2017.

Preliminary Amendment filed in copending U.S. Appl. No. 15/725,662 dated Oct. 24, 2017.
Office Action issued in copending U.S. Appl. No. 14/804,924 dated Nov. 17, 2017.
Office Action issued in copending U.S. Appl. No. 14/804,810 dated Nov. 30, 2017.
Examination Report issued in European Application No. 13793216.6 dated Nov. 24, 2017.
Amendment filed in copending U.S. Appl. No. 14/713,114 dated Aug. 23, 2017.
Notice of Allowance issued in copending U.S. Appl. No. 14/713,190 dated Aug. 28, 2017.
Amendment filed in copending U.S. Appl. No. 14/804,924 dated Feb. 27, 2018.
Amendment filed in copending U.S. Appl. No. 14/804,810 dated Feb. 27, 2018.
Notice of Allowance issued in copending U.S. Appl. No. 14/804,924 dated Mar. 27, 2018.
Notice of Allowance issued in copending U.S. Appl. No. 14/804,810 dated Mar. 30, 2018.
Office Action issued in Chinese Application No. 201510432392.3 dated May 18, 2018. Concise Explanation of Relevance provided.
Examination Report issued in European Application No. 15188407.9 dated Dec. 11, 2017.
Office Action issued in Chinese Application No. 201510432392.3 dated Nov. 17, 2017. English translation and Concise Explanation of Relevance provided.

* cited by examiner

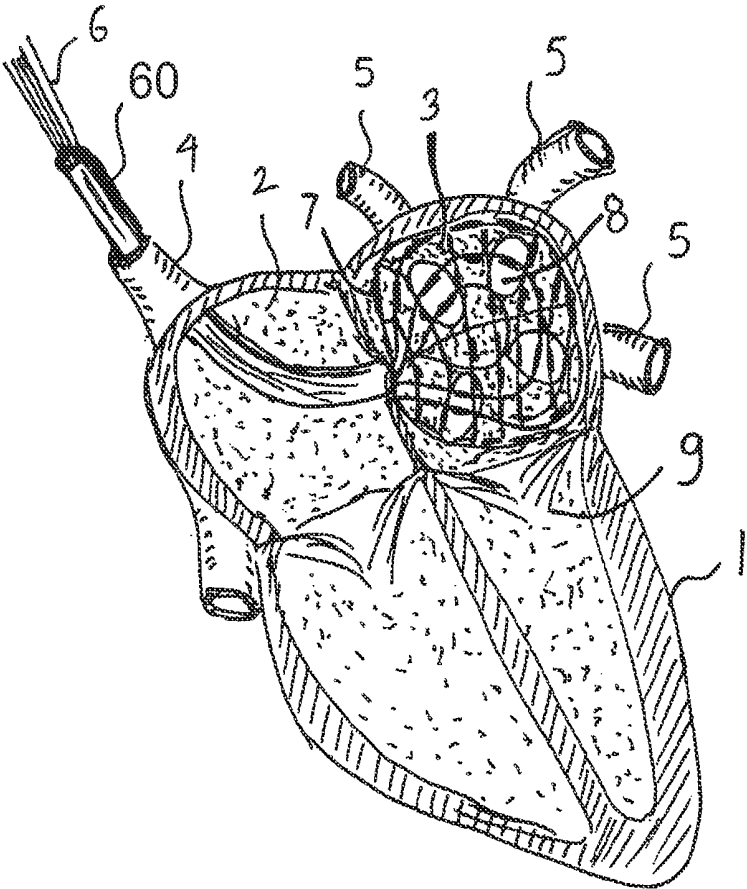

Fig 1

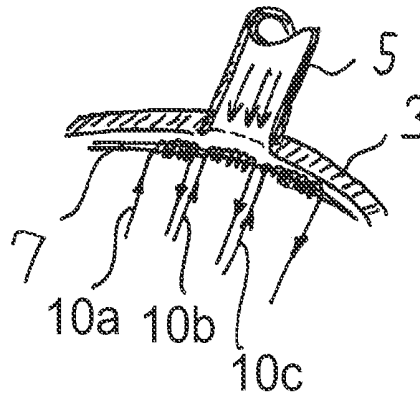

Fig 2

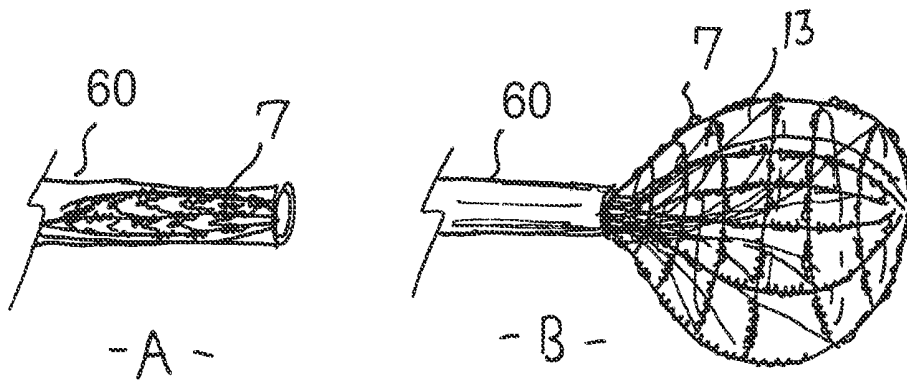

Fig 3

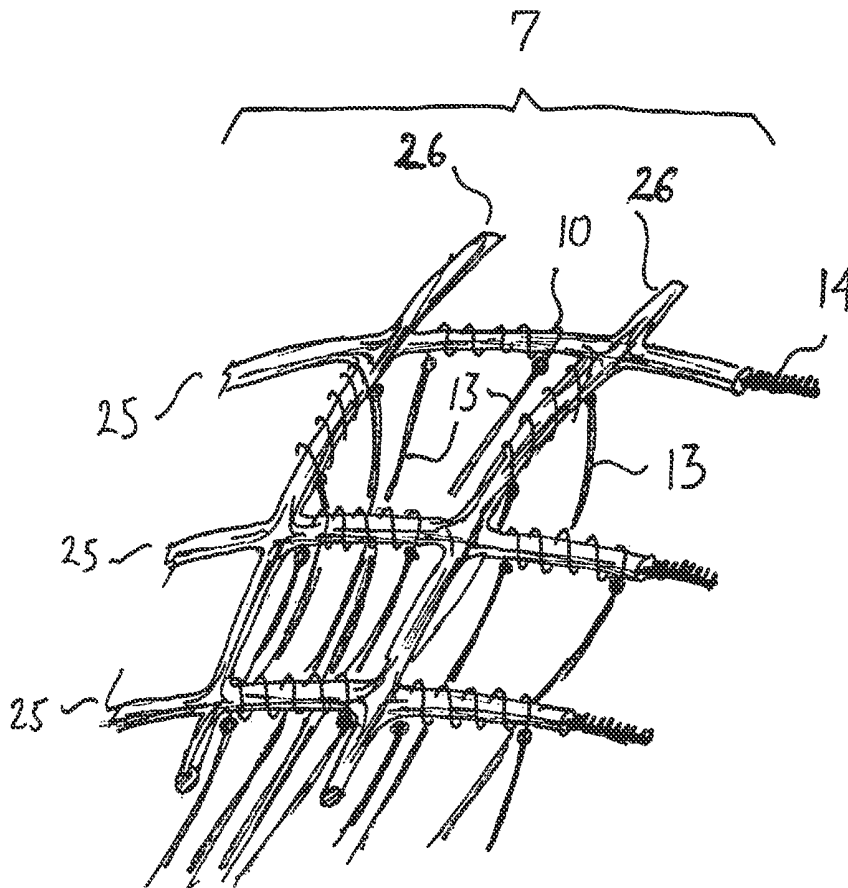

Fig 4

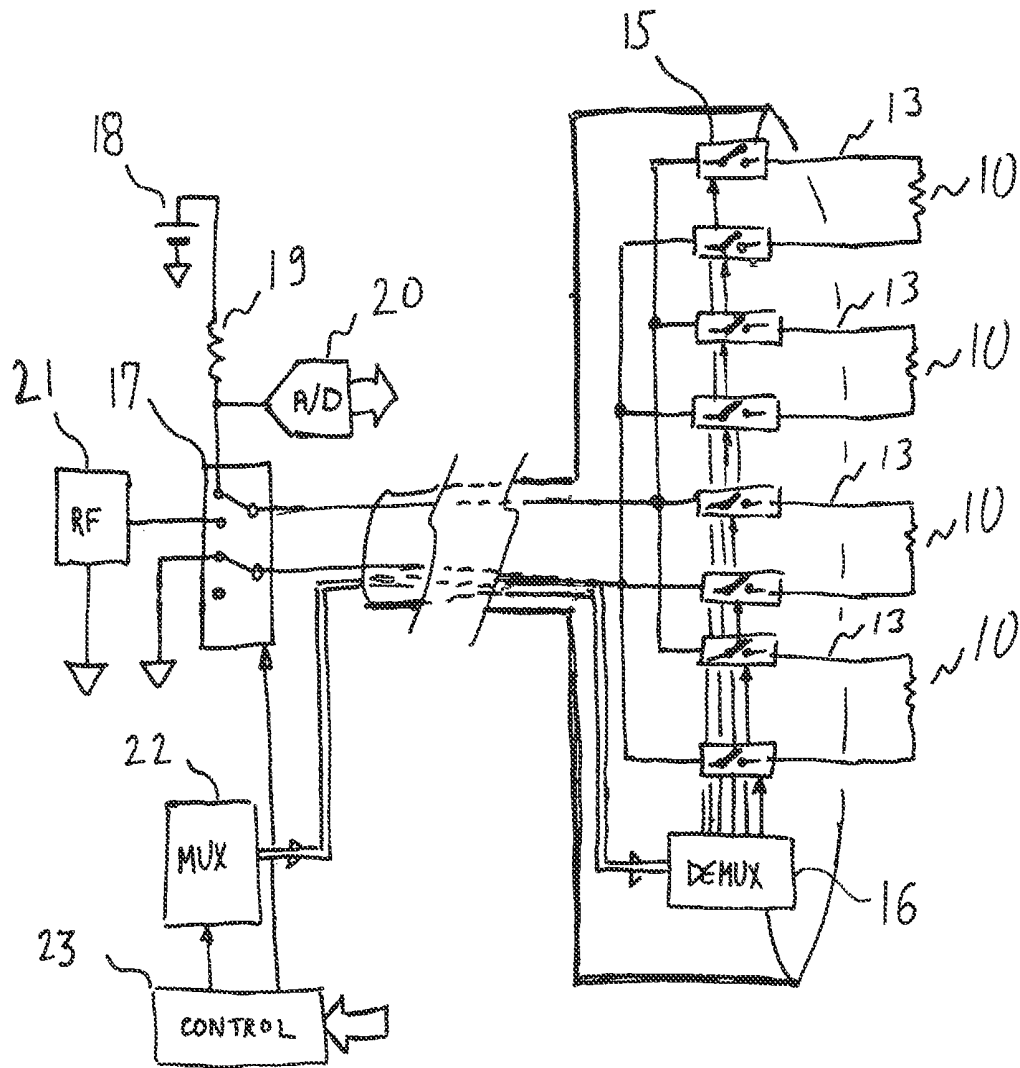

Fig 5

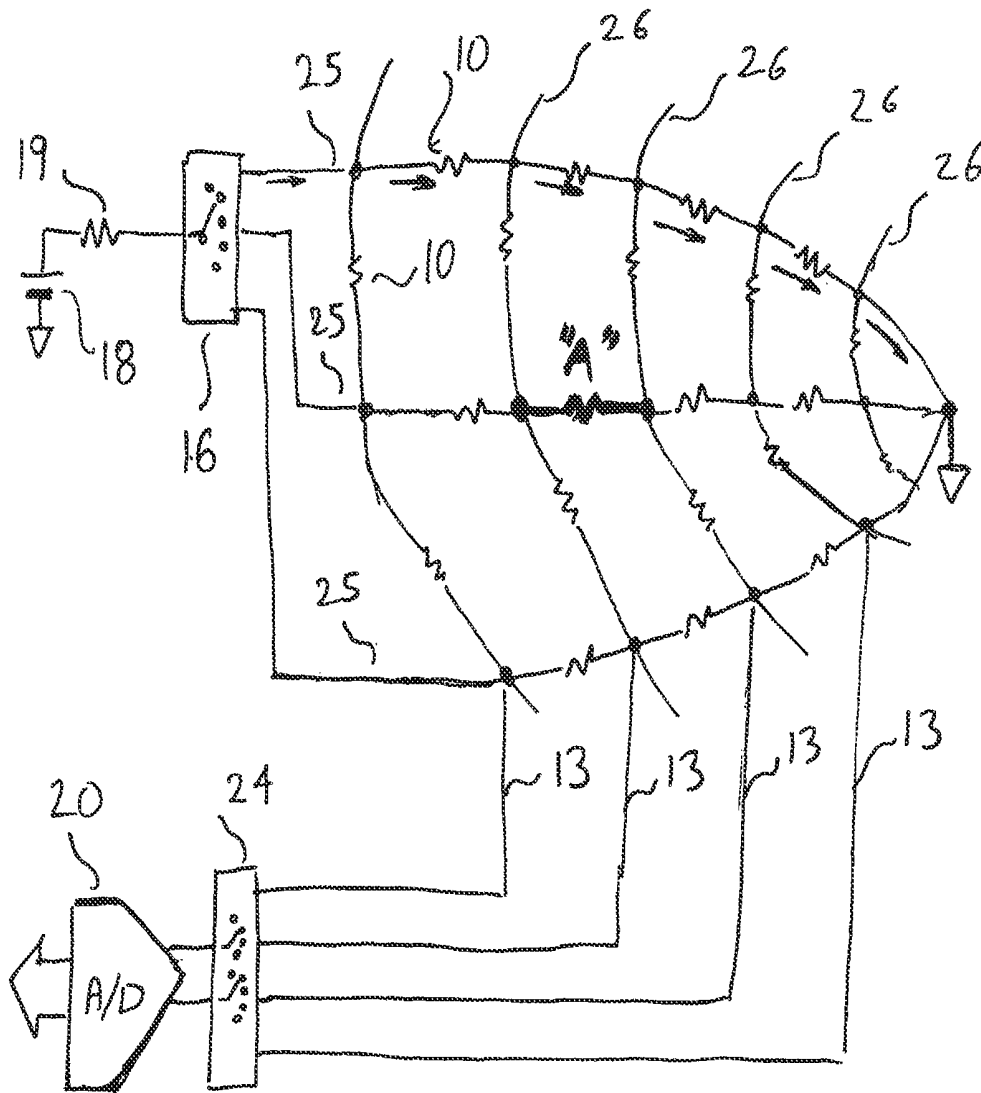

Fig 6

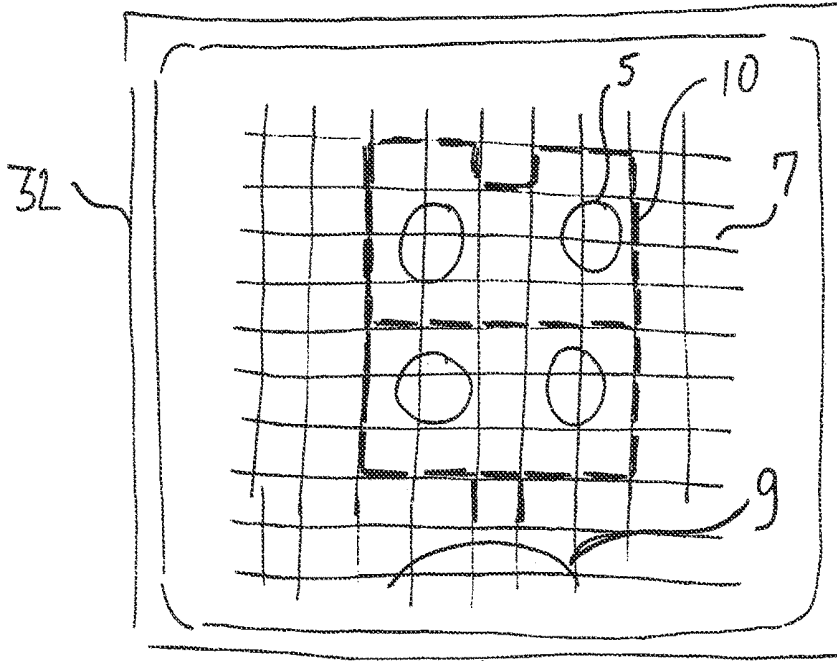

Fig 7

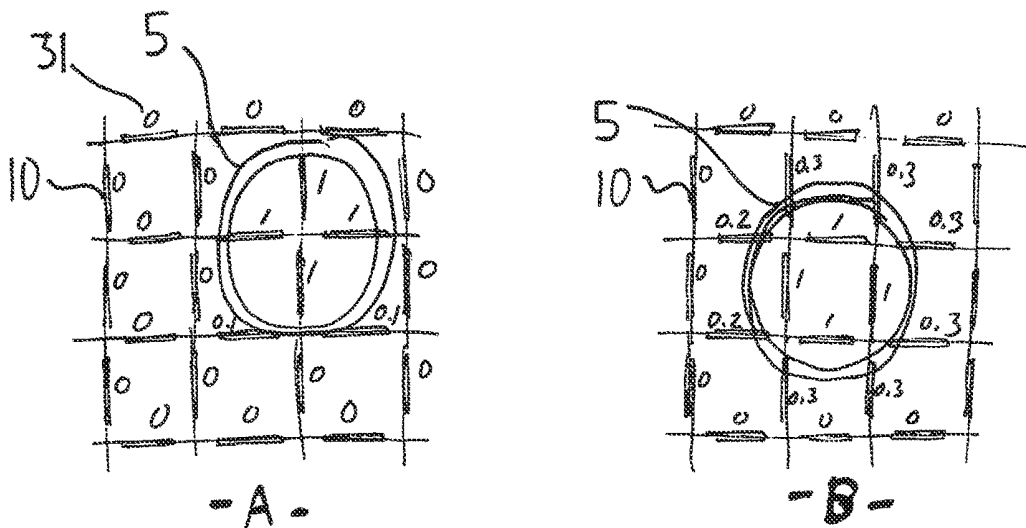

Fig 8

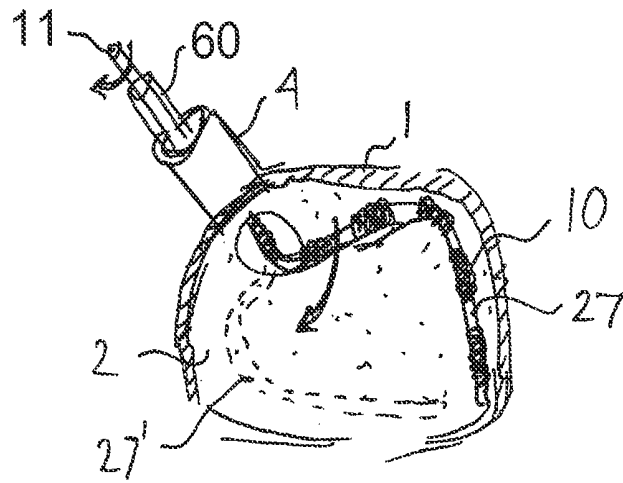

Fig 9

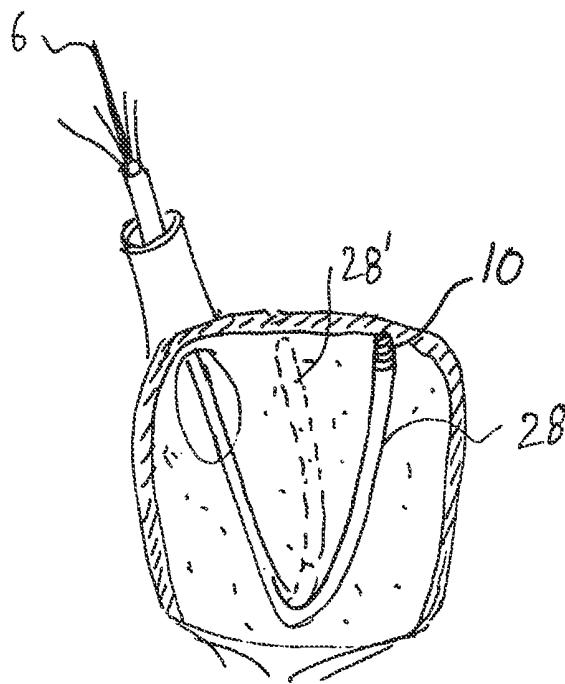

Fig 10

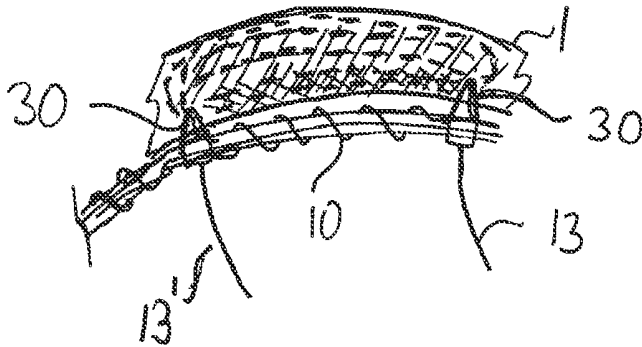

Fig 11

APPARATUS AND METHOD FOR INTRA-CARDIAC MAPPING AND ABLATION

CROSS-REFERENCE TO RELATED APPLICATION

This application is a continuation-in-part of prior U.S. patent application Ser. No. 11/475,950, filed Jun. 28, 2006, the entire disclosure of which is hereby incorporated herein by reference.

TECHNICAL FIELD

This disclosure generally relates to minimally invasive heart surgery, also known as percutaneous cardiac surgery and particularly relates to percutaneous mapping and ablation.

BACKGROUND

Atrial fibrillation is a well known disorder in which spurious electrical signals cause an irregular heart beat. The disorder has a well known cure known as the Maze procedure, in which a border is ablated around the sources of the spurious signals, typically in the left atrium but sometimes in the right atrium. The procedure is very commonly performed under direct vision, but difficult to perform percutaneously via a catheter because of the associated risk. Any error in navigation inside the heart can cause fatal damage. The key to a percutaneous procedure is mapping of the inside of the right and left atrium. Access to the right atrium is simple via the superior vena cava; the left atrium can be reached i) by perforating the transatrial septum, ii) via the aorta and the left ventricle or iii) via the pulmonary veins.

Prior approaches to map the inside of the atrium relied on electrical activity picked up from the atrium wall. These approaches require intimate electrical contact, not always possible because of scar tissue and deposits. These approaches may fail to accurately map the edges of the openings where the veins enter the atrium; information that is useful for correct placement of the ablation pattern. Other mapping methods, such as using an array of ultrasonic transducers, are not practical since such arrays typically will not fit through a catheter of a reasonable size (8-10 mm diameter). A superior mapping apparatus and method, that enables safe execution of the Maze and other intra-cardiac procedures is desirable.

A good survey article on the subject is: "Ablation of Atrial Fibrillation: Energy Sources and Navigation Tools: A survey" by Ruediger Becker and Wolfgang Schoels (J. of Electrocardiology, Vol 37, 2004, pp 55-61). The article includes an extensive bibliography.

SUMMARY

Embodiments of an intra-cardiac mapping system are based on locating openings or ports and valves through which blood flows in or out of the heart chambers. For many procedures, such as ablation to cure atrial fibrillation, accurately locating the pulmonary veins and the mitral valve allows performance of a Maze procedure. The openings, ports and valves may be located based on the convective cooling effect of the blood flow. The mapping can be performed by a catheter-deployed expandable net or a scanning catheter. The same net or catheter can also perform the ablation procedure.

In one embodiment, a method for intra-cardiac mapping comprises: introducing a plurality of flow sensors into an intra-cardiac cavity; locating points in a wall forming said cavity based on sensing blood flow; and mapping said walls of said cavity based on said points. The method for intra-cardiac mapping may include said blood flow being sensed by its convective cooling effect on a heated sensor. The method for intra-cardiac mapping may include said sensing being done by a steerable linear array. The method for intra-cardiac mapping may include said mapping being used for treating atrial fibrillation by RF ablation. The method for intra-cardiac mapping may include being used for treating atrial fibrillation by microwave ablation. The method for intra-cardiac mapping may include said mapping being used for treating atrial fibrillation by cryogenic ablation. The method for intra-cardiac mapping may include said mapping being used for treating atrial fibrillation by laser ablation. The method for intra-cardiac mapping may include said blood flow being sensed by the resistance change of a heated resistive wire.

In another embodiment, a method for intra-cardiac mapping comprises: introducing an expandable sensing mesh into said cavity via a catheter; using said mesh to locate openings in walls forming said cavity based on the convective heat transfer of blood flowing through said holes; and mapping inside of said cavity based on location of said openings. The method for intra-cardiac mapping may include said blood flow being sensed by its convective cooling effect on a heated sensor. The method for intra-cardiac mapping may include said sensing being done by a steerable linear array. The method for intra-cardiac mapping may include said mapping being used for treating atrial fibrillation by RF ablation. The method for intra-cardiac mapping may include said mapping being used for treating atrial fibrillation by microwave ablation. The method for intra-cardiac mapping may include said mapping being used for treating atrial fibrillation by cryogenic ablation. The method for intra-cardiac mapping may include said mapping being used for treating atrial fibrillation by laser ablation. The method for intra-cardiac mapping may include said blood flow being sensed by the resistance change of a heated resistive wire. The method for intra-cardiac mapping may include said mesh comprising small coils of nickel wire wound on a mesh of a flexible insulator. The method for intra-cardiac mapping may include an electronic switch used to minimize the number of electrical wires passing through said catheter.

In yet another embodiment, a method for treating atrial fibrillation comprises: introducing at least one flow sensor into an intra-cardiac cavity; locating points in a wall forming said cavity based on sensing blood flow; mapping walls of said cavity based on said points; and ablating a pattern into walls of said cavity based on said mapping. The method for treating atrial fibrillation may include said blood flow being sensed by its convective cooling effect on a heated sensor. The method for treating atrial fibrillation may include said sensing being done by a steerable linear array. The method for treating atrial fibrillation may include said mapping being used for treating atrial fibrillation by RF ablation. The method for treating atrial fibrillation may include said mapping being used for treating atrial fibrillation by microwave ablation. The method for treating atrial fibrillation may include said mapping being used for treating atrial fibrillation by cryogenic ablation. The method for treating atrial fibrillation may include said mapping being used for treating atrial fibrillation by laser ablation. The method for treating atrial fibrillation may include said blood flow being sensed

by the resistance change of a heated resistive wire. The method for treating atrial fibrillation may include said flow sensors also acting as electrodes for said ablation. The method for treating atrial fibrillation may include said flow sensor being based on temperature sensing and a same sensor being used to monitor temperature during said ablation. The method for treating atrial fibrillation may include said ablation being unipolar. The method for treating atrial fibrillation may include said ablation being bipolar. The method for treating atrial fibrillation may include said ablated pattern being a Maze procedure.

BRIEF DESCRIPTION OF THE DRAWINGS

In the drawings, identical reference numbers identify similar elements or acts. It is to be understood that the attached drawings are for purposes of illustrating the concepts of the invention and may not be to scale. For example, the sizes, relative positions, shapes, and angles of or associated with elements in the drawings are not necessarily drawn to scale, and some elements may be arbitrarily enlarged and positioned to improve drawing legibility. Further, the particular shapes of the elements as drawn may differ from their actual shapes and, in this regard, may be selected instead of the respective actual shapes for ease of recognition in the drawings.

FIG. 1 is a cross sectional view of the heart showing the mapping mesh deployed in the left atrium.

FIG. 2 is a cross sectional view of the sensing device.

FIGS. 3A and 3B are isometric views of the mesh in both folded and expanded position.

FIG. 4 is an isometric enlarged view of a portion of the mesh.

FIG. 5 is an electrical schematic of a mapping and ablation system.

FIG. 6 is an electrical schematic of a simplified mapping system.

FIG. 7 is a schematic view of the display console of the system.

FIGS. 8A and 8B are graphical views of a mapping that illustrate an interpolation principle.

FIG. 9 is a cross sectional view of an alternate embodiment, using mechanical or manual scanning in one axis.

FIG. 10 is a cross sectional view of an alternate embodiment, using mechanical scanning in two dimensions.

FIG. 11 shows the use of the invention for bipolar ablation.

DETAILED DESCRIPTION

In the following description, certain specific details are set forth in order to provide a thorough understanding of various disclosed embodiments. However, one skilled in the relevant art will recognize that embodiments may be practiced without one or more of these specific details, or with other methods, components, materials, etc. In other instances, well-known structures associated with apparatuses and methods for intra-cardiac mapping and ablation have not been shown or described in detail to avoid unnecessarily obscuring descriptions of the embodiments.

Unless the context requires otherwise, throughout the specification and claims which follow, the word "comprise" and variations thereof, such as, "comprises" and "comprising" are to be construed in an open, inclusive sense, that is as "including, but not limited to."

Reference throughout this specification to "one embodiment" or "an embodiment" means that a particular feature,

structure or characteristic described in connection with the embodiment is included in at least one embodiment. Thus, the appearances of the phrases "in one embodiment" or "in an embodiment" in various places throughout this specification are not necessarily all referring to the same embodiment. Furthermore, the particular features, structures, or characteristics may be combined in any suitable manner in one or more embodiments.

As used in this specification and the appended claims, the singular forms "a," "an," and "the" include plural referents unless the content clearly dictates otherwise. It should also be noted that the term "or" is generally employed in its non-exclusive sense including "and/or" unless the content clearly dictates otherwise.

The headings and Abstract of the Disclosure provided herein are for convenience only and do not interpret the scope or meaning of the embodiments.

FIG. 1 shows a sensing and ablation mesh 7 inserted into a left atrium 3 of a heart 1 according to one illustrated embodiment.

By way of example, the mesh 7 may be delivered via a catheter 60 inserted via a superior vena cava 4 and penetrating a transatrial septum from a right atrium 2 of the heart 1. The mesh 7 is communicatively coupled to the rest of the system, for example, by electrical wires 6.

Before any ablation takes place, the inside of the left atrium 3 is mapped in order to locate the openings or ports 8 leading to the pulmonary veins 5, as well as the mitral valve 9. A typical Maze procedure ablates a "fence" around openings or ports 8 to stop propagation of spurious electrical signals which cause the heart 1 to contract at the wrong times.

The mapping may locate some or all of the openings or ports 8 through which blood flows in and out of the left atrium 3, as the Maze procedure is mainly concerned with the location of these openings or ports 8. By the way of example, in the left atrium 3, the four openings or ports 8 leading to the pulmonary veins 5 as well as the mitral valve 9 may be located. The location of these openings or ports 8 may be based on the fact that the convective cooling effect of the blood is significant, and a slightly heated mesh 7 pressed against the walls of the left and/or right atrium 3, 2 will be cooler at the areas which are spanning the openings or ports 8 carrying blood.

FIG. 2 shows the ablation mesh 7 covered by miniature heating and/or temperature sensing elements 10a-10c flow (collectively 10, only three illustrated in the figure). Each one of these elements 10a-10c comprises a few turns of a resistive wire, for example nickel wire, wound on an electrically insulated mesh. A low current is passed through each element 10, raising a temperature of the element 10 by about 1 degree C. above normal blood temperature. A first element 10b, which lies across an opening or port 8 of one of the pulmonary veins 5, will be cooled by blood flow. The other elements are against a wall 3 and hence do not lie across any of the openings or ports 8.

By identifying the relatively cooler elements 10a, 10c on the mesh 7, the location of the openings or ports 8 may be found.

This method does not require intimate contact with the wall 3, as the cooling effect is significant even a few millimeters away from the opening.

The same elements 10 can be used as ablation electrodes during an ablation stage. It was found that the power required to raise the temperature of the mesh 7 by a small but easily detectable amount is very small, on the order of 10-50 mW per element 10. If the elements 10 are made of a

material that has a significant change in resistance with temperature, the temperature drop can be sensed by measuring a voltage across the element 10 when driven by a constant current. A good choice for element material is nickel wire, which is inert, highly resistive and has a significant temperature coefficient of resistance (about 0.6% per deg C.). Since the resistance of the elements 10 is low (typically 0.1-1 ohm), the electrical noise is very low and temperature changes as low as 0.1 deg can be easily detected. For even higher detection sensitivity, the voltage waveform can be sampled in synchronization with the heart rate or the average voltage removed and only the change amplified. Such methods are referred to as "AC coupling". A further refinement to reduce the electrical noise is to pass the signal through a digital band pass filter having a center frequency tracking the heart rate. To avoid any potential tissue damage, the temperature of the elements 10 of the mesh 7 is only slightly above the blood temperature, typically 0.1-3 degrees C. above blood temperature.

FIG. 3A shows the mesh 7 in a compressed configuration "A" and FIG. 3B shows the mesh 7 in an expanded configuration "B". Since the mesh 7 has to fit into a catheter 60, the mesh 7 should be very flexible. Besides elements 10 discussed earlier, there is also a large number of leads 13 coming out of the mesh 7. Leads 13 can be loose, as shown in FIG. 3B, or may be bonded to the mesh 7. To avoid feeding a large number of wires all the way to an operating console, an electronic selector switch may be employed, which may, for example, be mounted in the catheter 60. This reduces the number of electrical wires from over 100 to about 10. The mesh 7 can be self-expanding (elastic) or balloon-expandable. Self expanding allows normal blood flow during the procedure. For balloon expandable devices, the expansion balloon should be removed before the mapping, to avoid blocking the flow of blood.

FIG. 4 shows the mesh 7 in more detail. Insulated longitudinal (i.e., parallel to catheter) wires 25 are crossed by cross wires 26. Each section of the mesh 7 is covered by a few turns of thin (0.05-0.2 mm) nickel wire 10 having leads 13. The leads 13 can be regular thin copper wire. The longitudinal wires 25 can be stiffer than the cross wires 26, therefore can be made self-expanding by incorporating a core 14 made of coiled flexible metal wire such as Nitinol. A metallic core may interfere with the ablation process at higher frequencies and can be replaced by simply making the longitudinal wires 25 of a polymeric material thicker than the cross wires 26. The cross wires 26, which may form rings around wires 25, should be very flexible to compress into the catheter 60. The cross wires 26 could incorporate a very thin wire or coiled up wire. Use of a flexible mesh 7 not only allows percutaneous delivery, but also permits the mesh 7 to follow the atrial volume change each heartbeat. The mesh 7 should stay in contact with or close to the atrial wall during the cardiac cycle, otherwise the measurement and the ablation may only be performed during parts of the cardiac cycle. The diameter of the longitudinal wires 25 and cross wires 26 are typically 0.2-1 mm. The mesh 7 may include about 10-20 longitudinal wires 25 and about 10-20 cross wires 26. The insulation can be any polymeric material such as thin enamel or polymer coating. Practically any polymer can be used, as the maximum temperature it will be subject to, including during the ablation phase, is around 100 degrees C.

FIG. 5 shows an electrical system, according to one illustrated embodiment. The elements 10 may be resistive heaters wound on the mesh 7. Each of the elements 10 is connected by electronic element switches 15 (typically FET

or MOS-FET type) to a single pair of wires leading out of the body to a mode selection switch 17. Element switches 15 are selected by demultiplexer or selector 16. The de-multiplexer or selector 16 is controlled by a small number of wires or even a single wire if data is sent in serial form, by a multiplexer 22. Element switches 15 and de-multiplexer or selector 16 may be built into the catheter 60, which may, for example, be located near the point of deployment of the mesh 7. The element switches 15 have to carry significant power during the ablation phase.

The mode selection 17 selects between a mapping mode (position shown in the drawing) and an ablation mode (second position of switch). In the mapping mode, a current is created by a voltage source 18 and resistor 19 (e.g., forming a constant current source) and routed into a selected element 10 by the element switches 15. For each measurement, the two element switches 15 that are connected to the scanned element 10 are in an enabled state (ON), the rest of the element switches being in a disabled state (OFF). The voltage drop across an element 10 is measured by an analog to digital (A/D) converter 20 and fed to a control computer 23. For greater accuracy, four terminal sensing can be employed. In a preferred embodiment, the detection is AC coupled, therefore the DC voltage drops along the wires are of no consequence, and no four-terminal sensing is needed. For AC coupling, the control computer 23 may include a 0.5 Hz low pass filter, which may be implemented in software. The slight disadvantage of the AC coupled method approach is speed, as the low signal frequency (e.g., about 1 Hz), requires a few seconds per measurement. Other temperature sensors and/or approaches, such as thermistors or thermocouples, can be used in conjunction with the elements 10. Mapping is achieved by turning on all of the elements 10 (e.g., sequentially) and measuring the temperature of each. A map may be formed in the control computer 23 and the lower temperature spots on the mesh correspond to the openings or ports 8 leading to the veins or valves.

When the mode selection switch 17 is in the ablation mode, a generator 21 (e.g., Radio Frequency (RF)) is connected (e.g., sequentially) to selected elements 10 by the control computer 23 addressing the multiplexer 22 which controls the element switches 15 via the de-multiplex selector 16. The complete operation, including scanning and ablation, can be completed in less than 5 minutes. The configuration illustrated in FIG. 5 implies unipolar ablation; however bipolar ablation can be used as well and is discussed below. Clearly other sources of ablation can be used besides RF. Frequencies from DC to microwaves can be used, as well as delivery of laser power via optical fibers or cryogenics via thin tubes. For laser ablation element switches 15 are optical switches, while for cryogenic ablation the element switches 15 are valves, and in some embodiments may take the form of heated elements such as resistive wires.

During ablation it is desirable to monitor the temperature of the mode selection switch 17 to the mapping position several times during the ablation procedure. The measured temperatures can be displayed on a display 32 (FIG. 7). RF ablation is typically performed at frequencies of 100 KHz-1 MHz and power levels which depend on the size of the elements 10, but can be as high as 100 W. Various RF ablation techniques and equipment are well known in the art.

FIG. 6 shows an embodiment in which the mapping system is separate from the ablation system. In this system, the mesh 7 has very few connecting wires. As illustrated, each longitudinal wire 25 has a single output wire and each cross wire 26 has a single output wire 13. For a 10x10 mesh

7 with 100 nodes, only twenty-one wires are needed (ten plus ten plus ground wire), instead of two hundred wires. This allows all wires to be brought directly out of the catheter 60. This also allows placement of selector switches 16 and 24 together with the control system. For example, if the element marked as "A" is selected; a current is selected to run through the longitudinal wire 25 which includes element A. The voltage drop is sensed by the two circumferential wires 13 that connect directly to A. Since no current flows in the other elements at the time of measurement, the voltage drop is only caused by element A. It is sensed by A/D converter 20 via double pole selector 24.

After a map is established, it is displayed on a display screen 32 as shown in FIG. 7. The surgeon can select which elements 10 will cause tissue ablation in the atrium. The pattern formed is along the line of the standard Maze procedure. The location of the pulmonary veins 5 and the mitral valve 9 is inferred from the temperature data and drawn on the display screen.

FIGS. 8A and 8B demonstrate the principle of accurate location of the veins and valves even if the grid is relatively coarse. The exact location can be interpolated based on the fact that when only part of the element 10 is exposed to the blood flow. By the way of example, if the temperature of the mesh 7 is 1 degree C. above blood temperature and equals the blood temperature under normal blood flow (this was experimentally verified), the temperatures of a group of elements 10 will be as shown in FIG. 8A when aligned with the opening or port 8 of vein 5. The number near each element 10 is the temperature drop. When moved, some of the elements 10 will only be partially positioned in the flow path under vein 5, as shown by FIG. 8B. The temperatures of those elements 10 will be between 0 and 1 degree above blood temperature.

The exact temperature drop between 0 to 1 corresponds with the exact shift. This allows accurate determination of the location and size of each opening or port 8, data used by the control computer 23 to draw the map shown in FIG. 7. A grid spacing of 10 mm allows about 1 mm accuracy.

An alternative to a full mesh is a partial mesh, or even a single sensor, that is mechanically scanned across the area to be mapped. FIG. 9 shows a linear sensor array 27 pushed into the atrium 2 via vein 4 by the catheter 60. The linear sensor array 27 has a linear array of elements 10 similar to those used in the full mesh 7. After a linear mapping is performed the linear sensor array 27 is rotated (as shown by broken line 27') a small amount (10-20 degrees) by stem 11 (similar to electrical wires 6) and a new scan is performed. The same procedures previously described may be used for ablation.

FIG. 10 shows the use of a single steerable catheter 28 as a mapping and ablation tool. Steerable catheters are controlled remotely by mechanical, magnetic, hydraulic or other means. A steerable catheter 28 can be used to scan the inside of the atrium 3 by bending, as shown in broken line 28'. The location is monitored by external or internal sensors. A position of a tip of the steerable catheter 28 can also be monitored by fluoroscopy. The catheter tip contains a heating and/or ablation element 10. Steerable catheters 28 may advantageously carry a wide range of ablation systems, since only one connection and one point is needed.

A full mesh trades a higher complexity for better speed and accuracy when compared to linear arrays or single point scanning

The previous examples were of unipolar ablation, with the ablation current returning to ground via the patient's body. The disclosed system can also be used for bipolar ablation

as shown in FIG. 11. In unipolar ablation the same voltage is connected to both leads 13 and 13' of an element 10. In bipolar ablation the voltage is connected to lead 13 while the other end, 13', is grounded. It is important that the element 10 will be of sufficient resistance to cause most of the ablation current to flow through heart tissue 1. Electrodes 30 make contact with tissue 1 while the wire used in the element 10 is covered by an insulator. The advantage of bipolar ablation is better control of ablation depth. Typical ablation temperatures are 60-80 degrees C. At a higher temperature the tissue 1 becomes less conductive, forcing the ablation current to seek a new path. This promotes full ablation of the tissue 1. The element 10 can also be designed to assist ablation by creating heat when ablation voltage is applied across it.

One possible advantage of at least some of the presently disclosed embodiments over electrical potential mapping methods is that the presently disclosed embodiments do not require perfect contact between the mesh 7 and the tissue 1. The presently disclosed embodiments may also advantageously be less sensitive to the surface properties of the tissue, such as scar tissue or plaque.

If the mesh is separated from the tissue by a thin layer of blood, both the temperature sensing and the ablation functions of the presently disclosed embodiments will still function properly.

The word "element" in this disclosure has to be interpreted in a broad sense as any element capable of sensing blood flow. Clearly the elements do not need to be heaters, as cooling elements will work equally well. If a material is injected into the blood flow, any sensor capable of detecting this material can be used to detect blood flow. By the way of example, if the blood is cooled or warmed slightly before returning to the heart only temperatures sensors are needed. Since temperature differences as low as 0.1 degree C. can be detected reliably, it is fairly simple to heat or cool the blood slightly before it returns to the heart (even by a simple external pad).

The above description of illustrated embodiments, including what is described in the Abstract, is not intended to be exhaustive or to limit the embodiments to the precise forms disclosed. Although specific embodiments of and examples are described herein for illustrative purposes, various equivalent modifications can be made without departing from the spirit and scope of the disclosure, as will be recognized by those skilled in the relevant art.

The various embodiments described above can be combined to provide further embodiments. All of the U.S. patents, U.S. patent application publications, U.S. patent applications, foreign patents, foreign patent applications and non-patent publications referred to in this specification and/or listed in the Application Data Sheet are incorporated herein by reference, in their entirety. Aspects of the embodiments can be modified, if necessary, to employ systems, circuits and concepts of the various patents, applications and publications to provide yet further embodiments.

These and other changes can be made to the embodiments in light of the above-detailed description. In general, in the following claims, the terms used should not be construed to limit the claims to the specific embodiments disclosed in the specification and the claims, but should be construed to include all possible embodiments along with the full scope of equivalents to which such claims are entitled. Accordingly, the claims are not limited by the disclosure.

What is claimed is:

1. A medical system comprising:
 - a display console; and

a control computer connected to the display console, the control computer configured to:

acquire information from each element of at least a group of elements of a plurality of elements positionable in an intra-cardiac cavity and connected to the control computer;

cause the display console to display a map including a graphical depiction of an opening in the intra-cardiac cavity based at least on the information acquired from each element of the at least the group of elements in a state in which the group of elements is positioned in the intra-cardiac cavity;

receive user-input indicating user-selected ablation elements of some, but not all, of a plurality of ablation elements to define a user-selected tissue ablation pattern, the plurality of ablation elements arrangeable in a spatial distribution during a state in which the plurality of ablation elements is deployed in the intra-cardiac cavity, and each ablation element of the plurality of ablation elements selectively operable to cause tissue ablation; and

cause, prior to beginning ablation of the user-selected tissue ablation pattern, the display console to display, within the map, a graphical representation of the user-selected tissue ablation pattern at least in response to the user-input,

wherein the graphical representation of the user-selected tissue ablation pattern that is displayed within the map at least in response to the user-input visually indicates a plurality of first graphical elements, and

wherein the map visually indicates a plurality of second graphical elements, the plurality of first graphical elements respectively corresponding to the user-selected ablation elements, at least some of the plurality of first graphical elements surrounding the graphical depiction of the opening in the intra-cardiac cavity within the map, the plurality of second graphical elements respectively corresponding to non-user-selected ablation elements, the plurality of second graphical elements graphically depicted differently within the map than the plurality of first graphical elements, and the plurality of first graphical elements and the plurality of second graphical elements collectively spatially arranged within the map in correspondence with the spatial distribution.

2. The medical system of claim 1, wherein the map visually indicates the plurality of first graphical elements and the plurality of second graphical elements in an arrangement comprising a plurality of rows and a plurality of columns, wherein each row of (a) at least two of the rows, each column of (b) at least two of the columns, or each row and column of both (a) and (b) respectively comprises graphical depictions of at least one graphical element of the plurality of first graphical elements and at least one graphical element of the plurality of second graphical elements.

3. The medical system of claim 1, wherein the map visually indicates the plurality of first graphical elements and the plurality of second graphical elements in an arrangement comprising a plurality of rows and a plurality of columns, wherein each row of (a) at least two of the rows, each column of (b) at least two of the columns, or each row and column of both (a) and (b) respectively comprises graphical depictions of at least two graphical elements of the plurality of first graphical elements.

4. The medical system of claim 1, wherein at least some of the plurality of first graphical elements, which are visually indicated by the graphical representation of the user-selected

tissue ablation pattern that is displayed within the map at least in response to the user-input, surround at least some of the plurality of second graphical elements corresponding to the non-user-selected ablation elements.

5. The medical system of claim 1, wherein the graphical representation of the user-selected tissue ablation pattern that is displayed within the map at least in response to the user-input represents the user-selected tissue ablation pattern along multiple axes.

6. The medical system of claim 5, wherein the graphical representation represents the user-selected tissue ablation pattern as comprising a plurality of elongated segments, and wherein at least two of the elongated segments are collinear with different ones of the multiple axes.

7. The medical system of claim 5, wherein the plurality of first graphical elements are elongated segments, and wherein at least two of the elongated segments are collinear with different ones of the multiple axes.

8. The medical system of claim 1, wherein the control computer is further configured to cause the display console to display a grid comprising a plurality of rows and a plurality of columns, wherein the graphical representation of the user-selected tissue ablation pattern that is displayed within the map at least in response to the user-input occurs in alignment with the rows and columns of the grid.

9. The medical system of claim 1, wherein each graphical element of the plurality of first graphical elements and each graphical element of the plurality of second graphical elements is an elongated segment.

10. The medical system of claim 1, wherein the map includes a graphical region corresponding to a surface of a wall of the intra-cardiac cavity, the graphical region interrupted by the graphical depiction of the opening in the intra-cardiac cavity,

wherein the map graphically depicts at least some of the plurality of first graphical elements entirely within the graphical region corresponding to the surface of the wall of the intra-cardiac cavity, and

wherein the map graphically depicts at least some of the plurality of second graphical elements as partially or entirely overlying the graphical depiction of the opening in the intra-cardiac cavity.

11. The medical system of claim 1, wherein the map includes a graphical region corresponding to a surface of a wall of the intra-cardiac cavity, the graphical region interrupted by the graphical depiction of the opening in the intra-cardiac cavity, wherein each of the user-selected ablation elements is configured to entirely overlie the surface of the wall of the intra-cardiac cavity at least in the state in which the plurality of ablation elements is deployed in the intra-cardiac cavity, and at least some of the non-user-selected ablation elements that are configured to partially or entirely overlie the opening in the intra-cardiac cavity at least in the state in which the plurality of ablation elements is deployed in the intra-cardiac cavity.

12. The medical system of claim 1, wherein the plurality of ablation elements is formed as a mesh.

13. The medical system of claim 1, wherein the plurality of ablation elements is configured to assume different positions including a position suitable for percutaneous delivery to the intra-cardiac cavity and an expanded position in which the plurality of ablation elements is deployed in the intra-cardiac cavity.

14. The medical system of claim 1, wherein the plurality of first graphical elements, which are visually indicated by the graphical representation of the user-selected tissue abla-

tion pattern that is displayed within the map at least in response to the user-input, are emphasized as compared to the plurality of second graphical elements, which respectively correspond to the non-user-selected ablation elements.

15. The medical system of claim 1, wherein each element of the plurality of elements is operable to ablate tissue using RF ablation, laser ablation, microwave ablation, or cryogenic ablation.

16. The medical system of claim 1, wherein each element of the plurality of elements is configured to sense blood flow.

17. The medical system of claim 16,

wherein the map includes a graphical region corresponding to a surface of a wall of the intra-cardiac cavity, the graphical region interrupted by the graphical depiction of the opening in the intra-cardiac cavity,

wherein the map graphically depicts at least some of the plurality of first graphical elements entirely within the graphical region corresponding to the surface of the wall of the intra-cardiac cavity, and

wherein the map graphically depicts at least some of the plurality of second graphical elements as overlying, at least in part, the graphical depiction of the opening in the intra-cardiac cavity.

18. The medical system of claim 16, wherein the control computer is configured to cause each element of the plurality of elements to be switchable between a mapping mode in which the information is acquired from each element of the plurality of elements switched to the mapping mode, and an ablation mode in which each element of the plurality of elements switched to the ablation mode is operable to ablate tissue.

19. The medical system of claim 16, wherein the information is indicative of blood flow in the intra-cardiac cavity.

20. The medical system of claim 1, wherein the plurality of ablation elements is connected to the control computer, and wherein the control computer is configured to operate the user-selected ablation elements of the plurality of ablation elements to cause ablation of the user-selected tissue ablation pattern in tissue of the intra-cardiac cavity.

21. The medical system of claim 1, wherein the plurality of ablation elements are arrangeable in a three-dimensional spatial distribution during the state in which the plurality of ablation elements is deployed in the intra-cardiac cavity, and wherein the plurality of first graphical elements and the plurality of second graphical elements collectively are spatially arranged in a two-dimensional spatial distribution that corresponds to, but is different than, the three-dimensional spatial distribution.

22. The medical system of claim 1, wherein the control computer is configured to:

control at least one of a plurality of elements to measure temperature within the intra-cardiac cavity; and
cause the display console to display the map and information related to the measured temperature.

23. The medical system of claim 1, wherein the graphical representation of the user-selected tissue ablation pattern that is displayed within the map at least in response to the user-input visually overlies a graphical region of the map corresponding to a tissue surface of the intra-cardiac cavity, the graphical region interrupted by the graphical depiction of the opening in the intra-cardiac cavity.

24. A medical system comprising:

a display console; and

a control computer connected to the display console, the control computer configured to:

acquire information from each element of at least a group of elements of a plurality of elements positionable in an intra-cardiac cavity and connected to the control computer;

cause the display console to display a map including a graphical depiction of an opening in the intra-cardiac cavity based at least on the information acquired from each element of the at least the group of elements in a state in which the group of elements is positioned in the intra-cardiac cavity, the map visually indicating a plurality of tissue-ablation-pattern graphical elements;

receive user-input indicating a user-selection of some, but not all, of the visually indicated tissue-ablation-pattern graphical elements as a tissue ablation pattern comprising a plurality of user-selected tissue-ablation-pattern graphical elements of the plurality of tissue-ablation-pattern graphical elements; and

cause the display console to display, within the map, a graphical representation of the tissue ablation pattern at least in response to the user-input in a manner that visually distinguishes the user-selected tissue-ablation-pattern graphical elements from others of the tissue-ablation-pattern graphical elements that are not user-selected as part of the tissue ablation pattern, at least some of the plurality of user-selected tissue-ablation-pattern graphical elements surrounding the graphical depiction of the opening in the intra-cardiac cavity within the map, and

wherein the graphical representation of the tissue ablation pattern that is displayed within the map at least in response to the user-input visually displays the plurality of user-selected tissue-ablation-pattern graphical elements as arranged in a spatial distribution consistent with the tissue ablation pattern.

25. The medical system of claim 24, further comprising a plurality of ablation elements connected to the control computer, each ablation element of the plurality of ablation elements selectively operable to cause tissue ablation, wherein the plurality of user-selected tissue-ablation-pattern graphical elements, which are visually indicated in the map, respectively represent some, but not all, of the plurality of ablation elements.

26. The medical system of claim 24, wherein the graphical representation of the tissue ablation pattern surrounds at least some of the tissue-ablation-pattern graphical elements of the plurality of tissue-ablation-pattern graphical elements that are not user-selected as part of the tissue ablation pattern.

27. The medical system of claim 24, wherein the graphical representation represents the tissue ablation pattern along multiple axes.

28. The medical system of claim 27, wherein the graphical representation represents the tissue ablation pattern as comprising a plurality of elongated segments, and wherein at least two of the elongated segments are collinear with different ones of the multiple axes.

29. The medical system of claim 24, wherein the control computer is further configured to cause the display console to display a grid comprising a plurality of rows and a plurality of columns, and wherein the display of the graphical representation of the tissue ablation pattern occurs in alignment with the rows and columns of the grid.

30. The medical system of claim 24, wherein the control computer is further configured to cause the display console to display each tissue-ablation-pattern graphical element of the visually indicated plurality of tissue-ablation-pattern graphical elements in an arrangement comprising a plurality

of rows and a plurality of columns, each row of the plurality of rows comprising at least two tissue-ablation-pattern graphical elements of the visually indicated plurality of tissue-ablation-pattern graphical elements, and each column of the plurality of columns comprising at least two tissue-ablation-pattern graphical elements of the visually indicated plurality of tissue-ablation-pattern graphical elements.

31. The medical system of claim 30, wherein the graphical representation represents the tissue ablation pattern along multiple axes, wherein each tissue-ablation-pattern graphical element of the visually indicated plurality of tissue-ablation-pattern graphical elements comprises an elongated segment, and wherein at least two of the elongated segments are collinear with different ones of the multiple axes.

32. The medical system of claim 24, wherein each tissue-ablation-pattern graphical element of the visually indicated plurality of tissue-ablation-pattern graphical elements comprises an elongated segment.

33. The medical system of claim 24, wherein the map includes a graphical region corresponding to a surface of a wall of the intra-cardiac cavity, the graphical region interrupted by the graphical depiction of the opening in the intra-cardiac cavity,

wherein the map graphically depicts at least some of the plurality of user-selected tissue-ablation-pattern graphical elements entirely within the graphical region corresponding to the surface of the wall of the intra-cardiac cavity, and

wherein the map graphically depicts at least some of the others of the tissue-ablation-pattern graphical elements, which are not user-selected as part of the tissue ablation pattern, as partially or entirely overlying the graphical depiction of the opening in the intra-cardiac cavity.

34. The medical system of claim 24, wherein the control computer is configured to cause each element of the plurality of elements to be switchable between a mapping mode in which the information is acquired from each element of the plurality of elements switched to the mapping mode, and an ablation mode in which each element of the plurality of elements switched to the ablation mode is operable to ablate tissue.

35. The medical system of claim 34, wherein each element of the plurality of elements is operable to ablate tissue using RF ablation, laser ablation, microwave ablation, or cryogenic ablation in the ablation mode.

36. The medical system of claim 24, wherein the plurality of elements is formed as a mesh.

37. The medical system of claim 24, wherein the plurality of elements is configured to assume different positions including a position suitable for percutaneous delivery to the intra-cardiac cavity and an expanded position in which the plurality of elements is deployed in the intra-cardiac cavity.

38. The medical system of claim 24, wherein the information is indicative of blood flow in the intra-cardiac cavity.

39. The medical system of claim 24, wherein each graphical element of the plurality of tissue-ablation-pattern graphical elements is selectable.

40. The medical system of claim 24, wherein the plurality of user-selected tissue-ablation-pattern graphical elements are spatially arranged in a two-dimensional spatial distribution that corresponds to, but is different than, a three-dimensional spatial distribution in which a plurality of user-selected ablation elements are arrangeable during a state in which the user-selected ablation elements are deployed in the intra-cardiac cavity, each graphical element of the plurality of user-selected tissue-ablation-pattern

graphical elements corresponding to a respective user-selected ablation element of the plurality of user-selected ablation elements.

41. The medical system of claim 24, wherein the control computer is configured to:

control at least one of a plurality of elements to measure temperature within an atrium; and
cause the display console to display the map and information related to the measured temperature.

42. The medical system of claim 24, wherein the graphical representation of the tissue ablation pattern that is displayed within the map at least in response to the user-input visually overlies a graphical region of the map corresponding to a tissue surface of the intra-cardiac cavity, the graphical region interrupted by the graphical depiction of the opening in the intra-cardiac cavity.

43. An ablation-pattern display method executed by a control computer, the method comprising:

acquiring information from each element of at least a group of elements of a plurality of elements positionable in an intra-cardiac cavity and connected to the control computer;

causing a display console connected to the control computer to display a map including a graphical depiction of an opening in the intra-cardiac cavity based at least on the information acquired from each element of the at least the group of elements in a state in which the group of elements is positioned in the intra-cardiac cavity;

receiving user-input indicating user-selected ablation elements of some, but not all, of a plurality of ablation elements to define a user-selected tissue ablation pattern, the plurality of ablation elements arrangeable in a spatial distribution during a state in which the plurality of ablation elements is deployed in the intra-cardiac cavity, and each ablation element of the plurality of ablation elements selectively operable to cause tissue ablation; and

causing, prior to beginning ablation of the user-selected tissue ablation pattern, the display console to display, within the map, a graphical representation of the user-selected tissue ablation pattern at least in response to the user-input,

wherein the graphical representation of the user-selected tissue ablation pattern that is displayed within the map at least in response to the user-input visually indicates a plurality of first graphical elements, and

wherein the map visually indicates a plurality of second graphical elements, the plurality of first graphical elements respectively corresponding to user-selected ablation elements, at least some of the plurality of first graphical elements surrounding the graphical depiction of the opening in the intra-cardiac cavity within the map, the plurality of second graphical elements respectively corresponding to non-user-selected ablation elements, the plurality of second graphical elements graphically depicted differently within the map than the plurality of first graphical elements, and the plurality of first graphical elements and the plurality of second graphical elements collectively spatially arranged within the map in correspondence with the spatial distribution.

44. The method of claim 43, wherein the plurality of ablation elements are arrangeable in a three-dimensional spatial distribution during the state in which the plurality of ablation elements is deployed in the intra-cardiac cavity, and wherein the plurality of first graphical elements and the

plurality of second graphical elements collectively are spatially arranged in a two-dimensional spatial distribution that corresponds to, but is different than, the three-dimensional spatial distribution.

45. The method of claim 43, wherein the map includes a graphical region corresponding to a surface of a wall of the intra-cardiac cavity, the graphical region interrupted by the graphical depiction of the opening in the intra-cardiac cavity, wherein the map graphically depicts at least some of the plurality of first graphical elements entirely within the graphical region corresponding to the surface of the wall of the intra-cardiac cavity depicted, and wherein the map graphically depicts at least some of the plurality of second graphical elements as partially or entirely overlying the graphical depiction of the opening in the intra-cardiac cavity.

46. The method of claim 43, comprising controlling at least one of a plurality of elements to measure temperature within the intra-cardiac cavity; and causing the display console to display the map and information related to the measured temperature.

47. The method of claim 43, wherein the graphical representation of the user-selected tissue ablation pattern that is displayed within the map at least in response to the user-input visually overlies a graphical region of the map corresponding to a tissue surface of the intra-cardiac cavity, the graphical region interrupted by the graphical depiction of the opening in the intra-cardiac cavity.

48. The method of claim 43, wherein the plurality of first graphical elements, which are visually indicated by the graphical representation of the user-selected tissue ablation pattern that is displayed within the map at least in response to the user-input, are emphasized as compared to the plurality of second graphical elements, which respectively correspond to the non-user-selected ablation elements.

49. An ablation-pattern display method executed by a control computer, the method comprising:
 acquiring information from each element of at least a group of elements of a plurality of elements positionable in an intra-cardiac cavity and connected to the control computer;
 causing a display console connected to the control computer to display a map including a graphical depiction of an opening in the intra-cardiac cavity based at least on the information acquired from each element of the at least the group of elements in a state in which the group of elements is positioned in the intra-cardiac cavity, the map visually indicating a plurality of tissue-ablation-pattern graphical elements;
 receiving user-input indicating a user-selection of some, but not all, of the visually indicated tissue-ablation-pattern graphical elements as a tissue ablation pattern comprising a plurality of user-selected tissue-ablation-pattern graphical elements of the plurality of tissue-ablation-pattern graphical elements; and
 causing the display console to display, within the map, a graphical representation of the tissue ablation pattern at

least in response to the user-input in a manner that visually distinguishes the user-selected tissue-ablation-pattern graphical elements from others of the tissue-ablation-pattern graphical elements that are not user-selected as part of the tissue ablation pattern, at least some of the plurality of user-selected tissue-ablation-pattern graphical elements surrounding the graphical depiction of the opening in the intra-cardiac cavity within the map, and

wherein the graphical representation of the tissue ablation pattern that is displayed within the map at least in response to the user-input visually displays the plurality of user-selected tissue-ablation-pattern graphical elements as arranged in a spatial distribution consistent with the tissue ablation pattern.

50. The method of claim 49, wherein the plurality of user-selected tissue-ablation-pattern graphical elements are spatially arranged in a two-dimensional spatial distribution that corresponds to, but is different than, a three-dimensional spatial distribution in which a plurality of user-selected ablation elements are arrangeable during a state in which the user-selected ablation elements are deployed in the intra-cardiac cavity, each graphical element of the plurality of user-selected tissue-ablation-pattern graphical elements corresponding to a respective user-selected ablation element of the plurality of user-selected ablation elements.

51. The method of claim 49, wherein the map includes a graphical region corresponding to a surface of a wall of the intra-cardiac cavity, the graphical region interrupted by the graphical depiction of the opening in the intra-cardiac cavity,

wherein the map graphically depicts at least some of the plurality of user-selected tissue-ablation-pattern graphical elements entirely within the graphical region corresponding to the surface of the wall of the intra-cardiac cavity, and

wherein the map graphically depicts at least some of the others of the tissue-ablation-pattern graphical elements, which are not user-selected as part of the tissue ablation pattern, as partially or entirely overlying the graphical depiction of the opening in the intra-cardiac cavity.

52. The method of claim 49, comprising:
 controlling at least one of a plurality of elements to measure temperature within an atrium; and
 causing the display console to display the map and information related to the measured temperature.

53. The method of claim 49, wherein the graphical representation of the tissue ablation pattern that is displayed within the map at least in response to the user-input visually overlies a graphical region of the map corresponding to a tissue surface of the intra-cardiac cavity, the graphical region interrupted by the graphical depiction of the opening in the intra-cardiac cavity.

54. The method of claim 49, wherein the plurality of user-selected tissue-ablation-pattern graphical elements are emphasized as compared to the others of the tissue-ablation-pattern graphical elements that are not user-selected as part of the tissue ablation pattern.

* * * * *

专利名称(译)	用于心脏内映射和消融的装置和方法		
公开(公告)号	US10028783	公开(公告)日	2018-07-24
申请号	US13/785910	申请日	2013-03-05
[标]申请(专利权)人(译)	卡尔蒂姆公司		
当前申请(专利权)人(译)	KARDIUM INC.		
[标]发明人	GELBART DANIEL LICHTENSTEIN SAMUEL VICTOR		
发明人	GELBART, DANIEL LICHTENSTEIN, SAMUEL VICTOR		
IPC分类号	A61B18/12 A61B18/14 A61B5/028 A61B18/10 A61B18/08 A61B5/00 A61B18/18 A61B18/02 A61B18/00 A61B18/20		
CPC分类号	A61B18/1492 A61B5/6858 A61B18/082 A61B18/10 A61B5/028 A61B2562/046 A61B5/6853 A61B18/18 A61B18/20 A61B2018/0016 A61B2018/0022 A61B2018/00267 A61B2018/00357 A61B2018/00577 A61B2018/00642 A61B2018/00714 A61B2018/00791 A61B2018/0212 A61B2018/0237 A61B2018/124 A61B2018/1407 A61B2562/0271		
其他公开文献	US20130184705A1		
外部链接	Espacenet		

摘要(译)

心内标测系统基于定位血液流入或流出心腔的端口。对于许多手术，例如消融治疗心房颤动，准确定位肺静脉和二尖瓣允许执行迷宫手术。端口和阀门的位置基于使用血流的对流冷却效果。可以通过导管部署的可扩展网或扫描导管来执行映射。相同的网或导管也可以执行消融手术。

